

553-3001-100

SL-1

System options 21, 51, 61, 71

System overview

Standard

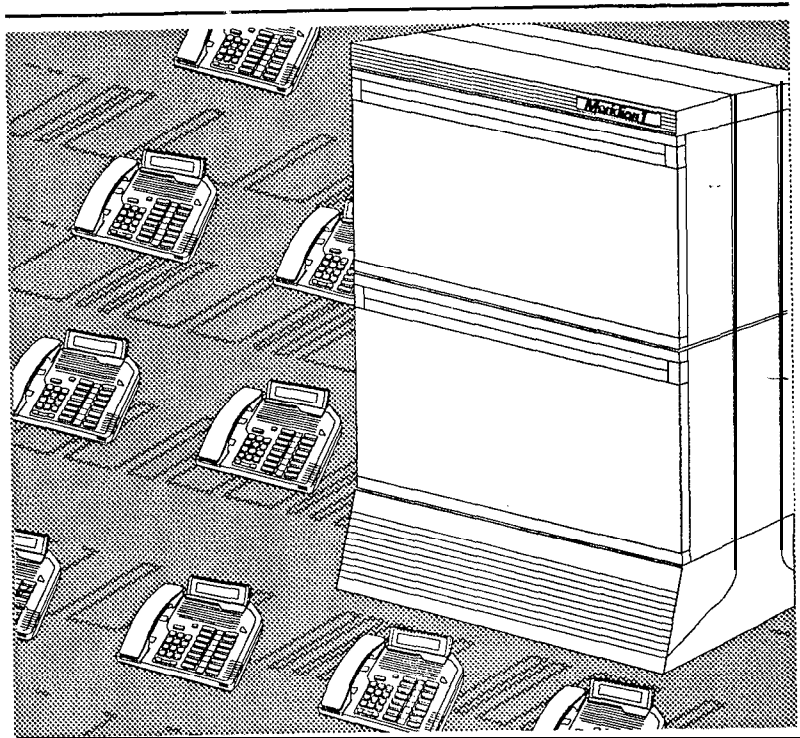

nt northern
telecom

Meridian I
Communication Systems





SL-1

System options 21, 51, 61, 71

System overview

Publication number: 553-3001 -I 00
Document release: 2.0
Document status: Standard
Date: February 28, 1990



© 1990 Northern Telecom

All right reserved

System overview 553-3001-I 00

Revision history

January 29, 1990

Standard, release 1.0

February 28, 1990

Standard, release 2.0

Contents

About this document	1
References	1
<hr/>	
Meridian 1 SL-1 Systems	3
Chapter contents	3
The Meridian 1 commitment	4
Product compatibility	5
System reliability	5
Modular equipment packaging	5
Advanced administration and maintenance	6
Ease of installation	6
Ease of expansion and upgrade	7
Advanced features	7
Automatic Call Distribution	7
Electronic Switched Network	8
Call Detail Recording	8
Integrated Services Digital Network	8
Meridian Mail	8
<hr/>	
System architecture	9
Chapter contents	9
Hardware architecture	10
Power Equipment	10
Common Equipment	12
Network Equipment	15
Peripheral Equipment	23
Software architecture	25
Resident programs	25
Non-resident programs	25

Product description	27
Chapter contents	27
Meridian 1 SL-1 Systems	28
System option 21A	28
System option 21	30
System option 51	32
System option 61	34
System option 71	36
Column hardware	38
Modules	39
Pedestal	49
Top Cap	49
Spacer Kit	50
<hr/>	
List of terms	51

About this document

This document describes the features and services, hardware and software architecture, and the family of products that comprise Meridian 1 SL-1 Systems.

References

See the *SL-1 planning & engineering guide* for

- **Master index** (553-3001-000)
- **System overview** (553-3001-100)
- **Installation planning** (553-3001-120)
- **System engineering** (553-3001-151)
- **Power engineering** (553-3001-152)
- Spares planning (553-3001-153)
- **Equipment identification and ordering** (553-3001-154)

See the list of line and trunk circuit descriptions in the **Master index** (553-3001-000) for specific references to lines and trunks.

See the *SL-1 installation and maintenance guide* for

- **System installation procedures** (553-3001-210)
- **Circuit pack installation and testing** (553-3001-211)
- **Installation procedures for telephone sets and attendant consoles** (553-3001-215)
- **Extended systems installation** (553-3001-250)

- **Disk drive upgrade** *procedures* (553-3001-251)
- **General maintenance information** (553-3001-500)
- **Fault clearing**(553-3001-510)
- **Hardware replacement** (553-3001-520)

See the **SL-I X11 software guide** for an overview of software architecture, procedures for software installation and management, and a detailed description of all X 11 features and services. This information is contained in two documents:

- **X11 software management** (553-3001-300)
- **X11 features and services** (553-3001-305)

See the **SL-I XII input/output guide** (553-300140) for a description of all administration programs, maintenance programs, and system messages...

Meridian 1 SL-1 Systems

Chapter contents

The Meridian 1 commitment	4
Product compatibility	5
System reliability	5
Modular equipment packaging	5
Advanced administration and maintenance	6
Ease of installation	6
Ease of expansion and upgrade	7
Advanced features	7
Automatic Call Distribution	7
Electronic Switched Network	8
Call Detail Recording	8
Integrated Services Digital Network	8
Meridian Mail	8

Introduction

Meridian 1 Communication Systems are a family of digital multiplex voice and data switching systems built on a foundation of state of the art digital switching equipment and advanced software program control. Meridian 1 systems provide a wide range of sophisticated voice and data services for both Private Branch Exchange (**PBX**) and Central Office (CO) applications ranging in size from 30 to 60,000 ports.

Meridian 1 Communication Systems provide solutions to the complex requirements of today's business communications environment. In a single, integrated system, it provides advanced voice features, local area network communications, and **sophisticated** information services. A comprehensive open architecture ensures continual growth in capacity and the capability to address the ongoing needs of business communications and information management.

The foundation for Meridian 1 SL-1 Systems is a voice and data **circuit-**switched digital system. It is comprised of a central processing unit, memory store, and a digital switching network that uses Time Division Multiplexing and Pulse Code Modulation techniques. Peripheral interfaces are used to connect a wide array of telephones, trunks, and terminals.

Meridian 1 Sk-1 Systems are also designed to accommodate the rapidly expanding requirements for data communications. Building on the strength of SL-1 architecture, significant system enhancements have been developed for data communications.

The Meridian 1 commitment

Northern Telecom is committed to meeting the needs of our customers by providing systems which guarantee:

- continuing product compatibility
- a high degree of component and system reliability
- cost effective, modular packaging
- advanced administration and maintenance capabilities
- ease of installation
- ease of expansion and upgrade

Product compatibility

All new SL-1 products are compatible with the installed base of systems and can be installed alongside existing equipment. Peripheral Equipment, which is the bulk of the system investment, is common to all SL-1 system options and may be retained when systems are upgraded or expanded.

In addition, Meridian 1 SL-1 Systems now use the DS-30 signaling method used by other Northern Telecom switching products. A common signaling scheme throughout the Meridian 1 family allows for system growth beyond 10,000 ports without requiring a change in Peripheral Equipment.

System reliability

Meridian 1 SL-1 Systems are designed and built to meet the highest standards for reliability, resulting in less downtime and increased system availability.

In many systems, the Central Processing Unit (CPU) and memory are duplicated to guarantee system reliability. In these dual CPU systems, both CPUs can access redundant memory stores. If one CPU or Memory Card fails, the system automatically switches to the standby CPU or memory without disrupting call processing.

Modular equipment packaging

Flexible system packaging is provided through a highly modular packaging scheme. Modular packaging provides low cost, easy expansion from one system option to another.

The basic unit of the modular package is the Universal Equipment Module (UEM): a modular, self-contained hardware cabinet that houses a card cage, power supply, backplane, circuit cards, and other basic equipment. When the UEM is equipped, it supports a system function and becomes a specific type of module, such as a CPU Module or Network Module.

In addition, the UEM provides universal support for a wide variety of card cages which integrate specific applications and features, such as Meridian Mail, into the system.

Advanced administration and maintenance

Advanced administration and maintenance capabilities are common to all SL-1 Systems. Administration and maintenance functions include assigning features, adding or deleting equipment, and monitoring and testing equipment. These functions can be performed locally or from a remote location.

The System Monitor circuit card in the Meridian 1 SL-1 System provides advanced power monitoring. The System Monitor initiates system messages regarding the status and functions of cooling equipment and power-related hardware. These system messages include status or fault indications, hardware type, column number, module number, and, when applicable, the power supply unit number.

Intelligent Peripheral Equipment circuit cards contain microprocessors which off-load processing functions, previously performed by the CPU, and significantly increase diagnostic capabilities. On-board intelligence allows cards to report their product code, serial number, release number, and manufacture location, which assists in maintenance and inventory control. On-board microprocessors also allow circuit card parameter changes without hardware revisions.

Meridian Manager consists of a number of personal computer application programs designed to simplify administration and monitoring. There are three Meridian Manager option packages:

- Station Administration software converts station-related mnemonics (in LD 10 and LD 11) into a database that is easily administered and maintained on the personal computer.
- Traffic Reporting provides clear, easy-to-understand reports on trunk, attendant, network loop, and CPU use.
- Work Order System automates move, add, and change functions for administrative functions (such as change management, inventory management, cost allocation, and purchasing support).

Ease of installation

Meridian 1 SL-1 Systems are shipped from the factory assembled and equipped to order. Installation effort is reduced to unpacking and positioning equipment, plugging in connector&d cables, and adding customer-specific programming where required.

Ease of expansion and upgrade

Modular packaging accommodates growth by permitting easy expansion. Increasing system size simply requires adding one or more modules to existing equipment.

Network enhanced Meridian SL- 1 systems can be upgraded to Meridian 1 by adding XI 1 Release 15 software with compatible data and memory storage, a Superloop Network Card, and an Intelligent Peripheral Equipment Module. Systems which have not been network enhanced can be upgraded to the enhanced level, then to Meridian 1.

SL-1 systems also provide an automatic in-line conversion feature which significantly simplifies upgrading software. For more information about upgrading existing systems, see ***Upgraded systems installation*** (553-3001-250).

Advanced features

By providing software-defined service capabilities, Meridian 1 SL-1 Systems offer advanced features and capabilities in an economical, flexible, and maintainable form. In addition to a wide range of standard voice and data services, SL-1 Systems provide a number of sophisticated communications services and features, including:

- Automatic Call Distribution
- Electronic Switched Network
- Call Detail Recording
- Integrated Services Digital Network
- Meridian Mail

Automatic Call Distribution

Automatic Call Distribution (ACD) is used when a large number of incoming calls need to be distributed among a designated group of telephone sets. For more information on ACD, refer to Northern Telecom Publication ***Automatic Call Distribution Basic features description*** (553-2671-100).

Electronic Switched Network

The Electronic Switched Network (ESN) group of features supports voice and circuit-switched voiceband data telecommunications for multiple-location customer applications. ESN applications range from a single network node to a widely-dispersed network with up to 256 locations. For more information on ESN, refer to the **ESN Feature Document (64004386)** and to the following Northern Telecom Publications:

- **Electronic Switched Network: General Description** (308-3001-100)
- **Basic and Network Alternate Route Selection: General Description** (553-2751-100)
- **Coordinated Dialing Plan: General Description** (553-2751-102)

Call Detail Recording

Call Detail Recording (CDR) gathers call processing data and produces call records used for accounting and administrative purposes. Call records include the time and date the call was placed, the identity of the caller, and the digits dialed. For more information on CDR, see **Call Detail Recording: General Description** (553-2631-100).

Integrated Services Digital Network

Integrated Services Digital Network (ISDN) is an international specification -- of standards for digital communications. ISDN provides standard digital interfaces between telephones, terminals, and telecommunication networks. ISDN services are distinguished by two types of access: Primary Rate Access (PRA) and Basic Rate Access (BRA). For more information on PRA, see **ISDN Primary Rate Access: Product Description** (553-2901-100).

Meridian Mail

Meridian Mail is a comprehensive electronic voice processing system. Meridian Mail provides a wide array of sophisticated features, including telephone call answering, voice messaging, automated attendant service, call routing, information mailbox, and interactive voice response applications. Guided by easy to follow prompts, a user can leave messages for others, retrieve messages, forward messages, and respond to messages with the touch of a single button. For more information on Meridian Mail, see **Meridian Mail: General Description** (553-7001-100).

System architecture

Chapter contents

Hardware architecture	10
Power Equipment	10
Common Equipment	12
Network Equipment	15
Peripheral Equipment	23
Software architecture	25
Resident programs	25
Non-resident programs	25

Hardware architecture

Each SL-1 System includes the following internal hardware subsystems:

- Power Equipment provides the electrical voltages required for the system to operate.
- Common Equipment provides the device control, software execution, and memory functions of the system.
- Network Equipment performs the switching function under CPU control.
- Peripheral Equipment provides the interface for lines and trunks.

Power Equipment

Meridian 1 SL-1 Systems use a modular power distribution architecture which parallels the modular design of the Universal Equipment Module. The power system provides:

- AC-powered and DC-powered system options
- a System Monitor with enhanced monitoring capabilities
- a quick-connect wiring harness to power supplies in each module
- an advanced cooling system which uses forced-air impellers (in the NT8D52 Blower Unit)
- circuit breakers only (no fuses) within the column
- modular backup capabilities

AC- and DC-powered systems differ primarily in the power components outside of the UEM. Figures 1 and 2 are block diagrams of AC and DC powering schemes with reserve power supplies.

AC-powered systems are well suited to applications that do not require reserve power because the basic system does not require external power components (such as rectifiers). If reserve power is required for an AC system, an Uninterruptible Power Supply (UPS), available from a variety of vendors, can be used.

DC-powered systems require external power components (rectifiers). DC systems are well suited to applications that require reserve power because backup batteries can be connected to the rectifiers.

Figure 1
AC power architecture with reserve power

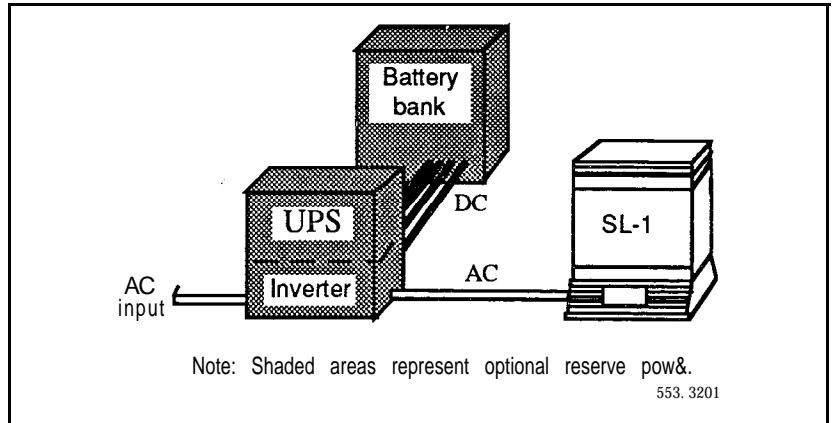
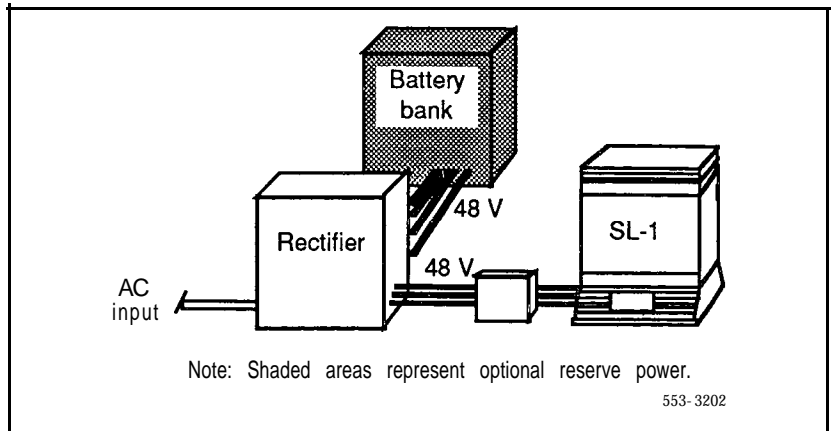

Figure 2
DC power architecture with reserve power



Common Equipment

Common Equipment (CE) is the control complex of the system. Common Equipment provides the sequences to process voice and data connections, monitor call activity, and perform system administration and maintenance.

Common Equipment communicates over a common control bus which carries a constant flow of program instructions and data under direct control of the (CPU). Common Equipment consists of

- the CPU, which provides the computing power essential for system operation
- system memory, which stores all operating software programs and data unique to each SL-1 System
- the mass storage unit, which supplies operating programs and data
- input/output interfaces, which provide an information exchange between the user and the CPU

Central Processing Unit

At system power-up, instructions stored in Read Only Memory (ROM) on the CPU daughterboard bring the system into a working state. The ROM then transfers data from the mass storage unit into the Random Access Memory (RAM) stored on Memory circuit cards.

During system operation, the CPU circuit cards access ROM and RAM data to perform control and switching sequences required by the system. The CPU also accesses and executes the fault clearing programs contained in ROM.

CPU design includes:

- 24-bit data words plus 1-bit parity
- 24-bit linear addressing that permits memory allocation to be assigned on a contiguous basis
- asynchronous (handshake) bus operation
- 16 tile registers, used to hold address and data for all operations

- a sense (interrupt) input line **to indicate** that a particular device requires action by the CPU
- a trap facility which, when activated by an external signal, causes the CPU to immediately execute instructions starting at a particular address

System memory

System memory stores all operating software programs and data unique to each SL-1 System. Solid-state memory consists of the:

- Read Only Memory (ROM)
- Random Access Memory (RAM)

Read Only Memory instructions are permanently programmed as firmware and housed on the CPU daughterboard. This memory stores basic operating programs, arithmetic functions, and the basic rules of operation necessary to initialize the system and bring it into a working state. The ROM also stores the recovery, or “trap,” sequence which is automatically invoked in response to power-up, system reload, or when certain faults are detected.

Random Access Memory is volatile memory stored on the Memory circuit cards. There are three functional areas of RAM:

- Unprotected Data Store (called UDATA) --
holds constantly changing, unprotected data required during call processing (such as call registers, call connection, and traffic data)
- Protected Data Store (called PDATA or Office Data)
stores protected customer specific information (such as trunk configuration, telephone set configuration, and speed call data)
- Program Store
stores call processing programs, programs required for communication with ROM, and programmed features and options (such as conference and call transfer)

Input/output interfaces

External input/output (I/O) devices (terminals, printers, and personal computers, for example) are used to input commands to the CPU during administration and maintenance procedures, and to receive information output by the CPU. Up to 16 I/O devices are allowed. They may be located at local or remote sites.

The I/O devices exchange information with the CPU through Serial Data Interface (SDI) circuit cards. The **SDI** cards conform to EIA Data Interchange Standard RS-232-C; I/O devices must be RS-232-C compatible.

Mass storage unit

At system power-up or during a sysload (system reload), Protected Data Store (Office Data) and Program Store information is automatically transferred from the mass storage unit to the Memory circuit cards. During regular operation, the CPU accesses information from the Memory cards.

If information in Protected Data Store is changed (if, for example, you change a telephone set configuration), the information on the mass storage unit must be updated. Transferring data from Memory cards to the mass storage unit is called a **data dump**. Data dumps can occur automatically and manually (using LD 43).

There are two mass storage units available:

- The **NT8D68 Floppy Disk Unit (FDU)** has two 3.5 inch 1.44 Mbyte disk drives (providing 2.4 Mbytes of formatted capacity).
- The **NT8D69 Multi Disk Unit (MDU)** has a Winchester hard disk with a minimum of 20 Mbytes of formatted capacity and two 3.5 inch 1.44 Mbyte disk drives (used for backup and system loading in this unit).

Network Equipment

Network Equipment performs the system switching function which interconnects peripheral ports for communication with each other. Network architecture is based on the digital multiplexed loop. A loop transmits voice, data, and signaling information over a bidirectional path between the network and peripheral ports.

Network equipment consists of network circuit cards which digitally transmit voice and data signals, and service circuit cards (the Conference/Tone and Digit Switch Card, for example) which provide call progress tones and outpulsing. Network cards use Space Switching and Time Division Multiplexing (TDM) technology to perform the switching function.

Meridian 1 SL-1 Systems provide:

- the NT8D04 Superloop Network Card, which provides four loops per card, grouped together in an entity called a superloop
- the QPC414 Network Card, which provides two loops per card

Network organization

On most SL- 1 system options, network loops are organized into groups. Systems are generally configured as half, full, or multiple group machines. A half network group provides up to 16 loops, a full group system provides up to 32 loops, and a multiple group system provides up to 160 loops.

An additional switching stage is required in a multi-group configuration. This switching stage, an extension of the originating and terminating network loop, is provided by the InterGroup Switch Card and the InterGroup Module. There are eight one-way junctions from each group to all others. Since each path provides 30 connecting channels, there are a total of 480 connection paths (240 connection paths in each direction). Five network groups may be interconnected to form a fully configured digital switching matrix.

Superloop network configurations

By combining four regular network loops, the Superloop Network Card makes 120 timeslots available to Intelligent Peripheral Equipment (IPE). This increased bandwidth and larger pool of timeslots increases network traffic capacity for each 120 timeslot bundle by 25 percent (at a PO.1 grade of service).

The NT8D37 IPE Module is divided into segments of four card slots numbered 0-3 (see Figure 3). Segment 0 consists of slots 0-3, Segment 1 consists of slots 4-7, Segment 2 consists of slots 8-11, and Segment 3 consists of slots 12-15.

Figure 3
Superloop segments in the Intelligent Peripheral Module

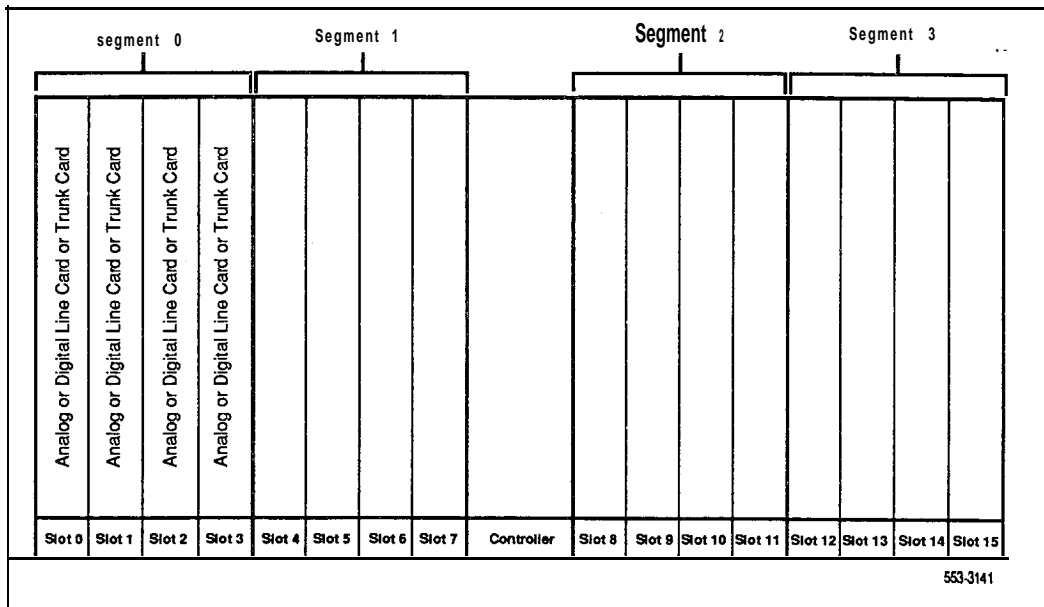

A superloop may be assigned from one to eight IPE segments. A number of superloop-to-segment configurations are possible.

One segment can be assigned to one superloop (see Figure 4). This configuration requires four Superloop Network Cards and one Controller Card-4.

If the segment is equipped with intelligent Digital Line Cards with all 16 voice and all 16 data TNS provisioned, this configuration provides a virtual non-blocking environment (120 timeslots to 128 TNS).

Figure 4
One segment per superloop configuration

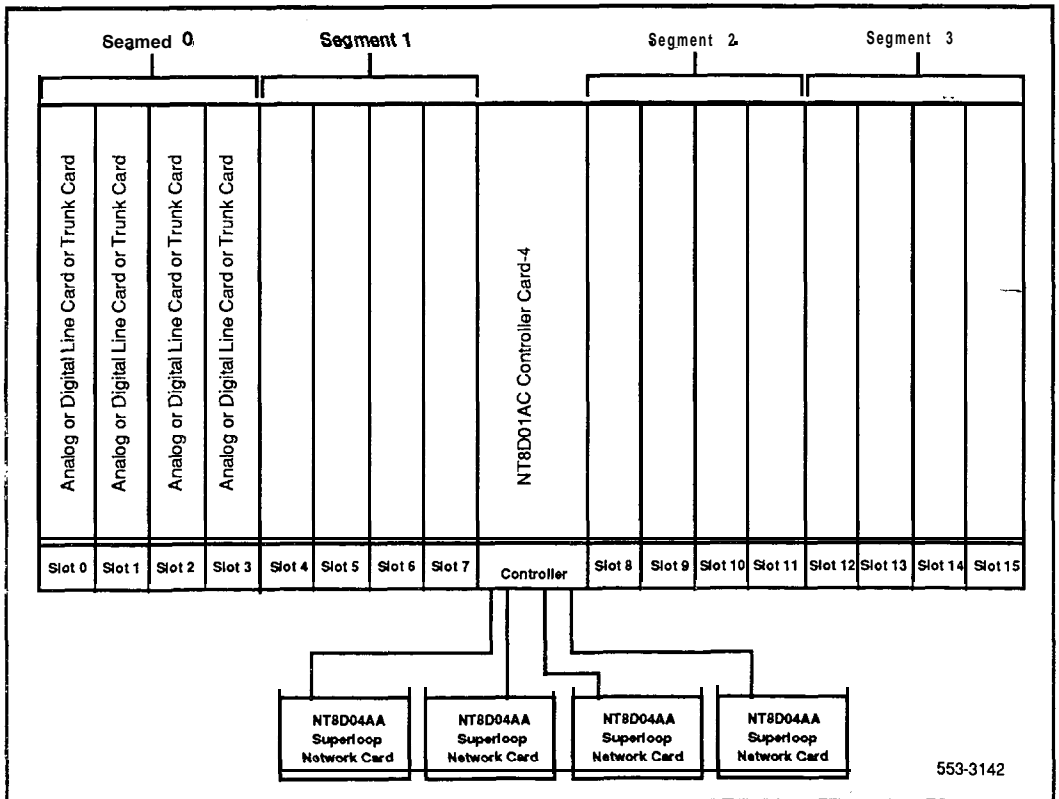

Two segments can be assigned to one superloop (see Figure 5). This configuration requires two Superloop Network Cards and one Controller Card-2.

If the segment is equipped with intelligent line and **trunk** cards without data **TNs** enabled, this configuration provides a virtual non-blocking environment (120 timeslots to 32-128 **TNs**).

If half the data **TNs** on Digital Line Cards are enabled, this configuration still provides a low concentration of **TNs** to timeslots (120 timeslots to 196 **TNs**) and a very low probability of blocking.

Figure 5
Two segments per superloop configuration

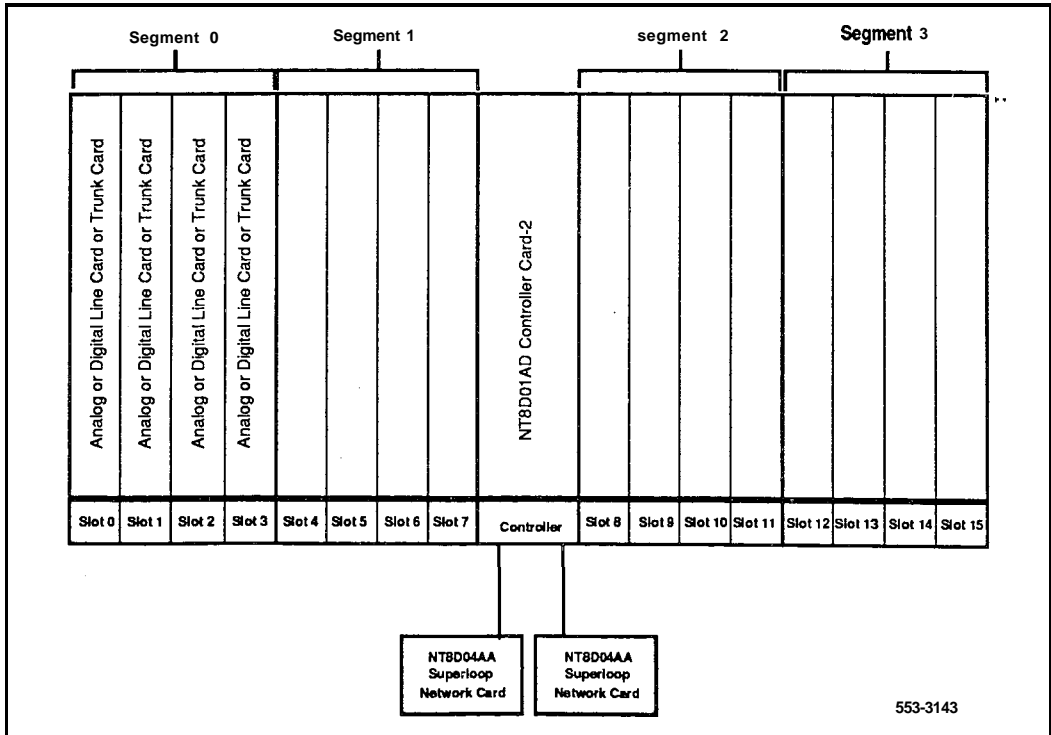

Four segments can be assigned to one superloop (see Figure 6). One Superloop Network Card and one Controller Card-2 are used to implement this configuration.

If the segment is equipped with intelligent line and trunk cards, this configuration provides a medium concentration environment (120 timeslots to 64-256 TNs).

If half the data TNs on Digital Line Cards are enabled, this configuration provides a concentration of 120 timeslots to 384 TNs.

Figure 6
Four segments per superloop configuration

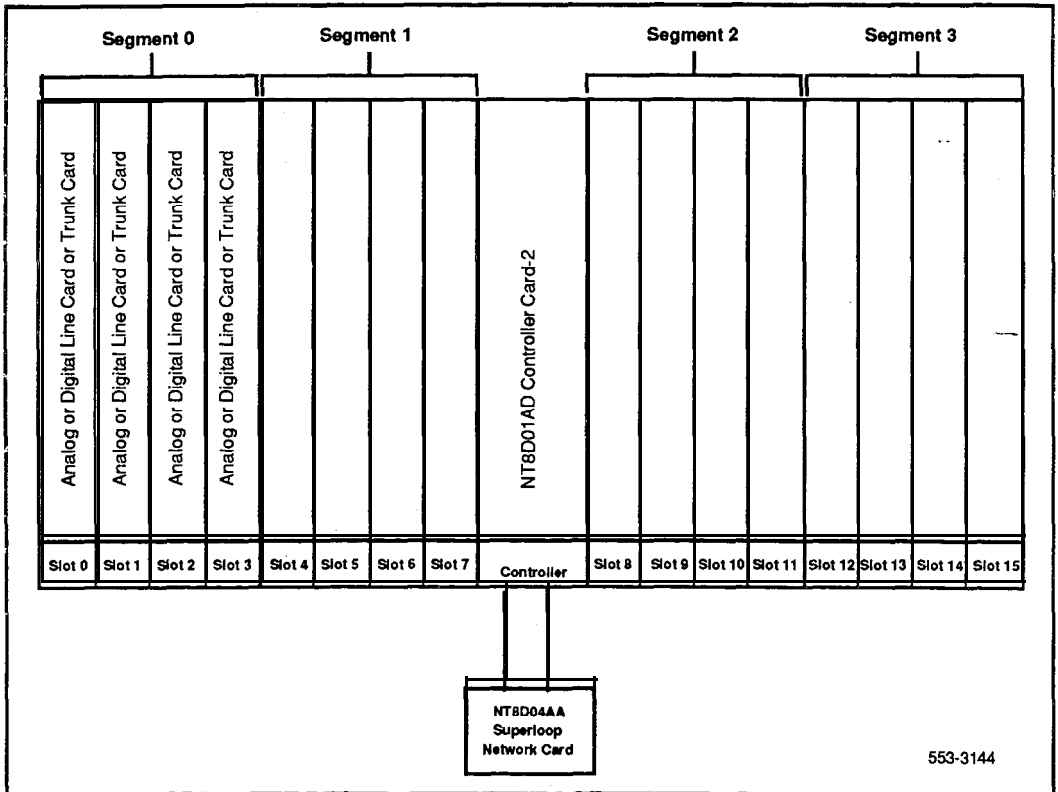

Eight segments can be **assigned** to one superloop (see Figure 7). This configuration requires one Superloop Network Card and two Controller Card-2 units.

If the segment is equipped with intelligent line and trunk cards, this configuration provides a high concentration environment (120 timeslots to 128-5 12 TNs).

If half **the** data **TNs** on Digital Line Cards are enabled, this configuration provides a concentration of 120 timeslots to 768 **TNs**.

Figure 7
Eight segments per superloop configuration

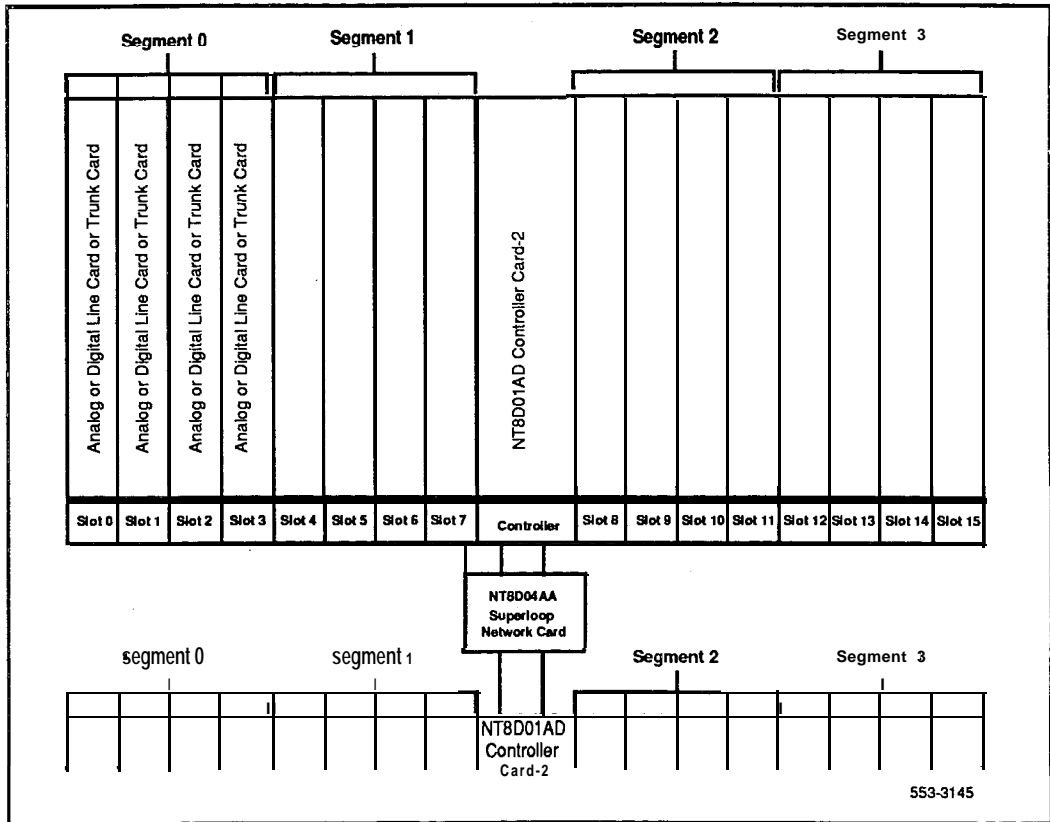

One segment can be assigned to one superloop and an additional three segments to another superloop (see Figure 8). This configuration requires two Superloop Network Cards and one Controller Card-2.

This configuration provides:

- a virtual non-blocking environment (120 timeslots to 128 TNs) for the single segment served by the first superloop
- a medium concentration of TNs to timeslots for the three segments assigned to the additional superloop

Figure 8
One segment per superloop/three segments per superloop configuration

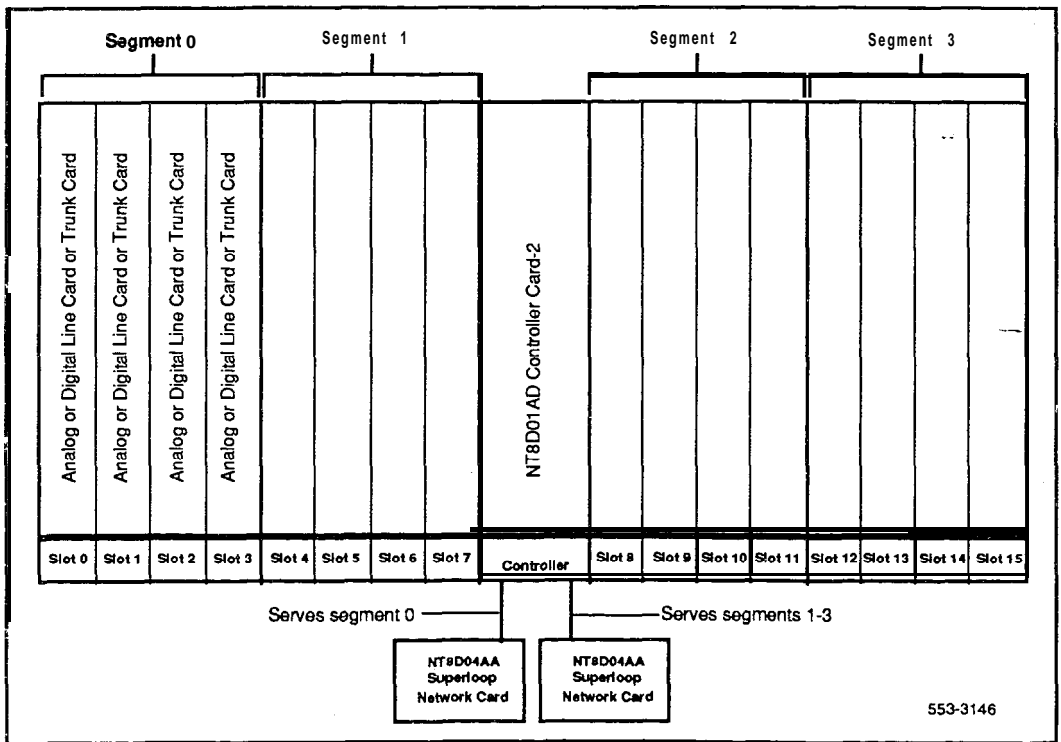

Two segments can be assigned to one superloop and an additional six segments to another superloop (see Figure 9). This configuration requires two Superloop Network Cards and two Controller Card-2 units.

This configuration provides:

- a virtual non-blocking environment for the **two** segments served by the **first** superloop (or a very low concentration of **TNs** to timeslots if some data **TNs** are enabled)
- a medium concentration of **TNs** to timeslots for the six segments assigned to the additional superloop

Figure 9
Two segments per superloop six segments per superloop configuration

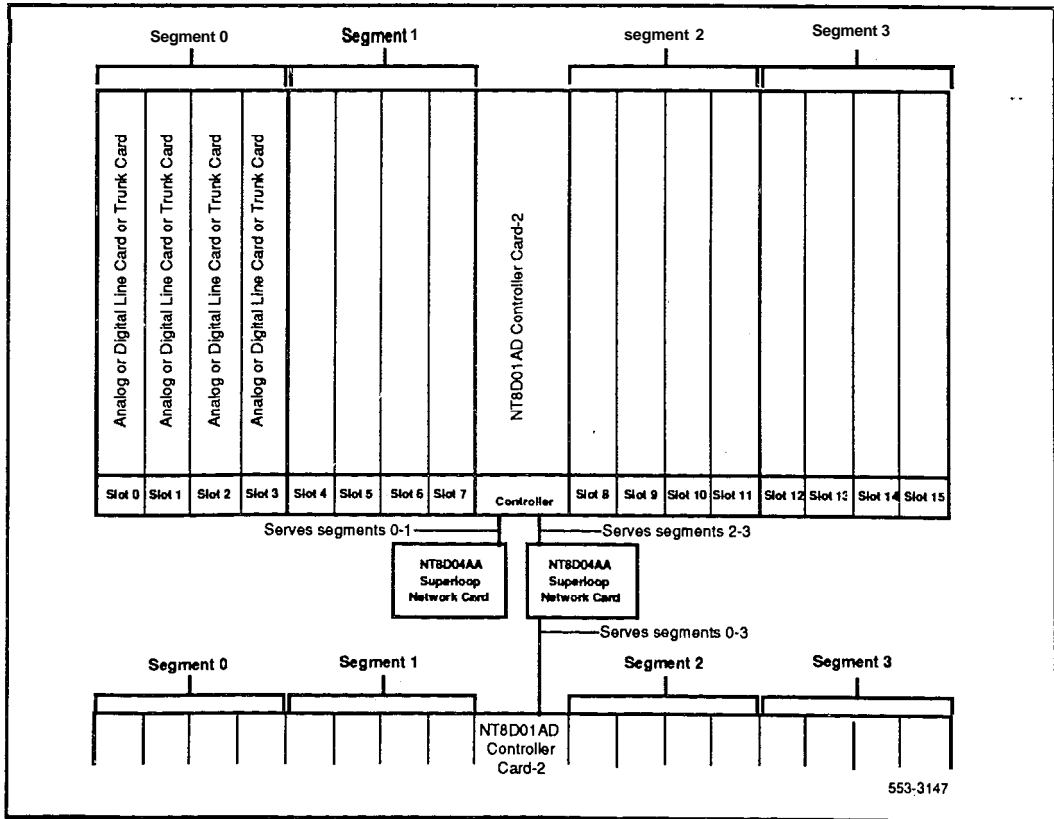

Peripheral Equipment

Peripheral Equipment (**PE**) performs analog to digital conversion of all input signals before switching is performed by the network. Pulse Code Modulation (**PCM**) is used to convert analog signals to digital signals. This conversion method samples the amplitude of the analog signal at a rate of twice the highest signal frequency then converts the amplitude into a series of coded pulses. Eight **kHz** is the PCM sampling frequency standard for telecommunications.

Companding (compressing-expanding) PCM is a standard technique for using 8 bit words to efficiently represent **the** range of voice and data signals. Two standards for **companding**, A-Law and μ -Law, are recognized worldwide. Meridian 1 codecs conform to both standards and are software selectable (for Intelligent Peripheral Equipment). The codecs are also designed to pass signals up to 3.4 **kHz** with minimum time delay and low phase distortion, a requirement for the proper transmission of data signals.

Peripheral Equipment is provisioned on network loops based on traffic requirements. The traffic requirements of PE cards provisioned on a particular network loop must be matched to the traffic capacity of that loop to achieve optimal utilization of network traffic capacity.

Meridian SL-1 PE cards are housed in the **NT8D13** PE Module. **Meridian 1** Intelligent Peripheral Equipment (**IPE**) cards are housed in the **NT8D37 IPE** Module or the **NT8D11** Common/Peripheral Equipment Module. The PE and **IPE** cards cannot be mixed in a module.

Intelligent Peripheral Equipment includes:

- Controller Cards, which provide timing and control sequences, and monitoring capabilities
- Analog and digital line and trunk cards, which provide interfaces to equipment outside the SL-1 modules (such as telephone sets, data terminals, and trunks)

Table 1 lists the intelligent peripheral cards housed in the IPE Module and the number of Terminal Numbers (**TNs**) each supports.

Table 1
Intelligent Peripheral Equipment

Intelligent Peripheral Equipment cards	Number of TNs
Controller Cards:	
NT8D01 Controller Card-4	N/A
NT8D01 Controller Card-2	N/A
Line Cards:	
NT8D02 Digital Line Card	16 to 32
NT8D03 Analog Line Card	16
NT8D09 Message Waiting Line Card	16
Trunk Cards:	
NT8D14 Universal Trunk Card	8
NT8D15 E&M Trunk Card	4
Note: TN density per segment is 16 to 128 TNs , with 64 to 512 TNs per IPE Module. The maximum TN density assumes all slots are equipped with NT8D02 Digital Line Cards with 16 voice and 16 data TNs provisioned. A typical mix of line and trunk cards yields a nominal density of 64 TNs per segment, 256 TNs per IPE Module.	

Remote Peripheral Equipment

In a local operating environment, Peripheral Equipment may be housed up to 50 feet from the Common Equipment. Remote Peripheral Equipment (**RPE**) extends this range, allowing approximately 70 miles between local and remote facilities.

This extension is made possible by converting multiplexed loop signals to a form compatible with the commonly used T-1 type digital transmission system. The circuit cards required are housed in the **NT8D47** Remote Peripheral Equipment Carrier Module.

Any medium which conforms to the DS-1 format (1.544 Mbps) may be used to link local and remote sites, including digital microwave radio and fiber optic transmission systems.

Software architecture

Software programs are instruction sequences that control call processing, administration, and maintenance functions. Several SL-1 generic software programs, with optional feature packages, are available to satisfy varying requirements.

Resident programs

Resident programs are always available in memory during system operation. Some resident programs are permanently programmed into ROM system memory. Other resident programs are automatically loaded into system **memory** at system power-up.

Resident programs include:

- Error Monitor: continuously monitors call processing
- Initialize Program: locates faults and rebuilds data, and **releases** reserve memory areas
- Overlay Loader: locates, checks, and loads programs into the overlay area
- Overload Monitor: monitors the volume of system messages and determines where overloads occur
- Resident Trunk Diagnostic: monitors all trunk calls
- System Loader: loads resident programs from the mass storage unit into system memory at power-up
- Traffic: examines system schedule, transfers traffic data from accumulating to holding registers, and outputs reports

Non-resident programs

Non-resident programs, often called overlays or loads, are stored on the mass storage unit. These programs are loaded into the overlay area automatically or manually by the Overlay Loader program. Programs are loaded automatically if the system requests use of the overlay area when it detects a fault, or if the program is scheduled to run. Programs are loaded manually, for administrative and maintenance purposes, through user commands.

There are three main types of programs:

- Feature administration (service change) programs are used to create or modify all aspects of the system, from individual key assignments on a telephone set to complete system configurations.
- Diagnostic programs are used:
 - manually for status checking, equipment testing, and fault clearing
 - automatically as part of a scheduled maintenance routine (Midnight Routines) and when the overlay area is not in use (Background Routines)
- Traffic measurement programs accumulate data during system operation to determine efficient utilization of the system and to detect congestion problems.

Only one program may be loaded at a time. The program may be run concurrently with normal call processing without interfering with **system-traffic**.

Only one system terminal can input into the overlay area at a time. More than one I/O device, however, can receive output simultaneously. A terminal may be configured as an input only or output only device.

Product description

Chapter contents

Meridian 1 SL-1 Systems	28
System option 21 A	28
System option 21	30
System option 51	32
System option 61	34
System option 71	36
Column hardware	38
Modules	39
Pedestal	-- 49
Top Cap	49
Spacer Kit	50

Meridian 1 SL-1 Systems

There **are** four principle Meridian 1 SL-1 system types available:

- System option 21: Single CPU
- System option 51: Single CPU, half network group
- System option 61: Dual CPU, full network group
- System option 71: Dual CPU, multiple network groups

In addition, there is system option 21A: a single CPU, one module configuration optimized for small system applications.

Each system option is made up of basic hardware elements: the module, Pedestal, and Top Cap. These elements, including each type of **module**, are described in “Column hardware.”

System option 21A

Table 2 lists specifications for system option 21A. Figure 10 shows this system option.

Table 2
System option 21 A specifications

Power	AC only
Average number of ports	160
Maximum number of modules	1
AC input voltage	208 V ac
Number of CPUs	1
Number of network loops	7 Superloops or 12 PE loops plus two service loops (Conference/TDS)
Memory	Error correcting 1.5 Mb
Software generic	1011 Release 15

—continued—

Table 2
System option 21A specifications (continued)

Base hardware:	
<ul style="list-style-type: none">• Common/Peripheral Equipment Module (one)	<ul style="list-style-type: none">• Floppy Disk Unit• System Monitor (NT7D15)• Network/DTR Card• Conference/TDS Card• Serial Data Interface paddle boards (two)
<ul style="list-style-type: none">• Pedestal	<ul style="list-style-type: none">• Power Distribution Unit (NT8D53AD)
<ul style="list-style-type: none">• Top Cap	<ul style="list-style-type: none">• Top Cap Fans (two)• Thermostat Harness

Figure 10
System option 21A

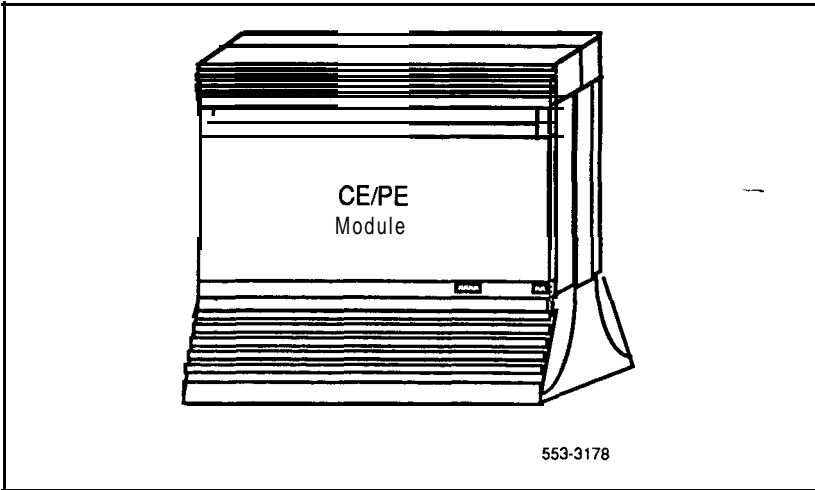

System option 21

Table 3 lists the specifications for system option 21. Figure 11 shows a typical configuration for this system option.

Table 3
System option 21 specifications

Power	AC or DC
Maximum number of ports	800
Input voltage	208 V ac or - 48 V dc
Number of CPUs	1
Number of network loops	6 Superloops or 12 PE loops plus two service loops (Conference/TDS)
Memory	Error correcting 1.5 Mb
Software generic	1011 Release 15
Base hardware:	
. Common/Peripheral Equipment Module (one)	<ul style="list-style-type: none"> . Floppy Disk Unit . Network/DTR Card . Conference/TDS Card . Serial Data Interface paddle boards (three)
. Pedestal	<ul style="list-style-type: none"> . System Monitor (NT8D22) . Power Distribution Unit . Blower or Fan Unit
. Top Cap	<ul style="list-style-type: none"> . Air Probe Harness . Thermostat Harness

Figure 11
System option 21

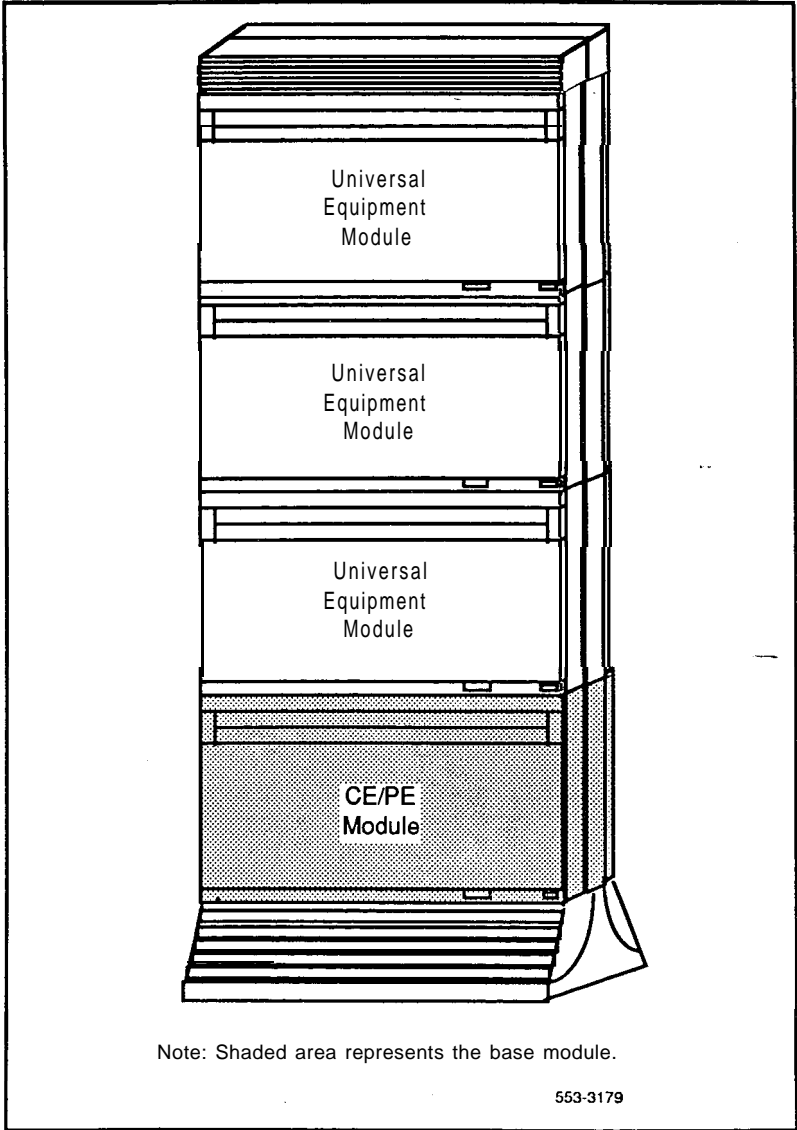

System option 51

Table 4 lists the specifications for system option 51. Figure 12 shows a typical configuration for this system option.

Table 4
System option 51 specifications

Power	AC or DC
Maximum number of ports	1000
Input voltage	208 V ac or - 48 V dc
Number of CPUs	1
Number of network loops	16
Memory	2.2 Mb
Software generic	1111 Release 15
Base hardware:	
<ul style="list-style-type: none"> . CPU/Network Module (one) . Intelligent Peripheral Equipment Module (one) . Pedestal . Top Cap 	<ul style="list-style-type: none"> . Floppy Disk Unit or Multi Disk Unit . Superloop Network Card (one) . Conference/TDS Card . Serial Data Interface paddle boards (two) . System Monitor (NT8D22) . Power Distribution Unit . Blower Unit . Air Probe Harness . Thermostat Harness

Figure 12
System option 51

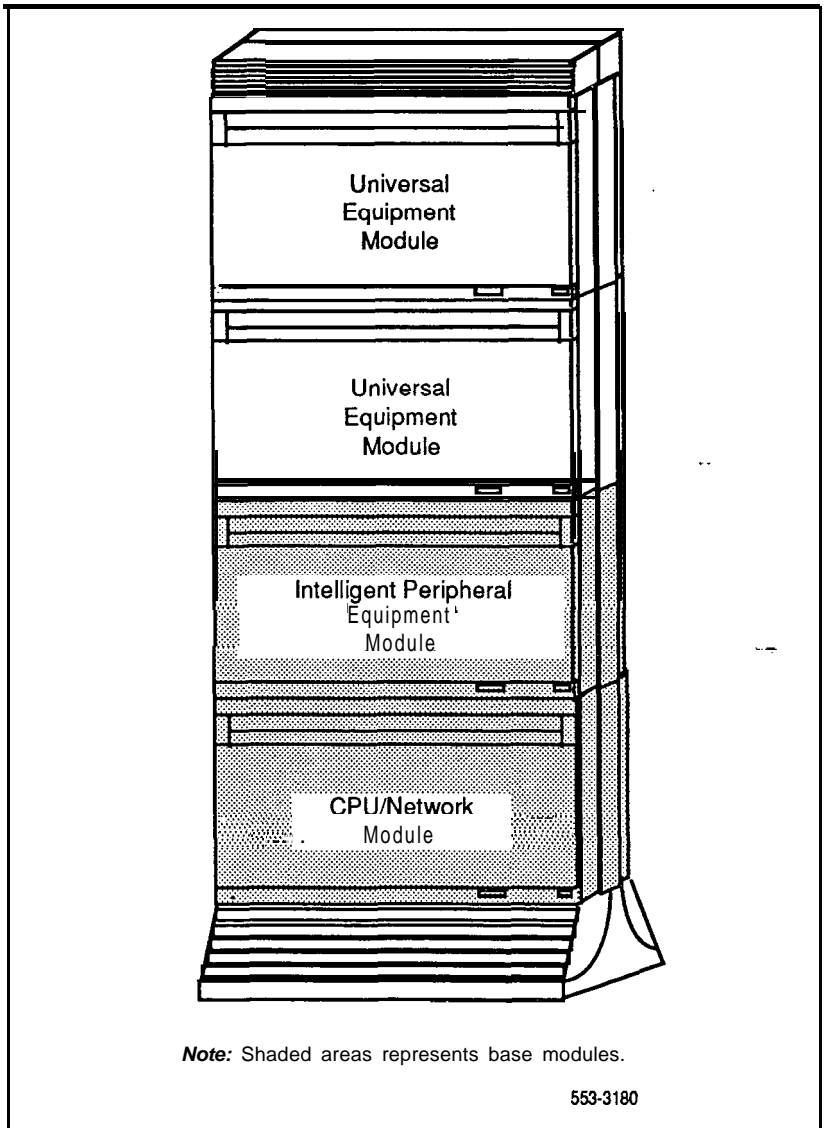

System option 61

Table 5 lists the specifications for system option 61. Figure 13 shows a typical configuration for this system option.

Table 5
System option 61 specifications

Power	AC or DC
Maximum number of ports	2000
Input voltage	208 V ac or - 48 V dc
Number of CPUs	2 (redundant)
Number of network loops	32
Memory	redundant 2.2 Mb
software generic	1111 Release 15
Base hardware:	
. CPU/Network Modules (two)	. Floppy Disk Unit or Multi Disk Unit
. Intelligent Peripheral Equipment Module (one)	. Superloop Network Card (one)
	. Conference/TDS Cards (two)
	. Serial Data Interface paddle boards (two)
. Pedestal	. System Monitor (NT8D22)
	. Power Distribution Unit
	. Blower Unit
. Top Cap	. Air Probe Harness
	. Thermostat Harness

Figure 13
System option 61

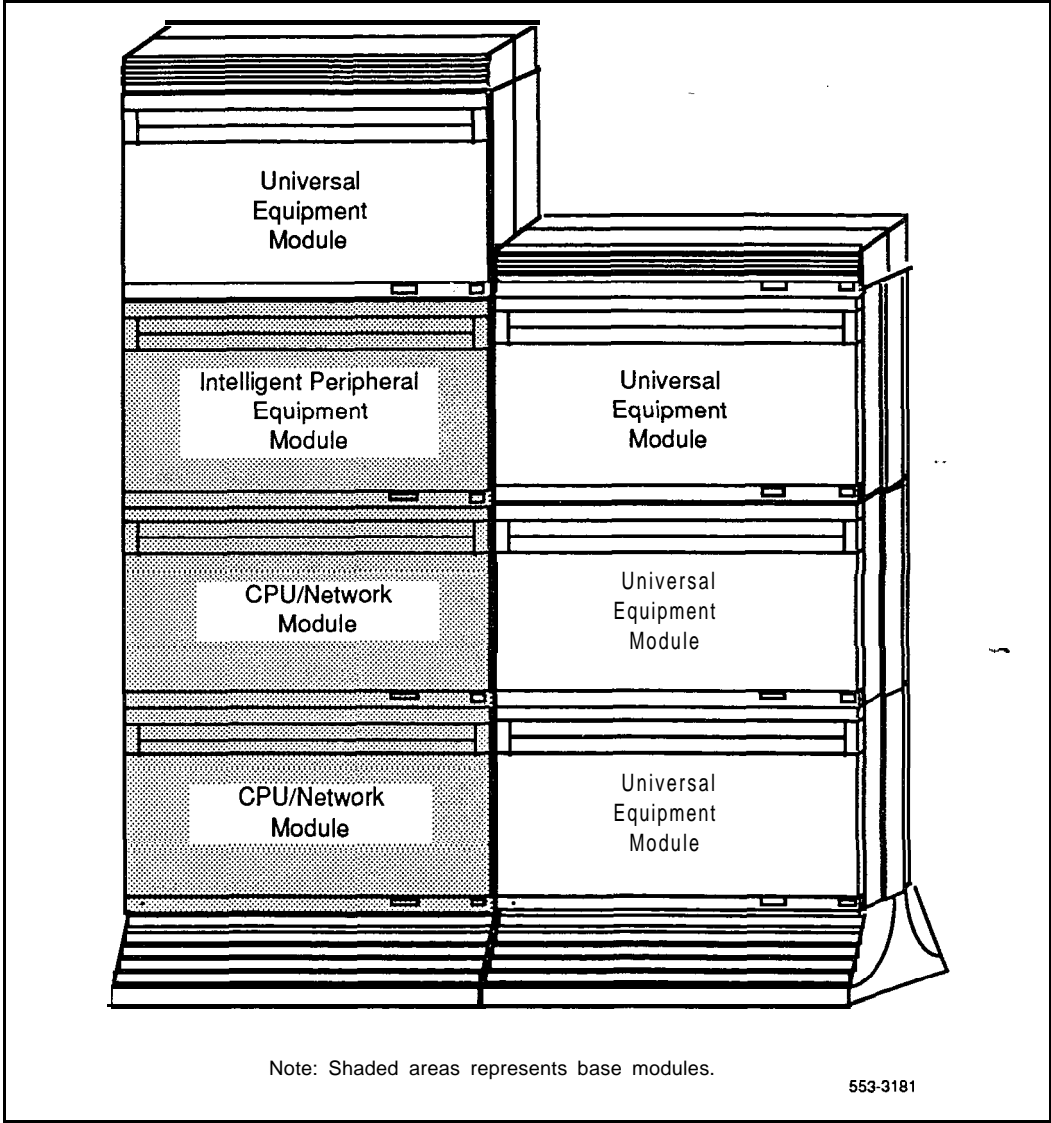

System option 71

Table 6 lists the specifications for system option 71. Figure 14 shows a typical configuration for this system option.

Table 6
System option 71 specifications

Power	AC or DC
Maximum number of ports	10,000
Input voltage	208 V ac or - 48 V dc
Number of CPUs	2 (redundant)
Number of network loops	160
Memory	4.5 Mb
Software generic	1211 Release 15
Base hardware (two columns)	
. CPU Modules (two)	. Floppy Disk Unit or Multi Disk Unit
. Network Modules (two)	. Superloop Network Card (one)
. intelligent Peripheral Equipment Modules (two)	. Conference/TDS Cards (two)
. InterGroup Module (one)	. Serial Data Interface paddle boards (two)
. Pedestals (two)	One per Pedestal
	. System Monitor (NT8D22)
	. Power Distribution Unit
	. Blower Unit
. Top Caps (two)	One per Top Cap
	. Air Probe Harness
	. Thermostat Harness

Figure 14
System option 71

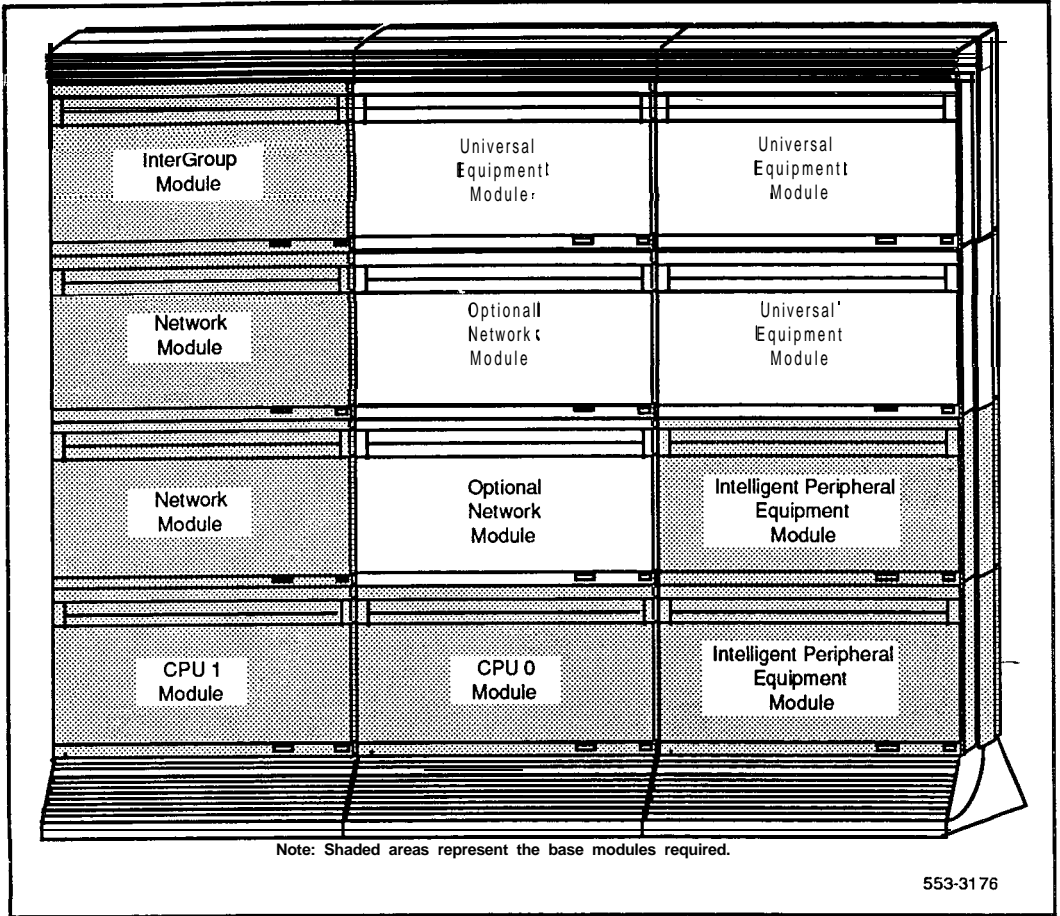

Column hardware

The basic unit of the Meridian 1 SL-1 System is the Universal Equipment Module (UEM). Equipped modules are stacked one on top of another to form a column. Each column contains a Pedestal, a Top Cap, and up to four modules; each level of modules is called a tier (see Figure 15). A system may have one column or multiple columns. For compliance with FCC standards for EMI/RFI, Spacer Kits are provided to interconnect the columns in a multi-column system.

Figure 15
Column hardware

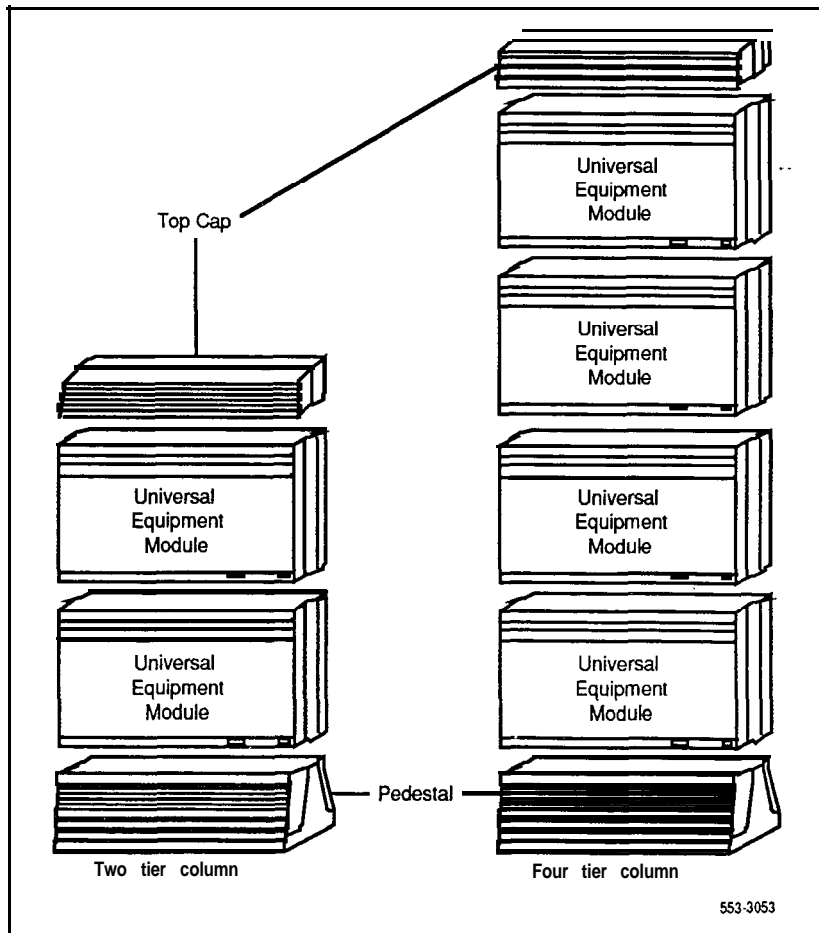

Modules

Universal Equipment Modules (**UEMs**) are constructed of die cast aluminum for strength and durability. For easy access to circuit cards, each module has removable front and rear covers. When a UEM is equipped to support a system function, it becomes a specific type of module, such as a CPU Module or Network Module. Each type of module contains everything needed (card cage, backplane, power supply, input/output cabling, etc.) to support its specific system function.

All cable routing between the module and the Main Distribution Frame (**MDF**), also called the cross-connect terminal, is handled through the rear of the module. Cables can exit at the top, accessing overhead cable racks, or at the bottom, taking advantage of raised floors.

The following Meridian 1 SL- 1 System modules are available:

- NT6D39 CPU/Network Module
- NT8D11 Common/Peripheral Equipment Module
- NT8D13 Peripheral Equipment Module
- NT8D34 CPU Module
- NT8D35 Network Equipment Module
- NT8D36 InterGroup Module
- NT8D37 Intelligent Peripheral Equipment Module
- NT8D47 Remote Peripheral Equipment Carrier Module
- NT6D44 Meridian Mail Module

NT6D39 CPU/Network Module

The CPU/Network Module houses Common Equipment circuit cards (CPU and Network Equipment) in system options 51 and 61. Each CPU/Network Module houses up to 16 network loops. System option 51, a single CPU, half network group system, requires one CPU/Network Module. System option 61, a dual CPU, full network group system, requires two CPU/Network Modules.

The CPU/Network Module-is equipped with three backplane slots used by the NT8D4 1 Serial Data Interface paddle board. The module contains 18 card slots (see Figure 16) which support:

- slots 1 - 8: Superloop Network Card; QPC414 Network Card; Conference/TDS; Primary Rate Interface; Serial Data Interface
- slot 9: Clock Controller or Serial Data Interface
- slot 10: Peripheral Signaling
- slot 11: 3-Port Extender
- slot 12: Floppy Disk Interface or Mass Storage Interface
- slot 13: Serial Data Interface
- slot 14: CPU Function
- slot 15: CPU Interface
- slot 16: Changeover Memory Arbitrator
- slot 17: Memory
- slot 18: Floppy Disk Unit or Multi Disk Unit

Figure 16
NT6D39 CPU/Network Module -typical configuration (AC power)

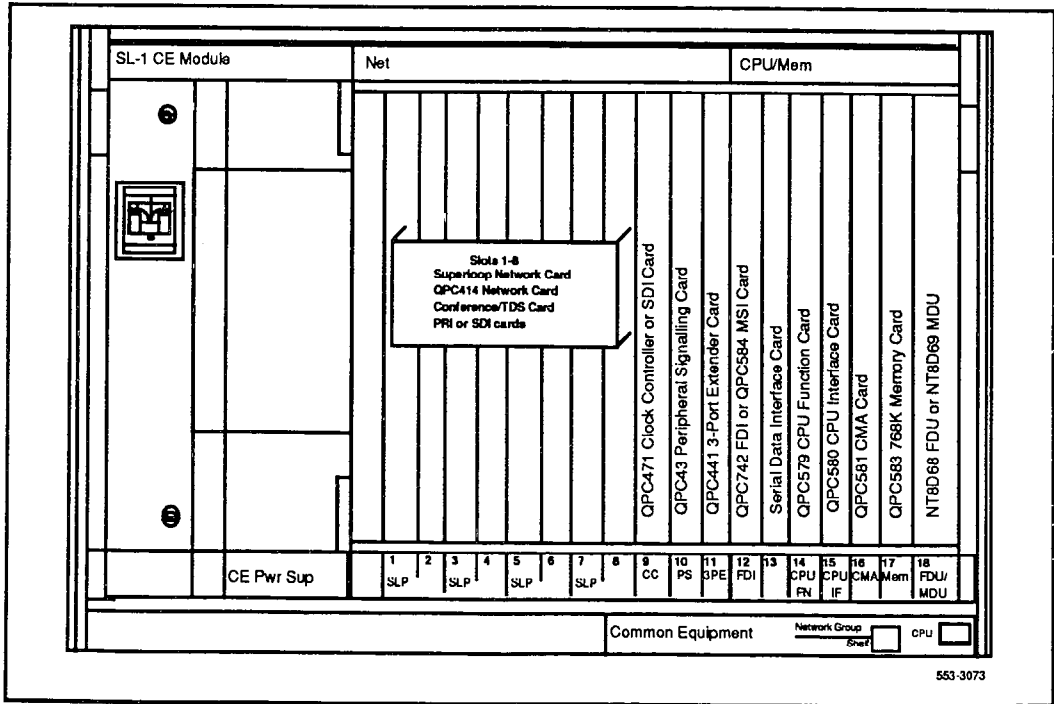

NT8D11 Common/Peripheral Equipment Module

The Common/Peripheral Equipment (CE/PE) Module houses CPU, Network, and Intelligent Peripheral Equipment (IPE) circuit cards in system option 21.

Note: The CE/PE Module does not support Meridian SL- 1 PE cards. They are housed in the NT8D13 Peripheral Equipment (PE) Module.

The CE/PE Module is equipped with three backplane slots used by the NT7D15 System Monitor and NT8D41 Serial Data Interface paddle board. The module provides ten slots for Common Equipment cards and ten slots for Intelligent Peripheral Equipment cards (see Figure 17):

- slot 1 (CPU/Mem): Floppy Disk Interface
- slot 2 (CPU/Mem): CPU Card
- slot 3 (CPU/Mem): Memory/Peripheral Signaling
- slots 4-9 (Net): Superloop Network Card; QPC414 Network Card; Conference/TDS (slot 4 only); Clock Controller (slots 4-7 only)
- slot 10 (Net): Network/DTR
- slots 0-9 (IPE): Intelligent Peripheral Equipment cards
- the Floppy Disk Unit may be installed in any three adjacent open slots

Figure 17
NT8D11 CE/PE Module -typical configuration

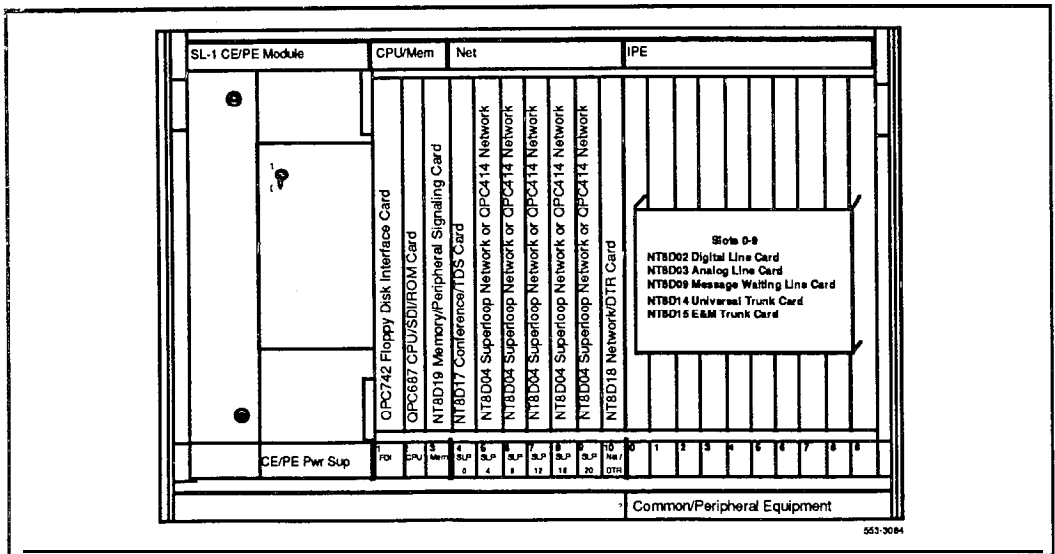

NT8D13 Peripheral Equipment Module

The Peripheral Equipment (PE) Module houses the QPC659 Dual Loop Peripheral Buffer Card and Meridian SL-1 PE cards (including Meridian Data Service cards). The PE Module interfaces with the QPC414 Network Card. This module can be used with all system options (system option 21A must be upgraded for compatibility).

Note: The PE Module does not support Intelligent Peripheral Cards. They are housed in an **NT8D11** Common/Peripheral Equipment Module or **NT8D37** Intelligent Peripheral Equipment (IPE) Module.

The Peripheral Buffer Card must be installed in the card slot labeled *Cont* (for Controller). Slots 1-10 can house any Meridian SL-1 PE card. (See Figure 18.)

Figure 18
NT8D13 PE Module -typical configuration (AC power)

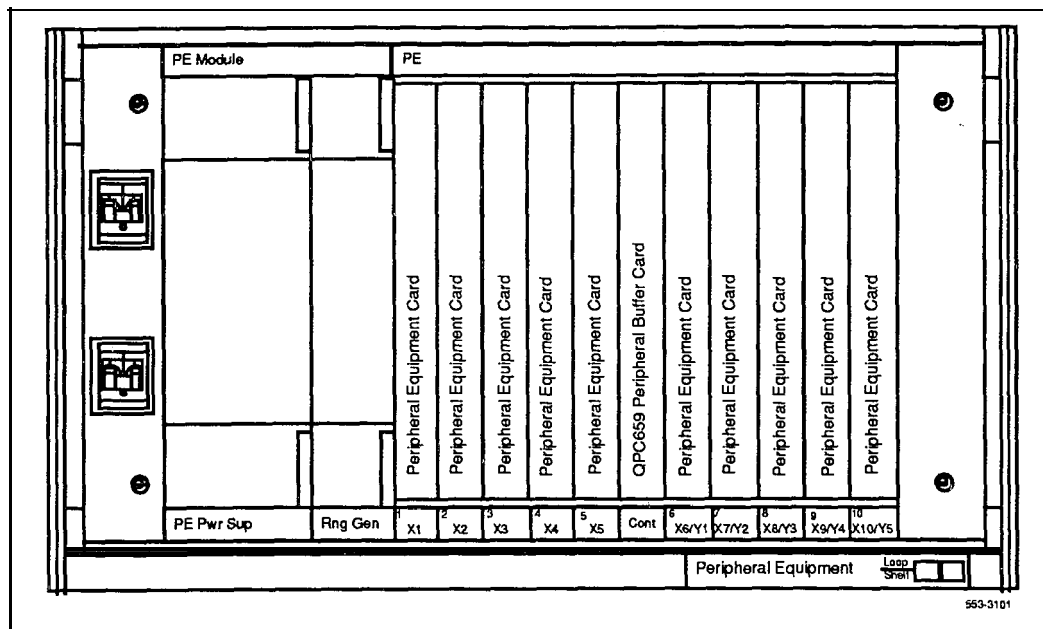

NT8D35 Network Module

The Network Module houses Network Equipment cards in **system** option 7 1. The module houses up to eight QPC414 Network Cards or four NT8D04 Superloop Network Cards, or a combination of the two, for a total of 16 network loops. In a typical configuration, one **Conference/TDS** Card is configured in the module, leaving 14 voice/data loops available.

Two Network Modules are required to make a full network group of 32 loops. A maximum of ten Network Modules (five network groups) may be configured in system option 7 1.

The Network Module contains 15 card slots (see Figure 20) which support:

- slots 1: 3-Port Extender
- slots 2-3: InterGroup Switch; Primary Rate Interface; Serial Data Interface
- slot 4: Peripheral Signaling
- slots 5-12: Superloop Network Card; QPC414 Network Card; Conference/TDS; Primary Rate Interface; Serial Data Interface
- slots 13-14: Primary Rate Interface or Serial Data Interface
- slot 15: not used

Figure 20
NT8D35 Network Module -typical configuration (AC power)

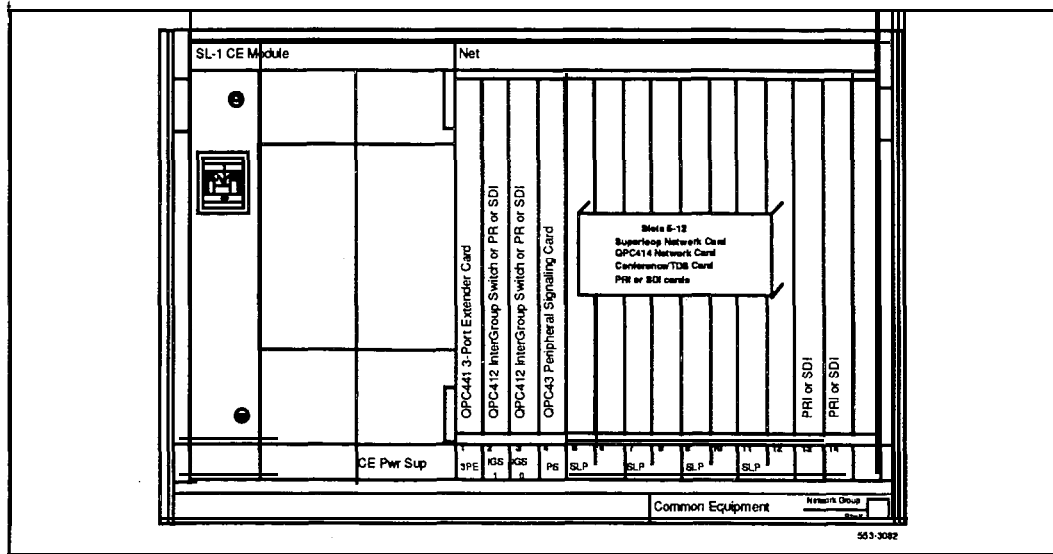

NT8D36 InterGroup Module

The **InterGroup** Module provides a path for switching traffic between network groups in system option 71. Faceplate cables **from** the Segmented Bus Extender, Clock Controller, and **InterGroup** Switch circuit cards are connected to the **InterGroup** Module (see Figure 21).

The **InterGroup** Module does not require an internal power supply. Therefore, there is no AC or DC version of the module.

Figure 21
NT8D36 InterGroup Module

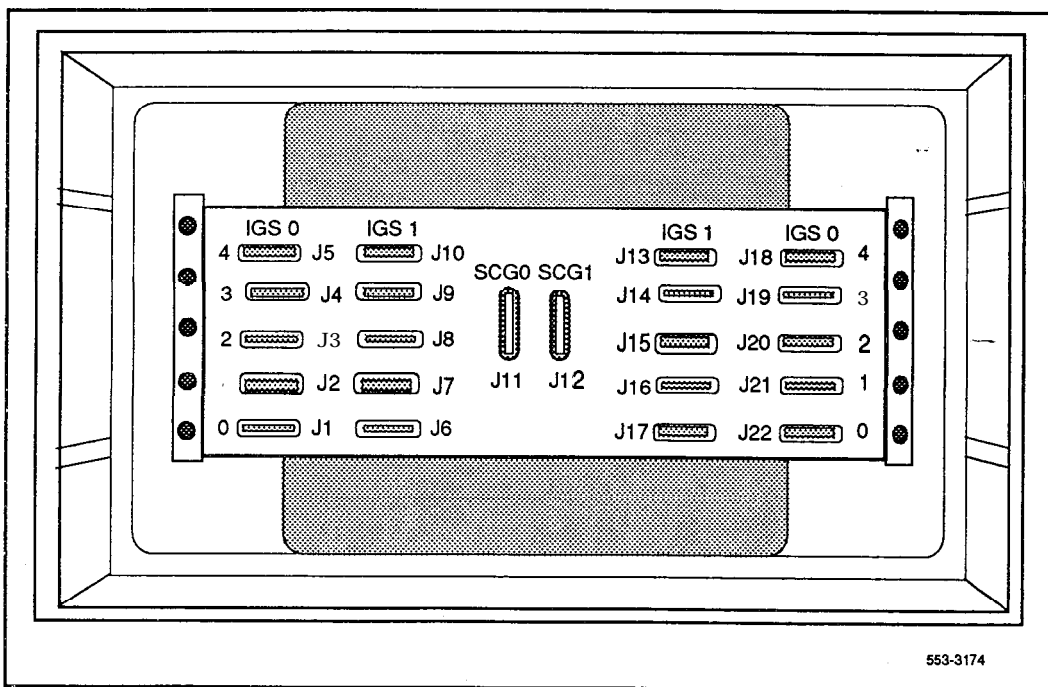

NT8D37 Intelligent Peripheral Equipment Module

The Intelligent Peripheral Equipment (IPE) Module houses the NT8D01 Controller Card, NT8D16 Digitone Receiver Card, and Meridian 1 IPE cards. The IPE Module interfaces with the NT8D04 Superloop Network Card. This module can be used in all system options (system option 21A must be upgraded for compatibility).

Note: The IPE Module does not support Meridian SL-1 PE cards. They are housed in the NT8D 13 Peripheral Equipment (PE) Module.

The Controller Card must be installed in the card slot labeled *Cont.* Slots 0- 15 can house a **Digitone** Receiver Card or any Meridian 1 IPE card. (See Figure 22.)

Figure 22
NT8D37 IPE Module -typical configuration (AC power)

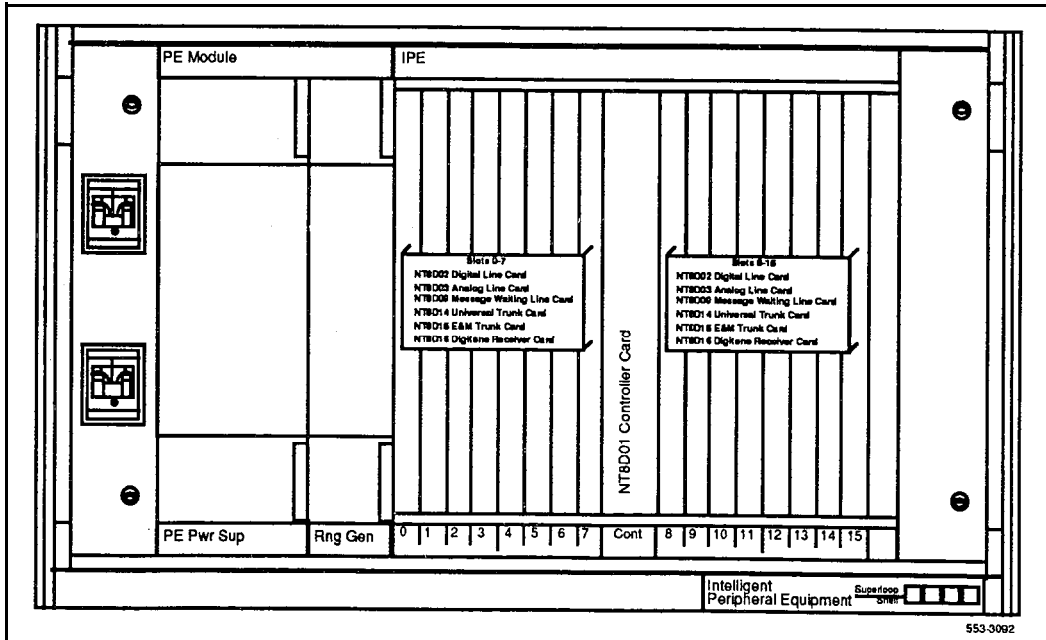

NT8D47 Remote Peripheral Equipment Carrier Module

The Remote Peripheral Equipment (RPE) Carrier Module is used in conjunction with the NT8D13 PE Module. The RPE Module extends the Network to PE interconnection distance between local and remote sites. This module can be used with all system options (system option 21A must be upgraded for compatibility).

The RPE Module accommodates two network loops. The number of RPE modules required per system depends on the number of stations at the remote site.

The RPE module contains 12 card slots (see Figure 23) which support:

- slots 1 and 11-12: Primary Rate Interface (not related to RPE function)
- slots 2 and 9: 1.5 Mb Converter
- slots 3 and 8: 2 Mb Converter
- slots 4 and 7: Carrier Interface
- slot 5: Remote Peripheral Switch
- slot 6: Local Carrier Buffer
- slot 10: Carrier Maintenance

Figure 23
NT8D47 RPE Carrier Module -typical configuration (AC power)

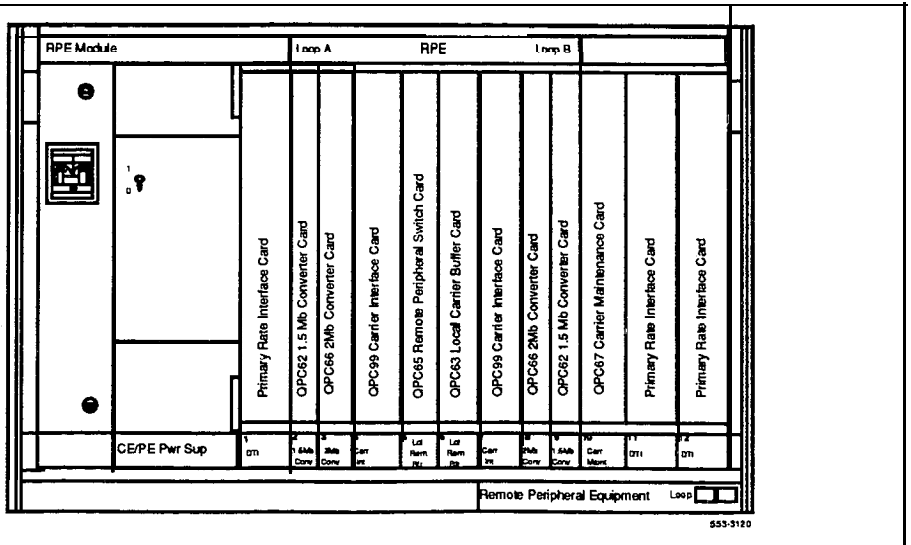

NT6D44 Meridian Mail Module

The Meridian Mail Module houses the circuit cards which support the Meridian Mail feature. The Meridian Mail Module must be connected to a **QPC414 Network Card**. This module can be used with all system options (system option 21A must be upgraded for compatibility).

Figure 24 shows the card slot arrangement in the Meridian Mail Module.

Figure 24
Meridian Mail Module -typical configuration

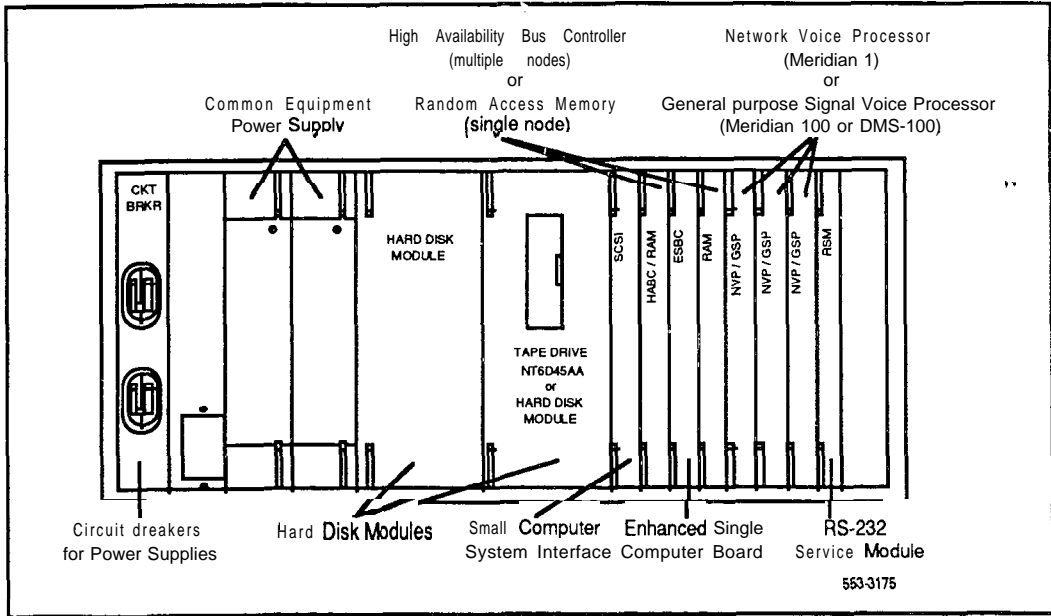

Pedestal

Each column includes a Pedestal. Each Pedestal houses a Blower or Fan Unit, an Air Filter, the Power Distribution Unit (which contains the column circuit breakers), and the System Monitor. (The Pedestal in system option 21A houses only the Power Distribution Unit.)

The Pedestal is approximately 31.5 inches wide by 25.5 inches deep by 10 inches high and weighs 30 pounds empty. Each Pedestal is equipped with leveling feet (a caster option is available for up to two tiers).

Input power for the system is brought into the Power Distribution Unit (PDU) in the Pedestal. The PDU distributes the input power to the column.

There are three versions of the Pedestal:

- NT8D27AB AC systems
- NT7D09AA DC systems
- NT8D27AC system option 21A

Top Cap

The Top Cap is mounted on the top module of each column. It provides airflow exits, EMI/RFI shielding, I/O cable entry and exit, and overhead cable-rack mounting. The Top Cap covers thermal sensor assemblies for the column.

The Top Cap is approximately 31.5 inches wide by 22 inches deep by 3 inches high and weighs 8 pounds. It consists of a center support section and front and rear air exhaust grills.

There are three versions of the Top Cap:

- NT7D00AA AC systems
- NT7D00BA DC systems
- NT7D00AC system option 21A

Spacer Kit

The NT8D49 Spacer Kit bolts modules together (see Figure 25) and provides EMI/RFI shielding in multiple column systems. The Spacer Kit includes an expansion spacer, gaskets, and bushings.

Figure 25
Multi-column system with spacers

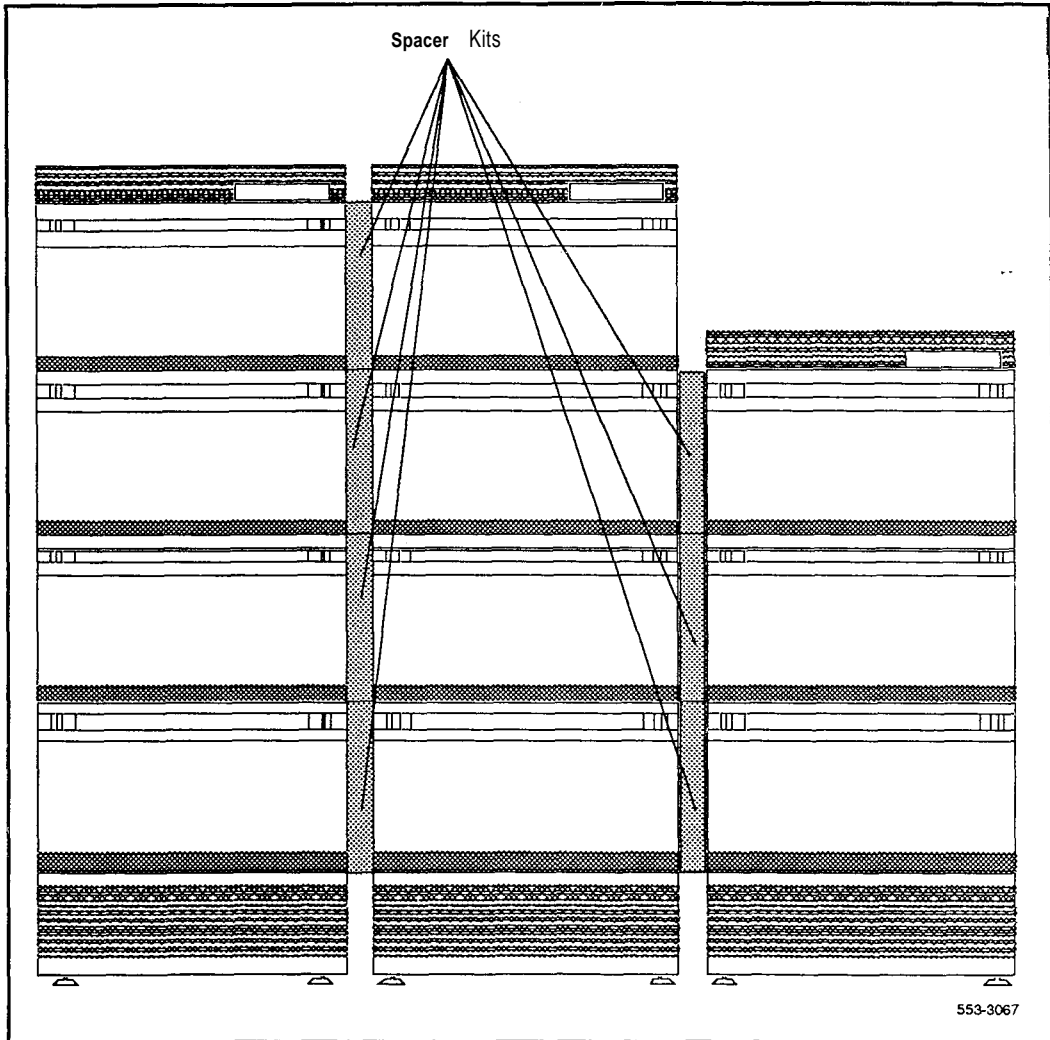

List of terms

AC

Alternating current.

ACD

Automatic Call Distribution.

ADM

Add-On Data Module.

AIM

Asynchronous Interface Module.

ALU

Arithmetic Logic Unit.

Architecture

The interrelationship between the parts of a system. The framework of a system.

ASIM

Asynchronous/Synchronous Interface Module.

Analog

A process which models information in the form of a continuously varying parameter such as current, voltage, or phase.

Analog signal

A signal that varies in a continuous manner such as voice or music. An analog signal may be contrasted with a digital signal which represents only discrete states. The signal put out by a data set has both analog and discrete characteristics.

ANI

Automatic Number Identification.

Ampere

A unit of electrical current or the rate of flow of electricity which is equal to watts divided by volts.

Backplane

A printed circuit board that extends across the length of the card cage and connects to the circuit card connectors. Also known as a motherboard.

Battery back-up

System power furnished by stand-by batteries that are charged by a charger. If commercial power fails, the batteries will maintain service for a limited period of time determined by the size of the batteries and the traffic on the system.

BTU

British Thermal Unit. The quantity of heat required to raise the temperature of one pound of water one degree Fahrenheit at a specified temperature (as 39° F). Also means Bus Terminating Unit.

Capacity

The information-carrying ability of a telecommunications facility, group, network, or system measured in Bits Per Second (bps).

Cards

See circuit cards.

Card cage

A frame for holding circuit cards in a module. Also called a card chassis.

CAS

Centralized Attendant Service.

CASM

Centralized Attendant Service, Main.

CASR

Centralized Attendant Service, Remote.

CC

Clock Controller (may also mean Controller Card).

CDR

Call Detail Recording.

CE

Common Equipment.

Central Office (CO)

The site where a telephone company terminates customer lines and locates the switching equipment which interconnects those lines.

Central Processing Unit (CPU)

The main portion of a computer that contains the primary storage, arithmetic and logic units, and the control unit (may also mean a mainframe computer).

Centralized depot

A repair house that serves subdepots.

Centrex

Central Exchange. A PBX type of service provided through equipment at a telephone company site.

Circuit cards

Circuit cards carry the electronics for particular functions (memory, disk drive control, switching functions, etc.). Most circuit cards are installed in specialized slots in a card cage and connect to the backplane. (Also called circuit packs or boards.)

CMA

Changeover and Memory Arbitrator.

c o

Central Office.

CPU

Central Processing Unit.

Common equipment (CE)

A hardware subsystem that houses one or more Central Processing Units (CPUs), memory cards, mass storage units, and service cards..

Configuration

A group of machines (hardware) which are interconnected and are programmed to operate as a system.

DC

Direct current.

Data Terminal Equipment (DTE)

Equipment or devices capable of transmitting and/or receiving data signals over a communications network.

dB

Decibel

DCHI

ISDN D-Channel Handler Interface.

Diagnostic programs

Software routines used to test equipment and identify faulty components.

Digital

A process which models information as discrete values of some parameter such as voltage, current, or phase.

Digital Multiplex Switching System (DMS)

A family of Northern Telecom switching systems that provides digital circuit switched service for voice and data transmission. DMS is characterized by the use of pulse code modulation (PCM) and time division multiplexing (TDM) throughout the switched network. The system allows the direct switching of PCM signals without their conversion to analog format.

Digital signal

A signal made up of discrete, non-continuous pulses whose information is contained in the duration, periods, and/or amplitude.

Directory number (DN)

The four-digit number or extension given to a telephone **set**.

**DSL**

Digital Subscriber Loop.

DTE

Data Terminal Equipment.

DTI

Digital Trunk Interface.

DTR

Digitone Receiver.

EIA

Electronics Industry Association.

EMI

Electromagnetic Interference. Unwanted electromagnetic coupling, such as a ham radio heard on an electric organ or church music heard in hearing aids. Also known as QRM or "static."

ESN

Electronic Switched Network.

Failure rate

The estimated number of failures for an item during one million (10⁶) hours of operation.

Firmware

A set of instruction sequences stored permanently in hardware (ROM).

FM

Frequency Modulation. A process where the frequency of a previously single frequency carrier wave is varied in step with the amplitude of a complex modulating wave.

**Frame**

A distributing **frame**. The structure on which all distribution and trunk cables into a Central Office are terminated (attached).

Frequency Division Multiplexing (FDM)

Combining two or more information channels into a single transmission channel by assigning each information channel an exclusive frequency band within the transmission channel bandwidth. (See "Multiplex" and "Time Division Multiplex.")

I/O

Input/Output. Exchange between a machine and end user equipment

I/O Channel

Input/Output channel. A component in a computer system controlled by the Central Processing Unit that handles the transfer of data between main storage and peripheral equipment.

I/O Panel

A separation plane that prohibits Radio Frequency (RF) emissions from passing through a module and provides mounting for I/O cable connectors.

ISDN

Integrated Services Digital Network.

IVD

Integrated Voice and Data.

Kbps

Kilobits per second.

Line

A communications channel or circuit; an electrical path.

Loop

A bidirectional path between network equipment and peripheral equipment.

MCDS

Multi-Channel Data System.

MDF

Main Distributing Frame. (See "Frame.")

M F

Multi-Frequency. A method of sending numerical address digits between telephone company switching centers coded as two or more frequencies between 300 and 3400 Hertz.

MFS

Multi-Frequency Signaling or Multi-Frequency Sender.

MGS

Multi-Group Switch.

MSI

Mass Storage Interface.

MSU

Mass Storage Unit.

Multiplex (MUX)

The process of combining **two** or more information channels into **a** single transmission channel. (See "Frequency Division Multiplexing" and "Time Division Multiplexing.")

Network Equipment

A hardware subsystem that provides digital multiplexed switching for voice, data, and signaling paths.

NFT values

The number of spares required for a field-replaceable item. **NFT** is calculated by multiplying the number (**N**) of the item by the failure rate (**F**) for the item by the turnaround time (**T**) in hours. $N \times F \times T = \text{NFT value}$.

NTP

Northern Telecom Publication.

ODAS

Office Data Administration System. This system provides a method of retrieving administrative information stored in SL-1 memory.

Office Data

Office Data represents system configuration data, peripheral equipment data, and transient data (temporary) used for call processing.

PBX

Private Branch Exchange.

PCM

Pulse Code Modulation.

PDU

Power Distribution Unit. Input power for a Meridian 1 SL-1 System is brought into the Pedestal to the PDU. The PDU distributes input **power** to the column.

PE

Peripheral Equipment.

Pedestal

The bottom element in a column. Each Pedestal houses a Blower or Fan Unit, an Air Filter, the Power Distribution Unit (which contains the column circuit breakers), and the System Monitor. (The Pedestal in system option 21A houses only the Power Distribution Unit).

Peripheral Equipment (PE)

A hardware subsystem that provides analog and digital line and trunk interfaces and houses a combination of line, trunk, and receiver circuit cards.

Power supplies

Individual power units that generate the different DC voltages required by the cards installed in each module.

PRA

ISDN Primary Rate Access.

PRI

ISDN Primary Rate Interface.

Private Branch Exchange

PBX. A telephone switching center that provides telephone service within an organization and connects to the public telephone network.

Private Exchange

A telephone exchange that provides telephone service within an organization but-not to the public telephone network.

PROM

Programmable Read-Only Memory.

Public Switched Network

The Direct Distance Dialing (DDD) telephone network or any telephone exchange type of service for public use.

Pulse Code Modulation (PCM)

A modulation technique where the signal is converted from an analog to digital format by sampling the signal at periodic intervals and digitizing the amplitude into a finite number of discrete levels.

RAM

Random Access Memory. A storage system or computer memory accessible by the user for either storing or retrieving information. RAM is volatile memory.

Redundancy

The duplication of software, or hardware, or both (such as redundant CPUs) used as a standby in case one fails.

Retrofit

Furnish with new parts or equipment not available at the time of manufacture.

RF

Radio Frequency. A group of electromagnetic energy waves whose lengths are between the audio range and the light range.

RH

Relative Humidity.

ROM

Read Only Memory. Storage system or computer memory that is "burned into" the microprocessor chip and can be read, but not written to or modified. Non-volatile memory.

RPE

Remote Peripheral Equipment.

Satellite operation

The operation of a telecommunications system at a remote location as a completely unattended system connected to the main system by special point-to-point circuits. The two (or more) systems act as one total system served by attendants at the main system.



SBE

Segmented Bus Extender.

SDI

Serial Data Interface.

SEQ

Sequencer.

Software

A set of programmed instruction sequences stored either as resident programs in system memory or as non-resident programs stored on disk and loaded into memory when needed.

Software generic

A term used to identify SL-1 software packages. Each software generic (X11, for example) has a series of releases (like Release 15).

--

Sparing interval

The period of time that stocks of replaceable items should last without being replenished.

Stock confidence level

The allowed probability of not being out of stock when the sparing interval of one year is greater than 99.9 percent.

System hardware

Hardware configuration.

System Monitor

A microprocessor-based circuit card which controls and monitors the status of cooling equipment and power-related hardware and functions.



TDS

Tone and Digit Switch.

Time Division Multiplexing (TDM)

Combining two or more information channels into a single transmission channel by assigning each information channel an exclusive periodic transmission time interval. (See "Multiplex" and "Frequency Division Multiplex.")

Top Cap

The Top Cap is mounted on the top module of each column. It provides airflow exits, **EMI/RFI** shielding, I/O cable entry and exit, and overhead cable-rack mounting. The Top Cap covers thermal sensor assemblies for the column.

3PE

Three-Port Extender,

Trunk

A single circuit between two points, both of which are switching centers or individual distribution points.

TTY

Teletypewriter machine.

UEM

Universal Equipment Module. A modular, self-contained hardware cabinet that houses a card cage, power supply, backplane, circuit cards, and other basic equipment. When it is equipped, the UEM becomes a specific type of module, such as a CPU Module or Network Module.

UPS

Uninterrupted Power Supply.

VAC

Voltage Alternating Current.

VDC

Voltage Direct Current.

VDT

Video Display Terminal or monitor.



ε

0.0001

SL-1

System options 21, 51, 61, 71

System overview

Copyright © 1990 Northern Telecom

All rights reserved.

Information subject to change without notice.

Release 2.0

Standard

February 28, 1990

Printed in U.S.A.



553-3001-210

SL-1

System options 21, 51, 61, 71

System installation procedures
Standard

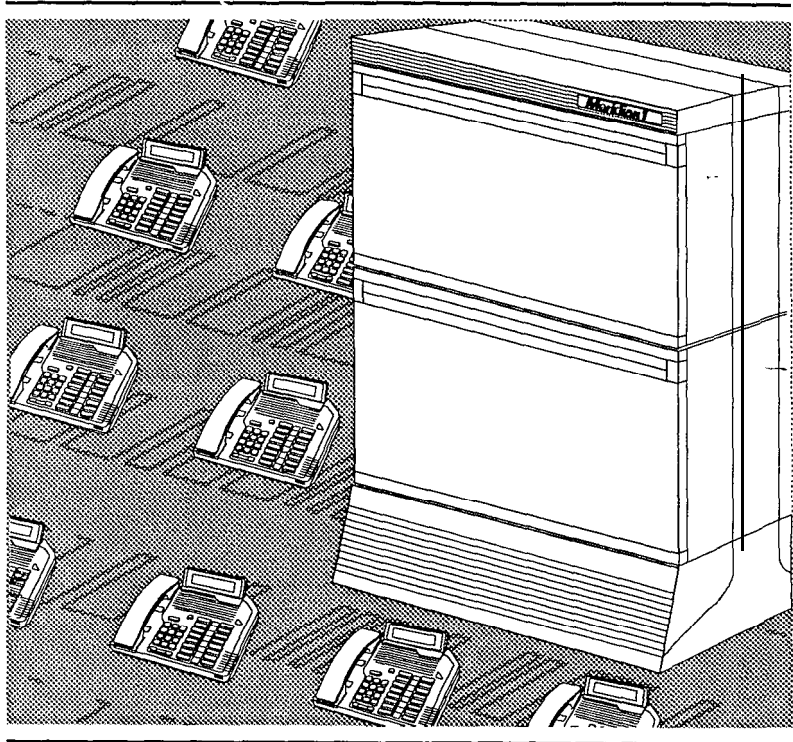

nt northern
telecom

Meridian 1
Communication Systems





SL-1

System options 21, 51, 61, 71

System installation procedures

Publication number: 553-3001-210

Document release: 2.0

Document status: Standard

Date: February 28, 1990



© 1990 Northern Telecom

All rights reserved

System installation procedures 553-3001-210

Revision history

January 29, 1990

Standard. release 1.0

February 28, 1990

Standard, release 2.0

About this document

This document provides installation and acceptance testing procedures for pre-assembled SL-1 system options **21, 51, 61**, and 71, and procedures for the addition of Universal Equipment Modules to operating option **21, 51, 61**, and 71 systems.

References

See the *SL-1 planning & engineering guide* for

- *Master index* (553-3001-000)
- *System overview* (553-3001-100)
- *Installation planning* (553-3001-120)
- *System engineering* (553-3001-151)
- *Power engineering* (553-3001-152)
- *Spares planning* (553-3001-153)
- *Equipment identification and ordering* (553-3001-154)

See the list of line and trunk circuit descriptions in the *Master index* (553-3001-000) for specific references to lines and trunks.

See the *SL-1 installation and maintenance guide* for

- *System installation procedures* (553-3001-210)
- *Circuit pack installation and testing* (553-3001-211)
- *Installation procedures for telephone sets and attendant consoles* (553-3001-215)
- *Extended systems installation* (553-3001-250)

- **Disk drive upgrade procedures** (553-3001-251)
- **General maintenance information** (553-3001-500)
- **Fault clearing** (553-3001-510)
- **Hardware replacement** (553-3001-520)

See the *SL-1 X11 software guide* for an overview of software architecture, procedures for software installation and management, and a detailed description of all X11 features and services. This information is contained in two documents:

- ***X11 software management*** (553-3001-300)
- ***X11 features and services*** (553-3001-305)

See the *SL-1 X11 input/output guide* (553-3001-400) for a description of all administration programs, maintenance programs, and system messages.

Contents

Procedure 1: Installing a pre-assembled SL-1	1-1
Procedure 2: Installing earthquake anchors	2-1
Procedure 3: Installing a Universal Equipment Module (UEM)	3-1
Procedure 4: Positioning and levelling equipment	4-1
Procedure 5: Installing an overhead cable rack	5-1
Procedure 6: Mounting NT6D52 rectifiers	6-1
Procedure 7: Installing a battery distribution box	7-1
Procedure 8: Installing and testing ground wiring	8-1
Procedure 9: Adjusting and connecting NT6D52 rectifiers	9-1
Procedure 10: Installing a reserver power system	10-1
Procedure 11: Connecting DC power to a UEM from a QBL15	11-1
Procedure 12: Connecting DC power to a UEM from a QBL12 or a QCA13	12-1
Procedure 13: Installing a Serial Data Interface (SDI) port	13-1
Procedure 14: Installing an administration and maintenance terminal	14-1
Procedure 15: Installing a disk drive	15-1
Procedure 16: Designating the cross-connect terminal	16-1
Procedure 17: Installing a Power Fail Transfer Unit (PFTU)	17-1
Procedure 18: Installing System Monitor cabling	18-1
Procedure 19: Cabling Common Equipment in system option 61	19-1
Procedure 20: Cabling Common Equipment in system option 71	20-1
Procedure 21: Installing network loop cabling	21-1
Procedure 22: Cabling NT8D11 CE/PE modules to the cross-connect terminal	22-1

Procedure 23: Cabling NT8D37 and NT8D13 PE modules to the cross-connect terminal	23-l
Procedure 24: Connecting lines and trunks at the cross-connect terminal	24-i
Procedure 25: Connecting trunks and telephones to the PFTU	25-l
Procedure 26: System power-up and initial loading	26-l
Procedure 27: Testing UEM power supplies	27-l
Procedure 28: Blower unit and thermal sensor tests	28-l
Procedure 29: System loading (SYSLOAD) tests	29-l
Procedure 30: Power Fail Transfer Unit (PFTU) test	30-l
Procedure 31: Terminal test	31-l
Procedure 32: Disk drive test	32-l

Procedure 1

Installing a pre-assembled SL-1 system

General information

This procedure directs you to the information required to install and test a pre-assembled SL-1 system.

For proper installation, you must perform the steps in this procedure in the order given. Telephone sets and terminal equipment may be installed in parallel **with** other system components if desired. See **Installation procedures for telephone sets and attendant consoles** (553-3001-215) for telephone set and console installation procedures.

Refer to Northern Telecom Publications 169-2191-200 and 169-2181-200 (for NT5C03 rectifiers) for installation information when QCA13 power cabinets are required to supply DC power. When possible, power cabinets should be installed prior to beginning the system installation.

Batteries, when required, should be installed according to the manufacturer's instructions.

System installation procedure

--

- 1 Unpack and inspect equipment.

<p style="text-align: center;">WARNING</p> <p>A fully loaded equipment column weighs more than 500 pounds (228 kg). Get help to remove equipment from shipping pallet.</p>

- Place equipment in a safe, dry location in or near the equipment room.
- If equipment is mounted on a shipping pallet, follow unpacking instructions provided with the packaging material and remove equipment from the pallet.

- Cut any remaining strapping and/or tape. Remove transport protection devices and stretch wrap film (if provided) from equipment.
 - Inspect equipment for physical damage. Report any damage to supplier.
 - Inventory all system components by comparing the system order form to **the** packing slip received with the equipment. Every item on the order form should also appear on the packing slip.
- 2** Prepare floors for earthquake bracing if required. See **Procedure 2: Installing earthquake anchors**, for detailed installation instructions.
 - 3** Install any remaining **UEMs** according to equipment room floor plan. See **Procedure 3: Installing a Universal Equipment Module (UEM)**, for detailed installation instructions.
 - 4** Position, level, and designate equipment according to equipment room floor plan. See **Procedure 4: Positioning and levelling equipment**, for detailed installation instructions.
 - 5** Install overhead cable rack assembly if provided. See **Procedure 5: Installing an NT8D63AA Overhead Cable Tray Kit**, for detailed installation instructions.
 - 6** Install power supplies in all **UEMs**. Make sure that **the** switches on all power supplies and Module Power Distribution Units (**MPDU**) are set to **OFF**, and that the system is not connected to any power source.
 - 7** Install the **NT7D12AA** rectifier rack if **NT6D52** enclosed rectifiers are provided. See **Procedure 6: Mounting NT6D52 rectifiers**, for detailed installation instructions.
 - 8** Install **QBL12** or **QBL15** battery distribution box if provided, and connect to battery string. See **Procedure 7: Installing a battery distribution box and connecting to batteries**, for detailed installation instructions.
 - 9** Install and test personal hazard ground and system ground wiring. See **Procedure 8: Installing and testing ground wiring**, for detailed installation instructions.

- 10 Connect NT6D52 enclosed rectifiers, if provided, to the QBL15 battery distribution box. See **Procedure 9: Adjusting and connecting NT6D52 rectifiers**, for detailed installation instructions.
- 11 Install reserve power system if provided. See **Procedure IO: Installing a reserve power system**, for detailed installation instructions.
- 12 This step applies only to DC-powered systems.
Install a junction box (if required) for the power wiring and connect the DC power source to the equipment columns.
 - For systems equipped with a QBL15 battery distribution box, see **Procedure 11: Connecting DC power to a UEM from a QBL15 power/battery distribution box**, for detailed installation instructions.
 - For systems equipped with a QBL12 battery distribution box or a QCA13 power cabinet, see **Procedure 12: Connecting DC power to a UEM from a QBL12 power/battery distribution box or a QCA13 power cabinet**, for detailed installation instructions.
- 13 Install system terminal. See **Procedure 13: Installing an administration and maintenance terminal**, for detailed installation instructions.
- 14 Install serial data interface port. See **Procedure 14: Installing a Serial Data Interface (SDI) port**, for detailed installation instructions.
- 15 Install disk drive unit. See **Procedure 15: Installing a disk drive unit**, for detailed installation instructions.
- 16 Install and designate the cross-connect terminal. See **Procedure 16: Designating the cross-connect terminal**, for detailed installation instructions.
- 17 Install Power Fail Transfer Unit (PFTU). See **Procedure 17: Installing a Power Fail Transfer Unit (PFTU)**, for detailed installation instructions.
- 18 Install System Monitor cabling. See **Procedure 18: Installing System Monitor cabling** for detailed installation instructions.

- 19 Install Common Equipment cabling:
 - For SL-1 system options 21 and 51, no Common Equipment cabling is required.
 - For SL-1 system option 61, see **Procedure 19: Cabling Common Equipment in system option 61**, for detailed cabling information.
 - For SL-1 system option 71, see **Procedure 20: Cabling Common Equipment in system option 71**, for detailed cabling information.
- 20 Install network loop cabling.
 - For SL-1 system option 21, the peripheral equipment portion of the NT8D11 CE/PE UEM is served by the NT8D18AA Network/DTR card. There is no cabling between the NET/DTR card and the peripheral equipment cards in the module. No action is required beyond inserting the NET/DTR card in its assigned slot, assigning network loop 28 in software, and enabling the NET/DTR card.
 - For a system option 21 also equipped with NT8D37 or NT8D13 PE modules, see **Procedure 21: Installing network loop cabling** for detailed cabling instructions for these modules.
 - For SL-1 system options 51, 61, and 71, see **Procedure 21: Installing network loop cabling** for detailed installation instructions.
- 21 Cable Peripheral Equipment modules to the main cross-connect terminal.
 - For SL-1 system option 21, see **Procedure 22: Cabling NT8D11 CE/PE modules to the cross-connect terminal**, for cabling information.
 - For a system option 21 also equipped with NT8D37 or NT8D13 PE modules, see **Procedure 23: Cabling NT8D37 and NT8D13 PE modules to the cross-connect terminal**, for cabling information for these modules.
 - For SL-1 system options 51, 61, and 71, see **Procedure 23: Cabling NT8D37 and NT8D13 PE modules to the cross-connect terminal**, for cabling information.

- 22 Cross-connect lines and trunks at the main cross-connect terminal.
 - For SL-I system option 21, see **Procedure 22: Cabling NT8D11 CE/PE modules to the cross-connect terminal**, for detailed cross-connect information.
 - For a system option 21 also equipped with NT8D37 or NT8D13 PE modules, see **Procedure 24: Connecting lines and trunks at the cross-connect terminal**, for detailed cross-connect information for these modules.
 - For SL-1 system options 51, 61, and 71, see **Procedure 24: Connecting lines and trunks at the cross-connect terminal**, for detailed cross-connect information.
- 23 Connect trunks and telephone sets to the Power Fail Transfer Unit. See **Procedure 25: Connecting trunks and telephones to the PFTU**, for detailed installation instructions.
- 24 Inspect equipment.
 - All circuit packs must be in their assigned positions.
 - All circuit pack option switches and plugs must be properly set. See the chapter “Option Switch Settings” in **Circuit pack installation and testing** (553-3001-211) for complete switch setting information for all circuit packs.
 - All circuit packs must be properly seated and locked.
 - All cable connectors must be secured.
 - All UEMs and equipment columns must be properly designated.
 - All circuit breakers must be set to **OFF**.
 - All cosmetic panels must be in place.
 - All faceplate switches must be set to **ENB** or **NORM**.
- 25 Power-up system and load system software. See **Procedure 26: System power-up and initial loading**, for detailed instructions.

26 Perform system acceptance tests.

- Test all UEM power supplies. See **Procedure 27: Testing UEM power supplies**, for detailed test instructions.
- Test Blower unit. See **Procedure 28: Blower unit and thermal sensor tests**, for detailed test instructions.
- Test manual system loading (SYSLOAD). See **Procedure 29: System loading (SYSLOAD) test**, for detailed test instructions.
- Test Power Fail Transfer Unit, if equipped. See **Procedure 30: Power Fail Transfer Unit (PFTU) test**, for detailed test instructions.
- Test maintenance and administration terminal. See **Procedure 31: Terminal test**, for detailed test instructions.
- Test disk drive unit. See **Procedure 32: Disk drive test**, for detailed test instructions.
- Test all equipped circuit packs. See **Circuit pack installation and testing (553-3001-211)** for individual circuit pack test procedures.

27 Install **sets** and consoles. See **Installation procedures for telephone sets and attendant consoles** (553-3001-215) for detailed telephone set and console installation procedures.

Procedure 2: Installing earthquake anchors

General Information

Use this procedure to locate and install bolt anchors in concrete floors for earthquake bracing.

WARNING

Safety goggles should be worn when drilling the anchor holes. Holes should be drilled using the appropriate tools, following local practices.

A PO709207 floor layout template is required to mark the location of the anchor holes. Each hole is then equipped with an anchor to secure the pedestals to the floor.

When choosing bolts, make sure that they are long enough to penetrate the mounting holes normally used for the levelling feet (approximately 3 1/4") and to hold securely in the bolt anchors.

Two types of anchors are available to meet the particular requirements of various types of concrete floors. Table 2-1 lists three suitable bolt/anchors.

Table 2-1
Earthquake brace anchors

Bolt/Anchor	Minimum embedment	Bolt diameter
Hilti Kwik Bolt	2 3/4 in. (70 mm)	1/2 in.
Hilti HVA STD Bolt	4 1/4 in. (110 mm)	1/2 in.
Redhead Wedge	6 in. (155 mm)	1/2 in.

Installing floor anchors

- 1 Determine which type of bolt/anchor is required from Table 2-1.
- 2 Using the template illustrated in Figure 2-1, mark the location of **the** anchor holes for all the pedestals. Note that the template is designed to show **the** location of the four anchor holes for one pedestal and the two first anchor holes in the neighboring pedestal, taking into account the space required between columns for an expansion kit. Move the template and mark the location of anchor holes for all pedestals being installed.

CAUTION

Avoid drilling through the floor or through reinforcing bars. If the floor thickness will not support the depth required by the anchor, or a reinforcing bar is encountered, notify the building facilities supervisor immediately.

- 3 Drill the holes to the minimum embedment according to Table 2-1.
- 4 Remove any debris from the anchor holes.
- 5 Install the anchors as illustrated in Figure 2-2.
- 6 Remove the bolts from the anchors.
- 7 Cover the anchor holes to prevent debris from falling into the holes if equipment columns are not to be installed immediately.
- 8 If possible, prepare each column to be installed by removing the four levelling **feet** from each **pedestal** and drilling the feet mounting holes to a size of **9/16"**. If it is not possible to drill the feet mounting holes at this time, make sure that the drilling is **performed** before attempting to position pedestals in **their** final location.

Figure 2-2
Anchor bolt installation

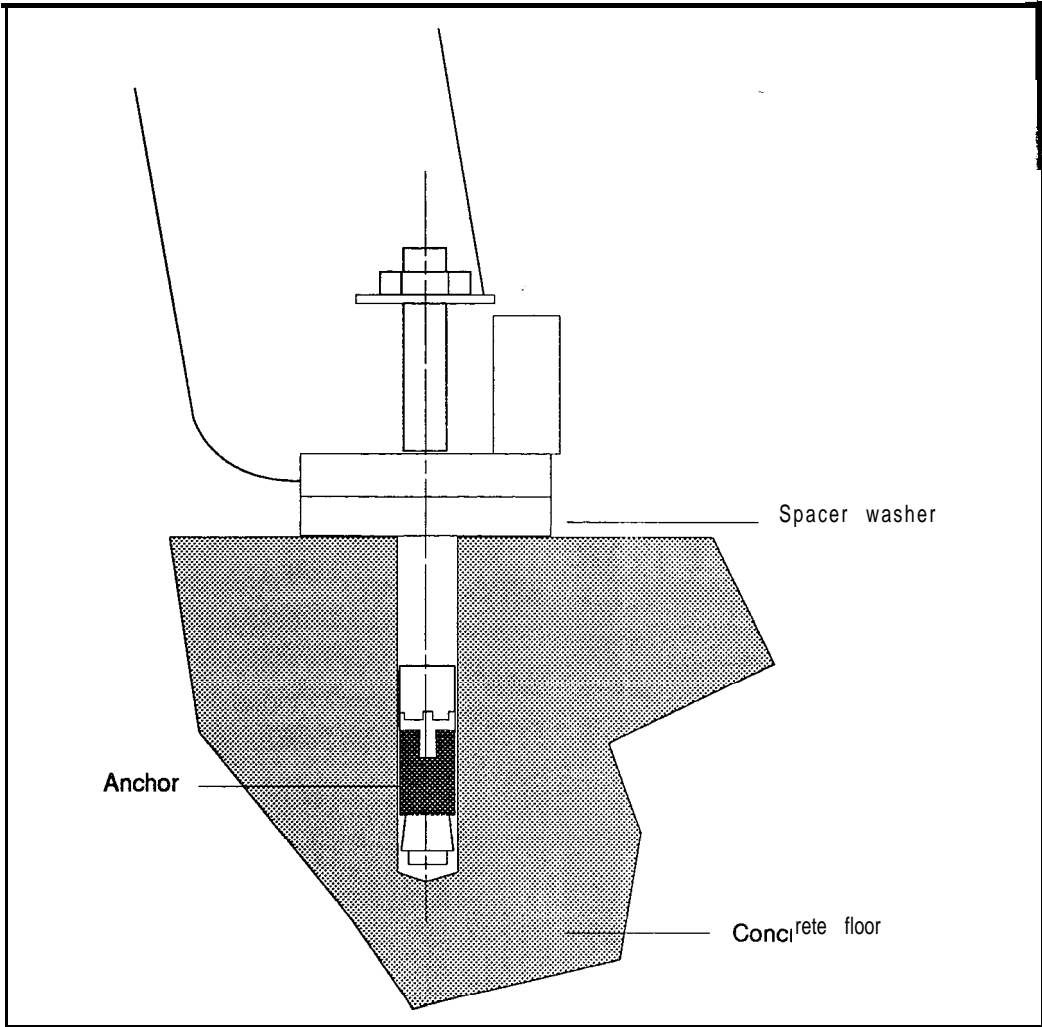

Procedure 3: Installing a Universal Equipment Module (UEM)

General information

Use this procedure to add a Universal Equipment Module (UEM) to a pedestal or equipment column.

WARNING

A fully loaded UEM weighs approximately 90 kg. (200 lbs). Obtain assistance when placing a UEM onto a column. If desired, circuit packs may be removed, tagged, and temporarily stored elsewhere to lighten the UEM.

- 1 When adding a UEM to a column equipped with a top cap, remove the top cap and top panel.
 - Remove front air exhaust grill from the top cap. The air exhaust grill is secured by two clips underneath the front edge of the grill (see Figure 3-1). Pull the clips forward to remove the grill.
 - Use a 5/16" socket wrench to remove the front set of three screws securing the top cap to the UEM directly below it. Figure 3-2 illustrates the top cap assembly, showing the locations of the screws.
 - Remove the rear air exhaust grill.
 - Remove the rear set of three screws securing the top cap to the UEM
 - Remove the rear air intake grill from the pedestal and set the column circuit breakers to OFF. See Figures 3-3 and 3-4.
 - Unlatch and remove the rear cover from the top UEM.
 - Use a 5/16" screwdriver to remove the four screws securing the I/O panel cover at the rear of the top UEM, as shown in Figure 3-7, and remove the cover.
 - Remove the top cap from the column and place it in a safe location.

- If the existing UEM is equipped with an earthquake bracing kit, remove the two tie bars across the top of the UEM as shown in Figure 3-12. Unscrew the two rods on each side of the UEM and remove them. Note that not all **UEMs** are equipped with an earthquake bracing kit.
 - Disconnect the system monitor cable which runs from the connector **labelled J2** at the rear of the top UEM to the top panel, as shown in Figures 3-7 and 3-8.
 - Disconnect the power cable which runs from the top UEM to the top panel, as shown in Figures 3-7 and 3-8.
 - Use a **5/16"** socket wrench to remove the screw securing the alarm LED mounting bracket to the top left front corner of the existing UEM. See Figure 3-2.
 - Remove the top panel and place it in a safe location.
- 2 Position and secure the new UEM on the desired column:
- Locate the positioning guides on the lower UEM (or pedestal) and ensure that the new UEM is facing in the same direction as the column. See Figure 3-5.
 - Place the UEM on top of the column and adjust until seated securely on the positioning guides. Cables leaving through the top of the column from existing **UEMs** may have to be rearranged through the openings between the existing and new **UEMs**. See Figure 3-5 for cable opening locations.
 - Use a **9/16"** socket wrench to bolt the new UEM to the **UEM** below it (or to the pedestal) with five mounting bolts. See Figure 3-6.
- 3 Connect the UEM to UEM power cable.
- Remove the four screws securing the I/O panel cover at the rear of the UEM being added.
 - If the new UEM is being installed on top of an existing UEM, remove the four screws securing the I/O panel cover at the rear of the existing UEM and remove the cover. See Figure 3-7.

- Connect the power cable from the new UEM to the connector near the top of the lower UEM (or to the power cable connector in the top of the pedestal if installing the UEM on a pedestal) as shown in Figures 3-7 through 3-10.
- 4 Connect the system monitor cable from the connector **labelled J1** at the rear of the new UEM to the connector **labelled J2** at the rear of the UEM directly below it (or to the monitor cable connector in the top of the pedestal if installing the UEM on a pedestal). See Figures 3-9 and 3-10 for connector locations.
- 5 Reinstall **the I/O** panel covers at the rear of each **UEMs** (if removed).
- 6 Place the top panel on the top of the new UEM and mount the bracket for the LED over the top panel with two screws as illustrated in Figure **3-2**.
- 7 If the UEM is being added to a system which already has earthquake bracing installed, remove the existing earthquake rods and insert new earthquake rods of the correct length on each side of the UEM, as shown in Figure 3-12. If the UEM is being added at the time of initial system installation, **see Procedure 4: Positioning and levelling equipment**, for earthquake bracing installation.

It may be necessary to remove the end panels from the UEM to position the rods. The end panels are held by four bolts located on the inside of the UEM (two at the front under the cosmetic panel and two at the rear). Secure the rods in the threaded holes in the top of the pedestal. Reinstall the two tie bars on the top of the column.

There are three different lengths of earthquake rods:

- **NT8D64AA** earthquake bracing kit with rods for two-tier columns
- **NT8D64AB** earthquake bracing kit with rods for three-tier columns
- **NT8D64AC** earthquake bracing kit with rods for four-tier columns

The slightly flattened end of the rod should be positioned at the top of the column to allow **tightening** of the rod with a wrench or pliers.

If required, reinstall the end panels on the UEM.

- 8 Connect the system monitor **cable** from the top panel to connector **J2** at the rear of the new UEM as shown in Figures 3-7 and 3-8.
- 9 Connect the power cable from **the** new UEM to the top panel, as shown in Figure 3-8.
- 10 Place the top cap on the new UEM and use a **5/16"** socket wrench to secure the six mounting screws as shown in Figure 3-2. Make sure that the indentation on the bottom of the top cap faces towards the **front** of the UEM and over the bracket and wiring for the alarm LED.
- 11 Replace the exhaust grills on the top cap.
- 12 Set the column circuit breakers to ON.
- 13 Replace the air intake grill at the rear of the pedestal (see Figure 3-3). If work operations for the **UEMs** are completed, install the remaining covers.

Figure 3-1
Air exhaust grill

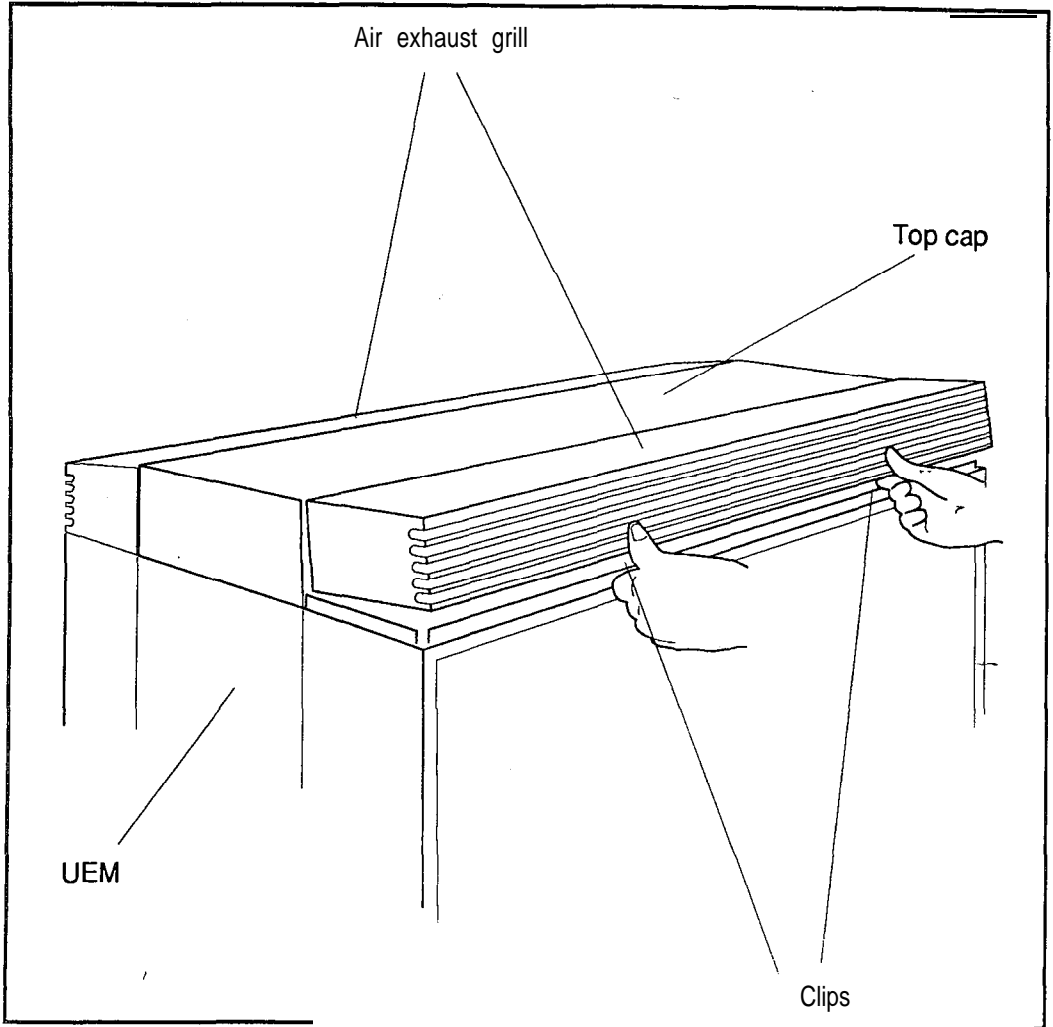

Figure 3-2
Top cap assembly

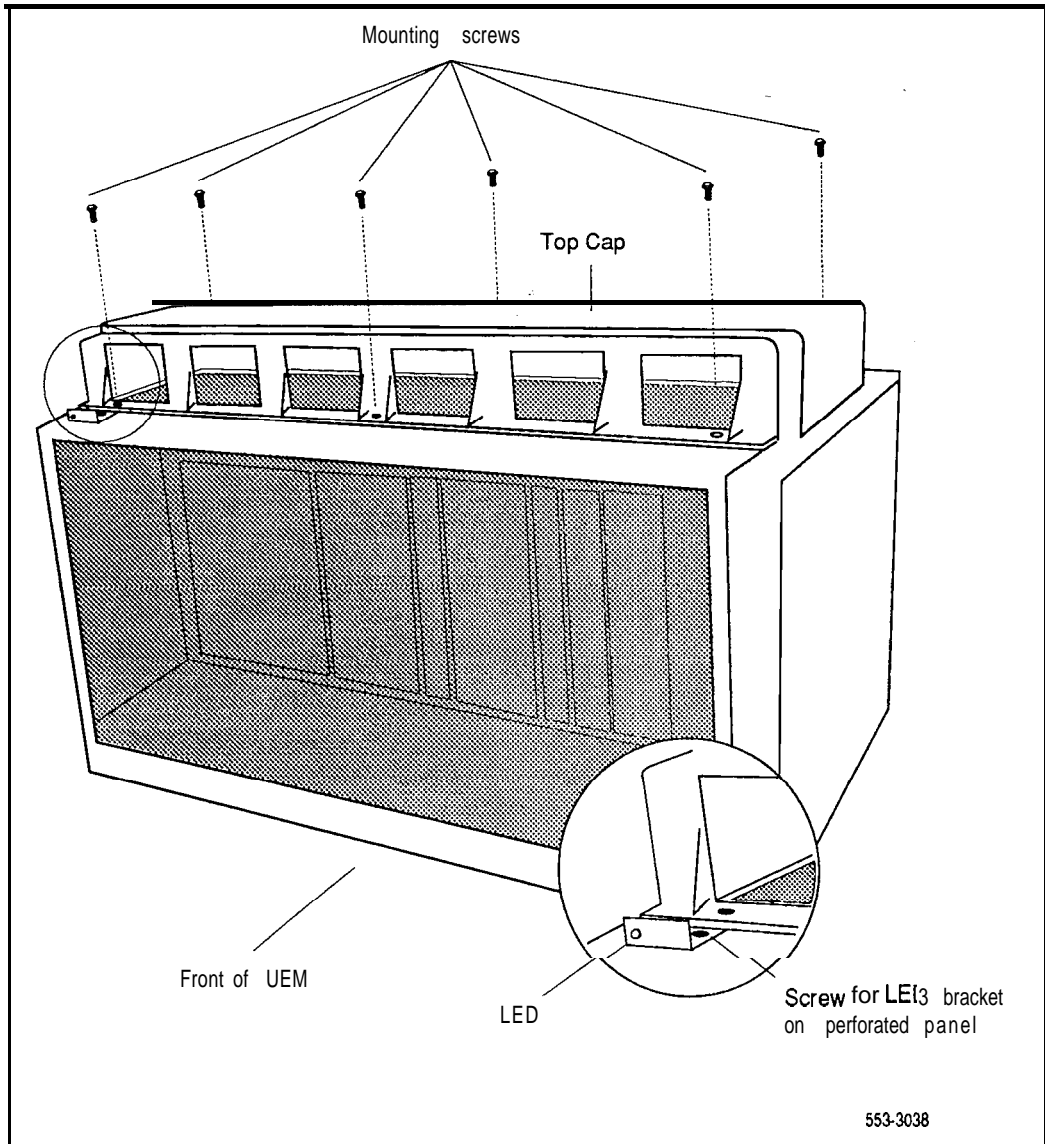
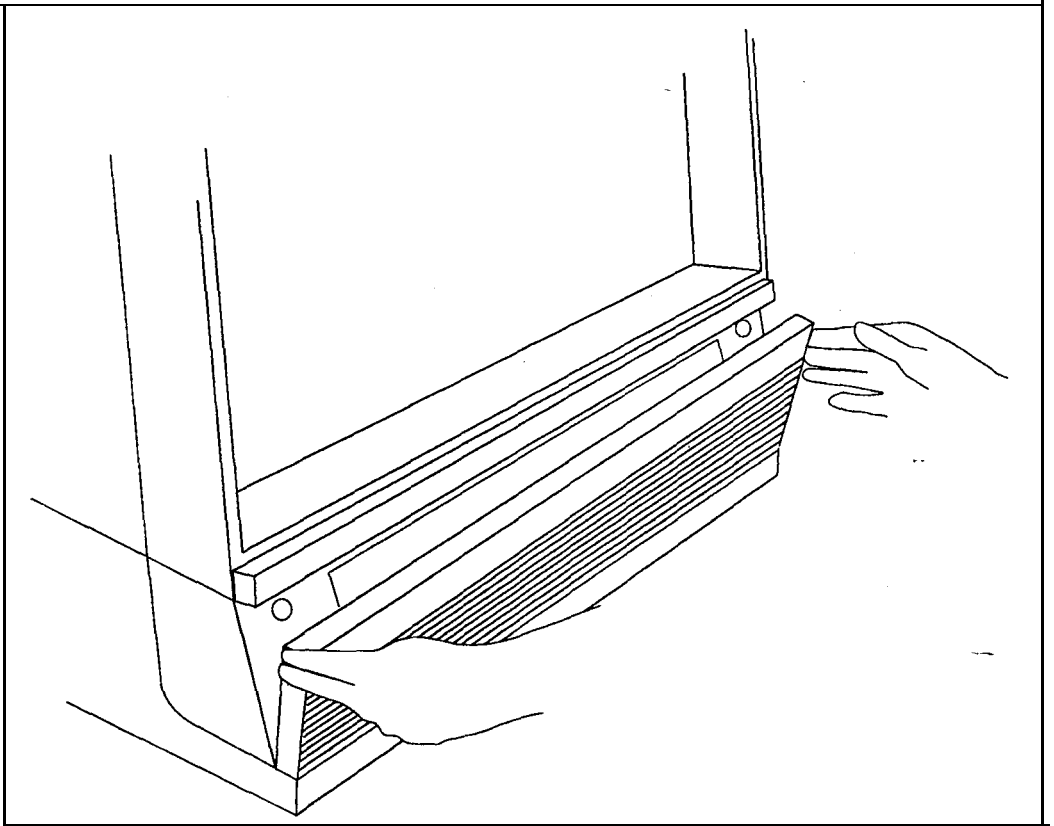

Figure 3-3
Pedestal air intake grill



3-8 Installing a Universal Equipment Module (UEM)

Figure 3-4
Main circuit breaker location (AC system)

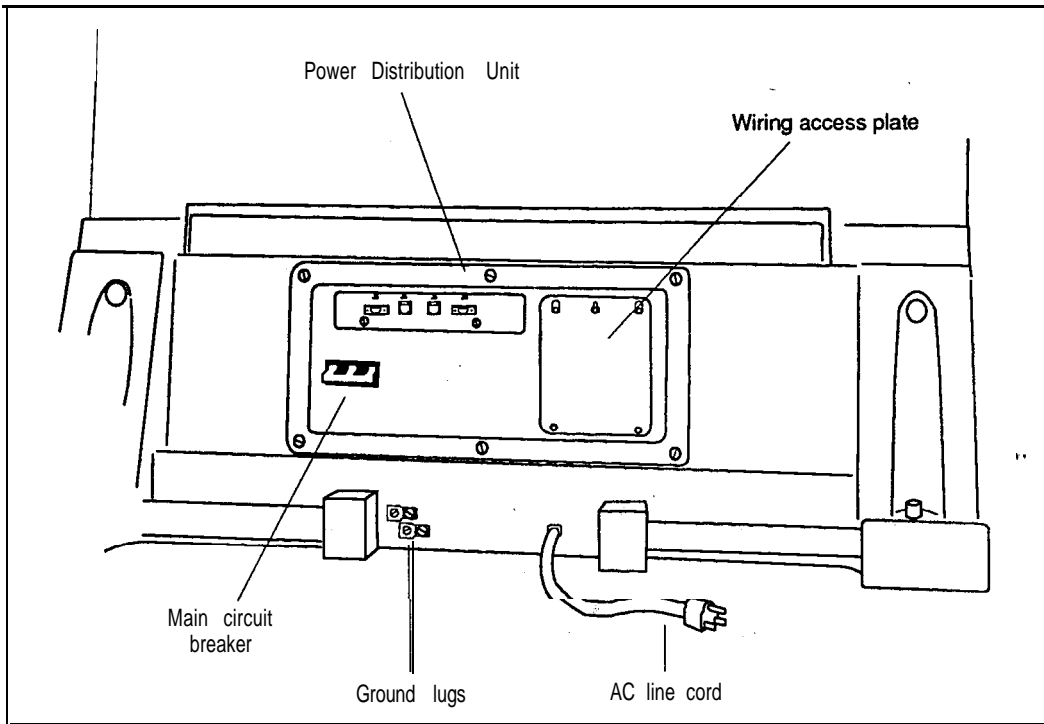
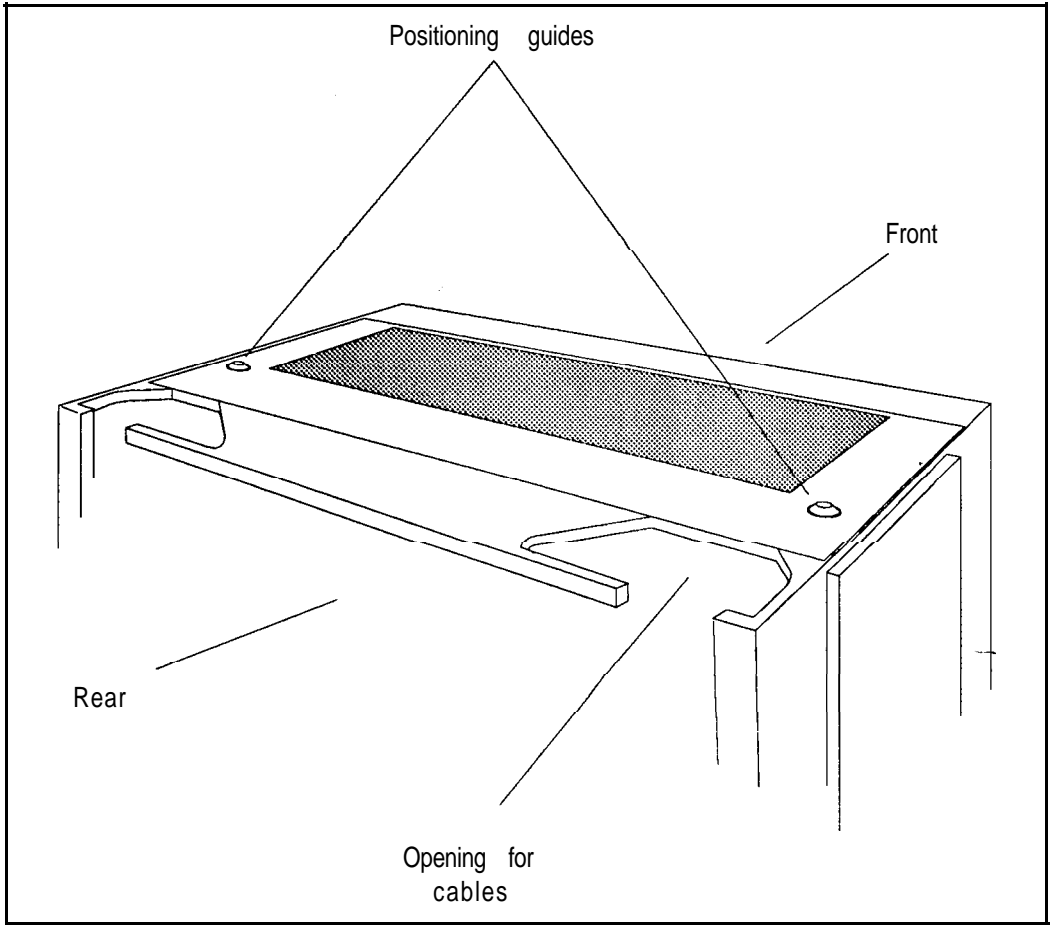

Figure 3-5
UEM positioning guides



3-10 Installing a Universal Equipment Module (UEM)

**Figure 3-6
UEM mounting bolts**

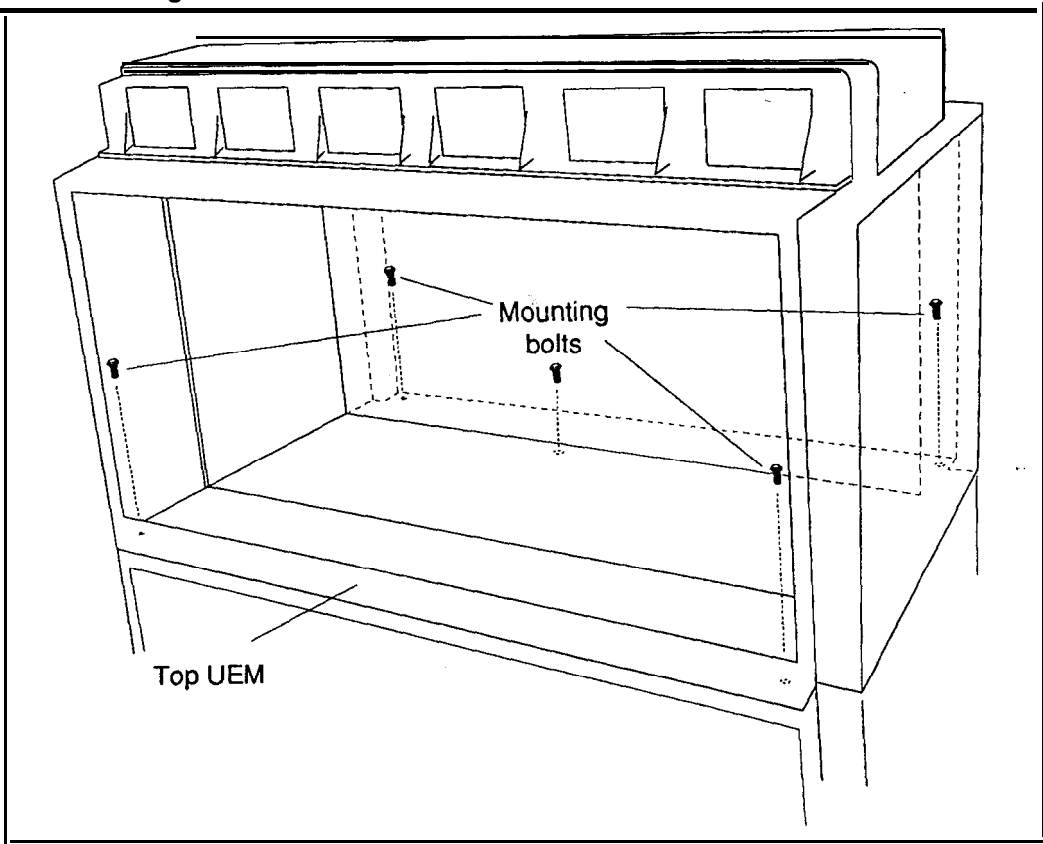

Figure 3-7
Power and System Monitor connections

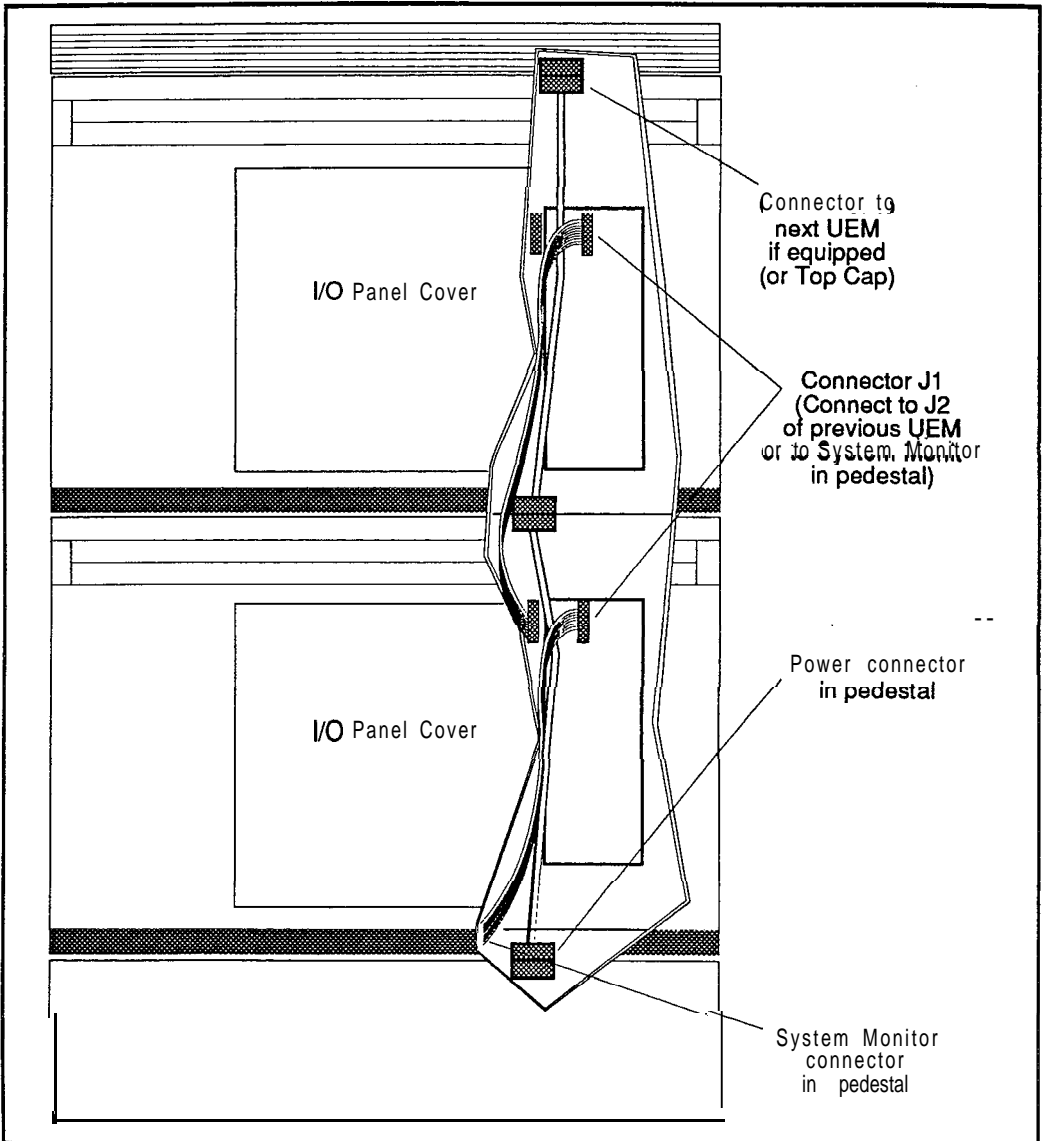

Figure 3-8
UEM to Top Cap power and system monitor cabling detail

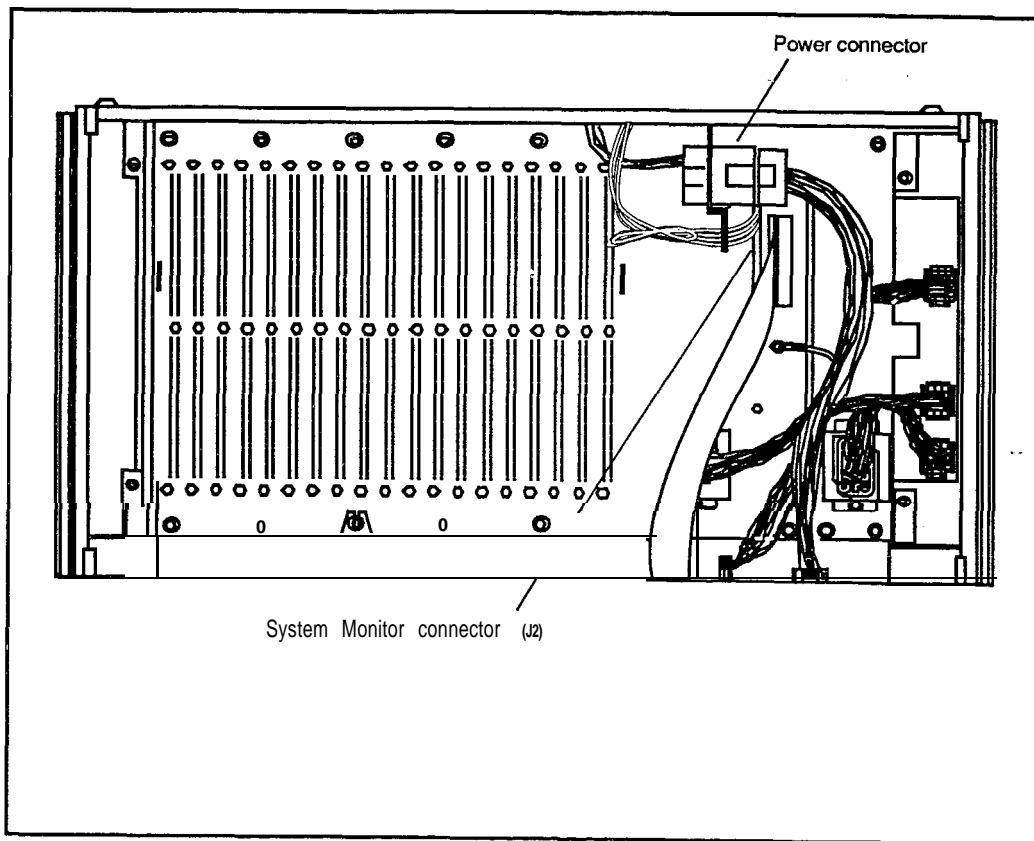

Figure 3-9
Power and System Monitor connectors in UEM

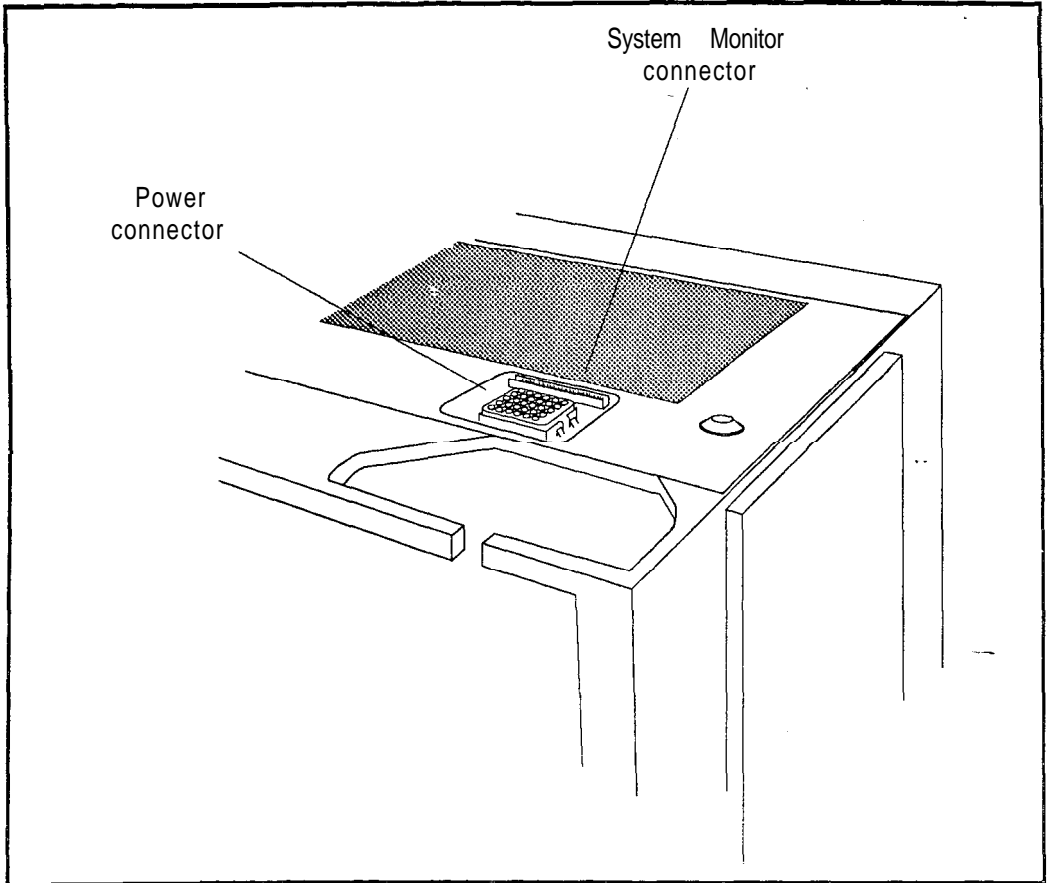

Figure 3-10
Power and System Monitor connectors in pedestal

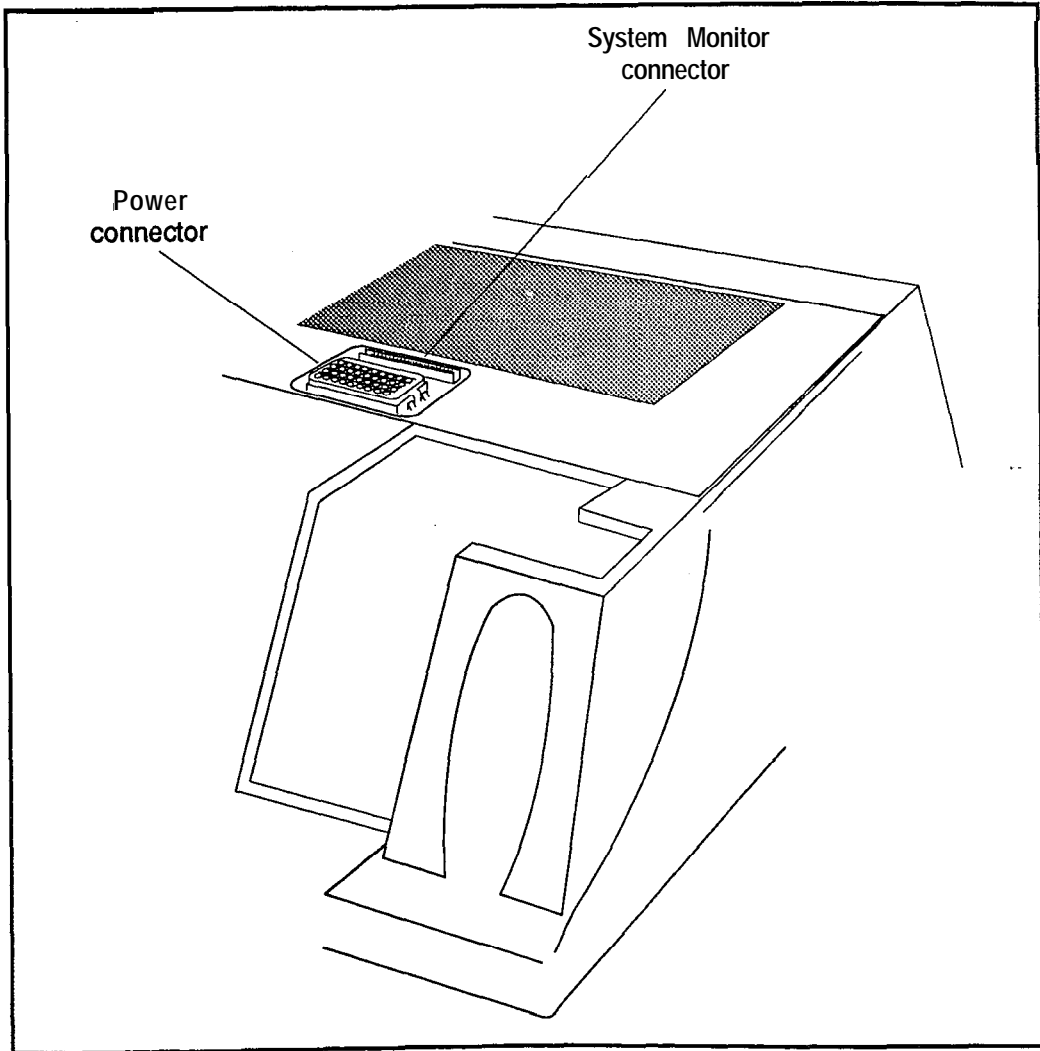

Figure 3-11
UEM to UEM power and System Monitor cabling detail

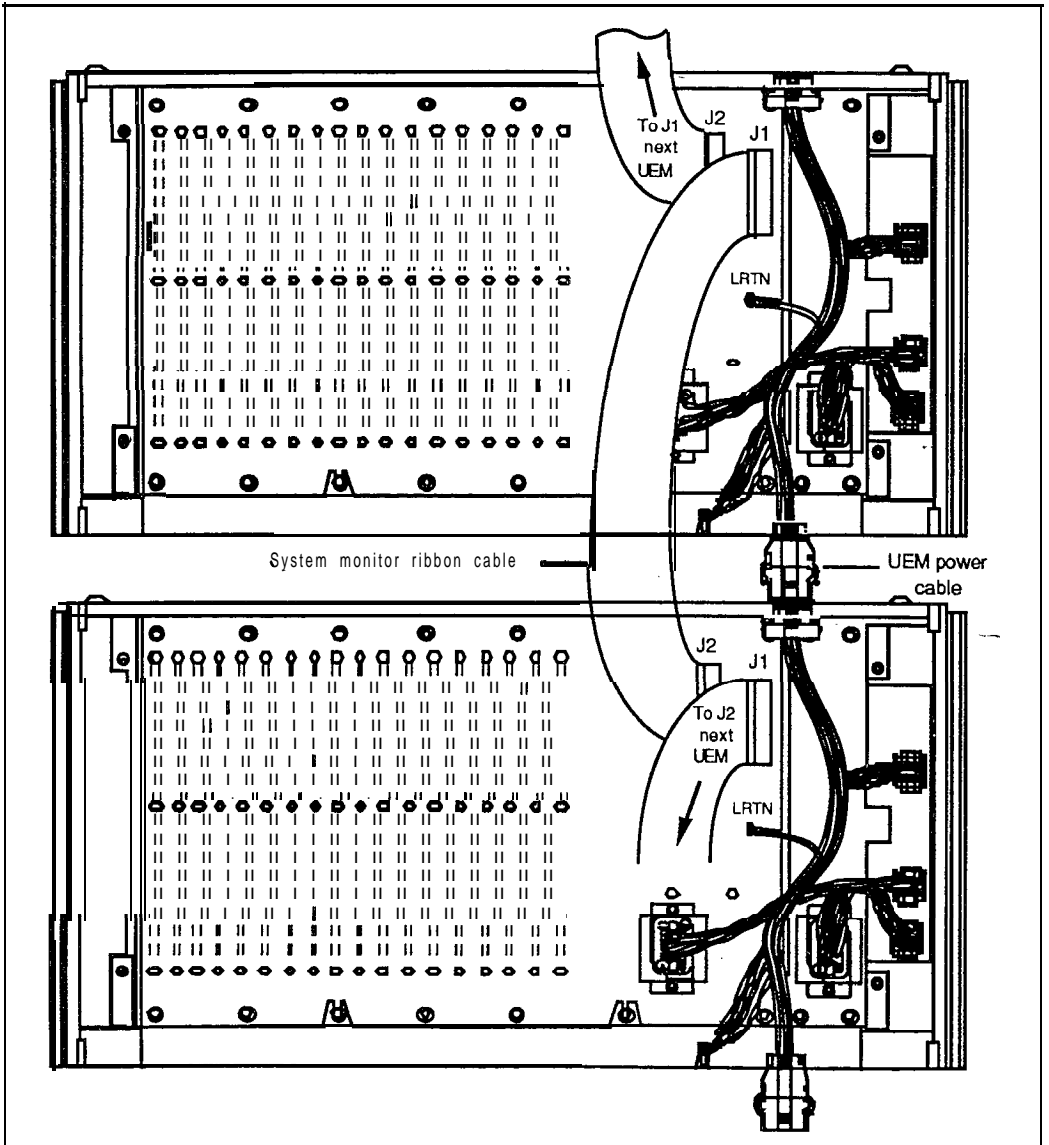
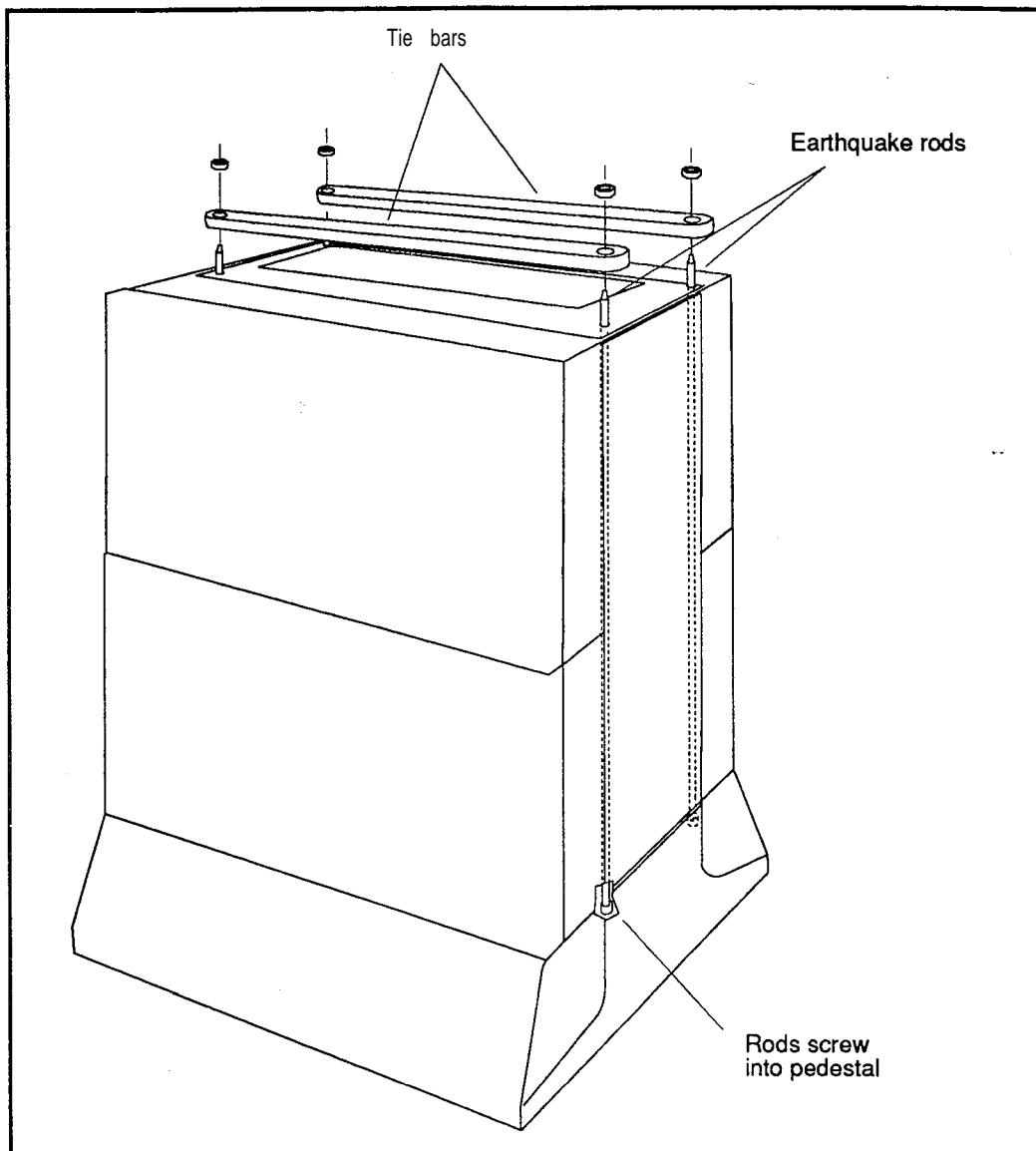

Figure 3-12
Earthquake bracing



Procedure 4: Positioning and levelling equipment

General information

Use this procedure to position and level equipment columns. If the column is to be bolted to the floor to comply with earthquake bracing requirements, make sure that the levelling feet have been removed from the pedestals and the four threaded mounting holes for the feet have been enlarged. The holes must be drilled to a size of 9/16 inches.

- 1 Consult the equipment room floor plan to determine designation and placement of equipment column(s).
- 2 Remove front and rear covers from each Universal Equipment Module (UEM). The covers are secured by two locking latches located at the top of each cover. See Figure 4-1.
- 3 Use a 5/16" socket wrench to remove the cosmetic panels of all UEMs in adjacent columns. The cosmetic panels are secured by four bolts located on each panel. See Figure 4-2.
- 4 Use a 5/16" socket wrench to remove the end panels of all UEMs in adjacent columns. The end panels are secured by four bolts located on the inside of the UEM (two at the front and two at the rear). See Figure 4-3.
- 5 Perform this step only if earthquake bracing is not installed and is required. See Figure 4-9.

Remove the six screws securing the top cap to the column and remove the top cap.

Install two earthquake rods on each side of the column as shown in Figure 4-9. It may be necessary to temporarily remove any remaining end panels from the UEMs to position the rods. The slightly flattened end of the rods should be positioned at the top of the column to allow tightening of the rod with a wrench or pliers.

Tighten the rods in the threaded holes on the top of the pedestal.

Install the two tie bars across the top of the column. Secure the tie bars to the earthquake rods with the hex nuts provided.

Reinstall the top cap.

- 6 If the pedestal is to be bolted to the floor (part of earthquake bracing requirements), remove the column levelling feet. See Figure 4-8.

Note: The feet mounting holes must be enlarged to a size of **9/16"**.

Position each column in its final location and secure with bolts to the previously installed bolt anchors in the floor.

Install the washers, **bolts** and shims (if required to level the column) as shown in Figure 4-10.

Make sure that each column is properly **levelled** and aligned. Columns may have to be adjusted when installing expansion kits in the following steps, if they are required.

- 7 Position an expansion kit on each UEM in the first column and **secure** using the screws and spacers provided.

Figure 4-4 illustrates a multiple column SL-1 system equipped with **NT8D49** Expansion kits.

Figures 4-5 through 4-7 illustrate the correct positioning and installation of the expansion kit.

- 8 Place the next column in its final position.
- 9 Secure each UEM in this column with an expansion assembly to the UEM next to it. Use a **5/16"** screwdriver to adjust the levelling feet to raise or lower the column and line up the screw holes. See Figure 4-8. If the column is bolted to the floor (for earthquake bracing), adjust the levelling by adding or removing shims as required under the column. See Figure 4-10.

CAUTION

DO NOT attempt to adjust the horizontal position of a column by tightening the expansion assembly screws. Tightening the screws with the columns **too** far apart will warp the expansion assembly. Position the equipment columns before tightening the expansion assembly screws.

- 10 Repeat steps 6 and 7 for each remaining equipment column.
- 11 Replace the circuit breaker cosmetic panel in each UEM. Leave the cosmetic panel on the right side of each UEM off to facilitate cable routing. Remember to replace these cosmetic panels when all cabling is completed.
- 12 Use a **5/16"** screwdriver to adjust the column levelling feet to level and secure all equipment columns. See Figure 4-8.

Figure 4-1
UEM cover with lock latches

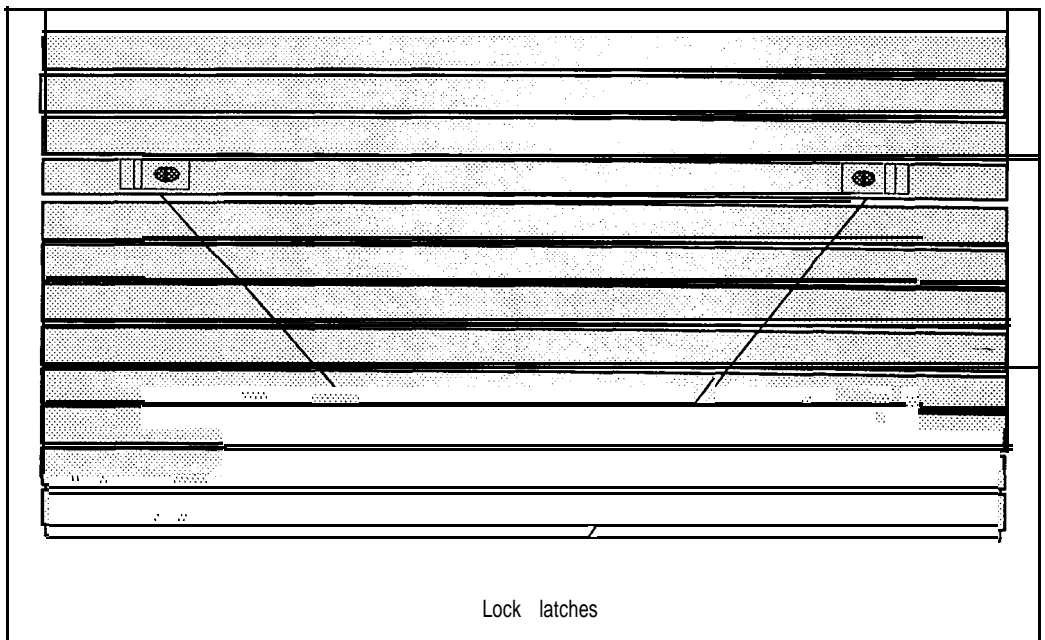

Figure 4-2
Cosmetic panel removal

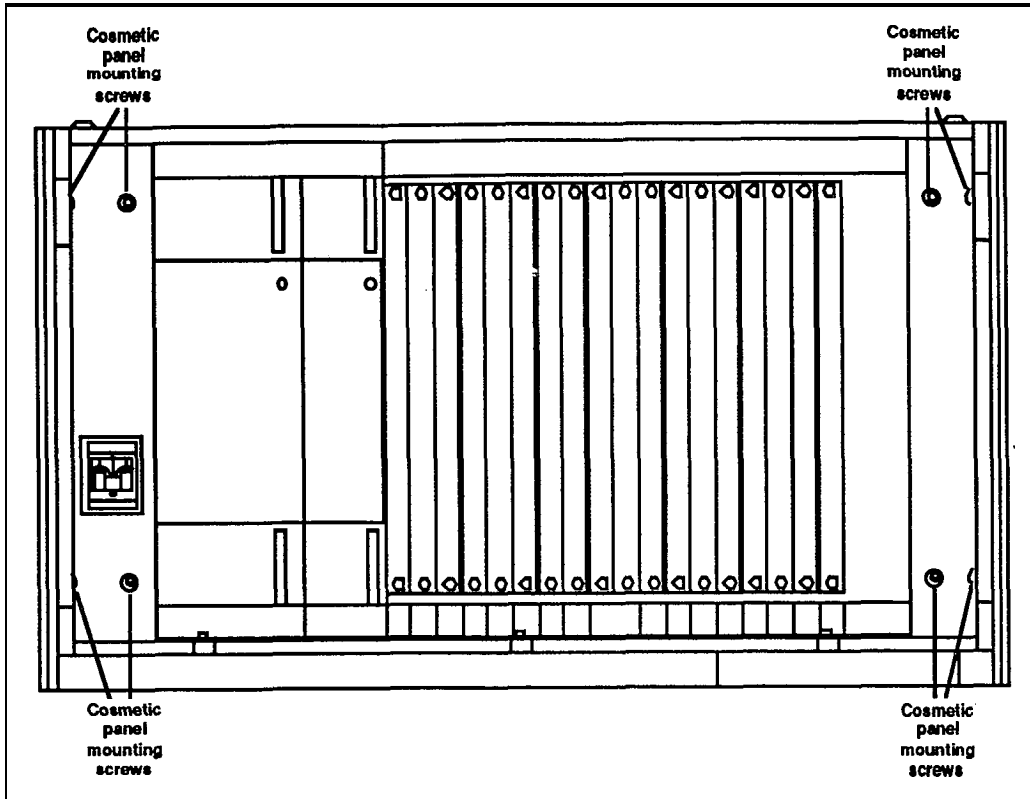

Figure 4-3
End panel removal

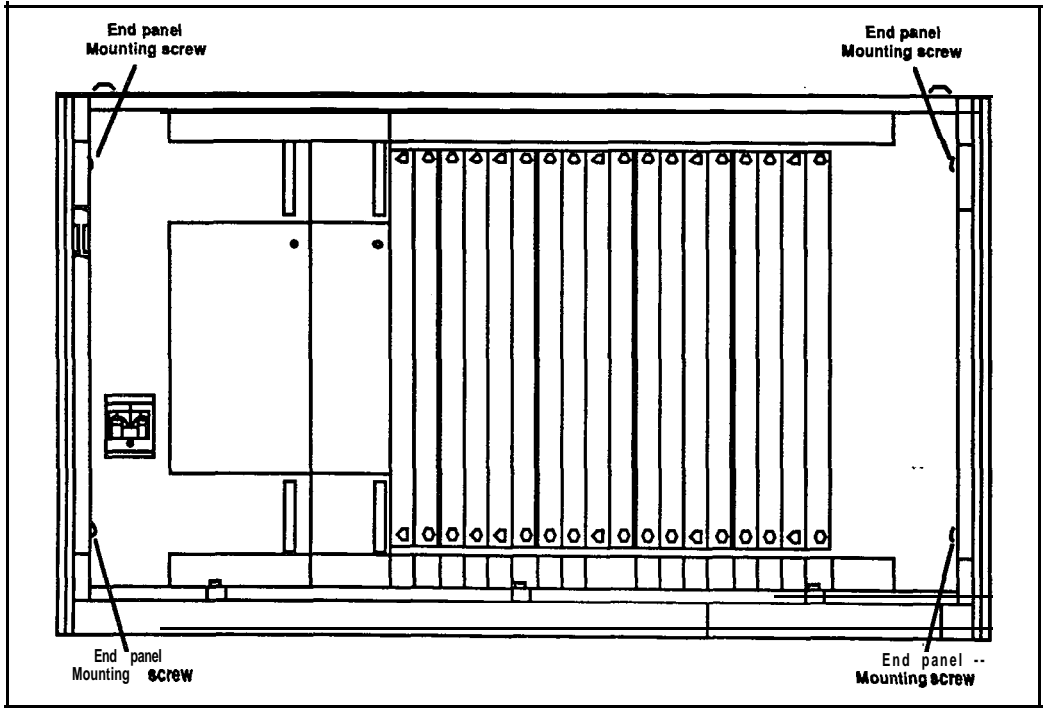

Figure 4-4
Multiple column system using **NT8D49** expansion kits

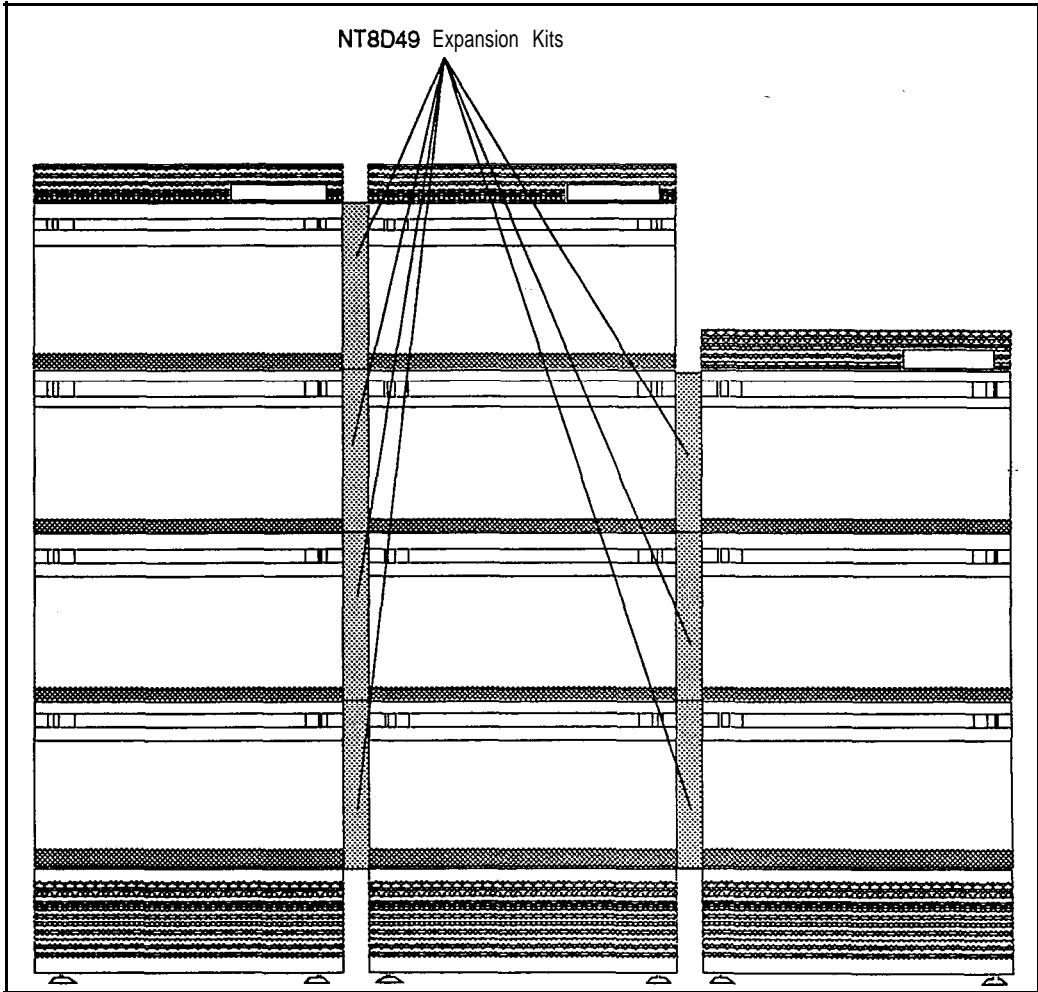

Figure 4-5
NT8D49 Expansion kit assembly -front cutaway view

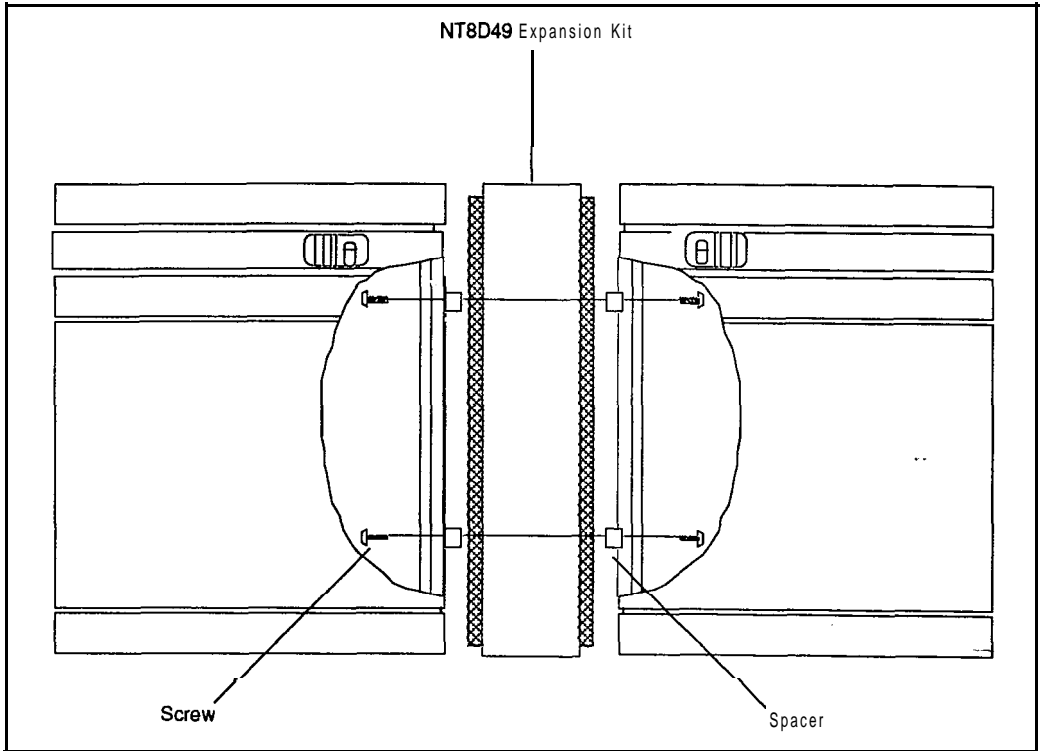

Figure 4-6
NT8D49 Expansion kit assembly — side view

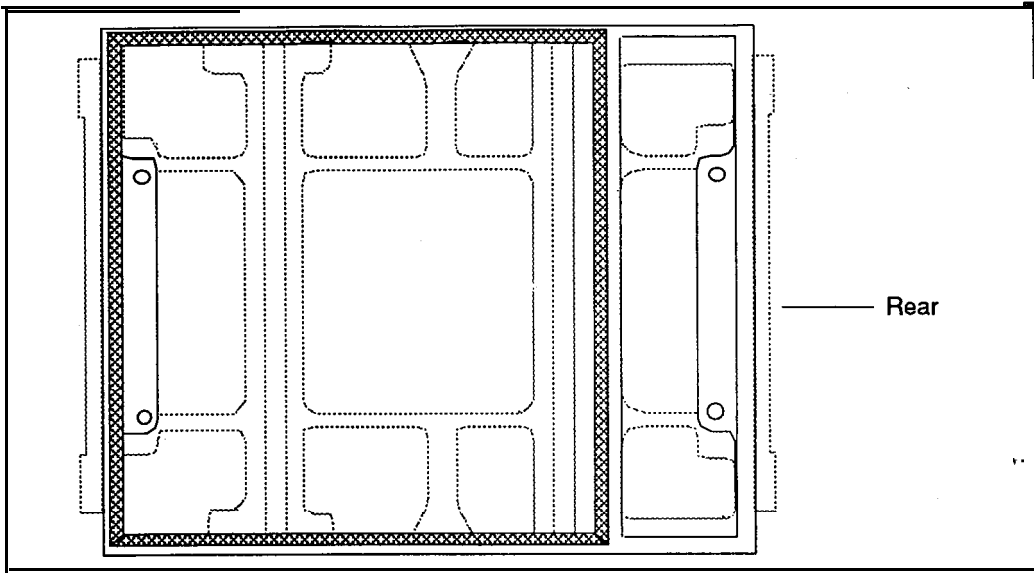
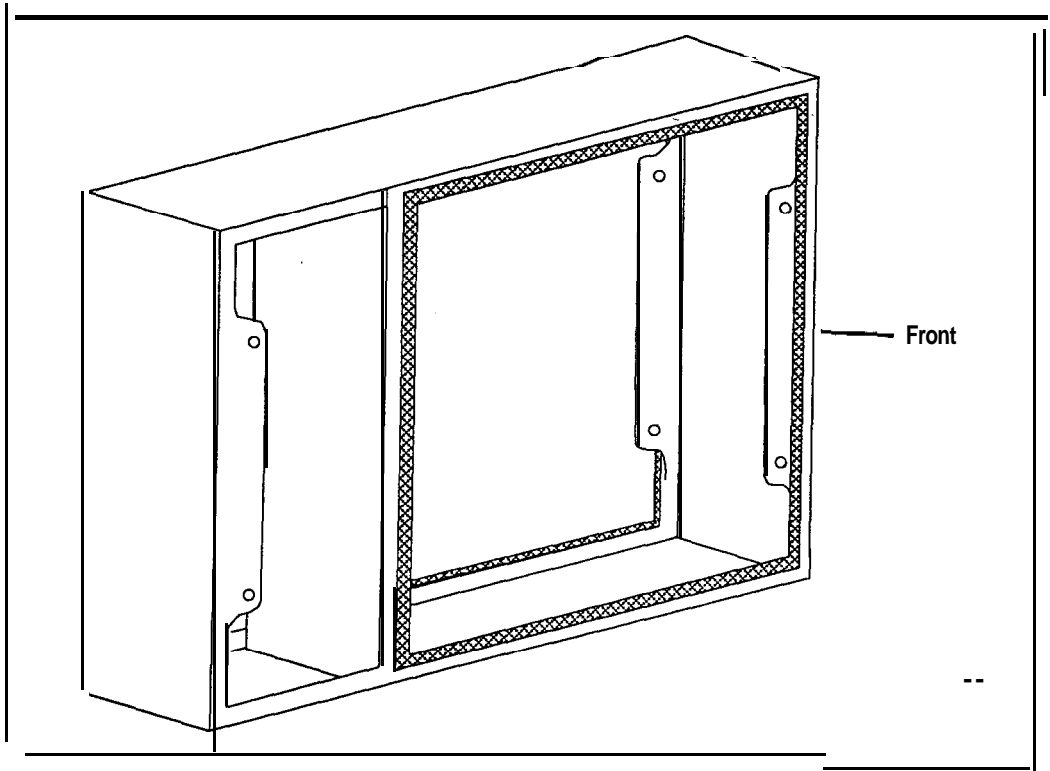

Figure 4-7
NT8D49 Expansion kit assembly — perspective view.



4-10 Positioning and levelling equipment

Figure 4-8
Levelling foot adjustment

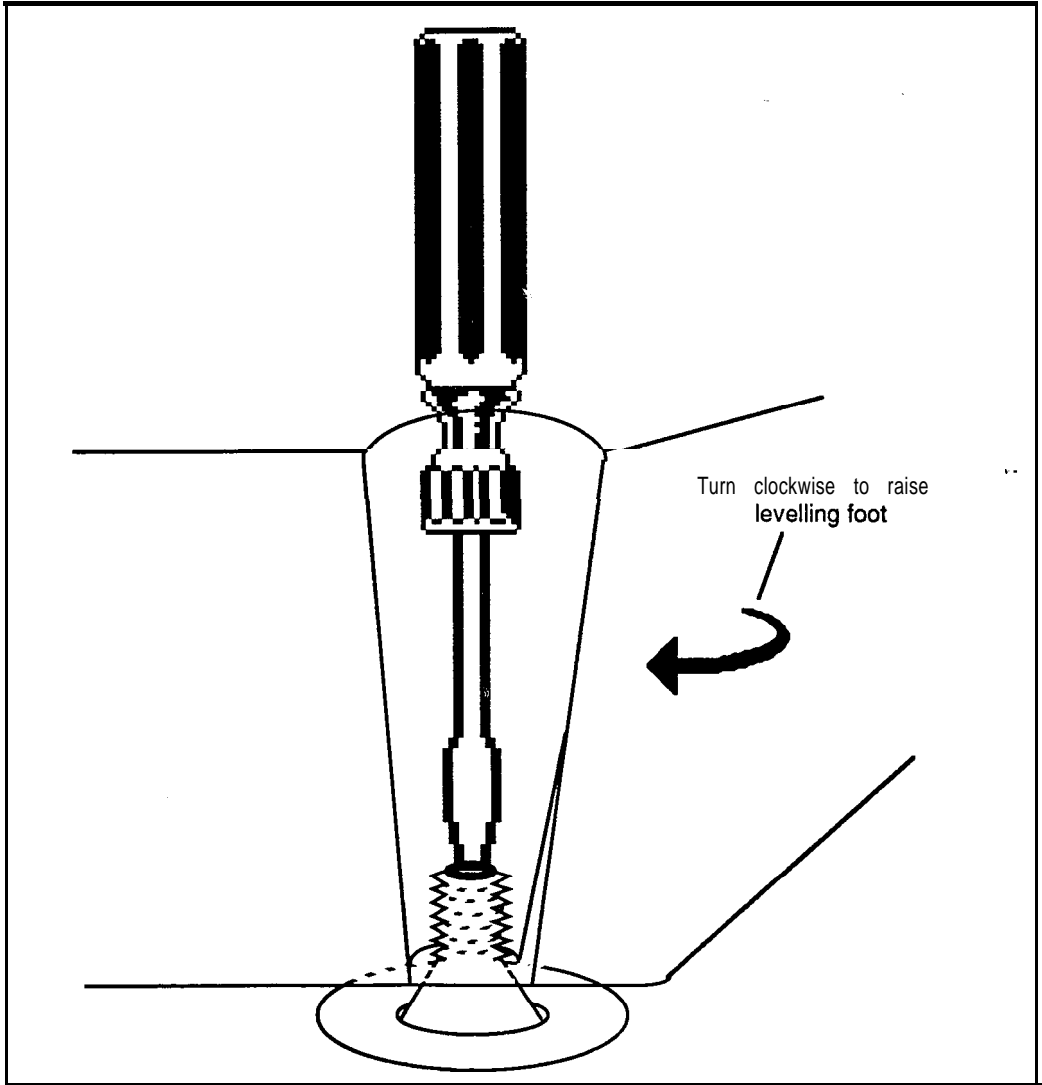
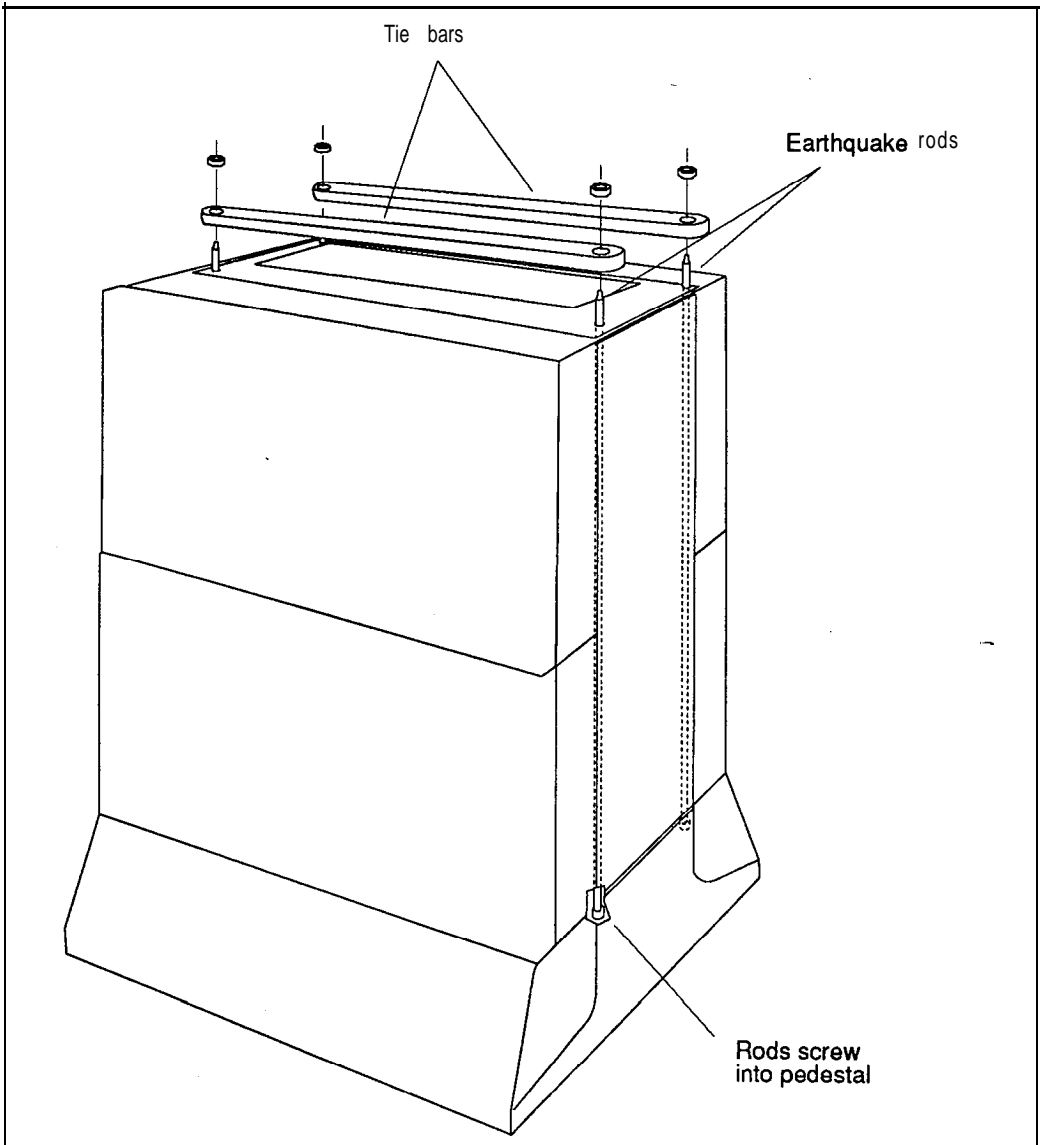
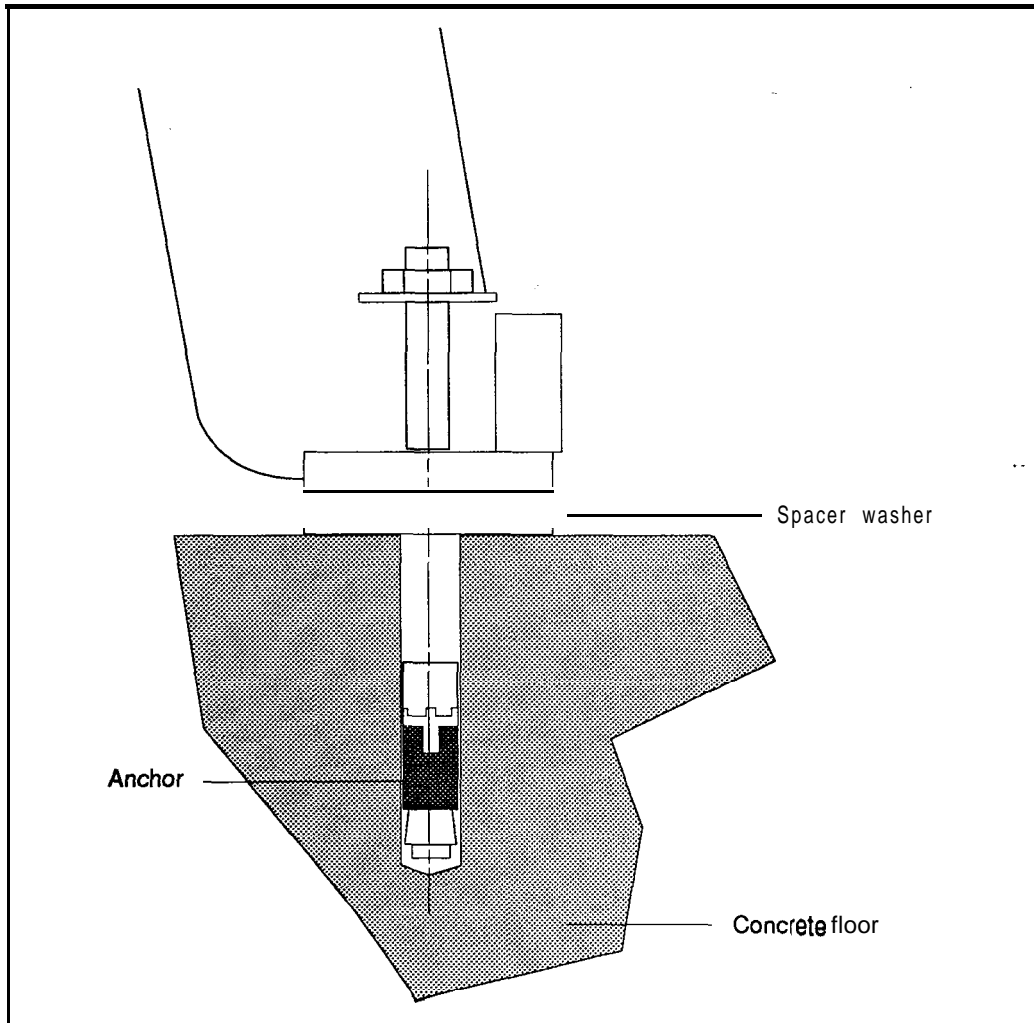

Figure 4-9
Earthquake bracing installation



4-12 Positioning and levelling equipment

Figure 4-10
Anchor bolt installation



Procedure 5: Installing an NT8D63AA Overhead Cable Tray Kit

General information

Use this procedure to install an NT8D63AA cable tray kit. The overhead cable tray kit, which is designed to support cable trays or ladder racks, mounts on the top of columns of UEMs. Each kit consists of two cable rack support brackets, front and rear exhaust grills designed to be used with the brackets and associated hardware needed to secure the kit to the top of a column.

Installation procedure

- 1 Remove the existing front and rear exhaust grills (if equipped) from the top of the column onto which the overhead cable tray kit is to be installed.
- 2 Mount a support bracket at the front and rear of the UEM. Secure each support to the threaded holes in the top of the UEM with two bolts as shown in Figure 5-1.
- 3 Install the front and rear air exhaust grills provided with the kit. These grills have cutouts for vertical exit of cables to the cable rack.
- 4 Place the cable rack on top of the supporting brackets and fasten it to the supports with J bolts, as illustrated in Figure 5-1.

5-2 Installing an overhead cable rack

Figure 5-1
Overhead cable tray

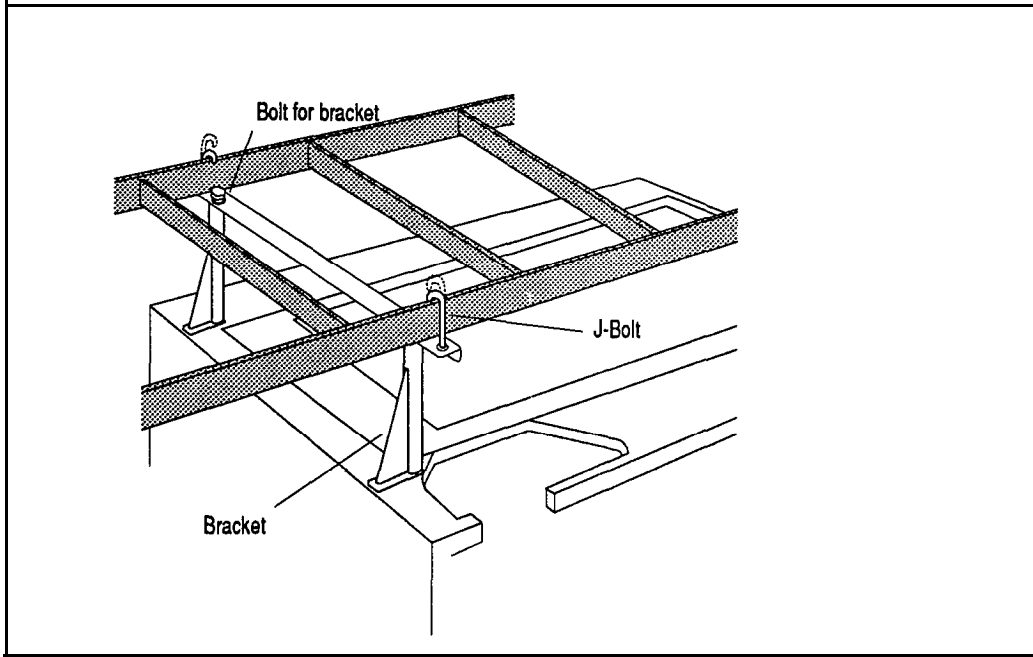

Procedure 6: Mounting NT6D52 rectifiers

General information

Use this procedure to install NT6D52 rectifiers in an NT7D12AA rectifier rack assembly.

The NT6D52 enclosed rectifier consists of a QRF12 rectifier enclosed in a frame which provides EMI suppression, and which can be mounted in an NT7D12AA rectifier rack assembly. Up to three rectifiers may be mounted in the rectifier rack. See Figure 6-1.

Installation procedure

- 1 If not already installed, position the NT7D12AA rectifier rack in its final location. Install bolts in the four holes located at the base of the rack to secure it to the floor.
- 2 If not already installed, mount an NT7D1201 baffle assembly on the NT7D12AA rectifier rack directly below the position to be occupied by the rectifier. See Figure 6-1. Secure the baffle assembly to the rack with the six mounting screws provided. See Figure 6-2. --

Note: To ensure proper weight distribution, rectifiers should be installed starting at the bottom of the rectifier rack.

- 3 If the rectifier is not already mounted, mount the rectifier directly above the baffle assembly. The baffle assembly serves as a support for the rectifier. Secure the rectifier to the rack with the eight mounting screws and to the baffle assembly with the two self-tapping screws provided. See Figure 6-3.
- 4 Remove the rear access panel from the rectifier. See Figure 6-4.
- 5 If the AC line cord is not installed, install and connect it to the rear of the rectifier as shown in Figure 6-4. Do not connect it to the commercial AC power supply outlet.
- 6 Install the 1 1/4" conduit fitting as illustrated in Figure 6-4.

- 7 Neatly secure the AC line cord and other external wiring to the rectifier rack with plastic cable ties.
- 8 Replace the rear access plate on the rectifier if work operations in this rectifier are completed for the present. Leave the rear access plate off if the connections from the rectifier to the **QBL15** are to be made at this time.
- 9 Check the **220V/110V** switch (switch SW1 located to the left of the AC BRKR switch on the front of the rectifier) and make sure that it is set to the correct voltage. The switch is locked in position by a bracket secured with two screws. It should be set to correspond to the commercial AC power supply provided for the rectifier.

Figure 6-1

NT6D52 enclosed rectifiers and NT7D12 rectifier rack assembly

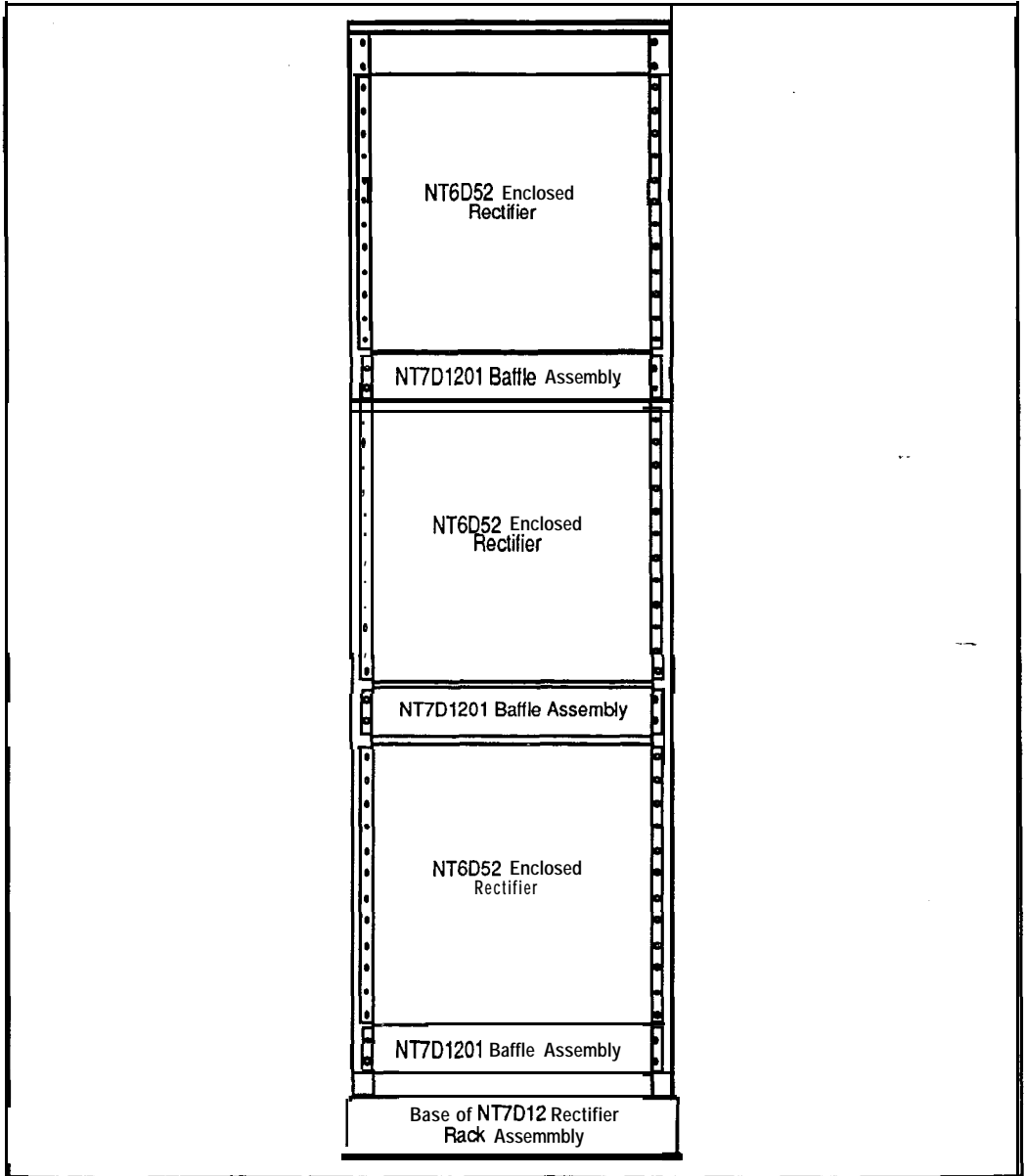

Figure 6-2
NT7D1201 baffle assembly mounted in rack

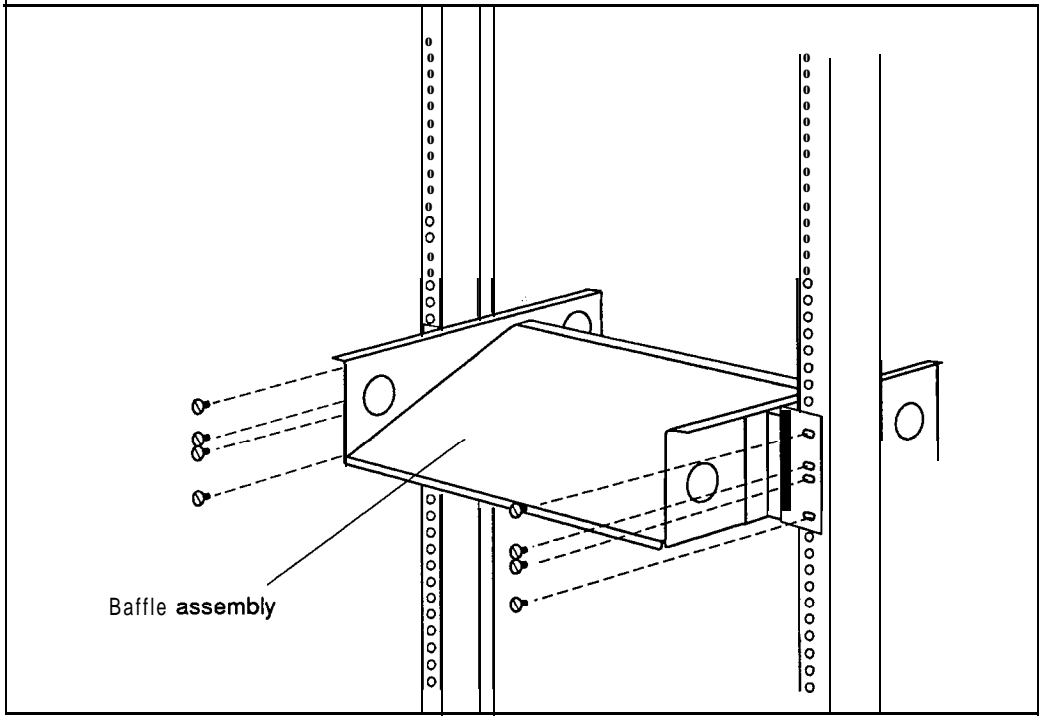
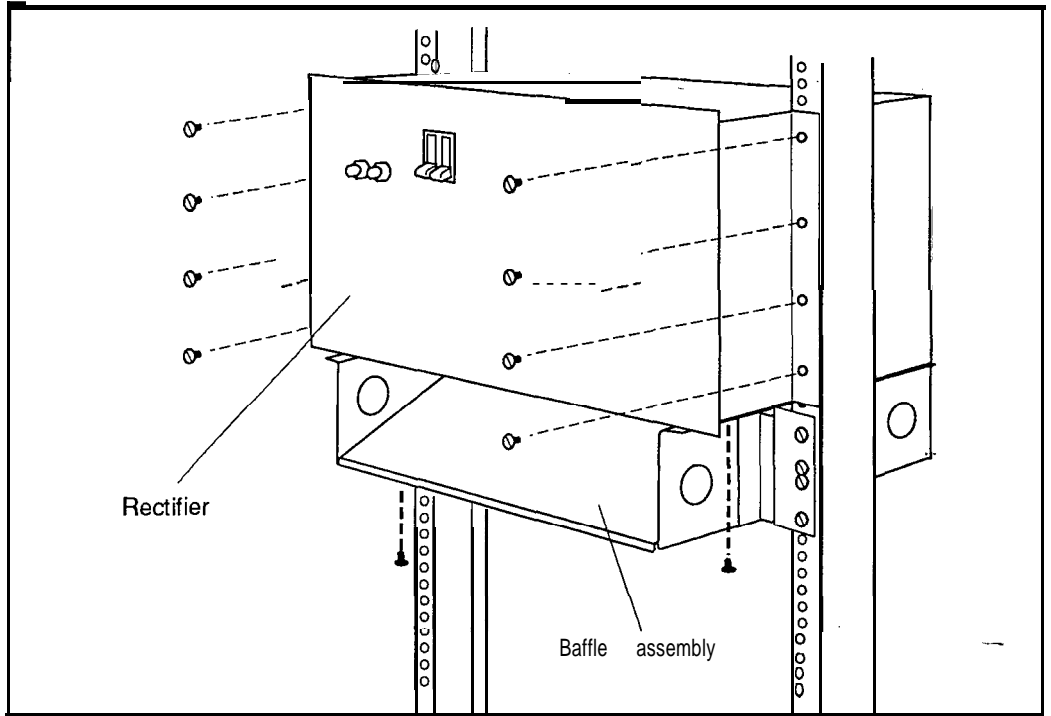
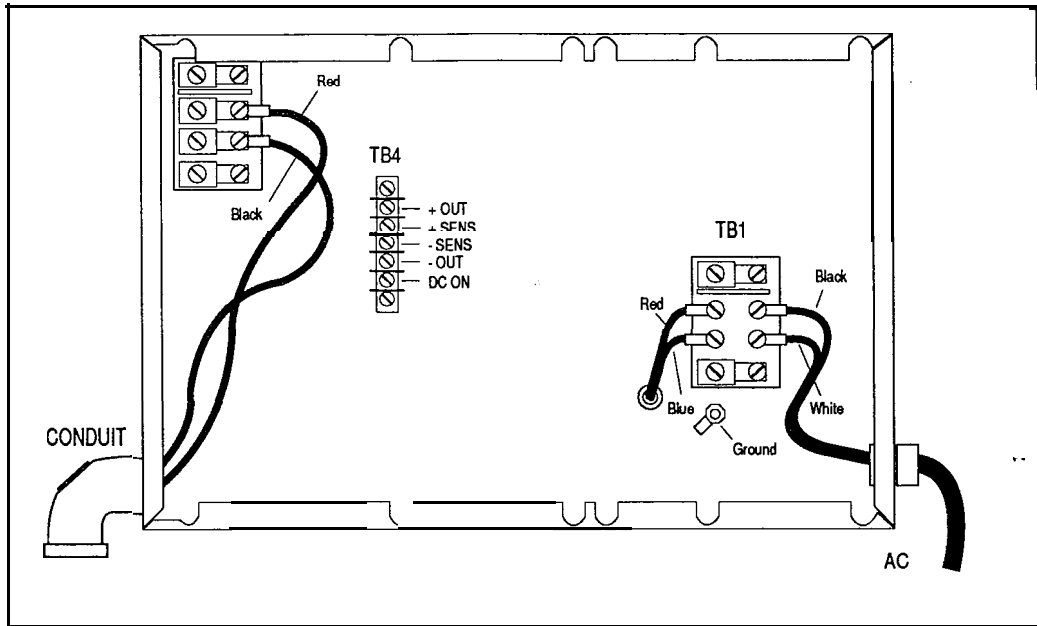

Figure 6-3
NT6D52 enclosed rectifier mounted in rack



6-6 Mounting NT6D52 rectifiers

Figure 6-4
Rear view of NT6D52 enclosed rectifier



Procedure 7: Installing a battery distribution box and connecting to batteries

General information

Use this procedure to install and connect QBL12 and **QBL15** battery distribution boxes to the battery string and to add a second QBL 15 to an existing system.

Installing a **QBL12** or **QBL15** battery distribution box

- 1 Unpack the battery distribution box and inspect the unit and the meters for damage.
- 2 Mount the battery distribution box securely on a wall or other suitable location. The unit should be mounted approximately 4 ft (1220 mm) from the floor. It should be mounted close enough to the batteries to allow a voltage drop of not more than .25 V (.50 V on the loop) on the I/O AWG wire between it and the batteries. See *Power engineering* (553-3001-152) for calculating conductor length.

Adding a second **QBL15**

- 1 Unpack the **QBL15** battery distribution box and inspect the unit and the meters for damage.

<p style="text-align: center;">CAUTION</p> <p>The QBL15 battery distribution box weighs approximately 50 lb (25 kg).</p>
--

- 2 Mount the second **QBL15** battery distribution box on a wall or other suitable location. The box should be mounted approximately 4 ft (1220 mm) from the floor. The box should be mounted within approximately 4 ft (1220 mm) of the first **QBL15**
- 3 Refer to Figure 7-2 while performing the following steps.

- 4 Remove the cover plate that covers the main circuit breaker (or main fuse).
- 5 Install and connect a 4 AWG (preferably red) wire between the initially installed **QBL15** and the second **QBL15**. The connection point on each unit is a **1/4-20** stud located at the top of the large **heatsink** (there are already 4 wires connected to this stud). Crimp a ring lug on each end of the wire, or use a compression fitting such as the type provided on the positive bus, prior to installation.
- 6 Install and connect a 4 AWG (preferably black) wire between the initially installed **QBL15** and the second **QBL15**. The connection point on each unit is a compression fitting on the positive bus (+VE BUS).
- 7 Do not set the main circuit breaker of this second **QBL15** battery distribution box to ON (or do not reinsert the main fuse in the box).
- 8 Replace the cover plate that covers the main circuit breaker (or main fuse). Tag this second circuit breaker "CIRCUIT BREAKER IS NON-FUNCTIONAL".

Connecting a **QBL12**

- 1 Open the front cover of the unit.
- 2 Install and connect a 1/0 AWG (preferably black) wire between the positive terminal of the battery string and system ground source (typically to a ground window connected to the ground bus in the AC power service panel). See Figure 7-1.
- 3 **Install** and connect a 1/0 AWG (preferably red) wire between the negative terminal of the battery string and the **-48 V** input terminal in the **QBL12** battery distribution box. See Figure 7-1.
- 4 Connect a 16 AWG wire between the positive terminal of the battery and connector **TB3-1 (+SENSE)** of the **QBL12**. Smaller gauge wire may be used if it does not provide more than 2.5 Ohms of resistance across its entire length.
- 5 Connect a 16 AWG wire between the negative terminal of the battery and connector **TB3-2 (-SENSE)** of the **QBL12**. Smaller gauge wire may be used if it does not provide more than 2.5 Ohms of resistance across its entire length.
- 6 Close the cover of the **QBL12** if work operations are completed.

Figure 7-1
QBL12 and battery connections

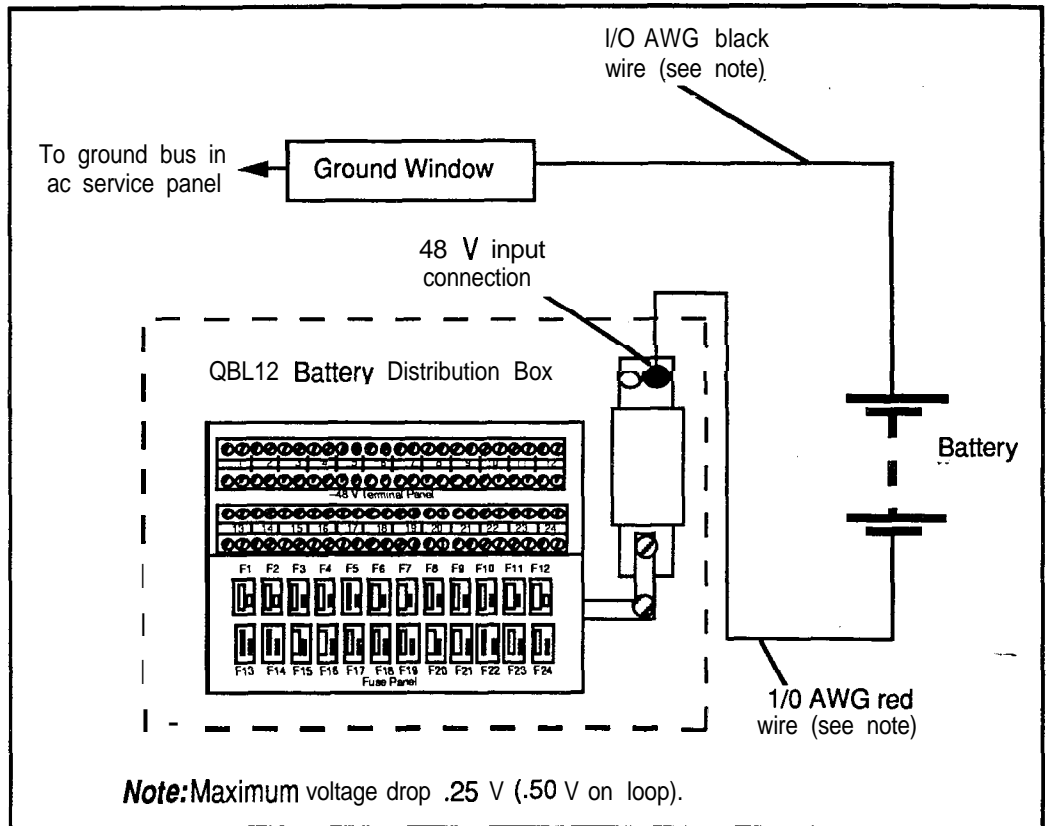

Connecting a QBL15

- 1** Open the front cover of the unit (when two **QBL15** units are installed, perform this procedure on the unit with the functional circuit breaker only). Set the main circuit breaker in the unit to **OFF**, or if it is equipped with a main fuse (**CRS200**) instead of a circuit breaker, remove the fuse. See Figure 7-2.
- 2** Install and connect a 1/0 AWG (preferably red) wire between the negative terminal of the battery string and the negative input at the top of the circuit breaker or fuse in the **QBL15** battery distribution box. See Figure 7-2.
- 3** Install and connect a second 1/0 AWG (preferably black) wire between the positive terminal of the battery string and the positive bus (+VE BUS) in the **QBL15** battery distribution box. See Figure 7-2.
- 4** Close the cover of the QBL 15 if work operations are completed.

Figure 7-2
QBL15 and battery connections

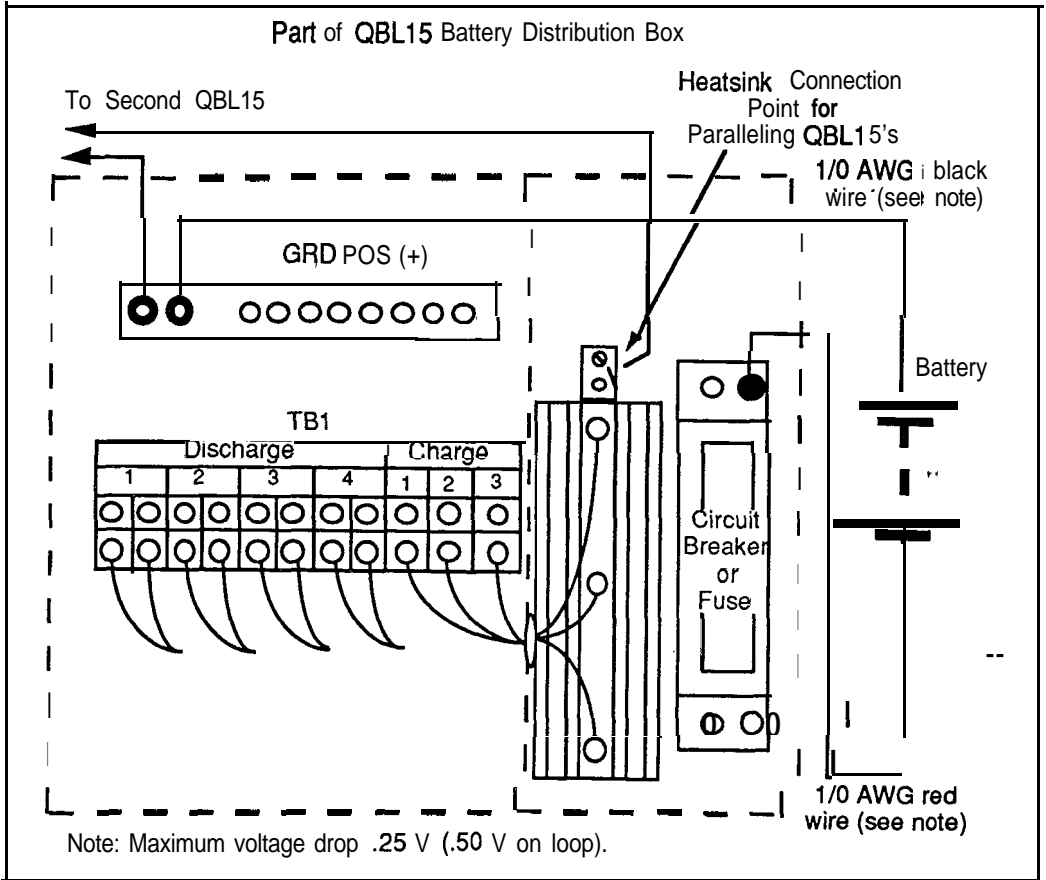

7-6 Installing a battery distribution box and connecting to batteries



Procedure 8: Installing and testing ground wiring

General information

Use this procedure to install and test personal hazard and logic return ground wiring for an SL-1 system.

WARNING

Proper grounding is extremely important!

Failure to complete grounding tests could result in a system that is unsafe for personnel using the equipment, not protected from lightning or power surges, and subject to service interruptions. Refer to *Installation planning* (553-3001-120) for a complete description of approved ground sources and methods. Insulated ground wire must be used for system grounding.

Installing and testing personal hazard ground on AC systems

- 1 Make sure the AC line cord is unplugged.
- 2 Remove rear pedestal cover of each equipment column.
- 3 For each column, measure the resistance between the ground pin on the AC line cord plug and the ground lug on the rear of the pedestal for that column. See Figure 8-1. The resistance should be 0 ohms. If the resistance is greater than 0 ohms; check the AC power cord connections.
- 4 On a multi-column system, connect a #6 AWG wire between the ground source (typically the ground bus in the AC power service panel) and the logic return equalizer. For a single column system, connect the #6 AWG wire directly to the ground lug at the rear of the pedestal.
- 5 Place a warning tag (**WARNING — TELEPHONE SYSTEM GROUND CONNECTION — DO NOT DISCONNECT**) on the connection at the ground source.
- 6 On a multi-column system, connect a #6 AWG wire between the LRE and the ground lug on the rear of the nearest equipment column.

- 7 On a multi-column system, connect the ground lugs of each pedestal together in a daisy-chain arrangement using #6 AWG wire. See Figure 8-2.
- 8 For each column, measure the resistance between the ground pin on the AC line cord plug and the ground terminal on the AC power outlet. The resistance should be 0 ohms. If the resistance is greater than .5 ohms, check the AC power outlet ground and personal hazard ground connections.

Installing and testing personal hazard ground on systems equipped with NT6D52 rectifiers

- 1 Make sure the AC line to each rectifier is unplugged.
- 2 For each rectifier, measure the resistance between the ground pin on the AC line cord plug and the ground lug on the rectifier rack assembly. The resistance should be 0 ohms. If the resistance is greater than 0 ohms, check the AC power cord connections.
- 3 Connect a #6 AWG wire between the ground source (typically the ground bus in the AC power service panel) and the positive VE bus of the QBL15.
- 4 Place a warning tag (**WARNING — TELEPHONE SYSTEM GROUND CONNECTION -DO NOT DISCONNECT**) on the connection at the ground source.
- 5 Connect a #6 AWG wire between the positive VE bus of the QBL15 and the ground lug of the nearest equipment column.
- 6 Connect the ground lugs of each pedestal and each rectifier rack together in a daisy-chain arrangement using #6 AWG wire (see Figure S-2). Alternately, the ground wire to the rectifier rack may be run directly to the ground source.
- 7 For each rectifier, measure the resistance between the ground pin on the AC line cord plug and the ground terminal on the AC power outlet. The resistance should be 0 ohms. If the resistance is greater than .5 ohms, check the AC power outlet ground and personal hazard ground connections.

Installing and testing personal hazard ground on systems equipped with a QBL12 battery distribution box

- 1 If connected, disconnect the -48 V dc power from each pedestal by removing the associated 30 A fuse from the power supply panel in the QBL12.
- 2 Connect a #6 AWG wire between the ground source (typically the ground bus in the AC power service panel) and the ground lug on the rear of the nearest equipment column.
- 3 Place a warning tag (WARNING — TELEPHONE SYSTEM GROUND CONNECTION -DO NOT DISCONNECT) on the connection at the ground source.
- 4 Connect the ground lugs of each pedestal together in a daisy-chain arrangement using #6 AWG wire. See Figure 8-2.

Installing and testing personal hazard ground on systems equipped with a QCA13 power cabinet

- 1 If connected, disconnect the -48 V DC power from each pedestal by removing the associated 30A fuse from the power supply panel in the QCA13.
- 2 Connect a #6 AWG wire between the ground window (LRE) on top of the QCA13 cabinet and the ground source (typically the ground bus in the AC power service panel).
- 3 Place a warning tag (WARNING — TELEPHONE SYSTEM GROUND CONNECTION -DO NOT DISCONNECT) on the connection at the ground source.
- 4 Connect a #6 AWG wire between the ground window (LRE) on top of the QCA13 cabinet and the ground lug on the rear of the nearest equipment column.
- 5 Connect the ground lugs of each pedestal together in a daisy-chain arrangement using #6 AWG wire. See Figure 8-2.

Figure 8-1
Main Power Distribution Unit and Pedestal

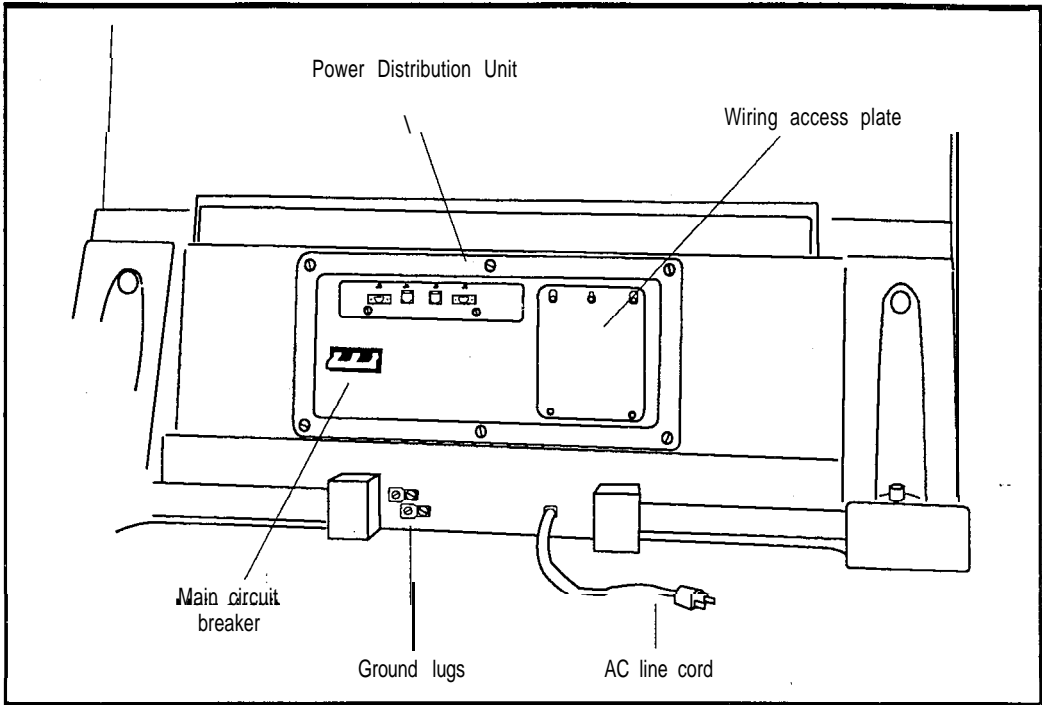
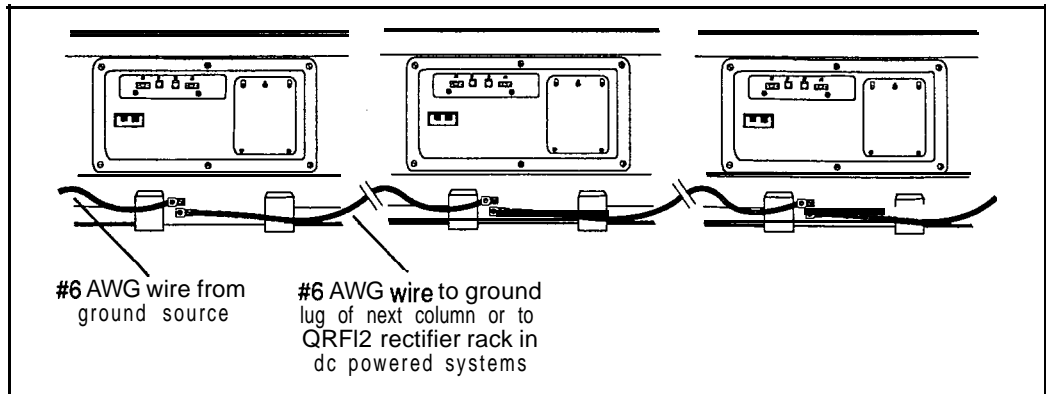

Figure 8-2
Ground wire connection for multiple column system



Installing logic return ground on AC systems

- 1** Remove wiring access plate on each Power Distribution Unit (PDU). See Figure 8-1.
- 2** For a single column system, the logic return ground consists of a three inch shorting strap connecting the LRTN terminal and the GND terminal on the field wiring block. See Figure 8-3.

Note: Perform steps 3 and 4 for multi-column systems only.

- 3** Remove the shorting strap on each field wiring block.
- 4** Starting at the LRE, connect a #8 AWG wire to the column and route it up or down the I/O channel area as appropriate, then through the grommetted hole in the pedestal to LRTN on the field wiring block. See Figure 8-4.
- 5** Replace wiring access plate on each PDU.
- 6** Replace rear pedestal cover of each equipment column.

Figure 8-3
Logic return ground connection for single column AC system

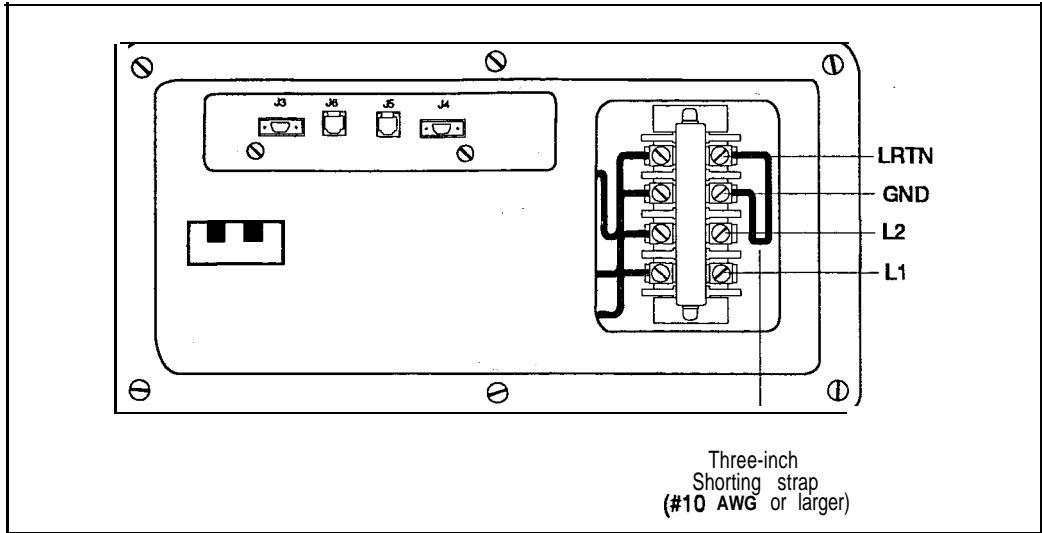
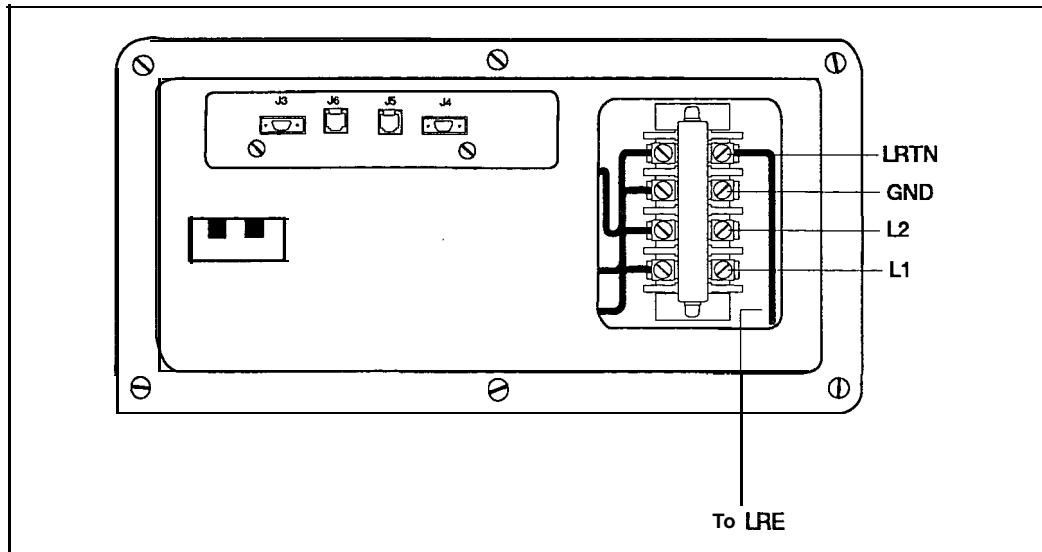

Figure 8-4
Logic return ground connection for each column in a multi-column AC system



Procedure 9: Adjusting and connecting NT6D52 rectifiers

General information

Use this procedure to measure and adjust the output voltage, high voltage shutdown, and current limit for each QRF12 rectifier housed in an NT6D52 enclosed rectifier assembly, and to connect the rectifiers to the system.

Note: Although rectifiers are adjusted during manufacture, they should be measured and readjusted on site if necessary.

A 1 1/4 inch or equivalent flexible type conduit is required for the wiring between the NT6D52 enclosed rectifier and the QBL15 power/battery unit. The conduit should be installed in one of the openings provided for conduit at the rear of the rectifier and in the side or top of the battery distribution box.

One NT6D54AA field wiring kit is required for every three rectifiers being connected. The kit contains the following items:

- One A0290885 male connector
- Four A0290890 connector contacts
- Two P0594300 mounts for cable ties
- Two PO567232 cable ties

Note: One NT8D46AT cable is required for every QBL15 power/battery distribution box connected to a System Monitor. The alarm and trip signals only are passed to the master System Monitor. Alarm and trip signals from additional QBL15s are not used.

When a second QBL15 has been connected, perform the following adjustment and connection routines twice ■ once for each set of rectifiers connected to a QBL 15.

Measuring rectifiers

Use this procedure to measure the high voltage shutdown and to set the float voltage on NT6D.52 rectifiers. Refer to Figure 9-1 while performing this procedure.

- 1 Set the AC BRKR breaker on the front of each rectifier to OFF.
- 2 Check the **220V/110V** switch (switch SW1 located to the left of the AC BRKR switch on the front of the rectifier) and make sure that it is set to the correct voltage. The switch is locked in position by a bracket secured with two screws. It should be set to correspond to the commercial AC power supply provided for the rectifier.
- 3 Remove the rear access plate **from** the **NT6D52** enclosed rectifier and open the front cover on the **QBL15** power/battery distribution box. See Figure 9-1.
- 4 If the AC line cord is not installed, install and connect it to the rear of the rectifier as shown in Figure 9- 1. Plug the line cord into its assigned AC power supply receptacle.
- 5 If connected, disconnect the wires to the **QBL15** power/battery distribution box from terminals 1 and 2 on TB3 at the rear of the rectifier.
- 6 If connected, disconnect the SENSE leads from terminals 2 and 3 of TB4. Strap terminal 1 (+OUT) to terminal 2 (**+SENSE**), and terminal 3 -- (-SENSE) to terminal 4 (-OUT).
- 7 Connect a voltmeter to the + and - OUTPUT test points (1 and 4 of TB4).
- 8 Set the AC BRKR on the front of the rectifier to ON.
- 9 Observe the voltmeter. Gradually turn the VOLTAGE ADJUST potentiometer clockwise and note the output voltage level at which high voltage shutdown occurs. See Table 9-1 for acceptable shutdown voltage settings.
- 10 Turn the VOLT ADJUST potentiometer slightly counterclockwise.

Note: If the shutdown voltage indication does not fall in the range of acceptable values indicated in Table 9-1, adjust the rectifier as indicated in "Adjusting rectifiers," in this section.

- 11 Set the AC BRKR breaker to OFF, then to ON.
- 12 Observe the voltmeter. Adjust the VOLT ADJUST potentiometer until the desired float voltage achieved. See Table 9-1 to select an acceptable float voltage setting.
- 13 Set the AC BRKR breaker to OFF.
- 14 Reconnect the wiring to TB3.
- 15 Remove the temporary straps from TB4 and reconnect the SENSE leads (if previously disconnected).

Note: Perform steps 1 through 15 of this procedure on each rectifier being installed before proceeding.

- 16 If not previously connected, connect the rectifiers to the QBL15 power/battery distribution box. See "Connecting rectifiers" in this section.
- 17 Set the AC BRKR breaker on all rectifiers to ON.
- 18 Make sure that all rectifiers in the system are reconnected and operating, that all the breakers in the system are set to ON and that the system is operating at its maximum load.
- 19 Connect a voltmeter to the + and - OUTPUT test points on the QBL15 battery distribution box. Adjust the VOLT ADJUST potentiometer on the rectifier to obtain a reading equal to the float voltage setting. Repeat this step on all rectifiers in the system.

Make sure that all the rectifiers are adjusted to the same level (± 100 mV maximum).
- 20 Disconnect the AC power line cord until ready to place the rectifier in service.

Figure 9-1
Front view of NT6D52 enclosed rectifier

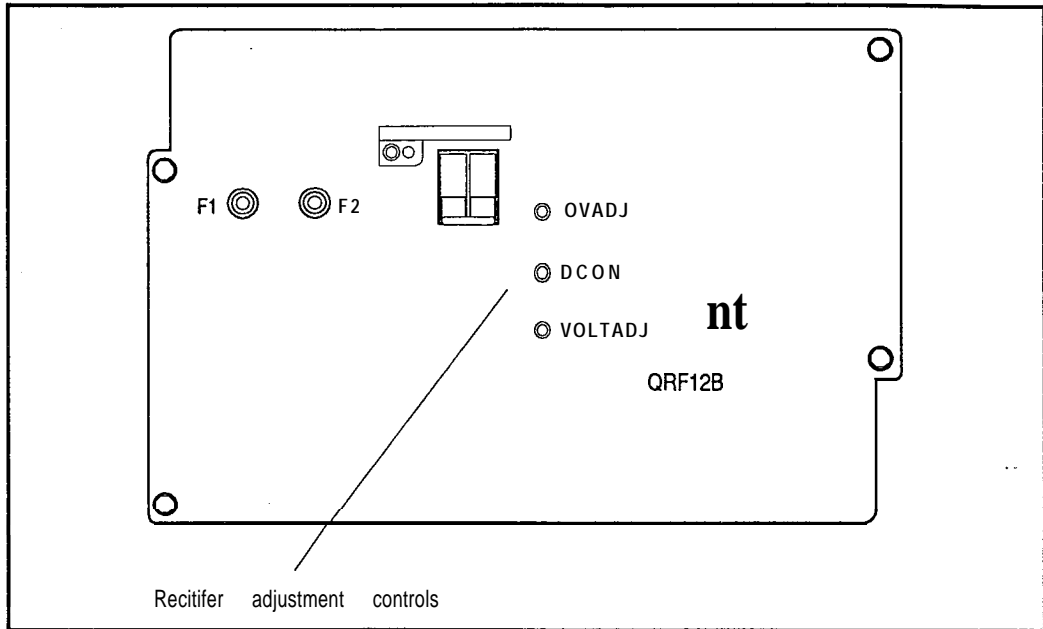

Table 9-1
Rectifier settings

Specification	Range
High Voltage Shutdown	-56.5 to -57.5 V
Float Voltage	-51.5 to -54.0 v
Current Limit	30 Amperes

Adjusting rectifiers

Use this procedure to adjust the high voltage shutdown, the current limit and the float voltage on **NT6D52** rectifiers. Refer to Figure 9-1 while performing this procedure.

- 1 Set the AC BRKR breaker on the **front of** each rectifier to OFF.
- 2 Check the **220V/110V** switch (switch SW1 located to the left of **the** AC BRKR switch on the front of the rectifier) and make sure that it is set to the correct voltage. The switch is locked in position by a bracket secured with two screws. It should be set to correspond to the commercial AC power supply provided for the rectifier.
- 3 Remove the rear access plate from the **NT6D52** enclosed rectifier and open the front cover on the **QBL15** power/battery distribution box. See Figure 9-1.
- 4 If the AC line cord is not installed, install and connect it to the rear of the rectifier as shown in Figure 9-1. Plug the line cord to its assigned AC power supply receptacle.
- 5 If connected, disconnect the wires to the **QBL15** power/battery distribution box from terminals 1 and 2 on TB3 at the rear of the rectifier.
- 6 If connected, disconnect the SENSE leads from terminals 2 and 3 **of** TB4. Strap terminal 1 (+OUT) to terminal 2 (**+SENSE**), and terminal 3 (-SENSE) to terminal 4 (-OUT).
- 7 Turn the OVER VOLTAGE potentiometer fully clockwise.
- 8 Connect a voltmeter to the + and ~ OUTPUT test points.
- 9 Set the AC BRKR on the front of the rectifier to ON.
- 10 Observe the voltmeter. Turn the VOLTAGE ADJUST potentiometer to the desired level of output voltage for high voltage shutdown. See Table 9-1 to select an acceptable shutdown voltage setting.
- 11 Turn the OVER VOLTAGE potentiometer counterclockwise until the voltmeter indicates approximately 0 volts and you hear a relay disengage.
- 12 Turn the VOLT ADJUST potentiometer slightly counterclockwise.
- 13 Set the AC BRKR breaker to OFF then to ON.

- 14 Observe **the** voltmeter. Gradually turn the VOLT ADJUST potentiometer clockwise. The voltmeter should reach a maximum as set in step 7, then drop to 0.
- 15 Repeat steps 4 through 11 until the desired level of overvoltage shutdown is achieved.
- 16 Set the AC BRKR breaker to OFF, then to ON.
- 17 Observe the voltmeter. Adjust the VOLT ADJUST potentiometer until the desired float voltage achieved. See Table 9- 1 to select an acceptable float voltage setting.
- 18 Set the AC BRKR breaker to OFF.
- 19 Perform this step only if current limit adjustments are required.
 - Make sure that steps 1, 2 and 3 are completed.
 - Connect a 48 V, 50 A adjustable load across terminals 1 and 3 of TB3. Set the loads at 38 A.
 - Connect the voltmeter across the 50 A load.
 - Set the AC BRKR breaker to ON.
 - Observe the voltmeter. Adjust the CURRENT LIMIT potentiometer to obtain a reading approximately 1V less than the float voltage setting. --
 - Set the adjustable load to 25 A. The reading on the voltmeter should be equal to the float voltage setting.
 - Set the AC BRKR breaker to OFF. Remove the voltmeter and adjustable load.
- 20 Reconnect the wiring to TB3.
- 21 Remove the temporary straps from TB4 and reconnect the SENSE leads (if previously disconnected).

Note: Measure each rectifier being installed as indicated in “Measuring rectifiers” before performing the remaining steps in **this** procedure.

- 22 If not previously connected, connect the rectifiers to the **QBL15** power/battery distribution box. See “Connecting rectifiers” in this section.
- 23 Set the AC BRKR breaker on all rectifiers to ON.
- 24 Make sure that all rectifiers in the system are reconnected and operating, that all the breakers in the system are set to ON and that the system is operating at its maximum load.
- 25 Connect a voltmeter to the + and – **OUTPUT** test points on the **QBL15** battery distribution box. Adjust the VOLT ADJUST potentiometer on the rectifier to obtain a reading equal to the float voltage setting. Repeat this step on all rectifiers in the system.

Make sure that all the rectifiers are adjusted to the same level (± 100 mV maximum).
- 26 Disconnect the AC power line cord until ready to place the rectifier in service.

Connecting rectifiers

Note: When possible, adjust rectifiers as described above before proceeding to connect the rectifier to the system. --

CAUTION

Check the AC input voltage selection switch.

Make sure that the **220V/110V** switch (switch SW1 located to the left of the AC BRKR switch on the front of the rectifier) is set to the correct voltage.

- 1 If not removed, remove the rear access plate from the rectifier and open the front cover on the **QBL15** battery distribution box.
- 2 If the AC line cord is not installed, install and connect it to the rear of the rectifier as shown in Figure 9-2.

Refer to Figure 9-3 while performing the remaining steps in this procedure.

Note: All wiring between the **QBL15** and the **NT6D52** rectifier is contained inside the same conduit. See Figure 9-3.

- 3 Install one #4 AWG black wire and one red wire from each rectifier to the **QBL15** power/battery distribution box. These wires will be used for +48 V and -48 V connections, and must not exceed a maximum length of 50 feet. They must be run in conduit.
- 4 Install 3 #22 AWG wires from the **QBL15** power/battery distribution box to each rectifier, preferably one red, one black and one blue. However, #24 AWG station wire can be substituted if a full pair is used instead of one #22 AWG wire. These wires will be used for +SENSE, -SENSE and DCON connections and must be run in the same conduit as the +48 V and -48 V wiring from the rectifier.
- 5 Connect the #4 AWG black wires to terminal 2 (+48V) on TB3 in the rectifier and to the +VE BUS in the **QBL15** battery distribution box..
- 6 Connect the #4 AWG red wires to terminal 1 (-48V) on TB3 in the rectifier and to CHARGE 1, 2 or 3 (terminal 9, 10 or 11) on TB1 in the **QBL15** battery distribution box.
- 7 Connect a 22 AWG black wire (or a twisted pair of #24 AWG station wire) to terminal 2 (+SENSE) on TB4 in the rectifier and to terminal 1, 3 or 5 (+SENSE) on TB3 in the **QBL15** battery distribution box.
- 8 Connect a 22 AWG red wire (or a twisted pair of #24 AWG station wire) to terminal 3 (-SENSE) on TB4 in the rectifier and to terminal 2, 4 or 6 (-SENSE) on TB3 in the **QBL15** battery distribution box.
- 9 Connect a 22 AWG blue wire (or a twisted pair of #24 AWG station wire) to terminal 5 (DCON) on TB4 in the rectifier. This wire will connect to the field wiring kit in the **QBL15** power/battery distribution box.
- 10 If not previously installed, install an **NT8D46AT** cable at the **QBL15** battery distribution box, as illustrated in Figure 9-3. Conduit is not required for this wiring. Connecting the other end of the **NT8D46AT** cable at the System Monitor is performed in **Procedure 18: Installing System Monitor cabling**.

Note: Not every System Monitor requires an **NT8D46AT** cable. One cable is required for every **QBL15** power/battery distribution box connected to a System Monitor.

- 11 This step is performed in the **QBL15** battery box and requires a **NT6D54AA** field wiring kit. Refer to Figure 9-4 while completing this step.
 - Remove approximately $\frac{1}{4}$ in. (6 mm) of insulation from the end of the DCON wire from the rectifier.
 - With an AMP **90296-type** crimping tool, install one A0290890 connector contact on the skinned wire.
 - Label the wire DCON0 (or **DCON1** or DCON2 as appropriate).
 - Insert the connector contact in the A0290885 male connector.
 - Connect the male connector to the A0290886 female connector on the end of the **NT8D46AT** cable.
 - Secure the connectors to the left inside panel of the **QBL15** with cable tie mounts and cable ties supplied with the kit.
 - If not previously connected, connect the orange wire from the **NT8D46AT** cable to terminal 5 (ALARM) and the brown wire to terminal 6 (TRIP) of TB2 in the **QBL15** box.
- 12 Secure the conduits and wiring neatly to the relay rack with cable ties.
- 13 Close the cover on the **QBL15** battery distribution box if work is -- completed.
- 14 Reinstall the rear access plate on the **NT6D52** enclosed rectifier unless rectifier voltage adjustments are not completed.

9-10 Adjusting and connecting NT6D52 rectifiers

Figure 9-2
Rear view of NT6D52 enclosed rectifier

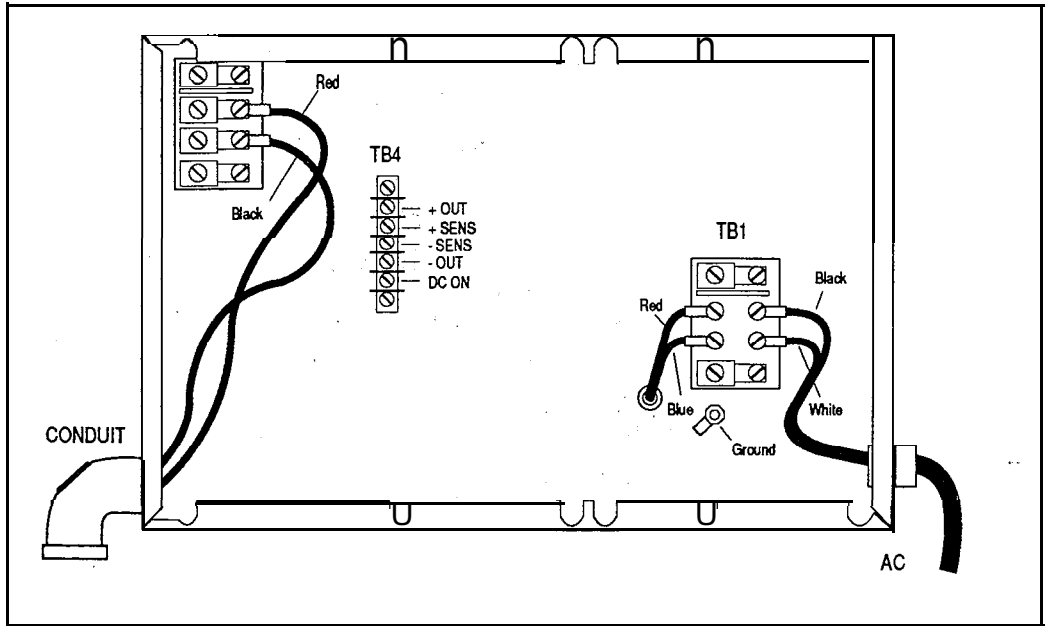
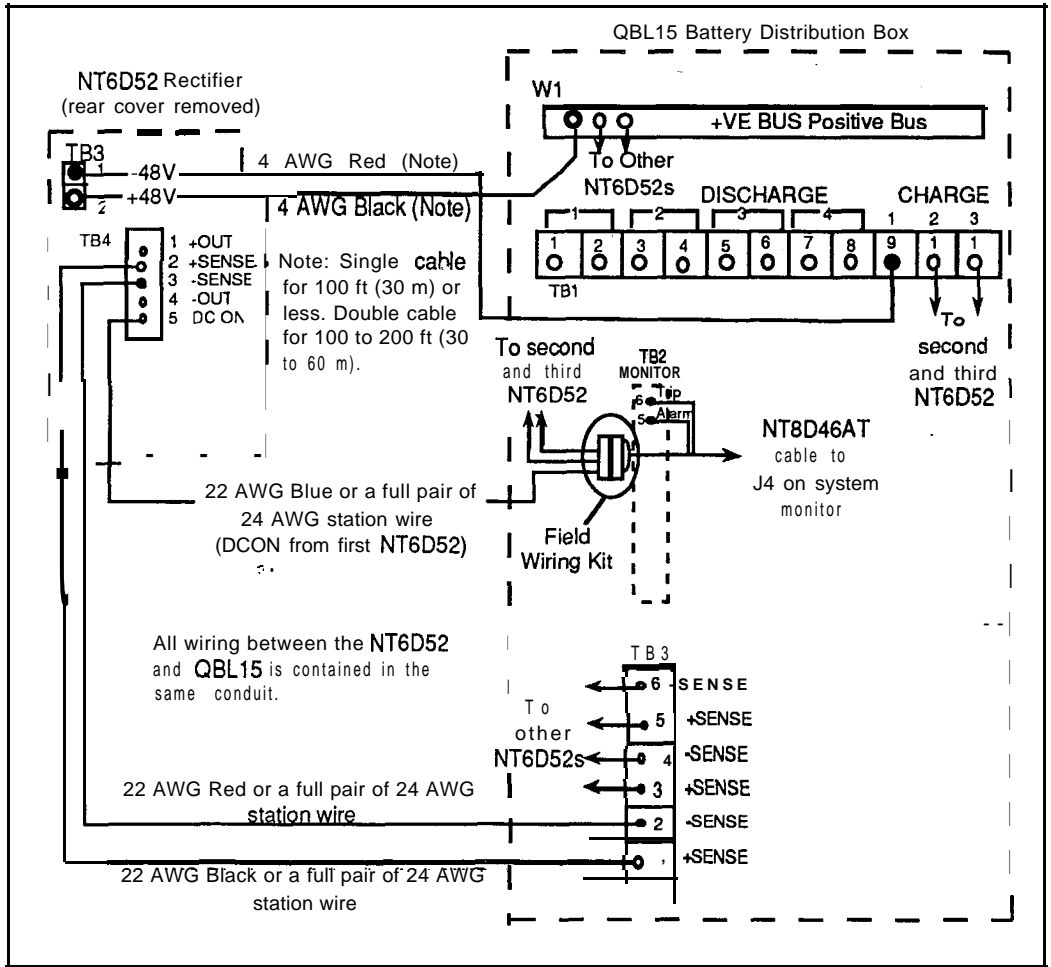
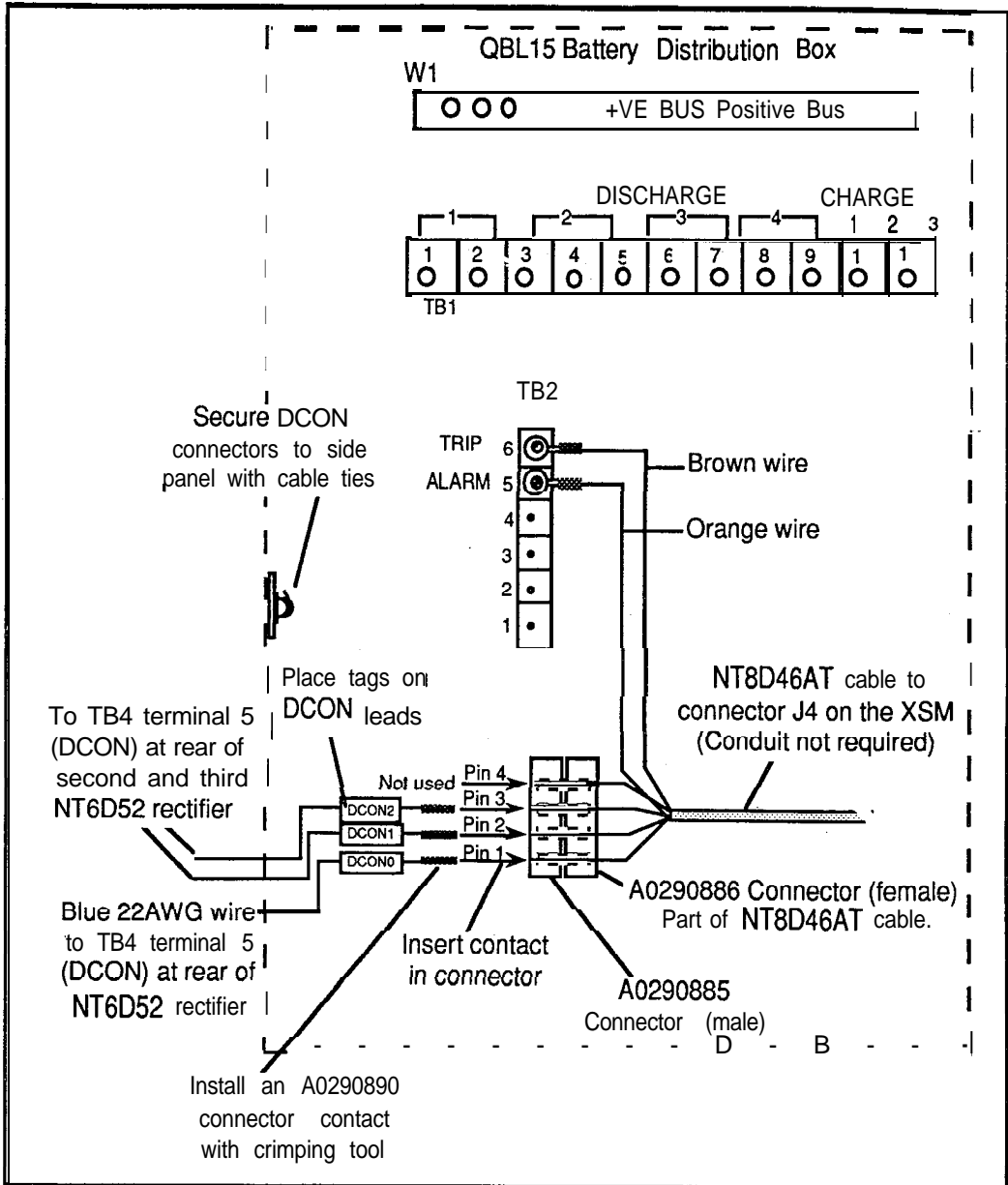

Figure 9-3
Rectifier to QBL15 connections



9-12 Adjusting and connecting NT6D52 rectifiers

Figure 9-4
NT6D54AA field wiring kit connections



Procedure IO: Installing a reserve power system

General information

Use this procedure to install alarm and ground cabling for AC systems when a reserve power system (UPS) is equipped. A typical UPS configuration will have one UPS providing power to each UEM column. Refer to *Power engineering (553-3001-152)* for UPS requirements.

Cabling between the UPS and a UEM column consists of a special alarm cable and frame grounds for safety. The UPS manufacturer's documentation should be in hand when doing this procedure. Refer to the manufacturer's documents for installation of **the** UPS.

Three manufacturer's UPS equipment has been tested for use **with the** SL-1. A special alarm cable is available for connecting the System Monitor to the UPS for each vendor tested. The cables are:

Best Power Technologies NT8D46A.1

Exide Electronics NT8D46AQ

Alpha Technologies NT8D46AU --

CAUTION

Follow manufacturer's instructions carefully when connecting DC battery leads to a UPS. A battery reversal may cause severe damage to the UPS.

Ground cabling

The preferred method to connect the UPS and the system frame grounds is to daisy chain each UPS to a common frame ground point. If bypass switches are used for the UPS they should be daisy chained and connected to **the** same common ground point.

It is recommended that all **UEMs** be daisy chained and connected to the IG bus in the AC panel. If a UPS is used, the system frame ground, the bypass switch ground, and the **UPS** frame ground are connected to a common point and the common ground point connected to the IG bus in the AC panel.

UPS alarm cable installation

- 1 Connect the alarm cable (see above for list of cables) to connector J4 of the System Monitor in column 0 and run the other end of the cable to the UPS. Terminate the cable at the UPS as specified by the manufacturer's documentation.
 - Figure 10-1 illustrates the alarm connections for a UPS.
 - Table 10-1 illustrates the **the signal** names and pin assignments on the alarm cables.
- 2 Repeat step 1 for each UPS equipped.

Figure 10-1
UPS alarm cabling

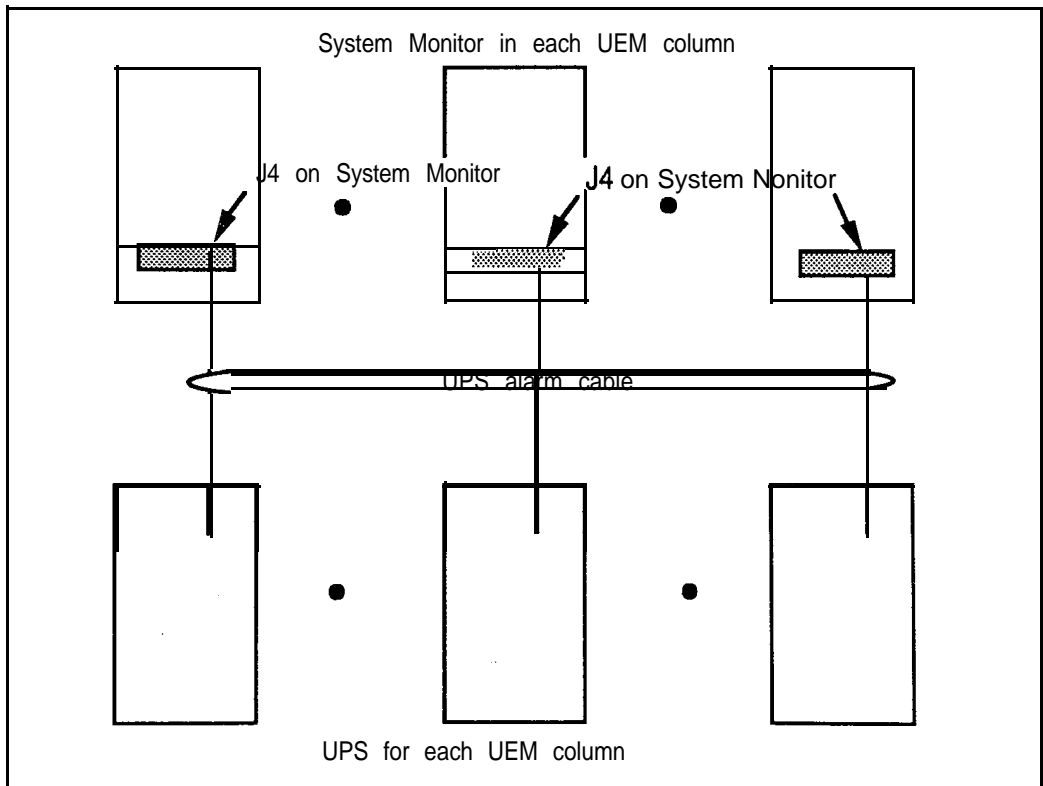

Table 1 0-1
UPS alarm cable assignment

NT8D46 AJ, AQ, AU Pin Number	Signal
1	Not Used
2	Not Used
3	Not Used
4	Not Used
5	Alarm 1
6	Alarm 1 Return
7	Alarm 2
8	Alarm 2 Return
9	Not Used

UPS frame ground cable installation

- 1 Daisy chain each UPS using #6 AWG wire. See Figure 10-2.
- 2 Daisy chain each bypass switch (if equipped) with #6 AWG wire.
- 3 Ensure that all equipment columns are daisy chained together.
- 4 Run a #6 AWG wire between the SL-1 system frame ground lug, the bypass switches, and the UPS to a common **frame** ground point,
- 5 Run a #6 AWG wire between the common ground point and the IG bus in the AC panel.

10-4 Installing a reserve power system

Figure 10-2
UPS grounding diagram

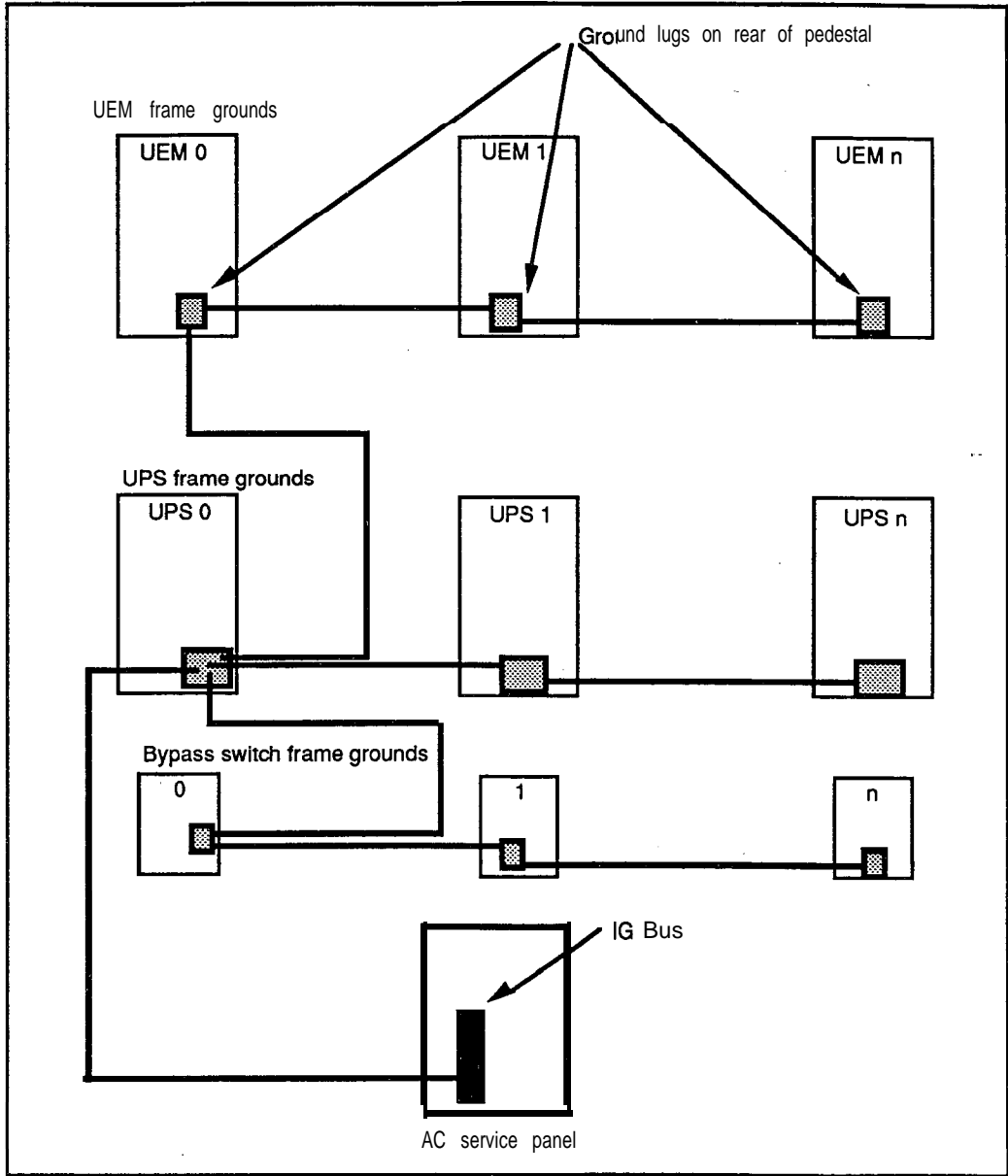

Procedure 11: Connecting DC power to a UEM from a QBL15 power/battery distribution box

General information

Use this procedure to connect -48 V dc power from a QBL15 power/battery distribution box to a pedestal. The QBL15 power/battery distribution box is used with an NT6D52 enclosed rectifier supplied by Northern Telecom. Refer to *Power engineering* (553-3001-152) for information about calculating the size and number of power conductors required.

Power wiring to the pedestal is installed in a flexible metallic conduit. Four holes are provided for 3/4 in. conduit in the pedestal allowing power wiring to be routed through the top, rear or bottom of the pedestal. (see Figures 11-1 and 11-2). A maximum of nine #10 AWG wires or five #8 AWG wires can be installed in the 3/4 in. conduit. A maximum loop drop of 2 volts is allowed between the UEM and the QBL15. See Table 11-1 for allowable wire sizes.

Red wire should be used for the BAT connections and black wire should be used for the RTN connections. The logic return (LRTN) wire must also be included in the conduit. Note that the +VE bus in the QBL15 power/battery distribution box is used as the LRE.

Some installations will require an NT6D53AA junction box (see Table 11-1). The NT6D53AA junction box is equipped with a flexible conduit 10 ft (3050 mm) long containing all the necessary wiring to connect the DC power to TB 1 in the pedestal. It should be installed close enough to the pedestal to allow the flexible conduit to reach terminal block TB1 in the bottom of the pedestal. Two 1 1/4 in. conduits can be installed from the power source to the junction box. The connections in the box can accept up to #4 AWG size wire.

When connecting to a QBL15 power/battery distribution box, one NT8D46AT cable is required to extend the alarm, trip and DCON leads to the Master System Monitor in the pedestal. A second NT8D46AT cable is used to extend additional DCON signals to slave System Monitor units. These cables do not require conduit.

Connecting DC power

- 1 Open the front panel on the **QBL15** power/battery distribution box.

Note: Perform steps 2 through 8 for each equipment column.

- 2 Perform this step only if the Power Distribution Unit (**PDU**) is not presently removed from the pedestal.
 - Remove the rear grill from the pedestal.
 - Remove the rear cover from the UEM directly above the PDU.
 - Remove the rear plate from the I/O panel and disconnect the XSM and power cable going from the UEM to the PDU.
 - If the UEM is equipped with an **SDI** paddle board on its backplane, temporarily remove it to avoid damage.
 - Disconnect any cables that are connected to the jacks on the front of the XSM.
 - Loosen the retaining screws securing the Power Distribution Unit (**PDU**).
 - Remove the PDU to reveal the field terminal block **TB 1** in the bottom of the pedestal. See Figure 11-3.
- 3 Install the junction box, if one is required, near the pedestal that it is intended to serve. Install the flexible conduit from the box in one of the conduit access holes in the pedestal.

Connect the wires from the junction box to the corresponding connections on terminal block **TB 1** in the bottom of the pedestal. To facilitated connecting, the wires are **labelled** and color coded as follows:

- The red wires are **labelled** **BAT0** through **BAT3**.
- The black wires are **labelled** **RTNO** through **RTN3**.
- The green wire is **labelled** **FGRD**.
- The remaining wire (which is usually orange, but may be another color) is **labelled** **LRTN**.

- 4 Install the number of power wires required from the **QBL15** to the pedestal or junction box. The 48 V wiring should be red, the **+48 V** wiring should be black, and the LRTN wire should be orange. The -48 V and **+48 V** wiring should be installed in the same conduit and **must** include the LRTN (logic return) wire.
- 5 Connect the -BAT wiring (red wires) from terminals **1, 2,** or 3 on terminal block **TB1 (DISCHARGE)** in the **QBL15** power/battery distribution box to TB 1 in the bottom of the pedestal or in the **NT6D53AA** junction box if one is provided. See Figure 1 I-4.

If one wire is used to feed **-48 V** to two **UEMs** (total of two red wires for -BAT connections) connect as follows:

- For **UEM 0** and **UEM1**, connect to **-BAT0** and add a strap (if not already installed) between **-BAT0** and **-BAT1** in the pedestal or in the junction box if one is provided.
- For **UEM 2** and **UEM 3**, connect to **-BAT2** and add a **strap** (if not already installed) between **-BAT2** and **-BAT3** in the pedestal or in the junction box if one is provided.

If one wire is used to feed **-48 V** to each **UEM** (four red wires for -BAT connections) remove straps (if installed) between **-BAT0** and **-BAT1**, and **-BAT2** and **-BAT3**, and connect one wire for each **UEM** as follows:

- For **UEM 0**, connect to **-BAT0**
 - For **UEM 1**, connect to **-BAT1**
 - For **UEM 2**, connect to **-BAT2**
 - For **UEM 3**, connect to **-BAT3**
- 6 Connect the RTN wiring (black wires) from the +VE BUS in the **QBL 15** power/battery distribution box to TB 1 in the bottom of the pedestal or in the **NT6D53AA** junction box if one is provided, See Figure 1 I-4.

If one wire is used to feed +48 V to two UEMs (total of two black wires for +RTN connections) connect as follows:

- For UEM 0 and UEM1, connect to +RTNO and add a strap (if not already installed) between +RTNO and +RTN1 in the pedestal or in the junction box if one is provided.
- For UEM 2 and UEM 3, connect to +RTN2 and add a strap (if not already installed) between +RTN2 and +RTN3 in the pedestal or in the junction box if one is provided.

If one wire is used to feed +48 V to each UEM (four black wires for +RTN connections) remove straps (if installed) between -RTNO and -RTN1, and -RTN2 and -RTN3, and connect one wire for each UEM as follows:

- For UEM 0, connect to +RTNO
- For UEM 1, connect to +RTN1
- For UEM 2, connect to +RTN2
- For UEM 3, connect to +RTN3

7 Connect an orange #8AWG LRTN wire from the positive VE bus of the QBL15 to LRTN on TB1 in the pedestal. See Figure 11-4. --

8 Reinstall the PDU as follows:

- If the pedestal is equipped with a blower unit, remove the front grill from the pedestal and slide the blower unit out approximately 3 in. (75 mm).
- Insert the PDU and secure it with its retaining screws,
- Insert the blower unit until it is properly plugged into the PDU.
- Reinstall the front grill on the pedestal.
- Reconnect the XSM and power cables going from the UEM to the top of the PDU.
- Reinstall the XSDI circuit pack on the UEM's backplane if it was temporarily removed.
- Reinstall the rear plate on the I/O panel.
- Reinstall the rear cover on the UEM directly above the PDU.

- Reconnect any cables that **were** disconnected from the jacks on the front of the XSM.
 - Reinstall the rear grill on the pedestal.
- 9 Check the DISCHARGE fuses in the **QBL15** power/battery distribution box. If necessary, install the fuses.
 - 10 Close the front panel on the **QBL15** power/battery distribution box.

Figure 11-1
Conduit fittings for rear-exit conduit

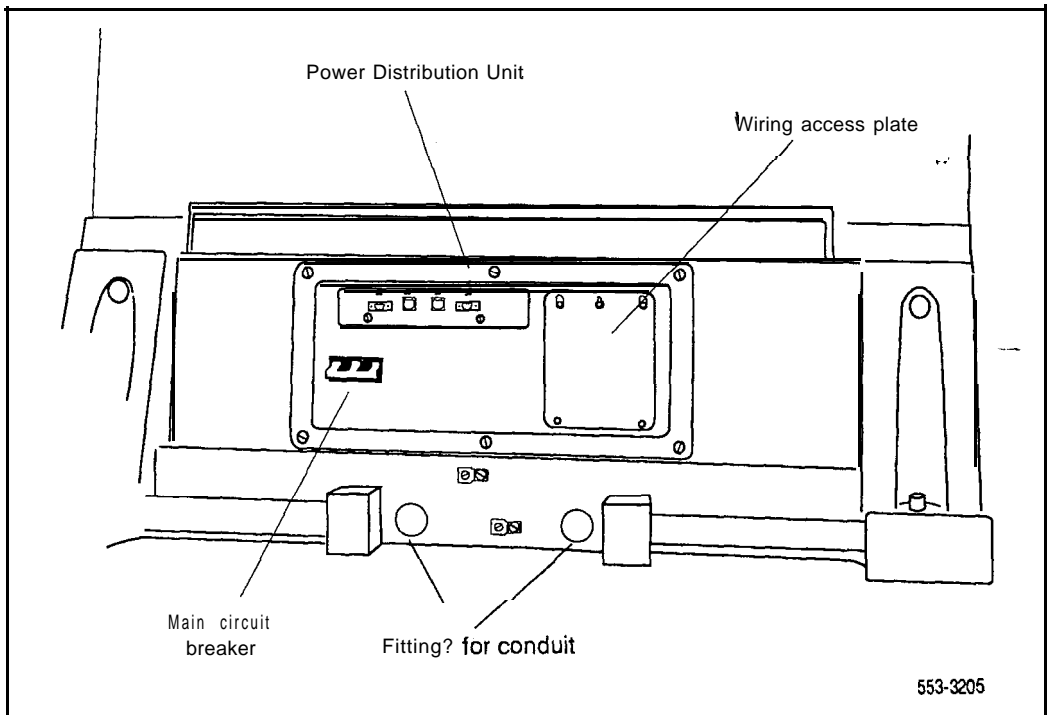

Figure 11-2
Conduit fittings for up or down exit conduit

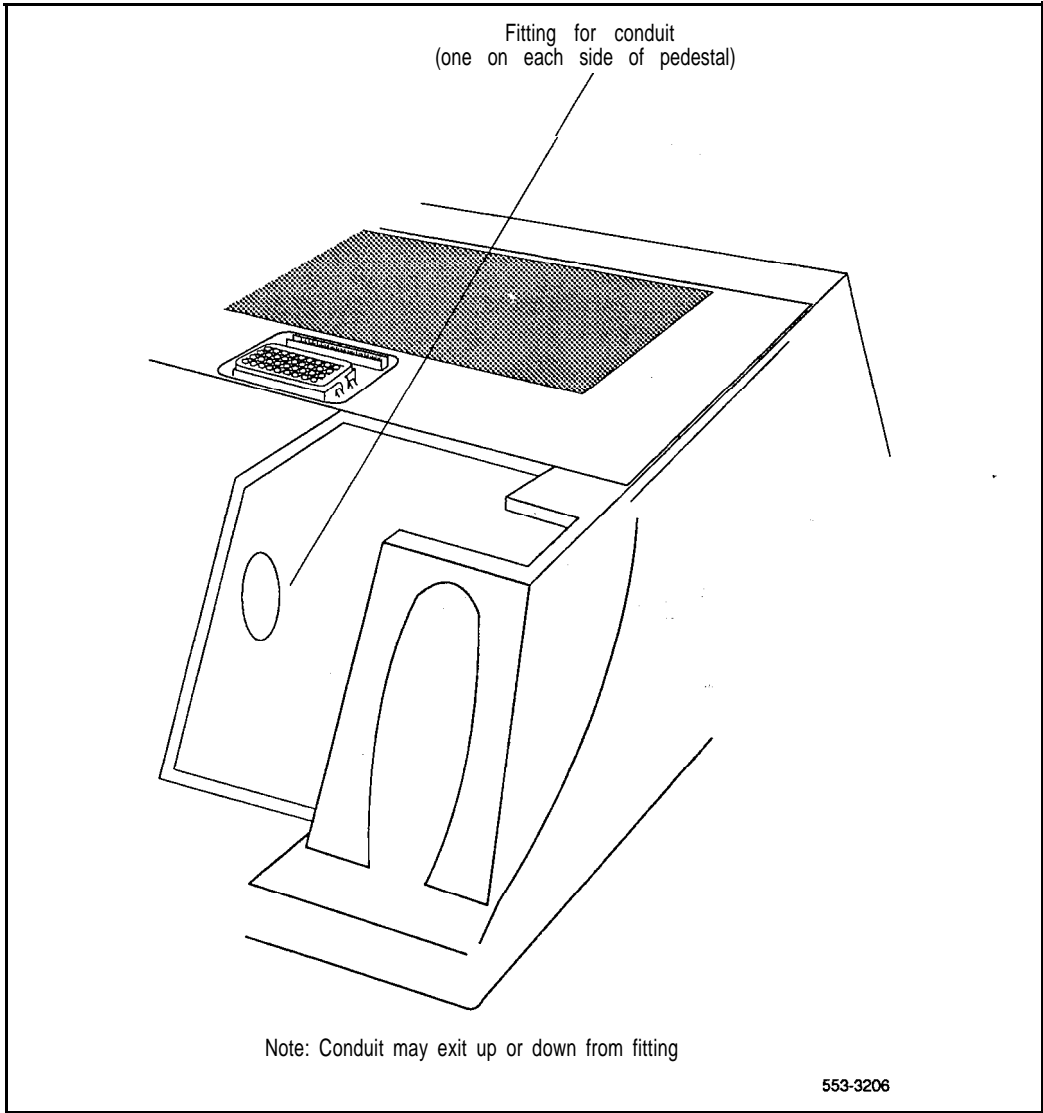

Figure 11-3
Field terminal block (TB1) access

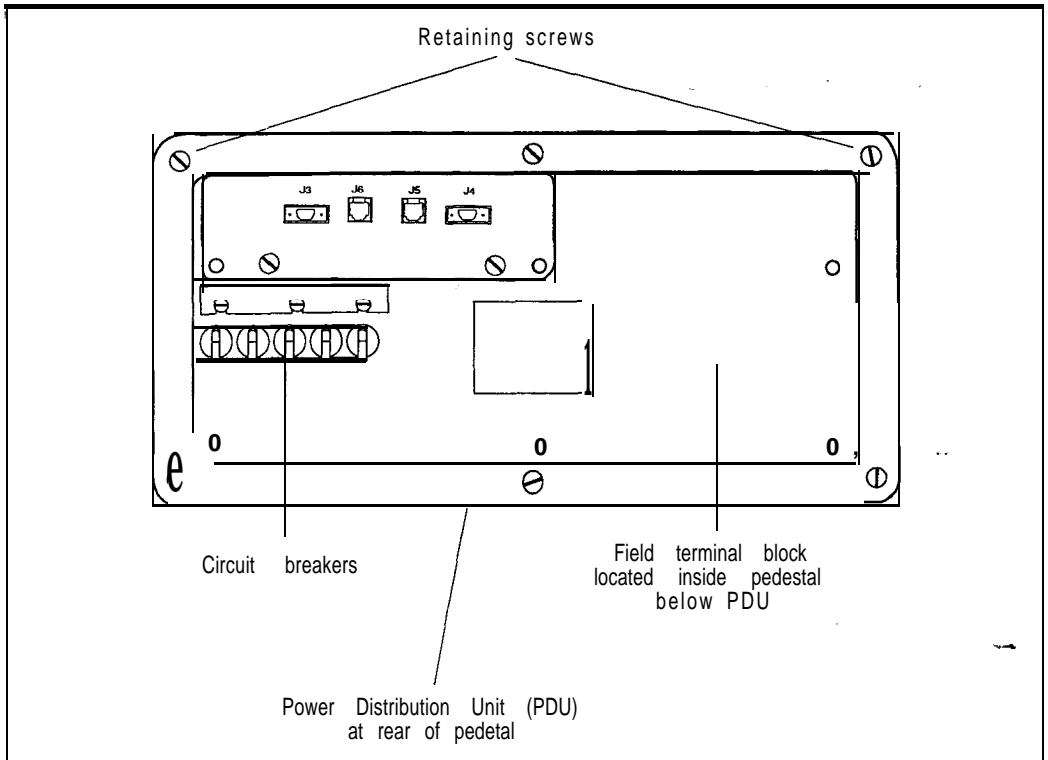

Figure 11-4
UEM to QBL15 connections

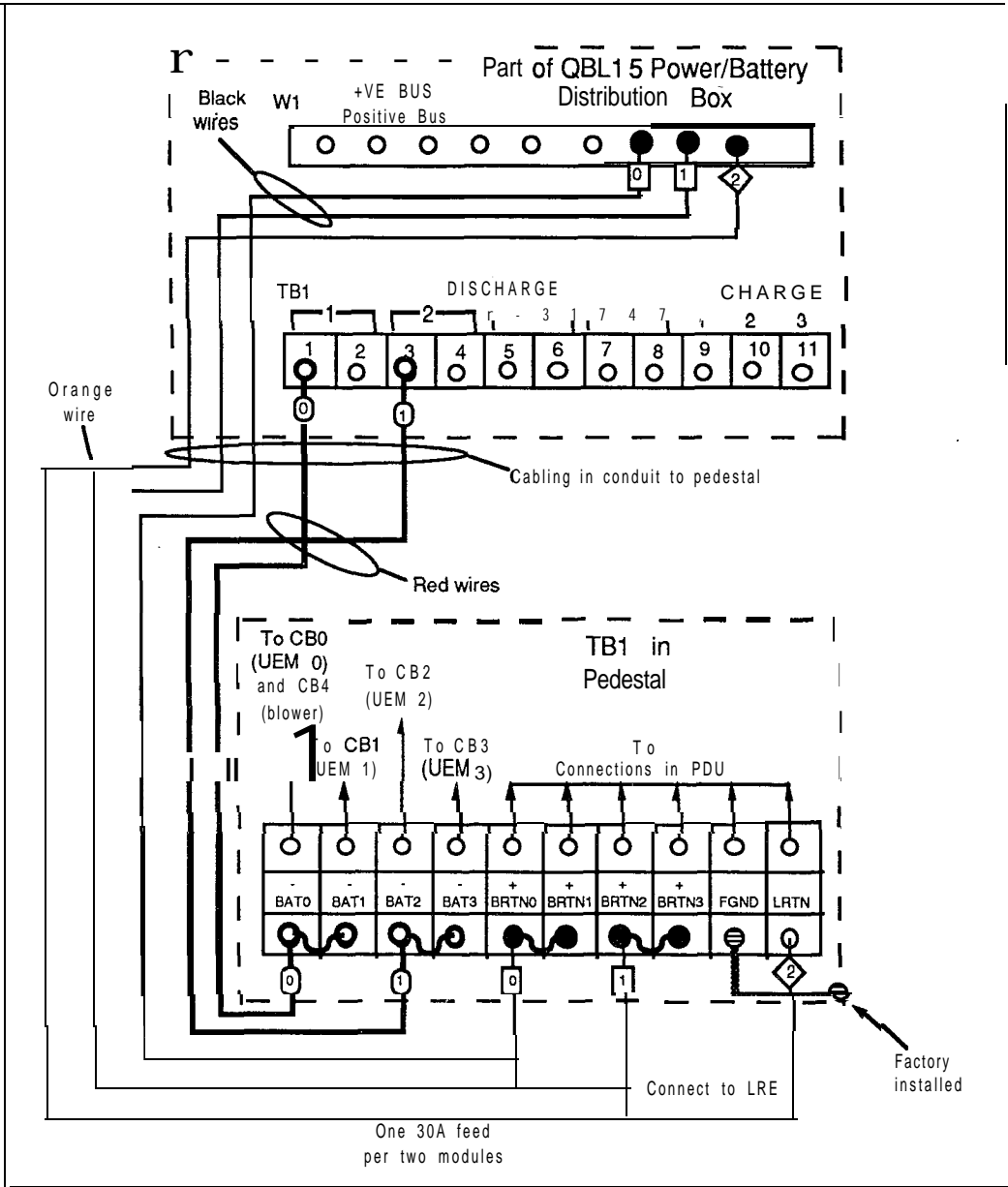

Table 11-I
Pedestal wire gauge requirements with a 30 A feed

Length	Wire AWG			
	Single conduit	Dual conduit	Junction box with single #4 AWG*	Junction box with double #4 AWG*
	8	6	4	4
0 - 10 ft	Yes	Yes	Yes	Yes
0-20ft	Yes	Yes	Yes	Yes
0-30ft	Yes	Yes	Yes	Yes
0-40ft	Yes	Yes	Yes	Yes
0 - 50 ft	Yes	Yes	Yes	Yes
0-60ft	No	Yes	Yes	Yes
0-70ft	No	Yes	Yes	Yes
0-80ft	No	Yes	Yes	Yes
0 - 90 ft	No	No	Yes	Yes
0 -100 ft	No	No	Yes	Yes
0 -200 ft	No	No	No	Yes
200 + ft	No	No	No	No

Note 1: Two 30 A feeds are typically adequate for a full column of 4 modules (two 30 A feed pairs plus Logic return).

Note 2: When using dual conduit, the wires must be run in BAT/BR pairs. One pair in one conduit and one pair plus LRTN in the other conduit.

* A single or double run of 4 AWG wire from the distribution point to a junction box near the pedestal. 10 AWG wire is run from the junction box into the pedestal PDU terminal board.

Legend: Yes = Wire size is adequate for the distance.
 No = Wire size has too high a voltage drop and is inadequate for the distance.



Procedure 12: Connecting DC power to a UEM from a QBL12 power/battery distribution box or a QCA13 power cabinet

General information

Use this procedure to connect DC power from a QBL12 power/battery distribution box or a QCA13 power cabinet to a UEM. Refer to *Power engineering* (553-3001-152) for information about calculating the size and number of power conductors required.

Power wiring to the pedestal is installed in a flexible metallic conduit. Four holes are provided for 3/4 in. conduit in the pedestal allowing power wiring to be routed through the top, rear or bottom of the pedestal. (see Figures 12-1 and 12-2). A maximum of nine #10 AWG wires or five # 8 AWG wires can be installed in the 3/4 in. conduit. A maximum loop drop of 2 volts is allowed between the UEM and the QBL12/QCA13. See Table 12-1 for acceptable wire sizes.

Red wire should be used for the BAT connections and black wire should be used for the RTN connections. The logic return (LRTN) wire must be included in the conduit. The LRE consists of a copper busbar which is mounted on top of the QCA13 cabinet or on a wall adjacent to the QBL12.

Some installations will require an NT6D53AA junction box (see Table 12-1). The NT6D53AA junction box is equipped with a flexible conduit 10 ft (3050 mm) long containing all the necessary wiring to connect the DC power to TB 1 in the pedestal. It should be installed close enough to the pedestal to allow the flexible conduit to reach terminal block TBI in the bottom of the pedestal, Two 1 1/4 in. conduits can be installed from the power source to the junction box. The connections in the box can accept up to #4 AWG size wire.

When connecting to a QBL12 power/battery distribution box, one NT8D46AW cable is required to extend the alarm and trip leads to the Master System Monitor in the pedestal. This cable does not require conduit. When connecting to a QCA13 power cabinet, one NT8D46AV cable is required to extend the alarm and trip leads to the Master System Monitor. This cable does not require conduit.

Connecting DC power

- 1 Open the front panel on the QBL12 power/battery distribution box or on the QCA13 power cabinet.

Note: Perform steps 2 through 8 for each equipment column.

- 2 Perform this step only if the Power Distribution Unit (PDU) is not presently removed from the pedestal.
 - Remove the rear grill from the pedestal.
 - Remove the rear cover from the UEM directly above the PDU.
 - Remove the rear plate from the I/O panel and disconnect the System Monitor and power cable going from the UEM to the PDU.
 - If the UEM is equipped with an SDI paddle board on its backplane, temporarily remove it to avoid damage.
 - Disconnect any cables that are connected to the jacks on the front of the System Monitor.
 - Loosen the retaining screws securing the Power Distribution Unit (PDU).
 - Remove the PDU to reveal the field terminal block TB 1 in the bottom of the pedestal. See Figure 12-3.
- 3 Install the junction box, if one is required, near the pedestal that it is intended to serve. Install the flexible conduit from the box in one of the conduit access holes in the pedestal.

Connect the wires from the junction box to the corresponding connections on terminal block TB 1 in the bottom of the pedestal. To facilitate connecting, the wires are **labelled** and color coded as follows:

- The red wires are **labelled** BAT0 through BAT3.
- The black wires are **labelled** RTNO through RTN3.
- The green wire is **labelled** FGRD.
- The remaining wire (which is usually orange but may be another color) is **labelled** LRTN.

- 4 Install the number of power wires required from the **QBL12/QCA13** to the pedestal or junction box. The -48 V wiring should be red, the +48 V wiring should be black, and the LRTN Wire should be orange. The -48 V and +48 V wiring must be installed in the same conduit and must include the LRTN (logic return) wire.
- 5 Connect the -BAT wiring (red wires) from the first four available -48 V output connections on the -48 V terminal panel in the QBL12 or QCA13 power cabinet to **TB 1** in the bottom of the pedestal or in the **NT6D53AA** junction box if one is provided. See Figure 12-4.

If one wire is used to feed -48 V to two UEMs (total of two red wires for -BAT connections) connect as follows:

- For UEM 0 and UEM1, connect to **-BAT0** and add a strap (if not already installed) between **-BAT0** and **-BAT1** in the pedestal or in the junction box if one is provided.
- For UEM 2 and UEM 3, connect to **-BAT2** and add a strap (if not already installed) between **-BAT2** and **-BAT3** in the pedestal or in the junction box if one is provided.

If one wire is used to feed -48 V to each UEM (four red wires for -BAT connections) remove straps (if installed) between **-BAT0** and **-BAT1**, and **-BAT2** and **-BAT3**, and connect one wire for each UEM as follows:

- For UEM 0, connect to **-BAT0**
 - For UEM 1, connect to **-BAT1**
 - For UEM 2, connect to **-BAT2**
 - For UEM 3, connect to **-BAT3**
- 6 Connect the +RTN wiring (black wires) from the the LRE (ground window) to **TB1** in the bottom of the pedestal or in the **NT6D53AA** junction box if one is provided. See Figure 12-4.

If one wire is used to feed **+48 V** to **two UEMs** (total of two black wires for **+RTN** connections) connect as follows:

- For UEM 0 and **UEM1**, connect to **+RTN0** and add a strap (if not already installed) between **+RTN0** and **+RTN1** in the pedestal or in the junction box if one is provided.
- For UEM 2 and UEM 3, connect to **+RTN2** and add a strap (if not already installed) between **+RTN2** and **+RTN3** in the pedestal or in the junction box if one is provided.

If one wire is used to feed **+48 V** to each UEM (four black wires for **+RTN** connections) remove straps (if installed) between **-RTN0** and **-RTN1**, and **-RTN2** and **-RTN3**, and connect one wire for each UEM as follows:

- For UEM 0, connect to **+RTN0**
- For UEM 1, connect to **+RTN1**
- For UEM 2, connect to **+RTN2**
- For **UEM 3**, connect to **+RTN3**

7 Connect an orange **#8 AWG LRTN** wire from the LRE (ground window) to LRTN on **TB1** in the pedestal. See Figure 12-4.

8 Reinstall the PDU as follows:

- If the pedestal is equipped with a blower unit, remove the front grill from the pedestal and slide the blower unit out approximately 3 in. (75 mm).
- Insert the PDU and secure it with its retaining screws.
- Insert the blower unit until it is properly plugged into the PDU.
- Reinstall the front grill on the pedestal.
- Reconnect the XSM and power cables going from the UEM to the top of the PDU.
- Reinstall the XSDI circuit pack on the **UEM's** backplane if it was temporarily removed.
- Reinstall the rear plate on the I/O panel.
- Reinstall the rear cover on the UEM directly above the PDU.

- Reconnect any cables that were disconnected from the jacks on the front of the XSM.
 - Reinstall the rear grill on the pedestal.
- 9 This step applies to the first pedestal being connected to each QBL12 power/battery distribution box only. Connect an **NT8D46AW** cable to extend the trip and alarm connections from the QBL12 to the System Monitor in the pedestal.
- Install the **NT8D46AW** cable at terminal block TB3 in the QBL12 power/battery distribution box. Connect the cable at TB3 as follows. Note that the wires are color coded and labelled.
- Connect the orange wire (ALARM) to terminal 3.
 - Connect the brown wire (TRIP) to terminal 4.
 - Connect the black wire (DCONO) to terminal 6. The DCON connection from the rectifier should also be terminated on terminal 6.
- 10 This step applies to the first pedestal being connected to each QCA13 power cabinet only. It requires an **NT8D46AV** cable to extend the DCON connection from the rectifiers and the trip and alarm connections from the QCA13 to the System Monitor in the pedestal.
- Install the **NT8D46AV** cable at terminal strip TSA in the **QCA13** power cabinet. Connect the cable at TSA as follows. Note **that** the wires are color coded and labelled.
- Connect the orange wire (ALARM) to terminal 50.
 - Connect the brown wire (TRIP) to terminal 49.
- 11 Install the rear grill on the pedestal.
- 12 Check the DISCHARGE fuses in the QBL12 power/battery distribution box or QCA13 power cabinet. If necessary, install the fuses.
- 13 Close the front panel on the QBL12 battery distribution box or QCA13 power cabinet if work operations in the box or cabinet are completed.

Figure 12-1
Conduit fittings for rear-exit conduit

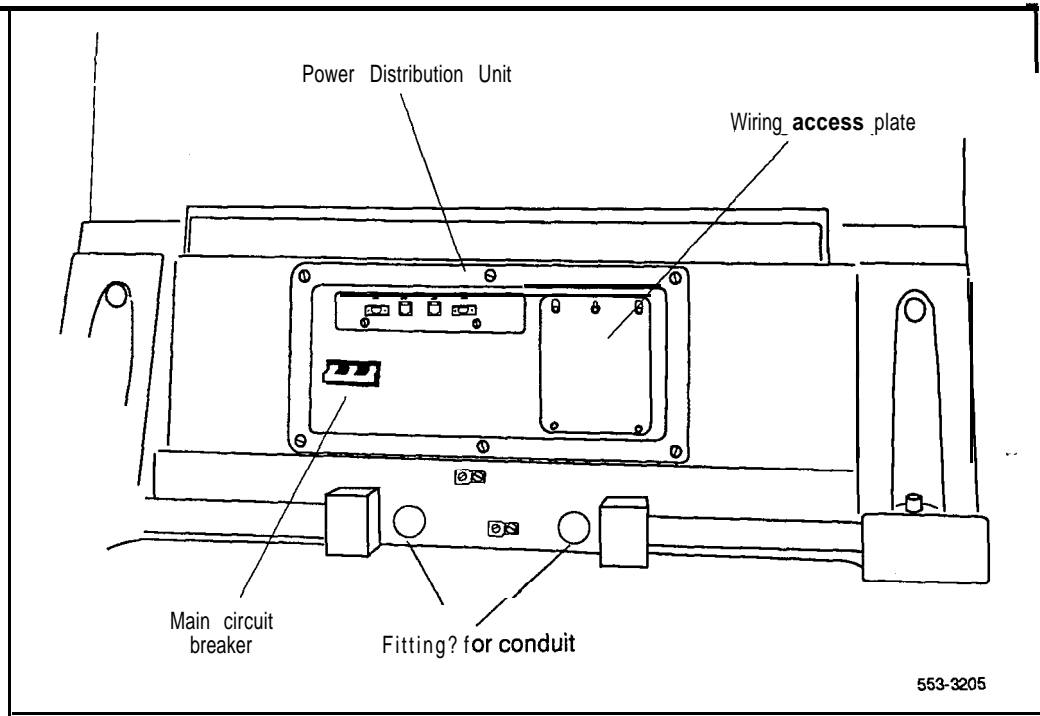

Figure 12-2
Conduit fittings for up or down exit conduit

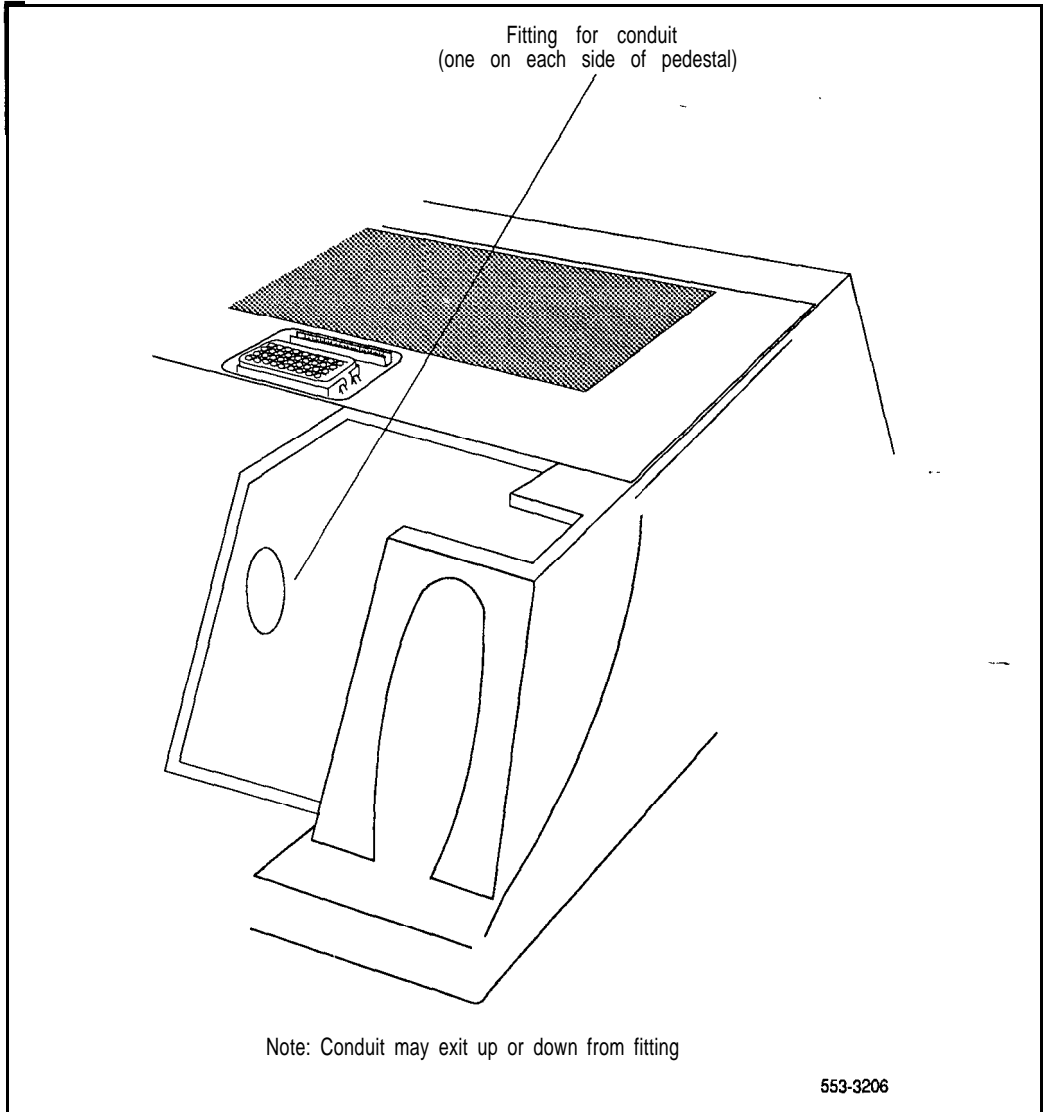

Figure 12-3
Field terminal block (TB1) access

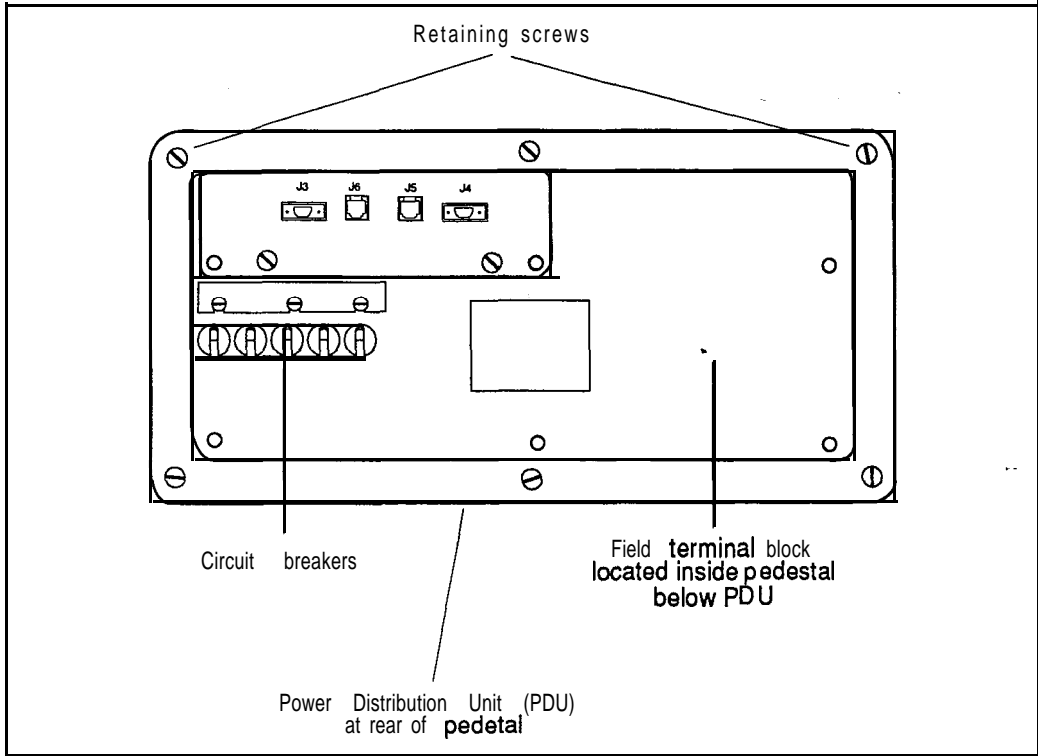

Figure 12-4
UEM to QBL12 (or QCA13) connections

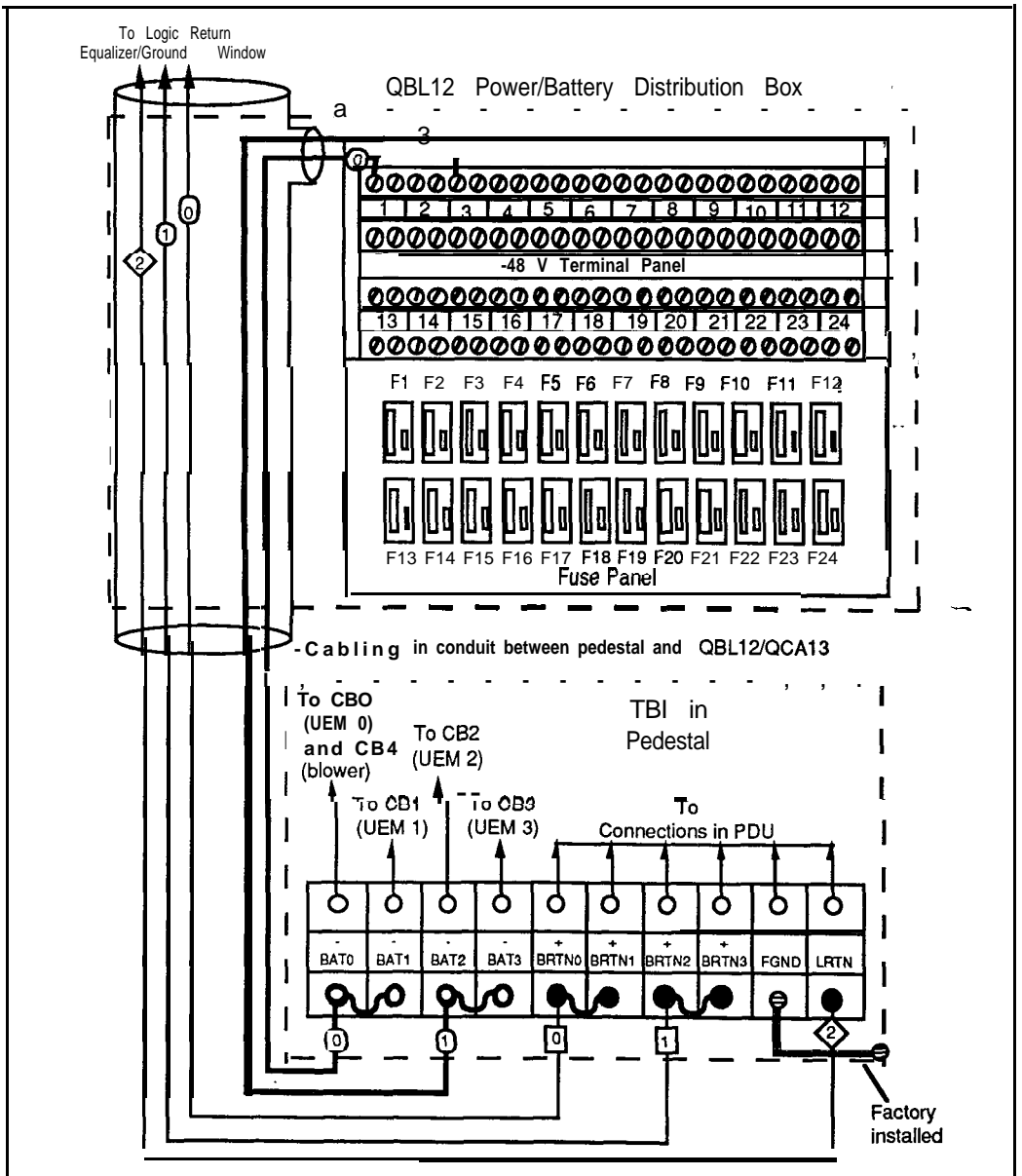

Table 12-1
Pedestal wire gauge requirements with a 30 A feed

Length	Wire AWG		Junction box with single #4 AWG*	Junction box with double #4 AWG*
	Single conduit	Dual conduit		
	8	6	4	4
0 - 10 ft	Yes	Yes	Yes	Yes
0-20ft	Yes	Yes	Yes	Yes
0-30ft	Yes	Yes	Yes	Yes
0-40ft	Yes	Yes	Yes	Yes
0 - 50 ft	Yes	Yes	Yes	Yes
0-60ft	No	Yes	Yes	Yes
0-70ft	No	Yes	Yes	Yes
0-80ft	No	Yes	Yes	Yes
0 - 90 ft	No	No	Yes	Yes
0 -100 ft	No	No	Yes	Yes
0 -200 ft	No	No	No	Yes
200 + ft	No	No	No	No

Note 1: Two 30 A feeds are typically adequate for a full column of 4 modules (two 30 A feed pairs plus Logic return).

Note 2: When using dual conduit, the wires must be run in **BAT/BR** pairs. One pair in one conduit and one pair plus LRTN in the other conduit.

* A single or double run of 4 AWG wire from the distribution point to a junction box near the pedestal. 10 AWG wire is run from the junction box into the pedestal PDU terminal board.

Legend: Yes = Wire size is adequate for the distance.
 No = Wire size has too high a voltage drop and is inadequate for the distance.

Procedure 13: Installing an administration and maintenance terminal

General information

Use this procedure to install an administration and maintenance terminal. In this procedure “terminal” refers to any device which can be connected to a Serial Data Interface (SDI) port, such as modems, teletype devices, or video display terminals.

- 1 Unpack the terminal and dispose of the packing material.
- 2 Place the terminal in its assigned location.
- 3 Install the terminal according to the manufacturer’s instructions.
- 4 Connect one end of an NT8D95AJ cable to the matching **connector** on the terminal. For remote terminal installation, connect the cable to the assigned modem. Figure 13-1 illustrates a typical terminal connection.
- 5** Install the **SDI** circuit pack. **See Procedure 14: Installing a Serial Data Interface (SDI) port**, for complete installation information.
- 6 Connect the other end of the NT8D95 cable to the assigned **SDI port**.

Figure 13-1
Terminal connection diagram

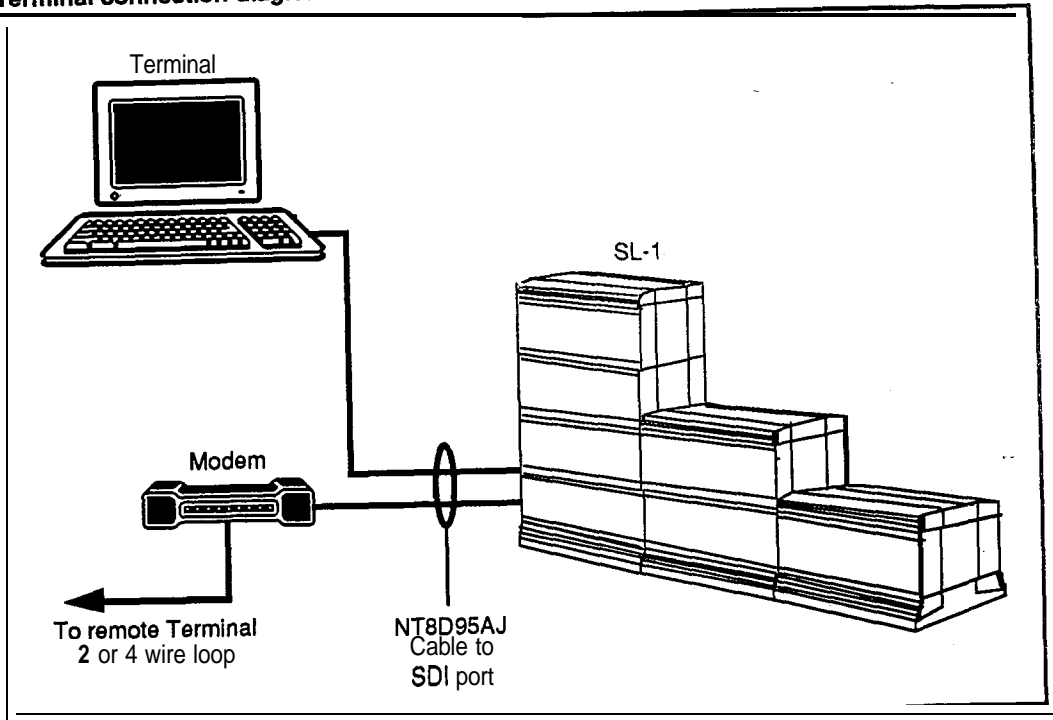

Procedure 14: Installing a Serial Data Interface (SDI) port

General information

Use this procedure to install a Serial Data Interface (SDI) port. The cabling diagrams provided in this procedure do not apply for use of the SDI port in combination with the System Monitor circuit. See Procedure **18: System Monitor cabling**, for SDI/System Monitor cabling.

Installation procedure

- 1 Set the SDI circuit pack faceplate switch to **DIS**.
- 2 Set the the option switches for each port. See **Circuitpack installation and testing** (553-3001-211) for complete SDI switch setting information.
- 3 Insert the SDI circuit pack into its assigned **postion**.
- 4 Cable the SDI circuit pack. Figures 14-1 and 14-2 illustrate SDI cabling for the QPC841 4-port SDI circuit pack and the NT8D41AA SDI paddle board.
- 5 Set the circuit pack faceplate switch to **ENB**. --
- 6 Define each SDI port in the configuration record using LD 17.
- 7 Enable each SDI port. The overlay used to enable and maintain an SDI port depends on the port's application. Some typical SDI applications include:

Terminal and printer ports	LD 37
Call Detail Recording (CDR) links and terminals	LD 42
Automatic Call Distribution (ACD) ports	LD 48

Figure 14-1
Cabling diagram for QPC841 4-Port SDI circuit pack

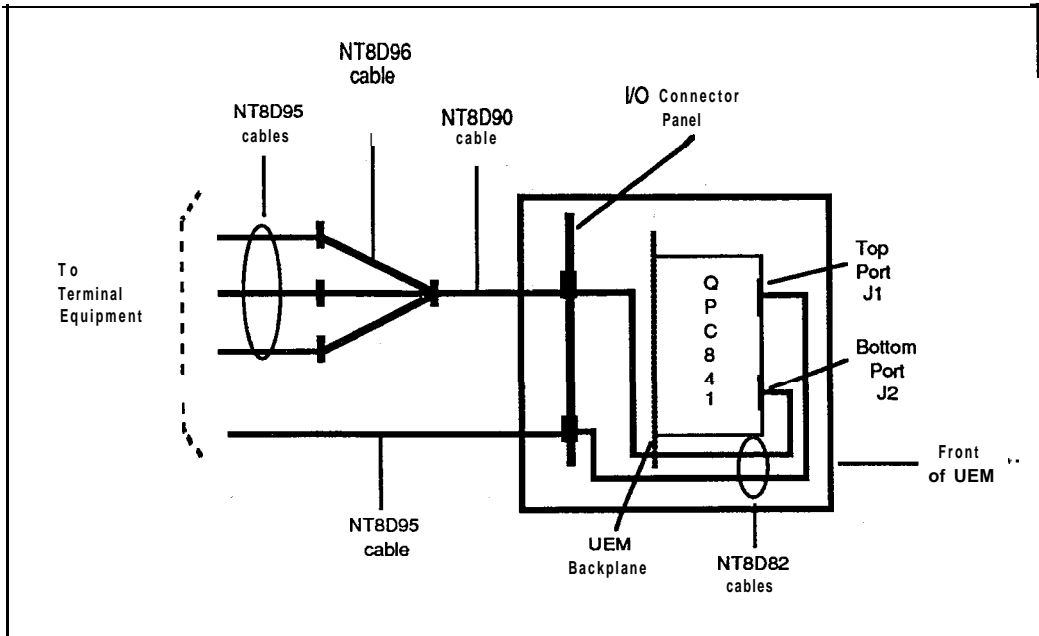
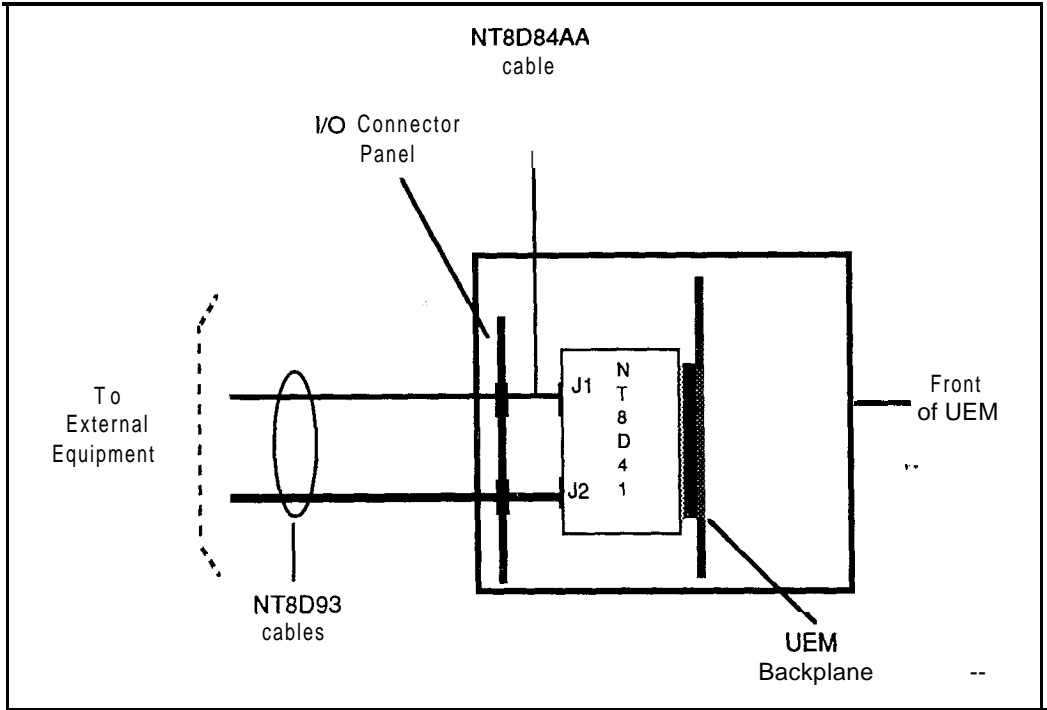

Figure 14-2
Cabling diagram for NT8D41AA SDI paddle board





Procedure 15: Installing a disk drive unit

General information

Use this procedure to add an NT8D68AA Floppy Disk Unit (FDU) or NT8D69AA Multi Disk Unit (MDU) to SL-1 system options 21, 51, 61, and 71. See *Disk drive upgrade procedures* (553-3001-251) for disk drive installation procedures for all other system types.

FDU installation

- 1 Make sure that the correct data cartridge is installed in each QPC742 Floppy Disk Interface (FDI) circuit pack. The ID number on the data cartridge should match the number on the floppy disks provided with the system.
- 2 Set the ENB/DIS switch on each FDI circuit pack to **DIS**.

CAUTION

The NT8D68 Floppy Disk Unit is powered from the NT8D77 cable which connects it to the QPC742 Floppy Disk Interface circuit pack. To prevent an electrical short which might disable the UEM, do not insert the QPC742 circuit pack into its assigned position until **after** you have connected the NT8D77 cable.

- 3 Set option switches 1 and 5 on the FDI to ON.
- 4 Insert the FDU into its assigned position in the UEM.
 - For SL-1 system option 21, the FDU may be installed in any two available consecutive slots, preferably in the area of slots 7 through 9 in the CE portion of the NT8D11 CE/PE module, or in the area of the last three slots in the PE portion of the module.
 - For SL-1 system options 51, 61, and 71, the FDU may be installed in any two available consecutive slots.
- 5 Connect the FDU to each FDI using one NT8D77 cable. This cable runs between the one of the connectors on the FDU faceplate and the connector on the FDI faceplate.

- 6 Insert each FDI into its assigned position in the UEM.
- 7 Set the **ENB/DIS** switch on each FDI circuit pack to **ENB**.
- 8 If the FDU is being added to a working system, test it using Procedure **32: Disk drive test**.

MDU installation

- 1 Make sure **that** the correct data cartridge is installed in each **QPC584E** Mass Storage Interface (MSI) circuit pack. The ID number on the data cartridge should match the number on the floppy disks provided with the system.
- 2 Set the **ENB/DIS** switch on each **MSI** pack to **DIS**.
- 3 Set option switches **1, 4, and 5** on each **MSI** to **ON**.
- 4 Insert the MDU into its **assigned** position in the UEM.
- 5 Connect the MDU to each **MSI** using one **NT8D80** cable. This cable runs between the connector **labelled 0** on the MDU faceplate and the connector **labelled J1** on the **MSI** faceplate.
- 6 Set **the ENB/DIS** switch on each **MSI** pack to **ENB**.
- 7 If the MDU is being added to a working system, test the MDU using **Procedure 32: Disk drive test**.

Procedure 16: Designating the cross-connect terminal

General information

Use this procedure to designate BIX cross-connect terminal blocks.

All terminations for the SL- 1 may be accommodated by **frame** mounted or wall mounted BIX modules and connecting blocks. The layout of the blocks may be varied to meet the requirements of the site. Refer to the following documents for a complete description of the BIX cross-connect system:

BIX In-Building Cross-Connect System Material Description

(631-4511-100)

BIX In-Building Cross-Connect System Planning (63 1-451 1-150)

BIX In-Building Cross-Connect System Material Installation and Servicing (63 1-451 1-200)

Customer premises distribution frame description and installation

(631-451 1-201)

Protection entrance terminal description and installation --

(631-4511-202)

BIX installation and designation

- 1 Install BIX cross-connect blocks according to the installation procedure described *in BIX Installation and Servicing* (631-451 1-200).
 - The BIX module includes 1 **QMBIX10A** mount, 10 **QCBIX1A** connectors, and 5 **QSBIX20A** designation strips. A **QMBIX12E** mount is also available which holds 12 **QCBIX1A** connectors. Figure 16-1 illustrates a wall mounted BIX module.
 - Figure 16-2 illustrates a wall mounted BIX cross-connect terminal.
 - Figure 16-3 illustrates a typical BIX cross-connect terminal layout.
 - Figure 16-4 illustrates the recommended BIX module layout for **NT8D37**, **NT8D13**, and **NT8D11** modules.
- 2 Attach the adhesive designation labels for **500/2500** type telephones to the BIX designation strips. See *BIX Installation and Servicing* (63 1-451 1-200) for information about how to attach the designation labels.
 - Table 16-1 lists part numbers for BIX designation labels.
 - Figure 16-5 illustrates the basic BIX designation label for **NT8D37** Intelligent Peripheral Equipment Modules.
 - Figure 166 illustrates the basic BIX designation label for **NT8D11** -- Common/Peripheral Equipment Modules.
- 3 Attach the labels for trunks on top of the basic labels according to the assignments shown on the work order. The transparent window on the trunk labels allows the card number on the basic labels to be seen.
 - Figures 16-7 through 16-10 illustrate the overlay BIX designation labels for all **NT8D15AA** E&M Trunk modes.
 - Figures 16-11 through 16-13 illustrate the overlay BIX designation labels for all **NT8D14AA** Universal Trunk modes.
- 4 Attach the labels for the **P1**, **P2** (from the **PFTU**), and **P3** (alarm) cable connections.
 - Figure 16-14 illustrates the BIX designation labels for an **NT8D39** type **PFTU**.

- 5 Attach the labels for incoming trunks, sets and riser cables, according to work order.

Figure 16-1
BIX module

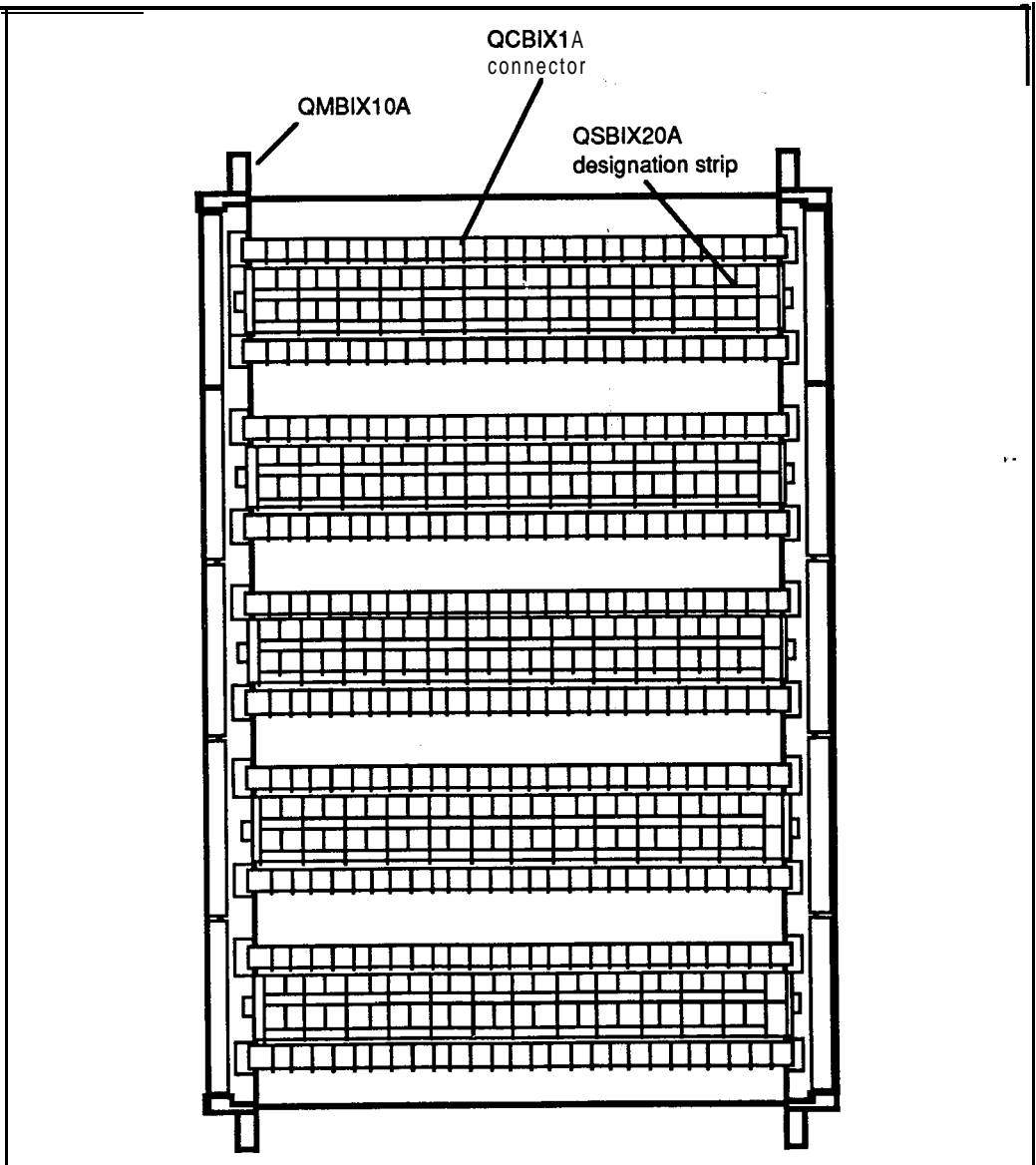

Figure 16-2
Wall mounted BIX cross-connect terminal

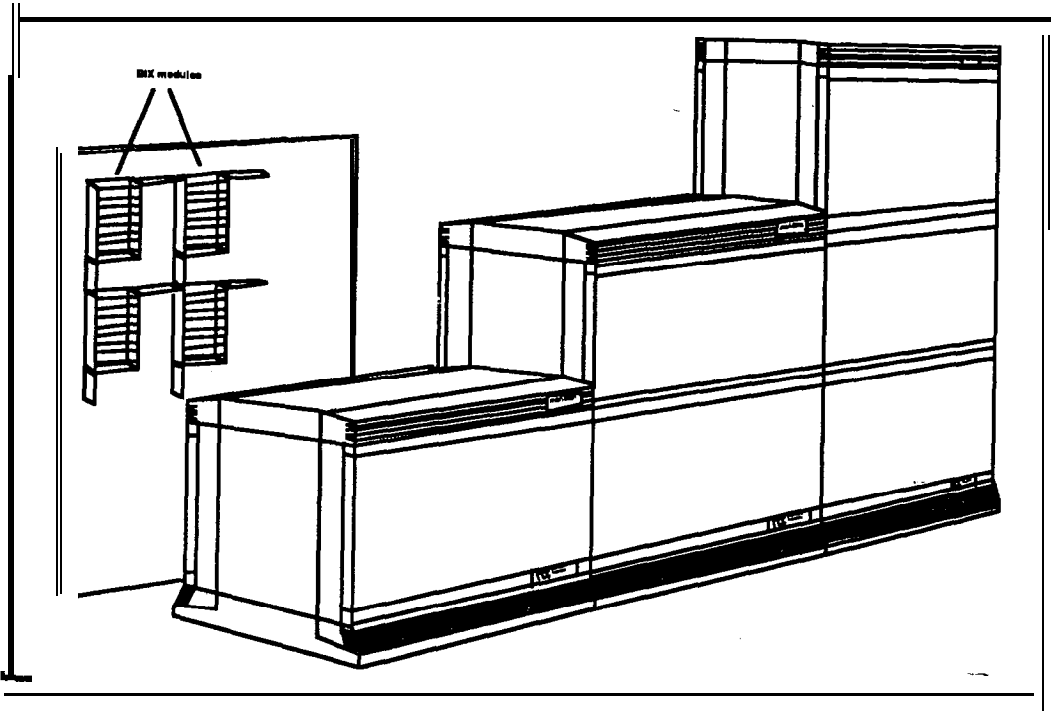

Figure 16-3
Typical wall mounted BIX cross-connect terminal layout

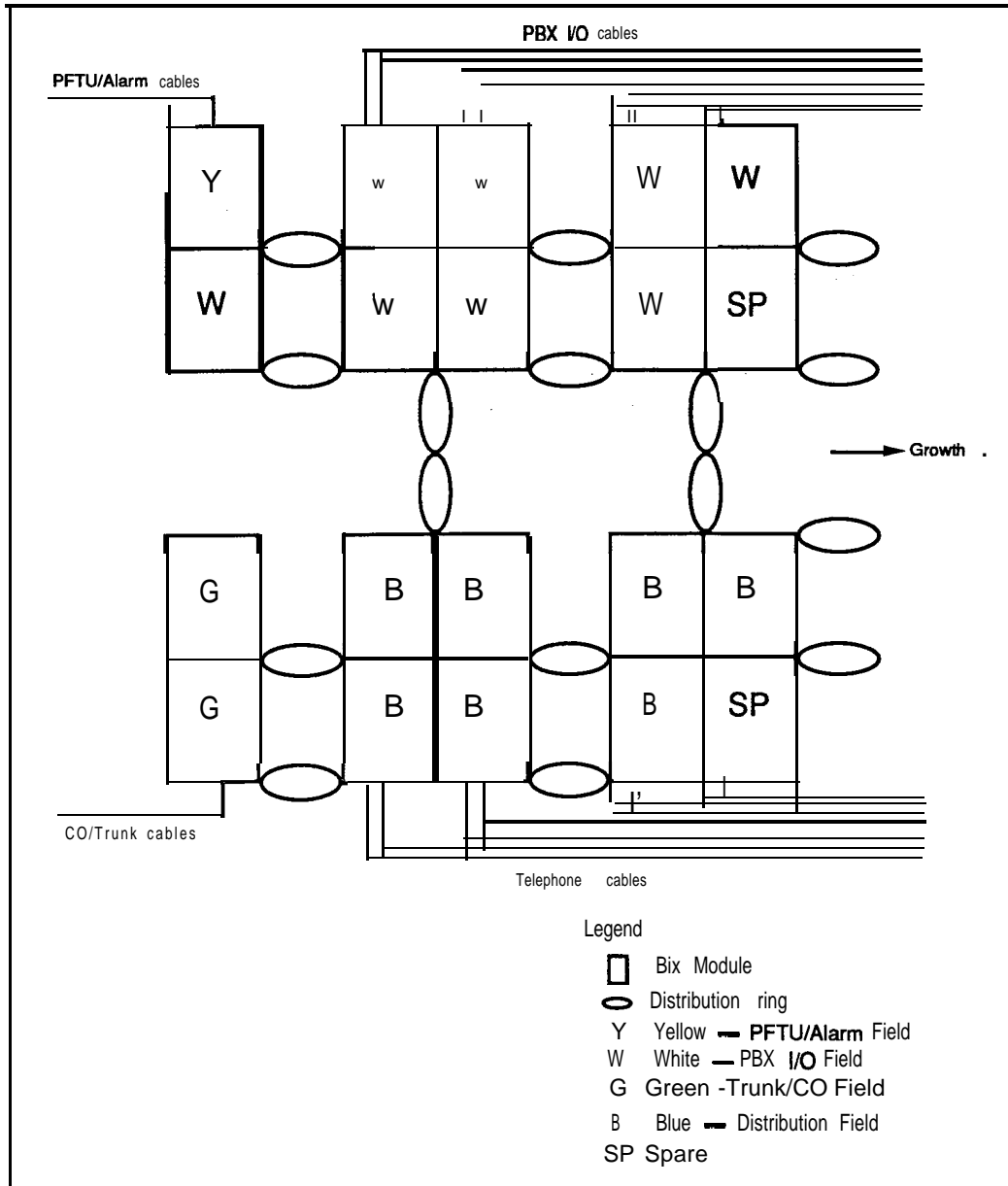

Figure 16-4
Recommended BIX module layout for PE and CE/PE modules

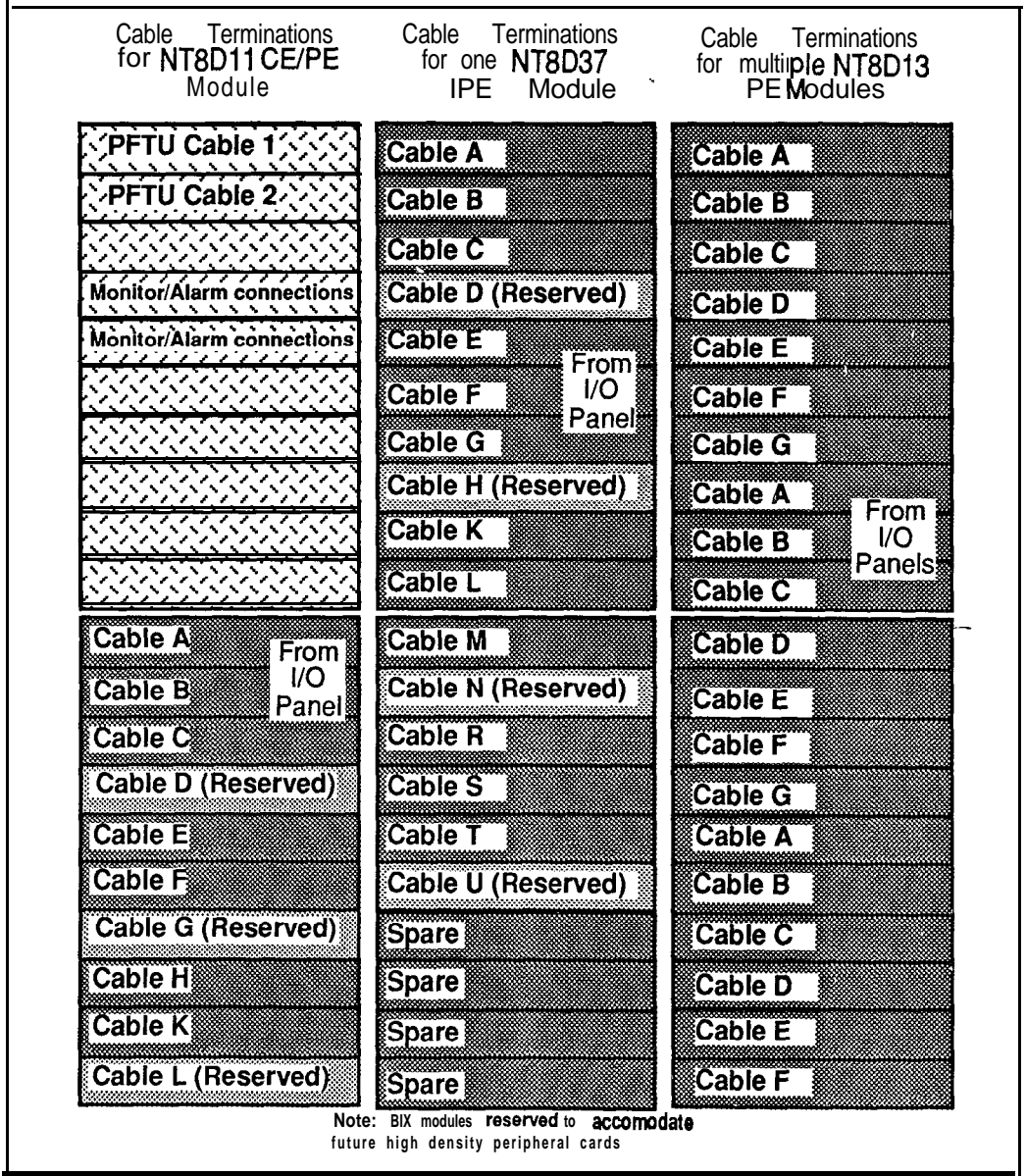

Table 16-1
Order codes for BIX designation strips

Label	Part number
NT8D37 Intelligent Peripheral Equipment Module (basic label)	PO71 1372
NT8D11 Common/Peripheral Equipment Module (basic label)	PO71 1373
NT8D15 E&M Trunk Card (2 wire type 1)	PO71 1379
NT8D15 E&M Trunk Card (2 wire paging)	PO71 1377
NT8D15 E&M Trunk Card (4 wire type 1)	PO71 1374
NT8D15 E&M Trunk Card (4 wire type 2)	PO71 1375
NT8D14 Universal Trunk Card (RAN)	PO71 1376
NT8D14 Universal Trunk Card (paging)	PO71 1378
NT8D14 Universal Trunk Card (CO/FX/WATS and all other modes)	PO71 1380
NT8D39-type Power Fail Transfer Unit (PFTU)	711382

Figure 16-5
Basic BIX designation label for NT8D37 Intelligent Peripheral Equipment Module

A	TR	TR	TR	TR	TR	TR	TR	TR	①	TR	TR	TR	TR	TR	TR	TR	TR	SP	←	→	SP	A				
B	TR	TR	TR	TR	TR	TR	TR	TR	②	TR	TR	TR	TR	TR	TR	TR	TR	TR	TR	TR	TR	TR	TR	②	SP	B
C	TR	TR	TR	TR	TR	TR	TR	TR	③	TR	TR	TR	TR	TR	TR	TR	TR	TR	TR	TR	TR	TR	TR	③	SP	C
E	TR	TR	TR	TR	TR	TR	TR	TR	④	TR	TR	TR	TR	TR	TR	TR	TR	SP	←	→	SP	E				
F	TR	TR	TR	TR	TR	TR	TR	TR	⑤	TR	TR	TR	TR	TR	TR	TR	TR	TR	TR	TR	TR	TR	TR	⑤	SP	F
G	TR	TR	TR	TR	TR	TR	TR	TR	⑥	TR	TR	TR	TR	TR	TR	TR	TR	TR	TR	TR	TR	TR	TR	⑥	SP	G
K	TR	TR	TR	TR	TR	TR	TR	TR	⑧	TR	TR	TR	TR	TR	TR	TR	TR	SP	←	→	SP	K				
L	TR	TR	TR	TR	TR	TR	TR	TR	⑨	TR	TR	TR	TR	TR	TR	TR	TR	TR	TR	TR	TR	TR	TR	⑩	SP	L
M	TR	TR	TR	TR	TR	TR	TR	TR	⑩	TR	TR	TR	TR	TR	TR	TR	TR	TR	TR	TR	TR	TR	TR	⑪	SP	M
R	TR	TR	TR	TR	TR	TR	TR	TR	⑫	TR	TR	TR	TR	TR	TR	TR	TR	SP	←	→	SP	R				
S	TR	TR	TR	TR	TR	TR	TR	TR	⑬	TR	TR	TR	TR	TR	TR	TR	TR	TR	TR	TR	TR	TR	TR	⑭	SP	S
T	TR	TR	TR	TR	TR	TR	TR	TR	⑭	TR	TR	TR	TR	TR	TR	TR	TR	TR	TR	TR	TR	TR	TR	⑮	SP	T

Background color — WHITE

16-10 Designating the cross-connect terminal

Figure 16-6
 Basic BIX designation label for NT8D11 Common/Peripheral Equipment Module

A	TR	TR	TR	TR	TR	TR	TR	TR	①	TR	TR	TR	TR	TR	TR	TR	TR	TR	SP	←								→	SP	A	
B	TR	TR	TR	TR	TR	TR	TR	TR	①	TR	TR	TR	TR	TR	TR	TR	TR	TR	TR	TR	TR	TR	TR	TR	TR	TR	TR	TR	②	SP	B
C	TR	TR	TR	TR	TR	TR	TR	TR	②	TR	TR	TR	TR	TR	TR	TR	TR	TR	TR	TR	TR	TR	TR	TR	TR	TR	TR	TR	③	SP	C
E	TR	TR	TR	TR	TR	TR	TR	TR	④	TR	TR	TR	TR	TR	TR	TR	TR	TR	TR	TR	TR	TR	TR	TR	TR	TR	TR	TR	⑤	SP	E
F	TR	TR	TR	TR	TR	TR	TR	TR	⑤	TR	TR	TR	TR	TR	TR	TR	TR	TR	TR	TR	TR	TR	TR	TR	TR	TR	TR	TR	⑥	SP	F
H	TR	TR	TR	TR	TR	TR	TR	TR	⑦	TR	TR	TR	TR	TR	TR	TR	TR	TR	TR	TR	TR	TR	TR	TR	TR	TR	TR	TR	⑧	SP	H
K	TR	TR	TR	TR	TR	TR	TR	TR	⑧	TR	TR	TR	TR	TR	TR	TR	TR	TR	TR	TR	TR	TR	TR	TR	TR	TR	TR	TR	⑨	SP	K

Background color — WHITE

Figure 16-7
 Overlay BIX designation label for NT8D15AA E&M 2-Wire Type 1 Trunk

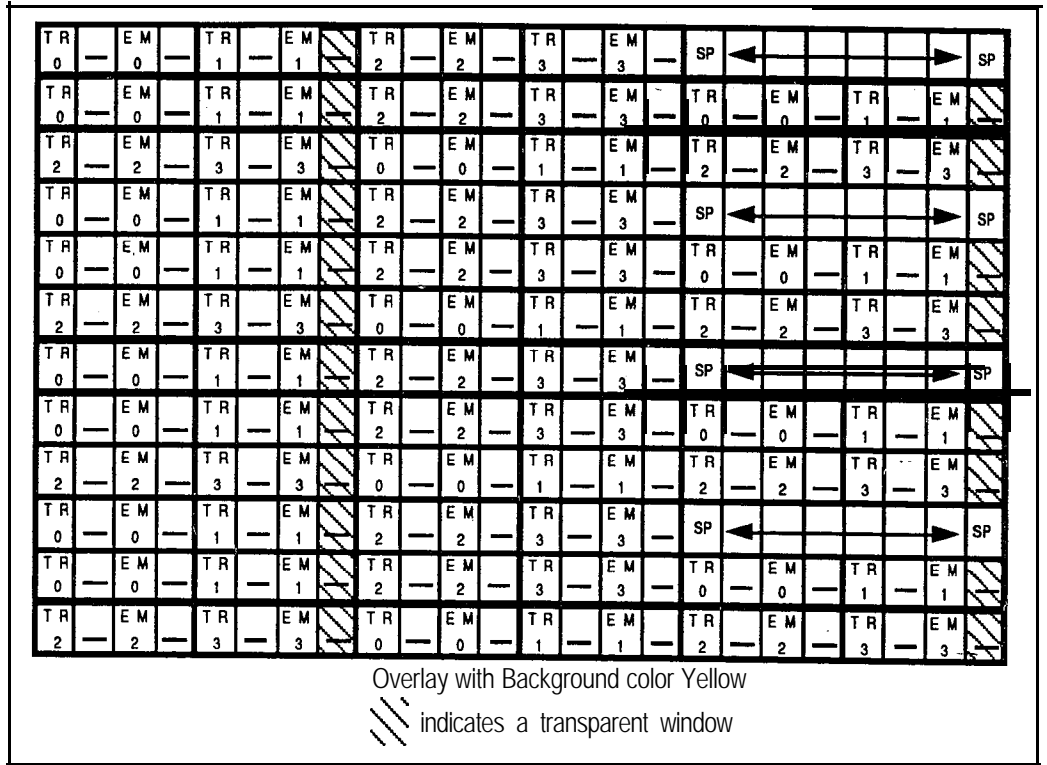

Figure 16-8
 Overlay BIX designation label for NT8D15AA E&M 2-Wire Paging Trunk

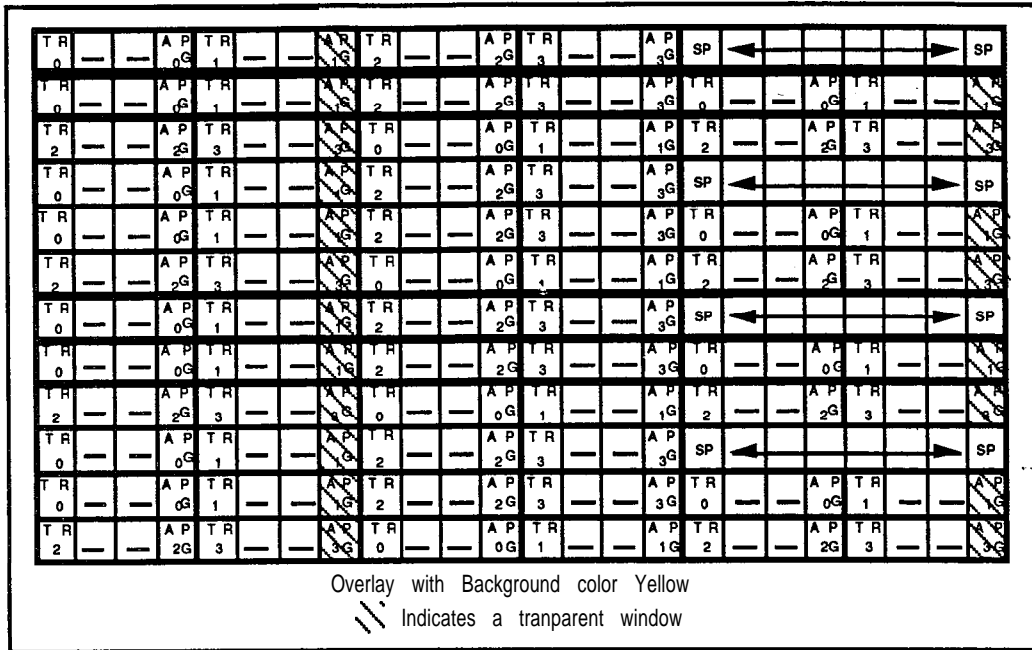

Figure 16-9
 Overlay BIX designation label for NT8D15AA E&M 4-Wire Type 1 Trunk

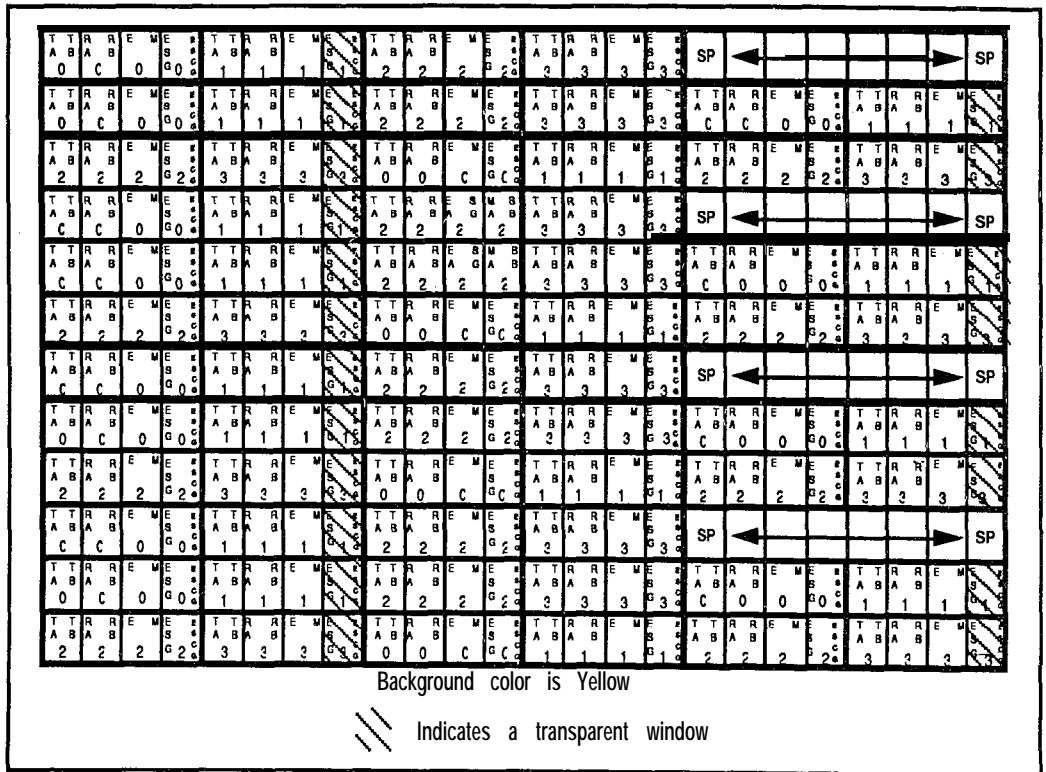

Figure 16-10
 Overlay BIX designation label for **NT8D15AA E&M 4-Wire Type 2 Trunk**

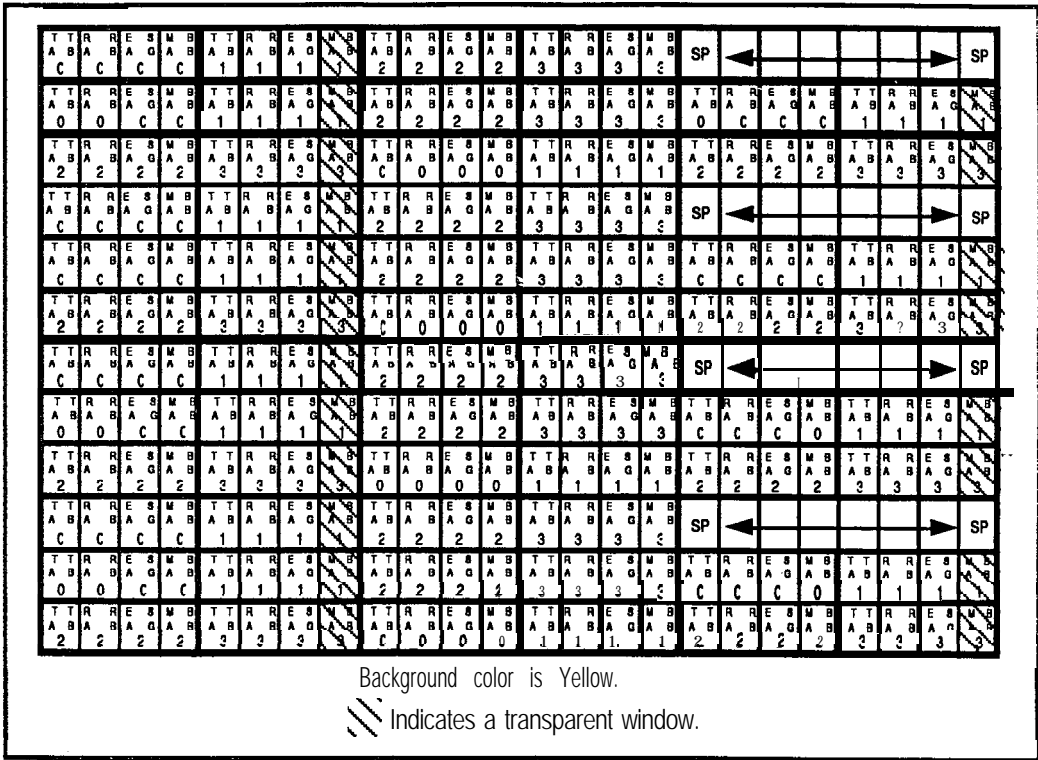

Figure 16-11
Overlay BIX designation label for NT8D14AA Universal Trunk — Paging mode

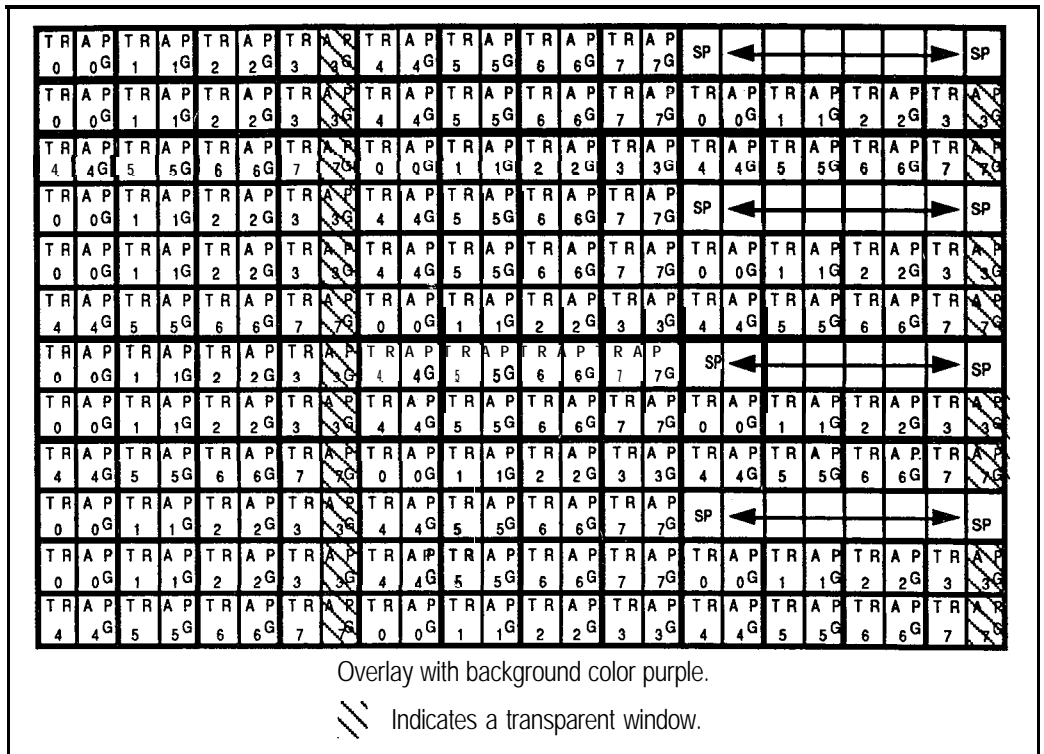

Figure 16-12
 Overlay BIX designation label for **NT8D14AA** Universal Trunk — RAN mods

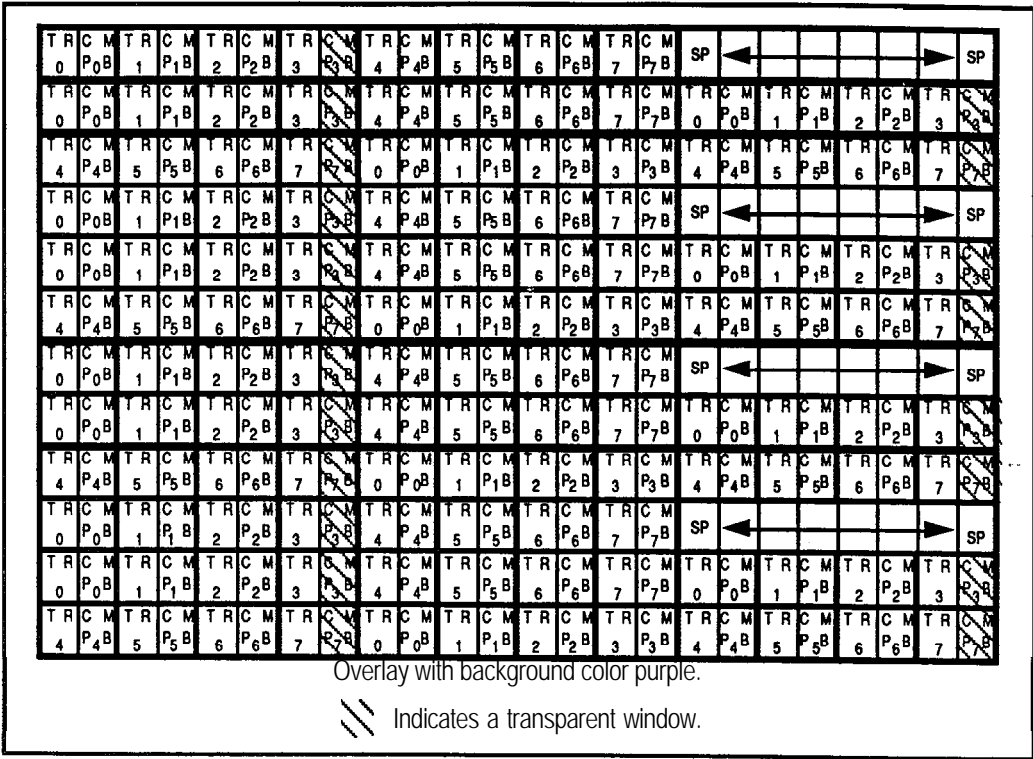

Figure 16-13
 Overlay BIX designation label for NT8D14AA Universal Trunk — CO/FX/WATS and all other modes

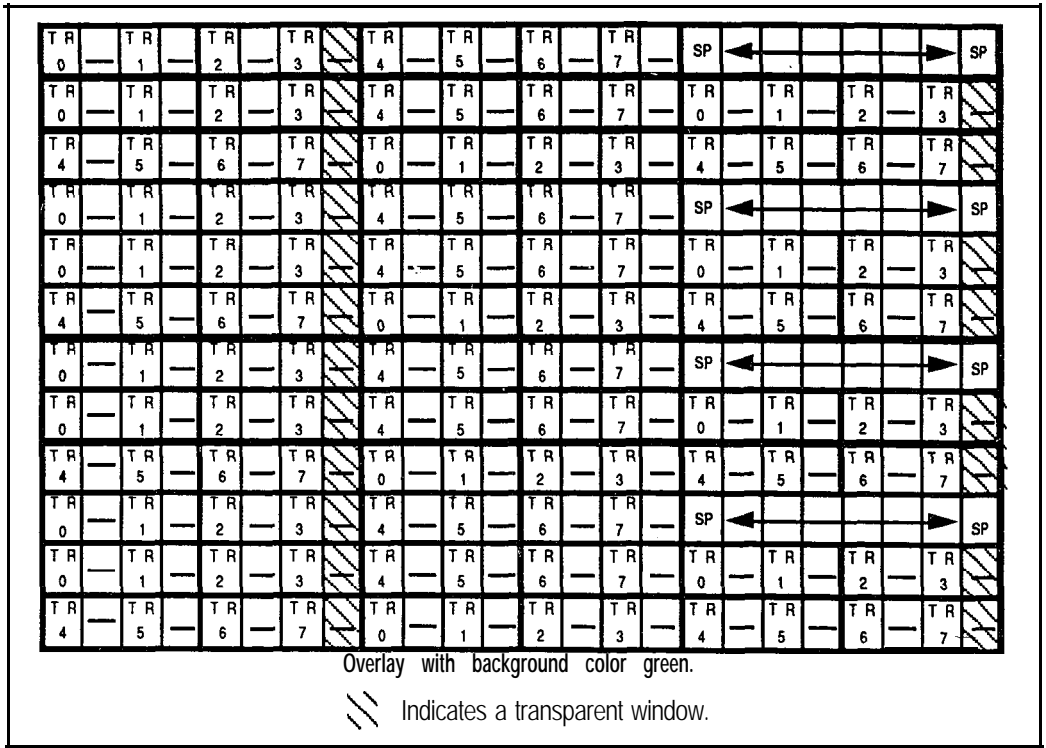
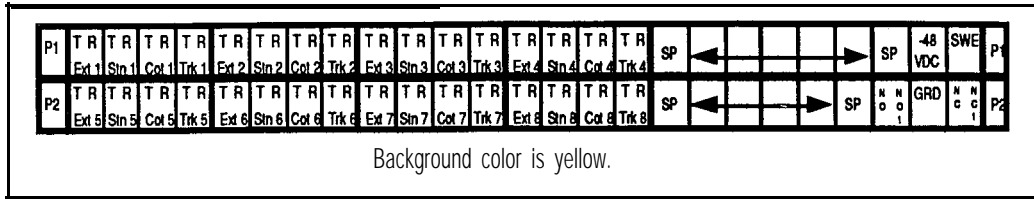

Figure 16-14
BIX designation label for NT8D39-type Power Fail Transfer Unit (PFTU)



Procedure 17: Installing a Power Failure Transfer Unit (PFTU)

General information

Use this procedure to install and connect an NT8D39 type Power Failure Transfer Unit (PFTU).

Connecting blocks capable of accommodating two NE-A25B type cables for each PFTU are required at the cross connect terminal. These blocks should be installed in the space reserved for power failure transfer unit terminations. *See Procedure 25: Connecting trunks and telephones to the PFTU*, for cross-connection diagrams.

Note: On an AC-powered system, the PFTU requires a -48 V dc power supply. On a DC-powered system, the PFTU requires a -48 V dc fused output from the power plant.

Installing PFTUs

- 1 Remove the PFTU from its container and mount it on the wall near the cross connect terminal.
- 2 Perform this step for DC powered systems only.

Using a fused output from the QBL15, QBL12 or QCA13, connect one #12 - 14 AWG to a wall mounted three position terminal block (Northern Telecom part number A0329007) located next to the MDF. Connect the -48 V dc to the MDF using one #24 AWG. The power then can be cross-connected to the PFTU as shown in Table 17-1. The MDF ground is the ground for the PFTU. Use the following fuses:

 - 1 PFTU 1.33A fuse
 - 2 PFTU 3A fuse
 - 3 PFTU 4A fuse
- 3 Install two NE-A25B type cables from connectors P1 and P2 on the front of the PFTU to the assigned connecting blocks at the cross connect terminal. The cables should be labelled P1 and P2 at both ends for easy identification.

- 4 Install the designation strips for the PFTU on the connecting blocks (if not previously installed). If designation strips are not provided, mark the connections on cable **P1** as shown in Table 17-1.
- 5 Install the connections on cable **P1** as shown in Table 17-1.

Note: The PFTU requires -48 V dc power supply.

The green LED should light when the power supply is connected to the PFTU. The red LED should alternate between on and off each time the button on the front of the PFTU is pressed. When the red LED is on, the PFTU is in transfer mode; when the red LED is off and the green LED is on, the PFTU is not in transfer mode.

Table 17-1
Connections on Cable P1 from PF U

Pair	Color	Description	Connection
24T	V-BR	Logic Input	LFBN from NT8D46AH alarm cable (J3)
24R	BR-V	Switch Input	TC on cable to attendant console
25T	v-s	Ground	GND MDF from NT8D46AH alarm cable (J3)
25R	s-v	Voltage	-48 V dc power supply

Procedure 18: ‘Installing System Monitor cabling

General information

Use this procedure to install cabling for **NT8D22** and **NT7D15** System Monitors.

The **NT8D22** System Monitor is located inside the rear of each pedestal in system options **21, 51, 61,** and **71**

The **NT7D15** System Monitor is located on the backplane of the **NT8D11 CE/PE** module in system option **21A**.

In system options **21, 51, 61,** and **71**, the **NT8D22** System Monitor in the main equipment column (the column equipped with CPU 0) is designated as the master System Monitor. System monitor assemblies located in the remaining columns are designated as slave system monitors.

In system option **21A**, the **NT7D15** System Monitor is installed in one of the four backplane slots at the rear of the **ND8D11 CE/PE** Module.

Each **NT8D22** System Monitor is equipped with option switches used to indicate whether it is a master or a slave, the number (address) of the column in which it is located, and other options. See the chapter “Circuit pack application examples” in ***Circuit pack installation and testing*** (553-3001-211) for a detailed description of System Monitor configurations and associated switch settings.

An **SDI** port located in the main equipment column is required for operation of the **NT8D22** System Monitor. For instructions on installing **SDI** ports, see ***Procedure 14: installing a Serial Data Interface (SDI) port***.

NT8D22 System Monitor cabling installation

- 1 Set the option switches for each System Monitor being installed.

To set the switches, remove the rear pedestal grill, loosen the two retaining screws securing the System Monitor to the power distribution unit, and remove the System Monitor circuit pack. See Figure 18-1. The switches are located on the component side of the assembly.

- See the chapter “Circuit pack application examples” in **Circuit pack installation and testing** (553-3001-211) for System Monitor switch setting information.

- Set the baud rate for **the SDI port associated with the master System Monitor** to 1200 baud.

- 2 Perform this step for system options **21, 51** and 61 only.

Remove the backplane access plate from the I/O panel at the rear of the CPU module.

Connect the master System Monitor to an **SDI** circuit pack. Use an **NT8D46AG** cable if connecting to an **NT8D41AA SDI Paddle Board**. Use an **NT8D46AD** cable when connecting to any other **SDI** circuit pack. See Figure 18-2.

Connect the small portion of the **NT8D46** cable assembly to the assigned **SDI** port. --

- 3 Perform this step for system option 71 only.

Remove the backplane access plate from the I/O panel at the rear of the module containing CPU 0 and the network module directly above it.

Connect the master System Monitor in CPU module 0 to Slave System Monitor #1 in CPU module 1 using an **NT8D46AS** cable. See Figure 18-3.

Connect the small portion of **the NT8D46AD** cable assembly in the Network module directly above the module containing CPU 0 to the assigned **SDI** port. See Figure 18-4.



- 4 Perform this step for multi-column installations only.

Beginning with the master System Monitor, connect an **NT8D46AL** (if columns are adjacent) or an **NT8D46AP** (if columns are not adjacent) cable from connector **J6** to connector **J5** on the System Monitor of the neighboring column. Repeat this step until all System Monitor assemblies are connected in series. See Figure 18-5.

- 5 Perform this step for DC powered systems only.

Connect one of the following cables from connector **J4** on each System Monitor to the DC power distribution box, See Figure 18-5.

- For a **QBL15**, use an **NT8D46AT** alarm cable. See Table 18-2 for the terminating sequence and color assignments.
- For a **OBL12**, use an **NT8D46AW** alarm cable. See Table 18-3 for the terminating sequence and color assignments.
- For a **QCA13**, use an **NT8D46AV** alarm cable. See Table 18-4 for the terminating sequence and color assignments.

- 6 Perform this step only for systems equipped with an **Uninterruptable Power Supply (UPS)** unit.

Connect one of the following cables from connector **J4** on each **System Monitor** to the UPS. See Figure 18-5.

- For a Best Inc. UPS, use an **NT8D46AJ** alarm cable.
- For an Exide UPS, use an **NT8D46AQ** alarm cable.
- For an Alpha UPS, use an **NT8D46AU** alarm cable.

- 7 Install an **NT8D46AH** alarm cable from connector **J3** on each System Monitor to the cross connect terminal. See Figure 18-5.

- 8 Terminate and designate the cable on its assigned connecting block in the area reserved for alarm connections. See Table 18-1 for the terminating sequence and color assignments.

Figure 18-1
NT8D22 System Monitor location

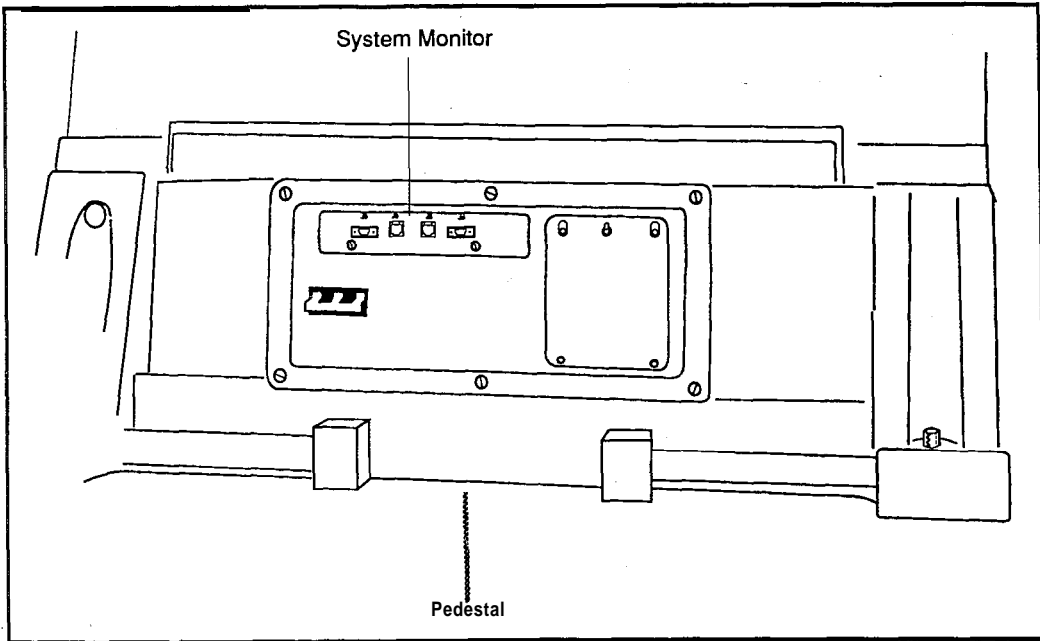

Figure 18-2
Master System Monitor to SDI cabling for system options 21, 51 and 61

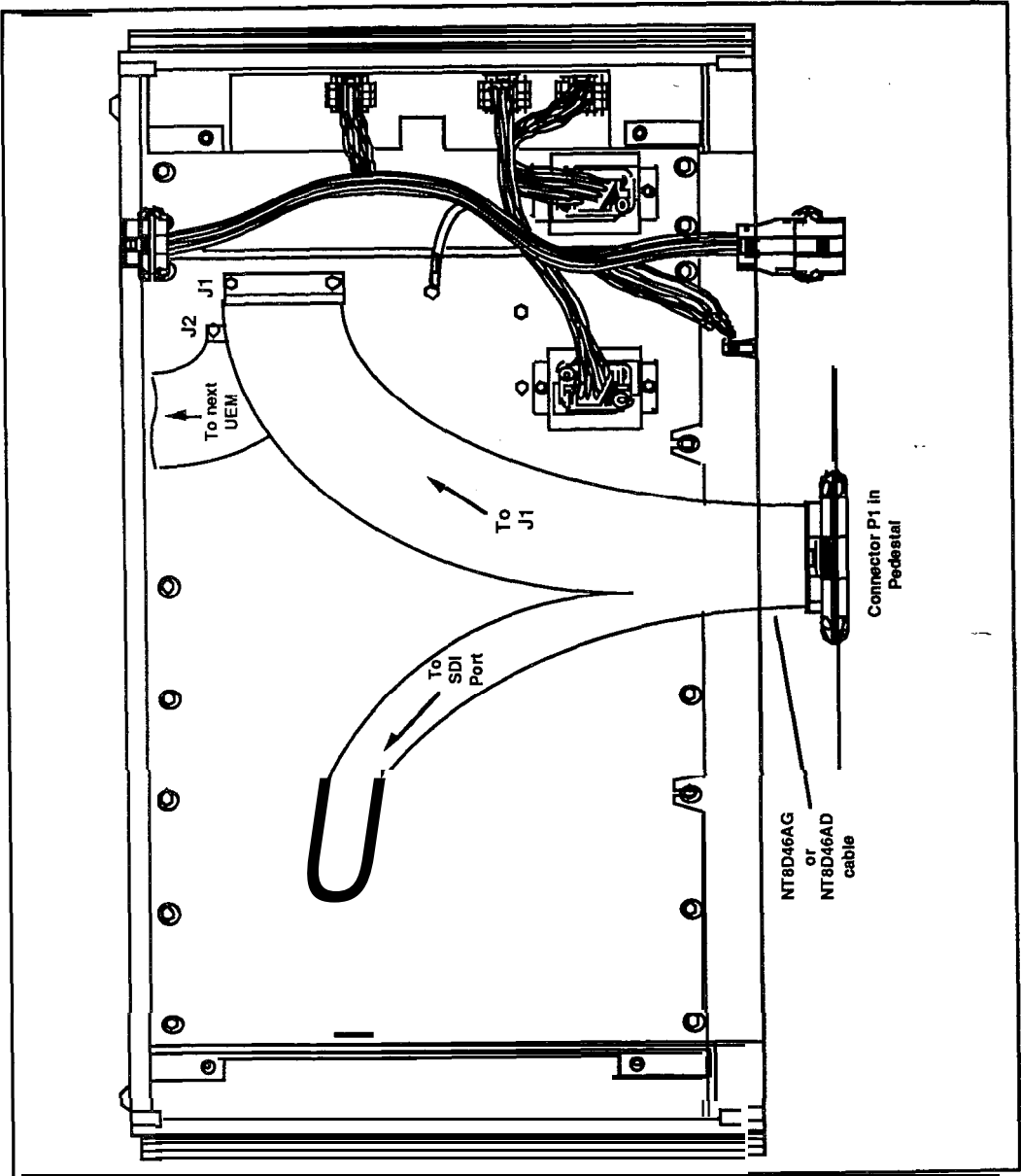

Figure 18-3
Master System Monitor to Slave System Monitor #1 cabling for system option 71

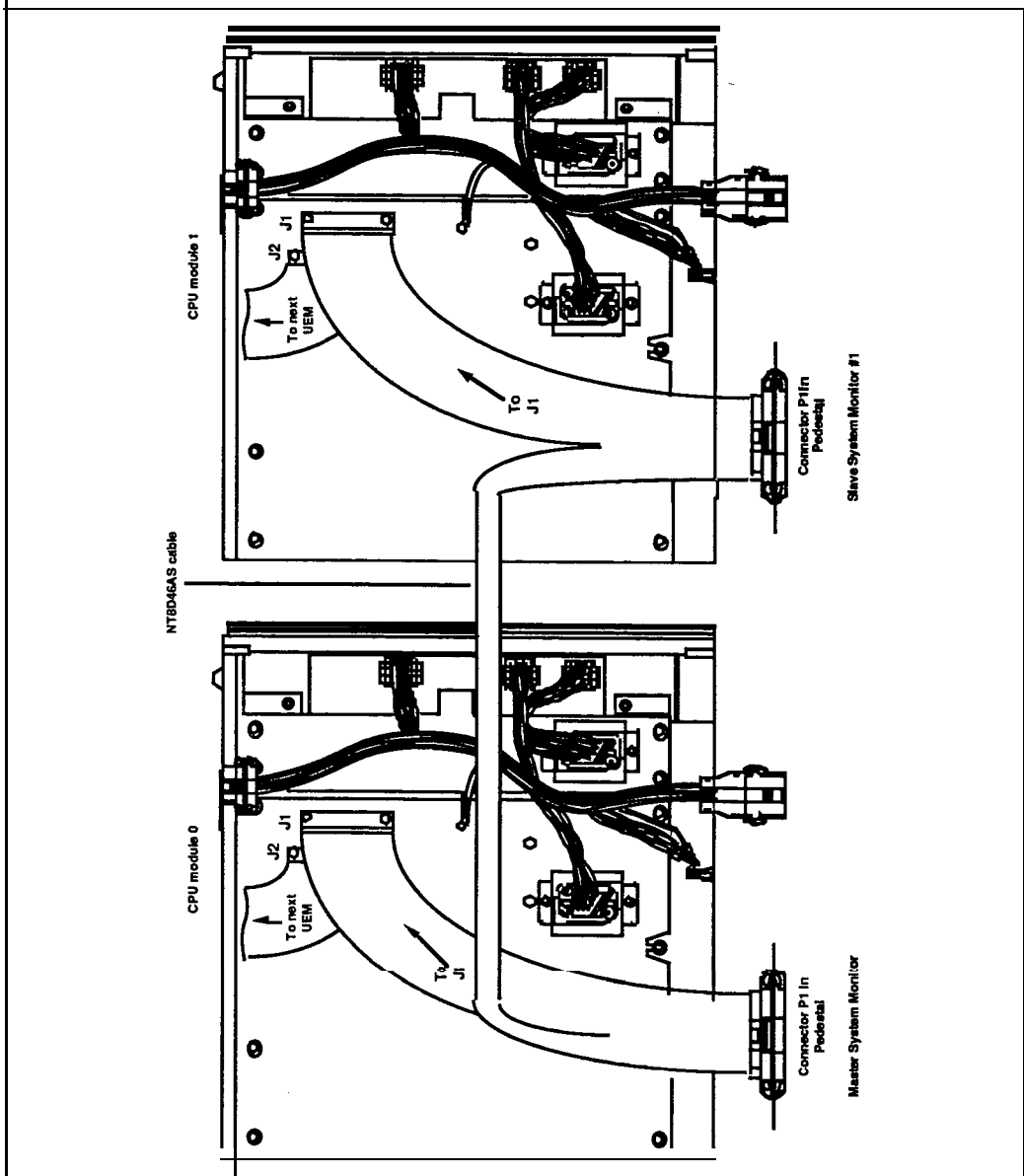

Figure 18-4
Master System Monitor to SDI cabling for system option 71

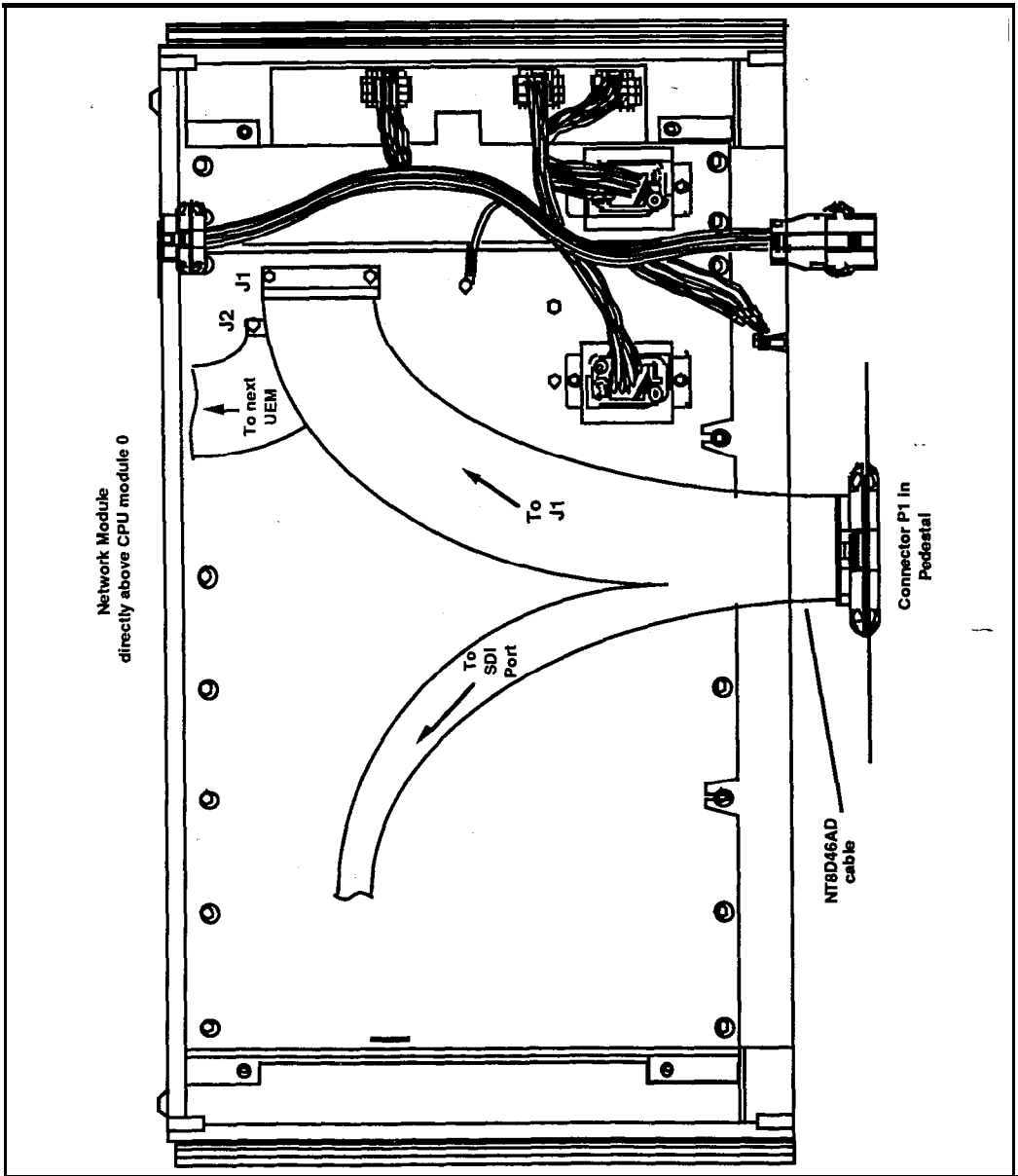

Figure 18-5
NT8D22AB System Monitor connections for multi-column system

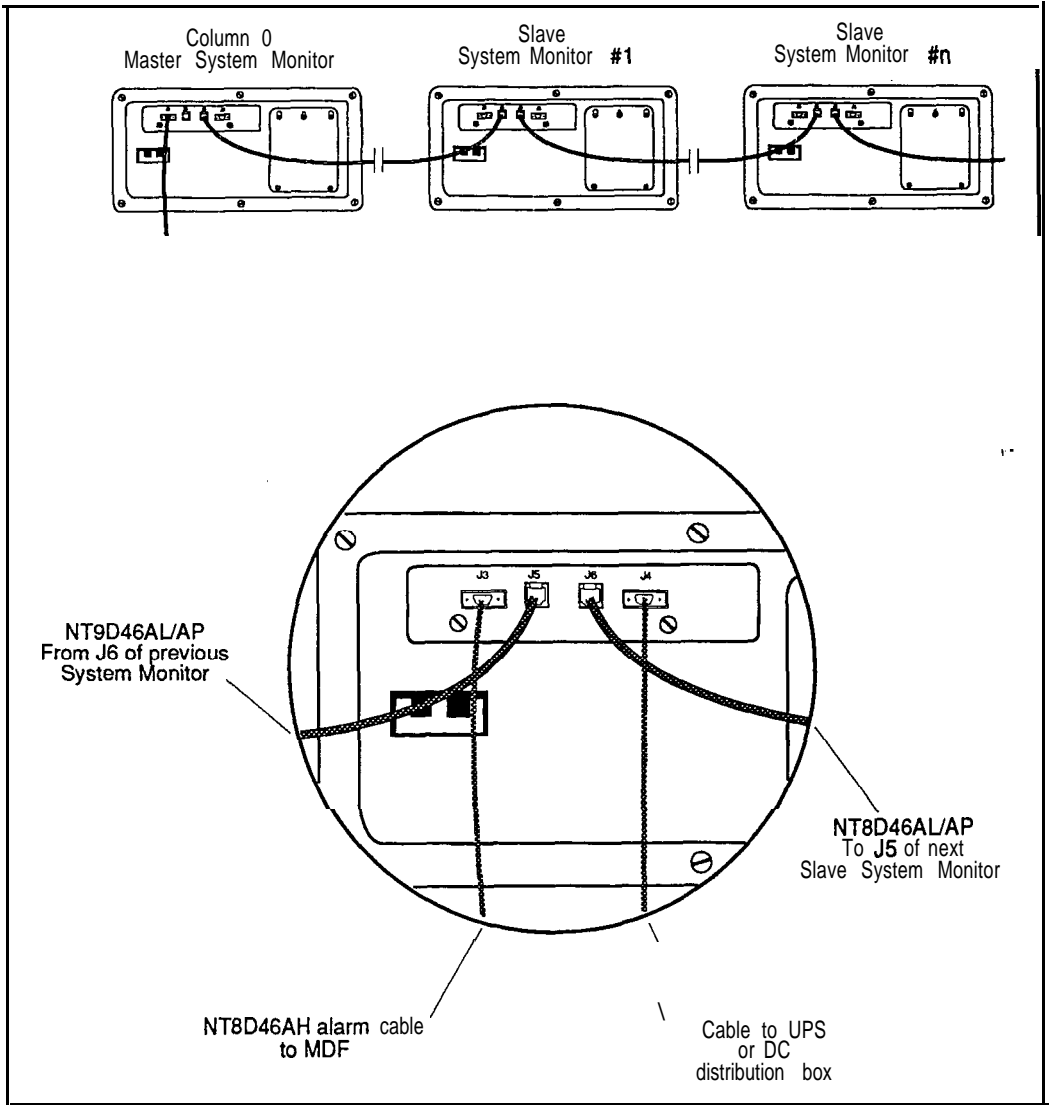

Table 18-1
Pin assignments for NT8D46AH alarm cable (J3)

Pin Number	Color	Designation at MDF
1	Black	REMALMA
2	Red	REMALMB
3	White	CE-SYSLT
4	Green	MDF 0/-48
5	Orange	CEALMIN
6	Blue	SYSLTIN
7	Brown	LFBEN
8	Yellow	LFBENR
9	Violet	GND

Table 18-2
Pin assignments for NT8D46AT alarm cable (J4)
System Monitor to QBL15

Pin Number	Color	Designation
1	Black	DCON 0
2	Red	DCON 1
3	White	DCON 2
4	Green	DCON 3
5	Orange	Alarm
6	Blue	Not used
7	Brown	Trip
8	Yellow	Not used
9	Violet	Not used

Table 18-3

**Pin assignments for NT8D46AW alarm cable (J4)
System Monitor to QBL12**

Pin Number	Color	Designation
1	Black	D CON 0
2	Red	Not used
3	White	Not used
4	Green	Not used
5	Orange	Alarm
6	Blue	Not used
7	Brown	Trip
8	Yellow	Not used
9	Violet	Not used

Table 18-4

**Pin assignments for NT8D46AV alarm cable (J4)
System Monitor to QCA13**

Pin Number	Color	Designation
1	Black	Not used
2	Red	Not used
3	White	Not used
4	Green	Not used
5	Orange	Alarm
6	Blue	Not used
7	Brown	Trip
8	Yellow	Not used
9	Violet	Not used

NT7D15 System Monitor cabling installation

- 1** Remove the rear cover of the **CE/PE** Module.
- 2** Loosen the four retaining screws and remove the backplane access cover.
- 3** Insert the **NT7D15** System Monitor into one of the slots at the rear of the **CE/PE** Module, as illustrated in Figure 18-6.
- 4** Connect an **NT8D40BJ** cable from connector **P1** on the System Monitor to connector **J1** on the backplane.
- 5** Connect an **NT8D84AA** cable from connector P2 on the System Monitor to an available connector on the I/O panel.
- 6** Connect an **NT8D40BK** cable from connector P3 on the System Monitor to connectors C1 and C2 on the circuit breaker assembly in the pedestal.

Figure 18-6
NT7D15 System Monitor location

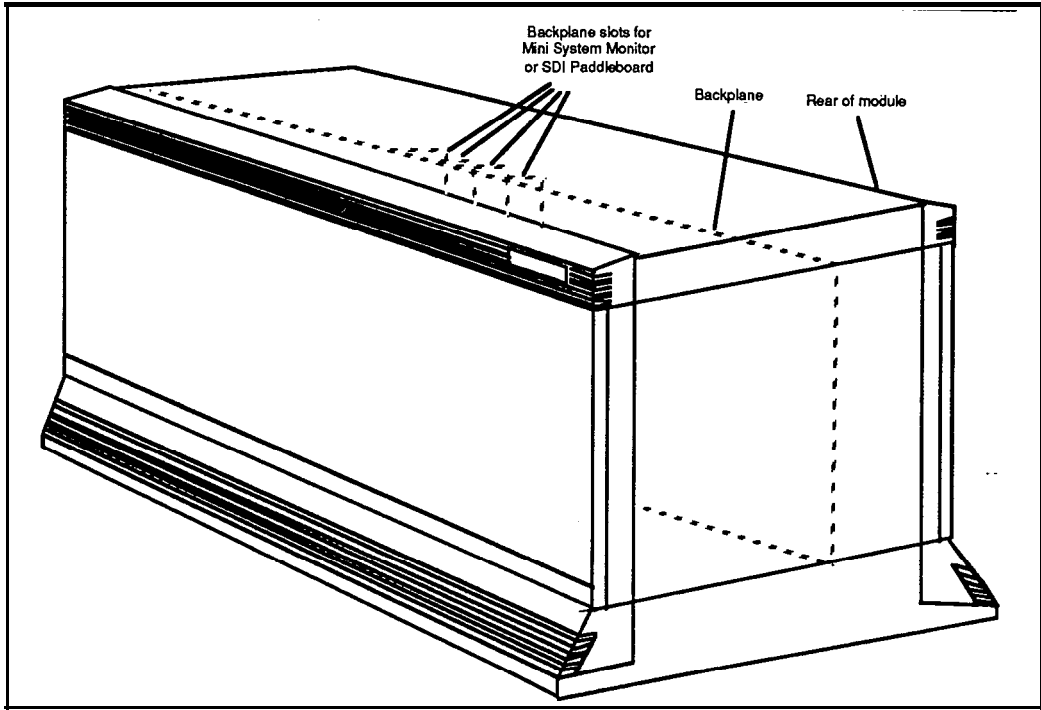

Procedure 19: Cabling Common Equipment in system option 61

General information

Use this procedure to install Common Equipment cabling for an SL-1 system option 61.

The SL-1 system option 61 consists of two **NT6D39AA** CPU/Network (CPU/NET) modules and one or more Peripheral Equipment (**PE**) modules, as illustrated in Figure 19- 1.

Figure 19-1
System option 61 dual CPU/full network group configuration

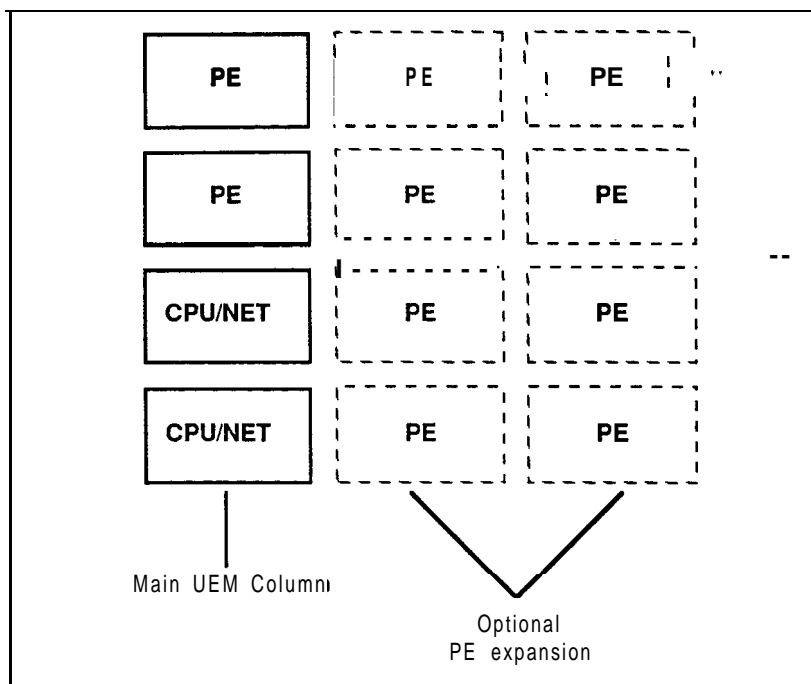

Internal cable routing

Cables within a column or between adjacent columns are routed inside the **UEMs** through cable troughs (See Figure 19-2) in the following manner:

- Horizontally across the front and rear of **the** card cage when cables remain inside the DEM.
- Horizontally from the front to the rear of the UEM through the cable trough on the right side of the **UEM**.
- Vertically in the channel on the right side of the card cage (viewed from the front of the UEM).
- Through the square holes near the rear of the UEM when cables must exit an equipment column.

CAUTION

Due to the limited space available and the effects of **EMI/RFI** noise which may be generated by the power supply unit, do not route cables from front to rear on the left side of the card cage. Route these cables through the space provided on the right side of the DEM.

Figure 19-2
Front view of UEM cable routing troughs and access channels

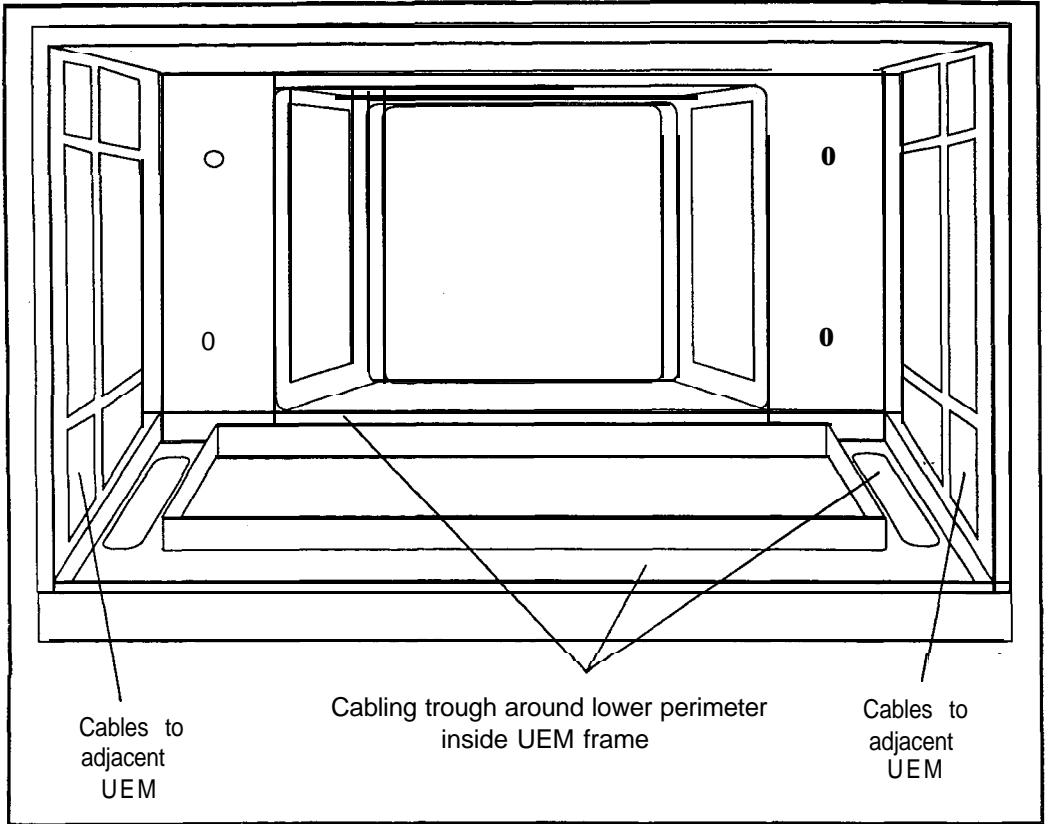

Cable installation

- 1 Connect the **QPC581** Changeover & Memory Arbitrator (CMA) circuit pack in CPU/Network module 0 to **the** corresponding CMA circuit pack in CPU/Network module 1 with one **NT8D85** cable and 1 **NT8D80** cable.

Figure 19-2 illustrates the cable routing troughs in each UEM.

Figure 19-3 illustrates the CPU/NET module front panel, showing the locations of the CMA circuit pack connectors.

- 2 Connect the **QPC441 3-Port Extender (3PE)** circuit pack in CPU/NET module 0 to the corresponding 3PE circuit pack in CPU/NET module 1 with two **NT8D80AD** cables.

Figure 19-3 illustrates the CPU/NET module front panel, showing the locations of the 3PE circuit pack connectors.

- 3 Connect network half-group 0 to network half-group 1 with two **NT8D99AB** cables.

Figure 19-4 illustrates the **NT6D39** CPU/NET module backplane, showing the locations of the connectors.

- 4 Seat and secure all connectors.

Figure 19-3
 Connection of CMA and 3PE circuit packs on NT6D39 CPU/Network modules

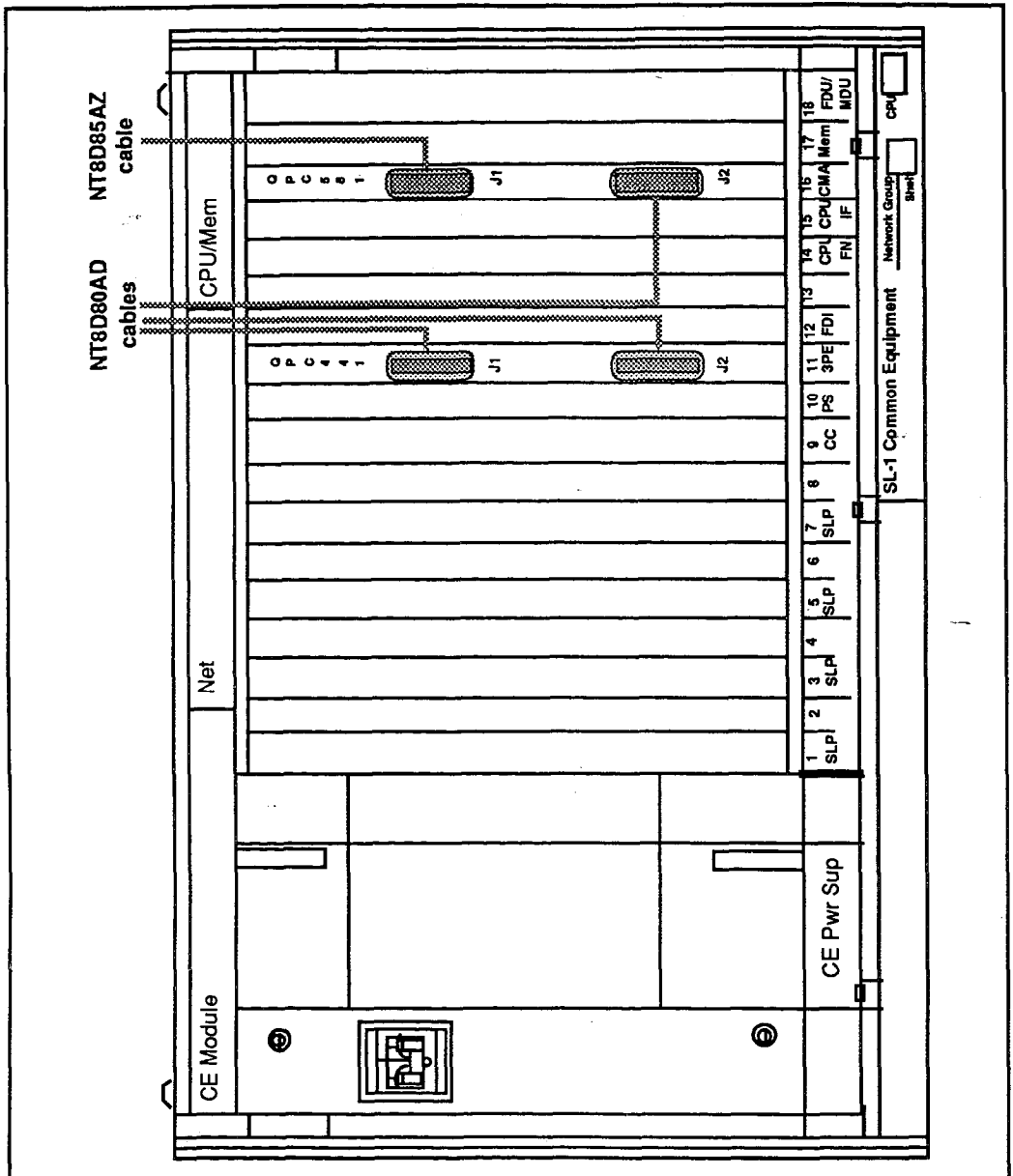
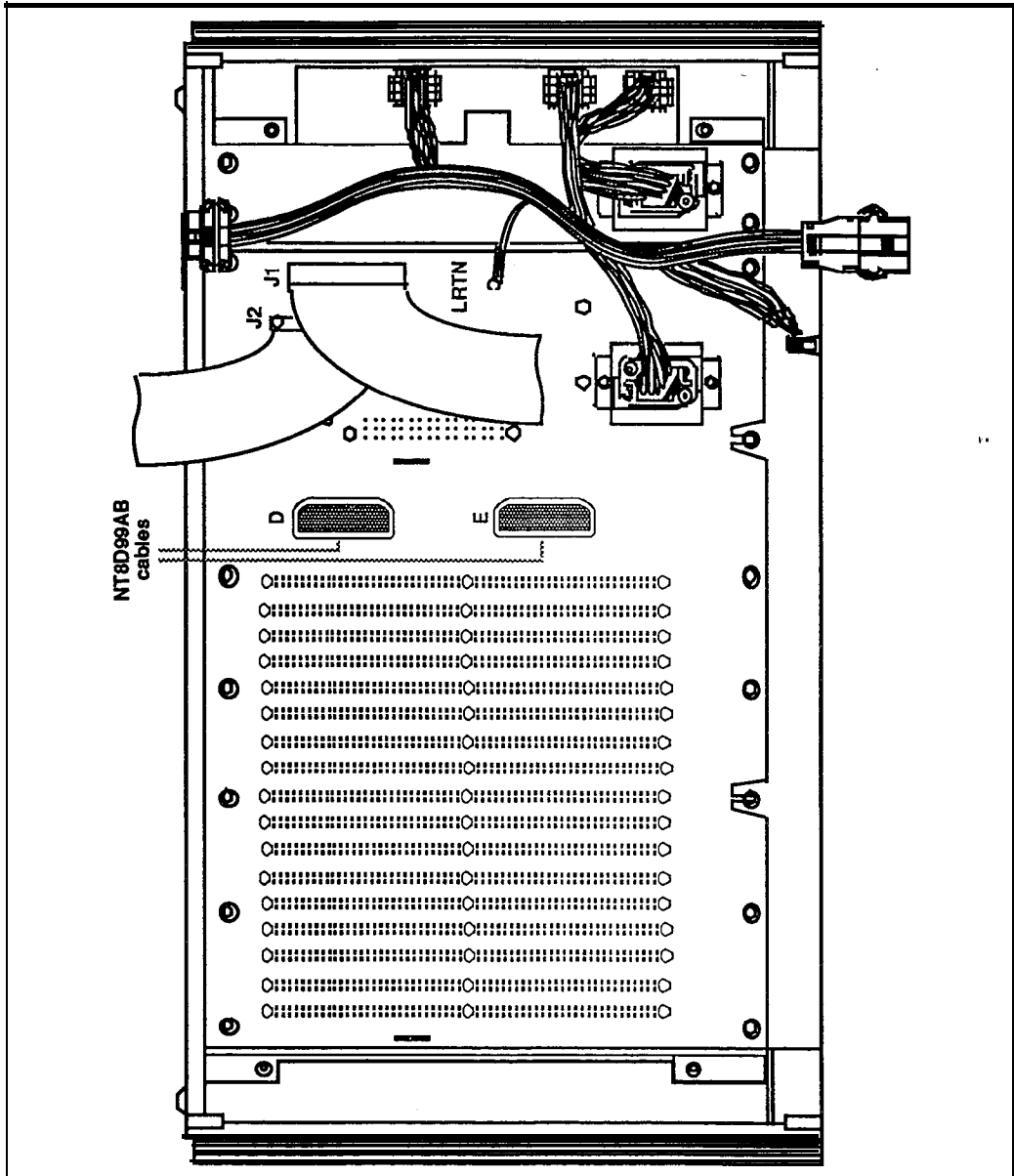

Figure 19-4
Location of D and E connectors on NT6D39 CPU/Network module



Procedure 20: Cabling Common Equipment in system option 71 systems

General information

Use this procedure to install Common Equipment cabling for an SL- 1 system option 71.

The SL-1 system option 71 consists of two NT8D34 CPU modules, two to ten NT8D35 Network modules, one NT8D36AA InterGroup module, and NT8D37 or NT8D13 Peripheral Equipment (PE) modules, as illustrated in Figure 20- 1.

Figure 20-1
System option 71 multiple network group configuration

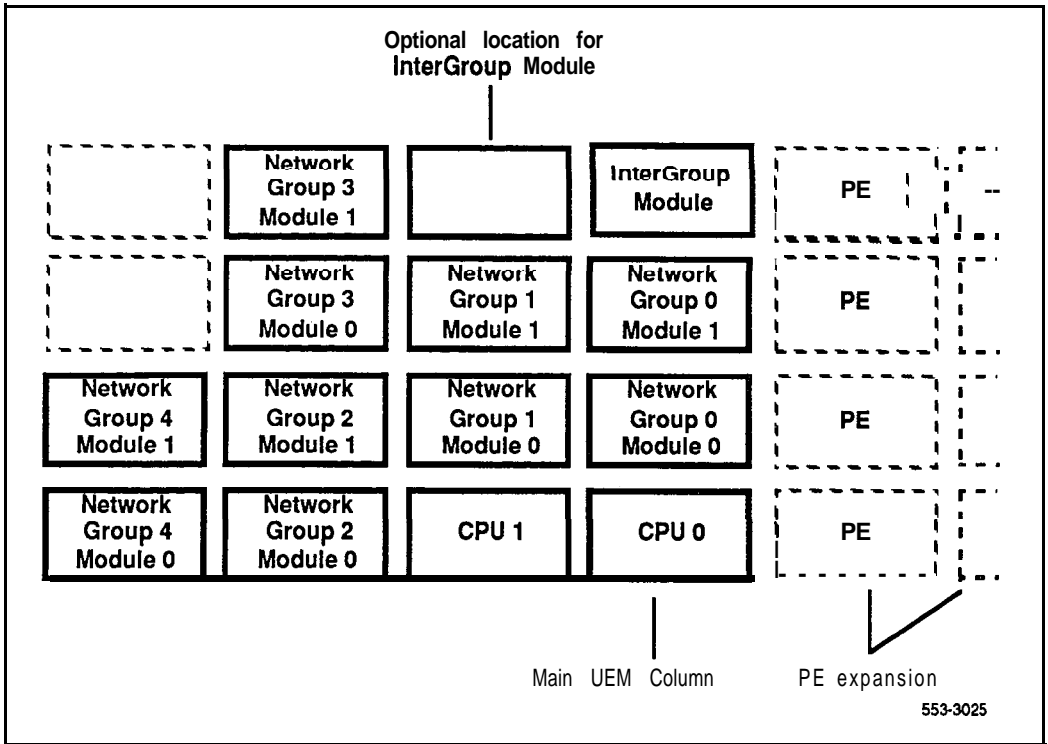

Internal cable routing

Cables within a column or between adjacent columns are routed inside the UEMs through cable troughs (See Figure 20-2) in the following manner:

- Horizontally across the front and rear of the card cage when cables remain inside the UEM.
- Horizontally from the front to the rear of the UEM through the cable trough on the right side of the UEM.
- Vertically in the channel on the right side of the card cage (viewed from the front of the UEM).
- Through the square holes near the rear of the UEM when cables must exit an equipment column.

CAUTION

Due to the limited space available and the effects of **EMI/RFI** noise which may be generated by the power supply unit, do not route cables from front to rear on the left side of the card cage. Route these cables through the space provided on the right side of the UEM.

Figure 20-2
Front view of UEM cable routing troughs and access channels

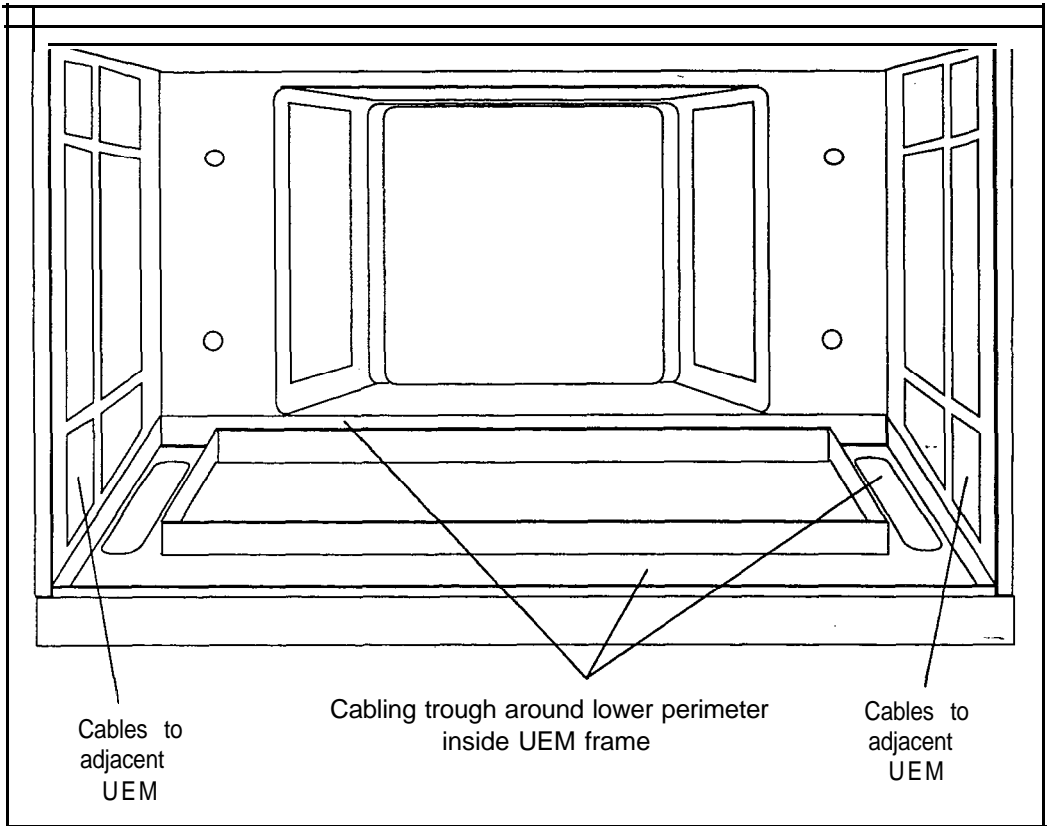

Cable installation

- 1 Connect the **QPC581** Changeover & Memory Arbitrator (CMA) circuit of CPU module 0 to the CMA circuit of CPU module 1 with one **NT8D85** cable and one **NT8D80** cable.
 - Figure 20-3 illustrates an CPU module **front** panel showing the locations of the CMA connectors.
 - Figure 20-4 illustrates the recommended cable routing path.

- 2 Connect the **QPC775** or **QPC471** Clock Controller (CC) circuit packs of CPU modules 0 and 1 to the **InterGroup** module with two **NT8D74** cables.
 - Figure 20-3 illustrates a CPU module front panel and an **InterGroup** Module, showing the locations of the CC connectors.
 - Figure 20-5 illustrates a **InterGroup** Module assembly.
 - Figure 20-4 illustrates the recommended cable routing path.

- 3 Connect the **QPC412** Inter Group Switch (IGS) circuits 0 and 1 of each network group to the **InterGroup** module using **NT8D76** cables.
 - Figure 20-6 illustrates an NET module front panel, showing the locations of the IGS connectors.
 - Figure 20-5 illustrates a **InterGroup** Module.
 - Table 20-1 provides a summary of IGS to **InterGroup** Module cabling information for quick reference.
 - Figures 20-7 through 20- 11 illustrate the recommended cable routing paths.



- 4 Connect the QPC215 Segmented Bus Extender (SBE) circuits of CPU modules 0 and 1 to the QPC441 3-Port Extender (3PE) circuits of Network modules 0 and 1 for every network group, using **NT8D80** cables.
 - Figure 20-3 illustrates an CPU module front panel, showing the locations of the SBE connectors.
 - Figure 20-6 illustrates an NET module front panel, showing the locations of the 3PE connectors.
 - Table 20-2 provides a summary of SBE to 3PE cabling information for quick reference.
 - Figures 20-7 through 20-1 1 illustrate the recommended cable routing paths.

- 5 Seat and secure all connectors.

Figure 20-3
CMA, SBE, and CC to CPU module cabling diagram

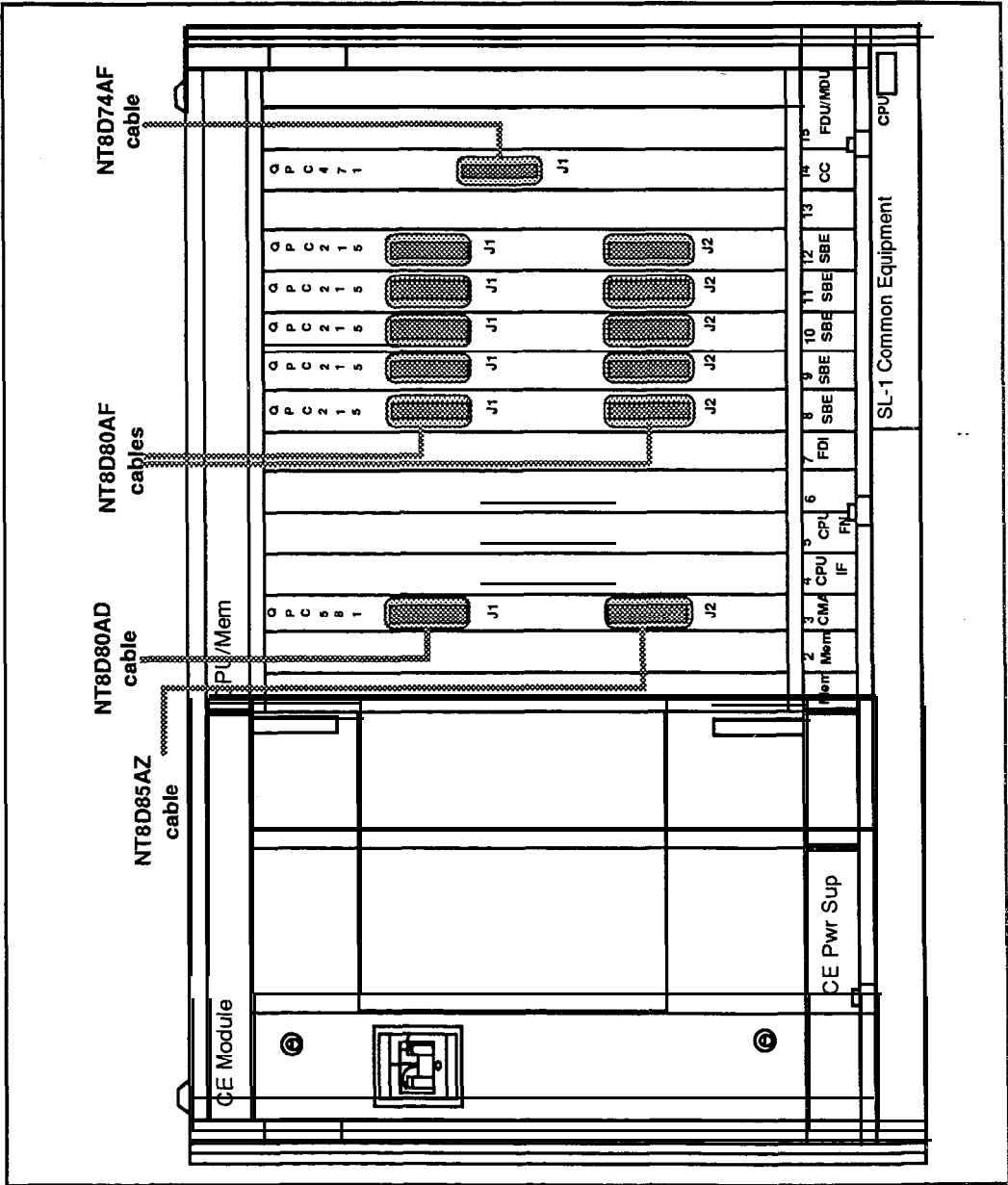

Figure 20-4
Cable routing diagram — CPU CC to InterGroup Module / CPU 1 CMA to CPU 0 CMA

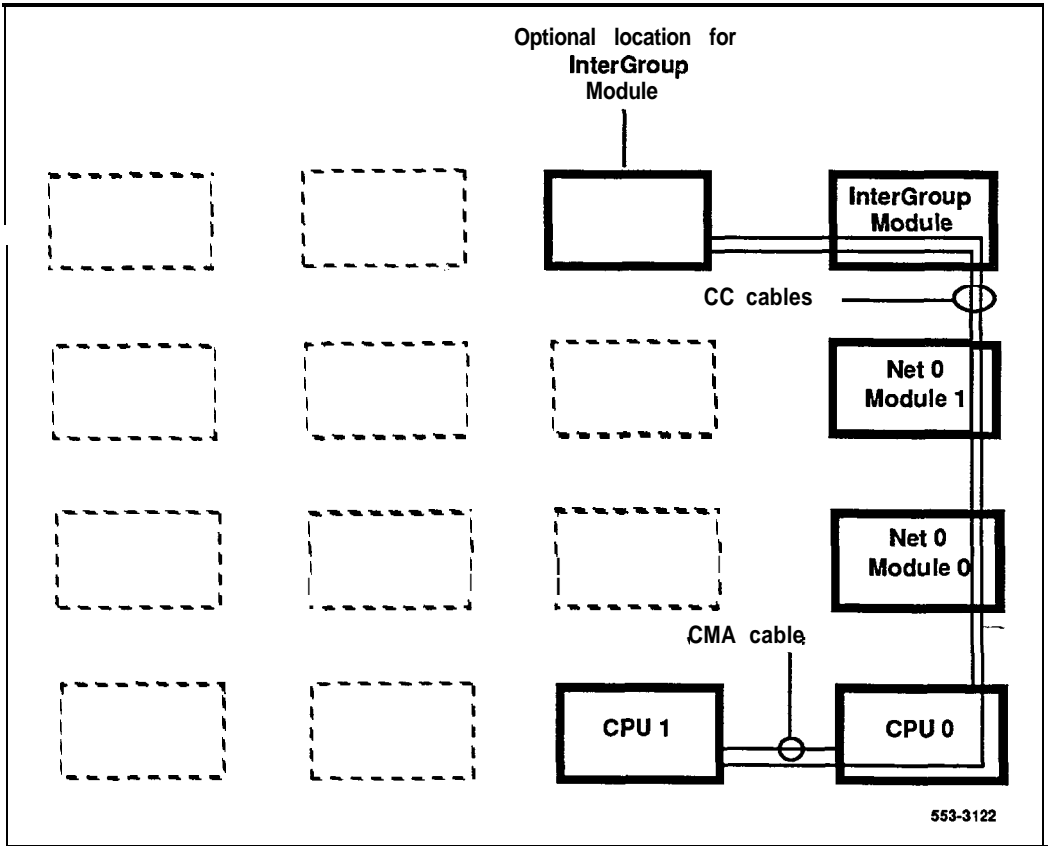

Figure 20-5
InterGroup Switch (IGS) and Clock Controller (CC) to InterGroup module cabling diagram

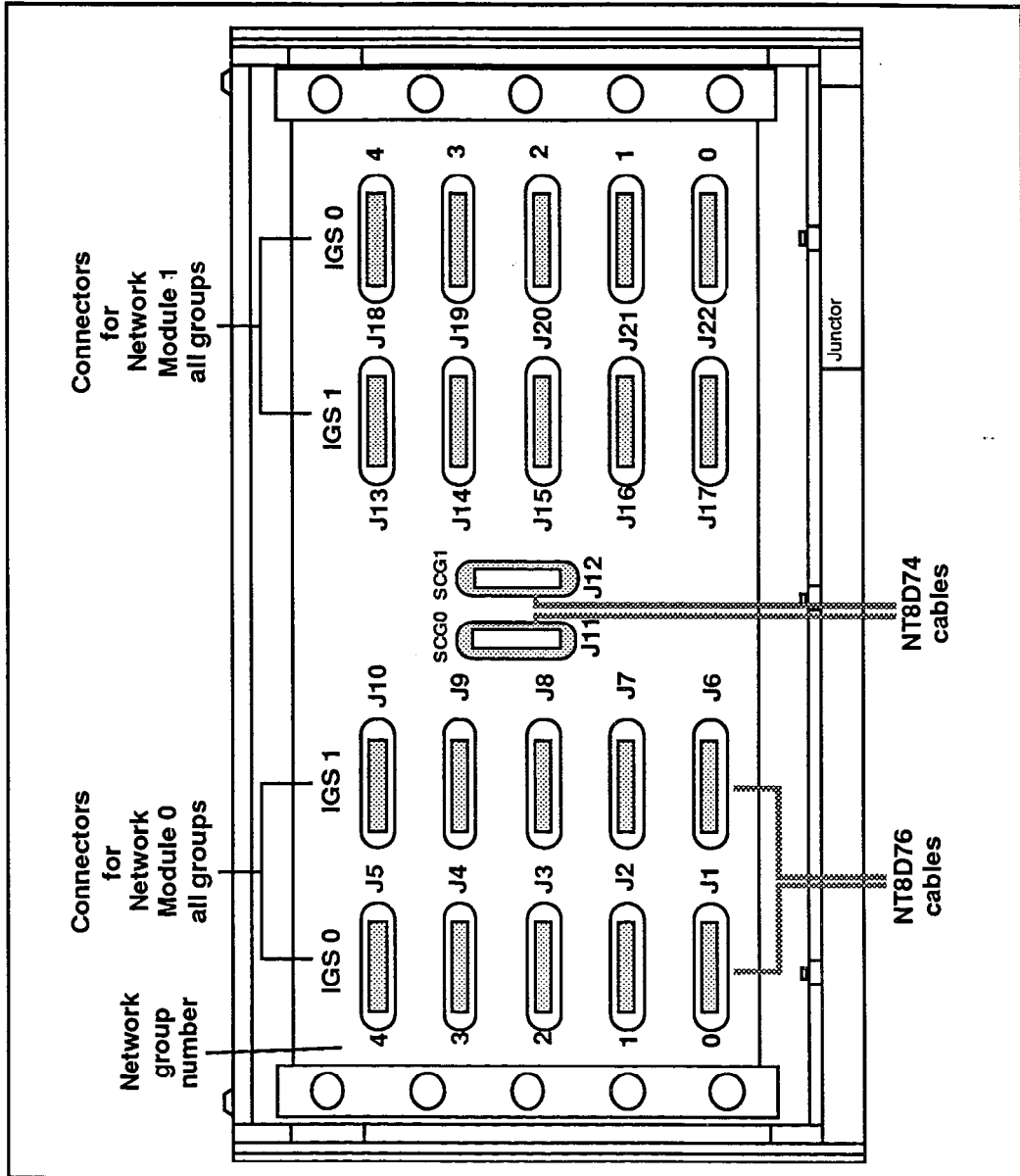

Figure 20-6
3PE and IGS to Network module cabling diagram

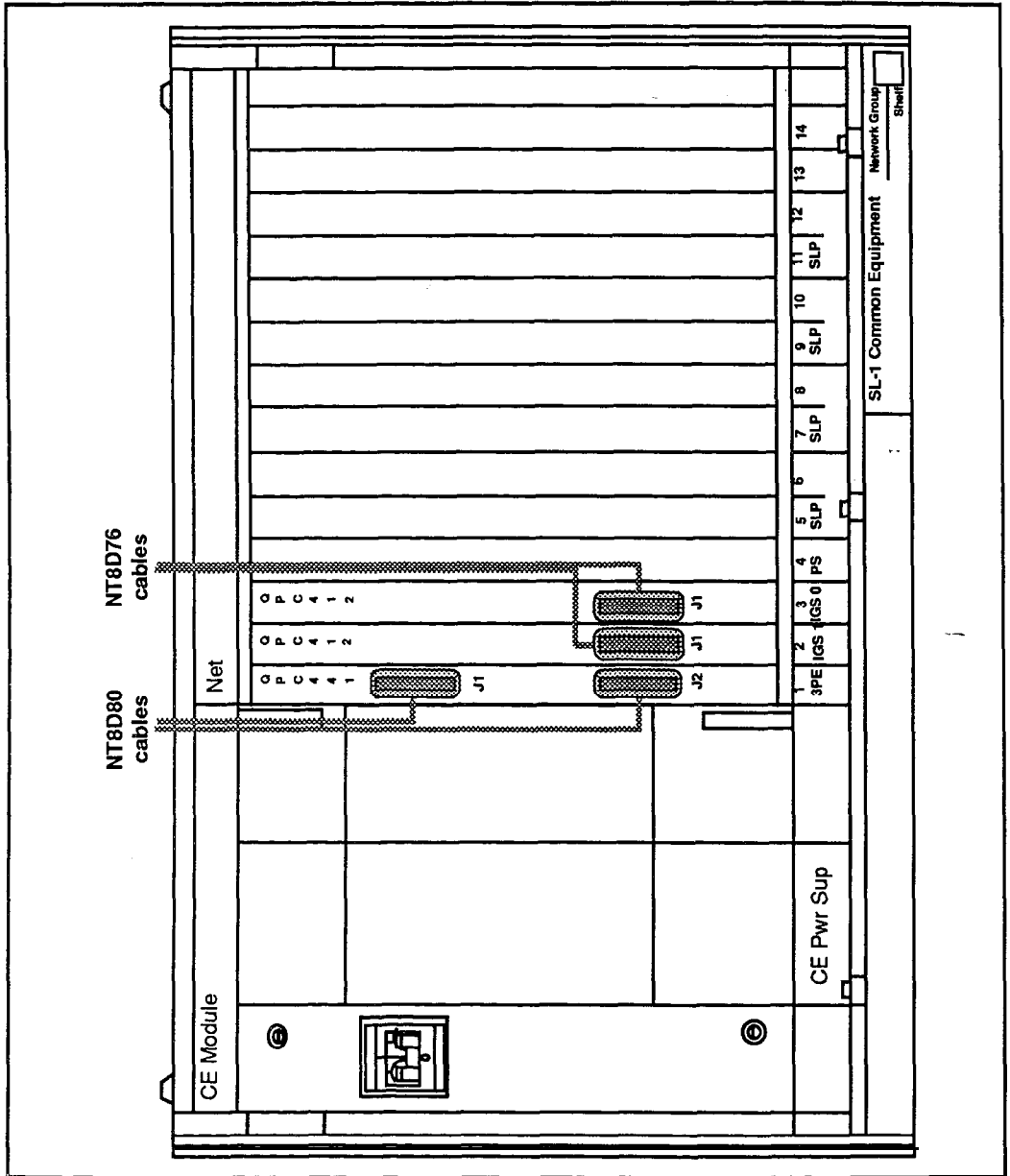

Table 20-1
Network Module IGS to InterGroup Module cable assignment

NT8D76 cables			To
From			
Network Group	Network Module	IGS Circuit	InterGroup Module Connector
0	0	0	J1
0	0	1	J6
0	1	1	J17
0	1	0	J22
1	0	0	J2
1	0	1	J7
1	1	1	J16
1	1	0	J21
2	0	0	J3
2	0	1	J8
2	1	1	J15
2	1	0	J20
3	0	0	J4
3	0	1	J9
3	1	1	J14
3	1	0	J19
4	0	0	J5
4	0	1	J10
4	1	1	J13
4	1	0	J18

Table 20-2
CPU Module SBE to Network Module 3PE cable assignment

NT8D80 cables					
From			To		
CPU Module	SBE Circuit	SBE Connector	Network Group	Network Module	3PE Connector
0	0	J3	0	0	J3
0	0	J4	0	0	J4
0	1	J3	1	0	J3
0	1	J4	1	0	J4
0	2	J3	2	0	J3
0	2	J4	2	0	J4
0	3	J3	3	0	J3
0	3	J4	3	0	J4
0	4	J3	4	0	J3
0	4	J4	4	0	J4
1	0	J3	0	1	J3
1	0	J4	0	1	J4
1	1	J3	1	1	J3
1	1	J4	1	1	J4
1	2	J3	2	1	J3
1	2	J4	2	1	J4
1	3	J3	3	1	J3
1	3	J4	3	1	J4
1	4	J3	4	1	J3
1	4	J4	4	1	J4

Figure 20-7
Cable routing diagram — Network Group 0 to InterGroup and CPU modules

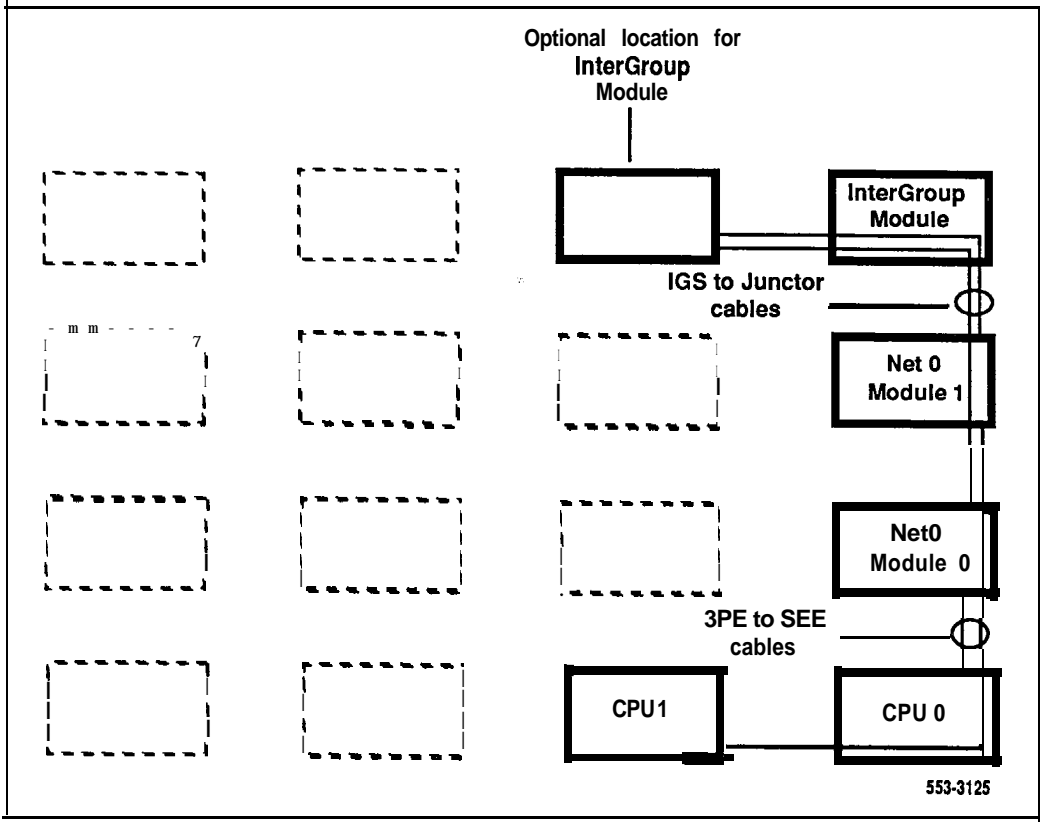

Figure 20-8
Cable routing diagram — Network Group 1 to InterGroup and CPU modules

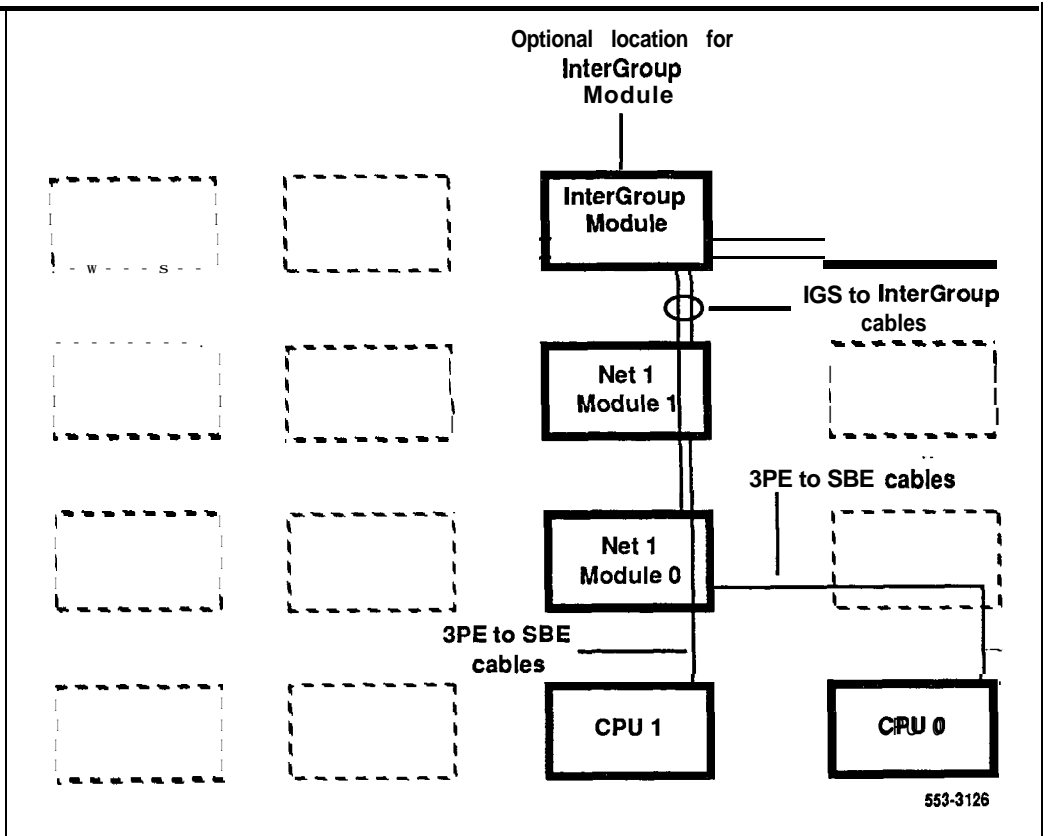

Figure 20-9
Cable routing diagram — Network Group 2 to InterGroup and CPU modules

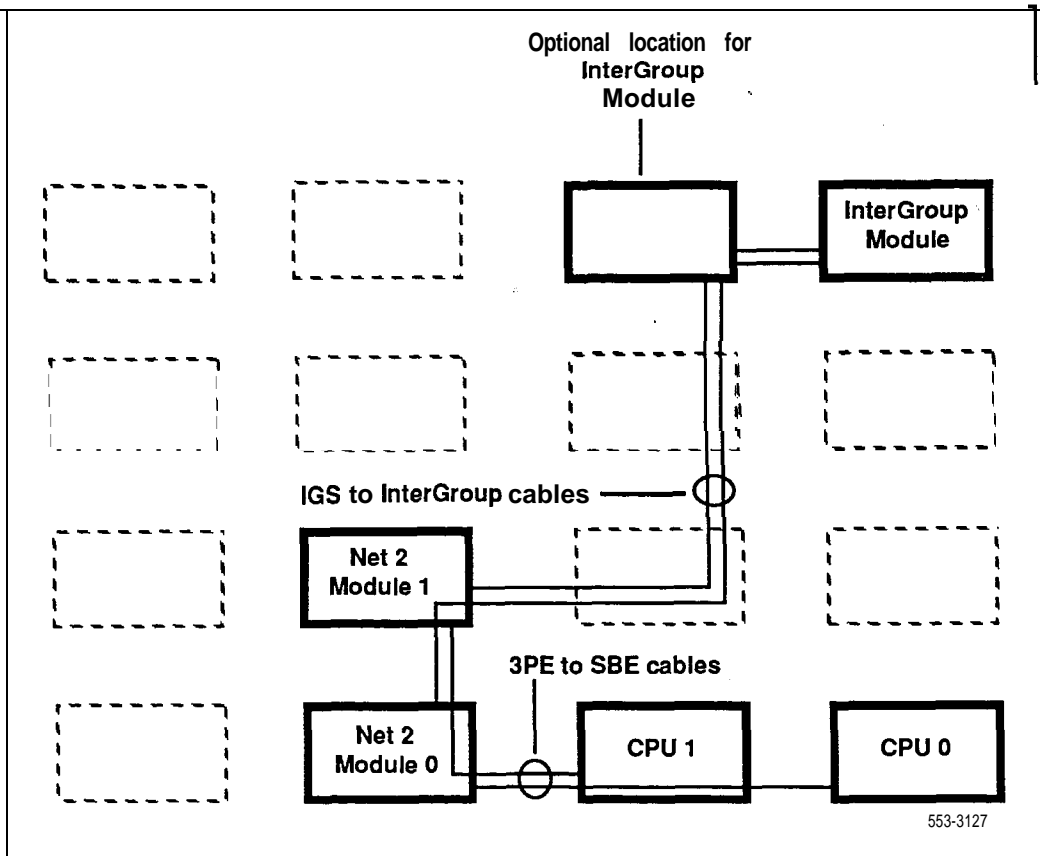

Figure 20-10
Cable routing diagram — Network Group 3 to InterGroup and CPU modules

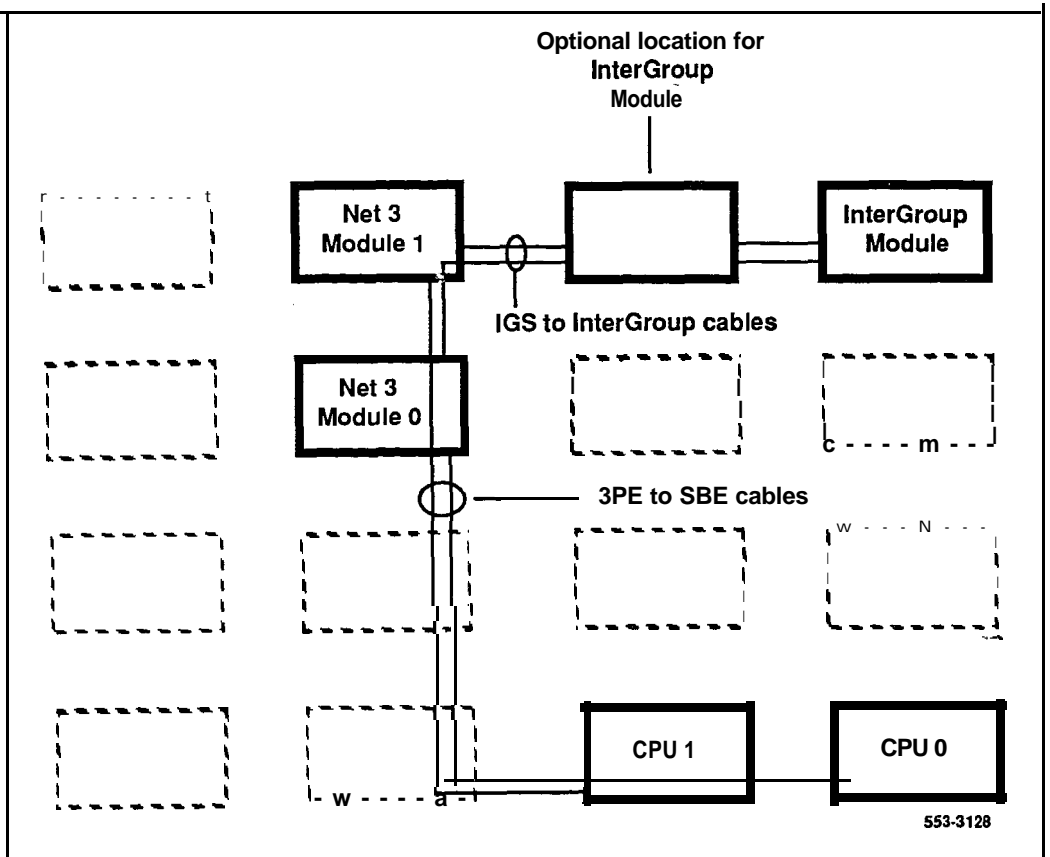
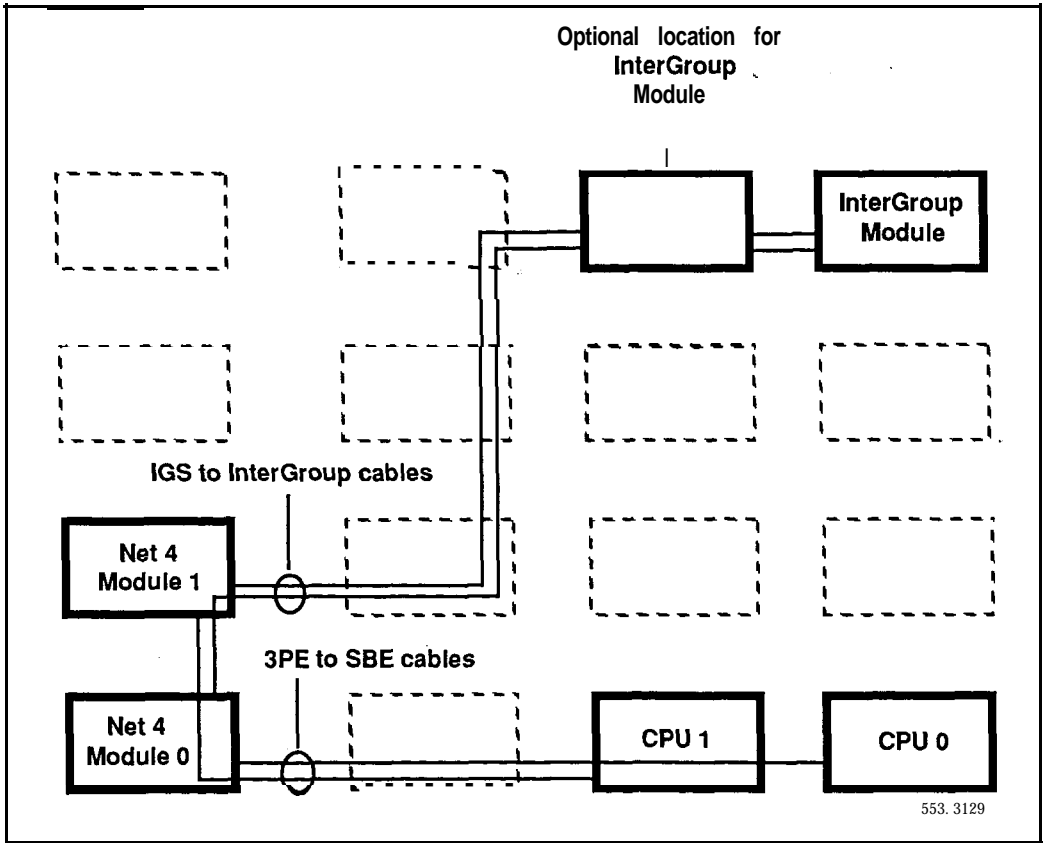

Figure 20-I 1
Cable routing diagram — Network Group 4 to InterGroup and CPU modules



Procedure 21: installing network loop cabling

General information

Use this procedure to install network loop cabling for an SL-1 system. Refer to System overview (553-3001-100) for detailed information about network loop configurations.

External cabling

When Peripheral Equipment UEMs are located in a separate row of equipment columns from the modules containing the network cards, external cables are required. In this case, shielded cables are used to connect the network cards to the peripheral controller cards.

Network circuit packs are connected to the I/O panel at the rear of the module containing the network cards using the following cables:

NT8D88AD cables for NT8D04AA Superloop Network cards

NT8D86AD cables for QPC414 Network cards

Peripheral controller circuit packs are connected to the I/O panel at the rear of NT8D37 and NT8D13 Peripheral Equipment UEMs using the following cables:

NT8D92AB cables for NT8D01 AC/AD Controller cards

NT8D86AD cables for QPC659 Peripheral Buffer cards

Shielded cables are run from the I/O panel of the module containing the network cards to the I/O panel of the PE UEM. These cables are provided in lengths of 6, 12, 20, and 30 feet.

From the Network UEM to an NT8D37 PE UEM, use NT8D98 cables.

From the Network UEM to an NT8D13 PE UEM, use NT8D73 cables.

Internal cable installation

- 1 Refer to the work order and determine the following:
 - The type of network loop(s) being installed (regular loop or superloop).
 - The loop number(s) assigned to it.
 - The location of the network circuit pack(s) which provide the loop(s)
 - The location of the PE module(s) assigned to the loop.
- 2 Set the **ENB/DIS** switch on the faceplate of each QPC414 or **NT8D04AA** Superloop Network Card to **DIS** and insert it into its assigned slot.
- 3 Perform this step when cabling a Superloop from an **NT8D04AA** network card.

Connect the Superloop connectors of the **NT8D01** Controller Card in each PE module to one or more **NT8D04AA** network cards using **NT8D91** cables. The Superloop connectors are labelled **SLO**, **SL1**, **SL2**, and **SL3**, and are located on the backplane of the **NT8D37** PE module.

- Label both ends of each cable with the loop number assigned to it, then connect one end of each **NT8D91** cable to connector **JO** or **J1** on the **NT8D04AA** Network card faceplate.
- Figure 21-1 illustrates a typical module front panel, showing the locations of the connectors on the **NT8D04AA** network card.
- Remove the I/O panel cover from the rear of the **NT8D37** PE UEM to gain access to the shelf backplane.
- Connect the other end of the cable to Superloop connector **SLO**, **SL1**, **SL2**, or **SL3** on the rear of the **NT8D37** PE module backplane.
- Figure 21-2 illustrates an **NT8D37** PE module backplane, showing the locations of the Superloop connectors.

- 4 Perform this step when cabling a network loop from a QPC414 Network card.

Connect the loop connectors of the QPC659 Dual Loop Buffer (**DLB**) card in each PE module to one or more QPC414 network cards using **NT8D85** cables.

- Label both ends of the cable with the loop number assigned to it, then connect one end of each **NT8D85** cable to connector **J1** (for the even numbered loop) or **J2** (for the odd numbered loop) on the assigned QPC414 Network card faceplate.
 - Figure 21-1 illustrates a typical module front panel, showing the locations of the connectors on the QPC414 Network card,
 - Connect the other end of the cable to the LPX or LPY connector assigned to the loop.
 - Figure 21-3 illustrates an **NT8D13** PE module front panel showing the locations of the loop connectors.
- 5 Set the **ENB/DIS** switch on the front of each QPC414 or **NT8D04AA** network card to **ENB**.
 - 6 Seat and secure all connectors. --
 - 7 If adding a loop or superloop to an operating system, enter the related loop assignment information as detailed in the ***SL-1 X11 input/output guide*** (553-3001-400).

Figure 21-1
QPC414 and NT8D04AA connections

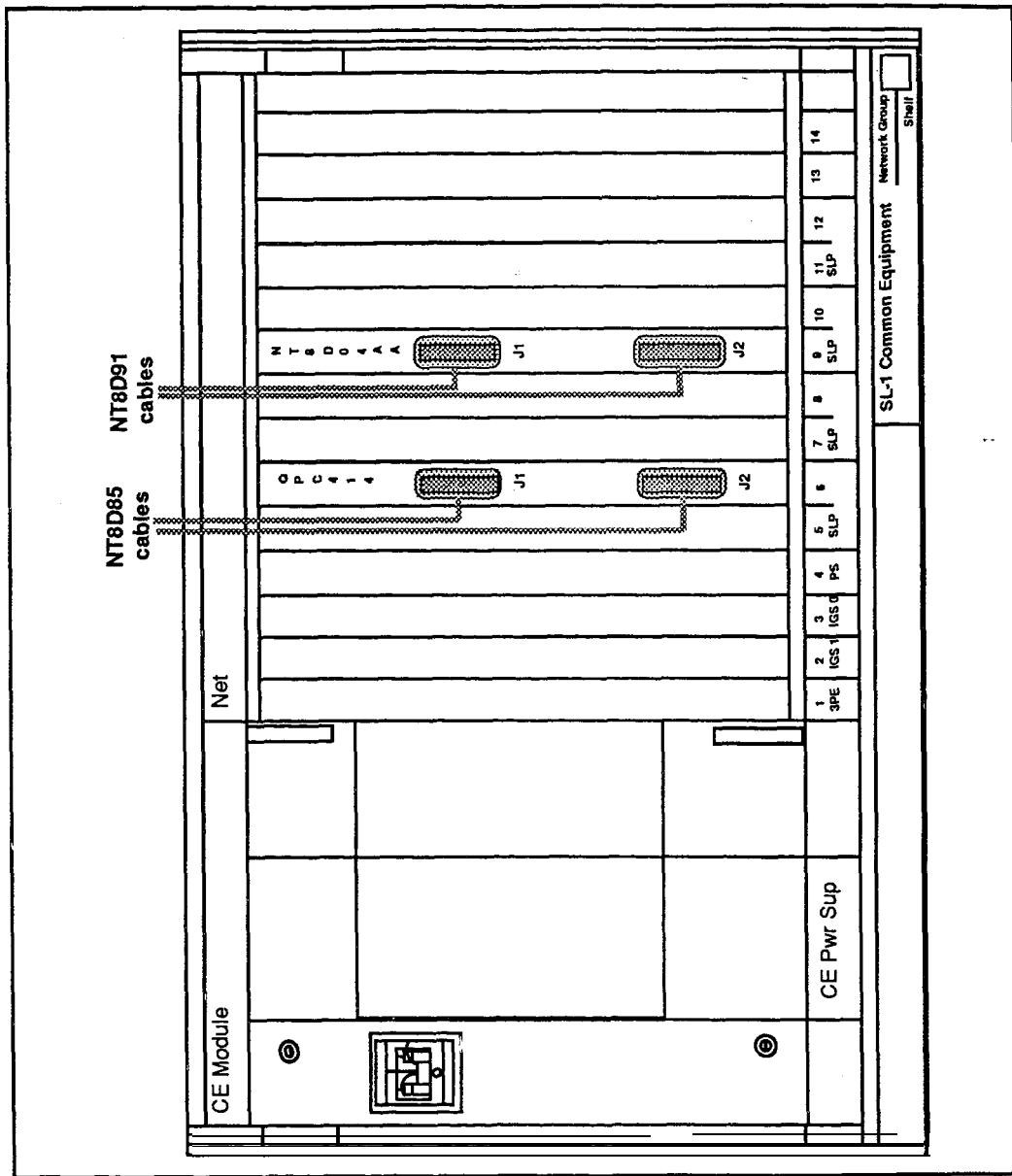

Figure 21-2
Superloop connectors SL0,SL1,SL2,SL3 on NT8D37 PE Module backplane

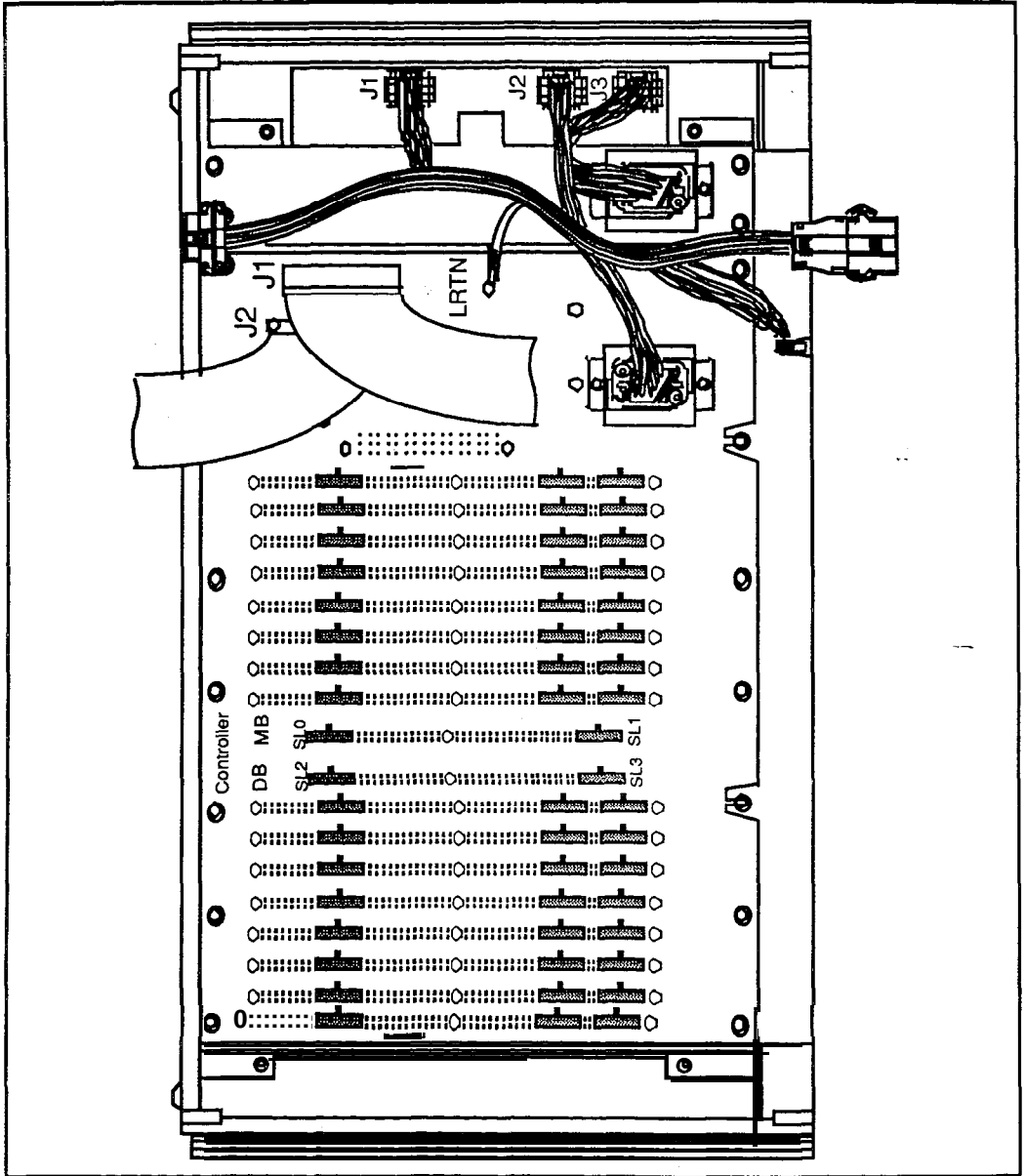
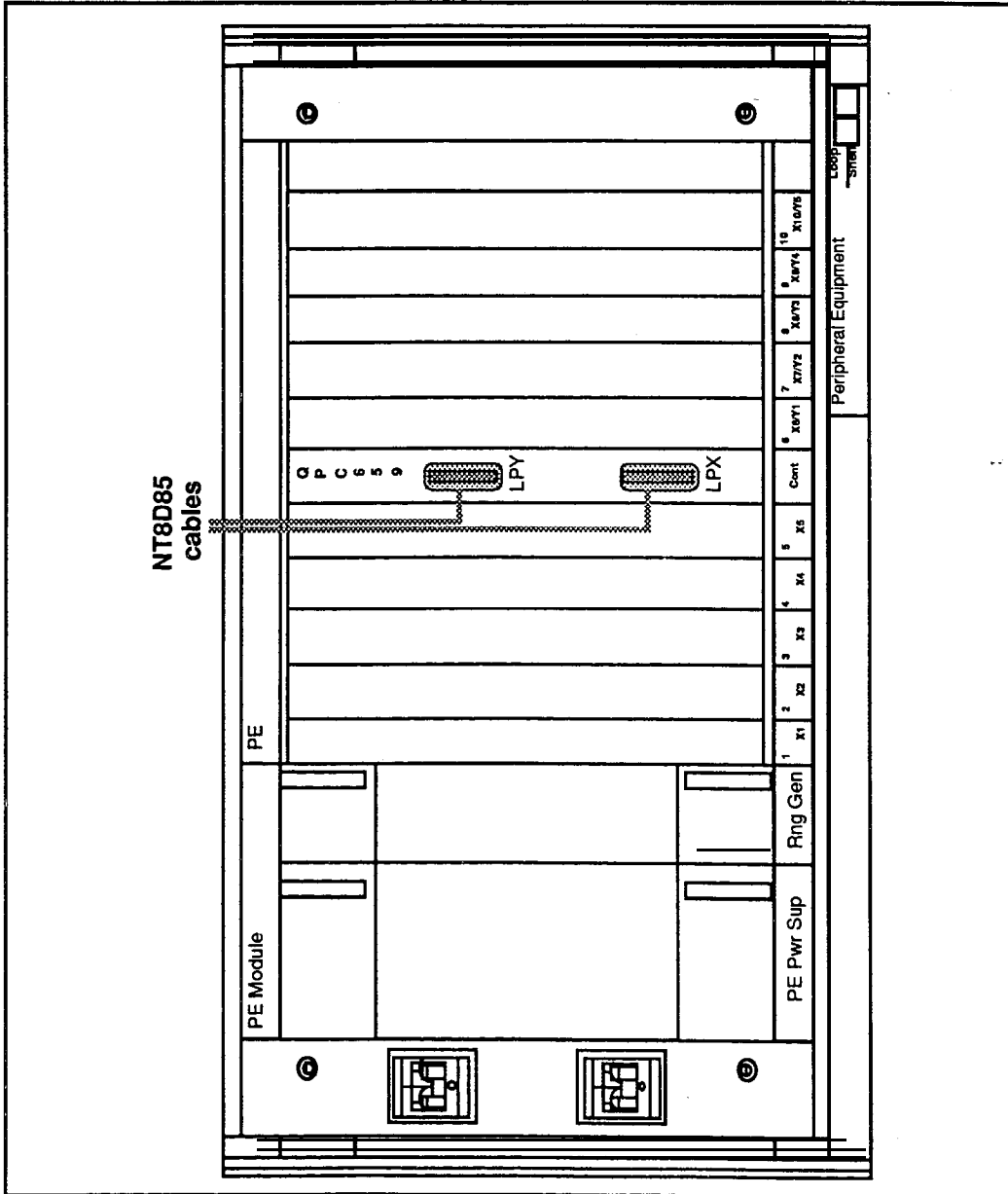

Figure 21-3
 QPC659 Dual Loop Buffer (DLB) connections on NT8D13 PE Module



External cable installation

- 1 Refer to the work order and determine the following:
 - The type of network loop(s) being installed (regular loop or superloop).
 - The loop number(s) assigned to it.
 - The location of the network circuit pack(s) which provide the **loop(s)**
 - The location of the PE module(s) assigned to the loop.
- 2 Set the **ENB/DIS** switch on the faceplate of each QPC414 or **NT8D04AA** Superloop Network Card to **DIS** and insert it into its assigned slot.
- 3 Perform this step when cabling a network loop from a QPC414 Network card.

Connect one end of an **NT8D86AD** cable to connector **J1** (for the even numbered loop) or **J2** (for the odd numbered loop) on the faceplate of the assigned QPC414 network card. See Figure 21-4.

Route the other end of the cable to the left side I/O panel at the rear of the UEM, and mount its connector in one of the cutouts in the I/O panel. See Figure 21-5.

- For ease of cable routing and cable identification, it is recommended that the I/O panel cutouts be allocated in the following sequence: **J20, J17, J16, J2, J1, J4**.

Connect one end of a second **NT8D86AD** cable from connector **LPX** or **LPY** on the assigned QPC659 peripheral buffer card. See Figure 21-6.

Mount the other end of the cable in the opening designated **J1 (LPX)** or **J2 (LPY)** in the I/O panel at the rear of the PE UEM. See Figure 21-7.

Route an **NT8D73** cable between the Network and PE I/O panels.

- 4 Perform this step when cabling a network superloop from an **NT8D04AA** Network card.

Connect one end of an **NT8D88AD** cable to connector JO or **J1** (refer to work order for superloop assignment) on the faceplate of the assigned **NT8D04AA** network card. See Figure 214.

Route the other end of the cable to the left side I/O panel at the rear of the UEM, and mount its connector in one of the cutouts in the I/O panel. See Figure 21-5.

- For ease of cable routing and cable identification, it is recommended that the I/O panel cutouts be allocated in the following sequence: 528,525, J9, J12.

Connect an **NT8D92AB** cable to the assigned superloop connector (SLO through SL3) on the PE UEM backplane. See Figures 21-2.

Mount the connector on the other end of the cable in its corresponding position in the I/O panel at the rear of the UEM. See Figure 21-8.

- For ease of cable identification, it is recommended that the superloops be cabled to the I/O panel cutouts as follows: SLO to J2, **SL1** to **J3**, SL2 to **J4**, SL3 to J.5

Route an **NT8D98** cable between the Network and PE I/O panels.

- 5 Set the **ENB/DIS** switch on the front of each QPC414 or **NT8D04AA** network card to **ENB**.
- 6 Seat and secure all connectors.
- 7 If adding a loop or superloop to an operating system, enter the related loop assignment information as detailed in the ***SL-I XII input/output guide***.

Figure 21-4
 NT8D04AA and QPC414 Network card to I/O panel cables

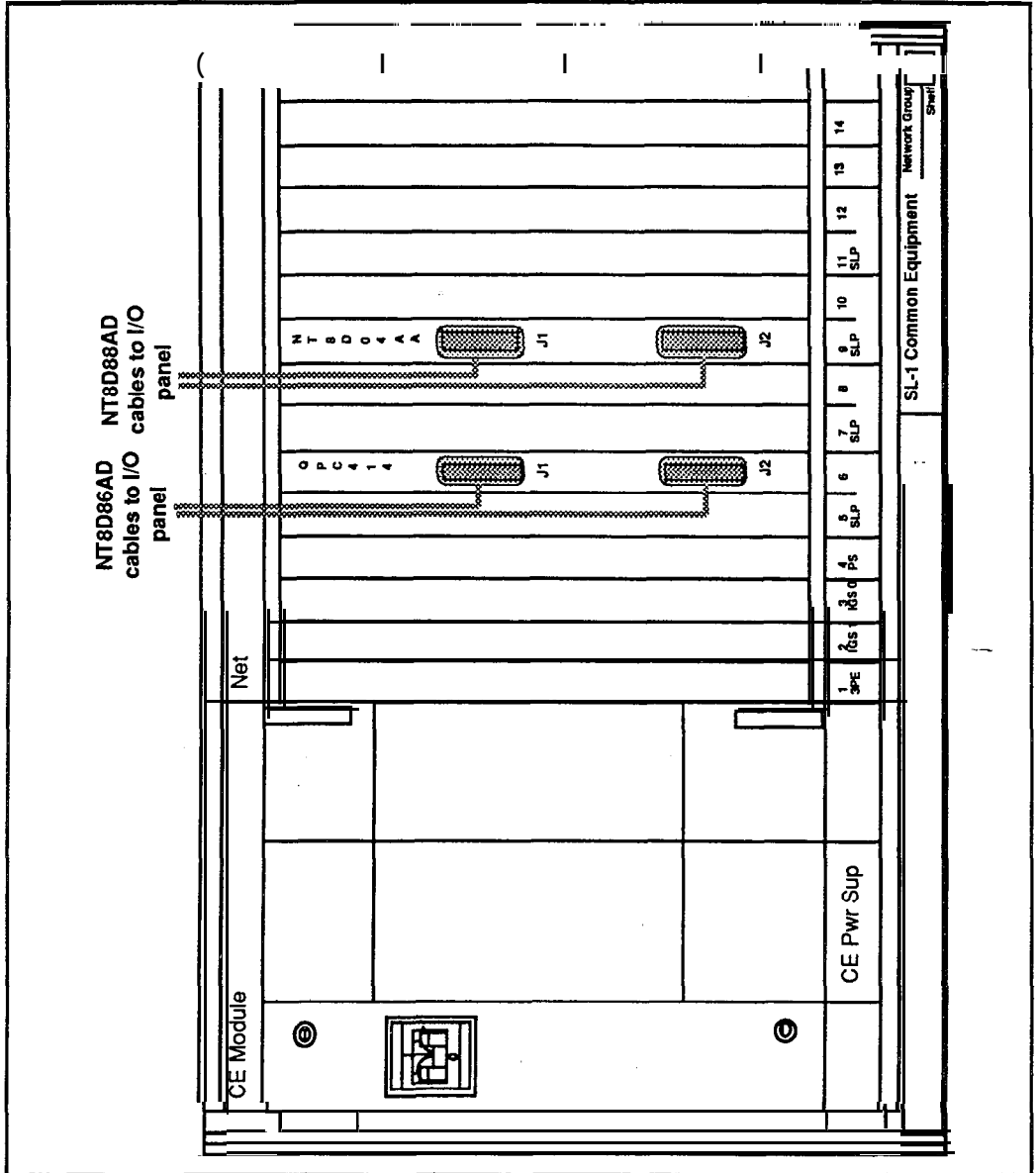

Figure 21-5
NT8D35 Network Module I/O connector panels

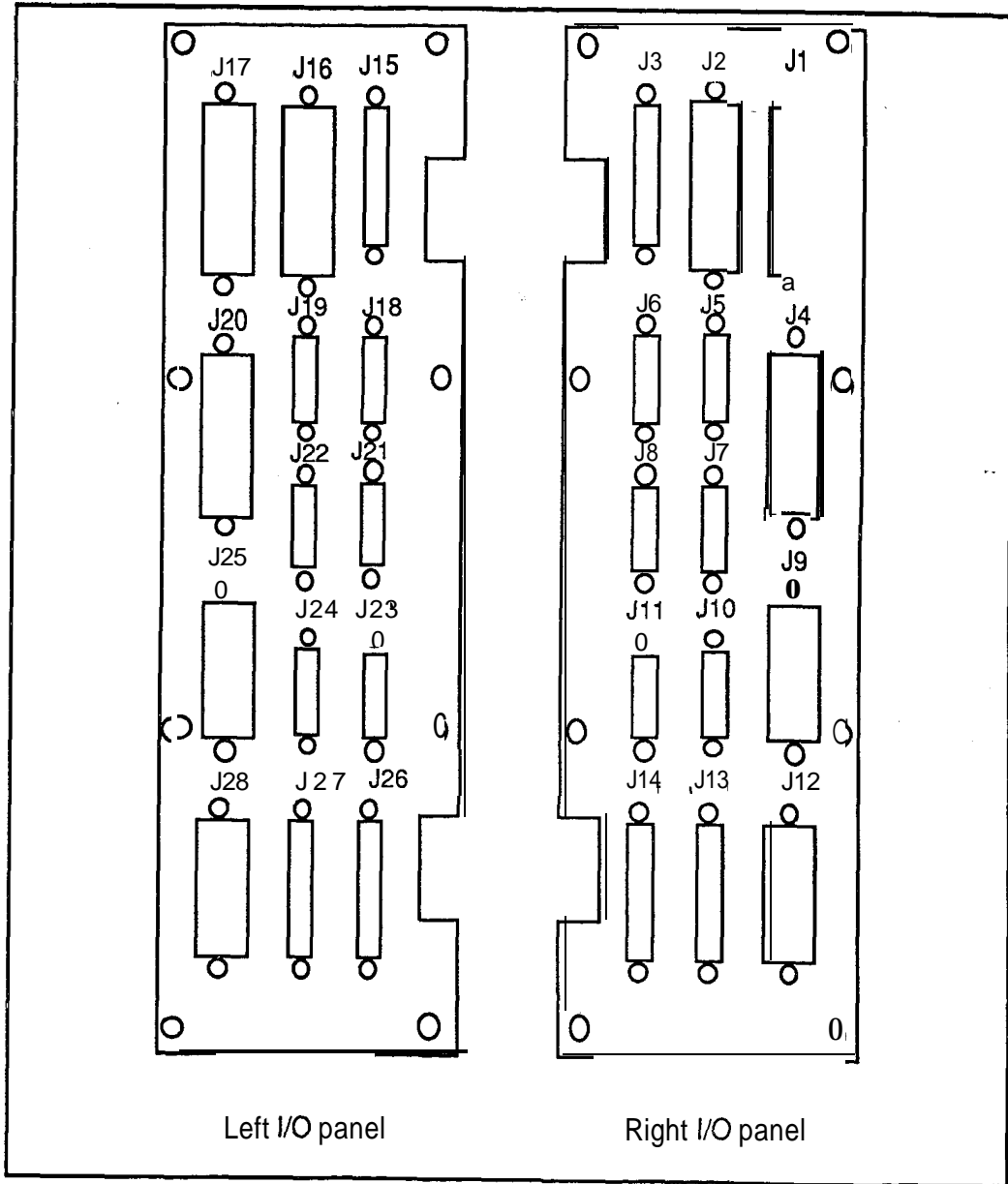

Figure 21-6
QPC659 Peripheral Buffer card to I/O panel cables

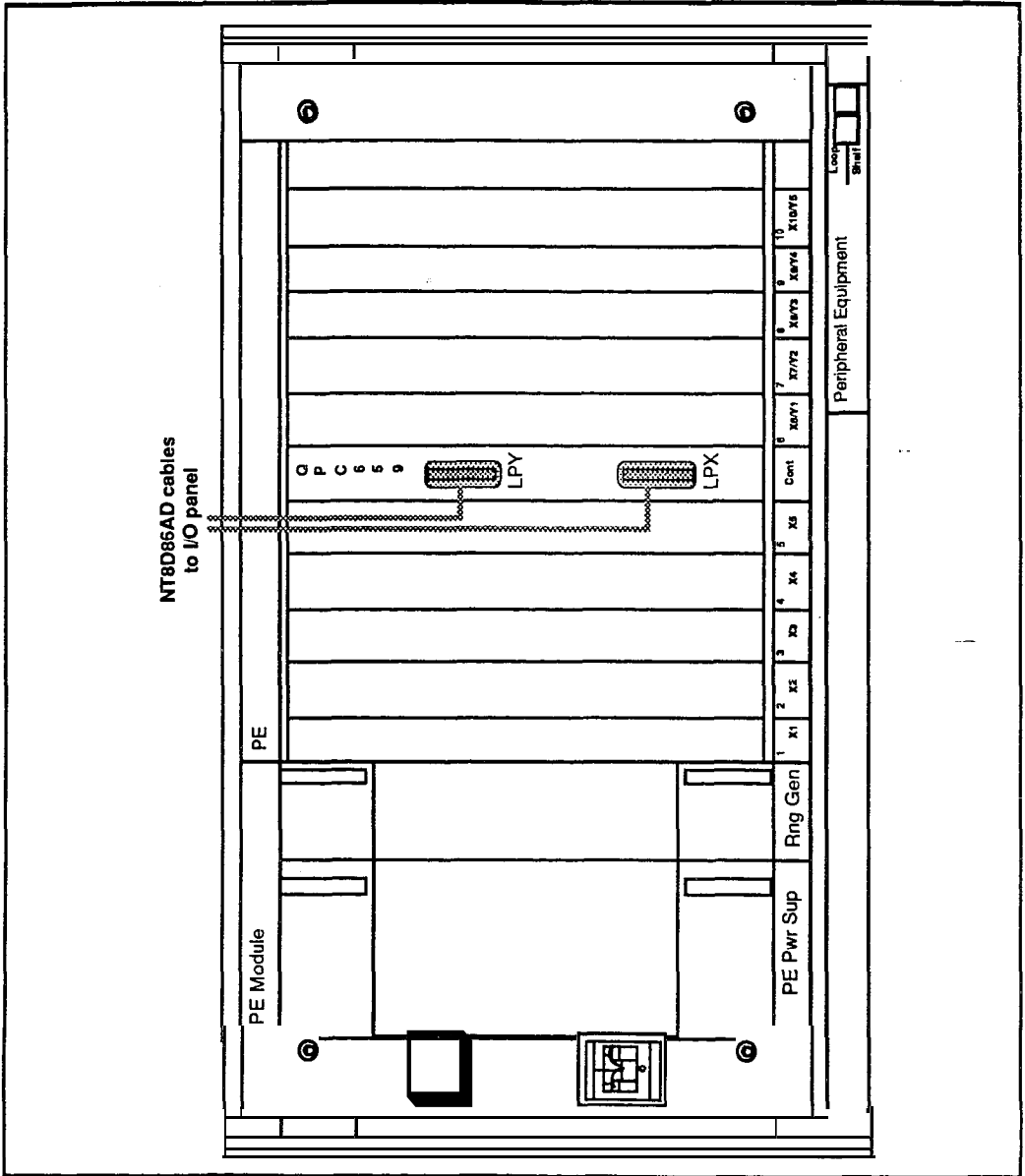

Figure 21-7
NT8D13 PE Module I/O panels

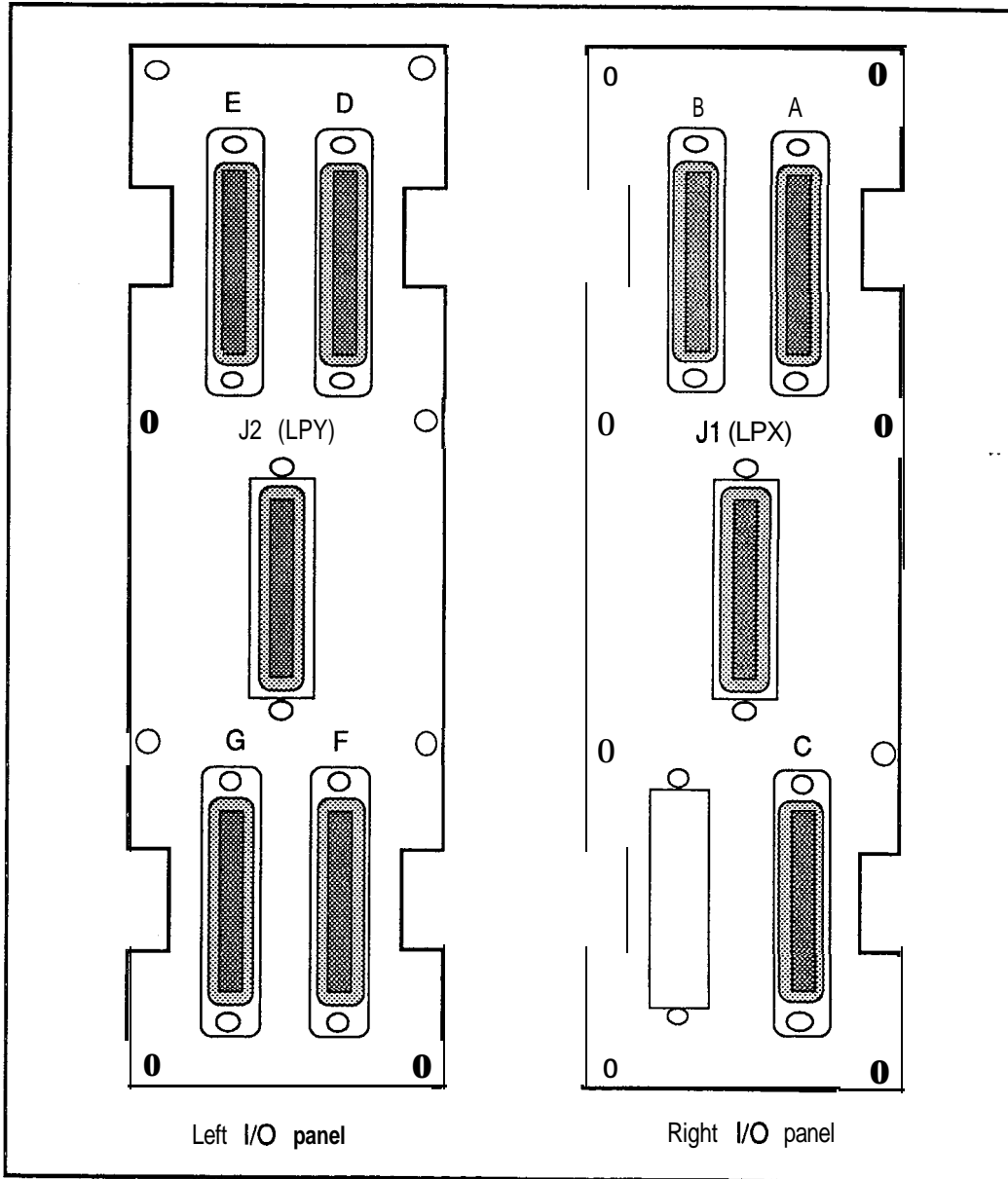
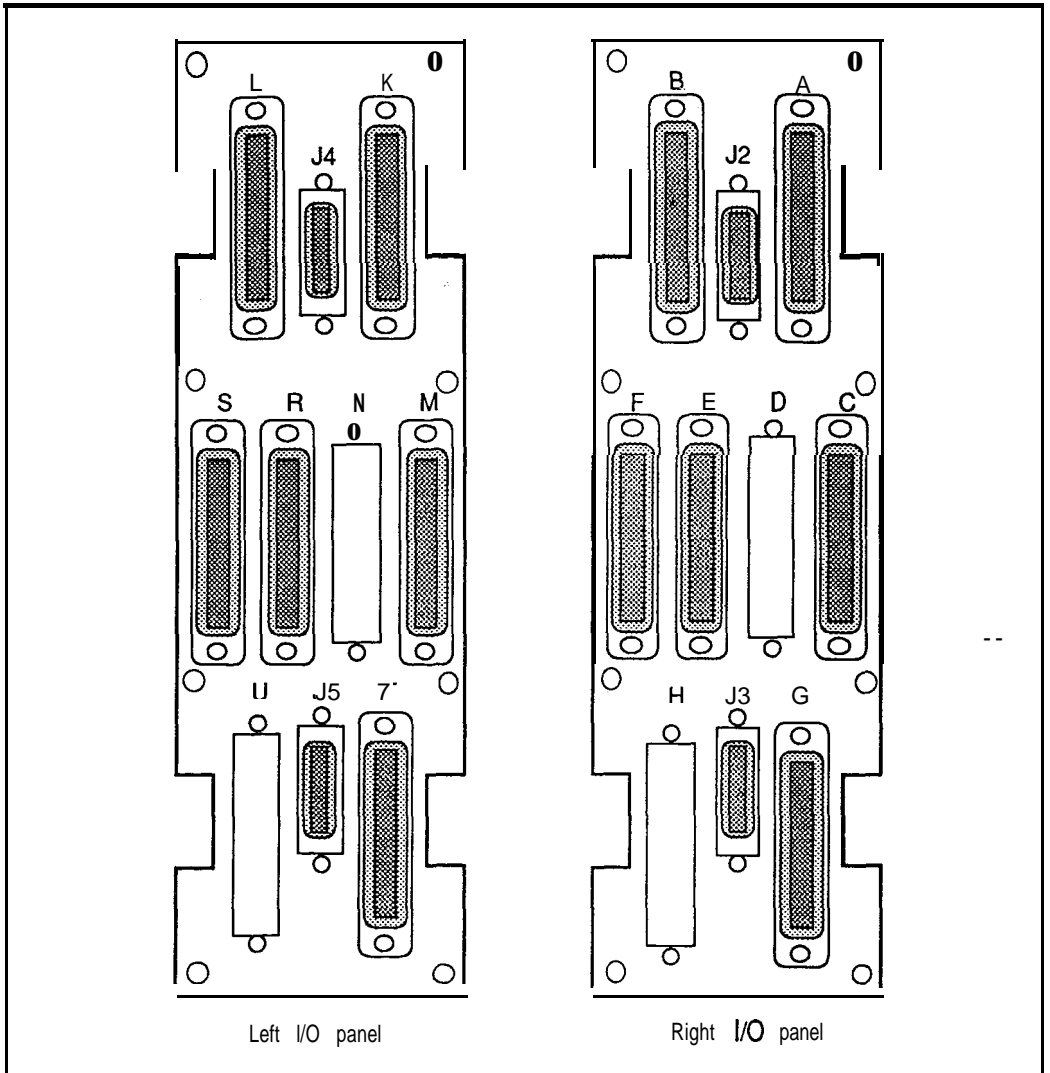

Figure 21-8
NT8D37 PE Module I/O panels





Procedure 22

Cabling NT8D11 CE/PE modules to the cross-connect terminal

General information

Use this procedure to install cables to the cross connect terminal from the NT8D11 Common/Peripheral Equipment Module. For cross-connect information about other PE modules, *see Procedure 23: Cabling NT8D37 and NT8D13 PE modules to the cross-connect terminal.*

The CE/PE module is equipped with a series of connectors mounted on the I/O panel at the rear of the module which extend the pins from the peripheral equipment card slots in the module. These I/O connectors are connected to the cross connect terminal with NE-A25B type or equivalent cables.

Cable installation

- 1 Select an appropriate number of NE-A25B type cables of sufficient length to reach from the I/O connector panel of the CE/PE module to the cross-connect terminal. --
 - Figure 22-1 illustrates the left and right I/O connector panels on the rear of the NT8D11 CE/PE module.
- 2 Designate both ends of each cable with a cable tag indicating PE module number and I/O connector designation.
- 3 Connect the cables to the appropriate connectors on the I/O panel and run the cables to the cross-connect terminal.
- 4 Terminate the cables from the PE module on the cross-connect block designated with the appropriate PE module number.

- Tables 22-2 through 22-4 illustrate the pair-termination assignments for **NT8D02AA**, **NT8D03AA**, and **NT8D09AA** line cards on the I/O connectors of the **CE/PE** module.
- Tables 22-5 through 22-19 illustrate the pair-termination assignments for the **NT8D14AA** Universal Trunk Card and the **NT8D15AA** E&M Trunk Card on the I/O connectors of the **CE/PE** module.

Note: The terminal blocks for PE modules are located on all rows except the bottom row on the horizontal side of the main cross-connect terminal when frame mounted blocks are used, or in the white field when wall mounted blocks are used. See **Procedure 16: Designating the cross-connect terminal**, for more details.

- 5 All cables must be neatly run, properly seated, and secured with cable ties.

Figure 22-1
NT8D11 CE/PE Module I/O panels

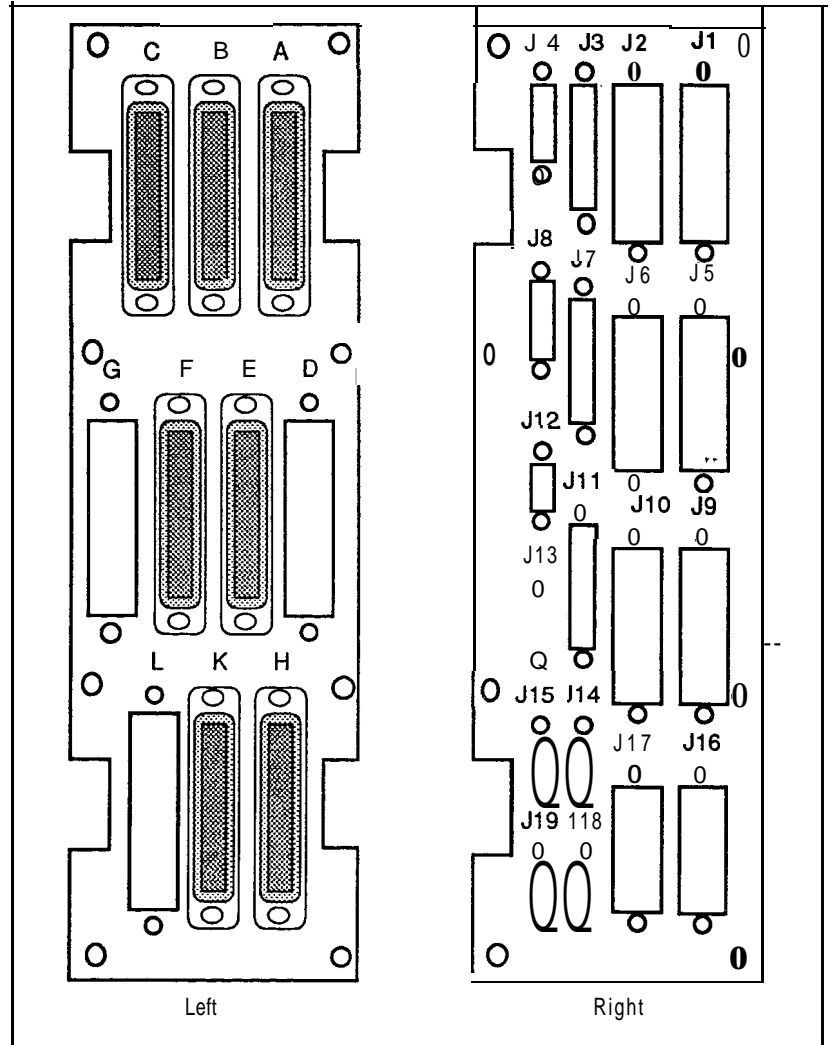

Table 22-2
Line card pair-terminations for I/O panel connector A

Pair	Pins	Pair Color	I/O Panel Connector	Unit Number
			A	16 Units Per Card
1T 1R	26 1	W-BL BL-W	S L O T 0	Unit 0
2T 2R	27 2	W-O O-W		Unit 1
3T 3R	28 3	W-G G-W		Unit 2
4T 4R	29 4	W-BR BR-W		Unit 3
5T 5R	30 5	W-S S-W		Unit 4
6T 6R	31 6	R-BL BL-R		Unit 5
7T 7R	32 7	R-O O-R		Unit 6
8T 8R	33 8	R-G G-R		Unit 7
9T 9R	34 9	R-BR BR-R		Unit 8
10T 10R	35 10	R-S S-R		Unit 9
11T 11R	36 11	BK-BL BL-BK		Unit 10
12T 12R	37 12	BL-O O-BK		Unit 11
13T 13R	38 13	BK-G G-BK		Unit 12
14T 14R	39 14	BK-BR BR-BK		Unit 13
15T 15R	40 15	BK-S S-BK		Unit 14
16T 16R	41 16	Y-BL BL-Y		Unit 15

Table 22-3
Line card pair-terminations for I/O panel connectors B,E,H

Pair	Pins	Pair Color	I/O Panel Connector			Unit Number
			B	E	H	16 Units Per Card
1T 1R	26 1	W-BL BL-W	S L O T 1	S L O T 4	S L O T 7	Unit 0
2T 2R	27 2	W-O O-W				Unit 1
3T 3R	28 3	W-G G-W				Unit 2
4T 4R	29 4	W-BR BR-W				Unit 3
5T 5R	30 5	W-S S-W				Unit 4
6T 6R	31 6	R-BL BL-R				Unit 5
7T 7R	32 7	R-O O-R				Unit 6
8T 8R	33 8	R-G G-R				Unit 7
9T 9R	34 9	R-BR BR-R				Unit 8
10T 10R	35 10	R-S S-R				Unit 9
11T 11R	36 11	BK-BL BL-BK				Unit 10
12T 12R	37 12	BL-O O-BK				Unit 11
13T 13R	38 13	BK-G G-BK				Unit 12
14T 14R	39 14	BK-BR BR-BK				Unit 13
15T 15R	40 15	BK-S S-BK				Unit 14
16T 16R	41 16	Y-BL BL-Y				Unit 15
17T 17R	42 17	Y-O O-Y	S L O T 2	S L O T 5	S L O T a	Unit 0
18T 18R	43 18	Y-G G-Y				Unit 1
19T 19R	44 19	Y-BR BR-Y				Unit 2
20T 20R	45 20	Y-S S-Y				Unit 3
21T 21R	46 21	V-BL BL-V				Unit 4
22T 22R	47 22	V-O O-V				Unit 5
23T 23R	48 23	V-G G-V				Unit 6
24T 24R	49 24	V-BR BR-V				Unit 7
25R 25T	50 25	V-S S-V				Spare

Table 22-4
Line card pair-terminations for I/O panel connectors C,F,K

Pair	Pins	Pair Color	I/O Panel Connector			Unit Number
			C	F	K	16 Units Per Card
1T 1R	26 1	W-BL BL-W	S L O T 2	S L O T 5	S L O T 6	Unit 8
2T 2R	27 2	w - o o - w				Unit 9
3T 3R	28 3	W-G G-W				Unit 10
4T 4R	29 4	W-BR BR-W				Unit 11
5T 5R	30 5	W-S S-W				Unit 12
6T 6R	31 6	R-BL BL-R				Unit 13
7T 7R	32 7	R-O O-R				Unit 14
8T 6R	33 8	R-G G-R				Unit 15
9T 9R	34 9	R-BR BR-R				Unit 0
10T 10R	35 10	R-S S-R				Unit 1
11T 11R	36 11	BK-BL BL-BK				Unit 2
12T 12R	37 12	BL-O O-BK				Unit 3
13T 13R	38 13	BK-G G-BK				Unit 4
14T 14R	39 14	BK-BR BR-BK				Unit 5
15T 15R	40 15	BK-S S-BK				Unit 6
16T 16R	41 16	Y-BL BL-Y	Unit 7			
17T 17R	42 17	Y-O O-Y	Unit 8			
18T 18R	43 16	Y-G G-Y	Unit 9			
19T 19R	44 19	Y-BR BR-Y	Unit 10			
20T 20R	45 20	Y-S S-Y	Unit 11			
21T 21R	46 21	V-BL BL-V	Unit 12			
22T 22R	47 22	V-O O-V	Unit 13			
23T 23R	48 23	V-G G-V	Unit 14			
24T 24R	49 24	V-BR BR-V	Unit 15			
25R 25T	50 25	V-S S-V	Spare			

Table 22-5
NT8D14AA Universal Trunk Card pair terminations
for I/O panel connector A

Lead design at ions			Pins	Pair Color	I/O Panel Connector	Unit Number
RAN mode	Paging mode	All other modes			A	
T0 R0	T0 R0	T0 R0	26 1	W-BL BL-W	S L O T 0	Unit 0
CP MB	A PG		27 2	W - O O - W		Unit 1
T1 R1	T1 R1	T1 R1	28 3	W-G G-W		Unit 2
CP MB	A PG		29 4	W-BR BR-W		Unit 3
T2 R2	T2 R2	T2 R2	30 5	W-S s-w		Unit 4
CP MB	A PG		31 6	R-BL BL-R		Unit 5
T3 R3	T3 R3	T3 R3	32 7	R-O O-R		Unit 6
CP MB	A PG		33 8	R-G G-R		Unit 7
T4 R4	T4 R4	T4 R4	34 9	R-BR BR-R		Unit 8
CP MB	A PG		35 10	R - S S-R		Unit 9
T5 R5	T5 R5	T5 R5	36 11	IBK-BL - BL-BK		Unit 10
CP MB	A PG		37 12	BK-S S-BK		Unit 11
T6 R6	T6 R6	T6 R6	38 13	BK-G G-BK		Unit 12
CP MB	A PG		39 14	BK-BR BR-BK		Unit 13
T7 R7	T7 R7	T7 R7	40 15	BK-S S-BK		Unit 14
CP MB	A PG		41 16	Y-BL BL-Y		Unit 15

Note: Use OVL 14 to select trunk termination impedance (60 Ω or 900Ω). See X11 input/output Guide (553-3001-400) for information about OVL 14.

Table 22-6
NT8D14AA Universal Trunk Card pair terminations
 for I/O panel connectors B,E,H

Lead designations			Pins	Pair Color	I/O Panel Connector			Unit Number												
RAN mode	Paging mode	All other modes			B	E	H													
T0 R0	T0 R0	T0 R0	26 1	W-BL BL-W	S L 0 T 1	S L O T 4	S L O T 7	Unit 0												
CP MB	A PG		27 2	W-O O-W																
T1 R1	T1 R1	T1 R1	28 3	W-G G-W				S L O T 1	S L O T 4	S L O T 7	Unit 1									
CP MR	A PG		29 4	W-BR BR-W																
T2 R2	T2 R2	T2 R2	30 5	W-S S-W							S L O T 1	S L O T 4	S L O T 7	Unit 2						
CP MB	A PG		31 6	R-BL BL-R																
T3 R3	T3 R3	T3 R3	32 7	R-O O-R										S L O T 1	S L O T 4	S L O T 7	Unit 3			
CP MB	A PG		33 8	R-G G-R																
T4 R4	T4 R4	T4 R4	34 9	R-BR BR-R													S L O T 1	S L O T 4	S L O T 7	Unit 4
CP MB	A PG		35 10	R-S S-R																
T5 R5	T5 R5	T5 R5	36 11	BK-BL BL-BK	S L O T 1	S L O T 4	S L O T 7													Unit 5
CP MB	A PG		37 12	BK-S S-BK																
T6 R6	T6 R6	T6 R6	38 13	BK-G G-SK				S L O T 1	S L O T 4	S L O T 7										Unit 6
CP MB	A PG		39 14	BK-BR BR-BK																
T7 R7	T7 R7	T7 R7	40 15	BK-S S-BK							S L O T 1	S L O T 4	S L O T 7							Unit 7
CP MB	A PG		41 16	Y-BL BL-Y																
T0 R0	T0 R0	T0 R0	42 17	Y-O O-Y										S L O T 2	S L O T 5	S L O T a				Unit 0
CP MB	A PG		43 18	Y - G G-Y																
T1 R1	T1 R1	T1 R1	44 19	Y-BR BR-Y													S L O T 2	S L O T 5	S L O T a	Unit 1
CP MB	A PG		45 20	Y-S S-Y																
T2 R2	T2 R2	T2 R2	46 21	V-BL BL-V	S L O T 2	S L O T 5	S L O T a													Unit 2
CP MB	A PG		47 22	V-O O-V																
T3 R3	T3 R3	T3 R3	48 23	V - G G-V				S L O T 2	S L O T 5	S L O T a										Unit 3
CP MB	A PG		49 24	V-BR BR-V																

Note: Use OVL 14 to select trunk termination impedance (600Ω or 900Ω). See XII *Input/output Guide* (553-3001-400) for information about OVL 14.

Table 22-7
NT8D14AA Universal Trunk Card pair terminations
 for I/O panel connectors C,F,K

Lead designation			Pins	Pair Color	I/O Panel Connector			Unit Number
RAN mode	Paging mode	All other modes			C	F	K	
T0 R0	T0 R0	T0 R0	26 1	W-BL BL-W	S L O T	S L O T	S L O T	Unit 4
CP MB	A PG		27 2	W-O O-W				
T1 R1	T1 R1	T1 R1	28 3	W-G G-W				Unit 5
CP MB	A PG		29 4	W-BR BR-W				
T2 R2	T2 R2	T2 R2	30 5	w-s s-w				Unit 6
CP MB	A PG		31 6	R-BL BL-R				
T3 R3	T3 R3	T3 R3	32 7	R-O O-R				Unit 7
CP MB	A PG		33 8	R-G G-R				
T4 R4	T4 R4	T4 R4	34 9	R-BR BR-R				Unit 0
CP MB	A PG		35 10	R-S S-R				
T5 R5	T5 R5	T5 R5	36 11	BK-BL BL-BK				Unit 1
CP MB	A PG		37 12	BK-S S-BK				
T6 R6	T6 R6	T6 R6	38 13	BK-G G-BK				Unit 2
CP MB	A PG		39 14	BK-BR BR-BK				
T7 R7	T7 R7	T7 R7	40 15	RK-S S-BK				Unit 3
CP MB	A PG		41 16	Y-BL BL-Y				
T0 R0	T0 R0	T0 R0	42 17	Y-O O-Y				Unit 4
CP MB	A PG		43 18	Y-G G-Y				
T1 R1	T1 R1	T1 R1	44 19	Y-BR BR-Y				Unit 5
CP MB	A PG		45 20	V-S S-Y				
T2 R2	T2 R2	T2 R2	46 21	V-BL BL-V				Unit 6
CP MB	A PG		47 22	V-O O-V				
T3 R3	T3 R3	T3 R3	48 23	V-G G-V				Unit 7
CP MB	A PG		49 24	Y-BR BR-V				

Note: Use OVL 14 to select trunk termination impedance (600Ω or 900Ω). See X11 in *Output Guide* (553-3001-400) for information about OVL 14.

Table 22-8
NT8D15AA E&M Trunk Card 2W Paging mode pair
terminations for I/O panel connector A

Pair	Pins	Pair Color	I/O Panel Connector	Unit Number
			A	
T0 R0	26 1	W-BL BL-W	S L O T 0	Unit 0
A PG	29 4	W-BR BR-W		Unit 1
T1 R1	30 5	w-s s-w		Unit 2
A PG	33 8	R-G G-R		Unit 3
T2 R2	34 9	R-BR BR-R		
A PG	37 12	BL-O O-BL		
T3 R3	38 13	BK-G G-BK		
A PG	41 16	Y-BL BL-Y		

Table 22-9
NT8D15AA E&M Trunk Card 2W Paging mode pair
terminations for I/O panel connectors B,E,H

Pair	Pins	Pair Color	I/O Panel Connector			Unit Number
			B	E	H	
T0 R0	26 1	W-BL BL-W	S L O T 1	S L O T 4	S L O T 7	Unit 0
A PG	29 4	W-BR BR-W				
T1 R1	30 5	W-S s-w				
A PG	33 8	R-G G-R				
T2 R2	34 9	R-BR BR-R				
A PG	37 12	BL-O O-BL				
T3 R3	38 13	BK-G G-BK				
A PG	41 16	Y-BL BL-Y				
T0 R0	42 17	Y-O O-Y				S L O T 2
A PG	45 20	Y-S S-Y				
T1 R1	46 21	V-BL BL-V				
A PG	49 24	V-BR BR-V				

Table 22-10
NT8D15AA E&M Trunk Card 2W Paging mode pair
terminations for I/O panel connectors C,F,K

Pair	Pins	Pair Color	I/O Panel Connector			Unit Number
			C	F	K	
T2 R2	26 1	W-BL BL-W	S	S	S	Unit 2
A P G	29 4	W-BR BR-W	L O	L O	L O	
T3 R3	30 5	w-s s-w	T	T	T	Unit 3
A P G	33 8	R-G G-R	2	5	8	
T0 R0	34 9	R-BR BR-R	S	S	S	Unit 0
A P G	37 12	BL-0 0-BL				
T1 R1	38 13	BK-G G-BK	L	L	L	Unit 1
A P G	41 16	Y-BL BL-Y	O	O	O	
T2 R2	42 17	Y-O O-Y	T	T	T	Unit 2
A P G	45 20	Y-S S-Y	3	6	9	
T3 R3	46 21	V-BL BL-V	3	6	9	Unit 3
A P G	49 24	V-BR BR-V				

Table 22-11
NT8D15AA E&M Trunk Card 2W Type 1 mode pair
terminations for I/O panel connector A

Pair	Pins	Pair Color	I/O Panel Connector	Unit Number
			A	
T R 0	26 1	W-BL BL-W	S L O T 0	Unit 0
E M	28 3	W-G G-W		Unit 1
T1 R1	30 5	w-s s-w		Unit 2
E M	32 7	R-O O-R		Unit 3
T2 R2	34 9	R-BR BR-R		
E M	36 11	BK-BL BL-BK		
T3 R3	38 13	BK-G G-BK		
E M	40 15	BK-S S-BK		

Table 22-12
NT8D15AA E&M Trunk Card 2W Type 1 mode pair
terminations for I/O panel connectors B,E,H

Pair	Pins	Pair Color	I/O Panel Connector			Unit Number
			B	E	H	
T0 R0	26 1	W-BL BL-W				Unit 0
E M	28 3	W-G G-W				
T1 R1	30 5	w-s s-w	S	S	S	Unit 1
E M	32 7	R-O O-R	L O	L O	L O	
T2 R2	34 9	R-BR BR-R	T	T	T	Unit 2
E M	36 11	BK-BL BL-BK	1	4	7	
T3 R3	38 13	BK-G G-BK				Unit 3
E M	40 15	BK-S S-BK				
T0 R0	42 17	Y-O O-Y	S	S	S	Unit 0
E M	44 19	Y-BR BR-Y	L O	L O	L O	
T1 R1	46 21	V-BL BL-V	T	T	T	Unit 1
E M	48 23	V-G G-V	2	5	8	

Table 2213
NT8D15AA E&M Trunk Card 2W Type 1 mode pair
terminations for I/O panel connectors C,F,K

Pair	Pins	Pair Color	I/O Panel Connector			Unit Number
			C	F	K	
I-2 R2	26 1	W-EL BL-w	S	S	S	Unit 2
E M	28 3	W-G G-W	L O	L O	L O	
T3 R3	30 5	w-s s-w	T	T	T	Unit 3
E M	32 7	R-O O-R	2	5	8	
T O - R O	3 9	4 R-BR BR-R	S	S	S	Unit 0
E M	36 11	BK-BL BL-BK				
T1 R1	38 13	BK-G G-BK	L	L	L	Unit 1
E M	40 15	BK-S S-BK	O	O	O	
T2 R2	42 17	Y-O O-Y	T	T	T	Unit 2
E M	44 19	Y-BR BR-Y	3	6	9	
T3 R3	46 21	V-BL BL-V	S	S	S	Unit 3
E M	48 23	V-G G-V				

Table 22-14
NT8D15AA E&M Trunk Card 4W Type 1 mode pair
terminations for I/O panel connector A

Pair	Pin	Pair Color	I/O Panel Connector	Unit Number	
			A		
TA TB	26 1	W-BL BL-W	S L O T 0	Unit 0	
RA RB	27 2	w-o o-w			
E M	28 3	W-G G-W			
ESC ESCG	29 4	W-BR BR-W			
TA TB	30 5	w-s s-w		S L O T	Unit 1
RA RB	31 6	R-BL BL-R			
E M	32 7	R-O O-R			
ESC ESCG	33 8	R-G G-R			
TA TB	34 9	R-BR BR-R		0	Unit 2
RA RB	35 10	R-S S-R			
E M	36 11	BK-BL BL-BK			
ESC ESCG	37 12	BL-0 0-BK			
TA TB	38 13	BK-G G-BK		0	Unit 3
RA RB	39 14	BK-BR BR-BK			
E M	40 15	BK-S S-BK			
ESC ESCG	41 16	Y-BL BL-Y			

Note: The cable pair designated TA, 1 is the transmit pair. The cable pair designated RA, RB is the receive pair.

Table 22-15
NT8D15AA E&M Trunk Card 4W Type 1 mode pair
terminations for I/O panel connectors B,E,H

Pair	Pin	Pair Color	I/O Panel Connector			Unit Number
			B	E	H	
TA TB	26 1	W-BL SL-w				Unit 0
RA RB	27 2	W - o o - w				
E M	26 3	W - G G - W				
ESC ESCG	29 4	W - BR BR - W				
TA TB	30 5	W-S s - w				Unit 1
RA RB	31 6	R-BL BL-R				
E M	32 7	R-O O-R	S L O T	S L O T	S L O T	
ESC ESCG	33 6	R-G G-R				
TA TB	3 4 9	R-BR BR-R	1	4	7	Unit 2
RA RB	35 10	R-S S-R				
E M	36 11	BK-BL BL-BK				
ESC ESCG	37 12	BL-0 0-BK				
TA TB	38 13	BK-G G-BK				Unit 3
RA RB	39 14	BK-BR BR-BK				
E M	40 15	BK-S S-BK				
ESC ESCG	41 16	Y-EL BL-Y				
TA TB	4 2 17	Y-O O-Y				Unit 0
RA RB	43 16	Y-G G-Y				
E M	44 19	Y-BR BR-Y	S L O T	S L O T	S L O T	
ESC ESCG	45 20	Y-S S-Y				
TA TB	46 21	V-BL BL-V	2	5	6	Unit 1
RA RB	47 22	v - o o - v				
E M	48 23	V-G G-V				
ESC ESCG	49 24	V-BR BR-V				

Note: The pair designated TA, TB is the transmit pair. The pair designated RA, RB is the receive pair.

Table 22-16
NT8D15AA E&M Trunk Card 4W Type 1 mode pair
 terminations for I/O panel connectors C,F,K

Pair	Pins	Pair Color	I/O Panel Connector			Unit Number			
			C	F	K				
TA TB	26 1	W-BL BL-W	S L O T 2	S L O T 5	S L O T 6	Unit 2			
RA RB	27 2	W-O O-W							
E M	28 3	W-G G-W							
ESC ESCG	29 4	W-BR BR-W							
TA TB	30 5	W-S S-W				S L O T 3	S L O T 6	S L O T 9	Unit 3
RA RB	31 6	R-BL BL-R							
E M	32 7	R-O O-R							
ESC ESCG	33 8	R-G G-R							
TA TB	34 9	R-BR BR-R	S L O T 3	S L O T 6	S L O T 9				Unit 0
RA RB	35 10	R-S S-R							
E M	36 11	BK-BL BL-BK							
ESC ESCG	37 12	BL-O O-BK							
TA TB	38 13	BK-G G-BK				S L O T 3	S L O T 6	S L O T 9	Unit 1
RA RB	39 14	BK-BR BR-BK							
E M	40 15	BK-S S-BK							
ESC ESCG	41 16	Y-BL BL-Y							
TA TB	42 17	Y-O O-Y	S L O T 3	S L O T 6	S L O T 9				Unit 2
RA RB	43 18	Y-G G-Y							
E M	44 19	Y-BR BR-Y							
ESC ESCG	45 20	Y-S S-Y							
TA TB	46 21	V-BL BL-V				S L O T 3	S L O T 6	S L O T 9	Unit 3
RA RB	47 22	v-o o-v							
E M	48 23	V-G G-V							
ESC ESCG	49 24	V-BR BR-V							

Note: The cable pair designated T, A ... is the transmit pair. The pair designated RA, RB is the receive pair.

Table 22-17
NT8D15AA E&M Trunk Card 4W Type 2 mode pair
terminations for I/O panel connector A

Pair	Pin	Pair Color	I/O Panel Connector	Unit Number
			A	
TA	26	W-BL	S L 0 T 0	Unit 0
TB	1	BL-W		
RA	27	w - o		
RB	2	o - w		
EA	26	W-G		Unit 1
SG	3	G-W		
MA	29	W-BR		
BB	4	BR-W		
TA	30	w - s		Unit 2
TB	5	s - w		
RA	31	R-BL		
RB	6	BL-R		
EA	32	R-O		Unit 3
SG	7	O-R		
MA	33	R-G		
BB	8	G-R		
TA	3 4	R-BR	S L 0 T 0	Unit 2
TB	9	BR-R		
RA	35	R-S		
RB	10	S-R		
EA	36	BK-BL		Unit 3
SG	11	BL-BK		
MA	37	BL-0		
BB	12	0-BK		
TA	38	BK-G		Unit 3
TB	13	G-BK		
RA	39	BK-BR		
RB	14	BR-BK		
EA	40	BK-S		
SG	15	S-BK		
MA	41	Y-BL		
BB	16	BL-Y		

Note: The cable pair designated TA, 1B is the transmit pair. The pair designated RA, RB is the receive pair.

Table 22-18
NT8D15AA E&M Trunk Card 4W Type 2 mode pair
terminations for I/O panel connectors B,E,H

Pair	Pin	Pair Color	I/O Panel connector			Unit Number
			B	E	H	
TA TB RA RB EA SG MA BB	26 1 27 2 28 3 29 4	W-BL BL-W w - o o - w W - G G - W W - BR BR - W				Unit 0
TA TB RA RB EA SG MA BB	30 5 31 6 32 7 33 8	W-S S - w R - BL BL - R R - O O - R R - G G - R	S L O T	S L O T	S L O T	Unit 1
TA TB RA FIB EA SG MA BB	3 4 9 35 10 36 11 37 12	R-BR BR - R R - S S - R BK - BL BL - BK BL - O O - BK	t	4	7	Unit 2
TA TB RA RB EA SG MA BB	38 13 39 14 40 15 41 16	BK-G G - BK BK - BR BR - BK BK - S S - BK Y - BL BL - Y				Unit 3
TA TB RA RB EA SG MA BB	42 17 43 18 44 19 45 20	Y - O O - Y Y - G G - Y Y - BR BR - Y Y - S S - Y	S L O T	S L O T	S L O T	Unit 0
TA TB RA RB EA SG MA BB	46 21 47 22 48 23 49 24	V-BL BL - V v - o o - v V - G G - V V - BR BR - V	2	5	8	Unit 1
Note: The color pair designated TA, is transmit pair. The pair designated RA, RB is the receive pair.						

Table 22-19
NT8D15AA E&M Trunk Card 4W Type 2 mode pair
terminations for I/O panel connectors C,F,K

Pair	Pins	Pair Color	I/O Panel Connector			Unit Number
			C	F	K	
TA TB	26 1	W-BL BL-W	S L O T 2	S L O T 5	S L O T 6	Unit 2
RA RB	27 2	w - o o - w				
EA SG	26 3	W - G G - W				
MA BB	29 4	W-BR BR-W				
TA TB	30 5	W-S S-W				
RA RB	31 6	R-BL BL-R				
EA SG	32 7	R-O O-R				Unit 3
MA BB	33 8	R-G G-R				
TA TB	34 9	R-BR BR-R				
RA RB	35 10	R-S S-R				
EA SG	36 11	BK-BL BL-BK				
MA BB	37 12	BL-O O-BK				
TA TB	38 13	BK-G G-BK	S L O T 3	S L O T 6	S L O T 0	unit 0
RA RB	39 14	BK-BR BR-BK				
EA SG	40 15	BK-S S-BK				
MA BB	41 16	Y-BL BL-Y				
TA TB	42 17	Y-O O-Y				
RA RB	43 18	Y-G G-Y				
EA SG	44 19	Y-BR BR-Y				
MA BB	45 20	Y-S S-Y				
TA TB	46 21	V-BL BL-V				
RA RB	47 22	V-O O-V				
EA SG	48 23	V-G G-V	Unit 1			
MA BB	49 24	V-BR BR-V				

Not.: The cable pair designated TA, TB is the transmit pair. The pair designated RA, RB is the receive pair.



1



Procedure 23

Cabling NT8D37 and NT8D13 PE modules to the cross-connect terminal

General information

Use this procedure to install cables to the cross connect terminal from NT8D37 and NT8D13 Peripheral Equipment modules.

Each NT8D37 or NT8D13 PE module is equipped with a series of connectors mounted on the I/O panel at the rear of the module which extend the pins from the peripheral equipment card slots in the module. These I/O connectors are connected to the cross-connect terminal with NE-A25B type cables.

Cable installation

- 1 Select an appropriate number of NE-A25B type cables of sufficient length to reach from the I/O connector panel of the PE module to the cross-connect terminal.
 - Figure 23-1 illustrates the left and right I/O connector panels on the rear of the NT8D37 PE module.
 - Figure 23-2 illustrates the left and right I/O connector panels on the rear of the NT8D13 PE module.
- 2 Designate both ends of each cable with a cable tag indicating PE module number and I/O connector designation.
- 3 Connect the cables to the appropriate connectors on the I/O panel and run the cables to the cross-connect terminal.
- 4 Terminate the cables from the PE module on the cross-connect **block** designated with the appropriate PE module number.

Note: *The* terminal blocks for PE modules are located on all rows except the bottom row on the horizontal side of the main cross-connect terminal when **frame** mounted blocks are used, or in the white field when wall mounted blocks are **used**. **See Procedure 16: Designating the cross-connect terminal**, for more details.

- 5 Repeat steps 1 through 4 for all PE modules provisioned.
- 6 All cables must be neatly run, properly seated, and secured with cable ties.

Figure 23-1
NT8D37 PE Module I/O panels

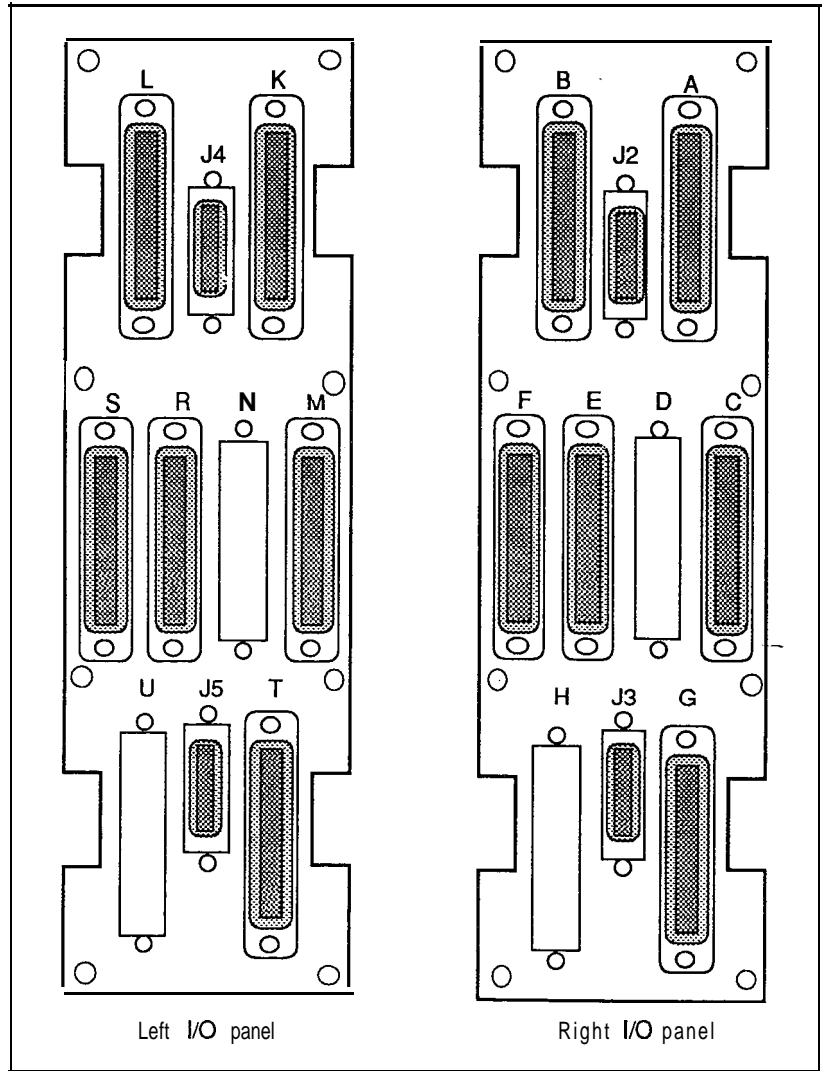
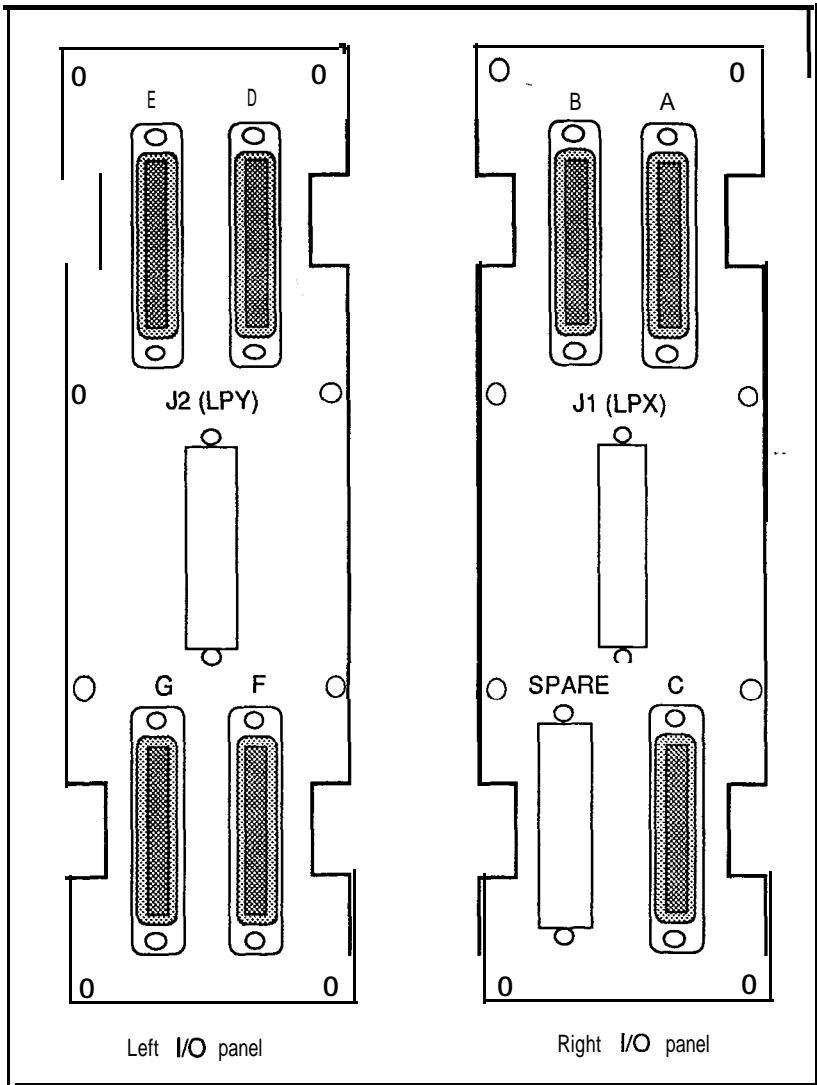

Figure 23-2
NT8D13 PE Module I/O panels



Procedure 24: Connecting lines and trunks at the cross-connect terminal

General information

Use this procedure to cross-connect lines and trunk served by peripheral equipment cards in **NT8D37** or **NT8D13** PE modules. For cross-connect information for **NT8D11 CE/PE** modules, *see Procedure 22: Cabling NT8D11 CE/PE modules to the cross-connect terminal.*

Connecting lines and trunks

Extend incoming wiring (such as the cable from the central office or wiring from a recorded announcement machine) to the system's cross-connect terminal and terminate on separate connecting blocks before beginning this procedure.

Assign and record terminal numbers (TNs) for each line or trunk connected to the system.

- 1 From the work order or assignment records, determine the location of the line or trunk connection and its assigned TN.
- 2 Using cross-connecting wire (typically 24 gauge type-Z wire) connect the line or trunk to the TN, making sure that wiring is not reversed and is on the proper terminals. Allow enough slack in the wiring to reconnect wires if they break at the terminal and to facilitate tracing.
 - Tables 24-1 through 24-3 illustrate the pair-termination assignments for **NT8D02AA**, **NT8D03AA**, and **NT8D09AA** line cards in **NT8D37** PE modules.
 - Tables 24-4 through 24-7 illustrate the pair-termination assignments for line cards in **NT8D13** PE modules.
 - Tables 24-8 through 24-16 illustrate the pair-termination assignments for the **NT8D15AA** E&M Trunk Card.
 - Tables 24-17 through 24-19 illustrate the pair-termination assignments for the **NT8D14AA** Universal Trunk Card.
 - See Tables 24-20 through 24-27 to connect trunks housed in **NT8D13** PE Modules.

Table 24-1
Pair-terminations for NT8D37 PE Module I/O panel connectors A,E,K,R

Pair	Pins	Pair Color	I/O Panel Connector				Unit Number
			A	E	K	R	16 Units Per Card
1T 1R	26 1	W-BL BL-W	S L O T 0	S L O T 4	S L O T 8	S L O T 12	Unit 0
2T 2R	27 2	w-o o-w					Unit 1
3T 3R	28 3	W-G G-W					Unit 2
4T 4R	29 4	W-BR BR-W					Unit 3
5T 5R	30 5	w-s s-w					Unit 4
6T 6R	31 6	R-BL BL-R					Unit 5
7T 7R	32 7	R-O O-R					Unit 6
8T 8R	33 8	R-G G-R					Unit 7
9T 9R	34 9	R-BR BR-R					Unit 8
10T 10R	35 10	R-S S-R					Unit 9
11T 11R	36 11	BK-BL BL-BK					Unit 10
12T 12R	37 12	EL-O O-BK					Unit 11
13T 13R	38 13	BK-G G-BK					Unit 12
14T 14R	39 14	BK-BR BR-BK					Unit 13
15T 15R	40 15	BK-S S-BK					Unit 14
16T 16R	41 16	Y-BL BL-Y					Unit 15

Table 24-2
Pair-terminations for NT8D37 PE Module I/O panel connectors B,F,L,S

Pair	Pins	Pair Color	I/O Panel Connector				Unit Number
			B	F	L	S	
1T 1R	26 1	W-BL BL-W	S L O T 1	S L O T 5	S L O T 9	S L O T 13	16 Units Per Card
2T 2R	27 2	W-O O-W					Unit 0
3T 3R	28 3	W-G G-W					Unit 1
4T 4R	29 4	V-BR BR-W					Unit 2
5T 5R	30 5	W-S S-W					Unit 3
6T 6R	31 6	R-BL BL-R					Unit 4
7T 7R	32 7	R-O O-R					Unit 5
8T 8R	33 8	R-G G-R					Unit 6
9T 9R	34 9	R-BR BR-R					Unit 7
10T 10R	35 10	R-S S-R					Unit 8
11T 11R	36 11	BK-BL BL-BK					Unit 9
12T 12R	37 12	BL-O O-BK					Unit 10
13T 13R	38 13	BK-G G-BK					Unit 11
14T 14R	39 14	BK-BR BR-BK					Unit 12
15T 15R	40 15	BK-S S-BK					Unit 13
16T 16R	41 16	Y-BL BL-Y					Unit 14
17T 17R	42 17	Y-O O-Y	Unit 15				
18T 18R	43 18	Y-G G-Y	Unit 0				
19T 19R	44 19	Y-BR BR-Y	Unit 1				
20T 20R	45 20	Y-S S-Y	Unit 2				
21T 21R	46 21	V-BL BL-V	Unit 3				
22T 22R	47 22	v-o o-v	Unit 4				
23T 23R	48 23	V-G G-V	Unit 5				
24T 24R	49 24	V-BR SR-V	Unit 6				
25R 25T	50 25	v-s s-v	Unit 7				
			Spare				

Table 24-3
Pair-terminations for NT8D37 PE Module I/O panel connectors C,G,M,T

Pair	Pins	Pair Color	I/O Panel Connector				Unit Number
			C	G	M	T	16 Units Per Card
1T 1R	26 1	W-BL BL-W					Unit 8
2T 2R	27 2	W-O O-W					Unit 9
3-r 3R	26 3	W-G G-W					Unit 10
4T 4R	29 4	W-BR BR-W	S L	S L	S L	S L	Unit 11
5-r 5R	30 5	W-S S-W	0 T	0 T	0 T	0 T	Unit 12
6T 6R	31 6	R-BL EL-R	2	6	10	14	Unit 13
7R	32	U-R-R-U					Unit 14
8T 8R	33 6	R-G G-R					Unit 15
9T 9R	34 9	R-BR BR-R					Unit 0
10T 10R	35 10	R-S S-R					Unit 1
11T 11R	36 11	BK-BL BL-BK					Unit 2
12-r 12R	37 12	BL-O O-BK					Unit 3
13T 13R	38 13	BK-G G-BK					Unit 4
14T 14R	39 14	BK-BR BR-BK					Unit 5
15T 15R	40 15	BK-S S-BK	S L	S L	S L	S L	Unit 6
16T 16R	41 16	Y-BL BL-Y	0 T	0 T	0 T	0 T	Unit 7
17T 17R	42 17	Y-O O-Y	3	7	11	15	Unit 8
18T 18R	43 18	Y-G G-Y					Unit 9
19T 19R	44 19	Y-BR BR-Y					Unit 10
20T 20R	45 20	Y-S S-Y					Unit 11
21T 21R	46 21	V-BL BL-V					Unit 12
22T 22R	47 22	V-O O-V					Unit 13
23T 23R	48 23	V-G G-V					Unit 14
24T 24R	49 24	V-BR BR-V					Unit 15
25R	50	V-S					Spare
25T	25	S-V					

Table 24-4
Pair-terminations for NT8D13 PE Module I/O panel connectors A,C,E,G (Single Loop Mode)

Paw	Pins	Pew Color	I/O Panel connector				Unit Number																							
			A	C	E	G	16 Units Per Card	8 Units Per Card	4 Units Per Card	2 Units Per Card																				
1T	26	W-BL	S L O T	S L O T	S L O T	S L O T	Unit 0	Unit 0	Unit 0	Unit 0																				
1R	1	BL-W					Unit 8																							
2T	27	W-O					Unit 1																							
2R	2	O-W					Unit 9																							
3T	28	W-G					X-1	x-4	x-7	K-11	Unit 2	Unit 2	Unit 1	Unit 1																
3R	3	G-W									Unit 10																			
4T	29	W-BR									C A R D	C A R D	C A R D	C A R D	Unit 3	Unit 3	Unit 3	Unit 3												
4R	4	BR-W													Unit 11															
5T	30	W-S													1				4	7	IO	Unit 4								
5R	5	S-W														Unit 12														
6T	31	R-BL														Unit 13														
6R	6	BL-R														Unit 14														
7T	32	R-O														Unit 15														
7R	7	O-R														Unit 6														
8T	33	R-G														Unit 14														
8R	8	G-R														Unit 7														
9T	34	R-BR	S P A R E	x-5	x-8	S P A R E										Unit 8	Unit 0	Unit 0				Unit 0								
9R	9	BR-R														Unit 9														
10T	135	R-S														X-2	x-5	x-8				S P A R E	Unit 1	Unit 1	Unit 1	Unit 1				
10R	10	S-R																					Unit 2							
11T	36	BK-BL					C A R D	C A R D	C A R D	C A R D													Unit 3	Unit 3	Unit 3	Unit 3				
11R	11	BL-BK																					Unit 10							
12T	37	BL-O									Unit 11																			
12R	12	O-BK									Unit 3																			
13T	38	BK-G									2	5	8	S P A R E	Unit 14				Unit 2	Unit 1	Unit 1									
13R	13	G-BK													Unit 7															
14T	39	BK-BR													S p a r e				x-5	x-8	S p a r e		Unit 15	Unit 3	Unit 3	Unit 3				
14R	14	BR-BK																					Unit 2							
15T	40	BK-S																					2	5	8	S p a r e	Unit 14	Unit 1	Unit 1	Unit 1
15R	15	S-BK																									Unit 3			
16T	41	Y-BL																									Unit 11			
16R	16	BL-Y																									S p a r e	x-5	x-8	S p a r e
17T	42	Y-O	Unit 2																											
17R	17	O-Y	Unit 10																											
18T	43	Y-G	2	5	8	S p a r e										Unit 8	Unit 0	Unit 0				Unit 0								
18R	18	G-Y														Unit 9														
19T	44	Y-BR					C A R D	C A R D	C A R D	C A R D						Unit 1	Unit 2	Unit 1				Unit 1								
19R	19	BR-Y														Unit 2														
20T	45	Y-S														Unit 10														
20R	20	S-Y														Unit 3														
21T	46	V-BL									2	5	8	S p a r e		Unit 11	Unit 3	Unit 3				Unit 3								
21R	21	BL-V														Unit 2														
22T	47	V-O													S p a r e	x-5	x-8	S p a r e	Unit 3	Unit 1	Unit 1	Unit 1								
22R	22	O-V																	Unit 11											
23T	48	V-G																	Unit 11											
23R	23	G-V																	S p a r e	x-5	x-8	S p a r e	Unit 11	Unit 3	Unit 3	Unit 3				
24T	49	V-BR																					Unit 2							
24R	24	BR-V																					Unit 11							
25R	50	V-S																					S p a r e	x-5	x-8	S p a r e	Unit 11	Unit 3	Unit 3	Unit 3
25T	25	S-V																									Unit 2			

Table 24-5

Pair-terminations for NT8D13 PE Module I/O panel connectors B,D,F (Single Loop Mode)

Pair	Pine	Pair Color	I/O Panel Connector			Unit Number				
			B	D	F	16 Units Per Card	8 Units Per Card	4 Units Per Card	2 Units Per Card	
1T 1R	26 1	W-BL BL W	S L O T	S L O T	s L L	Unit 4	Unit 4	Unit 2		
2T 2R	27 2	W-O O-W				Unit 12				
3T 3R	28 3	W-G G-W				Unit 13	Unit 5			
4T 4R	29 4	W-BR BR-W				Unit 6				
5T 5R	30 5	W-S S-W				Unit 14	Unit 6			
6T 6R	31 16	R-BL BL-R				Unit 7				
7T 7R	32 7	R-O O-R	C A R D	C A R D	C A R D	Unit 15	Unit 7	Unit 3		
8T 8R	33 8	R-G G-R				2				5
9T 9R	34 9	R-BR BR-R	S L O T	S L O T	S L O T	Unit 0	Unit 0	Unit 0	Unit 0	
10T 10R	35 10	R-S S-R				Unit 8				
11T 11R	36 11	BK-BL BL-BK				Unit 1	Unit 1			
12T 12R	37 12	BL-O O-BK				Unit 9				
13T 13R	38 13	C-G G-BK	X-3	X-6	x-9	Unit 2	Unit 2	Unit 1	Unit 1	
14T 14R	39 14	BK-BR BR-BK				Unit 10				
15T 15R	40 15	BK-S S-BK	C A R D	C A R D	C A R D	Unit 3	Unit 3	Unit 1		
16T 16R	41 16	Y-BL BL-Y				Unit 11				
17T 17R	42 17	Y-O O-Y	3	6	9	Unit 4	Unit 4	Unit 2		
18T 18R	43 18	Y-G G-Y				Unit 12				
19T 19R	44 19	Y-BR BR-Y	C A R D	C A R D	C A R D	Unit 5	Unit 5	Unit 2		
20T 20R	45 20	Y-S S-Y				Unit 13				
21T 21R	46 21	V-BL BL-V	C A R D	C A R D	C A R D	Unit 6	Unit 6	Unit 3		
22T 22R	47 22	V-O O-V				Unit 14				
23T 23R	48 23	V-G G-V	C A R D	C A R D	C A R D	Unit 7	Unit 7	Unit 3		
24T 24R	49 24	V-BR BR-V				Unit 15				
25R 25T	50 25	v-s s-v	Spare							

Table 24 - 6
Pair-terminations for NT8D13 PE Module I/O panel connectors A,C,E,G
(Dual Loop Mode)

Pair	Pins	Pair Color	I/O Panel Connector				Unit Number			
			A	C	E	G	16 Units Per Card	8 Units Per Card	4 Units Per Card	2 Units Per Card
1T 1R	26 1	W-BL BL-W	S L O T	S L O T	S L O T	S L O T	Unit 0	Unit 0	Unit 0	Unit 0
2T 2R	27 2	W-O O-W					Unit 8			
3T 3R	28 3	W-G G-W					Unit 1			
4T 4R	29 4	W-BR BR-W					Unit 9			
5T 5R	30 5	W-S S-W	X-1	x-4	Y-2	Y-5	Unit 2	Unit 1	Unit 1	
6T 6R	31 6	R-BL BL-R	C A R D	C A R D	C A R D	C A R D	Unit 10			
7T 7R	32 7	R-O O-R					Unit 3			
8T 8R	33 8	R-G G-R					Unit 11			
9T 9R	34 9	R-BR BR-R					Unit 4			
10T 10R	35 10	R-S S-R	1	4	2	5	Unit 12	Unit 2	Unit 3	
11T 11R	36 11	BK-BL BL-BK					Unit 5			
12T 12R	37 12	BL-O O-BK					Unit 13			
13T 13R	38 13	BK-G G-BK					Unit 6			
14T 14R	39 14	BK-BR BR-BK	14	14	14	14	Unit 14	Unit 3	Unit 1	
15T 15R	40 15	BK-S S-BK					Unit 7			
16T 16R	41 16	Y-BL BL-Y					Unit 7			
17T 17R	42 17	Y-O O-Y					Unit 15			
18T 18R	43 18	Y-G G-Y	S L O T	S L O T	S L O T	S P A R E	Unit 0	Unit 0	Unit 0	
19T 19R	44 19	Y-BR BR-Y					Unit 8			
20T 20R	45 20	Y-S S-Y	x-2	x-5	Y-3	S P A R E	Unit 1	Unit 1	Unit 1	
21T 21R	46 21	V-BL BL-V	C A R D	C A R D	C A R D		C A R D			Unit 9
22T 22R	47 22	V-O O-V						Unit 2		
23T 23R	48 23	V-G G-V						Unit 10		
24T 24R	49 24	V-BR BR-V				Unit 3				
25T	50 25	v-s s-v	2	5	3	Spare				

Table 24-7
Pair-terminations for NT8D13 PE Module I/O panel connectors B,D,F
(Dual Loop Mode)

Pair	Pins	Pair Color	I/O Panel Connector			Unit Number			
			B	D	F	16 Units Per Card	8 Units Per Card	4 Units Per Card	2 Units Per Card
1T	26	W-BL	S L O T	S L O T	S L O T	Unit 4	Unit 4	Unit 2	
1R	1	BL-W				Unit 4			
2T	27	W-O				Unit 12			
2R	2	O-W				Unit 5			
3T	28	W-G	x - 2	X-5	Y-3	Unit 13	Unit 5		
3R	3	G-W				Unit 6			
4T	29	W-BR				Unit 14			
4R	4	BR-W				Unit 7			
5T	30	W-S	C A R D	C A R D	C A R D	Unit 15	Unit 6	Unit 3	
5R	5	S-W				Unit 7			
6T	31	R-BL				Unit 14			
6R	6	BL-R				Unit 15			
7T	32	R-O	2	5	3	Unit 0	Unit 0	Unit 0	
7R	7	O-R				Unit 8			
8T	33	R-G				Unit 1			
8R	8	G-R				Unit 9			
9T	34	R-BR	S L O T	S L O T	S L O T	Unit 2	Unit 0	Unit 0	
9R	9	BR-R				Unit 1			
10T	35	R-S				Unit 10			
10R	10	S-R				Unit 11			
11T	36	BK-BL	x-3	Y-1	Y-4	Unit 2	Unit 1	Unit 1	
11R	11	BL-BK				Unit 3			
12T	37	BL-O				Unit 10			
12R	12	O-BK				Unit 11			
13T	38	BK-G	C A R D	C A R D	C A R D	Unit 4	Unit 3	Unit 2	
13R	13	G-BK				Unit 12			
14T	39	BK-BR				Unit 13			
14R	14	BR-BK				Unit 14			
15T	40	BK-S	3	1	4	Unit 3	Unit 4	Unit 2	
15R	15	S-BK				Unit 4			
16T	41	Y-BL				Unit 11			
16R	16	BL-Y				Unit 12			
17T	42	Y-O	C A R D	C A R D	C A R D	Unit 5	Unit 5	Unit 3	
17R	17	O-Y				Unit 6			
18T	43	Y-G				Unit 13			
18R	18	G-Y				Unit 14			
19T	44	Y-BR	3	1	4	Unit 4	Unit 4	Unit 2	
19R	19	BR-Y				Unit 5			
20T	45	Y-S				Unit 12			
20R	20	S-Y				Unit 13			
21T	46	V-BL	C A R D	C A R D	C A R D	Unit 3	Unit 3	Unit 3	
21R	21	BL-V				Unit 4			
22T	47	V-O				Unit 11			
22R	22	O-V				Unit 12			
23T	48	V-G	2	3	4	Unit 5	Unit 5	Unit 2	
23R	23	G-V				Unit 6			
24T	49	V-BR				Unit 13			
24R	24	BR-V				Unit 14			
25R	50	v-s	S p a r e			Unit 7	Unit 7		
25T	25	s-v				Unit 15			

Table 24-8
NT8D15AA E&M P-Wire Type 1 connections for NT8D37
I/O panel connectors A,E,K,R

Pair	Pins	Pair Color	I/O Panel Connector				Unit Number
			A	E	K	R	
T0 RO	26 1	w-BL BL-W	S L O T 0	S L O T 4	S L O T 8	S L O T 12	Unit 0
E M	28 3	W-G G-W					
T1 R1	30 5	w - s s-w					
E M	32 7	R-O O-R					
T2 R2	34 9	R-BR BR-R					
E M	36 11	BK-BL BL-BK					
T3 R3	38 13	BK-G G-BK					
E M	40 15	BK-S S-BK					Unit 3

Table 24-9
NT8D15AA E&M P-Wire Type 1 connections for INT8D37
I/O panel connectors B,F,L,S

Pair	Pins	Pair Color	I/O Panel Connector				Unit Number
			B	F	L	S	
T0 R0	26 1	W-BL BL-W					Unit 0
E M	28 3	W-G G-W					
T1 R1	30 5	w-s s-w	s	S	s	S	Unit 1
E M	32 7	R-O O-R	L O	L O	L O	L O	
T2 R2	34 9	R-BR BR-R	T	T	T	T	Unit 2
M	33	BK-BL BL-BK	1	5	9	13	
i-3 R3	38 13	BK-G G-BK					Unit 3
M	41	S-BK BK-S					
T0 R0	42 17	Y-O O-Y	S	S	S	S	Unit 0
E M	44 19	Y-BR BR-Y	L O	L O	L O	L O	
i-1 R1	46 21	V-BL BL-V	T	T	T	T	Unit 1
M	28	G-G	2	6	10	14	

Table 24-10
NT8D15AA E&M 2-Wire Type 1 trunk connections for NT8D37
I/O panel connectors C,G,M,T

Pair	Pins	Pair Color	I/O Panel Connector				Unit Number
			C	G	M	T	
T2 R2	26 1	W-BL BL-W	S	S	S	S	Unit 2
E M	28 3	W-G G-W	L 0	L 0	L 0	L 0	
T3 R3	30 5	w-s s-w	T	T	T	T	Unit 3
E M	32 7	R-O O-R	2	6	10	14	
T0 R0	3 9	R-BR BR-R					Unit 0
E M	36 11	BK-BL BL-BK					
T1 R1	38 13	BK-G G-BK	S	S	S	S	Unit 1
E M	40 15	BK-S S-BK	L 0	L 0	L 0	L 0	
T2 R2	42 17	Y-O O-Y	T	T	T	T	Unit 2
E M	44 19	Y-BR BR-Y	3	7	11	15	
T3 R3	46 21	V-BL BL-V					Unit 3
E M	48 23	V-G G-V					

24-12 Connecting lines and trunks at the **cross-connect** terminal

Table 24-11

NT8D15AA E&M P-Wire Paging trunk connections for NT8D37 I/O panel connectors A,E,K,R

Pair	Pins	Pair Color	I/O Panel Connector				Unit Number
			A	E	K	R	
TO R0	26 1	W-BL BL-W	S L O T 0	S L O T 4	S L O T 8	S L O T 12	Unit 0
A PG	29 4	W-BR BR-W					Unit 1
T1 R1	30 5	w-s s-w					Unit 2
A PG	33 8	R-G G-R					Unit 3
T2 R2	34 9	R-BR BR-R					
A PG	37 12	BL-O O-BL					
T3 R3	38 13	BK-G G-BK					
A PG	41 16	Y-BL BL-Y					

Table 24-12

NT8D15AA E&M P-Wire Paging trunk connections for NT8D37
I/O panel connectors B,F,L,S

Panel	Pins	Pair Color	I/O Panel Connector				Unit Number
			B	F	L	S	
T0 R0	26 1	W-BL BL-W					Unit 0
A PG	29 4	W-BR BR-W					
T1 R1	30 5	w-s s-w	S	S	S	S	Unit 1
A PG	33 8	R-G G-R	L O	L O	L O	L O	
T2 R2	34 9	R-BR BR-R	T	T	T	T	Unit 2
A PG	37 12	BL-0 0-BL	1	5	9	13	
T3 R3	38 13	BK-G G-BK					Unit 3
A PG	41 16	Y-BL BL-Y					
T0 R0	42 17	Y-O O-Y	S	S	S	S	Unit 0
A PG	45 20	Y-S S-Y	L O	L O	L O	L O	
T1 R1	46 21	V-BL BL-V	T	T	T	T	Unit 1
A PG	49 24	V-BR BR-V	2	6	10	14	

24-14 Connecting lines and trunks at the cross-connect terminal

Table 24-13

NT8D15AA E&M P-Wire Paging trunk connections for NT8D37 I/O panel connectors C,G,M,T

Pair	Pins	Pair Color	I/O Panel Connector				Unit Number
			C	G	M	T	
T2 R2	26 1	W-BL BL-W	S	S	S	S	Unit 2
A PG	29 4	W-BR BR-W	L O	L O	L O	L O	
T3 R3	30 5	w-s s-w	T	T	T	T	Unit 3
A PG	33 8	R-G G-R	2	6	10	14	
TO RO	34 9	R-BR BR-R					Unit 0
A PG	37 12	BL-0 0-BL					
T1 R1	38 13	BK-G G-BK	S	S	S	S	Unit 1
A PG	41 16	Y-BL BL-Y	L O	L O	L O	L O	
T2 R2	42 17	Y-O O-Y	T	T	T	T	Unit 2
A PG	45 20	Y-S S-Y	3	7	11	15	
T3 R3	46 21	V-BL BL-V					Unit 3
A PG	49 24	V-BR BR-V					

Table 24-14
NT8D15AA E&M 4-Wire Type 1 & Type 2 connections for NT8D37
I/O panel connectors A,E,K,R

Lead designations		Pin	Pair Color	I/O Panel Connector				Unit Number
Type 1 mode	Type 2 mode			A	E	K	R	
TA TB	TA TB	26 1	W-BL BL-W					Unit 0
RA FIB	RA RB	27 2	w-o o-w					
E M	EA SG	28 3	W-G G-W					
ESC ESCG	MA BB	29 4	W-BR BR-W					
TA TB	TA TB	30 5	w-s s-w					Unit 1
RA RB	RA RB	31 6	R-BL BL-R					
E M	EA SG	32 7	R-O O-R	S L O T	S L O T	S L O T	S L O T	
ESC ESCG	MA BB	33 8	R-G G-R					
TA TB	TA TB	34 9	R-BR BR-R	0	4	8	12	Unit 2
RA RB	RA RB	35 10	R-S S-R					
E M	EA SG	36 11	BK-BL BL-BK					
ESC ESCG	MA BB	37 12	BL-0 0-BK					
TA TB	TA TB	38 13	BK-G G-BK					Unit 3
RA RB	RA RB	39 14	BK-BR BR-BK					
E M	EA SG	40 15	BK-S S-BK					
ESC ESCG	MA BB	41 16	Y-BL BL-Y					

Note: The cable pair designated TA, TB is the transmit pair.
 The pair designated RA, RB is the receive pair.

Table 24-15
NT8D15AA E&M 4-Wire Type 1 & Type 2 connections for NT8D37
I/O panel connectors B,F,L,S

Lead designations		Pin	Pair Color	I/O Panel Connector				Unit Number
Type 1 mode	Type 2 mode			B	F	L	S	
TA TB	TA TB	26	W-BL BL-W					Unit 0
RA RB	RA RB	27 2	w-o o-w					
E M	EA SG	28 3	W-G G-W					
ESC ESCG	MA 6 6	29 4	W-BR BR-W					
TA TB	TA TB	30	W-S S-W					Unit 1
RA RB	RA RB	31 6	R-BL BL-R	S L O T	S L O T	S L O T	S L O T	
E M	EA SG	32 7	R-O O-R					
ESC ESCG	MA 6 6	33 8	R-G G-R					
TA TB	TA TB	34 9	R-BR BR-R					1
RA RB	RA RB	35 10	R-S S-R					
E M	EA SG	38 11	BK-BL BL-BK					
ESC ESCG	MA 6 6	37 12	BL-O O-BK					
TA TB	TA TB	38 3	BK-G G-BK					Unit 3
RA RB	RA RB	39 14	BK-BR BR-BK					
E M	EA SG	40 15	BK-S S-BK					
ESC ESCG	MA 6 6	41 16	Y-BL BL-Y					
TA TB	TA TB	42 4	Y-O O-Y					unit 0
RA RB	RA RB	43 18	Y-Q G-Y	S L O T	S L O T	S L O T	S L O T	
E M	EA SG	44 19	Y-BR BR-Y					
ESC ESCG	MA 6 6	45 20	Y-S S-Y					
TA TB	TA TB	46 21	V-BL BL-V					2
RA RB	RA RB	47 22	v-o o-v					
E M	EA SG	48 23	V-G G-V					
ESC ESCG	MA 6 6	49 24	V-BR BR-V					

Note: The pair designated RA, RB is the receive pair. The pair designated EA, EG is the transmit pair.

Table 24-16

NT8D15AA E&M 4-Wire Type 1 & Type 2 connections for NT8D37 I/O panel connectors C,G,M,T

Lead designations			Pins	Pair Color	I/O Panel Connector				Unit Number
RAN mode	Paging mode	All other modes			C	G	M	T	
T0 R0	T0 R0	T0 R0	26 1	W-BL BL-W	S L O T 2	S L O T 6	S L O T 10	S L O T 14	Unit 4
CP MB	A PG		27 2	W-O O-W					
T1 R1	T1 R1	T1 R1	28 3	W-G G-W					
CP MB	A PG		29 4	W-BR BR-W					
T2 R2	T2 R2	T2 R2	30 5	W-S S-W					
CP MB	A PG		31 6	R-BL BL-R					
T3 R3	T3 R3	T3 R3	32 7	R-O O-R					
CP MB	A PG		33 8	R-G G-R					
T4 R4	T4 R4	T4 R4	34 9	R-BR BR-R	S L O T 3	S L O T 7	S L O T 11	S L O T 15	Unit 0
CP MB	A PG		35 10	R-S S-R					
T5 R5	T5 R5	T5 R5	36 11	BK-BL BL-BK					
CP MB	A PG		37 12	BK-S S-BK					
T6 R6	T6 R6	T6 R6	38 13	BK-G G-BK					
CP MB	A PG		39 14	BK-BR BR-BK					
T7 R7	T7 R7	T7 R7	40 15	BK-O S-BK					
CP MB	A PG		41 16	Y-BL BL-Y					
T0 R0	T0 R0	T0 R0	42 17	Y-O O-Y	S L O T 3	S L O T 7	S L O T 11	S L O T 15	Unit 4
CP MB	A PG		43 18	Y-G G-Y					
T1 R1	T1 R1	T1 R1	44 19	Y-BR BR-Y					
CP MB	A PG		45 20	Y-S S-Y					
T2 R2	T2 R2	T2 R2	46 21	V-BL BL-V					
CP MB	A PG		47 22	V-O O-V					
T3 R3	T3 R3	T3 R3	48 23	V-G G-V					
CP MB	A PG		49 24	V-BR BR-V					

Note: Use OVL 14 to select trunk termination impedance (600Ω or 900Ω). See X11 Input/Output Guide (553-3001-400) for information about OVL 14.

Table 24-17

NT8D14AA Universal Trunk connections for NT8D37 I/O panel connectors A,E,K,R

Lead designations			Pins	Pair Color	I/O Panel Connector				Unit Number
RAN mode	Paging mode	All other mode S			A	E	K	R	
T0 R0	T0 R0	T0 R0	26 1	W-BL BL-W	S L 0 T 0	S L 0 T 4	S L 0 T 8	S L 0 T 12	Unit 0
CP MB	A PG		27 2	W-O o-w					Unit 1
T1 R1	T1 R1	T1 R1	28 3	W-G G-W					Unit 2
CP MB	A PG		29 4	W-BR BR-W					Unit 3
T2 R2	T2 R2	T2 R2	30 5	w-s S-W					Unit 4
CP MB	A PG		31 6	R-BL BL-R					Unit 5
T3 R3	T3 R3	T3 R3	32 7	R-O O-R					Unit 6
CP MB	A PG		33 8	R-G G-R					Unit 7
T4 R4	T4 R4	T4 R4	34 9	R-BR BR-R					Unit 8
CP MB	A PG		35 10	R-S S-R					Unit 9
T5 R5	T5 R5	T5 R5	36 11	BK-BL BL-BK					Unit 10
CP MB	A PG		37 12	BK-S S-BK					Unit 11
T6 R6	T6 R6	T6 R6	38 13	BK-G G-BK					Unit 12
CP MB	A PG		39 14	BK-BR BR-BK					Unit 13
T7 R7	T7 R7	T7 R7	40 15	BK-S S-BK					Unit 14
CP MB	A PG		41 16	Y-BL BL-Y					Unit 15

Note: Use OVL 14 to select trunk termination impedance (600Ω or 900Ω). See X11 input/output Guide (5533001-400) for information about OVL 14.

Table 24-18
NT8D14AA Universal Trunk connections for NT8D37
I/O panel connectors B,F,L,S

Lead designations			Pins	Pair Color	I/O Panel Connector				Unit Number																
RAN mode	Paging mode	All other modes			B	F	L	S																	
T0 R0	T0 R0	T0 R0	26 1	W-BL BL-W	S L O T	S L O T	S L O T	S L O T	Unit 0																
CP MB	A PG		2 2	W-Ø Ø-W																					
T1 R1	T1 R1	T1 R1	28 3	W-G G-W					1	5	9	13	Unit 1												
CP MB	A PG		29 4	W-BR BR-W																					
T2 R2	T2 R2	T2 R2	30 5	W-S S-W									1	5	9	13	Unit 2								
CP MB	A PG		31 6	R-BL BL-R																					
T3 R3	T3 R3	T3 R3	3 7	R-O O-R													1	5	9	13	Unit 3				
CP MB	A PG		3 8	R-G G-R																					
T4 R4	T4 R4	T4 R4	34 9	R-BR BR-R																	1	5	9	13	Unit 4
CP MB	A PG		35 10	R-S S-R																					
T5 R5	T5 R5	T5 R5	36 11	BK-BL BL-BK	1	5	9	13																	Unit 5
CP MB	A PG		37 12	BK-S S-BK																					
T6 R6	T6 R6	T6 R6	38 13	BK-G G-BK					1	5	9	13													Unit 6
CP MB	A PG		39 14	BK-BR BR-BK																					
T7 R7	T7 R7	T7 R7	40 15	BK-S S-BK									1	5	9	13									Unit 7
CP MB	A PG		41 16	Y-BL BL-Y																					
T0 R0	T0 R0	T0 R0	42 17	Y-O O-Y													S L O T	S L O T	S L O T	S L O T					Unit 0
CP MB	A PG		43 18	Y-G G-Y																					
T1 R1	T1 R1	T1 R1	44 19	Y-BR BR-Y																	2	6	10	14	Unit 1
CP MB	A PG		45 20	Y-S S-Y																					
T2 R2	T2 R2	T2 R2	46 21	V-BL BL-V	2	6	10	14																	Unit 2
CP MB	A PG		47 22	V-O O-V																					
T3 R3	T3 R3	T3 R3	48 23	V-G G-V					2	6	10	14													Unit 3
CP MB	A PG		49 24	V-BR BR-V																					

Note: Use OVL 14 to select trunk termination impedance (600Ω or 900Ω). See X17 *input/output Guide* (553-3001-400) for information about OVL 14.

Table 24-19
NT8D14AA Universal Trunk connections for NT8D37
I/O panel connectors C,G,M,T

Lead designations			Pins	Pair Color	I/O Panel Connector				Unit Number
RAN mode	Paging mode	All other modes			C	G	M	T	
T0 R0	T0 R0	T0 R0	26 1	W-BL BL-W	S L O T	S L O T	S L O T	S L O T	Unit 4
CP MB	A PG		27 2	W-O O-W					
T1 R1	T1 R1	T1 R1	28 3	W-G G-W					
CP MB	A PG		29 4	W-BR BR-W					
T2 R2	T2 R2	T2 R2	30 5	W-S S-W					
CP MB	A PG		31 6	R-BL BL-R					
T3 R3	T3 R3	T3 R3	32 7	R-O O-R					
CP MB	A PG		33 8	R-G Q-R					
T4 R4	T4 R4	T4 R4	34 9	R-BR BR-R	S L O T	S L O T	S L O T	S L O T	Unit 0
CP MB	A PG		35 10	R-S S-R					
T5 R5	T5 R5	T5 R5	36 11	BK-SL BL-BK					
CP MB	A PG		37 12	BK-S S-BK					
T6 R6	T6 R6	T6 R6	36 13	BK-G G-SK					
CP MB	A PG		39 14	SK-SR BR-BK					
T7 R7	T7 R7	T7 R7	40 15	SK-S S-SK					
CP MB	A PG		41 16	Y-BL SL-Y					
T0 R0	T0 R0	T0 R0	42 17	Y-O O-Y	3	7	11	15	Unit 4
CP MB	A PG		43 18	Y-G G-Y					
T1 R1	T1 R1	T1 R1	44 19	Y-BR BR-Y					
CP MB	A PG		45 20	Y-S S-Y					
T2 R2	T2 R2	T2 R2	46 21	V-BL BL-V					
CP MB	A PG		47 22	V-O O-V					
T3 R3	T3 R3	T3 R3	48 23	V-G G-V					
CP MB	A PG		49 24	V-BR BR-V					

Note: Use OVL 14 to select trunk, termination impedance (600Ω or 900Ω). See X11 input/output G'd.9 (553 3001 400) for information about OVL 14.

Table 24-20

QPC449, 450 CO/FX/WATS/DID/2 way Dial Repeating/incoming Dial/Outgoing Automatic Loop Signalling/2W DX trunk connections

Unit Number	PE Cable Pair Color and Connection at Cross Connect Terminal			Connection	Termination	
	Slot in Shelf					
	1, 4, 7, 10, 13, 16	2, 5, 8, 11, 14	3, 6, 9, 12, 15			
Unit 0	W-BL	Y-O	R-BR	T0	900 Ω	To first Trunk 900 Ω Trunk
	BL-W	O-Y	BR-R	R0		
	W-O	Y-G	R-S	T0	600 Ω	600 Ω Trunk
	O-W	G-Y	S-R	R0		
	W-G	Y-BR	BK-BL	M	See Note	
	G-W	BR-Y	BL-BK	MM		
W-BR	Y-S	BK-O				
BR-W	S-Y	O-BK				
Unit 1	W-S	V-BL	BK-G	T1	900 Ω	To second Trunk 900 Ω Trunk
	S-W	BL-V	G-BK	R1		
	R-BL	V-O	BK-BR	T1	600 Ω	600 Ω Trunk
	BL-R	O-V	BR-BK	R1		
	R-O	V-G	BK-S	M	See Note	
	O-R	G-V	S-BK	MM		
R-G	V-BR	Y-BL				
G-R	BR-V	BL-Y				
Unit 2	R-BR	W-BL	Y-O	T2	900 Ω	To third Trunk 900 Ω Trunk
	BR-R	BL-W	O-Y	R2		
	R-S	W-O	Y-G	T2	600 Ω	600 Ω Trunk
	S-R	O-W	GR-Y	R2		
	BK-BL	W-G	Y-BR	M	See Note	
	BL-BK	G-W	BR-Y	MM		
BK-O	W-BR	Y-S				
O-BK	BR-W	S-Y				
Unit 3	BK-G	W-S	V-BL	T3	900 Ω	To fourth Trunk 900 Ω Trunk
	G-BK	S-W	BL-V	R3		
	BK-BR	R-BL	V-O	T3	600 Ω	600 Ω Trunk
	BR-BK	BL-R	O-V	R3		
	BK-S	R-O	V-G	M	See Note	
	S-BK	O-R	GR-V	MM		
Y-BL	R-G	V-BR				
BL-Y	G-R	BR-V				

Note: The M and MM leads are found on QPC219, QPC295, QPC330, QPC331 circuit packs and all circuit trunk circuit packs equipped with four units.

Table 24-21
Announcement Tone and Digit Switch and Music Trunk connections

Unit Number	PE Cable Pair Color and Connection at Cross Connect Terminal				Termination
	Slot in Shelf			Connection	
	1, 4, 7, 10, 13, 16	2, 5, 8, 11, 14	3, 6, 9, 12, 15		
Unit 0	W-BL BL-W W-O O-W	Y-O O-Y Y-G G-Y	R-BR BR-R R-S S-R	T R ● ●	To music or announcement source (Note)
Unit 1	W-G G-W W-BR BR-W	Y-BR BR-Y Y-S S-Y	BK-BL BL-BK BK-O O-BK	T R ● ●	To music or announcement source (Note)
Unit 2	W-S S-W R-BL BL-R	V-BL BL-V V-O O-V	BK-G G-BK BK-BR BR-BK	T R ● ●	To music or announcement source (Note)
Unit 3	R-O O-R R-G G-R	V-G G-V V-BR BR-V	BK-S S-BK Y-BL BL-Y	T R ● ●	To music or announcement source (Note)
Unit 4	R-BR BR-R R-S S-R	W-BL BL-W W-O O-W	Y-O O-Y Y-G GR-Y	T R ● ●	To music or announcement source (Note)
Unit 5	BK-BL BL-BK BK-O O-BK	W-G G-W W-BR BR-W	Y-BR BR-Y Y-S S-Y	T R ● ●	To music or announcement source (Note)
Unit 6	BK-G G-BK BK-BR BR-BK	W-S S-W R-BL BL-R	V-BL BL-V V-O O-V	T R ● ●	To music or announcement source (Note)
Unit 7	BK-S S-BK Y-BL BL-Y	R-O O-R R-G G-R	V-G GR-V V-BR BR-V	T R ● ●	To music or announcement source (Note)

Note: When a high **impedance** source (higher than 2 Ω) music or announcement source is used, the volume level of the source may have to be adjusted when altering the source. Low **impedance** sources (less than 2 Ω) are not usually affected by changes in the source.

Table 24-22
QPC71 2W E&M Signalling trunk connections

Unit Number	PE Cable Pair Color and Connection at Cross Connect Terminal			Connection	Termination	
	Slot in Shelf					
	1, 4, 7, 10, 13, 16	2, 5, 8, 11, 14	3, 6, 9, 12, 15			
Unit 0	W-BL	Y-O	R-BR	T0	900 Ω	To first Trunk 900 Ω Trunk
	BL-W	O-Y	BR-R	R0		
	W-O	Y-G	R-S	T0	600 Ω	600 Ω Trunk
	O-W	G-Y	S-R	R0		
	W-G	Y-BR	BK-BL	A1.0	E&M or DX (4W) Signalling	
	G-W	BR-Y	BL-BK	B1E.0		
W-BR	Y-S	BK-O	M0			
BR-W	S-Y	O-BK				
Unit 1	W-S	V-BL	BK-G	T1	900 Ω	To second Trunk 900 Ω Trunk
	S-W	BL-V	G-BK	R1		
	R-BL	V-O	BK-BR	T1	600 Ω	600 Ω Trunk
	BL-R	O-V	BR-BK	R1		
	R-O	V-G	BK-S	A1.1	E&M or DX (4W) Signalling	
	O-R	G-V	S-BK	B1E.1		
R-G	V-BR	Y-BL	M1			
G-R	BR-V	BL-Y				

Table 24-23
QPC71 Paging trunk connections

Unit Number	PE Cable Pair Color and Connection at Cross Connect Terminal			Connection	Termination	
	Card Number					
	1, 4, 7, 10, 13, 16	2, 5, 8, 11, 14	3, 6, 9, 12, 15			
Unit 0	W-BL	Y-O	R-BR	T0.9	900 Ω	First Trunk 900 Ω Amplifier
	BL-W	O-Y	BR-R	R0.9		
	W-O	Y-G	R-S	T0.6	600 Ω	600 Ω Amplifier
	O-W	G-Y	S-R	R0.6		
	W-G	Y-BR	BK-BL	A1.0	●	Control Connection
	G-W	BR-Y	BL-BK			
W-BR	Y-S	BK-O	PG0	●		
BR-W	S-Y	O-BK				
Unit 1	W-S	V-BL	BK-G	T1	900 Ω	Second Trunk 900 Ω Amplifier
	S-W	BL-V	G-BK	R1		
	R-BL	V-O	BK-BR	T1	600 Ω	600 Ω Amplifier
	BL-R	O-V	BR-BK	R1		
	R-O	V-G	BK-S	A1.1	●	Control Connection
	O-R	G-V	S-BK			
R-G	V-BR	Y-BL	PG0	●		
G-R	BR-V	BL-Y				

Table 24-24
Release Link Trunk for Centralized Attendant Service connections

Unit Number	PE Cable Pair Color and Connection at Cross Connect Terminal			Connection	Termination	
	Slot in Shelf					
	1, 4, 7, 10, 13, 16	2, 5, 8, 11, 14	3, 6, 9, 12, 15			
Unit 0	W-BL	Y-O	R-BR	T0	900 Ω	First Trunk To 900 Ω Termination
	BL-W	O-Y	BR-R	R0		
	W-O	Y-G	R-S			or
	O-W	G-Y	S-R			
	W-G	Y-BR	BK-BL	T0	600 Ω	600 Ω Termination at Far End
	G-W	BR-Y	BL-BK	R0		
	W-BR	Y-S	BK-O			
	BR-W	S-Y	O-BK			
Unit 1	W-S	V-BL	BK-G	T1	900 Ω	Second Trunk To 900 Ω Termination
	S-W	BL-V	G-BK	R1		
	R-BL	V-O	BK-BR			or
	BL-R	O-V	BR-BK			
	R-O	V-G	BK-S	T1	600 Ω	600 Ω Termination at Far End
	O-R	G-V	S-BK	R1		
	R-G	V-BR	Y-BL			
	G-R	BR-V	BL-Y			

Table 24-25
GPC73, 239 Recorded Telephone Dictation Applique Trunk connections

Unit Number	PE Cable Pair Color and Connection at Cross Connect Terminal				Termination
	Card Number			Connection	
	1, 4, 7, 10, 13, 16	2, 5, 8, 11, 14	3, 6, 9, 12, 15		
Unit 0	W-BL	Y-O	R-BR	S0	First Trunk Signalling
	BL-W	O-Y	BR-R		
	W-O	Y-G	R-S	T0	Voice
	O-W	G-Y	S-R	R0	
	W-G	Y-BR	BK-BL	DTA0	Dial Tone
	G-W	BR-Y	BL-BK	DTB0	
	W-BR	Y-S	BK-O	ARA0	Audible RingbackTone
	BR-W	S-Y	O-BK	ARB0	
Unit 1	W-S	V-BL	BK-G	S1	Second Trunk Signalling
	S-W	BL-V	G-BK		
	R-BL	V-O	BK-BR	T1	Voice
	BL-R	O-V	BR-BK	R1	
	R-O	V-G	BK-S	DTA1	Dial Tone
	O-R	G-V	S-BK	DTB1	
	R-G	V-BR	Y-BL	ARA1	Audible RingbackTone
	G-R	BR-V	BL-Y	ARB1	

Table 24-26
QPC74 Recorded Announcement Trunk connections

Unit Number	PE Cable Pair Color and Connection at Cross Connect Terminal				Termination
	Slot in Shelf			Connection	
	1, 4, 7, 10, 13, 16	2, 5, 8, 11, 14	3, 6, 9, 12, 15		
Unit 0	W-BL BL-W W-O O-W	Y-O O-Y Y-G G-Y	R-BR BR-R R-S S-R	T0 R0 CP0 CS0 (or SMB0)	To Recorded Announcement Machine -- See owners manual
Unit 1	W-G G-W W-BR BR-W	Y-BR BR-Y Y-S S-Y	BK-BL BL-BK BK-O O-BK	T1 R1 CP1 CS1 (or SMB1)	To another Recorded Announcement Machine or bridged to same one
Unit 2	W-S S-W R-BL BL-R	V-BL BL-V V-O O-V	BK-G G-BK BK-BR BR-BK	T2 R2 CP2 CS2 (or SMB2)	
Unit 3	R-O O-R R-G G-R	V-G G-V V-BR BR-V	BK-S S-BK Y-BL BL-Y	T3 R3 CP3 CS3 (or SMB3)	

Table 24-27
QPC237 4W E&M/DX Trunk connections

Unit Number	PE Cable Pair Color and Connection at Cross Connect Terminal						Termination
	Slot in Shelf			Connection			
	1, 4, 7, 10, 13, 16	2, 5, 8, 11, 14	3, 6, 9, 12, 15	Type 1 E&M	Type 2 E&M	DX	
Unit 0	-W-BL	-Y-O	-R-BR	-TO	-TO	-TO	To first Trunk
	-BL-W	-O-Y	-BR-R	-R0	-R0	-R0	Transmit pair
	-W-O	-Y-G	-R-S	-T1	-T1	-T1	Receive pair
	-O-W	-G-Y	-S-R	-R1	-R1	-R1	
	-W-G	-Y-BR	-BK-BL	-ESCG	-EB		Signaling pair
	-G-W	-BR-Y	-BL-BK	-E	-E A		Signaling pair
Unit 1	-W-BR	-Y-S	-BK-O	-ESC	-MB		Signaling pair
	-BR-W	-S-Y	-O-BK	-MM	-MA		
	-W-S	-Y-BL	-BK-G	-TO	-TO	-TO	To second Trunk
	-S-W	-BL-V	-G-BK	-R0	-R0	-R0	Transmit pair
	-R-BL	-V-O	-BK-BR	-T1	-T1	-T1	Receive pair
	-BL-R	-O-V	-BR-BK	-R1	-R1	-R1	
-R-O	-V-G	-BK-S	-ESCG	-EB		Signaling pair	
-O-R	-G-V	-S-BK	-E	-E A		Signaling pair	
-R-G	-V-BR	-Y-BL	-ESC	-MB		Signaling pair	
-G-R	-BR-V	-BL-Y	-M	-MA			

Procedure 25: Connecting trunks and telephones to the PFTU

General information

Use this procedure to connect trunks and telephones to an NT8D39-type power fail transfer unit (PFTU).

Each PFTU can transfer up to eight trunks (PFT 1 through PFT 8). The PFTU and its associated connecting blocks should have been installed and connections to related attendant consoles should have been made (as detailed in **Procedure 17: Installing a Power Failure Transfer Unit**) before performing the steps in this procedure.

The “ground start” feature on 500/2500-type telephones connected to trunks requiring a ground start condition is not required. This function is performed automatically by the PFTU. Rotary dials (dial pulse) are required on telephones assigned to trunks which are not equipped to recognize tone pulses (touch tone).

Table 25-1 shows the cable termination sequence and assignments at the cross connect terminal for trunks and telephones. If the connections are not designated on the connecting blocks, mark the blocks as shown in the table or install the appropriate designation strips. Refer to this table while performing the steps in the procedure.

Connecting the trunks and telephones

- 1 Locate the PFTU connecting blocks at the cross connect terminal.
- 2 Repeat for each trunk assigned to the PFTU:

Connect the tip and ring of the 500/2500 line card to the first pair of the assigned PFTU. See Table 25-1.

Connect the tip and ring of the 500/2500-type telephone to the second pair of the assigned PFTU. See Table 25-1.

Connect the tip and ring of the CO trunk to the fourth pair of the assigned PFTU. See Table 25-1.

Connect the tip and ring of the trunk card to the third pair of the assigned PFTU. See Table 25-1.

Table 25-1
PFTU cross-connections

PAIR	PIN NUMBER	COLOR	PFTU CABLE 1	PFT	PFTU CABLE 2	PFT
T0	26	W-BL	To line card	1	To line card	5
R0	1	BL-W				
T1	27	w-o	To telephone set	1	To telephone set	5
R1	2	o-w				
T2	26	W-G	To CO trunk	1	To CO trunk	5
R2	3	G-W				
T3	29	W-B	To trunk card	1	To trunk card	5
R3	4	B-W				
T4	30	w-s	To line card	2	To line card	6
R4	5	s-w				
T5	31	R-BL	To telephone set	2	To telephone set	6
R5	6	BL-R				
T6	32	R-O	To CO trunk	2	To CO trunk	6
R6	7	O-R				
T7	33	R-G	To trunk card	2	To trunk card	6
R7	a	G-R				
T8	34	R-BR	To line card	3	To line card	7
R8	9	BR-R				
T9	35	R-S	To telephone set	3	To telephone set	7
R9	10	S-R				
T10	36	BK-BL	To CO trunk	3	To CO trunk	7
R10	11	BL-BK				
T11	37	BK-O	To trunk card	3	To trunk card	7
R11	12	O-BK				
T12	38	BK-G	To line card	4	To line card	a
R12	13	G-BK				
T13	39	BK-BR	To telephone set	4	To telephone set	a
R13	14	BR-BK				
T14	40	BK-S	To CO trunk	4	To CO trunk	a
R14	15	S-BK				
T15	41	Y-BL	To trunk card	4	To trunk card	a
R15	16	BL-Y				

Procedure 26: System power-up and initial loading

General information

Use this procedure to perform power-up and initial loading (SYSLOAD) of an SL-1 system. An **NT8D22** System Monitor must be installed in each equipment column in system options **21, 51, 61** and 71 prior to executing a SYSLOAD

Power-up and SYSLOAD procedure

- 1 Check the diskettes supplied with the system to verify that they are the correct software version and issue.
- 2 Ensure that the correct Data Cartridge is installed on the QPC584 MSI or QPC742 FDI circuit pack.
 - Disconnect the cables from the faceplate of the **MSI** or FDI circuit pack.
 - Remove the **MSI** or FDI circuit pack from its position in the shelf.
 - Locate the data cartridge connected to connector J2 on the component side of the circuit pack.
 - Make sure that the ID number and software version indicated on the data cartridges matches that of the diskettes supplied with the system.
- 3 Make sure the option switches on the **MSI** or FDI circuit packs are set for floppy disk operation.

Switches 1 and 5 should be set to **ON**. The remaining switches should be set to **OFF**.
- 4 Insert the **MSI** or FDI circuit packs in their assigned positions.

CAUTION

The **NT8D68AA** Floppy Disk Unit is powered from the **NT8D77** cable which connects it to the **QPC742** Floppy Disk Interface circuit pack. To prevent an electrical short which might disable the UEM, do not **insert** the **QPC742** circuit pack into its assigned position until **after** you have connected the **NT8D77** cable.

- Reconnect the cables to the faceplate connectors.
- Set the **ENB/DIS** switch on each circuit pack to **ENB**.

5 Power up all AC-powered equipment columns.

- Test AC power source to verify that proper voltage is **present**.
- Set the MAIN circuit breaker located at the **rear** of each pedestal to **OFF**.
- Set the circuit breakers located on the Module Power Distribution Unit (MPDU) in each UEM to ON.
- Set the circuit breaker for the blowers located in the front of each pedestal to ON.
- Connect the power cords from each pedestal to the AC power supply outlet.
- Set the MAIN circuit breaker at the rear of each pedestal to ON.

6 Power up all DC-powered equipment columns.

- Test dc power source to verify that proper voltage is present.
- Set the main circuit breaker on each rectifier to **OFF**.
- Set all the circuit breakers located at the rear of each pedestal to **OFF**.
- If a QCA13 power cabinet, a **QBL12** battery distribution box or a **QBL15** power distribution box is provided, make sure that the fuse for each column is inserted in the fuse panel.
- Make sure that the AC line cord to each rectifier is connected to the AC power supply.

- Set all power supply switches and blower switches to ON.
- Set the circuit breaker on each rectifier to ON.
- Set the following circuit breakers at the rear of each pedestal to ON, starting from left to right:
 - The circuit breaker for the blower (first breaker on the left)
 - The second circuit breaker (for UEM 0)
 - The third circuit breaker (if UEM 1 is equipped)
 - The fourth circuit breaker (if UEM 2 is equipped)
 - The fifth circuit breaker (if UEM 3 is equipped).
- The blowers in each pedestal should be operating.

7 Load the system.

- Insert the diskettes in their respective drives (A and B).
- On system options 5 1, 61, and 7 1, **simultaneously** press the reload (**RLD**) buttons on each QPC581 Changeover and Memory Arbitrator (CMA) circuit pack equipped. A system reload (SYSLOAD) will occur. --
- On system option 21, set the baud rate for the SDI port on the QPC687 CPU Card to match the baud rate of your system terminal, and press the QPC687 reload (**RLD**) button. A system reload (SYSLOAD) will occur.
- The LED on the front of one of the disk drives should light indicating that the data is being copied from the disk into the system memory. The LEDs on the memory packs flash as memory checks take place. The hexadecimal display on the faceplate of the Mass Storage Interface (MSI) circuit pack indicates the status of the active disk drive.
- The system terminal will display DONE when loading is complete, and the system automatically invokes an initialize. When initialization is complete, the system begins the midnight diagnostic routines.

Refer to *the XII input/output guide (553-3001-400)* if

- The system terminal displays any **INI** codes other than INIOOO.
- Any Common Equipment circuit pack **LEDs** are lit.
- The maintenance display shows other than 00 or blank.

Note: The remaining steps in this procedure apply only to systems equipped with an **NT8D69AA** Multi Disk Unit (MDU).

- 8 Set the **ENB/DIS** switch on the faceplate of both **MSI** circuit packs to **DIS**.
 - Disconnect the cables from the faceplate on each **MSI** circuit pack.
 - Remove the **MSI** circuit packs from their position in the shelf.
 - Set option switches **1, 4,** and **5** to **ON** for hard disk operation. The remaining switches should be set to **OFF**.
- 9 Insert the **MSI** circuit packs in their assigned positions.
 - Reconnect the cables to the faceplate connectors.
 - Set the **ENB/DIS** switch on each circuit pack to **ENB**.
- 10 Load Overlay 43 (**LD 43**) and enter command **RES** to transfer the contents of the floppy disks in drives **A** and **B** to the hard disk. Refer to the *XI 1 input/output guide (553-3001-400)* for instructions on the use of overlay programs.

Procedure 27: Testing UEM power supplies

General information

Use this procedure to test the following power supplies to ensure that the System Monitor detects and reports abnormal conditions affecting them. These tests should be performed on the following power supplies whenever a system or a UEM is containing them is installed:

NT8D29AA Common Equipment Power Supply AC

NT6D41AA Common Equipment Power Supply DC

NT7D14AA Common/Peripheral Equipment Power Supply AC

NT7D04AA Common/Peripheral Equipment Power Supply DC

NT8D06AA Peripheral Equipment Power Supply AC

NT6D40AA Peripheral Equipment Power Supply DC

NT8D21AA Ring Generator AC

NT7D03AA Ring Generator DC

Performing these tests on a single CPU system may cause **SYSLOADs** to occur. The **SYSLOADs** should be disregarded while performing the tests. Performing these tests on a dual CPU system may cause the system to initialize. **INI** messages should also be disregarded for the duration of the tests. See XII *input/output guide* (553-3001-400) for information regarding error messages.

Test procedure

- 1 Verify that the **LEDs** on all power supplies are lit and that the red LED at the top of the UEM column is OFF.
- 2 Set the circuit breaker or power switch for the power supply to OFF.
 - The green LED on the front of the power supply should go out.
 - The red LED at the top front of the column should go on.
 - The system terminal should display a BSD090 message and a PWR0002 message.

- 3 Set the circuit breaker or power switch for the power supply to ON.
 - The green LED on the front of the power supply should go on.
 - The red LED at the top front of the column should go out.
 - The system terminal should display a PWROOOO message.

- 4 Set the circuit breaker or power switch for the power supply to OFF. Unseat the power supply. Set the circuit breaker or power switch to ON.
 - The green LED on the front of the power supply should go off.
 - The red LED at the top front of the column should go on.
 - The system terminal should display a BSD090 message and a PWR0003 message.

- 5 Set the circuit breaker or power switch for the power supply to ON.. Insert the power supply in its assigned position. Set the circuit breaker or power switch to ON.
 - The green LED on the front of the power supply should go on.
 - The red LED at the top front of the column should go out.
 - The system terminal should display a PWROOOO message.

- 6 Repeat steps 1-4 for each power supply equipped.



--

y

Procedure 28: Blower unit and thermal sensor tests

General information

Use **this** procedure to test the **NT8D52** blower unit to ensure that the system monitor detects and reports abnormal conditions affecting it. This test should be performed on the blower unit when an equipment column is initially installed.

Acceptance tests

- 1 Set the blower unit circuit breaker or power switch to OFF.
 - The red LED at the top front of the column should go on.
 - The system terminal should display a BSD090 message and a PWR0006 message.

- 2 Set the blower unit circuit breaker or power switch to ON.
 - The red LED at the top front of the column should go out.
 - The system terminal should display a PWR0046 message.

- 3 Use a screwdriver to loosen the retaining screws at **the** front of the blower unit and pull the unit out until it is disconnected from the pedestal. See Figure 28-1.
 - The **red** LED at the top front of the column should go on.
 - The system terminal should display a BSD090 message and a PWR0006 message.

- 4 Reinstall the blower unit and tighten its retaining screws.
 - The **red** LED at the front of the column should go out.
 - The system terminal should display a PWR0046 message.

- 5 Heat one of the two thermal sensors under the top cap of the column with a hand held hair dryer or other similar heat source.
 - The red LED at the top front of the column should go out,
 - 30 seconds after the thermal sensor detects 70° C (158° F), the main circuit breaker located at the rear of the pedestal should trip. The system terminal should display PWR0004, PWR0006, and PWR0007 messages.

- 6 Allow the sensor to cool, then reset the main circuit breaker at the rear of the cabinet. If a SYSLOAD occurs, allow it to complete.
 - The red LED at the top front of the column should go out.
 - The system terminal should display PWR0044, PWR0046, and PWR0047 messages.

- 7 Repeat steps 5 and 6 for the other thermal sensor.

Figure 28-1
Blower unit removal

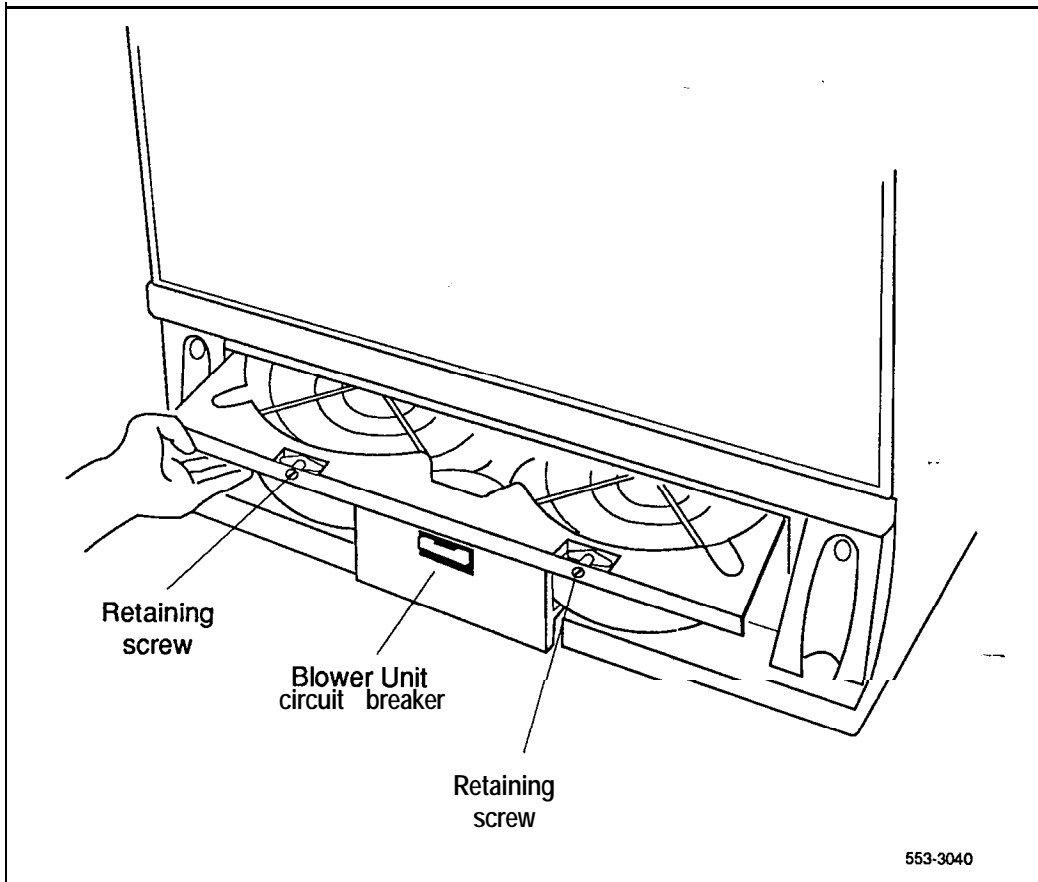



Procedure 29: System loading (SYSLOAD) tests

General information

Use this procedure to test the SYSLOAD function of an SL-1 system.

See XII input/output guide (553-3001-400) for an interpretation of messages and display codes generated by the system during the SYSLOAD procedure.

SYSLOAD tests

- 1 On system option 5 1, 6 1, and 7 1, simultaneously press the reload (RLD) buttons on both QPC581 CMA circuit packs. A system reload (SYSLOAD) will occur.

On system option 21, press the reload (RLD) button on the QPC687 CPU Card. A system reload (SYSLOAD) will occur.

- 2 Observe the following actions:
 - The red LED at the top of the column should go on.
 - The red LED on the front of all the PFTUs should go on. —
 - The “major” alarm indication should be displayed on all attendant consoles.
 - The LED on the front of one of the disk drives should go on indicating that the data is being copied from the disk into the system memory.
 - The display on the faceplate of the MSI or FDI circuit pack will indicate the status of the mass storage unit.
 - On system options 5 1, 61 and 7 1, the LEDs on the memory packs should flash as memory checks take place.
 - On system options 5 1, 61 and 7 1, various codes will be displayed on the faceplate of the QPC580 CPU Interface (IF) circuit pack.
 - On system option 21, various codes will be displayed on the faceplate of the NT8D19AA Memory/Signalling Card.

- 3 The system terminal will display `DONE` when loading is complete. The system then automatically invokes an initialize. The following should be observed upon completion of the initialization:
 - The red LED at the top of the column should go out.
 - The red LED on the front of all the **PFTUs** should go out.
 - The green LED on the front of all the **PFTUs** should go on.
 - The “major” alarm indication should disappear from all attendant consoles.

- 4 Allow the system to complete midnight routine programs. Press the carriage return key on the terminal to monitor progress of the routines until **OVL111** BKGD response is received.

Procedure 30: Power Fail Transfer Unit (PFTU) test

General information

Use this procedure to test an **NT8D39-type** Power Fail Transfer Unit (**PFTU**) to ensure that the unit operates correctly and that the System Monitor reports abnormal conditions affecting it.

Acceptance tests

- 1 Set the line transfer switch on the **PFTU** to ON.
 - The red LED at the top front of the column served by the **PFTU** should go on.
 - Attendant consoles associated with the **PFTU** should display a “major” alarm.
 - The system terminal should display a **BSD090** message and a **PWR0016** message.

- 2 Set the line transfer switch on the attendant console associated with the **PFTU** to ON.
 - The red LED at the top front of the column served by the **PFTU** should go on.
 - Attendant consoles associated with the **PFTU** should display a “major” alarm.
 - The system terminal should display a **BSD090** message and a **PWR0016** message.

- 3 Set the line transfer switch on the attendant console associated with the **PFTU** to OFF.
 - The red LED at the top front of the column should go out.
 - The “major” alarm condition displayed on attendant consoles associated with the **PFTU** should disappear.
 - The system terminal should display a **PWR0056** message.

- 4 Repeat steps 2 and 3 for each attendant console associated with the **PFTU**.
- 5 Set the line transfer switch on the PFTU to ON and test **the telephones** and trunks that are connected to the PFTU.
 - Place an outgoing call from each telephone associated with the PFTU. Each telephone should be connected directly to a trunk.
 - Place an incoming call on each trunk associated with the **PFTU**. Each trunk should be connected directly to a telephone.
- 6 Set the line transfer switch on the **PFTU** to OFF and test the telephones and trunks that are connected to the **PFTU**. The **telephones** and trunks associated with the PFTU should return to normal operation.

Procedure 31: Terminal test

General information

Use this procedure to test terminal devices attached to an SL-1 system,

Test procedure

- 1 Log into the system:
LOG1 (password)
- 2 Load Overlay 37:
LD37
- 3 Test the terminal:
TTYN

N is the number assigned to the system terminal device.

- 4 Step through the keys on the keyboard one at a time. All keyboard input is echoed until **END** is entered.
- 5 **Exit Overlay 37:**

31-2 Terminal test

Procedure 32: Disk drive test

General information

Use this procedure to test an **NT8D68AA** Floppy Disk Unit (**FDU**) or an **NT8D69AA** Multi Disk Unit (**MDU**).

Test procedure

- 1 Log into the **system**:
LOCI (password)
- 2 Load Overlay 37:
LD 37
- 3 Ensure that the disk drive unit to be tested is not disabled: ..
STAT **MSI**
- 4 If the disk drive unit to be tested is disabled, enable it:
ENL **MSI 0**
- 5 Test the desired disk drive **unit**:
MSI 0 ..
- 6 If system response is other than OK, refer to XII **input/output guide** (553-3001-400) to analyze message.
- 7 **Exit Overlay 37**:

Note: Perform steps 8 through 10 on dual CPU systems only:
- 8 Load Overlay 35:
LD 35
- 9 Switch **CPUs**:
SCPU
- 10 Repeat steps 1 through 7 above.

32-2 Disk drive test



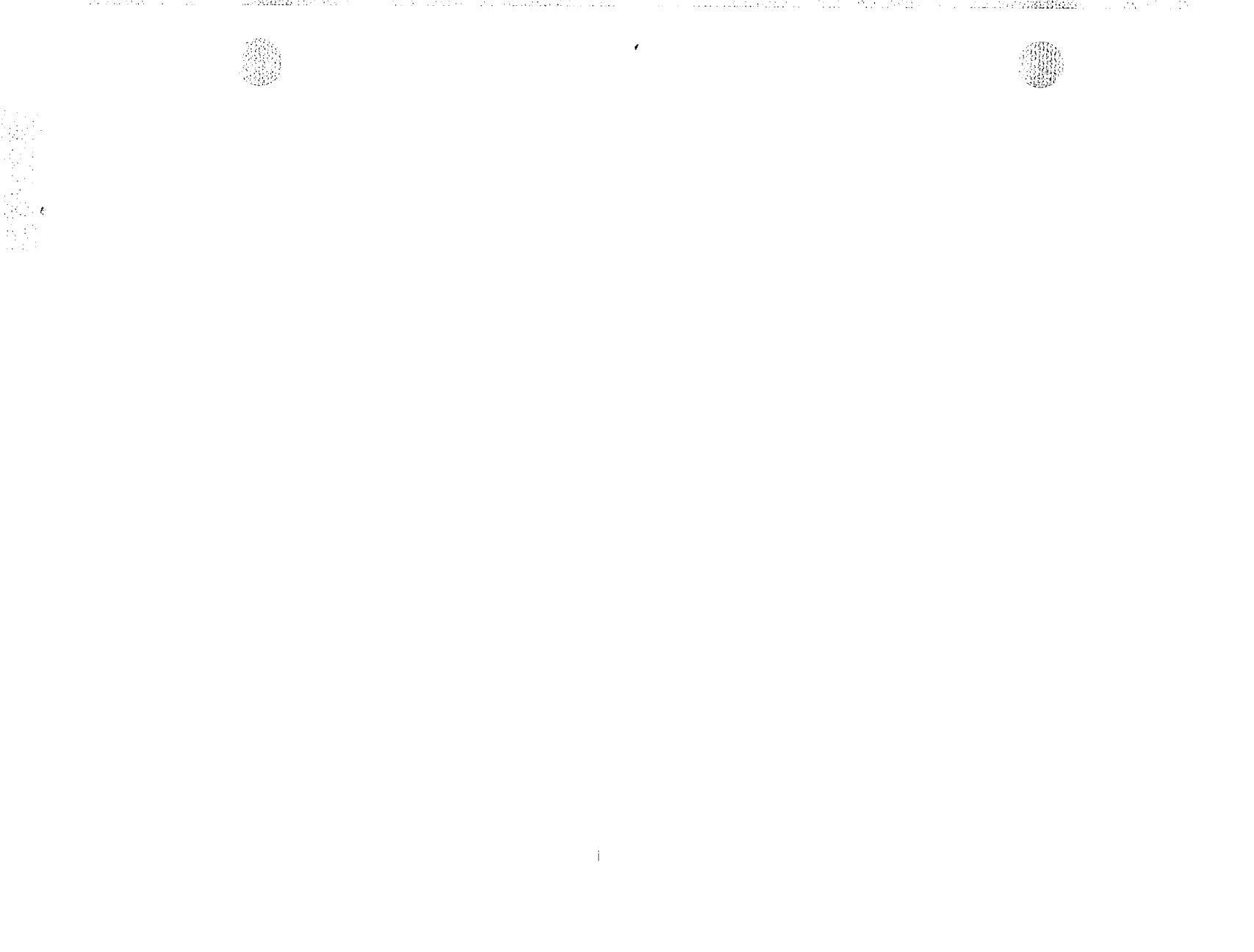

SL-1

System options 21, 51, 61, 71

System installation procedures

© 1990 Northern Telecom

All rights reserved.

Information subject to change without notice.

Release 2.0

Standard

February 28, 1990

Printed in U.S.A.



553-3001-211

SL-1

System options 21, 51, 61, 71

Circuit pack installation and testing
Standard

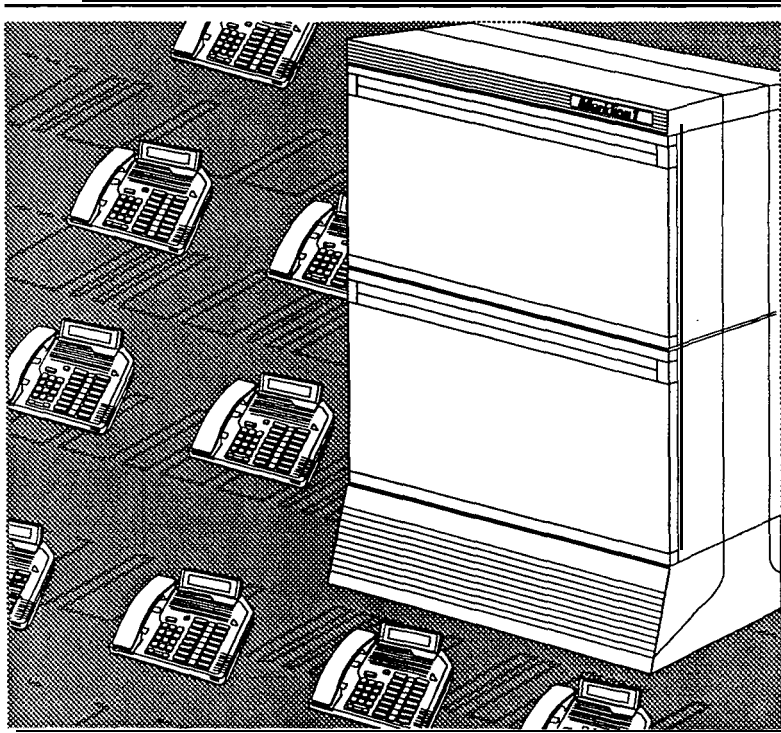

nt northern
telecom

Meridian 1
Communication Systems



SL-1

System options 21, 51, 61, 71

Circuit pack installation and testing

Publication number: 553-3001-211

Document Status: Standard

Document release: 1 .0

Date: January **29, 1990**

© 1984 Northern **Telecom**

All rights reserved.

ii

Revision history

January 29, 1990

Standard, release 1.0

About this document

References

See the SL-I planning & engineering guide for

- **Master index** (553-3001-000)
- **System overview** (553-3001-100)
- **Installation planning** (553-3001-120)
- **System engineering** (553-3001-151)
- **Power engineering** (553-3001-152)
- **Sparesplanning** (553-3001-153)
- **Equipment identification and ordering** (553-3001-154)

See the list of line and trunk circuit descriptions in the Master index (553-3001-000) for specific references to lines and trunks.

See the SL-1 installation and maintenance guide for

- **System installation procedures** (553-3001-210)
- **Circuitpack installation and testing** (553-3001-211)
- **Installation procedures for telephone sets and attendant consoles** (553-3001-215)
- **Extended systems installation** (553-3001-250)
- **Disk drive upgrade procedures** (553-3001-251)
- **General maintenance information** (553-3001-500)
- **Fault clearing** (553-3001-510)

— **Hardware replacement** (553-3001-520)

See the **SL-1 X11 software guide** for an overview of software architecture, procedures for software installation and management, and a **detailed** description of all X11 features and services. **This** information is contained in two documents:

— **X11 software management** (553-3001-300)

— **X11 features and services** (553-3001-305)

See the **SL-1 X11 input/output guide** (553-3001-400) for a description of all administration programs, maintenance programs, and system messages.



Contents

Circuit pack installation	I-1
UEM circuit pack installation locations	I-2
Installing a circuit pack	1-10
Conference Circuit Test	1-13
Digitone Receiver Circuit Test	1-15
Line Circuit Test	I-16
Multifrequency Compelled Signalling Circuit Test	1-17
Multifrequency Sender Circuit Test	1-18
Tone and Digit Switch (TDS) Test	I-19
Network Circuit Test	1-21
Trunk Circuit Test	1-22
<hr/>	
Option switch settings	2-1
Chapter contents	2-1
<hr/>	
Circuit pack application examples	3-1
SL-1 system option 21 and ST switch settings	3-1
SL-1 system option 51, 61 and NT switch settings	3-5
SL-1 system option 71 and XT switch settings	3-8

Circuit pack installation

General information

The SL-1 system makes extensive use of printed circuit boards for circuit packs, shelf backplanes, and various other types of apparatus. Many of these circuit boards require the setting of switches, plugs, or jumpers on the **board** itself to determine the function the board will perform when installed in the system.

This document lists the setting of switches, plugs, or jumpers for all circuit packs used by SL-1 system **except:**

- SL-1 telephone sets
- attendant consoles
- add-on modules

Note: Switch settings for these items can be found in **the** document that describes the item. Consult the **Master index (553-3001-000)** for a complete list.

This document applies to all SL-1 systems, so it may contain information on circuit packs that are not applicable to a particular SL-1 system.

UEM circuit pack installation locations

Figures 1-1 through 1-7 show where circuit packs are installed in the following Universal Equipment Modules (UEMs):

- NT8D34 CPU Module
- NT6D39 CPU/Network Module
- NT8D1 1 **Common/Peripheral** Equipment Module
- NT8D35 Network Module
- NT8D13 Peripheral Equipment Module front panel
- NT8D37 Intelligent Peripheral Equipment Module
- NT8D47 Remote Peripheral Equipment Module

Figure 1-1
NT8D34 CPU Module

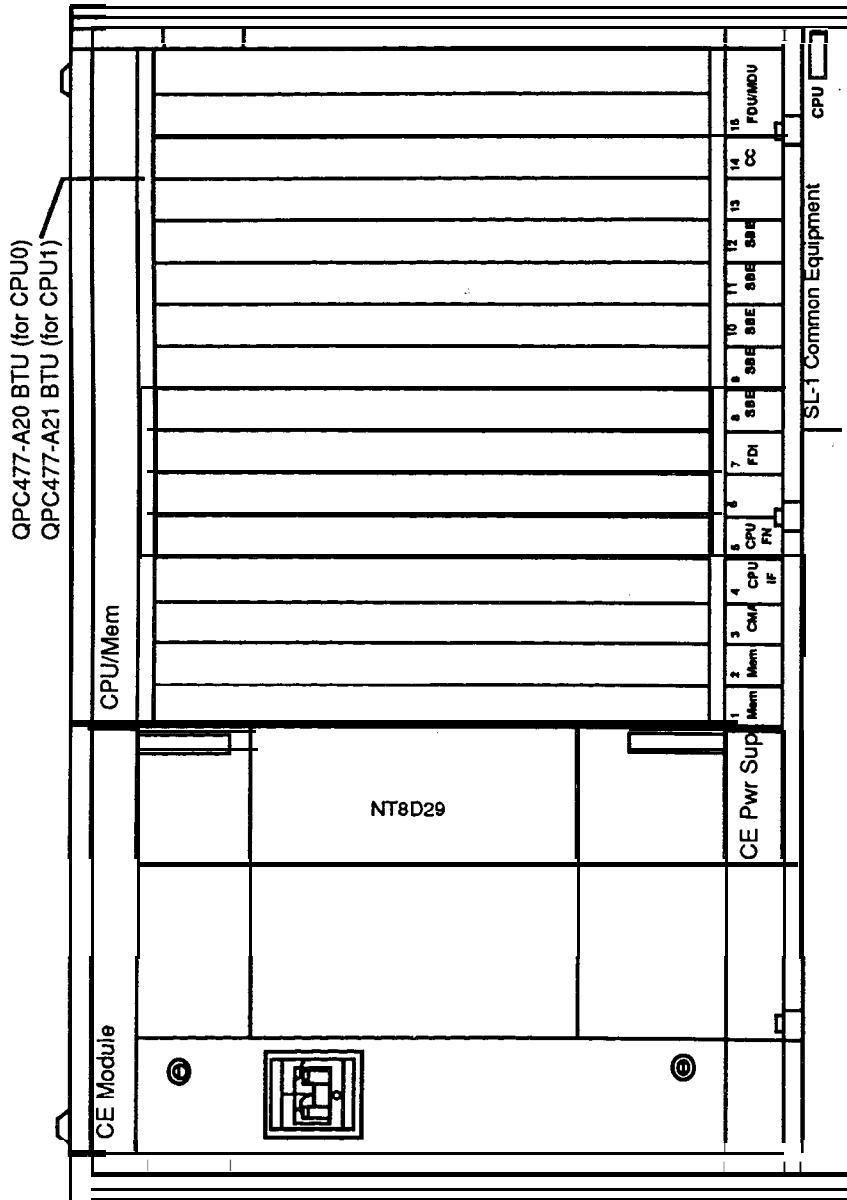

Figure 1-2
NT6D39 CPU/Network Module

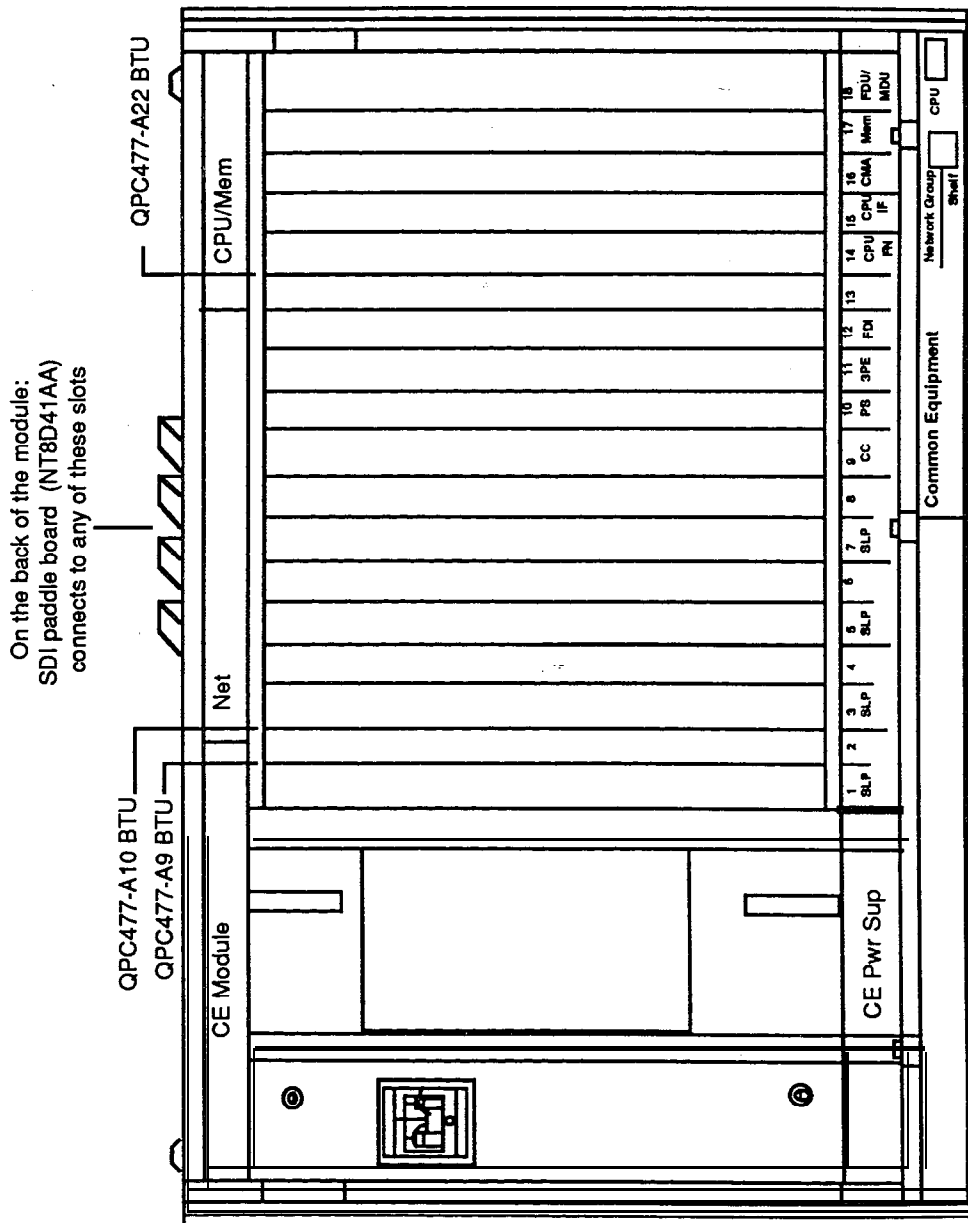

Figure I-3
 NT8D11 Common/Peripheral Equipment Module

On the back of the module:
 SDI paddle board (NT8D41AA) connects to any of these slots.
 System Monitor (NT7D15AA) connects to any of these slots (for system option 21A only).

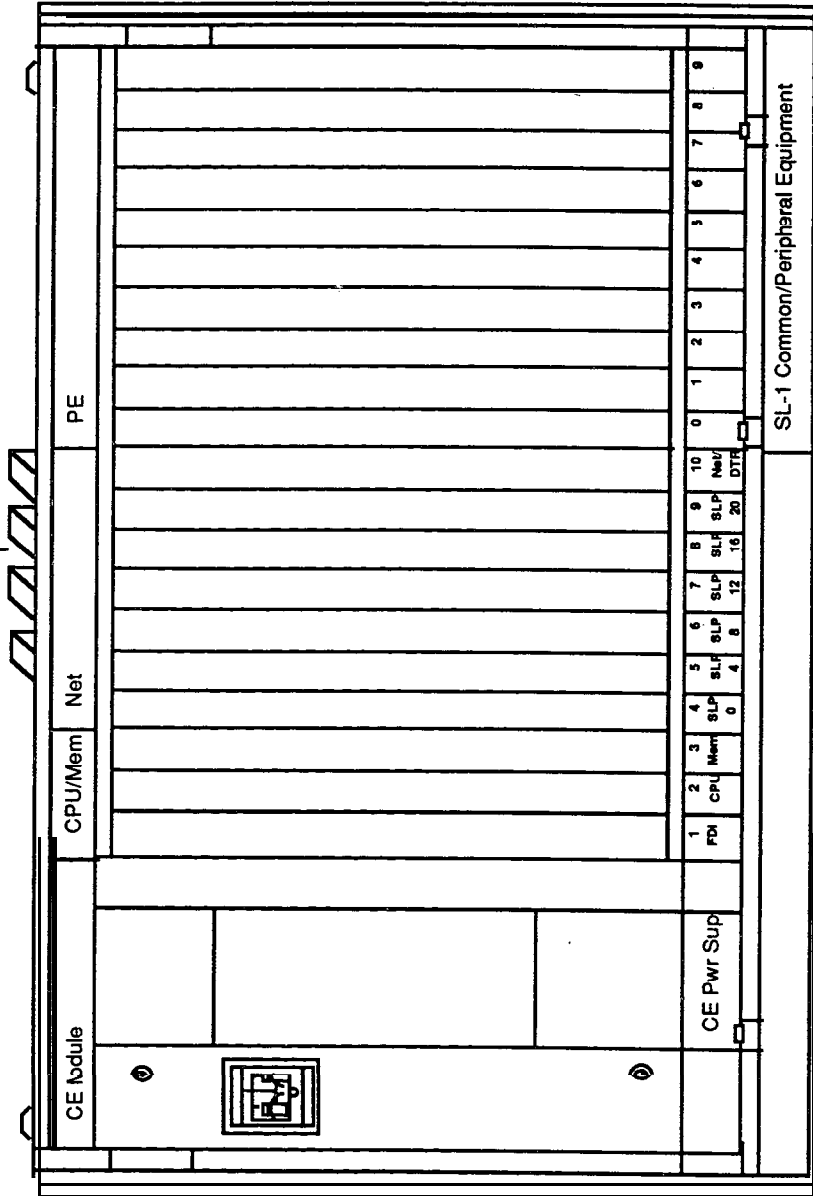

Figure 1-4
NT8D35 Network Module

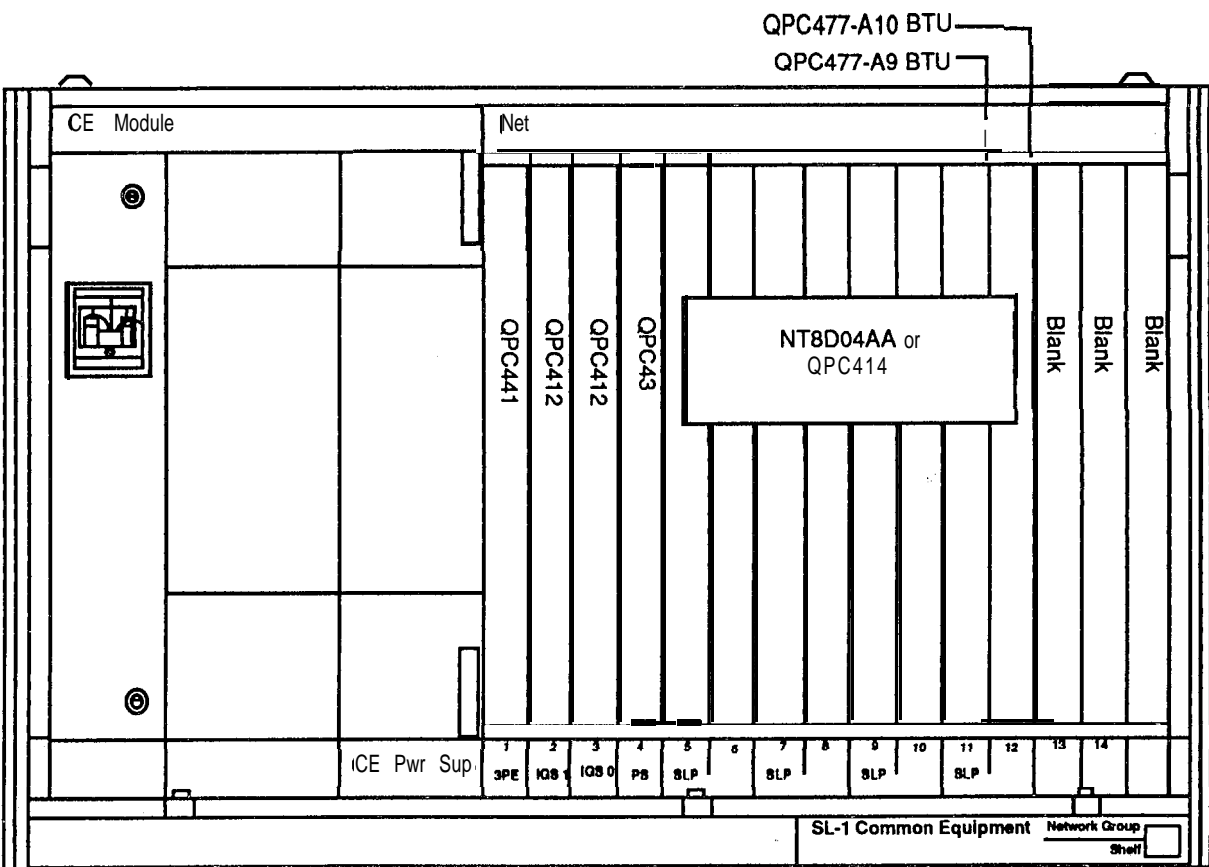

Figure 1-5
NT8D13 Peripheral Equipment Module front panel

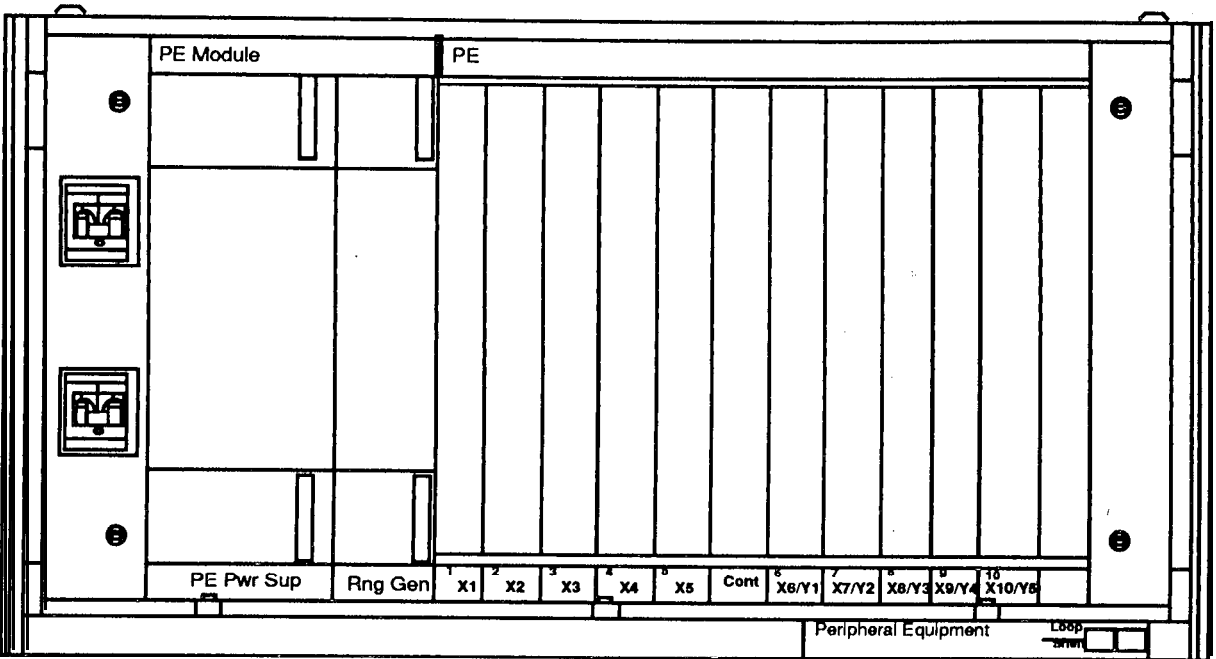

Figure 1-6
NT8D37 Intelligent Peripheral Equipment Module

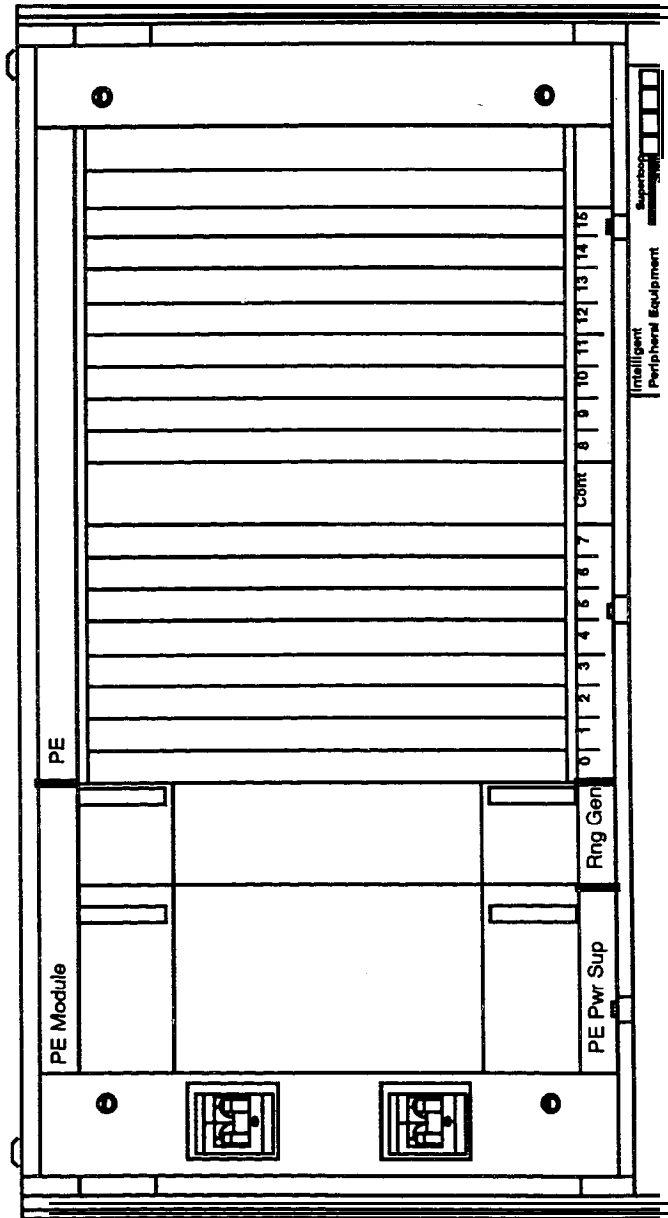
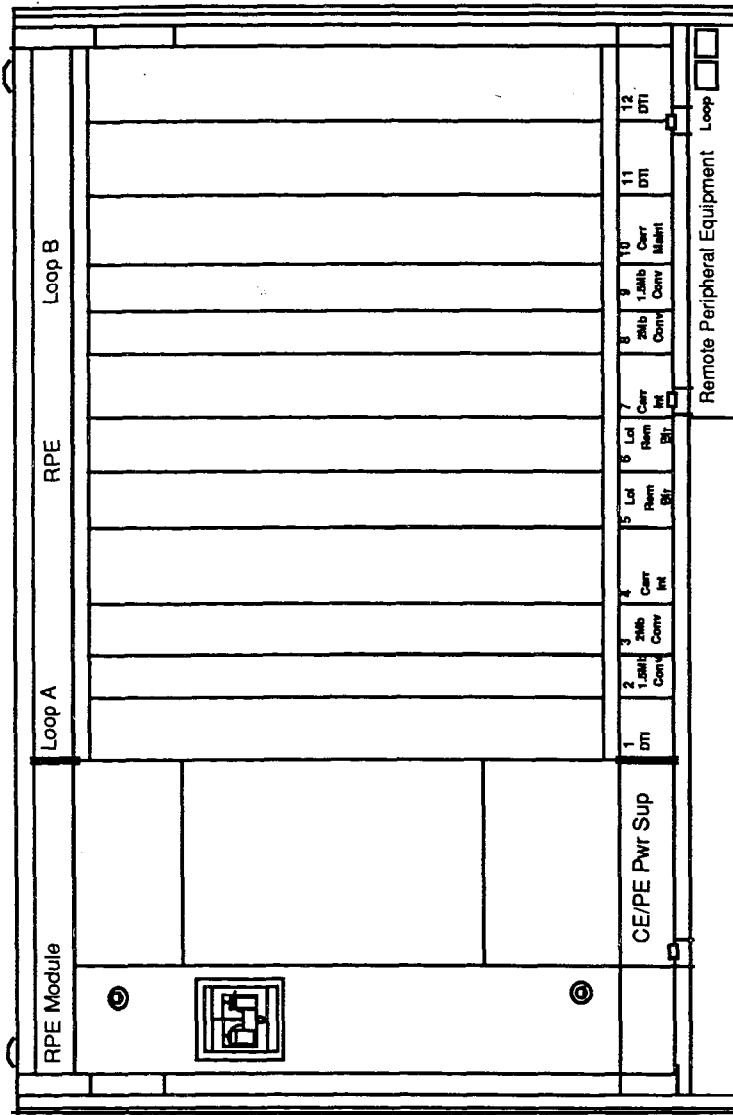

Figure 1-7
 NT8D47 Remote Peripheral Equipment Module



Procedure 1: Installing a circuit pack

General information

This procedure provides detailed installation instructions for SL- 1 system circuit packs. Test procedures for most circuit packs require **that** all internal and external cabling **be** installed. Refer to **System installation procedures (553-3yy1-210)** for cable installation procedures and **Installation procedures for telephone sets and attendant consoles (553-3001-215)** for telephone set and console installation procedures.

When handling electronic equipment, installers should wear an ESD grounding strap. This strap should be connected to the card cage mounting tabs or screws (not on painted or non-metallic surfaces).

Installation procedure

CAUTION

Touch the metal frame of the equipment column to discharge static electricity from your body before handling any circuit pack.

- 1 Open the protective carton and remove the circuit pack from its antistatic container. Return the antistatic container to the carton and store for future **re-use**, or return to supplier.
- 2 Inspect the circuit pack components, faceplate, locking devices and circuit board for damage. If damaged, tag the pack with a description of the defect, return the pack to its antistatic container and protective carton, and return to supplier.
- 3 Refer to work order and determine the shelf location and slot number into which the circuit pack is to be installed.
- 4 Set the **ENB/DIS** switch (ii equipped) on the circuit pack faceplate to **DIS**.
- 5 Set circuit pack address and or option switch settings according to work order. See "Option switch settings" in this document for address and option switch settings.

CAUTION

Incorrectly set switches on Common Equipment (CE) circuit packs may cause a system failure.

- 6 Unhook the circuit pack locking device at the top and bottom of the circuit pack by pushing the tabs at **the** end of the locking devices away from the faceplate.
- 7 **Open** the locking devices by pulling the ends away from the faceplate. The ends pivot outward, one towards the top of the faceplate and the other towards the bottom.
- 8 Insert the circuit pack into the upper and lower aligning guides in the shelf.
- 9 Push the circuit pack into the shelf until resistance is felt.
- 10 Engage **the** circuit pack contacts **firmly** into the shelf connectors by simultaneously pushing the ends of the locking devices inwards against the faceplate.
 - If the circuit pack is a telephone or console pack, a faceplate LED may light. This is not always a fault indication. With intelligent peripherals, a self test of the card is performed on power up. The Card faceplate Light-Emitting Diode (LED) is lit while the self test is performed. If the self test passes, the faceplate LED flashes three times and stays lit until **the** card is enabled in the software. If the test fails, the LED stays lit (and does not flash).
- 11 Secure the locking devices by gently moving the tab on the ends of the devices towards the center of the faceplate.
- 12 **Set the ENB/DIS** switch (if equipped) to **ENB**.

Note: The **ENB/DIS** switch on network circuit packs should only **be** set to **ENB** when the network loop cable is installed,
- 13 Perform this step when adding voice, conference or tone and digit loop. Press **MAN INT** button on **QPC580** if the circuit pack is located in the active CPU.

Note: The **MAN INT** button is located on the NT8D19AAA Memory/Peripheral Signalling Card for system option 21.

- 14 If **the** circuit pack is being installed on a working system, refer to the work order and XII **input/output guide (553-3001-400)** to add **the** required office data to the system memory.
- 15 Perform tests of **the** features and services provided by the circuit pack. Refer to the appropriate procedure in this chapter for individual circuit **packs**.



Procedure 2: Conference Circuit Pest

General information

Use this procedure to test a Conference circuit pack, and to test the conference function of a **Conference/TDS** card

Test procedure

- 1 Log into the system:
LOGI (password)
- 2 Load Overlay 38:
LD 38
- 3 Request the status of conference pack L:
STAT L
 - . Status information for conference pack L is formatted as follows:

CNFC N DSBL N BUSY
number of conferee groups disabled and busy.

CHAN N DSBL N BUSY
number of channels disabled and busy. --

UNEQ
pack is not equipped in the system.

DSBL
pack is disabled in software.
- 4 If conference pack L is disabled, enable it:
For conference pack only, use:
ENLL L

For **Conference/TDS** card use:
ENLX L
where L=theodddloop
If LD 34 is used, L = the even loop.
- 5 If system response is other than OK, refer to X11 *input/output guide* (553-3001-400) to analyze message.

- 6 Test conference pack L for channel, group and switching faults:
CNFC L.
If conference pack L passes tests, output is OK.
- 7 If **the** system **response** is **other than** OK, refer to **XII input/output guide (553-3001-400)** to analyze message.
- 8 Prepare the system for setting up a manual conference call on pack L:
CNFC MAN L C
 - Only one manual conference call is allowed at a time. Any telephone dialing the special service prefix code (SPRE) and the digits 93 will enter the manual conference call. Going on-hook takes that telephone out of the conference call.

Note: If the CNFC MAN L C command is entered from an SL-1 maintenance telephone, the telephone automatically becomes part of the manual conference call. If more than two telephones enter a manual conference call and then go on-hook, establishing a two-party conference call, call processing may reestablish the remaining two telephones as a normal two-party call. This will not occur if only a two-party conference call is established.

- 9 Once a 2-party conference call has been established in Step 8, prepare the TTY for testing various channels and conference groups audibly:
CNFC STEP
 - . One telephone acts as a signal source while the other acts as a monitor.
- 10 Once CNFC STEP has been entered, enter C on **the** command input device to cause the conference to step on to the next available channel. Entering G causes the conference to step on to the next available conferee group. Entering an asterisk (*) will cause the command input device to revert to normal command mode.

- 11 Exit Overlay 38:

Procedure 3: Digitone Receiver Circuit Test

General information

Use this procedure to test the **Digitone** Receiver circuit pack.

Note: The DTR daughterboard connected to a peripheral buffer circuit pack cannot be assigned when **the** PE shelf is used in single loop mode,

Test procedure

- 1 Log into the system:
LOG1 (password)
- 2 Load Overlay 34:
LD34
- 3 Ensure that the **Digitone** receiver to be tested is not disabled:
STAT
 . System responds with the TN(s) of disabled **Digitone** receivers.
- 4 If the **Digitone** receiver to be tested is disabled, enable it:
ENLRLSCU
 . L is loop number, S is **shelf** number, C is the card number and U is the unit number of the **Digitone** receiver.
- 5 Test the desired **Digitone** receiver:
DTRLSCU
- 6 If system response is other than OK, refer to X11 *input/output guide* (553-3001400) to analyze message.
- 7 Exit Overlay 34:

Procedure 4: Line Circuit Test

General information

Use this procedure to test the line circuit pack.

Test procedure

- 1 Log into the system:
LOCI (password)
- 2 Load Overlay 30:
LD 30
- 3 **Perform** a network memory test, continuity test and signal test on loop L, shelf S:
SHLF L S
- 4 If system response is other **than** OK, refer to *X11 input/output guide (553-3001-400)* to analyze message.
- 5 **Exit Overlay 30:**

Procedure 5: Multifrequency Compelled Signalling Circuit Test

General information

Use this procedure provides detailed instructions for testing a **Multifrequency** Compelled Signalling circuit pack.

Test procedure

- 1 Log into the system:
LOCI (password)
- 2 Load Overlay 54:
LD 54
- 3 Test the specified unit:
ATSTLSCU
- 4 If system response is other than **OK**, refer to XI 1 *input/output guide* (553-3001-400) to analyze message.
- 5 Exit Overlay 54:

Procedure 6: Multifrequency Sender Circuit Test

General information

This procedure provides detailed instructions for testing a **Multifrequency** Sender circuit pack.

Test procedure

- 1** Log into the system:
LOG1 (password)
- 2** Load Overlay 46:
LD46
- 3** Enable and test MF sender L:
MFS L
- 4** If system response is other than **OK**, refer to **X11 input/output guide** (553-3001-400) to analyze message.
- 5** Obtain 10 second bursts of digits 1 to 9,0 and 11 to 15 (in that order) from loop L:
TONE L ALL
Ensure that each burst sounds different. If not, replace the circuit pack.
- 6** Exit Overlay 46:
**** ****

Procedure 7: Tone and Digit Switch (TDS) Test

General information

This procedure provides detailed **instructions** for testing a Tone and Digit Switch (TDS) circuit, and for **testing** a **Conference/TDS** card.

TDS test procedure

- 1 Log into the system:
LOCI (password)
- 2 Load Overlay 34:
LD 34
- 3 Obtain a list of **TNS** for disabled TDS packs:
STAT
- 4 If the TDS to be tested is disabled, enable it as loop **L**:
For TDS circuit only, use:
ENLL L

For Conference/IDS card use:
ENLX L
where L = the even loop
If LD 38 is used, L = the odd loop.

ENLL L
- 5 Test the TDS:
TDS L
- 6 If system response is other than **OK**, refer to XII *input/output guide* (553-3001-400) to analyze message.
- 7 Exit Overlay 34:

- 8 Using an SL- 1 maintenance telephone, log into the system:
5644 (password)

- Refer to General *maintenance information* (553-3001-500) for **TTY/Dial Pad** compatibility table.
- 9 Using an SL-1 maintenance telephone, load Overlay 34:
LD# 34# #
 - 10 Using the maintenance telephone, **enter**:
TDS#L##
 - Table I-1 lists the maintenance telephone input commands for testing the **outpulsers** and channels of the TDS at loop L.
 - 11 Exit Overlay 34 from the maintenance telephone:

Table I-1
TDS tone tests

Input Command	Dial Pad Equivalent	Description
BSY# L# #	279# L# #	Provides busy tone from tone and digit loop L.
C# #	2# #	Removes any active tone.
DIA# L# #	342# L# #	Provides dial tone from tone and digit loop L.
OPS# L# X# #	677# L# X# #	Outpulses from tone and digit loop L using the 10 or 20 pps outpulser to any idle trunk. This command connects the SL-1 telephone to the trunk, and a test call on the trunk maybe made using the outpulses selected. When the test call is completed, the program must be reentered by keying SPRE 91 before entering another command, where SPRE denotes the special service prefix, unique for each customer.
OPS# L# X# #	677# L# X# #	Provides override tone from tone and digit loop L (X08 only).
OVF# L# #	683# L# #	Provides overflow tone from tone and digit loop L.
RBK# L# #	725# L# #	Provides ringback tone from tone and digit loop L .
RNG# L# #	764# L# #	Provides ring tone from tone and digit loop L.
****		Exits TDS test program.
*		Cancels tone.

Procedure 8: Network Circuit Test

General information

This procedure provides detailed instructions for testing a network circuit pack.

Test procedure

- 1 Log into the system:
LOGP (password)
- 2 Load Overlay 30:
LD30.
- 3 Perform a network memory test, continuity test and signalling test on loop L:
LOOP L
 - . Parameter L can be the loop number or ALL.
 - . If ALL is specified, all loops enabled when this command is issued are tested. All shelves on each loop are tested (except for attendant consoles).
 - . If only one loop is being **tested**, enter **ENLL L** to enable and test network circuit associated **with** loop L. (This command cannot enable network circuits disabled by Overlay 32.)
- 4 If system response is other than OK, refer to XII **input/output guide** (553-3001-400) to analyze message.
- 5 **Exit Overlay 30:**

Procedure 9: Trunk Circuit Test

General information

This **procedure** provides detailed instructions for testing a trunk circuit pack.

Test procedure

- 1 Log into the system:
LOG1 (password)
- 2 **Load** Overlay 36:
LD36
- 3 Test the trunk circuit:
TRKLSCU

L is loop number, S is shelf number, C is card number and U is unit number.
- 4 If system response is other than OK, refer **to XII input/output guide (553-3001-400)** to analyze the error message.
- 5 To test **ANI** trunks seize a CO monitor trunk:
CALL

Seize the **ANI** trunk to be tested by entering TRK L S C U. When the DN? prompt is displayed, enter 0 or 1 + 7 to 10 digits.
- 6 If system response is other than OK, refer to **553-3001-511** to analyze message.
- 7 **Exit Overlay 36:**

- 8 If AIOD trunk packs are to be tested, load Overlay 41:
LD 41
- 9 Test the AIOD trunk pack:
AIODLSC
- 10 If system response is **other** than OK, refer **to XII input/output guide (553-3001-400)** to analyze message.

11 Exit Overlay 41:



Option switch settings

Chapter contents

Circuit Pack Grid	2-5
NT7D03AA Ringing Generator DC	2-55
NT7D04AA Common/Peripheral Power Supply DC	2-56
NT8D14AA Universal Trunk	2 - 5 7
NT8D15AA E & M Trunk Card jumper settings	2-58
NT8D17AA Conference/TDS settings — SW2	2-59
NT8D17AA Conference/TDS Warning Tone Option strap settings	2-59
NT8D22AB Settings for total number of slave System Monitors (SW2 on Master)	2-63
NT8D22AB Slave System Monitor addresses (SW 2)	2-64
NT8D22AB System Monitor SW1	2-61
NT8D22AB System Monitor SW2	2-62
NT8D22AB System Monitor SW3	2-62
NT8D41 AA Port 1 and 2 address selection switch settings	2-65
NT8D41 AA Port baud rate switch settings	2-65
NT8D41AA Port DTE/DCE mode selection switch settings	2-66
QMT8 SADM	2-51
QMT11 ASIM	2-52
QPA62 CDR 32K PAM	2-6
QPC30 4K RAM	2-7
QPC31 8K RAM	2-8
QPC33 tape unit interface	2-8
QPC41 miscellaneous	2-9
QPC43 peripheral signaling	2-9
QPC45 Serial Data Interface	2-9
QPC46/155 CE bus extender	2-10
QPC62 1.5 MBaud converter	2-10

2-2 Option switch settings

QPC66 2.0 MBaud converter	2-11
QPC70/217/293 CO/FX/WATS	2-11
QPC71/287 E&M/DX/Paging	2-12
QPC72/288/449/559/560 Loop Signaling	2-13
QPC72M loop signaling	2 - 5 1
QPC73/289 Dictation	2-13
QPC74/290 Recorded Announcement	2-14
QPC84 Power Monitor	2-15
QPC99 Carrier interface	2-19
QPC139 SDI	2-20
QPC173 Power Monitor	2-21
QPC197 TDS	2-22
QPC214 Memory Controller	2-22
QPC215 Segmented Bus Extender	2-23
QPC216 3-Port Extender	2-23
QPC218/272 CO/FX/WATS	2-23
QPC218F CO/FX/WATS	2-24
QPC219/295 CO/FX/WATS	2-24
QPC237A/237B/296A/296B 4W E&M/DX	2-25
QPC237C 4W E&M/DX	2-26
QPC237D/237E/296C 4W E&M/DX	2-27
QPC239/294 Recorded telephone dictation	2-27
QPC327 MFC Sender/Receiver	2-28
QPC330,331 Buffered Message Register Trunk	2-28
QPC377/379 Conference	2-29
QPC387 Peripheral buffer	2-29
QPC390/391 Pulsed E&M trunk	2-30
QPC414 dual network	2-31
QPC417 Junctor Board	2-31
QPC423 192K RAM	2-32
QPC425 CPU and SDI	2-32
QPC426 192K RAM	2-33
QPC432 Four Port Data Line Card	2-33
QPC441 3-Port Extender	2-34
QPC446/447 Conference	2-34
QPC450/528 CO/FX/WATS	2-35
QPC464 Peripheral Buffer	2-37
QPC471 Clock Controller option settings	2-37
QPC472 Digital Trunk Interface Transmission Equalization	2-38
QPC479 128K RAM	2-38

QPC503 CE Backplane	2-39
QPC513 Enhanced Serial Data interface	2-39
QPC525/526/527 CO trunk	2-40
QPC550A 600/900 OHM impedance selection	2-41
QPC550A Software/hardware control for 2dB pad	2-41
QPC550A/B DID trunk real/complex balance impedance selection	2-40
QPC550B Attenuation level control	2-42
QPC550B hardware control for 2 dB pad	2-42
QPC551 Radio Paging Trunk	2-43
QPC574/595 Digitone Receiver	2-44
QPC577/596 Digitone Receiver Daughterboard	2-44
QPC584 Mass Storage Interface	2-44
QPC650/651 Music trunk	2-45
QPC659 Dual Loop Peripheral	2-45
QPC672 512K memory	2-46
QPC673 512K memory (with error correction)	2-46
QPC674 256K memory with error correction	2-47
QPC687 CPU with SDI/RTC/ROM	2-47
QPC699 CE backplane	2-48
QPC720 Primary Rate Interface Transmission Equalization Switch	2-49
QPC742 Floppy disk interface	2-49
QPC757 D-channel interface card	2-50
QPC775 clock controller	2-51
QPC841 QSDI Port 1 and 2 address selection	2-53
QPC841 QSDI Port 3 and 4 address selection	2-53
QPC841 QSDI Port baud rate switch settings	2-54
QPC841 QSDI Port DTE/DCE mode selection	2-54

Switch locations

The switch settings listed in this document are given in terms of switch location, switch number, and ON or **OFF**. Switch, jumper, and plug block locations on the circuit pack are specified in terms of coordinates (Figure 2-1). To locate a circuit pack option switch, find the intersection point between the alpha (A to G) and numeric (5 to 37) coordinates.

Once the switch block is located on the circuit **pack, individual** switch numbers are shown on the switch block itself, along with ON and OFF settings. In this **document:**

-a bullet (•) denotes ON

-a circle (○) denotes OFF

If **neither** is given (i.e., blank space), the switch is not applicable for that option.



Figure 2-1
Circuit Pack Grid

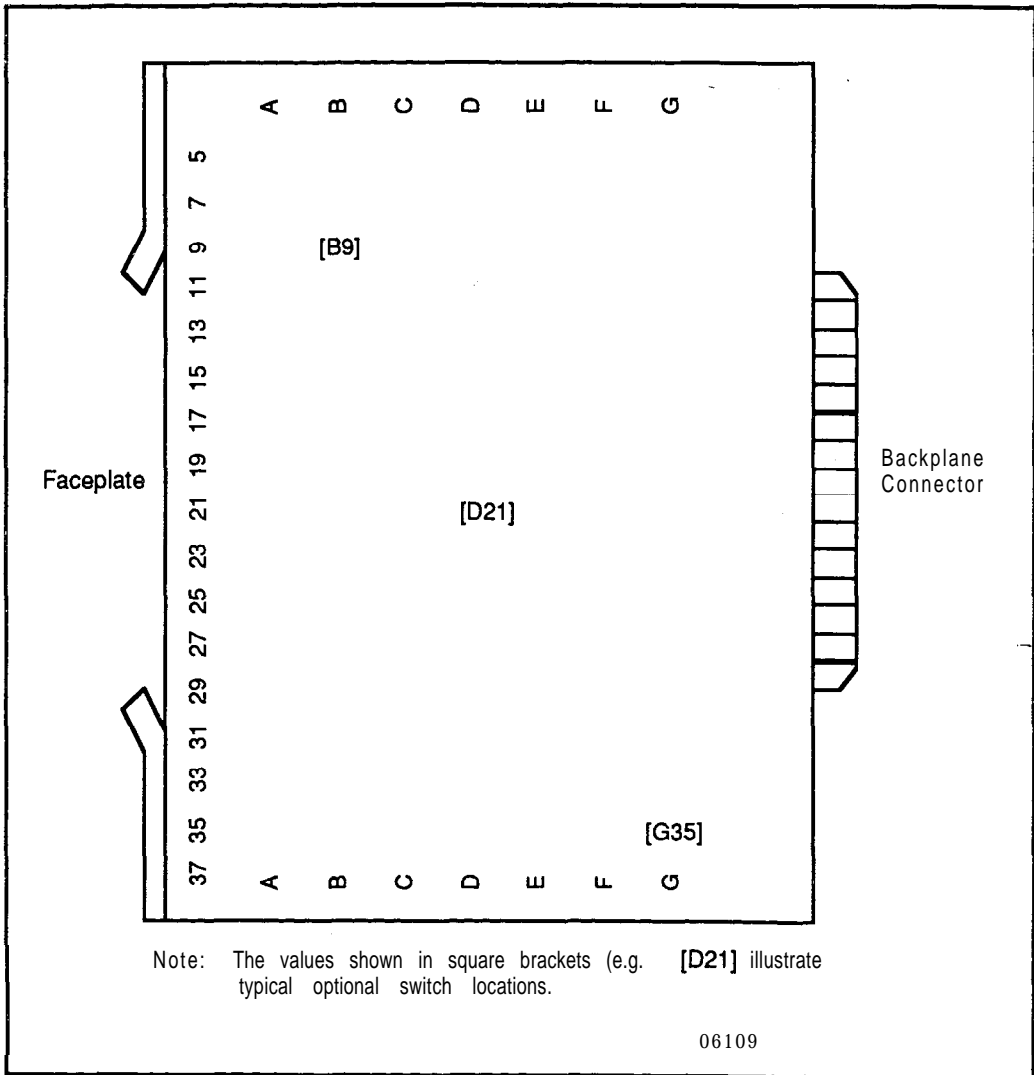

Table 2-1
QPA62 CDR 32K RAM

Circuit pack vintage	Switch location	switch settings							
		1	2	3	4	5	6	7	8
C, E and G	E1	0	0	●	0	0	0	0	0
	G5	0	0	●	0	0	0	0	0
	F18	0	0	●	0	●	0	●	0
D	F5	0	0	.	0	0	0	0	0
	G5	0	0	0	0	0	0	0	0
Fand H	F5	0	0	0	0	0	0	0	0
	G5	0	0	0	●	0	0	0	0

Note: The QPA62 switch settings depend on the circuit pack vintage. **Check** the vintage identified on the **faceplate** and set the switched as shown.

Table 2-2
QPC30 4K RAM

Address selection													
Device number	E5 switch						Device number	E5 switch					
	2	3	4	5	6	7		2	3	4	5	6	7
0	○	○	○	○	○	○	24	○	○	○	●	●	○
1	●	○	○	○	○	○	25	●	○	○	●	●	○
2	○	●	○	○	○	○	26	○	●	○	●	●	○
3	●	●	○	○	○	○	27	●	●	○	●	●	○
4	○	○	●	○	○	○	28	○	○	●	●	●	○
5	●	○	●	○	○	○	29	●	○	●	●	●	○
6	○	●	●	○	○	○	30	○	●	●	●	●	○
7	●	●	●	○	○	○	31	●	●	●	●	●	○
8	○	○	○	●	○	○	32	○	○	○	○	○	●
9	●	○	○	●	○	○	33	●	○	○	○	○	●
10	○	●	○	●	○	○	34	○	●	○	○	○	●
11	●	●	○	●	○	○	35	●	●	○	○	○	●
12	○	○	●	●	○	○	36	○	○	●	○	○	●
13	●	○	●	●	○	○	37	●	○	●	○	○	●
14	○	●	●	●	○	○	38	○	●	●	○	○	●
15	●	●	●	●	○	○	39	●	●	●	○	○	●
16	○	○	○	○	●	○	40	○	○	○	●	○	●
17	●	○	○	○	●	○	41	●	○	○	●	○	●
18	○	●	○	○	●	○	42	○	●	○	●	○	●
19	●	●	○	○	●	○	43	●	●	○	●	○	●
20	○	○	●	○	●	○	44	○	○	●	●	○	●
21	●	○	●	○	●	○	45	●	○	●	●	○	●
22	○	●	●	○	●	○	46	○	●	●	●	○	●
23	●	●	●	○	●	○	47	●	●	●	●	○	●

Note: Switch 1 is set to OFF for normal operation and set to ON for circuit pack debugging. Switch 8 is set to ON only when the pack is used as the spare.

Table 2-3
QPC31 8K RAM

Address selection													
Device number	E5 switch						Device number	E5 switch					
	2	3	4	5	6	7		2	3	4	5	6	7
0	○	○	○	○	○	○	12	○	○	○	●	●	○
1	○	●	○	○	○	○	13	○	●	○	●	●	○
2	○	○	●	○	○	○	14	○	○	●	●	●	○
3	○	●	●	○	○	○	15	○	●	●	●	●	○
4	○	○	○	●	○	○	16	○	○	○	○	○	●
5	○	●	○	●	○	○	17	○	●	○	○	○	●
6	○	○	●	●	○	○	18	○	○	●	○	○	●
7	○	●	●	●	○	○	19	○	●	●	○	○	●
8	○	○	○	○	●	○	20	○	○	○	●	○	●
9	○	●	○	○	●	○	21	○	●	○	●	○	●
10	○	○	●	○	●	○	22	○	○	●	●	○	●
11	○	●	●	○	●	○	23	○	●	●	●	○	●

Note: Switch 1 is set to OFF for normal operation and set to ON for circuit pack debugging. Switch 8 is set to ON only when the pack is used as the spare.

Table 2-4
QPC33 tape unit interface

Address selection		
Tape unit	E8 switch	
0	○	● ●
1	●	○ ●
2	●	● ○
3	○	○ ○

Note 1: Main system tape units are assigned as tape unit 0. In dual CPU systems both QPC33 are assigned as tape unit 0.

Note 2: Use tape unit 1 for Mini-CDR feature.

Table 2-5
QPC41 miscellaneous

Memory configuration				
	B5 switch			
	1	2	3	4
SL-1 S, MS	•	○	○	•
SL-1 A with Split Mode	○	○	•	○
All other SL-1 systems	○	○	○	•

Table 2-6
QPC43 peripheral signaling

Options	Plug location
QSD39, QSD40, QSP31, QSP32 Network shelves	F13
Other Network shelves	F9

Note: These options apply to QPC43N and later vintages only.

Table 2-7
QPC45 Serial Data Interface

Address selection		Speed selection		Output device	
Device number	C15 switch	Baud rate	B15 switch	Plug location	
	4 5 6		1 2 3		
0	• • •	110	• ○ ○	TTY	A15
1	○ • •	300	○ ○ ○		
2	• ○ •	1200	○ ○ •	Modem	B5
3	○ ○ •	2400	○ • ○		
4	• • ○	4800	○ • •	EIA data terminal	B10
5	○ • ○				
6	• ○ ○				
7	○ ○ ○				

Table 2-8
QPC46/155 CE bus extender

Application	QPC46 A35 switch						QPC155 A35 switch					
	1	2	3	4	5	6	1	2	3	4	5	6
CPU located at extension end of the bus	0	0	0	0	0	0	0	0	0	0	0	0
CPU not located at extension end of the bus	0	0	0	0	0	0	0	0	0	0	0	0
Basic system (QPC155)												
Expanded System (QPC155)							0					

Table 2-9
QPC62 1.5 MBaud converter

Carrier A and B options (Note 1) Distance to ORB		Switch settings (Note 2) SW1 and SW2							SW3	
(Feet)	(Meters)	1	2	3	4	5	6	7	6	
0 - 150	0 - 45 (Note 3)	○	○	●	●	○	●	●	○	6V
151 - 450	46 - 147	○	●	●	○	●	●	○	●	12V
451 - 750	148 - 229	●	○	○	●	●	○	●	●	12V

Note 1: If both circuit packs provided are QPC62E, or packs of later vintage, insert the plug-in jumper (U-link) between header pins 1 and 2 (located at 825). If any circuit pack provided is QPC62D, or packs of earlier vintage, insert the plug-in jumper (U-link) between header pins 2 and 3. On systems equipped with dual network packs, QPC62E or packs of later vintage must be provided.

Note 2: Switch 1 (SW1) is set for carrier A and Switch 2 (SW2) is set for Carrier B. SW3 refers to the faceplate toggle switch.

Note 3: Set to the 0 - 150 ft range when interfacing directly with carrier (for example, without going through an Office Repeater Bay).

QPC66 2.0 MBaud converter

Option strap settings

If both circuit packs provided are **QPC66D**, or packs of later vintage, insert the plug-in jumper (Wink) between header pins 1 and 2 (located at B35). If any circuit pack provided is **QPC66C**, or packs of later vintage, insert the plug-in jumper (U-link) **between header** pins 2 and 3. On systems equipped with dual network packs, **QPC66D** or packs of later vintage must be provided.

Table 2-1 0
QPC70/217/293 CO/FX/WATS

Application	Port0 E35 switch						Port 1 ES switch					
	1	2	3	4	5	6	1	2	3	4	5	6
Loop Start, 24 V CO Battery	○	●	●	●	○	●	○	●	●	●	●	○
Loop Start, 48 V CO Battery	○	○	●	○	○	●	○	●	○	○	●	○
Ground Start, 24V CO Battery	.	.	○	.	○	○	●	□	□	□	□	□
Ground Start, 48 V GO Battery	●		□	□	□	□	●	○	○	○	○	○

Table 2-1 1
QPC71/287 E&M/DX/Paging

Application	Port 0 E35 switch								Port 1 E5 switch							
	1	2	3	4	5	6	7	8	1	2	3	4	5	6	7	8
E&M	0	0	0	0	0	0	0	0	0	0	0	0	0	0	0	0
Paging	0	0	0	0	0	0	0	0	0	0	0	0	0	0	0	0
DX 2-Wire (Conductor loop < 2.5 kΩ)	•	•	0	0	0	•	0	•	•	•	0	0	0	•	0	•
DX 2-Wire (Conductor loop > 2.5 kΩ)	•	•	•	•	0	•	0	•	•	•	•	•	0	•	0	•
DX 4-Wire (Conductor loop < 2.5 kΩ)	0	0	0	0	•	•	0	•	0	0	0	0	•	•	0	•
DX 4-Wire (Conductor loop > 2.5 kΩ)	0	0	•	•	•	•	0	•	0	0	•	•	•	•	0	•

Note: DX trunks must be balanced correctly. If loop < 2.5 kΩ, the far end balancing is standard. If loop > 2.5 kΩ, the far end balancing requires standard plus 2.5 kΩ. To connect SL-1 to SL-1, switches should be arranged for loop > 2.5 kΩ at one end and < 2.5 kΩ at the other. Apply similar treatment when connecting to Pulse QPJ69 trunks.

Table 2-12
QPC72/288/449/559/560 Loop Signaling

Application	Single density	Double density
	Port 0/1 F30/F8 (Note) switch	Port 0/1/2/3 H17/H3/A17/A3 switch
	1 2 3 4 5 6	1 2 3 4 5 6
Outgoing ANI only:		
loop pulsing	0 0 0 0 0 0	0 0 0 0 0 0
battery and ground pulsing	0 0 0 0 . 0	0 0 0 0 . 0
Other than Outgoing ANI	● □ □ □ □ □ □	● ○ ● ○ ● ○
Jumpers (QPC560)		
Units 0/1/2/3		
600R Resistive impedance		pins 1 to 2
3-Component Complex Impedance		pins 2 to 3
Note: On the QPC72M Loop Signalling (CSA SDT C22.2), this switch location is E27/E11.		

Table 2-13
QPC73/289 Dictation

Application	Port0	Port 1
	D35 switch	D5 switch
	1 2 3 4	1 2 3 4
Recorded Telephone Dictation Application		
External resistance c 430R	0 0 0 0	0 0 0 0
External resistance > 430R	● ○ ○ ○	● ○ ○ ○

Table 2-1 4
QPC74/290 Recorded Announcement

Application	Port 0 C35 switch				Port 1 F35 switch				Port 2 C5 switch				Port 3 F5 switch			
	1	2	3	4	1	2	3	4	1	2	3	4	1	2	3	4
Connected to:																
Code-A-Phone	0	.	0	0	○	●	○	○	0	.	0	0	0	.	0	0
Cook Digital Announcer (Start/Stop)	0	.	0	0	0	.	0	0	0	.	0	0	0	.	0	0
Audichron	○	○	●	○	0	0	.	0	0	0	.	0	0	0	.	0
Cook Digital Announcer (continuous run)	○	○	●	○	0	0	.	0	○	○	●	○	0	0	.	0
Test or Music (60042 source Z)	●	○	○	●	●	○	○	●	●	○	○	●	●	○	○	●

Table 2-15
QPC64 Power Monitor

Options	Switch (Note 1)							
QPC84A to L (M2)								
66 V Ringing Generator falls	1	2	3-4	5	6'7	8		
allows alarm and line transfer	●	0						
allows alarm, defeats transfer	0	0						
defeats alarm and transfer	0	.						
48V Regulator falls	1	2	3	4	5	6	7	8
allows alarm and line transfer			0				.	
allows alarm, defeats transfer			0				0	
defeats alarm and line transfer			.				0	
System equipped with reserve battery	1	2	3	4	5	6	7	8
allows trip input				.				
defeats trip input				0				
MO V fails (CONV 1)	1	2	3	4	5	6	7	8
allows line transfer					.			
defeats line transfer					0			
±10 V fails (CONV 2)	1	2	3	4	5	6	7	8
allows line transfer						.		
defeats line transfer						0		
Reset button	1	2	3	4	5	6	7	8
allows reset function								.
defeats reset function								0
<p>Note 1: The switch locations depend on circuit pack vintages: QPC84A to K - located at A5 QPC84L - located at D18</p> <p>Note 2: Alarm refers to QPC84 LEDs, cabinet LEDs, remote alarm, CE alarm (Initiate internal diagnostics).</p> <p>Note 3: PWR, FAN and TEMP LEDs are not functional when QPC84 is located in a PE cabinet.</p> <p style="text-align: center;">— continued —</p>								

Table 2-15
QPC84 Power Monitor (continued)

Options	D29 switch								C11 switch							A4 (QPC84R/S) switch							
	1	2	3	4	5	6	7	8	1	2	3	4	5	6	7	1	2	3	4	5	6	7	8
QPC84 P to s															- 7								
Option A (Note 4)																•	○	•					
Option B (Note 4)																0	.	0					
86 V Ringing Generator fails																							
allow alarm and line transfer																							
allow alarm, defeats transfer																○	○						
defeat alarm and transfer																○	.						
48V Regulator fails																							
allow alarm and line transfer																•						•	
allow alarm, defeat transfer																.						○	
defeat alarm and line transfer																○						○	
System equipped with reserve battery																							
allow trip input																							
defeat trip input																						○	
±10 V fails (QSP43/44 shelf)																							
allow line transfer																						•	○ ○
defeat line transfer																						○	0000
±10 V fails (CONV 1)																							
allow line transfer																							00.
defeat line transfer																						○	0 0 0

— continued —

Table 2-15
QPC84 Power Monitor (continued)

options	D29 switch								C11 switch								A4 (QPC84R/S) switch																						
QPC84 P to S																																							
±10 V fails (CONV 2)	1	2	3	4	5	6	7	8	1	2	3	4	5	6	7	1	2	3	4	5	6	7	8	1	2	3	4	5	6	7	8								
allow line transfer						.					0	0		.																									
defeat line transfer						0					00		0																										
Reset Button																																							
	1	2	3	4	5	6	7	8																															
allow reset						.																																	
defeat reset						0																																	
CE Power Failure (Note 5)																																							
allows remote alarm and SYSLTOUT signal									1	2	3	4	5	6	7	1	2	3	4	5	6	7	8																
defeats remote alarm and SYSLTOUT signal									0																														
Monitoring of FAIL and CTR (Note 3) signal																																							
defeats monitoring (SL-1 XN/QCA108 cabinet)									1	2	3	4	5	6	7	1	2	3	4	5	6	7	8																
allows monitoring (all other systems)									0																0														
Monitoring cooling unit failure																																							
defeats monitoring (SL-1 N/QCA58 or QCA108, SL-1 MS/ QCA109 cabinet with half-group configuration)									1	2	3	4	5	6	7	1	2	3	4	5	6	7	8																
allows monitoring (all other configurations)																								0															
Note 1: Alarm refers to QPC84 LED, cabinet LED, remote alarm, CE alarm (to initiate internal diagnostics)																																							
Note 2: PWR, FAN and TEMP LED's are not functional when the QPC84 is located in a PE cabinet.																																							
— continued —																																							

Table 2-15

QPC84 Power Monitor (continued)

QPC84 P to S	D29 switch	C11 switch	A4 (QPC84R/S) switch
Note 3 : The A4 (QPC84S) switch 8 is operated when monitoring of the CTR signal is required.			
Note 4: Options A and B applies to QPC84R only. Switch A4 is set in the appropriate option setting based on the cabinet type and vintage suffix. Refer to the chart below for option selection.			
Note 5 : The C1 1 Switch 1 must be on for QCA1 108 cabinets.			
Cabinet type	Vintage	Option A	Option B
QCA6	all vintages		X
QCA7	all vintages		X
QCA8	all vintages		X
QCA23	all vintages		X
QCA28	all vintages		x
QCA37	all vintages		X
QCA58	A thru E		X
*QCA58	EI only	X	
QCA58	F1 and later		X
QCA60	all vintages		X
QCA74	A thru E		X
*QCA74	EI only	X	
QCA74	F1 and later		X
QCA96	all vintages		X
QCA108	A thru E		X
● QCA108	EI only	X	
QCA108	F1 and later		X
QCA109	A and later		X
* If a vintage A - QSP43 or QSP44 converter shelf is equipped, then the switch must be set in the Option B mode.			

Table 2-16
QPC99 Carrier Interface

Carrier shelf location	interface equipment	A20 option switch						F25 pad switch					
		1	2	3	4	5	6	7	8	9	10	11	12
Local end	ORB at local end (Pads in)	0	0	0	.	0	.	●				<input type="checkbox"/>	<input type="checkbox"/>
	Direct to LD-1 or GTE Lenkurt Carrier (No ORB at Local end) (Pads out)	o	o	o	.	.	.	o	o	o	o	.	.
Remote end	ORB at Remote End (Pads in)	.	o	.	o	o	o	o
	Direct to LD-1 or GTE Lenkurt Carrier (No ORB at Remote end) (Pads out)	.	o	.	o	.	.	o	o	o	o	●	.

Note: Consult manufacturer for switch settings when circuit pack interfaces with other type of carrier equipment.

Table 217
QPC139 SDI

Address selection		Speed selection								Output device						
Device number	F7 switch				Baud rate	Port 1 C34 switch				Port 2 C22 switch				Port 1 plug location	Port 2 plug location	
	1	2	3	4		1	2	3	4	1	2	3	4			
0-1	○	●	●	●	110	0	.	.	.	○	●	●	●	Modem	A13	A25
2-3	0	.	0	0	150	0	0	.	.	0	0	.	.			
4-5	0	.	0	.	300	0	.	0	.	○	●	○	●	EIA data terminal	A16	A22
6-7	0	.	0	0	600	○	○	○	●	0	0	0	.			
8-9	0	0	.	.	1200	○	●	●	○	0	.	0	0			
10-11	○	○	●	○	2400	0	0	.	0	○	○	●	○			
12-13	0	0	0	.	4800	0	.	0	0	0	.	0	0			
14-15	0	0	0	0	9600	0	0	0	0	0	0	0	0			

Note 1: Switches at D22 and D31 are not used and set to OFF.

Note 2: Option is used to extend RS232C cable limit.

Table 2-16
QPC173 Power Monitor

Options	A31 switch							
	1	2	3	4	5	6	7	8
Vintages QPC173 A to D								
Option A (Note 2)	•	○	•					
Option B (Note 2)	○	•	○					
Allow Reset button fo function (SL-1 VL only)						.		
Defeat Reset Button function (SL-1VLE/XL/XN)						○		
Allow Trip input (Note 1)						.		
Defeat Trip input							○	
Systems equipped with one QCA25 (QCA14) cabinet or QCA55 cabinet equipped with 1 group							.	.
Systems equipped with two QCA25 (QCA14) cabinets or QCA55 cabinet equipped with 2 or 3 groups							•	○
Note 1: Switch 5: Applies to QPC173C and later vintages only.								
Switch 6: If Trip input is required, switch 6 must be ON to allow the -48 V cabinet input switches of QCA24 (QCA10), QCA25 (QCA14), QCA8 and QCA55 cabinets to trip when battery voltage is < 43.5 V. If Trip input is not required, switch 6 should be OFF.								
Switch 7: Must be ON for Temperature Monitoring even when system is equipped with 2 or 3 groups.								
Switch 8: Must be OFF for Fan Alarm Monitoring when system is equipped with more than one group.								
Note 2: Option A and B applies to QPC173D only. Switch A31 is set in the appropriate option setting based on the cabinet type and vintage suffix. Refer to the chart below for option selection.								
Cabinet type	Vintage	Optbn A	Option B					
QCA10	all vintages		X					
QCA24	all vintages		X					
QCA55	A thru E		X					
*QCA55	EI only	X						
QCA55	F1 and later		X					
** if a vintage A - QBL21 distribution shelf is equipped, then the switch must be set in the Option B mode.								

Table 2-19
QPC197 TDS

Options	Jumper plug locatkins
SL-1 set ringing:	
Audible ringing of 533/666 Hz modulated at:	
10 Hz - connect pins 1 and 2	B5
20 Hz - connect pins 2 and 3	B5
Dial Tone Level:	
Low dial tone level, 23 dB below overflow level:	
connect pins 1 and 2	B10
High dial tone level, 19 dB below overflow level:	
connect pins 2 and 3	B10
Note: The Ringing and Dial Tone Level options apply to QPC197C and later vintages only.	

Table 2-20
QPC214 Memory Controller

Memory option	QPC214A, B or C A35 switch								QPC214D A35 switch			
	1	2	3	4	5	6	7	8	1	2	3	4
SL-1 A Standard	○	●	○	○	○	●	○	○	0	0	.	0
SL-1 A Split Store	●	□	□	□	□	□	□	□	●	○	●	○
SL-1 LE Standard	0	0	0	0	0	0	0	0	0	0	0	0
SL-1 LE Split Store	0	0	0	0	0	0	0	0	●	○	○	○
SL-1 VLE/XL Standard	0	0	0	0	0	0	0	0	0	0	0	0
SL-1 M Standard	.	●	○	○	○	○	○	○	.	●	○	○

Table 2-21
QPC215 Segmented Bus Extender

Network group	Network group					Memory access	
	D3 switch					D3 switch	
	2	3	4	5	6	1	
0	cl	Page 3 access	.
1	o	.	.	.	o	Page 7 access	o
2	o	.	.	o	.		
3	o	.	.	o	o		
4	o	.	o	.	.		
To MGC	o	o	o	o	o		

Table 2-22
QPC216 3-Port Extender

Application	A20 switch			
	1	2	3	4
Half network group	.	0		
Full network group	0	0		
Page 3 address			.	
Page 7 address			o	
SL-1 multi-group systems				.
SL-1 single-group systems				o

Table 2-23
QPC218/272 CO/FX/WATS

Application	Port0 E35 switch						Port 1 E5 switch					
	1	2	3	4	5	6	1	2	3	4	5	6
Loop start	0	0	0	0	0	0	0	0	0	0	0	0
Loop start with Automatic Guard Detection	o	o	.	o	o	o	o	o	.	o	o	o
Ground start	.		<input type="checkbox"/>	<input checked="" type="checkbox"/>	<input type="checkbox"/>	<input type="checkbox"/>	.	o	.	o	o	o

2-24 Option switch settings

Table 2-24

QPC218F CO/FX/WATS

Application	Port 0	Port 1
	F27 switch	F9 switch
	1 2 3 4 5 6 7 - 8	1 2 3 4 5 6 7 8
Loop start	○ ● ○ ○ ○ ○ ○ ●	0 . 0 0 0 0 0 .
Loop start with Automatic Guard Detection	○ ● ● ○ ○ ○ ○ ●	0 . 0 0 0 0 0 0 1
Ground start	○ ● ● ○ ○ ● ○ ●	○ ● ○ ○ ○ ● ○ ●

Table 2-25

QPC219/295 CO/FX/WATS

Application	Port0	Port1
	E35 switch	E5 switch
	1 2 3 4 5 6 7 8	1 2 3 4 5 6 7 8
Loop start		
Third wire battery on M lead	○ ○ ○ ○ ● ○	○ ○ ○ ○ ● ○
Third wire ground on M lead	○ ○ ○ ○ ○ ●	○ ○ ○ ○ ○ ●
Second pair (M & MM)	○ ○ ○ ○ ○ ○	○ ○ ○ ○ ○ ○
Automatic Guard Detection	○ ○ ●	○ ○ ●
Ground Start		
Third wire battery on M lead	● □ ∩ □ ∩ □	● ○ ● ○ ● ○
Third wire ground on M lead	● □ ∩ □ □ ∩	● □ ∩ □ □ ∩
Second pair (M & MM)	● ○ ● ○ ○ ○	● □ ⊗ □ □ □
900Ω termination (note)		● ●
600R termination (note)	□ □	○ ○
Note: QPC219E and later vintages.		

Table 2-26
QPC237A/237B/296A/296B 4W E&M/DX

Application	Switches																		
	S1(E34)						S2(F20)						S6(D31)						
Port 0:	S3(E4)						S4(F7)						S5(D3)						
Port 1:	1	2	3	4	5	6	1	2	3	4	5	6	1	2	3	4	5	6	
E&M Type I	0	0	0	.	0	0	•	○	•	•	○	•	0	0	0	0	0	0	
E&M Type II	0	0	.	0	0	0	•	•	○	○	•	○	0	0	0	0	0	0	
DX 4-Wire A1 lead to T1, B1 lead to T2																			
• conductor loop < 2.5 kΩ	○	•	○	•	•	○	0	0	0	.	0	0	○	•	○	•			
• conductor loop > 2.5 kΩ	•	•	○	•	•	○	•		□	□	□	□	□	□	□	□			
DX 4-Wire A 1 lead to T2, B1 lead to T1																			
• conductor loop < 2.5 kΩ	○	•	○	•	•	○	○	○	○	•	○	○	.	0	.	0			
• conductor loop > 2.5 kΩ	•	•	○	•	•	○	•		□	□	⊗	□	□	•	○	•	○		
Interface																			
carrier interface																		•	•
public network																		0	0

Table 2-27
QPC237C 4W E&MDX

Application	Switches																			
	S1 (D28)						S2(D31)						S6(E26)				S8 (F33)			
Port 0:	S1 (D28)						S2(D31)						S6(E26)				S8 (F33)			
Port 1:	S3(D10)						S4(D7)						S5(E12)				s7 (S4)			
	1	2	3	4	5	6	1	2	3	4	5	6	1	2	3	4	1	2	3	4
E&M Type I	0	0	0	.	0	.	o	o	.	.	o	o	0	0	0	0				
E&M Type II	o	o	o	o	o	.	o	.	o	o	.	o	0	0	0	0				
British Telecom	o	o	o	o	.	.	o	o	.	o	o	o	0	0	0	0				
DX 4-wire lead t AI to T1, B1 to T2	.	.	.	o	o		.	o	.	.	o	o	o	.	o	.	.		.	
DX 4-wire lead t AI to T2, B1 to T1	.	.	.	o	o		.	o	.	.	o	o	.	o	.	o	.		.	
conductor loop > 2.5 kΩ	.																			
conductor loop < 2.5 kΩ	o																			
Interface																				
Carrier interface																	.		.	
Public network																	o		o	

Table 2-28
QPC237D/237E/296C 4W E&M/DX

Application	Switches																							
	TRK 0: S1 (D33)										S3 (E25)						S4 (B33)							
	TRK 1: S2 (D5)										S5 (E13)						S6 (B5)							
	1	2	3	4	5	6	7	8	9	10	1	2	3	4	5	6	1	2	3	4	5	6		
E&M Type I	0	0	0	0	0	0	0	0	0	0	0	0	0	0	0	0		
E&M Type II	0	0	0	0	0	0	0	0	0	0	0	0	0	0	0	0		
British Telecom	0	0	0	0	0	0	0	0	0	0	0	0	0	0	0	0		
DX 4-wire:																								
M lead to T1, E lead to T2	0	.	0	.			.	.	0	0	0	0	0	0	0		
M lead to T2, E lead to T1	.		□	□	□	□	.	.	0	0	0	0	0	0	0		
Conductor loop > 2.5 kΩ																								
Conductor loop < 2.5 kΩ																								
For carrier interface																								
For ESN																								

Table 2-29
QPC239/294 Recorded telephone dictation

Application	Port0 D33 switch				Port 1 D8 switch			
	1	2	3	4	1	2	3	4
	Transmission During Dialing							
Yes	0	0	0	0	0	0	0	0
No	.	□	□	□	.	0	0	0

2-28 Option switch settings

Table 2-30
QPC327 MFC Sender/Receiver

Options		Jumper plug location
A-Law operation	connect pins 2 and 3	A35
μ-Law operation	connect pins 1 and 2	A35

Table 2-31
QPC330,331 Buffered Message Register Trunk

Application	Port 0 E35 switch						Port 1 E5 switch					
	1	2	3	4	5	6	1	2	3	4	5	6
Loop Start (Accumulated Pulsing)												
Third wire battery on M lead	0	0	0	0	.	0	○	○	○	○	●	○
Third wire ground on M lead	○	○	○	○	○	●	○	○	○	○	○	●
Second pair (M & MM)	0	0	0	0	0	0	0	0	0	0	0	0
Ground Start (Accumulating)												
Third wire battery on M lead	●	○	●	○	●	○	●	○	●	○	●	○
Third wire ground on M lead	●	○	●	○	○	●	●		☒	☒	☒	☒
Second pair (M & MM)	●		☐	☐	☐	☐	●	○	●	○	○	○
Regular CC trunk (same as QPC219)	○	●	○	●	○	○	○	●	○	●	○	○

Table 2-32
QPC377/379 Conference

Options	Strap location
Enable warning tone Insert strap from E20 to ENB	D1
Disable Warning Tone Insert strap from EI 9 to DIS	D1

Table 2-33
QPC387 Peripheral buffer

Ringings voltage	A35 switch
	5 6 7 8
16 Hz, 86 Vrms superimposed on -48 V	● ○ ○ ○
20 Hz, 86 Vrms superimposed on -48 V	0 . ○ .○
25 Hz, 75 Vrms superimposed on -48 V	0 0 . 0
50 Hz, 70 Vrms superimposed on -48 V	0 0 0 .

Table 2-34
QPC390/391 Pulsed E&M trunk

Application		Switches (Note)																		
		S1 (D30)						S2(D25)						S6(F35)						
Port 0:		S3(D30)						S4(D15)						S5(F5)						
		1	2	3	4	5	6	1	2	3	4	5	6	1	2	3	4	5	6	
Pulsed E&M Type I																				
North America		0	0	0	.	0	0	o	o	.	.	o	o	0	0	0	0	0	0	
Norway		0	0	.	0	.	0	0	0	.	0	0	0	0	0	0	0	0	0	
British Post Office		0	0	0	.	0	0	0	0	.	0	0	0	0	0	0	0	0	0	
Pulsed E&M Type II																				
North America		0	0	0	0	0	0	0	.	0	0	.	0	0	0	0	0	0	6	
Norway		0	0	.	0	0	0	o	.	o	o	.	o	0	0	0	0	0	0	
British Post Office		0	0	0	0	0	0	o	.	o	o	.	o	0	0	0	0	0	0	
DX 4-Wire M-lead to T1, E-lead to T2																				
Norway		.	.	o	.	o	0	0	0	0	o	.	o	.	.	.				
British Post Office		.	o	o	.	.	0	0	0	0	o	.	o	.	.	.				
DX 4-Wire M-lead to T2, E-lead to T1																				
Norway		.	.	o	.	o	0	0	0	0	.		<input type="checkbox"/>	<input type="checkbox"/>	<input type="checkbox"/>	<input type="checkbox"/>				
British Post Office		0	0	0	.	.	0	0	0	0	.	o	.	o	.	.				
DX 4-Wire																				
Conductor loop < 2.5 kΩ		.																	.	
Conductor loop > 2.5 kΩ		.																	.	
Carrier Failure alarm Enabled																				
Carrier Failure Alarm Disabled																				
Note: Set all positions in S7 (637) to OFF.																				

Table 2-35

QPC414 dual network

Application	Pin connection J3/S2 J4/S1
Option A:	
In-House RPE, Microwave, Fiberoptics	2 to 3
Option B:	
T-I Facilities, Channel Service Unit	1 to 2
<p>Note 1: Place the removable jumper plug over the pin configuration stated above. Select option B when connecting 1.5 MBit RPE to T-I through Channel Service Unit. For 2.0 MBit RPE, jumper settings should be off.</p> <p>Note 2: Option Jumper Locations (QPC414A vintage). These packs do not have the option selection and can only be used in the option A setting.</p> <p style="padding-left: 40px;">J3 option plug locations: H5 or E1 1</p> <p style="padding-left: 40px;">J4 option plug locations: H 17 or E7</p> <p style="padding-left: 40px;">S1 and S2 option location: E33</p> <p>Note 3: Option Jumper Locations (for different styles/series):</p> <p style="padding-left: 40px;">J3 option plug locations: E1 1 or Hi 1</p> <p style="padding-left: 40px;">J4 option plug locations: H17 or E7</p> <p style="padding-left: 40px;">S1 and S2 option location: E33</p> <p>Note 4: Connectors and Loop Relations:</p> <p>Even loop: J1 (faceplate network connector), J4 (option), S1 (option)</p> <p>Odd loop: J2 (faceplate network connector), J3 (option), S2 (option)</p>	

QPC417 Junctor Board

All unused **connectors** must be terminated with **QPF36A** Junctor Terminating Plugs. Any group not **used** requires four of these plugs.

Table 2-36
QPC423 192K RAM

Memory configuration			
Application	Pages	Range	F11 switch
			1 2 3 4 5 6 7 6
Single memory pack	0	0-32K	○ ● ○ ● ○ ○ ○ ●
	1	0-64K	
	2	32-64K	
	5	0-64K	
Dual memory pack Module 0	0	0-32K	● ● ○ ○ ○ ○ ○ ●
	1	0-64K	
	2	32-64K	
Module 1	5	0-64K	● ● ○ ● ○ ○ ○ ●
	6	0-64K	

Note: Module 1 can be either a QPC423 RAM or a QPC478 RAM.

Table 2-37
QPC425 CPU and SDI

Device witch	SDI address selection				Device number	AI switch				Speed Baud rate	Speed selection						Output device Plug location	
	AI switch					AI switch					AI switch							
	1	2	3	4		1	2	3	4		5	6	7	8	9	10		
0	●	●	●	●	8	●	●	●	○									Modem A7
1	○	●	●	●	9	○	●	●	○	300	○	○	●	○	●	○		
2	●	○	●	●	10	●	○	●	○	600	○	●	○	●	●	○		
3	○	○	●	●	11	○	○	●	○	1200	●	□	☞	☞	☞	☞	□	
4	○	●	○	●	12	○	●	○	○	1800	○	●	●	●	●	○		EIA data A 5 terminal
5	●	●	○	●	13	●	●	○	○	2400	○	○	●	○	○	●		
6	●	○	○	●	14	●	○	○	○	4800	☞	☞	☞	☞	☞	☞		
7	○	○	○	●	15	○	○	○	○	9600	☞	☞	☞	☞	☞	☞		

Note: Switch 9 and 10 and baud rates 2400 and up are available on QPC425D.

Table **2-38**
QPC426 192K RAM

Application	Memory configuration		F11 switch							
	Pages	Range	1	2.3	4	5	6	7	8	
SL-1 N, XN	0	0-64K	0	0	0	0	0	0	0	
	1	0-64K								
	2	0-64K								
SL-1 N, XN	4	0-64K	○	○	○	●	○	○	○	
	5	0-64K								
	6	0-64K								
SL-1 XN	8	0-64K	○	○	●	○	○	○	○	
	9	0-64K								
	10	0-64K								
SL-1 XN	12	0-64K	○	○	●	●	○	○	○	
	13	0-64K								
	14	0-64K								

Table **2-39**
QPC432 Four Port Data Line Card

	Jumper plugs			
	B6	B10	B24	B27-
Inside PVC (24 AWG)	E1-E2	E4-E5	E7-E8	E10-E11
Outside PIC (22 AWG)				
Inside PVC (26 AWG)	E2-E3	E5-E6	E8-E9	E11-E12
Outside PIC (24 and 26 AWG)				

Table 2-40
QPC441 3-Port Extender

Meridian SL-1	D20 switch				Shelf	Shelf and group Group	D20 switch			
	1	2	3	4			5	6	7	8
LE 1/2 Group	0	0	.	0	0	0
LE Full Group	0	0	.	0		1	.	●	○	●
VLE/XL, XN (QCA97)	0	0	.	.		2	●	□	☞	☞
XN, XT, N, NT, RT (See note)	0	.	0	.		3	●	○	○	●
	0	0	.	0		4	☐	☞	☞	☞
					1	0	☞	●	●	○
						1	☞	●	○	○
						2	☞	□	●	○
						3	☞	☐	☐	☐
						4	☐	☞	☐	☐

Note 1: If clock controllers are installed in an N, NT or RT, switch position 2 must also be in the ON position.

Note 2: ST = System option 21. NT = System option 51.61. XT = System option 71.

Table 2-41
QPC446/447 Conference

Options	Strap bcabtn
Enable Warning Tone — Insert strap from E8 to ENB	A37
Disable Warning Tone — Insert strap from E8 to DIS	A37
Low-Tone Level (30 dB below digital overload) — Insert strap from E7 to LOW	A37
High-Tone Level (24 dB below digital overload) — Insert strap from E7 to HIGH	A37

Table 2-42
QPC450/528 CO/FX/WATS

QPC450A, B, QPC528		Switch (location)							
		S1(A23)							
		0		1		2		3	
	Units Switch (location)	S2(E29)		S3(E9)		S4(A28)		S5(A10)	
		1	2	3	4	5	6	7	8
		•	•	•	•	•	•	•	•
Loop Start		•	•	•	•	•	•	•	•
(Ground Start		•	•	•	•	•	•	•	•
IMetering:									
Second Pair (M, MM)						0	0		
Third Wire, Battery on M						0	.		
Third Wire, Ground on M						•	0		
Jumpers	Units (Location)	0(E27)		1(E11)		2(D29)		3(D9)	
(for above)									
600R Resistive Impedance		Pin 1 to 2							
3-Component Complex Impedance		Pin 2 to 3							
									--
QPC450C		0		1		2		3	
	Units Switch (location)	S2(E29)		S3(E9)		S4(A28)		S5(A10)	
		1	2	3	4	5	6	7	8
Loop Start		•	•	•	•	•			•
(Ground Start		•	•	•	•	•			•
IMetering:									
Second Pair (M, MM)						0	0		
Third Wire, Battery on M						0	.		
Third Wire, Ground on M						.	0		

— continued —

Table 2-42
QPC450/528 CO/FX/WATS (continued)

QPC450C1, D	Units		0		1		2		3			
	Switch	(location)	S4(F28)		S3(F10)		S1(C27)		S2(B10)			
					1	2	3	4	5	6	7	8
Loop Start					0	.	0		o	o	.	
Ground Start					0	.	.		.	o	.	
Metering:												
Second Pair (M, MM)								0	0			
Third Wire, Battery on M								0	.			
Third Wire, Ground on M								.	0			
QPC450E, F	Units		0		1		2		3			
	Switch	(location)	S4(F25)		S3(F11)		S1(B25)		S2(B13)			
					1	2	3	4				
Loop Start					0	0						
Ground Start					.	.						
Metering:												
Second Pair (M, MM)								0	0			
Third Wire, Battery on M								0	.			
Third Wire, Ground on M								.	.			
Illustrated DIP switch settings:								Unit 1				
		ON		(Closed)				.				
		OFF		(Open)				o				
QPC450G	Units		0		1		2		3			
	Switch	(location)	S4(F25)		S3(F11)		S1(B25)		S2(B13)			
					1	2	3	4	5	6		
Loop Start					0	0						
Ground Start					.	.						
Short Loops (600 ohm Compromise Impedance Network)									.	0		
Long Loop (EIA Recommended Impedance Network)									0	.		

Table 2-43

QPC464 Peripheral Buffer

Ringing voltage	D13 or B12 switch					
	1	2	3	4	5	6
16 Hz, 86 Vrms superimposed on -48 V	.	0	0	0	0	0
20 Hz, 86 Vrms superimposed on -48 V	0	.	0	0	0	0
25 Hz, 75 Vrms superimposed on 48 V	0	0	.	0	0	0
50 Hz, 70 Vrms superimposed on -48 V	0	0	0	0	0	0
Dual Density Loops						0
Quad Density Loops						.

Table 2-44

QPC471 Clock Controller option settings

Clock controller	Switch	XN, XT	MERIDIAN SL-1 type		
			N, NT, RT	MS, SN	ST
QPC471A	SW2	Off	ON	not applicable	ON
QPC471B, C	SW1	OFF	ON	ON	ON--
	SW2	OFF	OFF	ON	OFF
	Jumper plug (F38)	TP8-TP9	TP8-TP9	TP9-TP10	TP8-TP9
	Jumper plug (G38)	TP11-TP12	TP11-TP12	TP12-TP13	TP11-TP12

Note: ON in switch setting means closed. OFF in switch setting means open.

Table 2-45
QPC472 Digital Trunk Interface Transmission Equalization

Switch setting	DTI to repeated facility (feet)	DTI to repeatered facility (meters)	DTI to cross-connect point (feet)	DTI to cross-connect point (meters)
5 ON	0-150	0-45	0-55	0-15
2, 4, 6 ON	150-450	45-135	56-355	15-100
1, 3, 7 ON	451 - 750	135-225	356-655	100 -200

Note: All switch positions **should** be OFF, except those shown under the SWITCH SETTING column.

Table 2-46
QPC479 128K RAM

Application	Pages	Memory configuration Range	F11 switch								
			1	2	3	4	5	6	7	8	
SL-1 LE, N	0	0-64K	•	0	0	0	0	0	0	0	•
	1	0-64K									
SL-1 LE, N	5	0-64K	•	0	•	0	0	0	0	0	•
	6	0-64K									
SL-1 LE, N	2	0-64K	•	0	•	•	0	0	0	0	•
	6	0-64K									
SL-1 LE, N	0	0-32K	•	0	0	•	0	0	0	0	•
	1	0-32K									
	2	0-64K									

Table 2-47
QPC503 CE Backplane

Application	Pin connections		
	P1	P5	P6
Main CE shelf without remote CE shelf	1-8	1-8	1-8
	3-6	3-6	4-5
Main CE shelf with remote CE shelf	1-8	2-7	1-8
	4-5	4-5	4-5
Remote CE shelf	1-8	2-7	1-8
	3-6	4-5	4-5

Note 1: The option plugs P1, P5 and P6 are 8-pin sockets. To set the required option, connect the pins indicated with the metal straps provided.

Note 2: Option plugs P2, P3 and P4 are set during manufacture and remain unchanged.

Table 2-48
QPC513 Enhanced Serial Data Interface

Program socket selection			Address selection Switch S2								
Option	Port	Socket number	Device number	Style A				Style B			
				1	2	3	4	1	2	3	4
DTE	1	UA10 UA12	0-1	○	○	○	*	○	○	○	*
	2	UA17 UA19	2-3	●	○	○	*	○	○	●	*
DTC	2	UA9 UA11	4-5	○	●	○	*	○	●	○	*
	2	UA16 UA18	6-7	●	●	○	*	○	●	●	*
RS-232-C Interface	1	UB9 UB11	8-9	○	○	●	*	●	○	○	*
	2	UB16 UB18	10-11	●	○	●	*	●	○	●	*
High-Speed Interface	1	UB10 UB12	12-13	○	●	●	*	●	●	○	*
	2	UB17 UB19	14-15	●	●	●	*	●	●	●	*

* Address Selection position 4:
 ● (ON) defaults SYNCHRONOUS MODE
 ○ (OFF) defaults ASYNCHRONOUS MODE

2-40 Option switch settings

Table 249
QPC525/526/527 CO trunk

	Switches at E29/E9/A29/A1 1							
	Units 0/1/2/3							
	1	2	3	4	5	6	7	8
OR Outpulsing	.	0						0
Standard Outpulsing	0	.						0
Ground Start			.	.				0
Loop Start			0	0				0
Loop Start, Automatic Guard Detection			0	.				0
QPC524 not installed					.			0
QPC524 installed					0			0
Battery on M operation						0	0	0
Ground on M operation						0	0	0
Second Pair M&MM						0	0	0

Table 2-50
QPC550A/B DID trunk real/complex balance Impedance selection

Device location	Device designation	Switch number	Unit number	Impedance type	
				Real	Complex
F31	S4.0	1	0	.	0
F24	S4.1	1	1	.	0
F16	S4.2	1	2	.	0
F11	s4.3	1	3	.	0

Table 2-51
QPC550A 600/900 OHM impedance selection

Device location	Device designation	Unit number	Switch number								Impedance (Ohms)
			1	2	3	4	5	6	7	8	
G29(a)	S3.0	0	○	●	●	○	○	●	●	○	600 900
			●	○	○	●	●	○	○	●	
G29(b)	S3.1	1	○	●	●	○	○	●	●	○	600 900
			●	○	○	●	●	○	○	●	
G8(a)	S3.2	2	○	●	●	○	○	●	●	○	600 900
			●	○	○	●	●	○	○	●	
G8(b)	s3.3	3	●	○	○	●	●	○	○	600 900	

Table 2-52
QPC550A Software/hardware control for 2dB pad

Device location	Device designation	Unit number	Switch number	S/W	2dB pad control	
					H/W (pad in)	H/W (pad out)
F38	S1	0	1	0	0	●
			2	●	○	
			3	●	○	
			4	0	○	
F1	s2	0	1	○	○	●
			2	●	○	○
			3	●	○	○
			4	○	○	●

2-42 Option switch settings

Table 2-53
QPC550B Attenuation level control

Device location	Device designation	Unit number	Switch number								2dB option
			1	2	3	4	5	6	7	8	
D39	S2.0/1	0	ON
		1	0	0	0	0	0	0	0	0	OFF
D1	S2.2/3	2	ON
		3	0	0	0	0	0	0	0	0	OFF

Table 2-54
QPC550B hardware control for 2 dB Pad

Device location	Device designation	Unit number	Switch number	2dB pad control	
				H/W (pad in)	H/W (pad out)
F38	S1.0/1	1	1	.	□
			2	o	o
			3	o	o
			4	.	o
F1	s l . m	3	1	.	o
			2	o	o
			3	o	o
			4	.	o

Table 2-55
QPC551 Radio Paging Trunk

Signal duration on the 18-pair faceplate		S1 (F33)												
		1	2	3	4	5	6							
Binary value (.1second)		1	2	4	8	16	32							
<p>Note: This switch determines the length of time a signal stays on the 18-pair data bus. The time is set in binary to the nearest tenth second. For example, to keep data on the bus for 5 seconds the switch settings total 50 by dosing S1.2, S1.5 and S1.6.</p>														
Signal duration and pause time		S1 (F33)												
		1	2	3	4	5	6	7						
Binary value (.1second)		1	2	4	8	16	32	64						
<p>Note: This switch determines the time data must stay on the 18-pair data bus plus the pause time between the removal of data and the reappearance of subsequent data. The time is set in binary to the nearest tenth second. For example to keep data on the bus for 5 seconds and have a pause time of 3.2 seconds the switch settings should total 62 by closing S2.2, S2.5 and S2.7.</p>														
Address, timer, single or multiple paging														
Application				S3 (E2) S4 (F2)										
				Unit 0, Unit 1										
	1	2	Address	3	4	5	6	Address	3	4	5	6		
Paging			0	0	0	0	0	a	0	0	0	0		
Single	.		1	0	0	0	0	9		
Multiple	o		2	0	.	0	0	10	o	.	o	.		
			3	.	.	o	o	11	.	.	o	.		
			4	.		□	□	12	.	o	.	.		
Timer (Note)			5	.	.	.	o	13	.	o	.	.		
Enabled	.		6	o	.	.	o	14	0	.	.	.		
Disabled	o		7	.	.	.	o	15		
<p>Note: When enabled, this switch prevents a signal from being sent out from a paging unit until 5 seconds have elapsed since the beginning of the previous signal on that same unit.</p>														
						S5 (E38)			S6 (D1)					
						Unit 0			Unit 1					
						Impedance termination			1					
						Real			.					
						Complex			o					

Table 2-56
QPC574/595 Digitone Receiver

	Location	Connectbn
12 DTMF tones	E9	Center to E3
16 DTMF tones	E9	Center to E2

Table 2-57
QPC577/596 Digitone Receiver Daughterboard

16/1 2 tone options jumper	Connect P1 pins
16 tone (4 X 4)	1 and 2
12 tone (3 X 4)	2 and 3

Note: Indicate (by checking YES) **on** the faceplate of the **QPC659 Dual Peripheral Buffer** when a **DTR Daughterboard** is **installed**.

Table 2-58
QPC584 Mass Storage Interface

Vintages A • D MSI	Switch S3
	1 2 3 4 5 6
0	• ○ ○ ○ ○ ○
1	○ • ○ ○ ○ ○
2	○ ○ . ○ ○ ○
3	. . . ○ ○ ○
System with Winchester disk	
Winchester disk shipping mode	
Vintage E Option	Switch S3
	1 2 3 4 5 6 7 8
5^{1/4} Floppy drives only	○ ○ ○ ○ ○ ○ ○ ○
5^{1/4} Floppy drives with 5^{1/4} Winchester drive	○ ○ ○ . ○ ○ ○ ○
3^{1/2} Floppy drives only	• ○ ○ ○ • ○ ○ ○
3^{1/2} Floppy drives with 3^{1/2} Winchester drive	• ○ ○ • • ○ ○ ○
Winchester Disk shipping mode	○ ○ ○ ○ ○ . ○ ○

Table 2-59
PC650/651 Music trunk

Channel	Switch location	Switch settings			
		1	2	3	4
0	F31	X		X	
1	F31		X		X
2	F9	X		X	
3	F9		X		X
4	c31	X		X	
5	c31		X		X
6	C9	X		X	
7	C9		X		X

Legend: Set X to OFF if the impedance of announcement source is 2 or 4 Ohms.
Set X to ON if the impedance of the announcement source is 600 Ohms.

Table 2-60
PC659 Dual Loop Peripheral

Options	Switch settings							--	
	U25				u3	U9	U10		u14
± 10 V Monitor	1	2	3	4	(All)	(All)	(All)	(All)	(All)
• disables circuit	0								
• enables circuit	.								
Ringing Select	1	2	3	4					
• 20 Hz and 25 Hz	0								
• 50 Hz	.								
QUAD	1	2	3	4					
• for double density	0								
• for quad density	.								
Loop	1	2	3	4					
• dual	.				0	0	0	.	0
• single	0				•	.	•	0	•

2-46 Odion switch settings

Table 2-61
QPC672 512K memory

Application	Memory configuration		F11 switch							
	Pages	Range	1	2	3	4	5	6	7	8
SL-1 N, XN, LE, VLE. XL, N(QCA96) and XN(QCA97)	0	0-64K	0	0	.	0	0	0	0	~
	1	0-64K								
	2	8-64K								
	4	0-64K								
	5	0-64K								
	6	0-64K								
	8	0-64K								
	9	0-64K								

Note: Switch 8 must be in off position for Non-CE Mod shelf.

Table 262
QPC673 512K memory (with error correction)

Application	Memory configuration		F11 switch							
	Pages	Range	1	2	3	4	5	6	7	8
SL-1 MS, s, ST	0	0-64K	0	0	.	0	0	0	0	.
	1	0-64K								--
	2	8-64K								
	4	0-64K								
	5	0-64K								
	6	0-64K								
	8	0-64K								
	9	0-64K								

Note: Switch 8 must be in off position for Non-CE Mod shelf.

Table 263
QPC674 256K memory with error correction

Application	Memory configuration			F11 switch							
	Pages	Range		1	2	3	4	5	6	7	8
SL-1 MS, s	0	0-32K		0	0	0	0	0	0	0	0
	1	0-64K									
	2	32-64K									
	5	0-64K									
	6	0-64K									

Note 1: This pack responds to both module 0 and module 1 in existing software.
Note 2: No software change is required if configuration 128 128 was used.

Table 2-64
QPC687 CPU with SDI/RTC/ROM

Device Number	Address selection				Baud rate	Speed selection										Output device "	
	B1 switch					B1 switch (note)										QPC687A Port	Plug location
0	●	●	●	●	300	○	○	●	○	●	○		Modem	A7	--		
1	0	.	.	.	600	○	●	○	●	●	○						
2	●	□	☞	☞	1200	●	○	●	●	●	○						
3	0	0	.	.	1800	○	●	●	●	●	○		EIA data terminal	A5			
4	●	⊓	⊓	⊓	2400	○	○	●	○	○	●						
5	☐	☞	☐	☞	4800	0	.	0	.	0	.						
6	●	○	○	●	9600	●	○	●	●	○	●						
7	0	0	0	.									QPC687B Port	Switch location			
8	●	●	●	○													
9	○	●	●	○										A23	B23		
10	●	○	●	○										S1	s2		
11	0	0	.	0									Modem	All on	All off		
12	●	●	○	○													
13	0	.	0	0									EIA data terminal	All off	All on		
14	●	○	○	○													
15	0	0	0	0													

Note: In the QPC687B, the option plug has been replaced with two DIP switches (S1 and S2).

Table 2-65

QPC699 CE backplane

Application	Pin connections		
	P1	P5	P6
Network slot	1-8 3-6	1-8 3-6	1-8 4-5
Segmented Bus Extender — Main Shelf	1-8 4-5	2-7 4-5	1-8 4-5
Segmented Bus Extender — Remote Shelf	1-8 3-6 4-5	2-7 4-5	1-8

Note **1**: The option plugs **P1**, P5 and P6 are 8-pin **sockets**. To set the required option, connect the pins indicated with the metal straps **provided**.

Note 2: Option plugs P2, P3 and P4 are set during manufacture and remain unchanged.

Table 2-66
QPC720 Primary Rate Interface Transmission Equalization Switch

Note: Switch settings on the 2-pole SW1 (location A5) are all OFF. All switch positions for S2 (location B22) should be OFF except those shown under the SWITCH SETTING column. The 8-pole SW3 (location E37) switch positions should be set to OFF except as shown below for DTI with ESF.

Switch S2 settings	PRI to repeatered facility (feet)	PRI to repeatered facility (meters)	PRI to cross-connect point (feet)	PRI to cross-connect point (meters)
50N	O-150	0-45	O-100	0 - 30
2, 4, 6 ON	151 -450	46 - 135	101 - 355	31 - 100
1, 3, 7 ON	451 - 750	136-225	356 - 655	101 - 200

Switch 3 Options for DTI with ESF

SW3-1	ON = ESF (Extended Superframe format) OFF = SF (Superframe format)
SW3-2	ON = B8ZS Line Encoding (required for 64K clear option) OFF = AM1 Line Encoding
SW3-3	ON = FDL (Facility Data Link) Yellow Alarm Method (Cannot be used in Canada) OFF = Digit 2 Yellow Alarm Method

* For D2, D3 or D4 framing formats (Superframe formats), set all SW3 options to OFF.

Table 2-67
QPC742 Floppy disk interface

Vintages A - C		Switch SW3					
FDI		1	2	3	4	5	6
0		0	0	0	0	0	0
1		0	0	0	0	0	0
2		0	0	0	0	0	0
3		0	0	0	0	0	0

Vintage D		Switch SW3							
Option		1	2	3	4	5	6	7	8
5 ¹ / ₄ floppy drives only		0	0	0	0	0	0	0	0
3 ¹ / ₂ floppy drives only		0	0	0	0	0	0	0	0

Table 2-68
QPC757 D-channel interface card

Vintage A Program socket selection				Address selection				
Option	Port	Socket number		Device number	Switch S2			
					1	2	3	4
DTE	1	UA10	UA12	-0-1	0	0	0	0
	2	UA17	UA19	2-3	0	0	.	0
DCE	1	UA9	UA11	4-5	0	.	0	0
	2	UA16	UA18	6-7	o	.	.	o
M-232-C interface	1	UB9	UB11	a-9	.	o	o	o
	2	UB16	UB18	10-11	.	o	.	o
High-speed interface	1	UB10	UB12	12-13	.	.	o	o
	2	UB17	UB19	14-15

Vintage C Program socket selection				Address selection				
Option	Port	Socket number		Device number	Switch S2			
					1	2	3	4
DTE	1	U11	U9	0-1	0	0	0	0
	2	u5	u3	2-3	o	o	.	o
DCE	1	u12	U10	4-5	0	.	o	o
	2	U6	U4	6-7	□	□	.	□
W-232-C interface	1	u31	u29	a-9	.	o	o	o
	2	U25	U23	10-11	.	o	.	o
High-speed interface	1	U30	U28	12-13	.	.	o	o
	2	U24	U22	14-15

Table 2-69
QPC775 clock controller

	SW2				SW3				SW4			
	1	2	3	4	1	2	3	4	1	2	3	4
XN, XT	0	0	0	0	o	o	o	o	.	.		
N, NT, RT, ST	0	0	0	0	.	.		
MS, SN	0	0		

Table 2-70
QPC72M loop signaling

Application	Single density port 0/1 E27/E11					
	1	2	3	4	5	6
Outgoing ANI only:						
Loop pulsing	0	0	0	0	0	0
Battery and ground pulsing	0	0	0	0	.	0
Other than outgoing ANI	•	□	□	□	□	□

Table 2-71
QMT8 SADM

Switch 1		set to zeroes (no VFDN)
Switch 3	1	not used
	2	not used
	3	FDX (full duplex)
	4	modem
	5	internal dock
	6	no echo
	7	auto answer
	8	off (no loopback)
Switch 4	1	on
	2	on (hot line')
	3	off (DTR-data terminal ready required)
	4	on (synchronous) U5 and U7 must be jumped

• Only one side of the interface should be set to originate the hot line.

Table 2-72

QMT11 ASIM

Hot Line	ON
Forced DTR	ON
FDX (full duplex)	ON
SYNC	ON
INTERNAL CLK	ON
Modem/Network	Modem
Auto Answer	ON
Loopback	OFF

Note 1: Only one side of the interface should be set to originate the hot line.

Note 2: Forced data Terminal ready (DTR) will automatically reinitiate a dropped hot line call.

Table 2-73

QPC720 Transmission Equalization

SW2 switch settings	To repeated facility		To cross-connect point	
	feet	meters	feet	meters
DTI	0-150 151 -450 451 - 750	0-45 46 - 135 136-225	0 - 55 56 - 355 356 - 655	0- 15 16-100 101-200
PRI 5 ON 2, 4, 6 ON 1, 3, 7 ON	same	same	0-100 101 - 355 356 - 655	0 - 30 31 - 100 101 - 200

Table 2-74
IPC841 QSDI Port 1 and 2 address selection

Port	Device number		SW 14 setting								
	1	Port2	1	2	3	4	5	6	7	8	
0		1	0	0	0	0	0	0	•	•	•
2		3	0	0	0	0	0	0	•	•	0
4		5	0	0	0	0	0	0	•	0	•
6		7	0	0	0	0	0	0	.	0	0
8		9	0	0	0	0	0	0	0	•	•
10		11	0	0	0	0	0	0	0	.	0
12		13	0	0	0	0	0	0	0	0	.
14		15	0	0	0	0	0	0	0	0	0

Note 1: Switch SW16, position 1, 2, 3 and 4 must all be OFF.
 Note 2: To avoid address conflicts, SW 14 and SW1 5 can never have identical setting.
 Note 3: To disable ports 1 and 2, set SW15, position 1 to ON.

Table 2-75
IPC841 QSDI Port 3 and 4 address selection

Port	Device number		SW 15 setting								
	3	Port 4	1	2	3	4	5	6	7	8	
0		1	0	0	0	0	0	0	•	•	•
2		3	0	0	0	0	0	0	.	~	0
4		5	0	0	0	0	0	0	.	0	.
6		7	0	0	0	0	0	0	.	0	0
8		9	0	0	0	0	0	0	0	•	•
10		11	0	0	0	0	0	0	0	.	0
12		13	0	0	0	0	0	0	0	0	.
14		15	0	0	0	0	0	0	0	0	0

Note 1: Switch SW16, position 1, 2, 3 and 4 must all be OFF.
Note 2: To avoid address conflicts, SW14 and SW1 5 can never have identical setting.
Note 3: To disable port 3 and 4, set SW15, position 1 to ON.

Table 2-76
QPC841 QSDI Port baud rate switch settings

Data Rate (BAUD)	Port1 SW1 0				Port2 SW1 1				Port3 SW1 2				Port4 SW1 3			
	1	2	3	4	1	2	3	4	1	2	3	4	1	2	3	4
150	0	0	.	.	0	0	.	.	0	0	.	.	0	0	.	.
300	0	.	0	.	0	.	0	.	0	.	0	.	0	.	0	.
600	0	0	0	.	0	0	0	.	0	0	0	.	0	0	0	.
1200	☐	☐	●	☐	○	●	●	○	○	●	●	○	○	●	●	○
2400	○	○	●	○	0	0	.	0	0	0	.	0	○	○	●	○
4600	○	●	○	○	0	.	0	0	0	.	0	0	0	.	0	0
9600	0	0	0	0	0	0	0	0	0	0	0	0	0	0	0	0

Table 2-77
QPC841 QSDI Port DTE/DCE mode selection

Port 1		SW8 setting						SW9 setting					
	Mode	1	2	3	4	5	6	1	2	3	4	5	6
	DTE (terminal)	0	0	0	0	0	0
	DCE (modem)	0	0	0	0	0	0
Port 2		SW6 setting						SW7 setting					
	Mode	1	2	3	4	5	6	1	2	3	4	5	6
	DTE (terminal)
	DCE (modem)
Port 3		SW4 setting						SW5 setting					
	Mode	1	2	3	4	5	6	1	2	3	4	5	6
	DTE (terminal)	0	0	0	0	0	0
	DCE (modem)	0	0	0	0	0	0
Port 4		SW2 setting						SW3 setting					
	Mode	1	2	3	4	5	6	1	2	3	4	5	6
	DTE (terminal)	*	0	0	0	0	0	0
	DCE (modem)	○	○	○	○	○	○	.	●	●	●	.	.

Table 2-78
NT7D03AA Ringing Generator DC

Frequency Hz	Volts RMS	Switch S300			
		1	2	3	4
20	86	0	0	0	*
20	80	.	0	0	*
25	86	0	•	0	*
25	80	.	•	0	*
25	70	0	0	.	*
50	86	.	0	.	*
50	80	0	.	.	*
50	70	.	.	.	*

* = do not care

Table 2-79
NT7D04AA Common/Peripheral Power Supply DC

Note: To access these switches, you must remove the daughterboard from the chassis.

Frequency Hz	Volts RMS	Switch S300			
		1	2	3	4
20	86	○	○	○	*
20	80	●	○	○	*
25	86	○	●	○	*
25	80	●	●	○	*
25	70	○	○	●	*
50	86	●	○	●	*
50	80	○	●	●	*
50	70	●	●	●	*

* = do not care



NT8D14AA Universal Trunk Card

The Universal **Trunk** card provides eight analog trunks which can function as COT, Loop, Paging and RAN trunks. Select the DID loop length by setting the jumper straps as illustrated in Table 2-80.

Table 2-80
NT8D14AA Universal Trunk

Modes	Location	Jumper strap
Central Office (CO)	J1, J2	OFF
2-way tie trunk (Loop Dial Repeat)	J1, J2	OFF
2-way tie trunk (Outgoing/incoming Dial)	J1, J 2	OFF
Recorded Announcement (PAN)	J1, J2	OFF
Paging Trunk	J1, J2	OFF
Japan CO/DID operation	J1, J2	OFF
DID operation loop length \geq 2000 ohms	J1, J2	ON
DID operation loop length $<$ 2000 ohms	J1, J2	OFF
<p>Note 1: OFF = no strap present.</p> <p>Note 2: Locations (J1, J2) apply to all eight units.</p>		

NT8D15AA E & M Trunk Card

The Extended E & M Trunk card provides four trunks which can function a **2W E & M, 4W E & M, and Paging.**

Select the trunk type desired by setting the jumper straps as illustrated in Figure 2-81.

Table 2-81
NT8D15AA E & M Trunk Card Jumper settings

Mode of operation	J2	J9
4W — Type I	ON	connect pins 2 - 3
4W — Type II	ON	connect pins 2 - 3
2W — Type I	ON	connect pins 2 - 3
Paging Trunk	ON	connect pins 2 - 3

NT8D17AA Conference/TDS settings

The Conference/TDS card provides conferencing ability for A law or MU law operation, and generates the tones, cadences, and bursts for the SL- 1. These settings are only used when the customer is required to select the constant attenuation pad levels. The **Conference/TDS Card** can provide 8 levels of attenuation.

Select the desired attenuation level by setting Switch 2, positions **1, 2,** and **3** as illustrated in Table 2-82.

Note: The **J1** connector on the faceplate is reserved for future use.

Table 2-82
NT8D17AA Conference/TDS settings — SW2

Attenuation levels	Position		
	1	2	3
12.2 db	.	●	●
10.4 db	.	●	0
8.2 db	0	.	.
7.2 db	0	.	0
5.4 db	.	0	.
4.0 db	.	0	0
1.2 db	0	0	.
0 db	0	0	0

Note: Set Switch position 4 to ON to disable warning tone option. When the Naming tone is enabled, see Table 2-83 to select warning tone level.

Level	Setting
24 db	J2 pins 2, 3
30 db	J2 pins 1, 2

Table 2-84
NT8D21AA Ringing Generator AC

Frequency Amplitude		Settings		
Hz	V ac	P1	P2	P3
20	86	open	-open	2-5 8-11
25	70	open	1 - 4 7-10	open
25	80	open	3-6 9-12	open
25	86	open	2-5 8-11	open
50	70	1 - 4 7-10	open	open
50	80	3-6 9 - 12	open	open ..

NT8D22AB System Monitor option settings

The System Power Monitor is used to monitor system and individual UEM power and thermal status. The Master (normally located in the stack containing CPU 0) is numbered 0, and its slave-s are numbered from 1 - 63.

Table 2-85
NT8D22AB System Monitor SW1

SW1 function	Position							
	1	2	3	4	5	6	7	8
For hybrid systems	•							
For SL-1 System Option 21, 51, 61, and 71	○							
If position 1 is OFF set to OFF		○						
If position 1 is ON and all columns are PE set to OFF		○						
If position 1 is ON and Master column contains CPU, set master to ON and all slaves to OFF								
Master		•					--	
Slaves		○						
For DC power system			•					
For AC power system			○					
PFTU activated by this column when over-temperature.				•				
PFTU cannot be activated by this column when over- temperature.				○			--	
For operation with an NT or XT hybrid system, or when position 1 is OFF					○			
For operation with an ST or RT hybrid system.					•			
For operation with an NT or XT hybrid system, or when position 1 is OFF						○		
For operation with an ST or RT hybrid system.						•		
For hybrid NT or XT with all PE columns (CPU is in existing NT or XT).							○	0
For any hybrid system with CE and PE columns (CPU is in System option 21, 51, 61, 71 column)							0	•
For hybrid ST or RT with all PE columns (CPU is in existing ST or RT)							•	•
For operation with System option 21, 51, 61, and 71 only							0	0
	1	2	3	4	5	6	7	8

Table 2-86
NT8D22AB System Monitor SW2

SW2 Indication	Position							
	1	2	3	4	5	6	7	8
Master System Monitor	.							
Slave System Monitor	0							
This switch currently not used (set to OFF).			0					
On Master, indicates total number of slaves								Set positions 3 - 8 according to Table 2-88 for the number of slaves.
On each slave, indicates the slave address								Set positions 3 - 8 according to Table 2-89 for address settings.)

Table 2-87
NT8D22AB System Monitor SW3

SW3 indication		Position			
		1	2	3	4
CTA	ON for Master	.			
	OFF for Slaves	0			
CTR	ON for Master		.		
	OFF for Slaves		0		
FAIL	ON for Master			.	
	OFF for Slaves			0	
MAJOR	ON for Master				0
	OFF for Slaves				0

Table 2-88
NT8D22AB Settings for total number of slave **System Monitors (SW2 on Master)**

# of Slave units	Switch position						# of Slave units	Switch position					
	3	4	5	6	7	8		3	4	5	6	7	8
0	•	•	•	•	•	•	32	○	•	•	•	•	•
1	•	•	•	•	•	○	33	○	•	•	•	•	○
2	•	•	•	•	○	•	34	○	•	•	•	○	•
3	•	•	•	•	○	○	35	○	•	•	•	○	○
4	•	•	•	○	•	•	36	○	•	○	○	•	•
5	•	•	•	○	•	○	37	○	•	•	○	•	○
6	•	•	•	○	○	•	38	○	•	○	○	○	•
7	•	•	•	○	○	○	39	○	•	•	○	○	○
8	•	•	○	•	•	•	40	○	•	○	•	•	•
9	•	•	□	•	☞	□	41	○	•	○	•	•	○
10	•	•	○	•	○	•	42	○	•	○	•	○	•
11	•	•	○	•	○	○	43	○	•	○	•	○	○
12	•	•	○	○	•	•	44	○	•	○	○	•	•
13	•	•	○	○	•	○	45	○	•	○	○	•	○
14	•	•	○	○	○	•	46	○	•	○	○	○	•
15	s	s	○	○	○	○	47	○	•	○	○	○	○
16	•	○	•	•	•	•	48	○	○	•	•	•	•
17	•	○	•	•	•	○	49	○	○	•	•	•	○
18	•	○	•	•	○	•	50	○	○	•	•	○	•
19	•	○	•	•	○	○	51	○	○	•	•	○	○
20	•	□	☒	□	☞	☞	52	□	☒	☞	☒	☞	☞
21	•	○	•	○	•	○	53	○	○	•	○	~	○
22	•	○	•	○	○	•	54	○	○	•	○	○	•
23	•	○	•	○	○	○	55	○	○	•	○	○	○
24	•	○	○	•	•	•	56	○	○	○	•	c	•
25	•	○	○	•	•	○	57	○	○	○	•	•	○
26	•	○	○	•	○	•	58	○	○	○	•	○	•
27	•	○	○	•	○	○	59	○	○	○	•	○	○
28	•	○	○	○	•	•	60	○	○	○	○	•	•
29	e	○	○	○	•	○	61	○	○	○	○	•	○
30	•	○	○	○	○	•	62	○	○	○	○	○	•
31	•	○	○	○	○	○	63	○	○	○	○	○	○

Table 2-89
NT8D22AB Slave System **Monitor** addresses (SW 2)

Slave Address	Switch Position						slave Address	Switch Position						
	3	4	5	6	7	8		3	4	5	6	7	8	
1	.	.	.	•	•	○	33	○	•	.	•	•	•	C
2	.	•	.	.	0	•	34	○	•	•	•	•	○	•
3	•	•	35	○	•	•	•	•	○	C
4	.	•	•	○	•	•	36	○	•	•	○	•	•	•
5	.	•	•	○	•	○	37	○	•	•	○	•	•	C
6	.	•	•	○	○	•	38	○	•	•	○	○	•	•
7	0	.	0	0	0	0	39	○	•	•	○	○	○	C
8	•	•	○	•	•	•	40	○	•	○	•	•	•	•
9	•	•	○	•	•	○	41	○	•	○	•	•	•	C
10	.	.	0	.	0	.	42	○	•	○	•	○	•	•
11	•	•	○	•	○	○	43	○	•	○	•	○	○	C
12	•	•	○	○	•	•	44	○	•	○	○	•	•	•
13	•	•	○	○	•	○	45	○	•	○	○	•	•	C
14	•	•	○	○	○	•	46	○	•	○	○	○	•	•
15	•	•	○	○	○	○	47	○	•	○	○	○	○	C
16	.	0	48	○	○	•	•	•	•	•
17	•	○	•	•	•	○	49	○	○	•	•	•	•	C
18	•	○	•	•	○	•	50	○	○	•	•	○	•	•
19	•	○	•	•	○	○	51	○	○	•	•	○	○	C
20	•	○	•	○	•	•	52	○	○	•	○	•	•	•
21	•	○	•	○	•	○	53	○	○	•	○	•	•	C
22	•	○	•	○	○	•	54	○	○	•	○	○	•	•
23	•	○	•	○	○	○	55	○	○	•	○	○	○	C
24	•	○	○	•	•	•	56	○	○	○	•	•	•	•
25	•	○	○	•	•	○	57	○	○	○	•	•	•	C
26	0	0	0	.	0	.	58	○	○	○	•	○	•	•
27	0	0	0	.	0	0	59	○	○	○	•	○	○	C
28	0	0	0	0	.	.	60	○	○	○	○	•	•	•
29	0	0	0	0	.	0	61	○	○	○	○	•	•	C
30	•	○	○	○	○	•	62	○	○	○	○	○	•	•
31	•	○	○	○	○	○	63	○	○	○	○	○	○	C
32	0								

NT8D41 AA Serial Data Interface paddle board

Table 2-90

NT8D41AA Port 1 and 2 address selection switch settings

Device number		SW 4 setting				
Port 1	Port2	Pos	4	2	3	4
0	1	0
2	3	0	•	•	•	0
4	5	0	•	0	•	•
6	7	0	.	0	0	0
8	9	0	0	.	.	.
10	11	0	0	•	•	0
12	13	0	0	0	.	.
14	15	0	0	0	0	0

Table 2-91

NT8D41AA Port baud rate switch settings

Data Rate (BAUD)	Port 1 SW2				Port 2 SW3					
	Pos	1	2	3	4	Pos	1	2	3	4
150	0	0	.	.	.	0	0	.	.	.
300	0	.	0	.	.	0	•	0	•	•
600	0	0	0	.	.	0	0	0	0	0
1200	0	.	0	0	0	0	.	0	0	0
2400	0	0	.	0	0	0	0	.	0	0
4800	0	.	0	0	0	0	.	0	0	0
9600	0	0	0	0	0	0	0	0	0	0

2-66 Option switch settings

Table 2-92

NT8D41AA Port DTE/DCE mode selection switch settings

Port 1	Mode	SW5						SW6					
		1	2	3	4	5	6	1	2	3	4	5	6
	DTE (I-T-Y)	0	0	0	0	0	0
	DCE (Modem)	0	0	0	0	0	0	•	0	•	•	•	•
Port 2	Mode	SW7						SW8					
		1	2	3	4	5	6	1	2	3	4	5	6
	DTE (TTY)	0	0	0	0	0	0
	DCE (Modem)	0	0	0	0	0	0	•					

Circuit pack application examples

SL-1 system option 21 and ST switch settings

There are three typical configurations for these SL-1 systems:

- System option 21
- ST with PE upgrade
- ST with CE upgrade to system option 21

The following pages contain typical switch **settings** for these SL-1 Systems.

System option 21

The Master System Monitor is installed in the column containing the CPU. All others **are** slaves (one slave per column).

Table 3-1
Master switch settings

Switch	Position							
	1	2	3	4	5	6	7	8
SW 1	0	0	*	.	0	0	0	0
SW2	.	o	(see Table 2-88 to set positions 3 - 8)					
SW 3				

Legend: * Set to ON for DC system, OFF for AC system

Table 3-2
Slave switch settings

Switch	Positiin							
	1	2	3	4	5	6	7	8
SW 1	0	0	*	**	0	o	0	0
SW 2	0	0	(see Table 2-89 to set positions 3 - 8)					
SW 3	0	0	0	o				

Legend: * Set to ON for DC system, OFF for AC system
** Set to ON to **enable** Power Fail Transfer Unit
Set to OFF to disable Power Fail Transfer Unit

ST with PE upgrade

Table 3-3
Master **switch** settings

Switch	Position							
	1	2	3	4	5	6	7	8
SW 1	.	0	*	**
SW 2	.	0	(see Table 2-88 to set positions 3 • 8)					
SW 3

Legend:

- * Set to ON for DC system. OFF for AC system
- ** Set to ON to enable Power Fail Transfer Unit
- Set to OFF to disable Power Fail Transfer Unit

Table 3-4
Slave **switch** settings

Switch	Position							
	1	2	3	4	5	6	7	8
SW 1	.	0	*	**
SW 2	0	0	(see Table 2-89 to set positions 3 • 8)					
SW 3	0	0	0	0

Legend:

- * Set to ON for DC system, OFF for AC system
- ** Set to ON to enable Power Fail Transfer Unit
- Set to OFF to disable Power **Fail** Transfer Unit

ST with CE upgrade to system option- 21

Table 3-5
Master switch settings

Switch	Position							
	1	2	3	4	5	6	7	8
SW1	.	.	*	.	.	.	o	.
SW 2	.	o	(see Table 2-88 to set positions 3 - 8)					
SW 3				

Legend: * Set to ON for DC system, OFF for AC system

Table 3-6
Slave switch settings

Switch	Position								"
	1	2	3	4	5	6	7	8	
SW1	.	0	*	**	.	.	0	.	
SW 2	0	0	(see Table 2-89 to set positions 3 - 8)						
SW 3	0	0	0	0					

Legend: * Set to ON for DC **system**, OFF for AC system
 ** Set to ON to enable Power Fail Transfer Unit
 Set to OFF to disable Power Fail Transfer Unit

SL-1 system option 51, 61 and NT switch settings

There are three typical configurations for these SL- 1 systems:

- System options **51, 61**
- NT with PE upgrade
- NT with CE upgrade to system option 5 1.6 1

The following pages contain typical switch settings for these SL-1 systems.

System option 51, 61

Table 3-7
Master switch settings

Switch	Position								
	1	2	3	4	5	6	7	8	
SW1	o	0	*	.	0	0	0	o	
SW 2	.	o	(see Table 2-88 to set positions 3 - 8)						
SW 3					

Legend: * **Set to ON for DC system, OFF for AC system**

Table 3-8
Slave switch settings

Switch	Position								
	1	2	3	4	5	6	7	8	
SW1	0	0	*	**	0	0	0	o	
SW 2	0	0	(see Table 2-89 to set positions 3 - 8)						
SW 3	0	0	0	0					

Legend: * **Set to ON for DC system, OFF for AC system**
 ** Set to ON to enable Power Fail Transfer Unit
 Set to OFF to disable Power Fail Transfer Unit

NT with PE upgrade

Table 3-9
Master switch settings

Switch	Position							
	1	2	3	4	5	6	7	8
SW1	.	o	*	**	0	0	.	o
SW 2	.	o	(see Table 2-88 to set positions 3 - 8)					
SW 3				

Legend:

- * Set to ON for DC system, OFF for AC system
- ** Set to ON to **enable** Power Fail Transfer Unit
Set to OFF to disable Power Fail Transfer Unit

Table 3-10
Slave switch settings

Switch	Position							
	1	2	3	4	5	6	7	8
SW 1	.	o	*	**	0	0	.	o
SW 2	0	0	(see Table 2-89 to set positions 3 - 8)					
SW 3	0	0	0	0				

Legend:

- * Set to ON for DC system, OFF for AC system
- ** Set to ON to enable Power Fail Transfer Unit
Set to OFF to disable Power Fail Transfer Unit

NT with CE upgrade to system option 51, 61

Table 3-11

Master switch settings

Switch	Position							
	1	2	3	4	5	6	7	8
SW1	.	.	*	.	0	0	0	.
SW 2	.	0	(see Table 2-66 to set positions 3 • 8)					
SW 3				

Legend: * Set to ON for DC system, OFF for AC system

Table 3-12

Slave switch settings

Switch	Position							
	1	2	3	4	5	6	7	8
SW1	.	0	*	**	0	0	0	.
SW 2	0	0	(see Table 2-89 to set positions 3 • 8)					
SW 3	0	0	0	0				

Legend: * Set to ON for DC system, OFF for AC system
 ** Set to ON to enable Power Fail Transfer Unit
 Set to OFF to disable Power Fail Transfer Unit

SL-1 system option 71 and XT switch Settings

There are three typical configurations for these SL-1 systems:

- System options 7 1
- XT with PE upgrade
- XT with CE upgrade to system option 7 1

The following pages contain typical switch settings for these SL-1 systems.

System option 71

The Master System Monitor is **installed** in the column containing CPU0. A maximum of 63 slaves are used (one per column, including the column containing CPU1).

Table 3-13
Master switch settings

Switch	Position							
	1	2	3	4	5	6	7	8
SW1	0	0	*	**	0	0	0	0
SW 2	.	o	(see Table 2-88 to set positions 3 • 8)					
SW 3				

Legend:

- * Set to ON for DC system, OFF for AC system
- ** Set to ON to enable Power Fail Transfer Unit
- Set to OFF to disable Power **Fail** Transfer Unit

Table 3-14
Slave unit 1 switch settings (in column containing CPU1)

Switch	Position							
	1	2	3	4	5	6	7	8
SW1	0	0	*	**	0	0	0	0
SW 2	0	0	0
SW 3	o	o	o	o				

Legend:

- * Set to ON for DC system, OFF for AC system
- ** Set to ON to enable Power Fail Transfer Unit
Set to OFF to disable Power Fail Transfer Unit...

Table 3-15
Slave switch settings (all other slaves)

Switch	Position								
	1	2	3	4	5	6	7	8	
SW1	0	0	*	0	0	0	0	0	
SW 2	0	0	(see Table 2-89 to set positions 3 • 8)						
SW 3	0	0	0	0				--	

Legend:

- * Set to ON for DC system, OFF for AC system
- ** Set to ON to enable Power Fail Transfer Unit
Set to OFF to disable Power Fail Transfer Unit

XT with PE upgrade

Table 3-16
Master switch settings

Switch	Position							
	1	2	3	4	5	6	7	8
SW 1	.	0	*	**	0	.	.	.
SW 2	.	.	(see Table 2-88 to set positions 3 - 8)					
SW 3

Legend:

- * **Set** to ON for DC system, OFF for AC system
- ** Set to ON to enable Power Fail Transfer Unit
- Set to OFF to disable Power Fail Transfer Unit

Table 3-17
Slave switch settings

Switch	Position							
	1	2	3	4	5	6	7	8
SW1	.	0	*	**	0	0	.	.
SW 2	0	0	(see Table 86 to set positions 3 - 8)					
SW 3	0	0	0	0				

Legend:

- * **Set** to ON for DC system, OFF for AC system
- ** Set to ON to enable Power Fail Transfer Unit
- Set to OFF to disable Power Fail Transfer Unit

XT with CE upgrade to system option 71

Table 3-18
Master switch settings

Switch	Position								
	1	2	3	4	5	6	7	8	
SW 1	.	.	*	0	0	0	0	.	
SW 2	.	o	(see Table 2-88 to set positions 3 - 8)						
SW 3	•	•	•	•					

Legend: * Set to ON for DC system, OFF for AC system

Table 319
Slave unit 1 switch settings

SW 3	o	o	o	o				
-------------	---	---	---	---	--	--	--	--

Legend:
* Set to ON for DC system, OFF for AC system
** Set to ON to enable Power Fail Transfer Unit
Set to OFF to disable Power Fail Transfer Unit

Table 3-20
Slave switch settings (all other slaves)

Switch	Position							
	1	2	3	4	5	6	7	8
SW1	.	0	*	**	o	0	o	.
SW 2	0	0	(see Table 2-89 to set positions 3 - 8)					
SW 3	0	0	0	0				

Legend:

- * Set to ON for DC system, OFF for AC system
- ** Set to ON to **enable** Power Fail Transfer Unit
 Set to OFF to disable Power Fail Transfer Unit

1000000000



1000000000



SL-1

System options **21, 51, 61, 71**

Circuit pack installation and testing

Copyright © 1984 Northern Telecom
All rights reserved.
Information subject to change without notice.
Release 1.0
Standard
January, 29, 1990
Printed in U.S.A.

 northern
telecom

553-3001-215

SL-1

Telephone sets and attendant consoles

Installation procedures
Standard

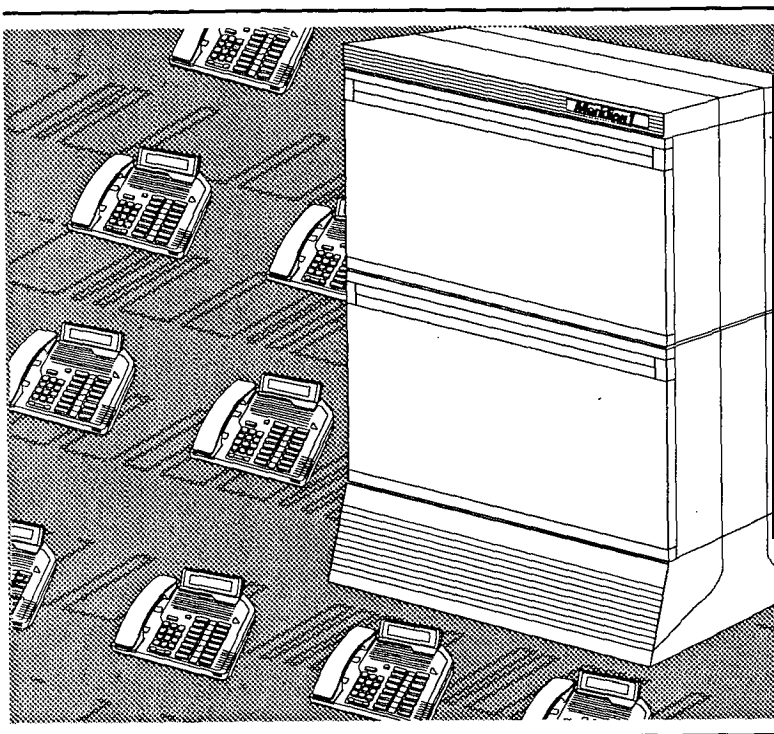

nt northern
telecom

Meridian 1
Communication Systems



1





SL-1

Telephone sets and attendant consoles

Installation procedures

Publication number: 553-3001-215

Document release: 1.0

Document status: Standard

Date: December 20, 1989



© 1984 Northern Telecom

All rights reserved.

Set and console installation 553-3001-215

Revision history

December 20, 1989

Standard issue. Revised to incorporate corrections and updated information.
Due to the extent of changes, change bars are omitted.

Contents

Introduction	1-1
<hr/>	
Wiring installation	2-1
Wiring for telephone sets and attendant consoles	2-1
Normal operating ranges	2-5
<hr/>	
Attendant consoles	3-1
Packing and unpacking	3-1
Installation and removal	3-1
Designating attendant consoles	3-1 2
Cross connecting attendant consoles	-3-18
<hr/>	
Telephone sets	4-1
Packing and unpacking	4-1
Installation and removal	4-1
Designating telephone sets	4-16
Connecting telephone sets	4-1 8
Cross-connecting telephone sets	4-22
<hr/>	
Add-on modules	5-1
Packing and unpacking	5-1
QMT1 , QMT2 add-on module	5-1
Faceplate	5-2
Designating add-on modules	5-11
QMT3 Lamp Field Array	5-1 2
Busy Lamp Field/Console Graphics Module	5-20
QMT4, QMT15 handset modules	5-33
Amplified handset on SL-1 telephone sets	5-44

NE-G6QDC amplified handset on SL-1 telephone sets	5-46
QKK1 , QKK3 Handsfree unit interface kit	5-47
QSU1 Handsfree unit	5-50
Handsfree unit on a QSU71 telephone set	5-52
QKK8 Automatic Answerback	5-54
QKM1 1 adapter kit	5-57
QKM13 light probe kit	5-58
QUT1 power unit and transformer	5-66
M2000/M2317/M3000 Data Options	5-76
M2006, M2008, M2016S , M2616 and M2216ACD	5-84
Meridian Programmable Data Adapter	5-86
Power Supply Board	5-88
Display	5-94
External Alerter Board	5-100
Key Expansion Modules	5-103
Wall mounting	5-106
Self test	5-107
Troubleshooting	5-109

Introduction

This document contains the installation procedures for attendant consoles, telephone sets, and add-on modules.

“Wiring installation” includes information for the wiring for all telephone sets and attendant consoles.

“Attendant consoles” describes the installation and removal process for QCW-type, and **M1250/M2250** attendant consoles.

Procedures for installing and removing the SL-1, **M1109, M2000, M2006/M2008, M2016S, M2216, M2616, and M3000** telephone sets are found in “Telephone sets.”

Installation and removal information for all add-on modules and options-for all sets and attendant consoles is found in “Add-on modules.”



1



Wiring installation

Wiring for telephone sets and attendant consoles

This chapter discusses the installation and removal procedures for wiring and calling for telephone sets and attendant consoles.

Each 500/2500 type telephone set requires one pair of Z station wire or equivalent. Each SL-1 telephone requires two pairs of Z station wire or equivalent. You may use existing 16 or 25 pair connectorized cable. Each attendant console requires a 16-pair cable terminated on an **amphenol** connector.

When zone cabling and conduit are used, assign a block of numbers or letters to each zone (see Figure 2-2). **Allow** for growth when assigning blocks of numbers.

Cable markers are normally an adhesive-backed cloth tape $1/2$ inch wide by $3-1/2$ inch long (15 by 65 mm) with preprinted numbers.

For limits and cabling refer to Figures 2-3 through 2-5.

Figure 2-1
Apparatus designations

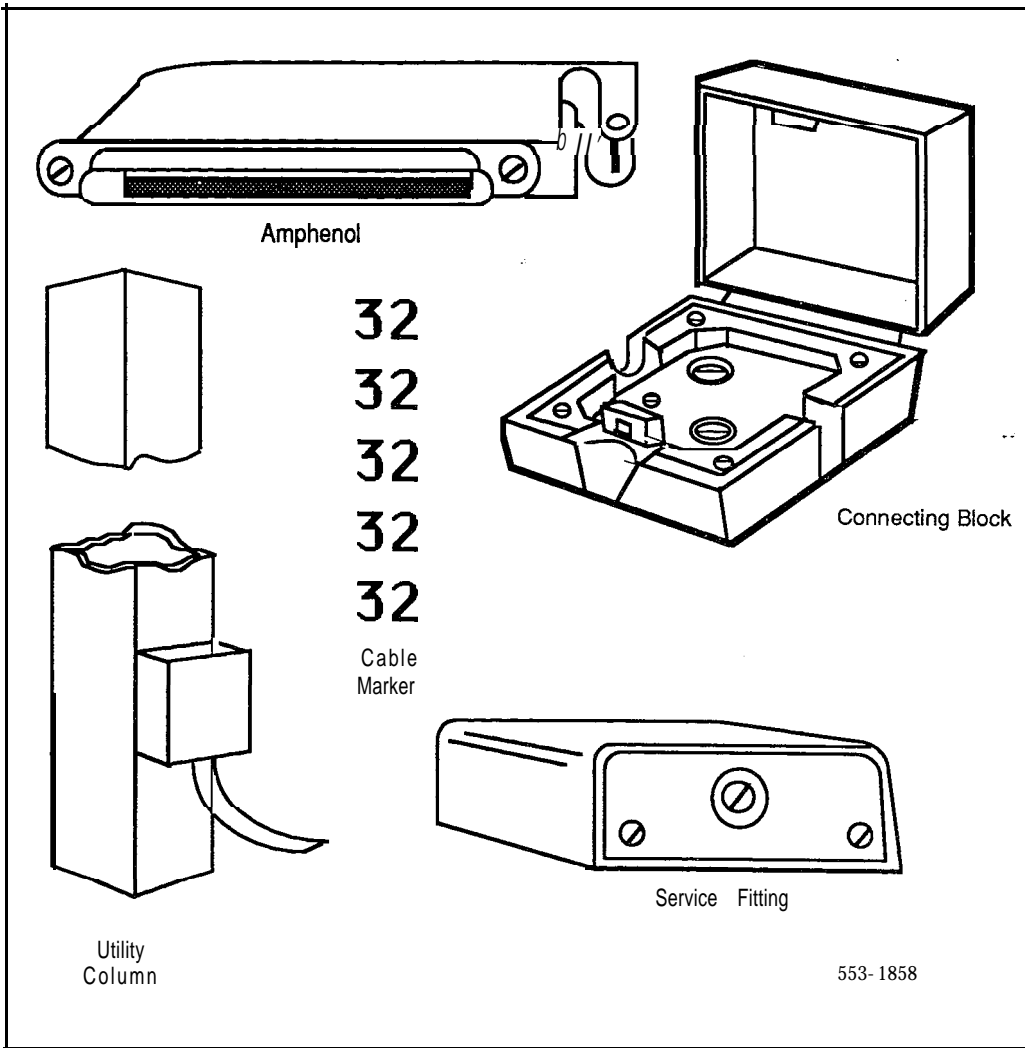
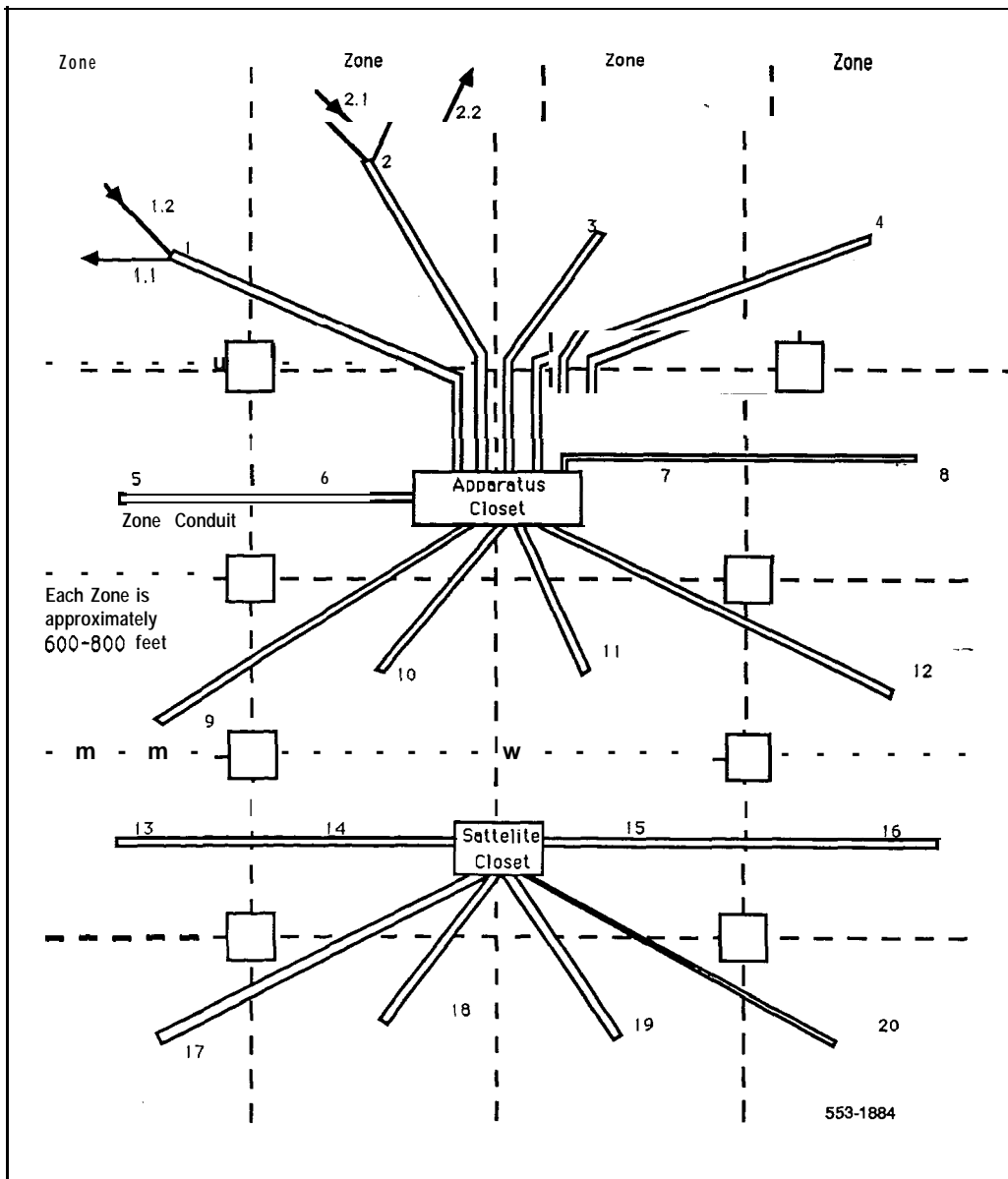

Figure 2-2
Zone cabling and conduit assignment



Procedure 2-1
Installing wiring

- 1 Assign a number to the wire or cable used.
- 2 Attach the assigned number to the wire or cable at the end nearest the telephone set, using a cable marker.
- 3 Run wire or cable between the telephone set location and nearest cross-connect point (if not previously run).
- 4 Connect cable or wire to telephone set connecting block.
- 5 Designate telephone set connecting block.
- 6 Cross-connect pairs at intermediate cross-connect points (if required) and terminate at SL-1 cross-connect terminal.
- 7 Terminate leads at cross-connect terminal and designate blocks according to house cable plan.

Table 2-1
Terminal connections

Connecting Block Designations			Inside Wiring Colors	
NE-47QA or QBB1B	NE-284-74-5001 Adapter	NE-625F TELADAPT	Z Station Wire	16/25 Pair Cable
G	1T	T1 (G)	G	W-BL
R	1R	R1 (R)	R	BL-W
BK	X1	AUX (BK)	BK	w-o
Y	x2	GND (Y)	Y	o-w
5	R	T2 (BL)		W-SL
6	B	R2 (W)		SL-W

Normal operating ranges

Telephones. The following indicates the normal operating ranges for **SL-1** telephone sets, with and without add-on modules.

- **189 Ω** or 6000 cable feet (1830 m) whichever is reached first. For example:

22 awg wire range = 6000 feet (1830 m)

24 awg wire range = 3700 feet (1125 m)

26 awg wire range = 2300 feet (700 m)

- SL-1 telephones equipped **with a QKK1** extension kit have a maximum range of 8000 feet (2440 m). For example:

22 awg wire range = 8000 feet (2440 m)

24 awg wire range = 5500 feet (1675 m)

26 awg wire range = 1125 feet (1125 m)

The outside plant cable must not exceed 0.085 Ω per mile (1600 m).

Note: The 24 V and 15 V supplies can be obtained from **QUT1** centralized power supply located at the cross-connect terminal. A separate fuse must be used for each set. --

- Meridian Modular Telephones have a maximum permissible loop length of 3500 ft (915 m), assuming 24 AWG (0.5 mm) wire with no bridge taps. A 15.5 **dB** loss at 256 KHz defines the loop length limit

Attendant consoles. The following indicates the normal operating ranges for the **QCW1C** (or earlier vintage), and **QCW2A** attendant consoles, with and without add-on modules.

- **189Ω** or 6000 cable feet (1830 m) whichever is reached first. For example:

22 awg wire range = 6000 feet (1830 m)

24 awg wire range = 3700 feet (1125 m)

26 awg wire range = 2300 feet (700 m)

The normal operating range of the **QCW1D**, and **QCW2B** (or later vintage) attendant consoles is 8000 cable feet (2440 m) using cable rated at a maximum of 0.085 μ F per mile (1600 m). For example:

22 awg wire range = 8000 feet (2440 m)

24 awg wire range = 5500 feet (1675 m)

26 awg wire range = 1125 feet (1125 m)

Note: The 24V and 15V supplies can be obtained from **QUT1** centralized power supply located at the cross-connect terminal. A separate fuse must be used for each set.

24V power can also be provided from a **QPC61** line pack. The maximum resistance is 30 Ω .

- M2250 Attendant consoles have a maximum permissible loop length of 3500 ft (915 m), assuming 24 AWG (0.5 mm) wire with no bridge taps. A 15.5 dB loss at 256 KHz defines the loop length limit.

Figure 2-3
NE-500/2500-type telephone sets — limits and cabling

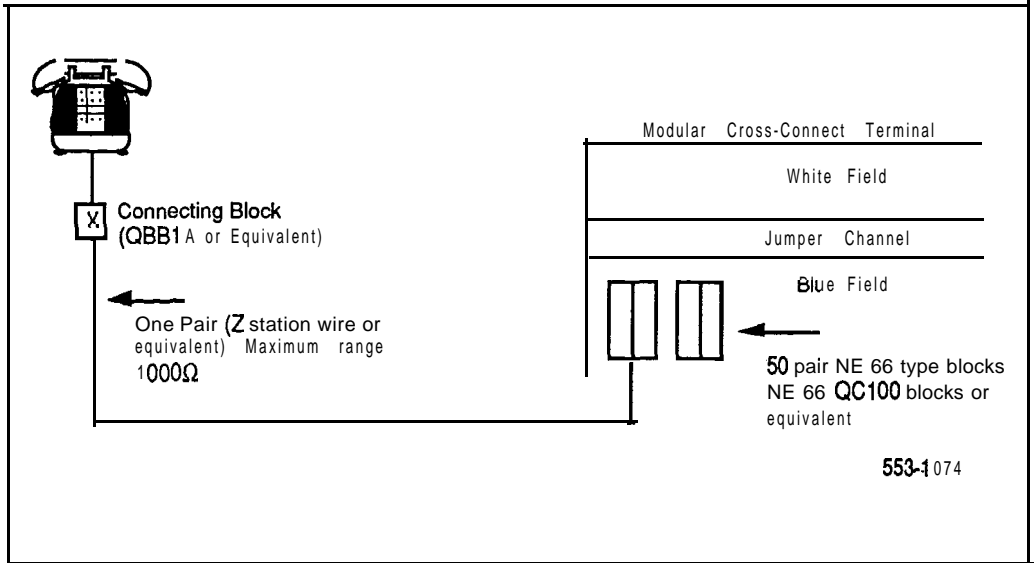

2-8 Wiring

Figure 2-4
SL-1 telephones — limits and cabling

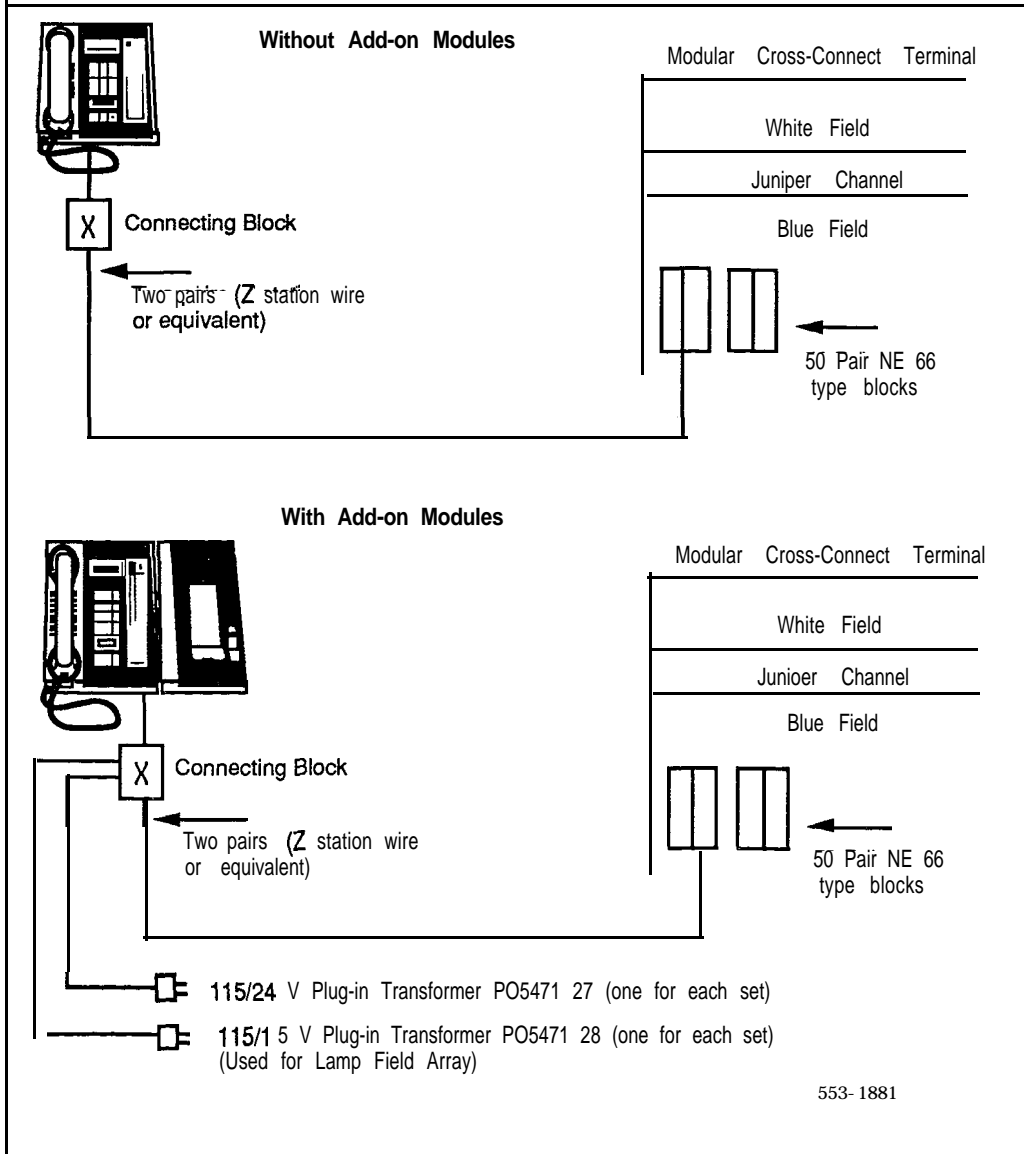
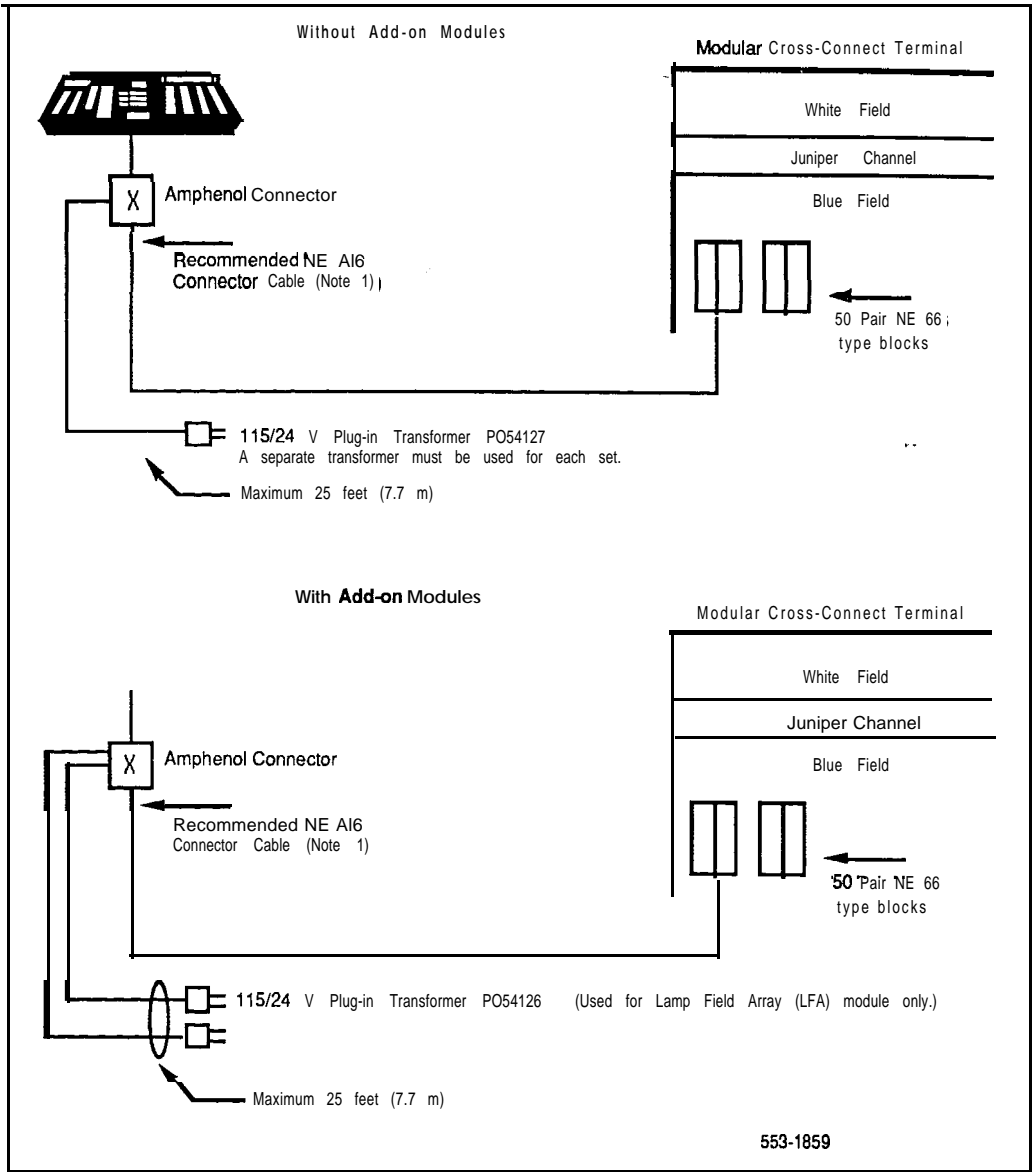

Figure 2-5
QCW type attendant console — limits and cabling



2-10 Wiring



1



Attendant consoles

Packing and unpacking

Use proper care while unpacking any attendant console. Check for damaged containers so that appropriate claims can be made to the transport company for items damaged in transit.

If an attendant console has to be returned to the factory, ensure that it is packed in the appropriate container to avoid damage during transit. Remember to include all loose parts (cords, handset, power unit, labels, lenses) in the shipment.

Installation and removal

Use the following procedures to install and remove QCW and M1250 -- attendant consoles.

Note: Although QCW and **M1250/M2250** attendant consoles do not require a static discharge ground connection, the connection should be installed to protect any earlier attendant console vintages that may be used as replacements.

Choose a clean, level work surface and place several sheets of soft, clean paper between the attendant console and the work surface. This will prevent scratching or otherwise damaging the top cover, Liquid Crystal Display (LCD) indicators and screen, and the feature keys of the attendant console.

Procedure 3-1
Installing QCW attendant consoles

- 1 **Ensure** that a 16-pair or 25-pair cable equipped with a 25-pair **amphenol connector is installed** at the **attendant console's** location.
- 2 Unpack and inspect the attendant console for **damage**. If the attendant console is damaged, notify your supplier.
- 3 Designate the attendant console according to the features provided (see Procedure 3-7).
- 4 Connect the **amphenol** connector on the attendant console line cord to the **amphenol** connector on the attendant console cable.
- 5 Cross-connect the attendant console at the cross-connect terminal (see Procedure 3-8).
- 6 Using a minimum of 24 AWG cross-connect wire, connect a static discharge ground (use a water pipe or the building main ground system) to pins 15 and 40 (slate-black pair) of the attendant console cable at the cross-connect terminal nearest the attendant console location. Connect the ground within 200 ft (68 m) of the attendant console using an approved ground connector or a clamp. Do not connect the attendant console to the SL-1 System ground.
- 7 Remove the top cover from the attendant console:
 - Place the attendant console on a desk with the front edge slightly beyond the edge of the desk.
 - Insert a paper clip into each release hole in the front edge of the attendant console housing.
 - Press the releaser through the release hole in against the top cover until the top cover releases.
 - Lift off the top cover.
 - Unscrew the captive retaining screws securing the cover to the housing.
 - Remove the cover.

—continued—

- 8 With a voltmeter, measure the AC and DC voltages between the metal frame of the attendant console and the quick-connect terminal VSS **1A** on the lower left side of the attendant console circuit board.

Make sure that the voltage measurements are less than ± 40 V. If **the** voltage is greater than ± 40 V, grounding is inadequate and a better ground must be connected.

- 9 Replace the attendant console top cover:
- Place the attendant console on a desk with the front edge slightly beyond the edge of the desk.
 - Fit the cover to the housing and tighten the captive retaining screws.
 - Position the faceplate so that the keys will pass through the cutouts in the top cover.
 - Tilt the back edge of the top cover towards the rear of the attendant console and insert the locating tabs into the slots on the attendant console cover.
 - Keeping the locating tabs in the slots, tilt the front edge of the top cover down, passing the keys through the cutouts in the top cover.
 - Press **the** front edge of the faceplate down until the top cover catches snap into place.
 - Ensure that the top cover is securely held in place without binding the keys.
- 10 Configure **the** attendant console in the SL-1 system. Refer to *SL-1 XII input/output guide* (553-3001-400).

Figure 3-1
Typical QCW type attendant console faceplate layout

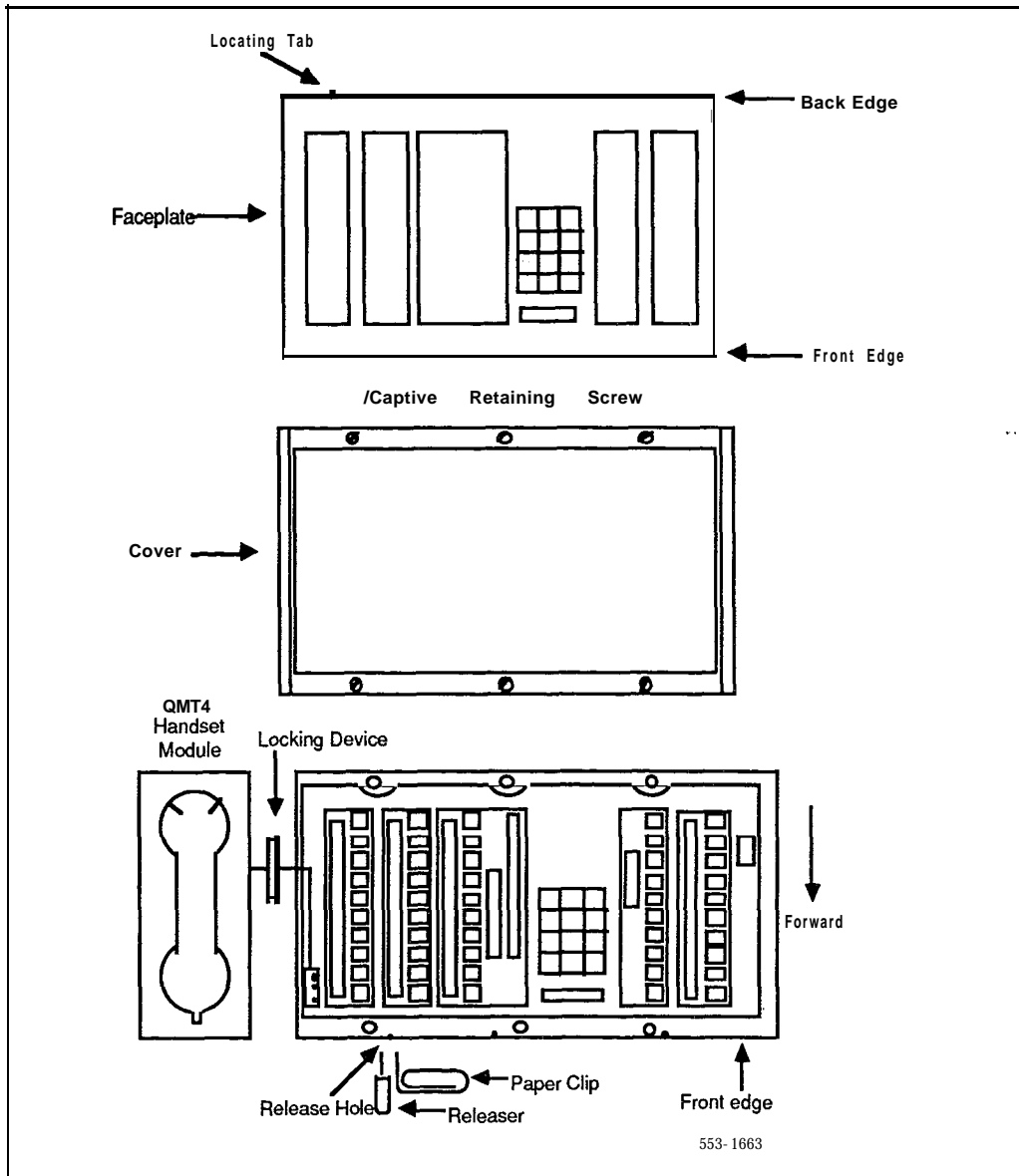

Procedure 3-2
Installing the MI 250/M2250 attendant consoles

- 1 Ensure that a **16-pair** or 25-pair cable-equipped with a 25-pair **amphenol** connector is installed at the attendant console's location.
- 2 Unpack and inspect the attendant console for damage. If the console is damaged, notify your supplier.
- 3 Designate the console according to the features provided (see Figures 3-5 through 3-8).
- 4 Connect the **amphenol** plug on the attendant console to the **amphenol** jack on the console cable (see Figure 3-2 for the MI250 attendant console, and Figure 3-3 for the M2250 attendant console).
 - Fasten the **amphenol** connectors together and secure the captive screws on the cable.
 - Ensure that the connectors are secured in a connector mounting, if provided, or to the wall. Do not leave connectors unprotected on the floor.
- 5 Add a line circuit for the attendant console, if not already done. Refer to *Circuit pack installation and testing (553-3001-211)*.
- 6 Cross-connect the attendant console at the cross-connect terminal (see Procedure 3-8).

-continued-

- 7 (M1250 only) Using a minimum of 24 AWG cross-connect wire, connect a static discharge ground (use a water pipe or the building main ground system) to pins 15 and 40 (slate-black pair) of the attendant console cable at the cross-connect terminal nearest the console location. Connect the ground within **200** ft (68 m) of the attendant console using an approved ground connector or a clamp. Do not connect the console to the SL-1 System ground.
- 8 Enter the related attendant console data in the SL- 1 System. Refer to ***SL-1 XII input/output guide*** (553-3001-400).
- 9 Test the console features using the attendant console user guide.

Note: Refer to Assembly ***and installation of apparatus*** (553-2YY1-210) for circuit pack installation procedures.

Procedure 3-3 **Removing the MI 250 and M2250 attendant consoles**

- 1 Remove related attendant console data from SL-1 System memory. Refer to ***SL-1 XII input/output guide*** (553-3001-400).
- 2 Locate and remove cross-connections from the attendant console cable at the cross-connect terminal (see Procedure 3-8).
- 3 Remove the circuit pack if required. Refer to ***Assembly and installation of apparatus*** (553-2YY1-210).

Note: Do not remove the circuit pack if any of the remaining units on the pack are assigned.

- 4 Disconnect the **amphenol** connector on the end of the cable that leads to the cross-connect terminal from the connector on the cable leading to the attendant console.
- 5 Pack the attendant console, handset and cords in a suitable container.

Figure 3-2
MI250 assembly drawing (exploded view)

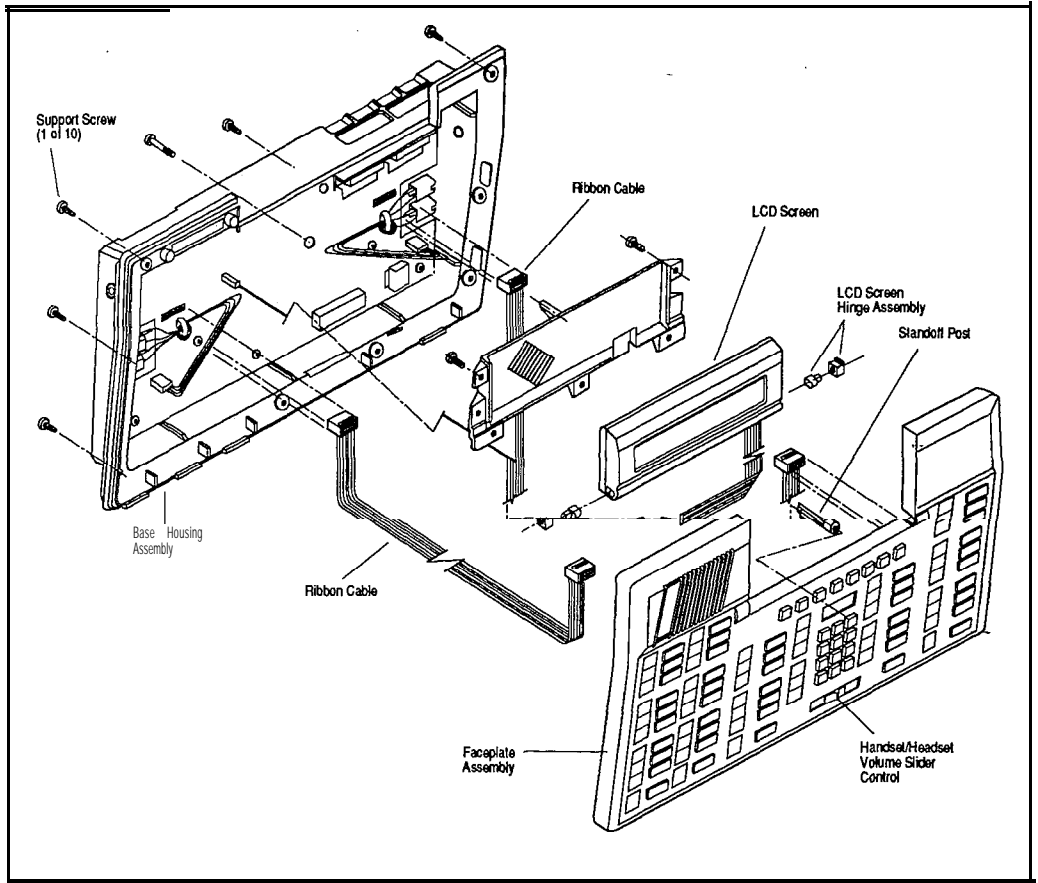
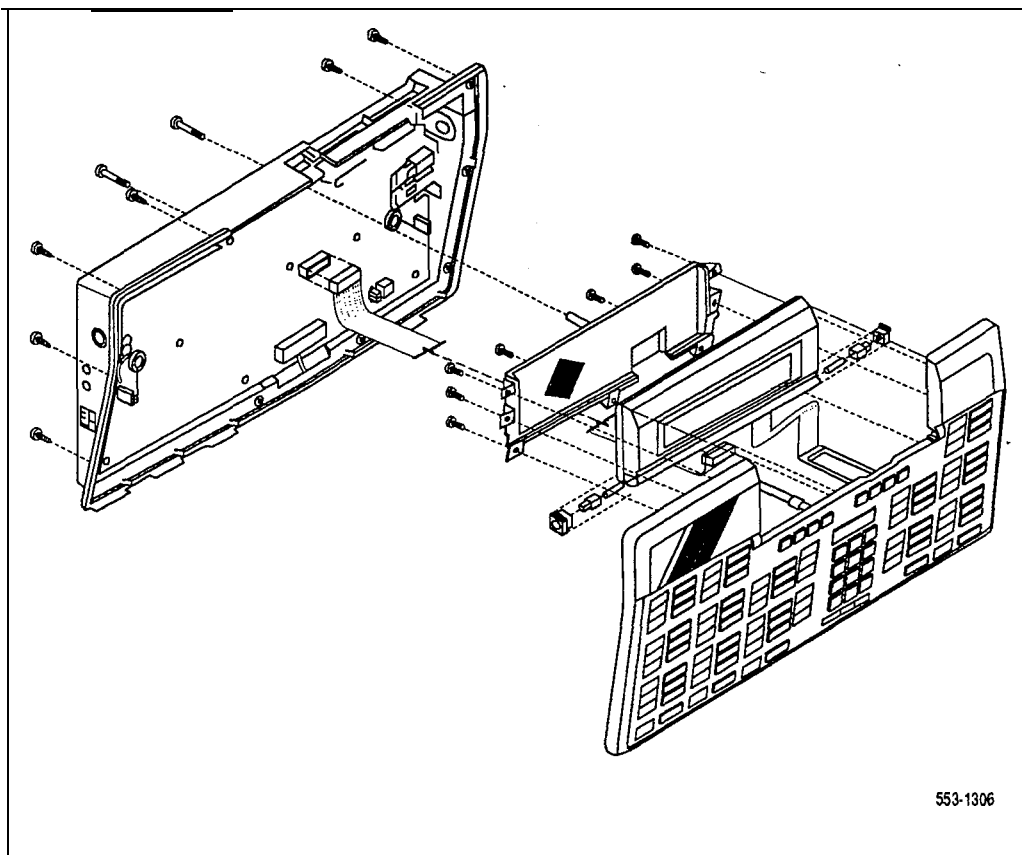

Figure 3-3
M2250 assembly drawing (exploded view)



Procedure 3-4**Removing M1 250/M2250 attendant console top cover**

- 1 Disconnect any plugs and cords from the attendant console.
- 2 Remove the ten 10 mm fastening screws in the flange of the attendant console, as well as one 10 mm and one 40 mm screw on the base of the attendant console.
- 3 Holding the top cover and the base together by hand, turn the attendant console right-side up and place it back on the work surface.
- 4 Carefully lift the faceplate straight up and disconnect the following cable connections:

on the M1250

J 1 — 16 pin plug ribbon cable,

J2 — 16 pin plug ribbon cable,

J7 — 2 pin speaker lead.

on the M2250

J2 — 20 pin plug ribbon cable

When setting the QMT2 switch on the M1250 attendant console's **PCB₂**, ON indicates that the **QMT2** is enabled, OFF indicates it is disabled (see Procedure 3-5). The status of the switch can be queried by going to the diagnostics menu and selecting the QMT2 option. The Display menu CHANGE feature provides only a temporary change to the **QMT2** status.

Note: On attendant consoles with a digit display attached to the top cover, do not connect or disconnect cable to digit display unless the attendant console line cord is disconnected.

Procedure 3-5
Installing M1250/M2250 attendant console top cover

- 1 Set the **QMT2** dip switch. To locate the dip switch, look at the attendant console from the top. The **QMT2** dip switch is the only dip switch on the topmost circuit board. Set switch to ON (enable **QMT2**) or OFF (disable **QMT2**).

Note: The **QMT2** feature must be enabled in system software. Refer to LD12, *SL-I XII Input/output guide* (553-3001-400).

- 2 Carefully lift the top cover straight up and make the following cable connections:

on the M1250

J1 — 16 pin plug ribbon cable

J2 — 16 pin plug ribbon cable

J7 — 2 pin speaker lead

on the M2250

J2 — 20 pin plug ribbon cable

- 3 Put the top cover back on the attendant console:
 - Place the top cover onto the base housing, and turn the attendant console upside-down.
 - Reinsert and tighten the ten 10 mm fastening screws on the flange.
 - Reinsert and tighten one 10 mm, and one 40 mm fastening screw on the back.
- 4 Return the attendant console to its working position, reconnect plugs and cords, and test features.

Procedure 3-6
Loopback test on the M1250 and M2250 attendant consoles

- 1 Make a **loopback** connector. Prepare a blank 25 way RS-232 male connector by internally connecting pins 2 and 3 together with strapping wire.
- 2 Press the Shift key. This accesses Level 1 mode.
- 3 Press the F4 function key to access the Diagnostics menu on the LCD screen.
- 4 Plug the **loopback** connector into the **Dataport** jack in the back of the console.
- 5 Select the **Dataport** option from the Diagnostics menu by keying in the number associated with that option. The LCD screen displays OK when the test is successfully completed.

If there is a hardware fault in the **M1250**, **90H** is displayed. If there is a hardware fault on the **M2250**, **A0H** is displayed.

If the blank RS-232 connector is not plugged into the **dataport** correctly (Step 3), the display will read 90H or A0H.

- 6 Press the asterisk (*) key to repeat the test. --
- 7 To exit the test mode press the octothorpe (#). This returns you to the main menu.
- 8 Press the octothorpe to return to normal operating mode.
- 9 Remove the **loopback** connector from the **Dataport** RS-232 jack.

Designating attendant consoles

Refer to the work order to determine features and key designations for each attendant console. Designate each key on the attendant console by placing its feature **name (from the** designation sheet) in **the key** cap that fits on the key.

For the QCW type attendant console, the Directory Number (DN) designation window is located beneath **the** keypad on the face of the attendant console. The DN designation window on the M1250 attendant console is located above the keypad.

Procedure 3-7

Designating attendant consoles

- 1 Remove **the** cap from each key requiring a designation by gently pulling upwards on the cap.
- 2 Remove the appropriate designation from the sheet of designations.
- 3 Place the designation in the cap, place the cap over the corresponding key and gently press down. Repeat **this** procedure for all keys requiring designations.
- 4 Insert a paper clip in the hole at the left or right end of **the** DN designation window. Pry the window open.
- 5 Insert the number tag, and replace **the** designation window.

The following figures show the typical key designations for QCW type, and M 1250 attendant consoles:

- Figure 3-4 shows the QCW attendant console designations.
- Figures 3-5 and 3-6 show the key designations for the M1250/M2250 attendant console in Shift mode.
- Figures 3-7 and 3-8 show the M1250/M2250 attendant console in unShift mode.

Figure 3-4
 Typical key designation for QCW attendant console

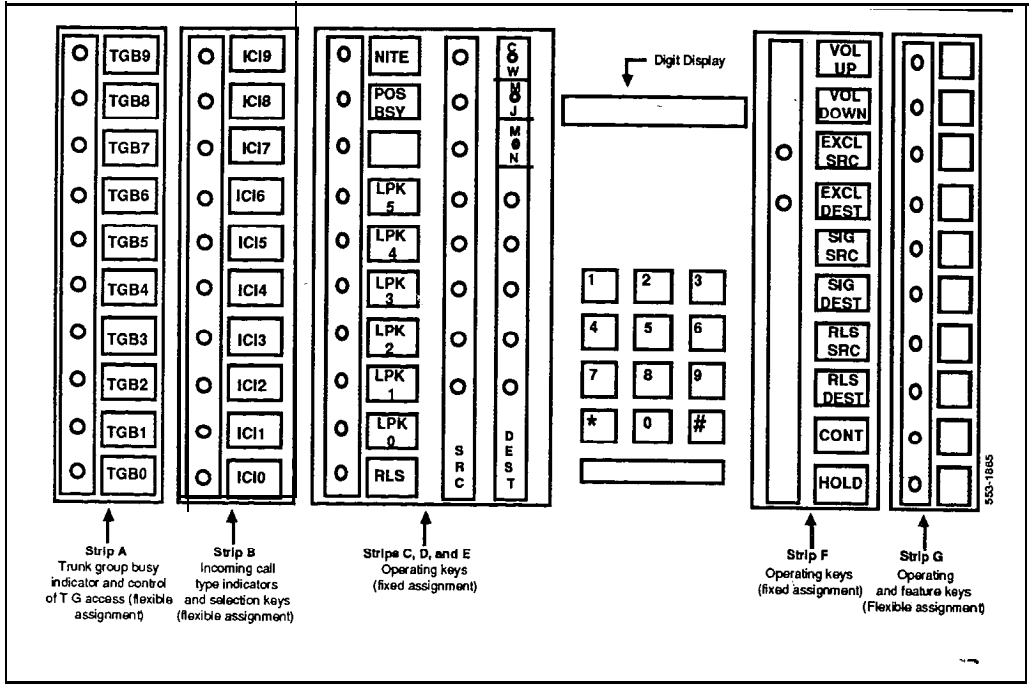
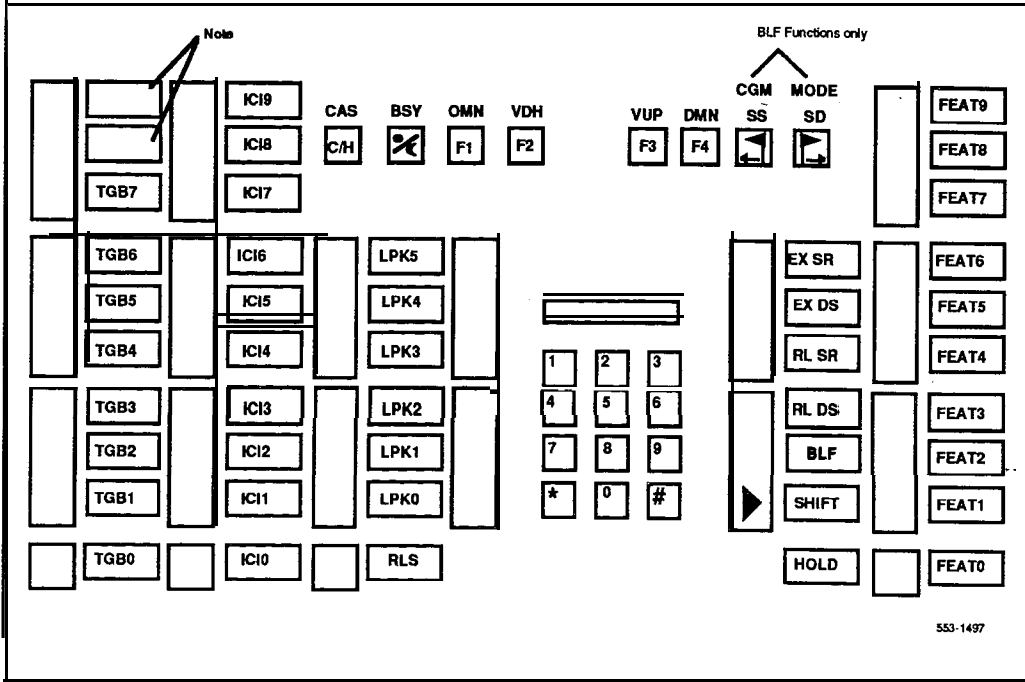
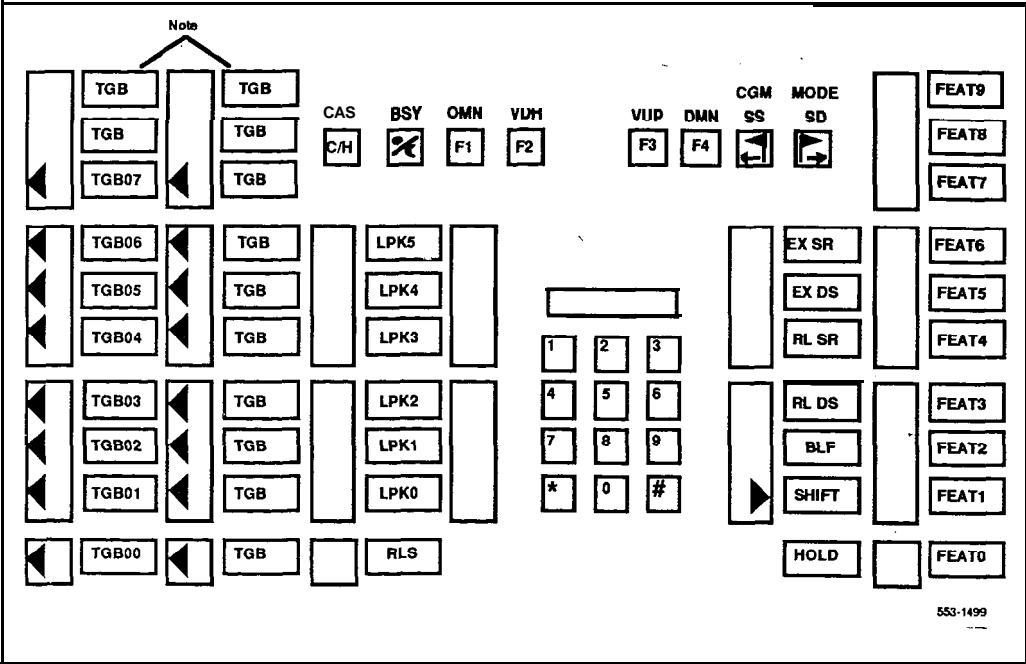

Figure 3-5
M1250/M2250 key designations in Shift mode (**QMT2** not enabled)



Note: These **two** keys are used as Trunk Group Busy keys 08 and 09 on the **M2250** attendant console. They are not used on the **M1250** attendant console.

Figure 3-6
 MI 250/M2250 key designations in Shift mode (QMT2 enabled)



Note: The top two keys in these columns are used as Trunk Group Busy keys only on the M2250. Therefore, the numbering scheme is as follows:

MI250		M2250	
		TGB09	TGB19
		TGB08	TGB18
TGB07	TGB15	TGB07	TGB17
TGB06	TGB 14	TGB06	TGB16
TGB05	TGB13	TGB05	TGB15
TGB04	TGB12	TGB04	TGB 14
TGB03	TGB11	TGB03	TGB 13
TGB02	TGB10	TGB02	TGB12
TGB01	TGB09	TGB01	TGB 11
TGB00	TGB08	TGB00	TGB10

3-16 Attendant consoles

Figure 3-7
M1250/M2250 key designations in unShift mode (QMT2 enabled)

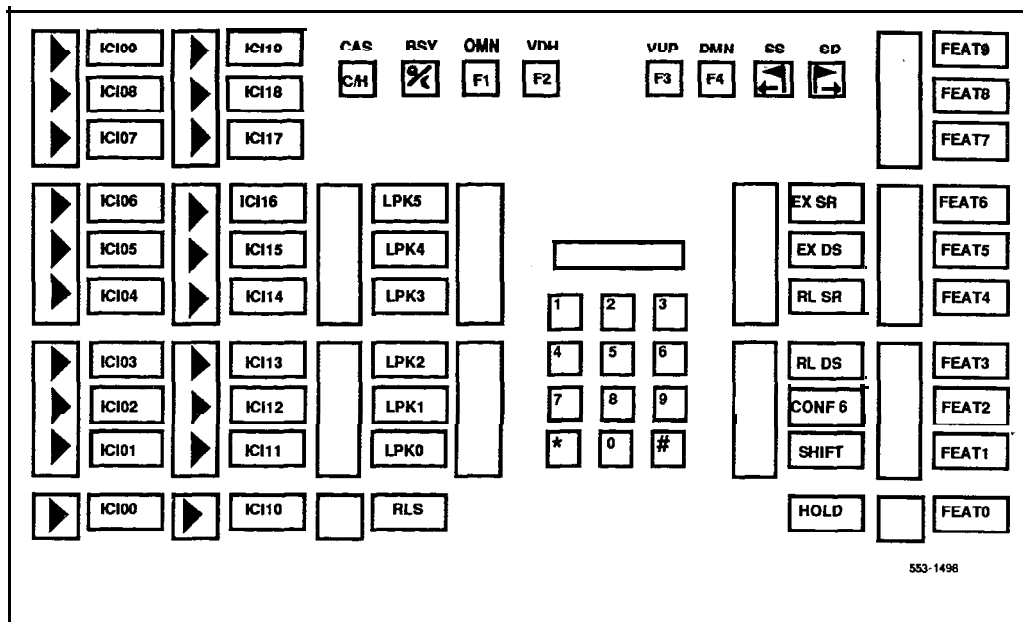
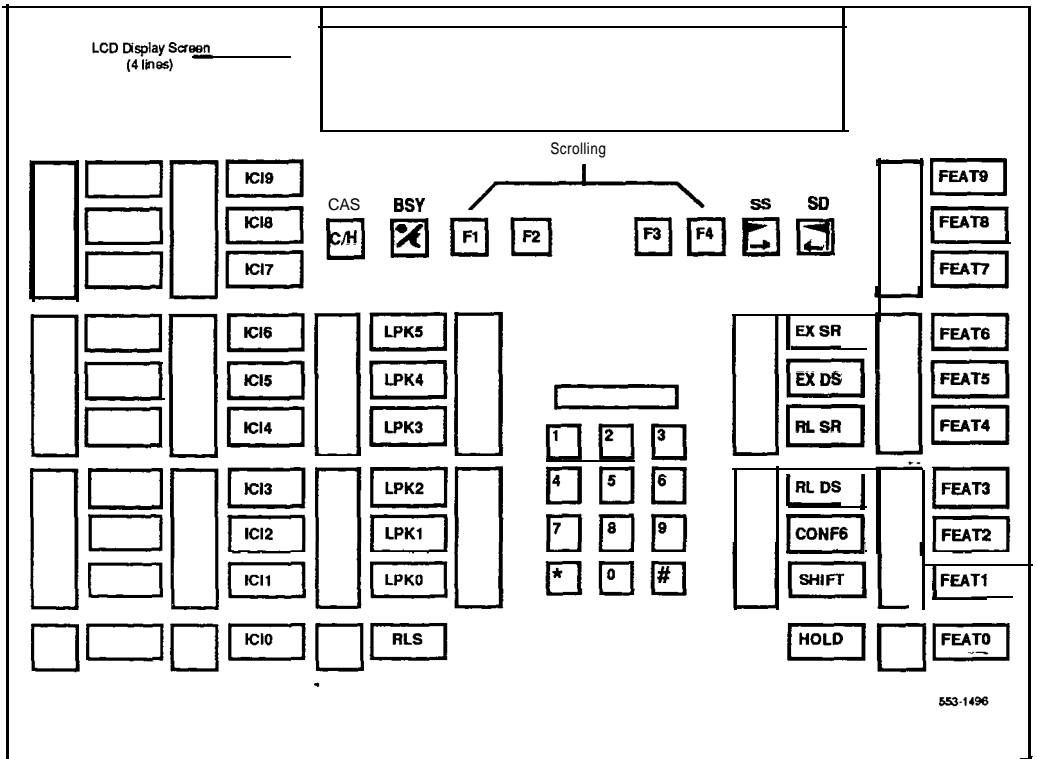

Figure 3-8
M1250/M2250 key designations in unShift mode (QMT2 not enabled)



Cross connecting attendant consoles

Set terminations are located on the vertical side of the distributing frame (when frame mounted blocks are used) and in the blue field (when wall mounted blocks are used).

Line circuit pack (TN) terminations are located on the horizontal side of the distributing frame when frame mounted blocks are used and in the white field when wall mounted blocks are used.

Procedure 3-8

Cross-connecting attendant consoles

- 1 Locate attendant console terminations at cross-connect terminal.
- 2 Connect Z-type cross-connecting wire to the leads of the attendant console.
- 3 Locate line circuit pack (TN) terminations.
- 4 Run and connect the other end of the cross-connecting wire to the assigned TN terminal block.

Table 3-1

Type Z cross-connecting wire

Size	Gauge	Color	Designation
1 pr	24	Y-BL	Tip
		BL-Y	Ring
3 pr	24	W-BL	Voice T
		BL-W	Voice R
		w-o	Signal T
		o-w	Signal R
		W-G	Power
		G-W	Power

Table 3-2
Inside wiring colors

Z Station Wire	16/25 pair cable	Connect to equipment TN
G	W-BL	1 st pair Tip
R	BL-W	1 st pair Ring
BK	w - o	2nd pair Tip
Y	o - w	2nd pair Ring

The following notes refer to Figure 3-9, QCW and M1250 attendant console cross-connections.

Note 1: Attendant consoles require 24V power. Attendant consoles equipped with the **QMT3** module require 15V power in addition to the 24V power supply.

Note 2: 24V power may be obtained from the following:

- 24V transformers located within 25 feet (7.7 meters) of the console. A separate transformer is required for each attendant console.
- **QUT1** or **QUAA1** centralized power supply. A separate fuse is required for each attendant console.
- 24V can be provided by two SL-1 circuits (maximum loop resistance of 300 Ω). This cross connection must not be used if the power is obtained from a source other than the SL-1 line circuit.

Note 3: (M1250) Connect to a solid ground (not the SL-1 system ground). The maximum distance between the ground source and the attendant console must be less than 200 feet (61 meters). Run the ground directly to the console cable connector if the connection through the cross connector exceeds 200 feet (61 meters).

Note 4: When the **BLF/CGM** option is used on the **M1250/M2250**, an additional 16V dc power supply must be cabled through the **+VPS** (pin 16) and the **+VPSRTN** (pins 42 and 17) wires. The maximum loop limit from the attendant console to the connector is 120 feet (36 meters) at 24 AWG.

Figure 3-9
QCW and M1250 attendant console cross-connections

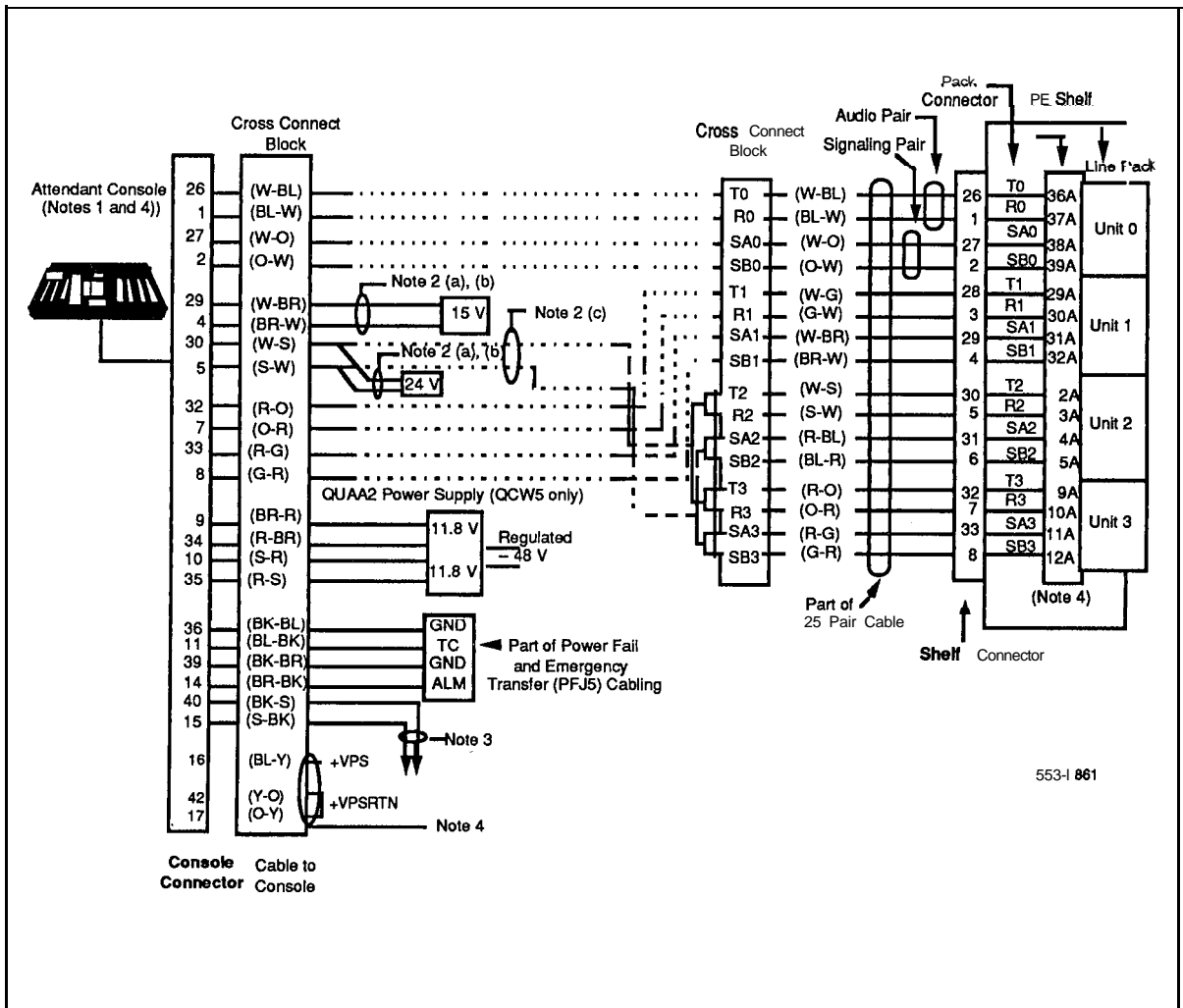
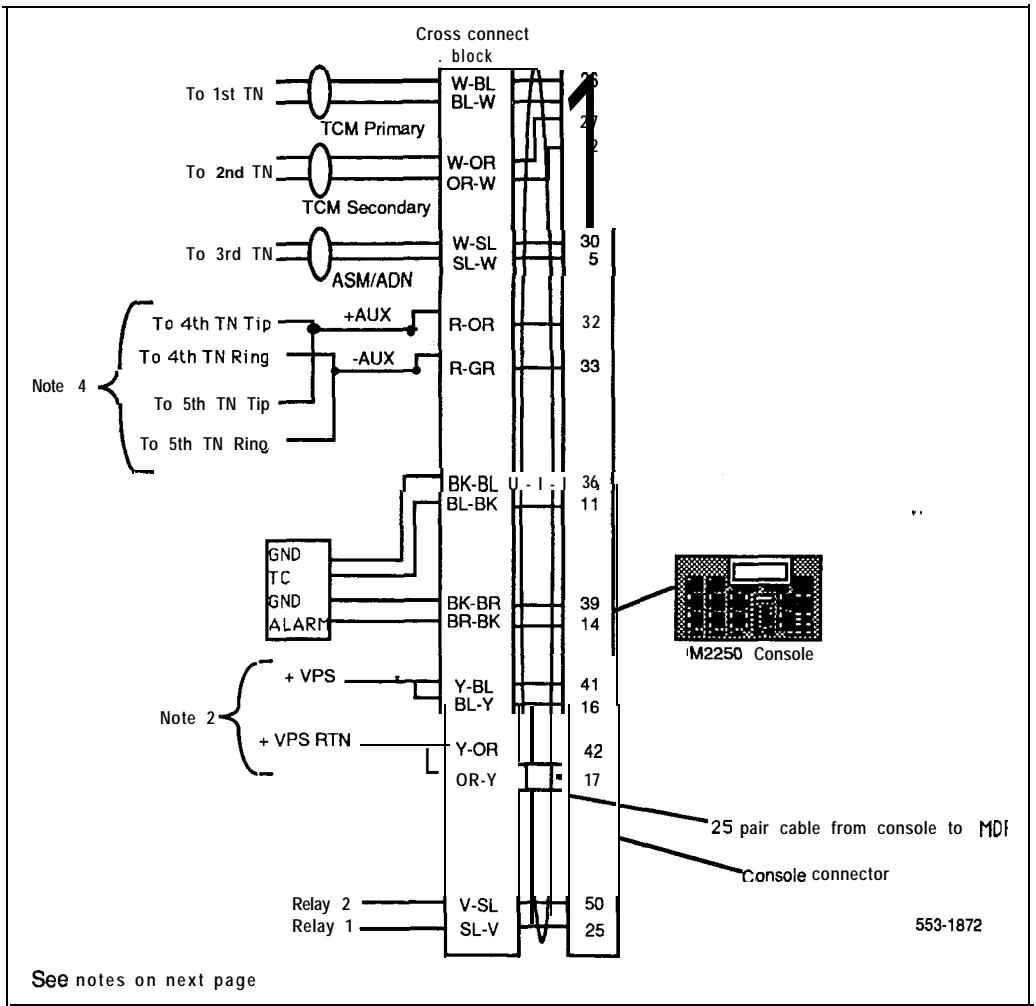

Figure 3-10 — M2250 attendant console cross connections



The following notes refer to **Figure 3-10, M2250** attendant console cross-connections.

Note 1: The M2250 is powered via the line circuits. In addition to the primary TN, secondary TN and ASM TN, two TN are cabled to the M2250 via the +AUX and -AUX leads. Maximum loop length of 3000 ft of 24 AWG wire.

Note 2: When additional options are used (**BLF**) an additional 16V dc power supply is required. The 16V dc source is cabled via +VPS and +VPS RTN leads. The maximum distance from the console to the power source is 120 feet of 24 AWG wire.

Note 3: It is recommended that 5 consecutive TN on the line circuit be allocated for each console.

Note 4: The M2550 when used with the ISDLIC requires QPC578 vintage D or later.

Table 3-3
QCW and MI 250 attendant console connections

Mounting Cord Lead Designation	16/25 PIN Number	Pair PIN Number	Connector Pair Number	Cable Color	Connected to
Voice 1 (SRC)	26 1	26 1	1T R	W-BL BL-W	1st pair of TN #1
Signal 1 (SRC)	27 2	27 2	2T R	w-o o-w	2nd pair of TN #1
Spare	28 3	28 3	T R	W-G G-W	
15V Power 15V Power	29 4	29 4.R	4T	W-Br Br-W	PO5471 28 (Note 1) Plug-in transformer
25V Power 25V Power	30 5	30 5	5T R	w-s s-w	PO5471 27 (Notes 1/2) Plug-in transformer
Spare	31 6	31 6	6T R	R-BI BI-R	
Voice 2 Voice (DEST)	32 7	32 7	7T R	R-O O-R	1 st pair of TN #2 --
Signal 2 Signal (DEST)	33 8	33 8	8T R	R-G G-R	2nd pair of TN #2
GRD 11.8V	34 9	34 9	9T R	R-BR BR-R	QUAA2 Power Supply (QCW5 only)
GRD 11.8V	35 10	35 10	10T R	R-S S-R	QUAA5 Power Supply (QCW5 only)
Emergency Transfer	36 11	36 11	11T R	BK-BL BL-BK	GND (Note 3) TC (Note 4)
—continued—					

Table 3-3
QCW and MI250 attendant console connections (continued)

Mounting Cord	16/25		Pair	Connector	Cable	
Lead	PIN	PIN	Pair	Color	Connected to	
Designation	Number	Number	Number			
Spare	37	37	12T	BK-0		
Spare	12	12	R	0-BK		
Spare	38	38	13T	BK-G		
Spare	13	13	R	G-BK		
Major	39	39	14T	BK-BR	+GND (Note 3)	
Alarm	14	14	R	BR-BK	-ALM (Note 4)	
GND	40	40	15T	BK-S	See Static Discharge	
				GND		
GND	15	15	R	S-BK	Installation Procedure	
Spare	41	42-45	16T	Y-BL		
	16	16-20	R	BL-Y		

Note 1: The **15V** and **25V** supplies can be obtained at the **cross-connect** terminal when a **QUT1** power supply is provided.

Note 2: The **25V** supply can also be obtained from two additional units on a line circuit pack.

Note 3: Connect to Pin 3 or 28 of appropriate **PFJ5** terminal block.

Note 4: Connect TC to Pin 29 or 5 and ALM to Pin 4 or 31 of appropriate **PFJ5** terminal block.

Note 5: This applies to QPC297 and QPC61 circuit packs.

Table 3-4
M2250 attendant console connections

Mounting Cord	16/25	Pair	Connector	Cable	
Lead Designation	PIN Number	Pair Number	Color	Connected to	
TCM primary	26 1	1T R	W-BL BL-W	TN #1	
TCM secondary	27 2	2T R	w-o o-w	TN #2	
Spare	30 5	3T R	W-G G-W	TN #3	
AUX Line Power	29 4	4T	W-Br Br-W	TN #4	
AUX Line Power	30 5	5T R	w-s s-w	TN #5	
Spare	31 6	6T R	R-BI BI-R		
AUX +	32 7	7T R	R-O O-R		
AUX -	33 8	8T R	R-G G-R		
Spare	34 9	9T R	R-BR BR-R		
Spare	35 10	10T R	R-S S-R		
Emergency Transfer	36 11	11T R	BK-BL BL-BK	GND (Note 1) TC (Note 2)	
-continued-					

Table 3-4
M2250 attendant console connections (continued)

Mounting Cord		16/25	Pair	Connector	Cable	
Lead Designation	PIN Number		Pair Number	Color	Connected to	
Spare	37		12T	BK-0		
Spare	12		R	0-BK		
Spare	38		13T	BK-G		
Spare	13		R	G-BK		
Major Alarm	39		14T	BK-BR	+GND (Note 1)	
GND	14		R	BR-BK	-ALM (Note 2)	
+VPS	41		15T	Y-BL		
	16		R	BL-Y		
+VPS RTN	42		16T	Y-OR		
	17		R	OR-Y		

Note 1: Connect to Pin 3 or 28 of appropriate PFJ5 terminal block,

Note 2: Connect TC to Pin 29 or 5 and ALM to Pin 4 or 31 of appropriate PFJ5 terminal block.

Table 3-5
M2250 typical cross connections

Pair	Pins	Pair Color	XDLC Connections	ISDLC Connections
1T	26	W-BL	Unit	Unit
1R	1	BL-W	0	0
2T	27	w-o	Unit	Unit
2R	2	o-w	1	8
3T	28	W-G	Unit	Unit
3R	3	G-W	2	1
4T	29	W-BR	Unit	Unit
4R	4	BR-W	3	9
5T	30	w-s	Unit	Unit
5R	5	s-w	4	2
6T	31	R-BL	Unit	Unit
6R	6	BL-R	5	10
7T	32	R-O	Unit	Unit
7R	7	O-R	6	3
8T	33	R-G	Unit	Unit
8R	8	G-R	7	11
9T	34	R-BR	Unit	Unit
9R	9	BR-R	8	4
10T	35	R-S	Unit	Unit
10R	10	S-R	9	12
11T	36	BK-BL	Unit	Unit
11R	11	BL-BK	10	5
12T	37	BL-O	Unit	Unit
12R	12	O-BK	11	13
13T	38	BK-G	Unit	Unit
13R	13	G-BK	12	6
14T	39	BK-BR	Unit	Unit
14R	14	BR-BK	13	14
15T	40	BK-S	Unit	Unit
15R	15	S-BK	14	7
16T	41	Y-BL	Unit	Unit
16R	16	BL-Y	15	15



Telephone sets

Packing and unpacking

Use proper care while unpacking any digital telephone set. Check for damaged containers so that appropriate claims can be made to the transport company for items damaged in transit.

If a telephone set has to be returned to the factory, ensure that it is packed in the appropriate container to avoid damage during transit. Remember to include all loose parts (e.g. cords, handset, power unit, labels and lenses etc.) in the shipment.

Installation and removal

On QSU71 telephone sets, key 8 must be assigned as NUL, and key 9 as RLS. Do not remove the circuit pack if any remaining units on the Rack are assigned.

Procedure **4-1**

- 1 Ensure that wiring is installed to the telephone set's location.
- 2 Unpack and inspect the telephone set for damage. Assemble the handset and line cords if necessary.
- 3 Install the required designations on the telephone set.
- 4 Connect the telephone set to the connecting block or connector.
- 5 Cross-connect the telephone set wiring at the cross connect terminal.
- 6 Configure telephone set in the system. Refer to ***SL-I XII input/output guide*** (553-3001-400).

Procedure 4-2

Removing 500/2500, SL-1, MI 009, MI 109, and M1309 telephones

- 1 Remove telephone set data from system. Refer to ***SL-I XII input/output guide (553-3001-400)***.
- 2 Disconnect telephone set from connecting block or connector.
- 3 Pack **the** telephone set in a container.
- 4 If necessary, remove cross-connections for **the** set at the cross-connect terminal.
- 5 Remove the line circuit pack if required. Refer to ***Assembly and installation of apparatus (554-2YY-210)***.

Procedure 4-3

Installing SL-1 telephone set faceplate

- 1 Place the telephoneset on a desk with the front edge slightly beyond **the** edge of the desk.
- 2 Fit the cover to the housing and tighten the captive retaining screws.
- 3 Position the faceplate so that the keys will pass through the cutouts in the faceplate (see Figure 4-1).
- 4 Tilt the back edge of the faceplate towards the rear of the telephone set and insert the locating tabs into the slots on the cover. --
- 5 Keeping the locating tabs in the slots, tilt the front edge of the faceplate down, passing the keys through the cutouts in the faceplate.
- 6 Press the front edge of the faceplate down until **the** faceplate catches snap into place.
- 7 Ensure that **the** faceplate is securely held in place without binding the keys.

Figure 4-1
SL-1 telephone set faceplate

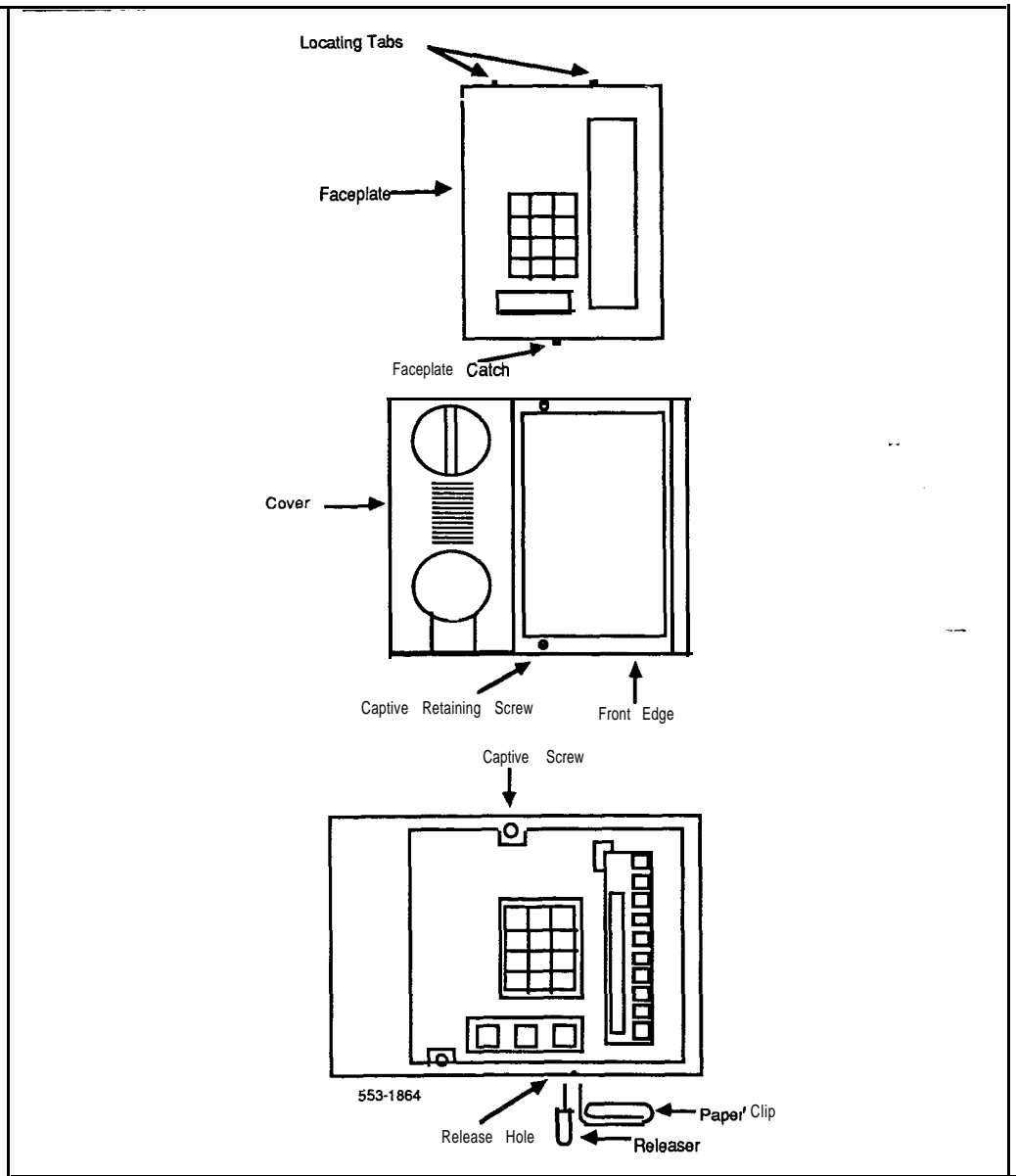

Procedure 4-4

Removing SL-1 telephone set faceplate

- 1 Place the SL-1 telephone on a desk with the front edge slightly **beyond** the edge of the desk.
- 2 Insert a paper clip into each release hole in the front edge of the set housing, and pry the faceplate open.
- 3 Lift the faceplate off.
- 4 Unscrew the captive retaining screws securing the cover to the housing, and remove the cover.



Procedure 4-5
Installing the M2000 Digital Telephones'

- 1 Complete wiring and cross-connections as shown in Figure 4-2 before connecting telephone(s) to connecting block(s).
- 2 Place the telephone set upside down on a number Of sheets of soft, clean paper on a solid level work surface to prevent damage to movable keys and the telephone face.
- 3 Connect handset cord **5-conductor** TELADAPT connectors to handset and the telephone set and snap into place.
- 4 After **connecting** handset cord to connector in the base of the telephone set, turn the smooth side of the handset cord up (away from telephone set base) before tucking it under the restraining tab to ensure that the telephone set will sit level on the desk after installation is complete.
- 5 Connect **6-connector** line cord to telephone set base.
- 6 Turn telephone set right side up and place in normal operating position.
- 7 Designate buttons for key labels.
- 8 Insert line cord TELADAPT connector into the connecting block and snap it into place.

--

Figure 4-2
M2000 Digital Telephone connections

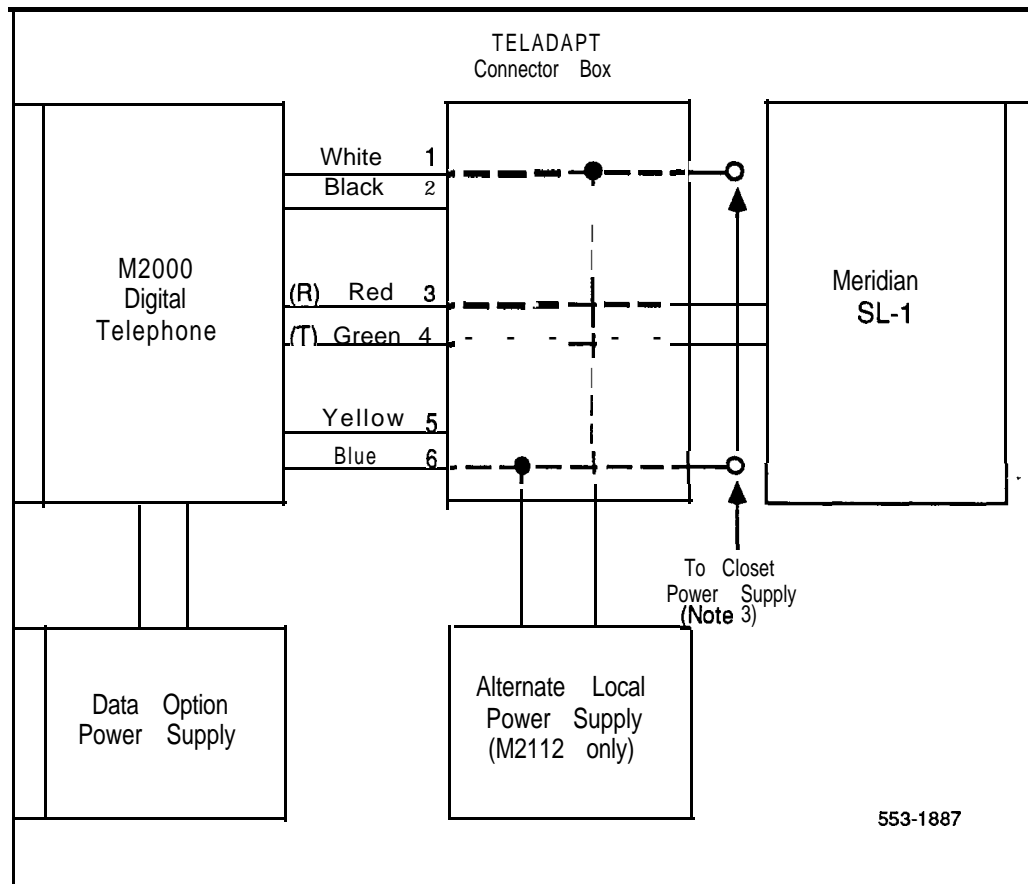

Note 1: Leads 1 and 6 are used for closet power (25V ac), or for alternate power supply, as required depending on local conditions.

Note 2: The Data Option power supply connects directly to a 5-pin connector in the rear of the telephone set.

Note 3: If a QUT1 closet power supply is used, each M2112 telephone must be powered by one tap of one winding. However, it is permissible to connect two (2) 12.5V ac windings in series to provide 25V ac for one handsfree unit.

Procedure 4-6
Installing Meridian Modular telephones
(M2006/M2008/M2016S/M2616/M2216ACD)

- 1 Complete wiring and cross-connections (loop power) before connecting telephone set to connecting block.
- 2 Place the telephone set upside down on a number of sheets of soft, clean paper on a solid, level work surface to prevent damage to movable keys and the telephone set's face.
- 3 Connect handset cord (**5-conductor TELADAPT** connectors) to handset and snap into place (not applicable to **M2216ACD**).
- 4 Connect other end of handset cord to connector in bottom cover of telephone set. Turn smooth side of handset cord up (away from telephone set bottom cover) before tucking it under the restraining tab to ensure that the set will sit level on the desk after installation is complete (not applicable to **M2216ACD**).
- 5 Connect the line cord to the telephone set bottom cover. Route the cord through channels.
- 6 Turn telephone set right side up and place in normal operating position.
- 7 Print directory number on designation card. Using a paper clip, remove number lens from set. Insert designation card and snap lens back **into** place.
- 8 Designate feature keys.
- 9 Insert line cord **TELADAPT** connector into connecting block and snap it into place.
- 10 Perform the self test (see Procedure 5-55) and acceptance test procedures. See LD 31, **SL-1 X11 input/output guide (553-3001-400)**.
- 11 Supply the user with a quick reference card and all user documentation. Make sure the SPRE number is printed on the quick reference card.

Figure 4-3
Meridian Modular Telephone connections

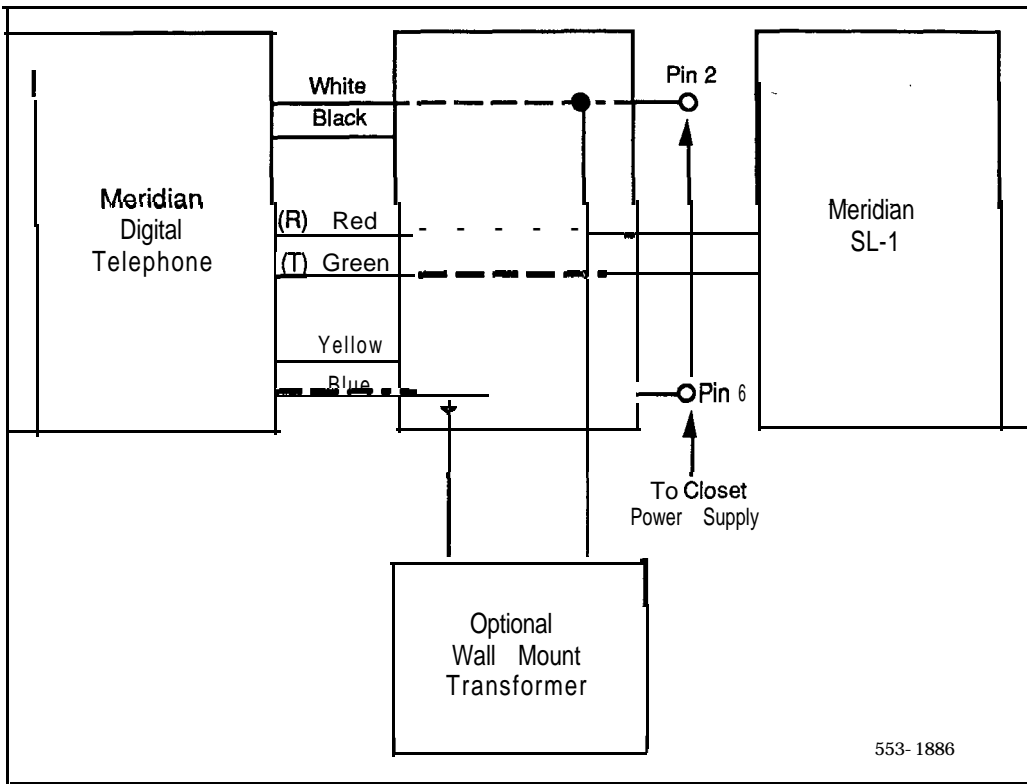

Note: The optional power may be required only if the set has options, for example, the Meridian Programmable Data Adapter.

Figure 4-4
Meridian Modular Telephone cross-connections

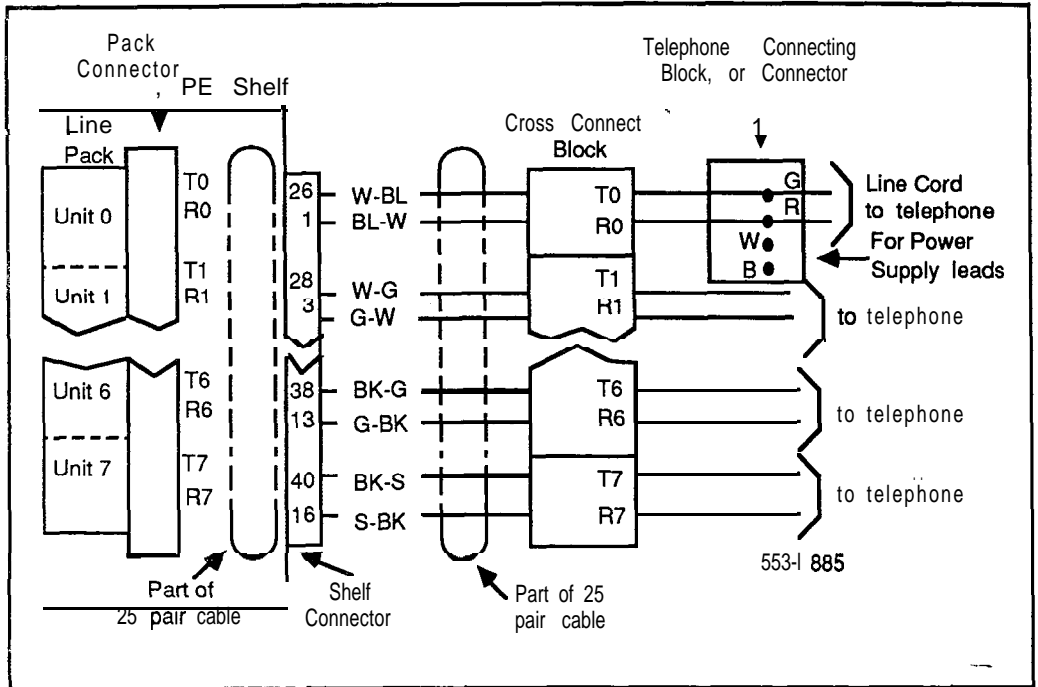

Procedure 4-7
Installing the M2317 Digital Telephone

- 1 Complete wiring and cross connection according to Figure 4-5 before connecting the telephone set to the TELADAPT connector block.
- 2 Place the telephone set upside down on a number of sheets of soft, clean paper and on a solid, level work surface to prevent damage to movable keys and the telephone set's face.
- 3 Connect the handset cord four-conductor TELADAPT connectors to the handset and to the telephone set and snap into place.
- 4 Turn the smooth side of the cord away from the telephone set base and **secure** it under the restraining tab. This ensures that the telephone set sits level after the installation is complete.
- 5 Connect the six-conductor line cord to the telephone set base, and place it under the restraining tabs.
- 6 Turn the telephone set face up, and place it in normal operating position.
- 7 Print the DN on the designation card and place it in the designation card holder.
- 8 Designate button labels for programmable keys, and place them under the button cover.
- 9 Insert the line cord TELADAPT connector block and snap it into place. Place the line cord under the restraining tabs.
- 10 Plug the 5V power supply connector into the back of the telephone set.
- 11 Plug the power supply into an ac utility outlet.
- 12 After the M2317 Digital Telephone is connected to a line that is both enabled and designated as an M2317 digital line, the startup screen displays INITIALIZATION V6.4. Within 5 seconds, the Idle state screen is displayed, and the M23 17 is operational. The term V6.4 represents the firmware issue number, and may differ with some installations.

—continued—

- 13 If the M23 17 has been connected to a line that is designated as a digital line, but is not enabled, the Display will prompt CONTACT SYSTEM ADMINISTRATOR. The line must be enabled using LD 32 from the maintenance terminal, and enabling the features outlined in the work order. Refer to **SL-1 X11 input/output guide (553-3001-400)** for the required routines, prompts and responses.

If the M23 17 has been connected to a line that is neither defined as a digital line, nor enabled, refer to **SL-1 X11 input/output guide (553-3001-400)** for required routines, prompts and responses.

- 14 Verify that all the requested features are enabled by accessing them with the soft keys, or programmable keys, from the M23 17 Telephone and observing the display screen.

Figure 4-5
M2317 Digital Telephone cross-connections

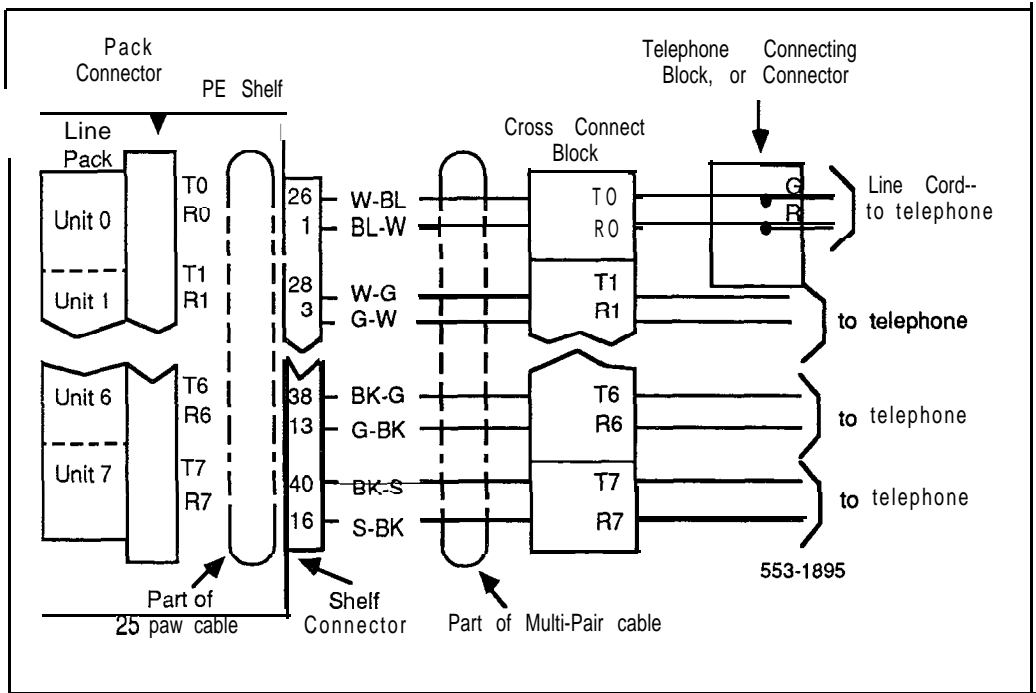

Procedure 4-8
Installing the M3000 Touchphone

- 1 Place the Touchphone upside down on a number of sheets of soft, clean paper on a solid, level work surface to prevent damage to movable keys and the telephone set's face.

Installing Asynchronous Data Option

- 2 Remove the four (4) self tapping screws that fasten the stand to the Touchphone body. Lift the stand off the locating posts in a straight, upward motion.
- 3 Snap the Dam Option into the rear of the Touchphone body, with the ribbon cable and header connector protruding from the front of the Dam Option housing.
- 4 Plug the 34 pin header connector at the end of the ribbon cable into the receptacle located in the body of the Touchphone and press firmly.

Assemble Touchphone and Stand

- 5 Place the stand over the Touchphone body and position over the four (4) locating posts.
- 6 Using the four (4) self tapping screws removed earlier, fasten the stand securely to the Touchphone body.

Connect the Cords

- 7 If the handset is not already connected to the Touchphone, connect the cord's TELADAPT connector to the Touchphone body. Route the cord under the plastic tabs in the stand and out the exit slot. Snap the other end of the cord into the handset receptacle.
- 8 Connect the line cord TELADAPT connector to the Touchphone body jack, and route the cord through the channel in the stand. Connect the other end of the line cord in the baseboard or wall connector.

-continued-

- 9 Plug the power transformer cord into the mating connector in the Touchphone body and press firmly.
- 10 Route the power cord through its channel in the stand. Plug the transformer into an ac wall outlet. The Touchphone display screen will show STARTING UP and will prompt the user to PLEASE WAIT.

Note: The characters displayed between the prompt PLEASE WAIT, and the string of five numbers at the bottom of the display are special codes used for service routines only. Don't worry about them.

Initialization

- 11 If the Touchphone being installed is connected to a line that is defined as an **M3000** Touchphone line, and is enabled, the STARTING UP screen display will automatically change to the IDLE screen display within ten seconds.

If the prompt STARTING UP. . . PLEASE WAIT remains on the screen longer than 15 seconds, means the Touchphone being installed is connected to a line defined as an **M3000** line, but is not enabled. The line must be enabled using LD 32 from the maintenance terminal, and enabling the features outlined in the work order. Refer to **SL-1 XI1 input/output guide** (553-3001-400) for the required routines, prompts and responses.

If the Touchphone being installed is connected to a line that is neither defined as a **M3000** line, nor enabled, refer to **LD1 1, SL-1 XI1 input/output guide** (553-3001-400). Refer to Step 12 for feature verification.

—continued—

Figure 4-6
M3000 Touchphone cross-connections

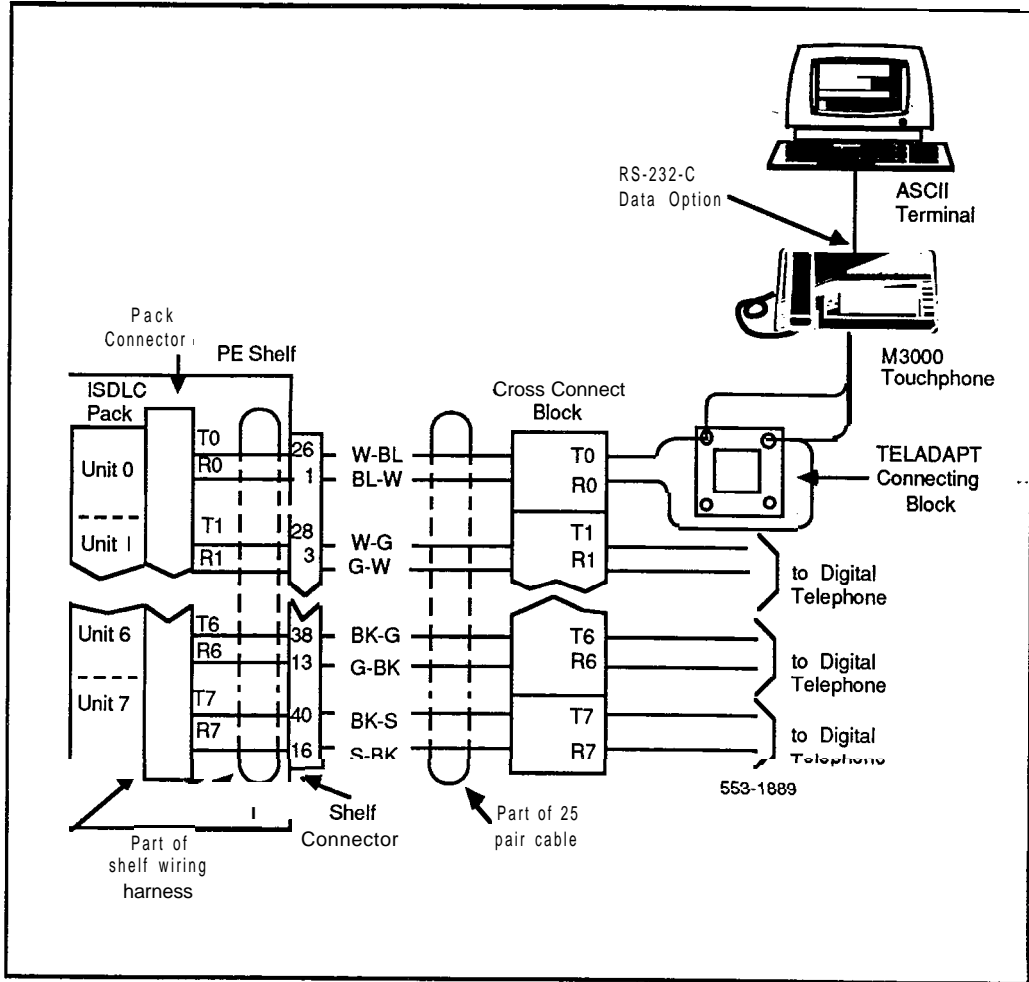

- 12 If the Touchphone to be installed has arrived directly from the factory, or if it has come from another location with an internal directory stored that is unrelated to the new location, touch positions 13 3 2 (in that sequence) in the number string at the bottom of the STARTING UP screen display prior to loading data and features.

Note: If digits **1, 3, 3**, and 2 are operated on the STARTING UP screen, the internal memory store of that Touchphone will be wiped clean.

- 13 Verify that all features requested in the work order are enabled by touching TOUCH PROFILE on the IDLE screen, then LIST FEATURES on the TOUCH PROFILE screen. Enabled features will show a black box beside them. Features not enabled will show a blank box.

The **M3000** is now operational. Should the **M3000** Touchphone fail to operate, *see M3000 Touchphone description* (553-2201-1 15).

Designating telephone sets

Before designating telephone sets, check the work order for features enabled, and key designations on the sets. Designate each key by placing its feature name (from the designation sheet) in the **key_cap** that fits on the key.



Procedure 4-9 Designating 500-type telephone sets

- 1 Remove the finger wheel and number card from its envelope.
- 2 Designate the number card with the appropriate directory number and station designator.
- 3 Insert the number card into the finger wheel (making sure the number card is properly oriented).
- 4 Place telephone set on a flat surface.
- 5 Place finger wheel over clamp on dial, with "0" hole directly over digit "9", making sure finger wheel depressions are properly positioned on prongs of clamp plate.
- 6 Rotate finger wheel counterclockwise until clamp spring snaps into notch on underside of finger wheel.

Procedure 4-10 Removing the fingerwheel from 500-type telephone sets

- 1 Place telephone set on flat surface.
- 2 Rotate fingerwheel clockwise as far as possible.
- 3 Insert a paper clip into the small hole between the digits "9" and "0" located on the edge of the grooved section of the fingerwheel.
- 4 Press down on the releaser to disengage the fingerwheel clamp spring.
- 5 Rotate the fingerwheel further clockwise until clamp spring releases.
- 6 Remove the fingerwheel when it becomes loose. Dial returns to normal position.



Procedure 4-11
Designating 2500-type telephone sets

- 1 Designation window is located directly below the dial pad. Insert paper clip into the hole at left or right end of designation window.
- 2 Gently pry the window towards the center and remove.
- 3 Insert number tag with appropriate directory number and station designator, and replace the designation window.

Procedure 4-12
Designating SL-1 telephone sets

- 1 Remove cap from each key requiring a designation.
- 2 Place designation in cap, place cap over corresponding key and gently press down. Repeat for all keys requiring designations.
- 3 Insert a paper clip into the hole at left or right end of designation window.
- 4 Gently pry the window towards the center and remove, and insert the number tag.
- 5 Replace the designation window.

--

Connecting telephone sets

Procedure 4-13 describes the connecting of SL-1 and MI 109 Compact telephone sets.

Procedure 4-14 describes the connecting of 500 and 2500-type telephone sets.

Procedure 4-1 3

Connecting SL-1 and MI 109 Compact Telephone set

- 1 Ensure that the terminal connector is compatible with the telephone set connector.
- 2 Connect set cord to terminal connecting block, or couple **amphenol** or **TELADAPT** connector (if provided).
- 3 Secure cover of connector (if provided).

Table 4-1
SL-1 Telephone and MI 109 Compact Telephone connections

Mounting Cord		Connecting Block Designations			Inside Wiring Colors	
Lead Name	Color	NE-47QA or QBB1B	NE-283 74-5001 Adapter	NE-625F TELADAPT	Z Station Wire	16/25 Pair Cable
Audio T	G	G	1T	T1 (G)	G	W-BL
Audio R	R	R	1R	R1 (r)	R	BL-W
SIG T	BK	BK	XI	AUX (BK)	BK	w-o
SIG R	Y	Y	x2	GND (Y)	Y	o-w
AC1	BL	5	R	T2 (BL)		w-SL
AC1	W	6	B	R2 (W)		SL-W

Note: To prevent sending false signals to the CPU, connect and disconnect leads in the following sequence:

Connecting

- 1) Signal Pair (SIGT, SIGR)
- 2) Audio Pair (AUDT, AUDR)
- 3) Power Pair (AC1, AC1)

Disconnecting

- 1) Power Pair
- 2) Audio Pair
- 3) Signal Pair

Note 2: A 24V ac supply is required when the set is equipped with a digit display. QUS1C logic handsfree unit, QKK-type remote powering kit (for extended range), QMT1 or QMT2 key/lamp modules.

Note 3: 15V ac supply required when equipped with QMT3 lamp field array module. An extra 3-conductor cord kit is required.

Note 4: These supplies may be obtained from:

115/24V ac or 115/1 5V ac transformers located within 25 ft. (7.7 m) of the set (each set requires a separate transformer).

QUT1 or QJAA1 centralized power unit (each set requires a separate fuse to prevent noise or cross talk).

Figure 4-7
SL-1 Telephone and MI 109 Compact Telephone connections

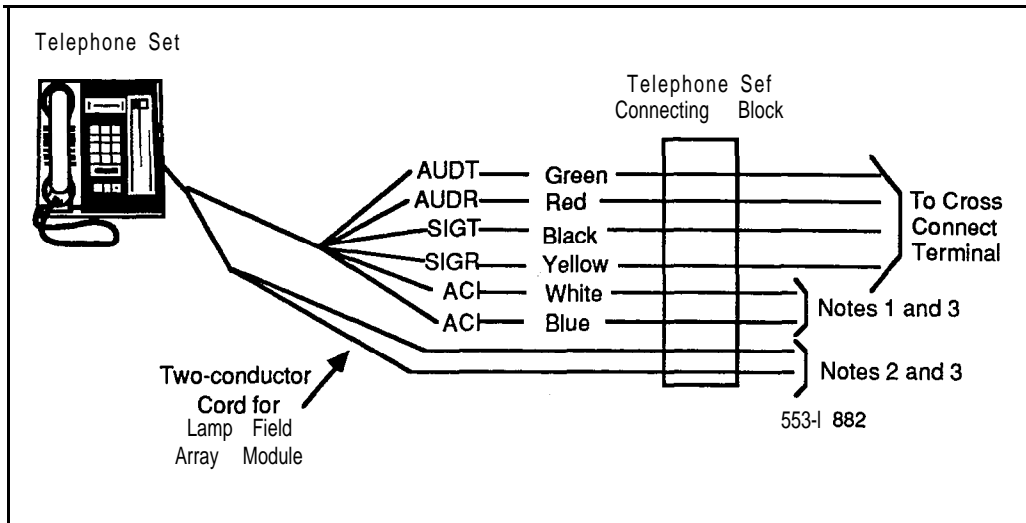

Procedure 4-14
Connecting 500/2500-type telephone sets

- 1 Ensure that the terminal connector is compatible with telephone set connector.
- 2 Connect telephone set mounting cord:
 TELADAPT cords (NE-625F connector) do not require terminations. Insert the plastic connector on the end of telephone set mounting cord into the **NE-625F** type receptacle.
- 3 Connect the mounting cord to an NE-284-74-5001 **amphenol** adapter if reusing **16-** or **25-pair** cable. Plug the adapter into the cable connector. Fasten the connector together with the screws provided at the end of each connector.

Table 4-2
NE-50012500 telephone set connections

Mounting Cord	NE-47QA or		Cable Color Pairs 16 to 25 not used	Connect to TN
	QBBIB Block Designation	NE-284-74-5001 Designation		
TIP (green)	G	1T	W-BL	TIP
RING (red)	R	1R	BL-W	RING
GND (yellow)	BK	x2		
	Y	XI		

Cross-connecting telephone sets

Be sure to connect the sets according to the following figures. Figure 4-8 provides the diagram for cross connecting **500/2500-type** telephone sets. SL-1 telephones' cross connections are shown in Figure 4-9, and the Meridian Modular telephone sets have the cross connections shown in Figure 4-10.

Procedure 4-15 **Cross-connecting telephone sets**

- 1 Locate telephone set terminations at cross-connect terminal.

Telephone set terminations are located on the vertical side of the frame (when frame mounted blocks are used) and in the blue field (when wall mounted blocks are used).
- 2 Connect Z-type cross-connecting wire to the leads of the telephone set.
- 3 Locate line circuit pack (TN) terminations.

Line circuit pack (TN) terminations are located on the horizontal side of the distributing frame when frame mounted blocks are used and in the white field when wall mounted blocks are used.

- 4 Run and connect the other end of the cross-connecting wire to the assigned TN terminal block.

Table 4-3
Type Z cross-connecting wire

Size	Gauge	Color	Designation
1 pr	24	Y-BL	Tip
		BL-Y	Ring
3 pr	24	W-BL	Voice T
		BL-W	Voice R
		w-o	Signal T
		o-w	Signal R
		W-G	Power
		G-W	Power

Table 4-4
Inside wiring colors

Z Station Wire	Inside Wiring Colors 16/25 pair cable	Connect to Equipment TN
G	W-BL	1 st pair Tip
R	BL-W	1 st pair Ring
BK	w-o	2nd pair Tip
Y	o-w	2nd pair Ring

Figure 4-8
NE-500/2500-type telephone set cross-connections

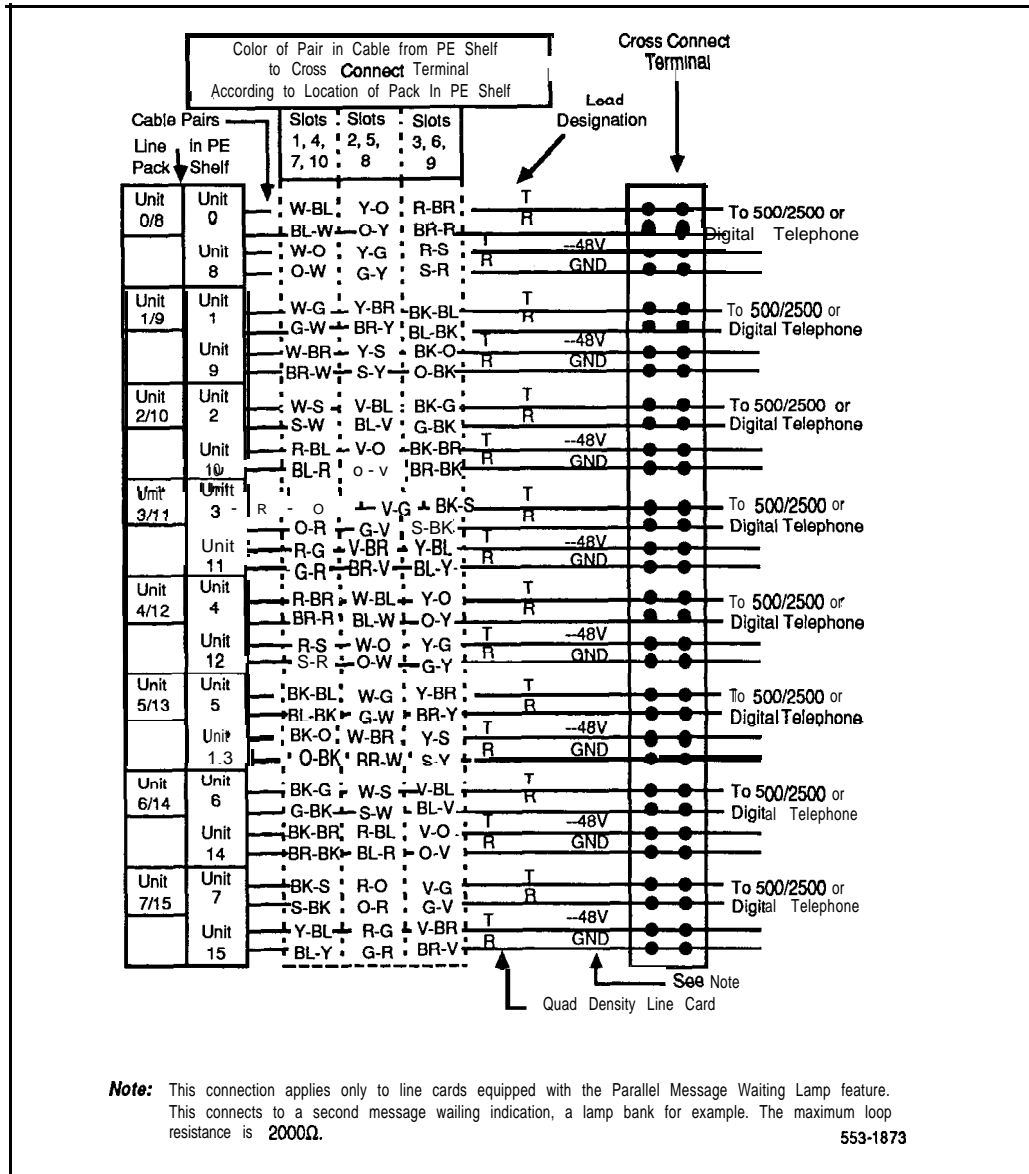

Figure 4-9
SL-1 Telephone cross-connections

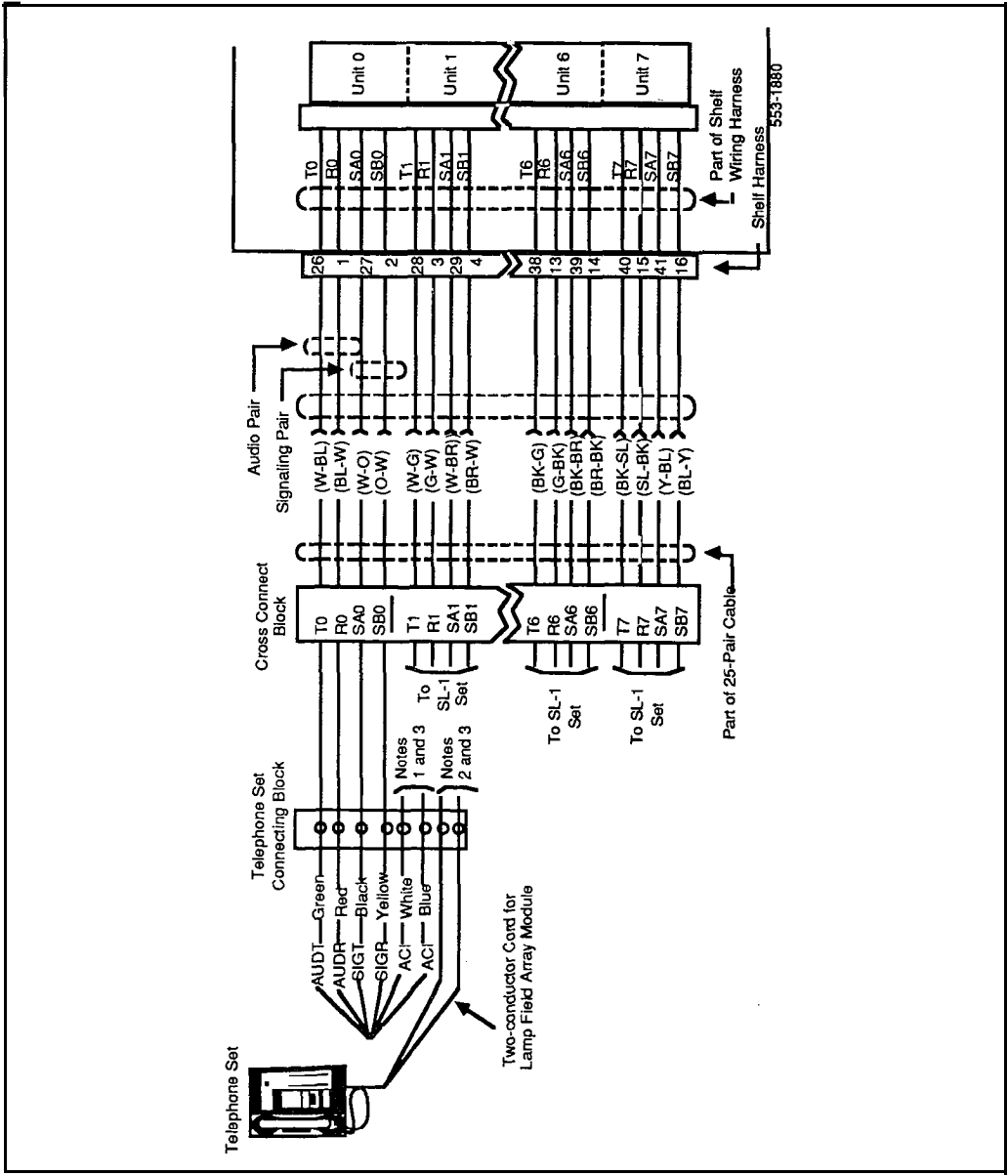
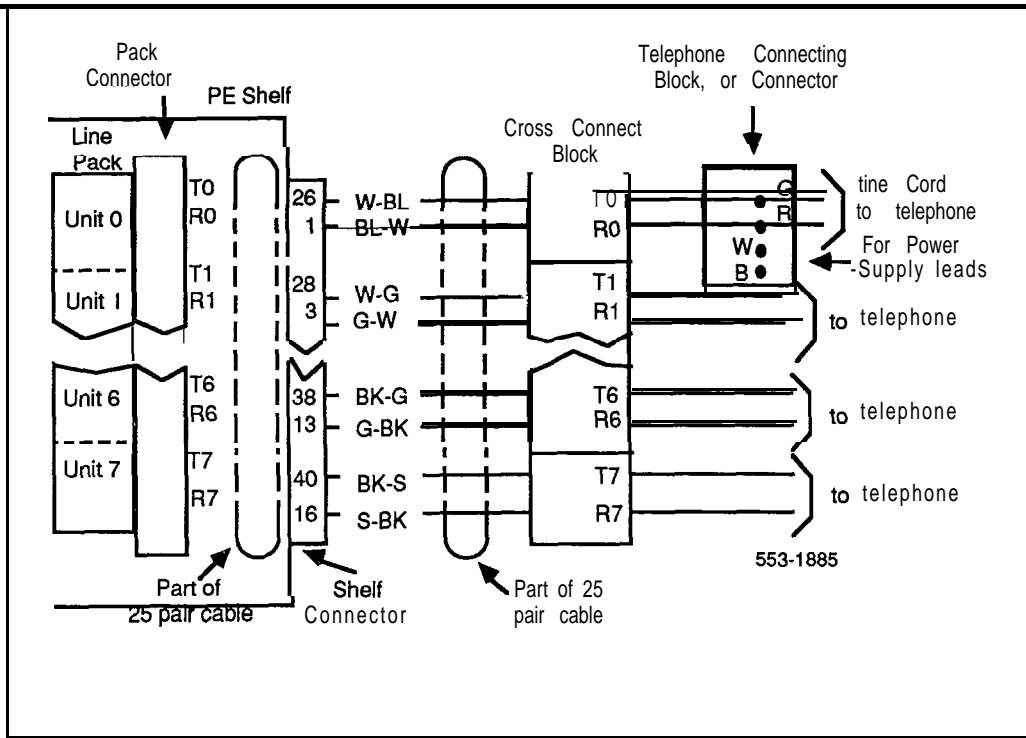

Figure 4-10
Meridian Modular Telephone cross-connections



Add-on modules

Packing and unpacking

Use proper care while unpacking any add-on module. Check for damaged containers so that appropriate claims can be made to the transport company for items damaged in transit.

If a module has to be returned to the factory, ensure that it is packed in the appropriate container to avoid damage during transit. Remember to include all loose parts in the shipment.

QMT1, QMT2 add-on module

The **QMT1** key/lamp module has 10 nonlocking keys and 8 LED, while the **QMT2** key/lamp module has **20** nonlocking keys and 16 LED. Add modules to the right side of an SL-1 telephone set or attendant console.

The SL-1 telephone set can have up to six additional key strips (for example, six **QMT1** modules, or two **QMT1** and two **QMT2** modules). However, the number of additional key strips that you can add may be limited by other equipment that is connected to the telephone set. A full description of equipment that can be added to an SL-1 telephone set, along with their limitations is described in *QSU telephone sets, add-on modules and interface kits—Description* (553-2001-1 10).

The QCW type attendant console accommodates one **QMT2** or two **QMT1** modules.

When the MI250 or M2250 attendant console is delivered from the factory, the **QMT2** option switch is OFF. To turn the switch ON, you must open the attendant console (see “Attendant consoles”, Procedure 3-5).

Each telephone set which has a key/lamp module installed requires a **25V** ac power supply.

Procedures 5-3 and 5-4 describe the connecting and disconnecting of add-on key modules. Tables 5-1 through 5-4 give switch settings for **the** various applications of add-on modules. Table 5-5 gives the jack numbering for add-on module connecting.

Faceplate

See Figure 5-1 as a reference for the removal and installation of the **QMT1** and **QMT2** add-on module faceplate.

Procedure 5-1

Installing **QMT1** and **QMT2** add-on module faceplate

- 1 Place the add-on module on a desk with the front edge slightly beyond the edge of the desk.
- 2 Fit the cover to the housing and tighten the captive retaining screws.
- 3 Position the faceplate so that the keys will pass through **the** cutouts in the faceplate.
- 4 Tilt the back edge of the faceplate towards the rear of the module, and insert the locating tabs into the slots on the attendant console cover.

-continued-

- 5 Keeping the locating tabs in the slots, tilt the front edge of the faceplate down, passing the keys through the cutouts in the faceplate.
- 6 Press the front edge of the faceplate down until the faceplate catches snap into place.
- 7 Ensure that the faceplate is securely held in place without binding the keys.

Procedure 5-2

Removing QMT1 and QMT2 add-on module faceplate

- 1 Place the add-on module on a desk with the front edge slightly beyond the edge of the desk.
- 2 Insert a paper clip into each release hole in the front edge of the module housing to release faceplate
- 3 Lift the faceplate off.
- 4 Unscrew the captive retaining screws securing the cover to the housing, and remove the cover.

Figure 5-1
QMT1 and QMT2 add-on module faceplate

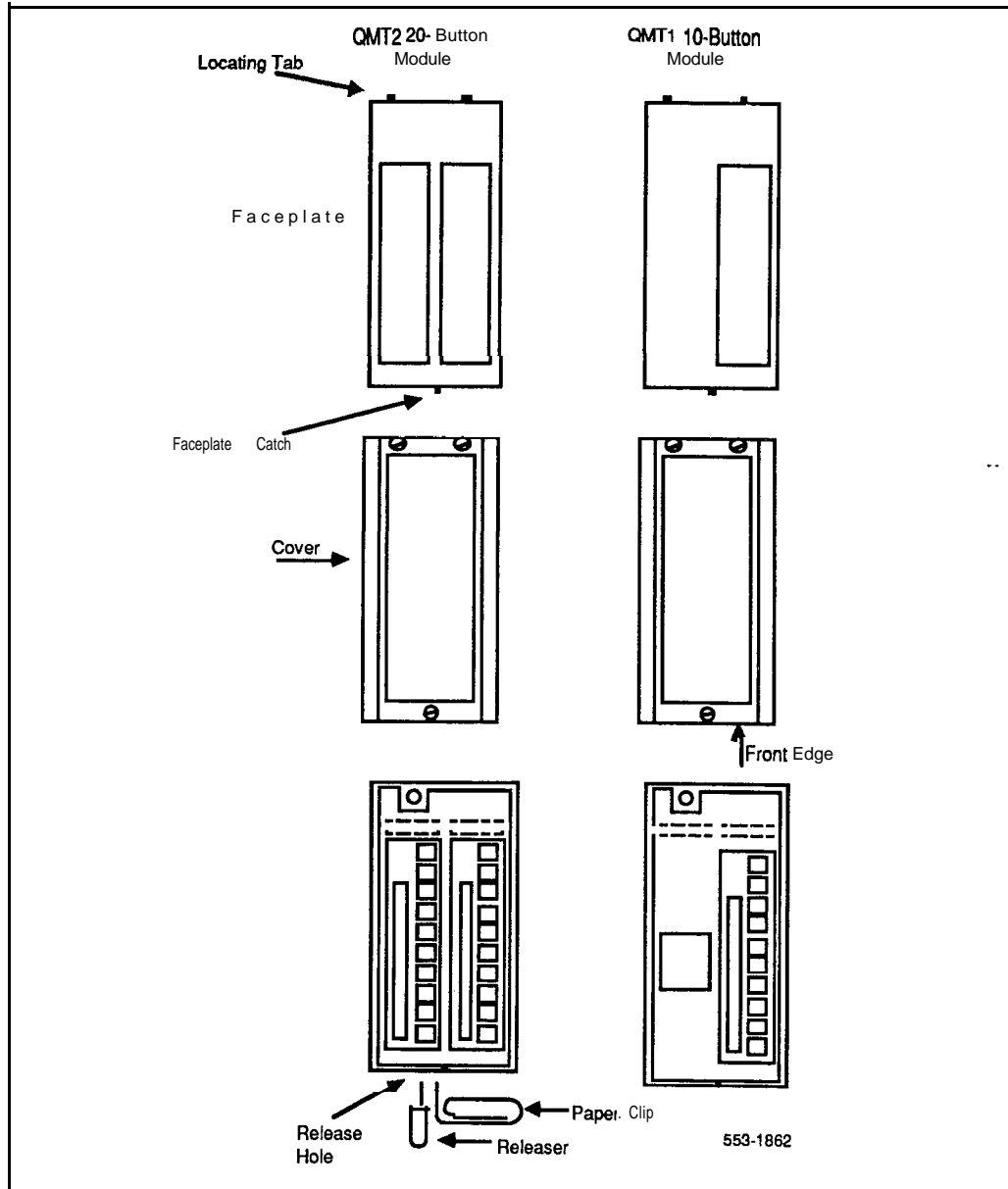

Procedure 5-3**Connecting QMT1 and QMT2 add-on module**

- 1 Verify that the address switches are correctly set.
- 2 Remove filler plate **from** right side of telephone set, attendant console or add-on module. Store filler plate.
- 3 Place the left side of the new module against the right side of the telephone set, attendant console or installed module, aligning the filler plate openings.
- 4 Lock the new module in place by inserting the locking device, attached to the wiring harness, over the edges of the filler plate openings.
- 5 Extend the module harness into the existing unit and insert the plug into the jack.

If the QMT2 module is of C vintage or earlier remove the screws securing the circuit board to the module housing and remove the circuit board. Insert the plug of the wiring harness into the connector and replace the circuit board and secure with screws.

- 6 Provide the 25V ac supply if this is the first module being added to an SL-1 telephone.

--

Procedure 5-4**Disconnecting QMT1 and QMT2 add-on module**

- 1 Remove data from system memory. Refer to *SL-1 XII input/output guide* (553-3001-400).
- 2 Remove the plug on the end of the module wiring harness, from the jack in adjacent unit.

If the QMT2 module is of C vintage or earlier, remove **the** screws securing the circuit board to the module housing.

- 3 Remove locking device, connecting the module to adjacent unit.
- 4 Locate stored filler plate and insert in filler plate opening.
- 5 Disconnect 25V ac supply if not required. '

Figure 5-2
Add-on module(s) connection to SL-1 Telephone

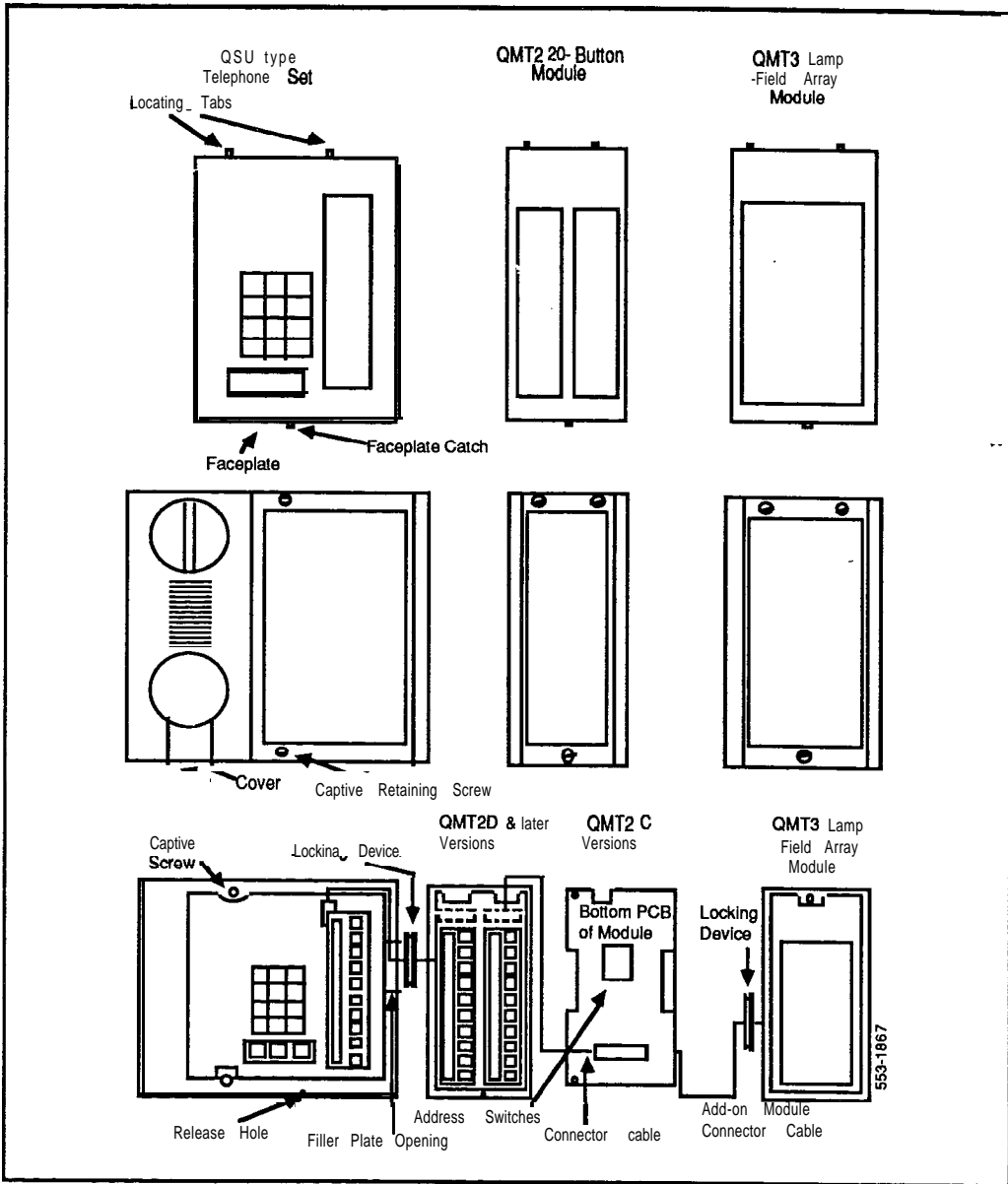

Figure 5-3
Add-on module(s) connection to attendant console

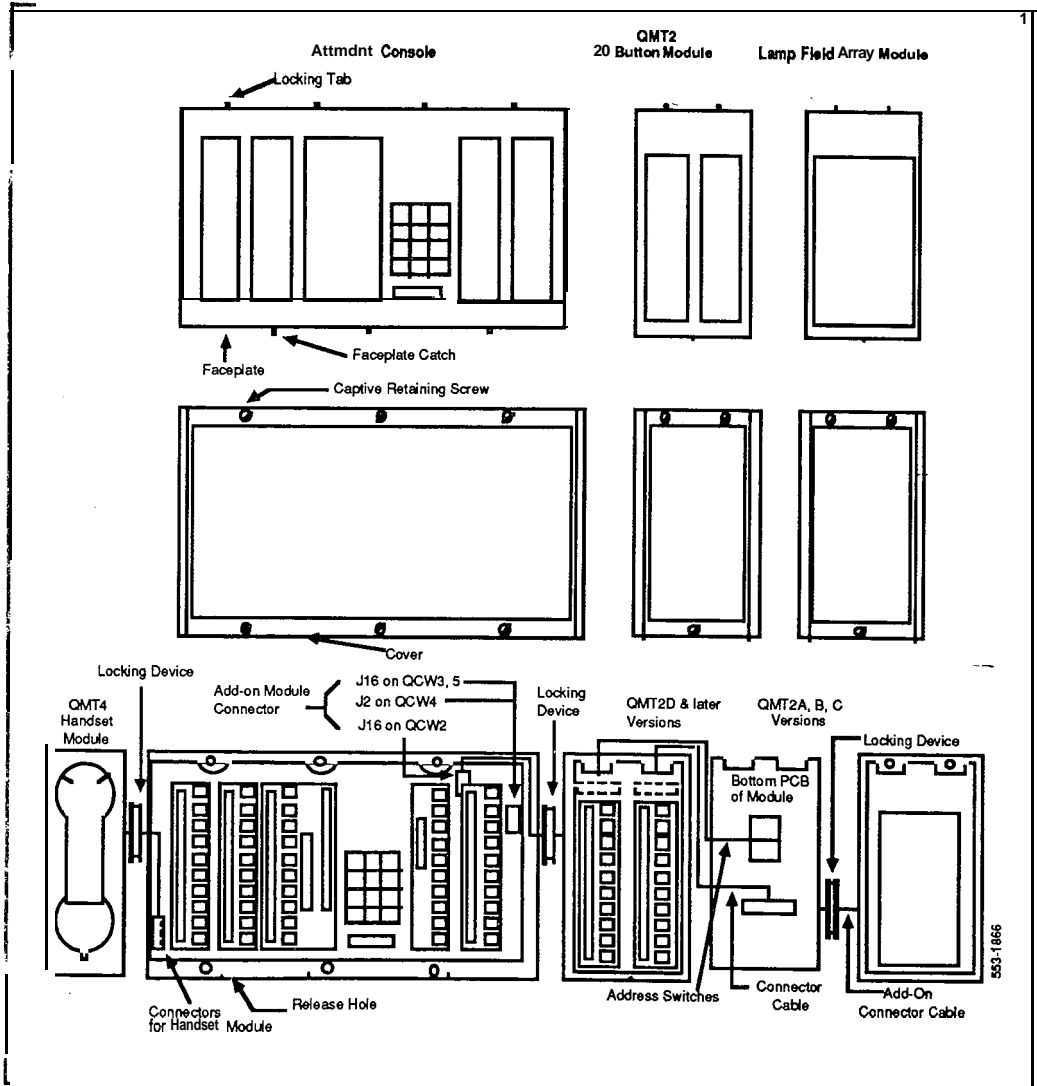

Table 5-1
QMT1 key/lamp module address switch settings (SL-1 Telephones)

Added Key/Lamp Strip Number (Note)	Address Switch Settings					
	1	2	3	4	5	6
1	0	0	X	0	0	0
2	0	X	0	0	0	0
3	0	X	X	0	0	0
4	X	0	0	0	0	0
5	X	0	X	0	0	0
6	X	X	0	0	0	0

Switch OFF = 0
Switch ON = X

Note: When a **QMT1** module is added to an SL-1 telephone, the address switch contained in the module must be set according to the corresponding strip number, e.g., the first module added is strip 1 and the second module added is strip 2, etc. The number of key strips that can be added to an SL-1 telephone varies from 4 to 6 key strips, depending on the type of other add-on modules or kits that are connected to the telephone set. Refer to 553-2001-1 10 for add-on module limitations.

Table 5-2

QMT2 key/lamp module address switch settings (SL-1 Telephones)

Added Key/Lamp Strip Number (Note)	Address Switch Settings					
	1	2	3	4	5	6
1,2	0	0	X	0	X	0
2,3	0	X	0	0	X	X
3,4	0	X	X	X	0	0
4,5	X	0	0	X	0	X
5,6	X	0	X	X	X	0

Switch OFF = 0
Switch ON = X

Note: When a QMT2 module is added to an SL-1 telephone, the address switch contained in the module must be set to the corresponding strip number, e.g., the first module added is strip 1 and 2 and the switch is set to address 1 and 2. If a **QMT1** precedes a QMT2, then the switch is set to address 2 and 3. The number of key strips that can be added to an SL-1 telephone varies from 4 to 6 key strips, depending on the type of other add-on modules or kits that are connected to the telephone set. Refer to 553-2001-I 10 for add-on module limitations.

Table 5-3

QMT1 module Address Switch settings (attendant consoles)

Added Key/Lamp Strip Number (Note)	Address Switch Settings					
	1	2	3	4	5	6
First module 4	X	0	0	0	0	0
Second module 5	X	0	X	0	0	0
Switch OFF = 0 Switch ON = X						
Note: Only two 1 O-key lamp strips may be added to an attendant console. The first strip added is assigned to address 4, the second to address 5.						

Table 5-4

QMT2 Module Address Switch settings (attendant console)

Added Key/Lamp Strip Number (Note)	Address Switch Settings					
	1	2	3	4	5	6
Strip 4 and 5	X	0	0	X	0	X
Switch OFF = 0 Switch ON = X						
Note: Only one QMT2 key/lamp strip can be added to an attendant console.						

Table 5-5
Jack numbering for add-on module connection

Equipment	Jack Number
SL-1 Telephones (Note	J1
SL-1 Telephone equipped with QKK3 kii	J2 of QKK3
QMT1 Add-on module	J2
QMT2C Add-on module	J1
QMT2D Add-on module	J2
QMT3 Add-on module	J6
QCW2, 3 and 5 Attendant consoles	J16
QCW4 Attendant console	J2

Note: On SL-1 telephones with a digit display, jack **J1** is extended to the connector located beside the right-hand filler plate.

**

Designating add-on modules

Be sure to refer to the work order for features enabled, and key designations. Refer to ***QSU-Telephone sets, add-on modules, interface-kits and M1000 series telephones description*** (553-2001-110) for SL-1 sets' add-on module limitations.

Procedure 5-5 Designating Add-on modules

- 1 Remove cap, by gently pulling upwards, **from** each key requiring a designation.
- 2 Remove appropriate designation from sheet of designations.
- 3 Place designation in cap, place cap over corresponding key and gently press down. Repeat for all keys requiring designations.
- 4 Insert a paper clip into the hole at left or right end of designation window, and gently pry open the window.
- 5 Insert number tag, and replace the designation window.

QMT3 Lamp Field Array

The addition of a **QMT3** Lamp Field Array on an SL- 1 telephone reduces the number of add-on modules that may be equipped on the telephone set. Refer to ***QSU-Telephone sets, add-on modules, interface kits and M1000 series telephones description*** (553-2001-1 10) for a full description of the types and limitations of add-on modules that may be added to an SL- 1 telephone.

Refer to ***Attendant consoles and add-on modules description*** (553-2001-1 15) for a description of QCW type attendant consoles equipped with a **QMT3** Lamp Field Array. See also "Busy Lamp Field/Console Graphics Module" for installation of LFA on M1250 and **M2250** attendant consoles.

The **QMT3** Lamp Field Array (**LFA**) module is added to the right-hand side of the attendant console or SL-1 telephone. It can be used with any combination of **10-** or **20-key** modules and requires a separate **15V** ac power supply.

The **QMT3** module should be installed at the extreme right of the attendant console or other add-on modules, to avoid disassembling the **QMT3** module to gain access to its connector.

The Lamp Field Array module obtains its power through the attendant console. The requirements are:

- a reference ground line (OV)
- **5V** to power the CMOS electronics which control the Lamp Field Array module (c. 50 **mA**)
- power source of **—12V** for the display of the Lamp Field Array module (c. 10 **mA**)
- backlighting power

The Lamp Field Array module mounts on the back of the attendant console and is held on using **snapfits** and two screws.

Procedure 5-6**Connecting QMT3 module to an SL-1 telephone set or a QCW attendant console**

- 1 Unpack and inspect the Lamp Field Array (LFA) for damage. If it is damaged, notify your supplier.
- 2 Remove the faceplate and cover from the attendant console or from the SL-1 telephone, and from any add-on module that is connected to the right-hand side of the attendant console or telephone set.
- 3 Disconnect the switchhook cable connector from the PCB of the telephone set.
If you are adding the LFA to a QSU3 or QSUIF (and later vintage) telephone sets, go to step 7.
- 4 Remove the LED strip and cable connector from the telephone set.
- 5 Remove the four (4) dial pad retaining screws. Remove the dial pad cable connector from the PCB.
- 6 Remove the retaining screws at the top and bottom of the PCB. Remove PCB from telephone set.
If you are adding the LFA to a QSU1C through QSUIE vintage telephone set, go to step 8.
- 7 (for pre-QSU3D vintage SL-1 telephones) Remove the retaining screws from around the dial pad and remove the dial pad.
Note: Some dial pads are soldered to the PCB and cannot be disconnected.
- 8 Remove the retaining screws from the PCB and remove the PCB.
- 9 Install a 2-conductor power cord (with spade-tip connectors) through the base of the telephone set alongside the existing line cord. Secure the power cord to the line cord with plastic cable tie.

—continued—

- 10 Replace the PCB and secure **with** retaining screws.
- 11 Connect the two leads of the power cord to the AC2 quick-connect terminals.
- 12 Replace the dial pad (if necessary) and secure **with** retaining screws.
- 13 Remove the filler plate from the right side of the set (or right-most **add-on** module).
- 14 Lock the LFA to the set (or attached add-on module) by slipping the locking device on the LFA wiring harness over the edges of the filler plate opening. Connect the LFA wiring harness to the jack on the telephone set (or attached add-on module).
- 15 Reconnect the switchhook cable connector. Reconnect the LED strip (if necessary) and secure with retaining screws.
- 16 Cross-connect (at the main cross-connect terminal or the intermediate cross-connect point) 15V ac from the power unit to the attendant console or telephone set.
- 17 Reattach **the** faceplate and cover to the attendant console or SL-1 telephone and the add-on module.
- 18 Configure the QMT3 in the system. Refer to **SL-1 X11 input/output guide** (553-3001-400).

Procedure 5-7
Connecting QMT3 module to M1250/M2250 attendant console

- 1 Disconnect the main power from the attendant console.
- 2 Remove the **attendant** console from the **adjustable stand**, if it is mounted on one.
- 3 Remove the faceplate of the attendant console (see Procedure 3-4).
- 4 Remove the knock-out section on the back of the attendant console base, using a screwdriver or a small hobby knife, and clean away the small tabs around the edges.
- 5 Place two screws part-way into the attendant console, leaving 6 to 9 mm protruding (about two turns each).
- 6 Feed the flat ribbon cable from the Lamp Field Array through the hole in the base cover of the attendant console.
- 7 Fit the top cover PCB into the flexible strip connector plug **J4**.
- 8 Fit the Lamp Field Array module onto the attendant console base. (It snaps in.)
- 9 Install the faceplate on the attendant console (see Procedure 3-5).
- 10 Tighten the two screws that secure the support bracket to the **attendant** console.
- 11 Reconnect the main power to the attendant console.
- 12 If the lamp field array module has been properly installed, the main menu appears.
- 13 To test the lamp field array, select one of the displayed options.

Refer to the **M1250 Attendant Console User Guide** (PO699329) or **M2250 Attendant Console User Guide** (PO704329) for further information.

Procedure 5-8

Disconnecting QMT3 module from an SL-1 set or QCW attendant console

- 1 Remove lamp field array data from the system memory. Refer to *SL-1 X11 input/output guide* (553-3001-400).
- 2 Remove **the** faceplate and cover from the attendant console or the SL- 1 telephone and from the any add-on module connected to **the** right-hand side of the telephone.
- 3 Disconnect the lamp field array module.
- 4 Reattach the cover and faceplate on the set or attendant console, and on the add-on module.
- 5 Pack the Lamp Field Array module in a container.
- 6 Test the SL-1 telephone or attendant console. Refer to *Acceptance test manual* (553-2YY1-230).

Procedure 5-9

Disconnecting the QMT3 module from M1250/M2250 attendant console

- 1 Disconnect the main power from the attendant console.
- 2 Loosen the two screws that secure **the** support bracket to the attendant console, and remove the faceplate from the attendant console
- 4 Pull the lamp field array module from the attendant console base.
- 5 Remove the flat cable from the top cover PCB, flexible strip connector J4. Pull the cable through **the** hole in the attendant console base.
- 6 Remove two screws from the attendant console.
- 7 Put the faceplate back on the attendant console.
- 8 Reconnect the main power cable to the attendant console.
- 9 Put the attendant console back onto the adjustable stand, if it has one,

Table 5-6

Jack numbering for QMT3 module connection

Equipment	Jack Number
SL-1 Sets (Note)	J1
SL-1 Set equipped with QKK3 kit	J2 of QKK3
QMT1 add-on module	J2
QMT2C add-on module	J1
QMT2D add-on module	J2
QMT3 add-on module	J6
QCW2, 3 and 5 attendant consoles	J16
QCW4 attendant console	J2

Note: On sets with a digit display, jack **J1** is extended to the connector located beside the right-hand filler plate. **

Figure 5-4
QMT3 Lamp Field Array connections to attendant console

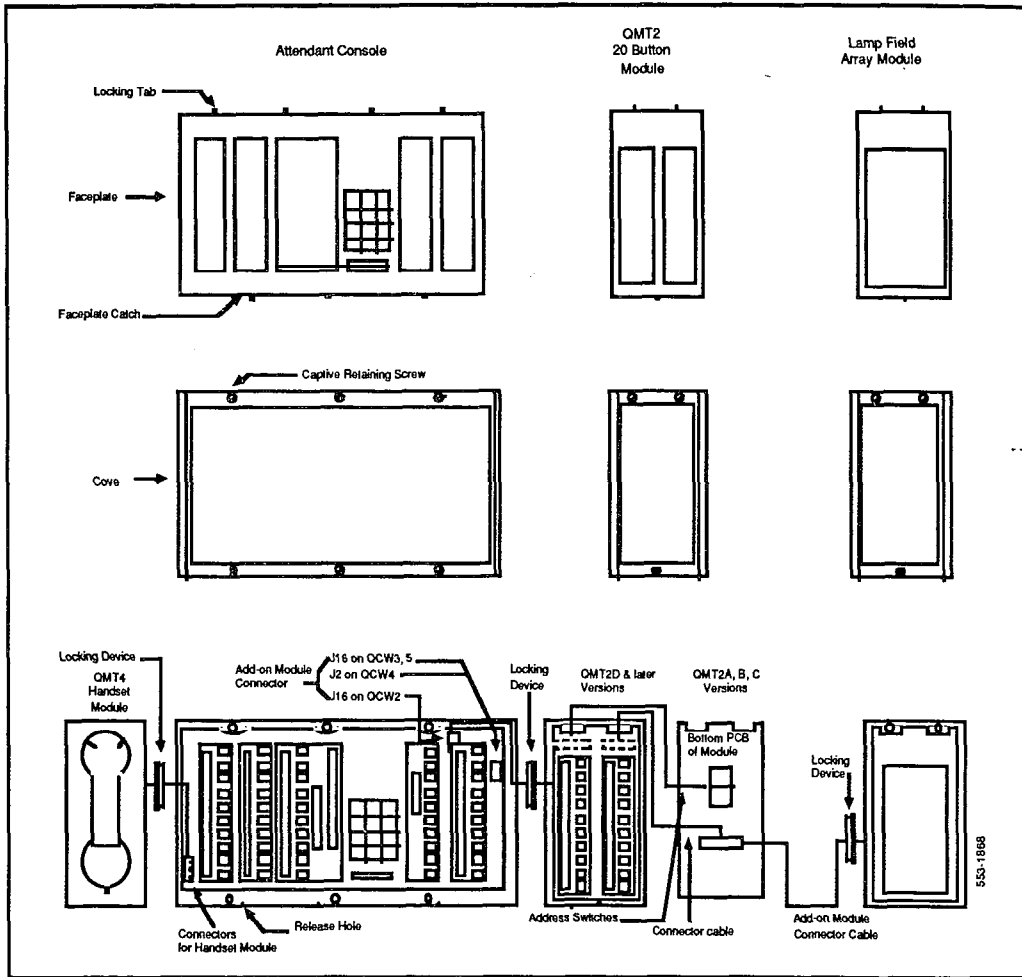
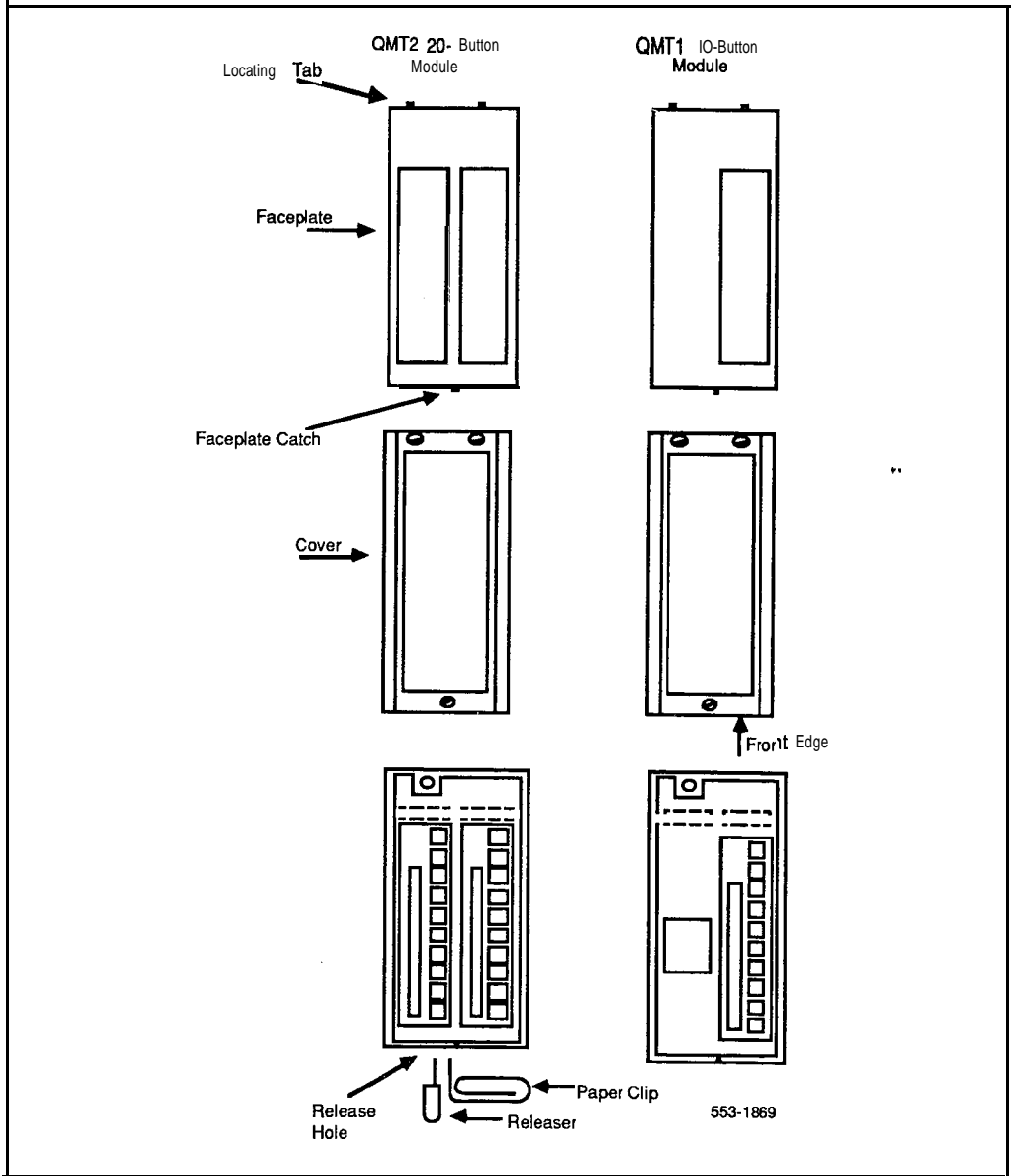

Figure 5-5
QMT3 Lamp Field Array connections to SL-1 Telephone



Busy Lamp Field/Console Graphics Module

The Busy Lamp Field/Console Graphics Module obtains its power through the attendant console. The requirements are:

- a reference ground line (OV)
- power source of **5V** for the CMOS electronics which control the lamp field array module (c. 50 mA)
- power source of **—12V** for the display of the Console Graphics Module (c. 10 mA)
- backlighting power

An external floating 16V dc (300 mA) power supply is required to be cabled in at the local MDF at a maximum of 115 feet (35 m) from the attendant console when the BLFKGM is installed (A0367601—Transformer). This provides all power requirements for the M2250 applications, and for backlighting support on the M1250. Basic functionality is supported on the M1250 without the power supply.

The BLF/CGM has a battery that provides backup power to maintain the Supplementary Information when the console is powered down. Battery lifetime is five years. To replace the battery, return the BLF/CGM to your supplier.

The BLF/CGM mounts on the back of the attendant console and is held on using **snafits** and two screws.

The attendant console's top cover must be removed to install the Busy Lamp Field/Console Graphics Module (BLF/CGM).

Refer to *M1250 Attendant Console User Guide* (PO699329), *M2250 Attendant Console User Guide* (PO704329) or *Busy Lamp Field/Console Graphics Module User Guide* (PO706875) for further information. Refer to *M1250 and M2250 attendant consoles description* (553-2201-1 17) for a description of M1250, and M2250 attendant consoles equipped with a Busy Lamp Field/Console Graphics Module (BLFKGM).

Follow normal anti-static precautions when installing the BLF/CGM onto the attendant console.

Figure 5-6
Busy Lamp Field/Console Graphics Module on the M1250/M2250 attendant console

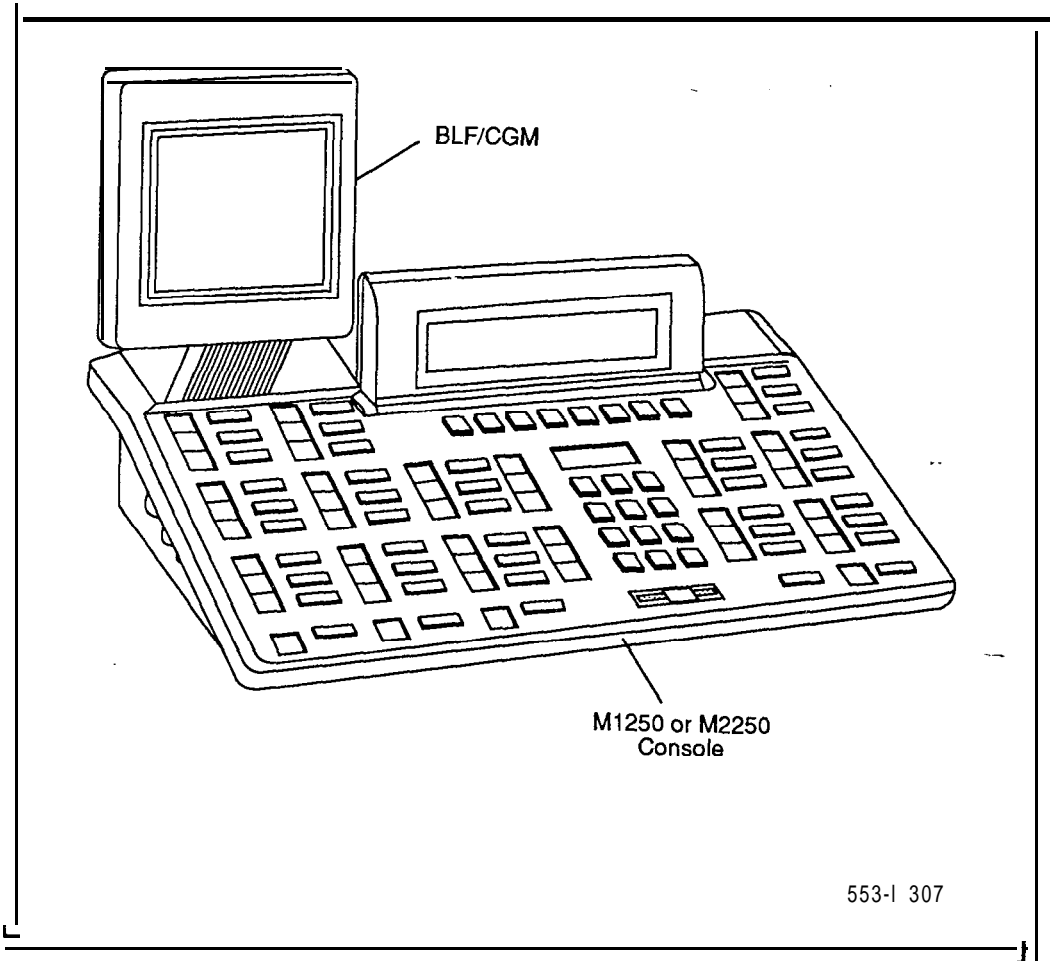

553-I 307

Procedure 5-1 0
Connecting the BLF/CGM to MI 250 and M2250 attendant consoles

- 1 Disconnect the **main** power/system cable from the rear of the attendant console, and remove the handset **jackplug** from the side.
- 2 Move adjustable display to down position to protect it from 'damage while installing the **BLF/CGM**. Also move the volume slider switch to the far left (see Figure 5-7).

Figure 57
Volume slider position

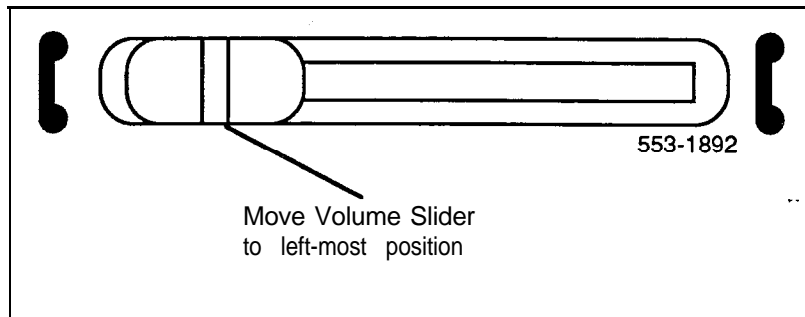

- 3 Place the attendant console face-down on a properly prepared work surface, taking care to avoid scratching or damaging the top cover or Display. Remove the adjustable stand, if required.
The stand is secured with four screws. Remove the stand as a complete assembly, and set aside.
- 4 Remove the twelve fastening screws in the base of the attendant console that secure the top cover to the console base (see Figure 5-8). Holding the console base and cover firmly, turn it back over so that the top cover is on, facing up.

-continued-

- 5 For M1250 Attendant Consoles, raise and hold the top cover to disconnect the two flat cable connectors as well as **the** alerter cable connector from the bottom PCB (see Figure 5-9).

For the **M2250** Attendant Console, raise and hold the top cover to remove the single cable connector only. The **alerter** cable does not need to be removed (see Figure 5-9).

- 6 Remove the top cover and place it upside down to the left of the attendant console.

—continued—

Figure 5-8
Removing the fastening screws

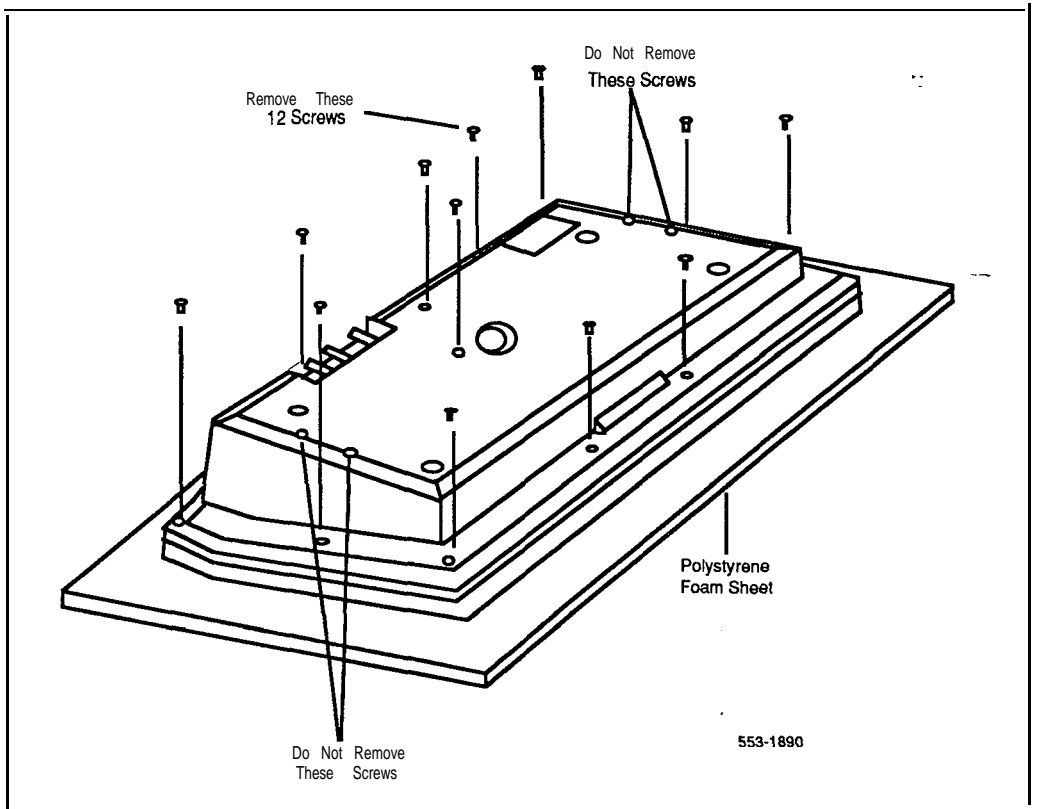
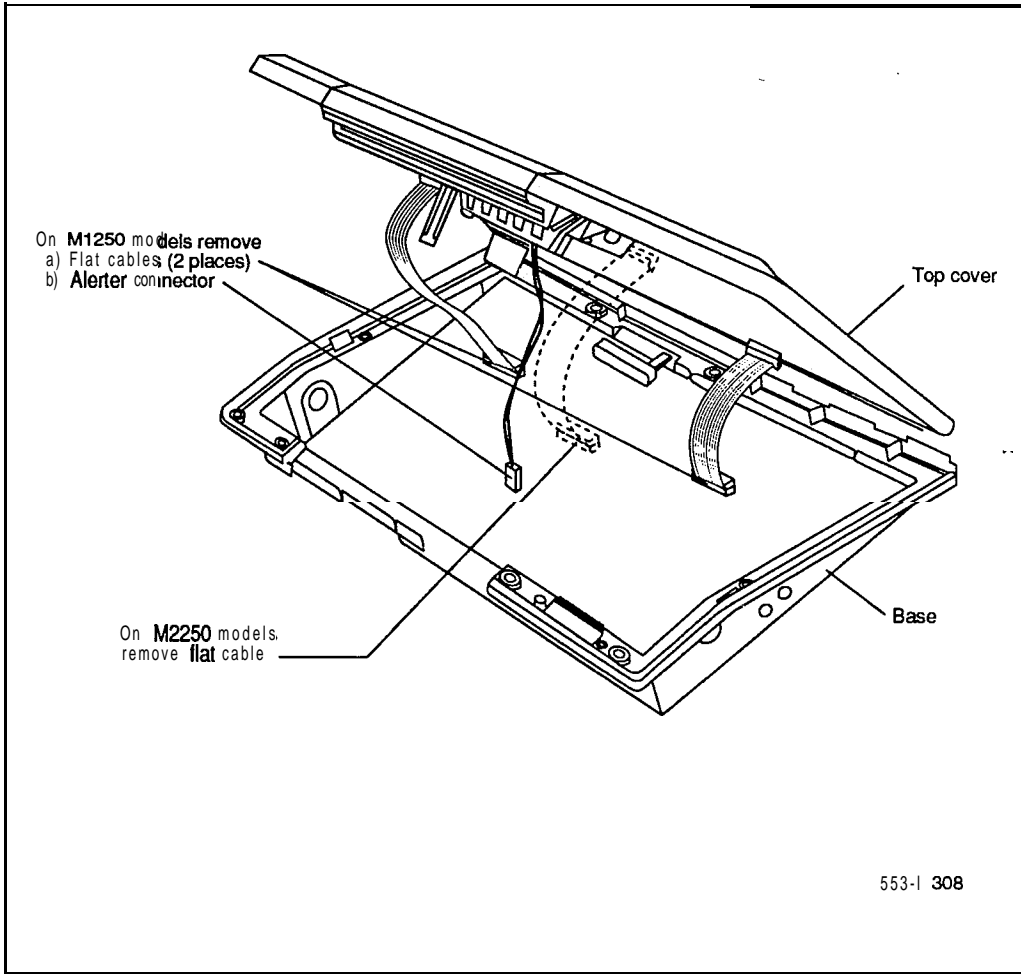
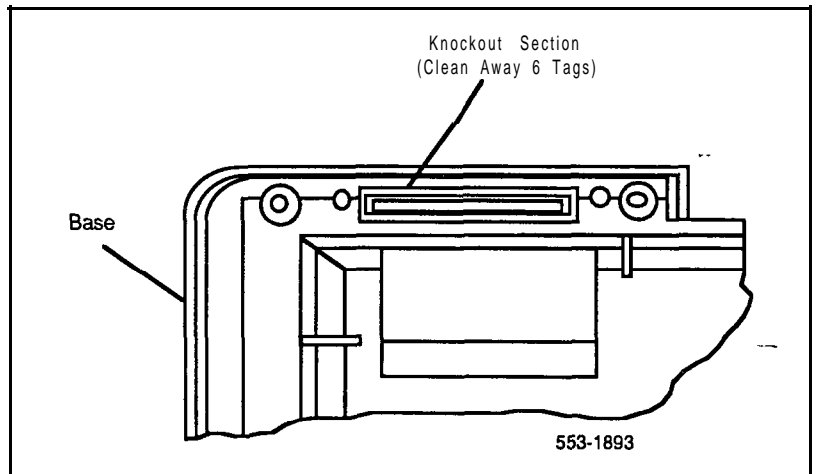

Figure 5-9
Removing the top cover



- 7 Remove the knockout section on the back of the attendant console (see Figure 5-10) with a small screwdriver or similar tool. Remove any remnants of the breakaway tags.
- 8 Feed the flat ribbon cable for the **BLF/CGM** through knockout hole in the base of the attendant console.
- 9 Hold the **BLF/CGM** unit over the console in a vertical position, ensuring that the two locators on the bottom bracket of the **BLF/CGM** are located in the knockout hole.

Figure 5-10
Attendant console knockout section



- 10 Push down on the attendant console, while holding the **BLF/CGM** unit, until the two locators snap into place (see Figure S-11).
- 11 Fit the **BLF/CGM** ribbon cable onto the top cover circuit board, into flexible strip connector J4 (so the blue line on the cable faces the circuit board).

—continued—

Figure 5-1 1
Connectina the **BLF/CGM** to the attendant console

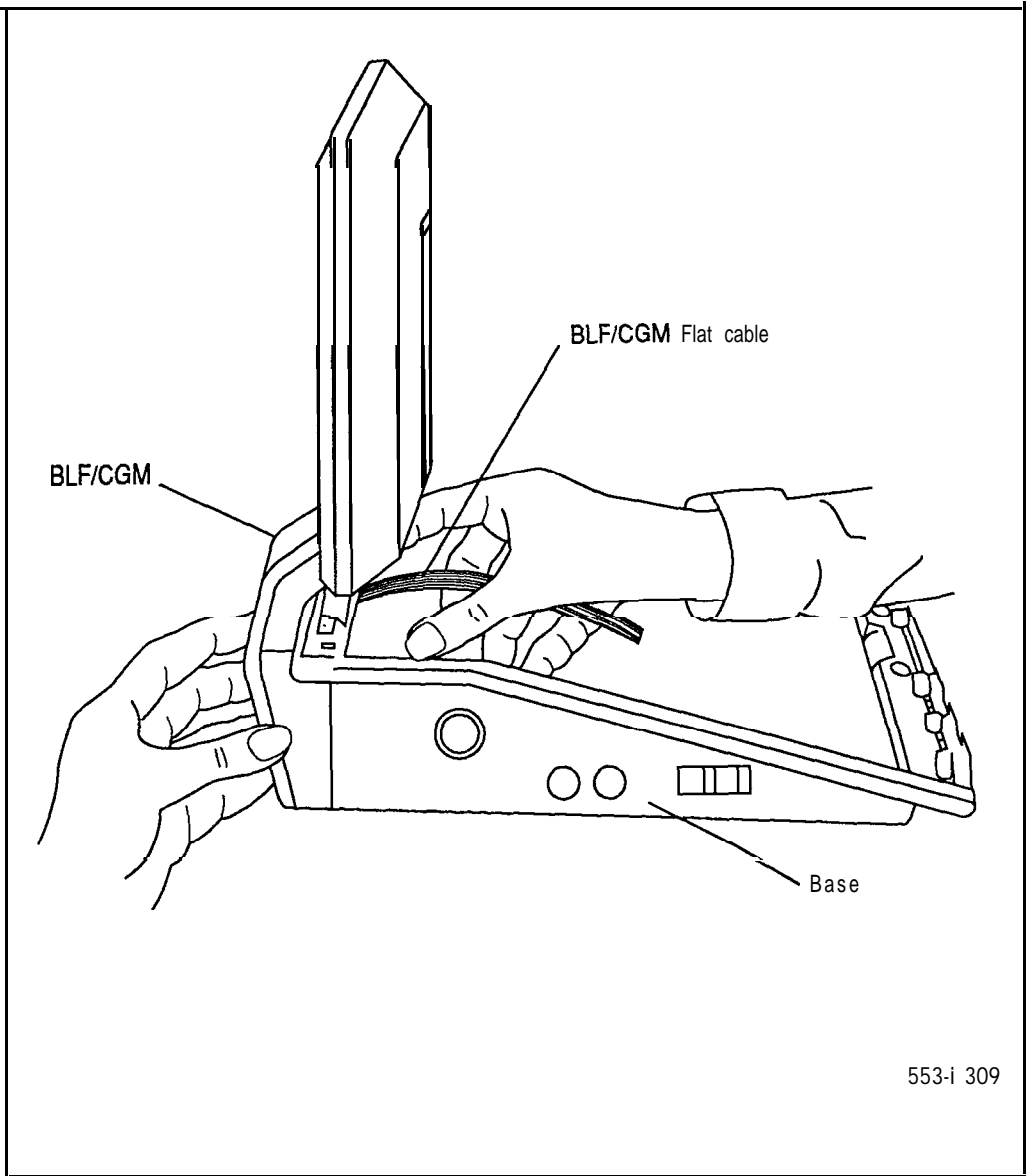

553-i 309

- 12 Hold the top cover over the attendant console and reconnect the cable connector(s) onto the base of the attendant console.

(M1250) Reconnect the alerter cable. Ensure that the protrusion on the support spacer is located in the correct slot on the console (see Figure 5-12).
- 13 Place the top cover on the console. Slide it back and down into place (see Figure 5-13). Check that all the cables are in the correct positions, and that none are trapped.
- 14 Push the **BLF/CGM** display into position by rotating it back (see Figure 5-13).
- 15 Ensuring that the volume slider is fully engaged in the correct slider, hold the top cover and console base firmly together. Turn the assembly upside down (see Figure 5-14).
- 16 Reinsert the twelve screws that secure the top cover to the console base and tighten.
- 17 Insert the two new screws supplied with the **BLF/CGM** that attach it to the base, and tighten (see Figure 5-7).
- 18 Cable in BLF power at local MDF as per M1250, M2250 cross-connections (see Procedure 3-8).
- 19 If required, replace the adjustable stand.
- 20 Re-connect the main system cable to the rear of the console.
- 21 If the **BLF/CGM** has been correctly installed, the main menu appears when you supply power to the attendant console. Test the **BLF/CGM** by selecting a menu option. Refer *to Busy Lamp Field/Console Graphics Module User Guide (P0706875)* for programming information.
- 22 Define the Busy Lamp Field in system data base. Refer to *SL-1 XII input/output guide (553-3001-400)*.
- 23 Test the Busy Lamp Field features using *M1250 Attendant Console User Guide (PO699329)* or *M2250 Attendant Console User Guide (PO704329)*.

Figure 5-12
Support spacer

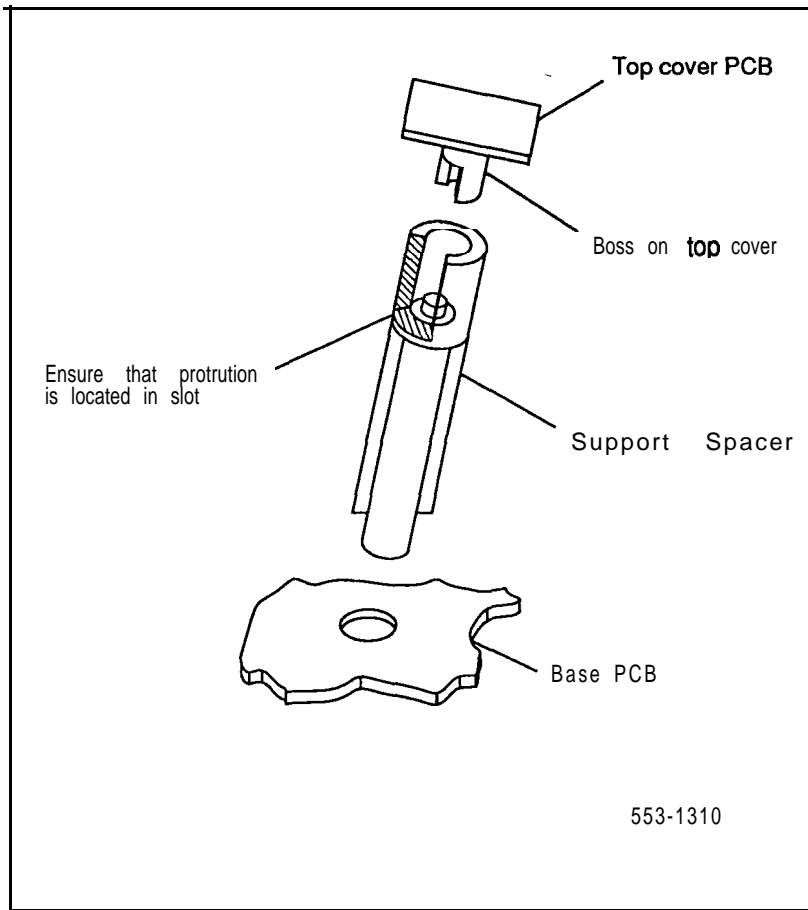

Figure 5-13
Positioning the top cover and BLF/CGM

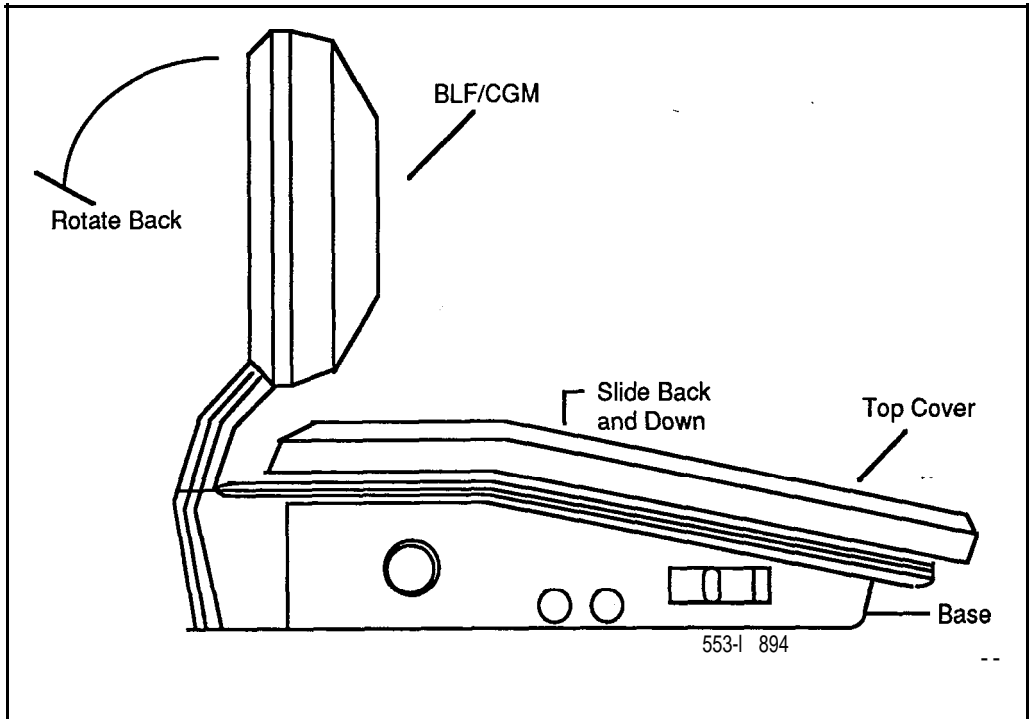
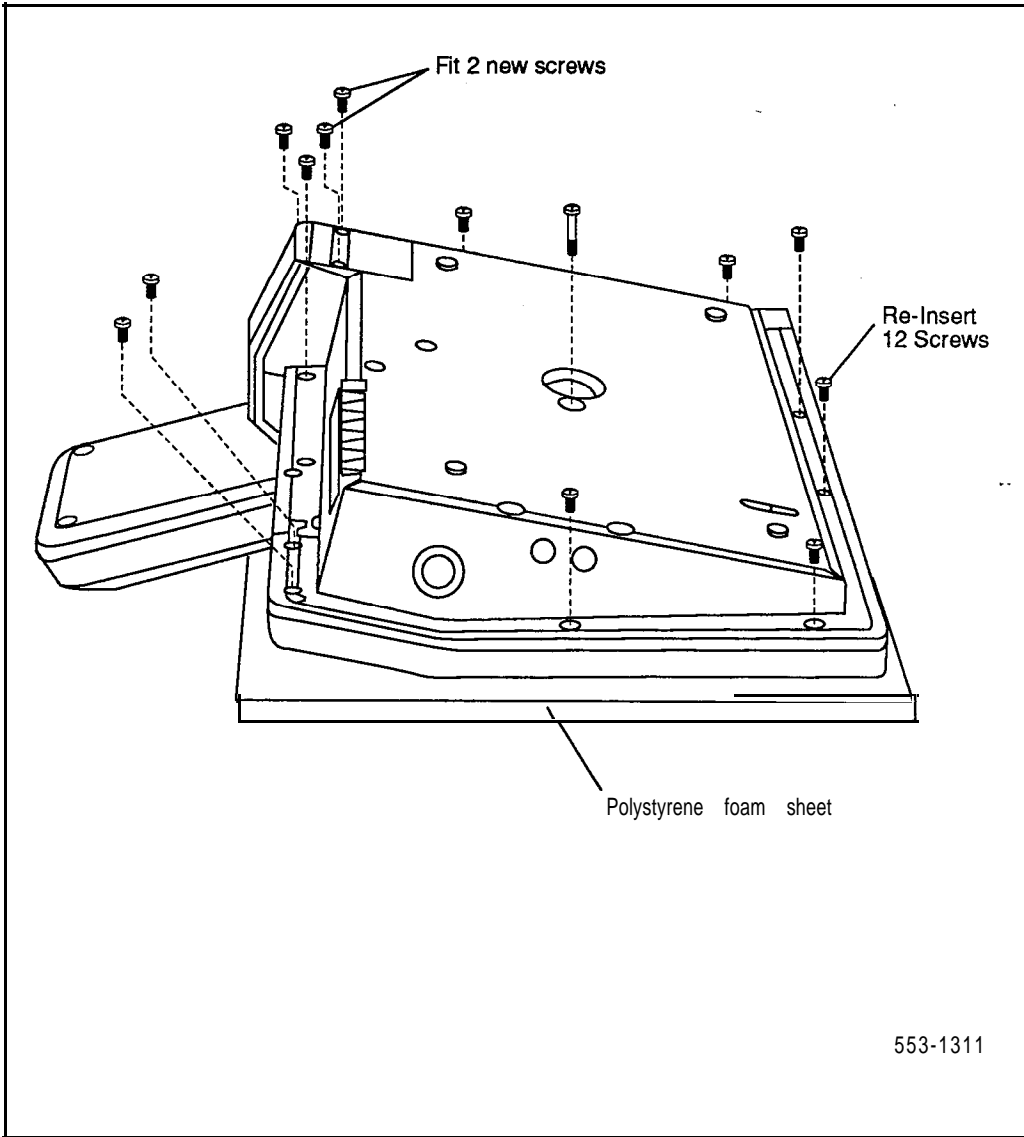

Figure 5-14
Attaching the top cover to the attendant console base and BLF/CGM



Procedure 5-I 1 Removing the Busy Lamp Field/Console Graphics Module

- 1 Disconnect the main power/system cable from the rear of the attendant console, and remove the handset **jackplug from the side**.
- 2 Move adjustable display to down position to protect it from damage while removing the **BLF/CGM**. Also move the volume slider switch to the far left (see Figure 5-7).
- 3 Place the attendant console face-down on a properly prepared work surface, taking care to avoid scratching or damaging the top cover or Display. Remove the adjustable stand, if required.

The stand is secured with four screws. Remove the stand as a complete assembly, and set aside.
- 4 Remove the twelve fastening screws in the base of the attendant console that secure the top cover to the console base (see Figure 5-8).

Remove the two screws securing the **BLF/CGM** to the base of the attendant console.
- 5 Holding the console base and cover **firmly**, turn it back over so that the top cover is on, facing up.
- 6 For M1250 Attendant Consoles, raise and hold the top cover to -- disconnect the two flat cable connectors as well as the alerter cable connector from the bottom PCB (see Figure 5-9).

For the M2250 Attendant Console, raise and hold the top cover to remove the single cable connector only. The alerter cable does not need to be removed (see Figure 5-9).
- 7 Unplug the **BLF/CGM** ribbon cable from the attendant console.
- 8 Remove the top cover and place it upside down to the left of the attendant console.
- 9 Pull back the snap-fits on the **BLF/CGM** to disengage the **BLF/CGM** from the attendant console.
- 10 Place the top cover on the console. Slide it back and down into place (see Figure 5-13). Reconnect all cables in the correct positions, and make sure that none are trapped.

—continued—

- 11 Ensuring that the volume slider is fully engaged in the correct slider, hold the top cover and console base firmly together. Turn the assembly upside down (see Figure 5-14).
- 12 Reinsert the twelve screws that secure the top cover to the console base and tighten.
- 13 If required, replace the adjustable stand.
- 14 Reconnect the main system cable to the rear of the console.

QMT4, QMT15 handset modules-

The following procedures describe the installation and removal of QMT4 and QMT15 handset modules:

- Procedure 5-12 explains how to connect **QMT4A** or B handset modules to a **QCW2**, **QCW3** or **QCW4** (or one of earlier vintage) attendant consoles.
- Procedure 5-13 explains how to disconnect **QMT4A** and B handset modules.
- Procedure 5-14 explains how to connect **QMT4C** handset modules to all types of attendant consoles.
- Procedure 5-15 explains how to connect **QMT15** amplified handset modules to **QCW4E** and later vintages of attendant consoles.
- Procedure 5-16 explains how to disconnect a **QMT15** amplified handset module from **QCW4E** (and later vintages) of attendant consoles and the disconnecting of **QMT4C** handset modules.
- Procedure 5-17 explains how to connect **QMT15** amplified handset modules to **QCW2**, **QCW3** and **QCW4D** (and earlier vintages) attendant consoles.
- Procedure 5-18 explains how to disconnect **QMT15** amplified handset modules from **QCW2**, **QCW3** and **QCW4D** (or earlier vintages) of attendant consoles.

The QMT4 A/B handset module can be attached to the left side of the attendant console or left free standing. The QMT4 A/B handset module cannot be connected to the **QCW4E** attendant console.

The **QMT4C** can be installed on all attendant consoles.

The **QMT15** amplified handset module cannot be installed on **QCW4E** (and earlier) attendant consoles equipped with a **QMT3** Lamp Field Array (**LFA**) module.

The **QMT15** module cannot be installed on **QCW2**, **QCW3**, or **QCW4D** (and earlier) attendant consoles equipped with a **QMT3** Lamp Field Array module.

Procedure 5-12

**Connecting Handset Module QMT4 A/B on a QCW2, QCW3 or QCW4D
(or earlier vintage) attendant console**

- 1 Unplug handset from attendant console.
- 2 Disengage the first LED strip on the left side of the attendant console by loosening the retaining clips at each end of the LED strip (QCW2 only).
- 3 Remove the filler plate from the right side of the handset module and the left side of the attendant console. Store filler plates.
- 4 Place the right side of the handset module against the left side of the attendant console aligning the filler plate openings.
- 5 Lock the module to the attendant console by inserting the plug adapter into the filler plate opening.
- 6 Insert the module wiring harness through the plug adapter into the attendant console.
- 7 In the attendant console, disconnect the six leads connecting the handset jacks to the Printed Circuit Board (PCB). Insulate and store the six leads.
- 8 Connect the six leads of the module wiring harness to the attendant console PCB.
- 9 (for QCW2 only) Replace the LED strip and secure with the two retaining clips.
- 10 Plug handset into jacks on left side of handset module.

Procedure 5-13
Disconnecting Handset module QMT4 A/B

- 1 Disengage the first LED strip on the left side of the attendant console by loosening the retaining clips at each end of the LED strip (**QCW2** only).
 - 2 In the attendant console, disconnect the six leads of the handset **module** wiring harness from the PCB.
 - 3 Locate the six insulated handset jack **leads** stored in the attendant console base.
 - 4 Remove the tape from the ends of the leads and connect the leads to the PCB.
 - 5 Unlock the handset module from the attendant console by removing the plug adapter from the filler plate.
 - 6 Install a filler plate in the filler plate opening on the attendant console.
 - 7 Reinstall the LED strip and secure it with the two retaining clips (**QCW2** only).
 - 8 Plug the handset into the handset jacks on the lower left side of the attendant console.
-

Procedure 5-14
Disconnecting QMT4C handset module

- 1 Unplug handset **from** attendant console.
- 2 Insert plugs on right side of **QMT4C** into jacks on left side of attendant console.
- 3 Plug handset into left side of handset module.

Figure 5-15
QMT4 A/B handset module attached and connected to attendant console

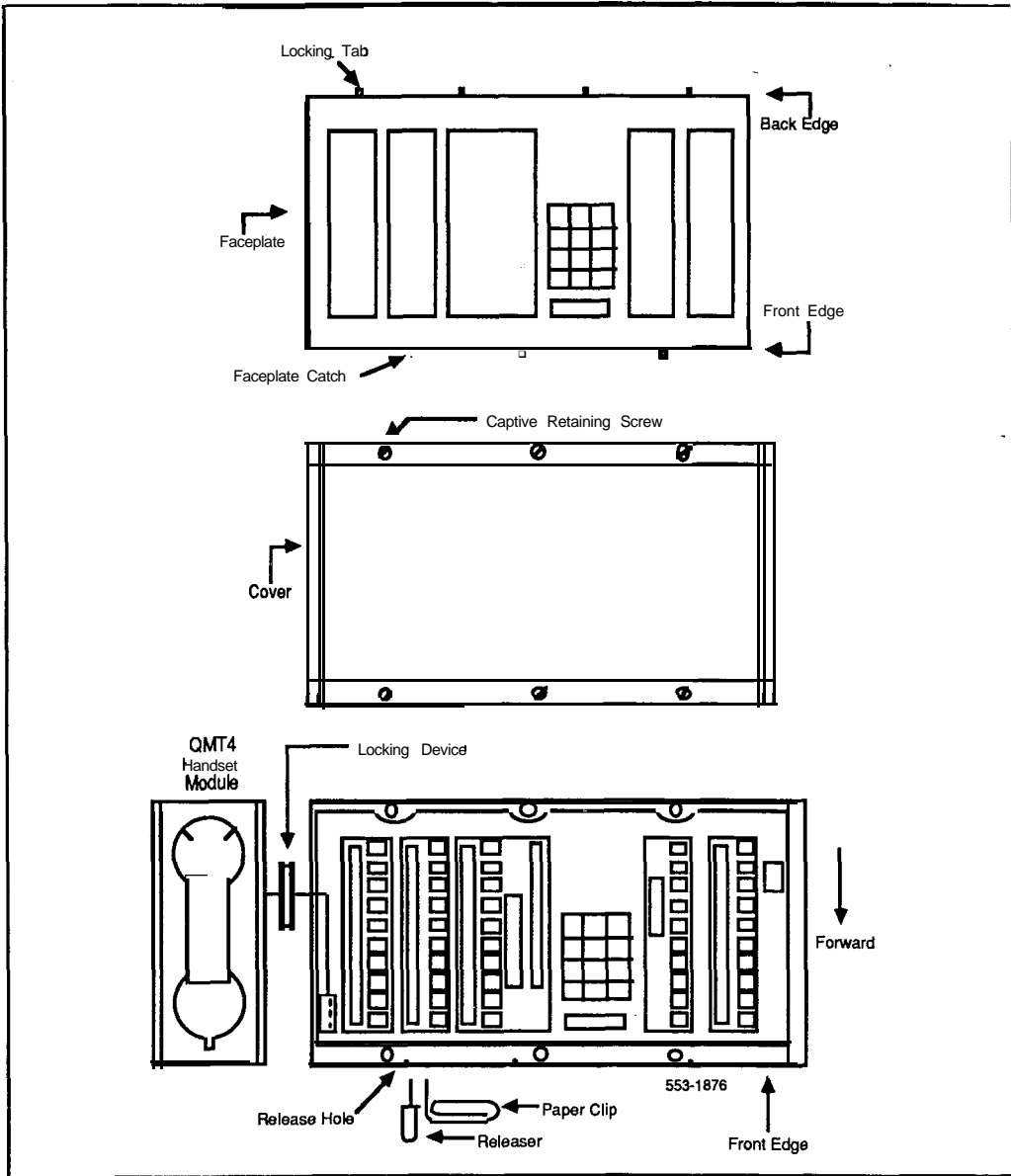

Procedure 5-15
Connecting QMT15 amplified handset module to QCW4E (and later) attendant console

- 1 Unplug handset from attendant console.
- 2 Remove and store filler plate from opening on left side of attendant console.
- 3 Insert plugs on right side of **QMT15** module, into jacks on left side of attendant console.
- 4 Ensure that the locking device on the right side of module is properly seated in the opening on the left side of the attendant console.
- 5 Tighten down the two locking screws on the locking device. The locking screws should protrude through the bottom of the locking device and press against the inside of the attendant console housing.
- 6 Plug handset into left side of handset module.

Procedure 5-16
Disconnecting QMT4C or QMT15 handset module from a QCW4E attendant console

- 1 Unplug handset from handset module.
- 2 If **QMT4C**, unplug module from left side of attendant console and-go to Step 6.
- 3 If **QMT15**, loosen the two locking screws on the locking device until screws no longer protrude through the bottom of the locking device.
- 4 Unplug the module from the side of the attendant console.
- 5 Install a filler plate in the opening on the left side of the attendant console.
- 6 Plug handset into left side of attendant console.

Procedure 5-17

Connecting amplified handset module QMT15 to a QCW2, QCW3, or QCW4D (or earlier) attendant console

- 1 Remove and store filler plate from opening on left side of attendant console.
- 2 Pass the connector assembly (housed in the handset module) through the locking device on the right side of module.
- 3 Insert plugs on right side of the **QMT15** module into jacks on left side of attendant console.
- 4 Ensure that the locking device on right side of module is properly seated in opening on left side of attendant console.
- 5 Tighten down the two locking screws on the locking device. The locking screws should protrude through the bottom of the locking device and press against the inside of the attendant console housing.
- 6 Extend the connector assembly from the **QMT15** module to jack in attendant console. Insert plug into jack.
 - If attendant console is equipped with **QMT1** and/or **QMT2** add-on key/lamp module(s), remove faceplate(s) and cover(s), extend the connector assembly through the openings between modules and connect the plug into the jack in the last module.
 - If the **QMT2** module is of C vintage or earlier, remove the screws securing the circuit board to the module housing and remove the circuit board. Insert the plug of the connector assembly into jack **J1**, replace the circuit board and secure with screws.
- 7 Ensure connector assembly wiring does not interfere with attendant console and module(s) (if equipped) covers.
- 8 Replace cover and faceplate on **QMT1** and/or **QMT2** modules if equipped.
- 9 Plug handset into handset module.

Procedure 5-I 8**Disconnecting QMT15 amplified handset module from a QCW2, QCW3, or QCW4D (or earlier) attendant console**

- 1 Unplug handset from handset module.
- 2 Remove faceplate and cover from QMT1 and/or QMT2 key/lamp module(s) if equipped.
- 3 Remove the connector assembly plug from the jack in the attendant console or last key/lamp module (if equipped).

If QMT2 module is vintage C or earlier, remove the screws securing the circuit board to the module housing and remove the circuit board. Remove the connector assembly plug from jack J1. Replace the circuit board and secure with screws.
- 4 Remove connector assembly from module(s) and/or attendant console.
- 5 Loosen the two locking screws on the locking device (between handset module and attendant console) until the screws no longer protrude through the bottom of the locking device.
- 6 Unplug the QMT15 handset module from the attendant console.
- 7 Install a filler plate in the opening on the left side of the attendant console.
- 8 Replace the cover and faceplate on the QMT1 and/or QMT2 module(s) if provided.
- 9 Plug handset into attendant console.

Table 5-7
QMT4 A/B Handset module wiring harness connections

Lead Color	PCB Designation
v-o	AAA
V-G	BBB
S-BR	CCC
S-W	DDD
V-S	HANDSET
V-BR	VSS

Table 5-8
Attendant console and key/lamp add-on module jack numbering

Equipment	Jack No.
QMT1 add-on module	J2
QMT2C add-on module	J1
QMT2D add-on module	J2
QCW2, 3 and 5 attendant consoles	J16
QCW4 attendant console	J2

Figure 5-16
QMT4A, B & C handset module

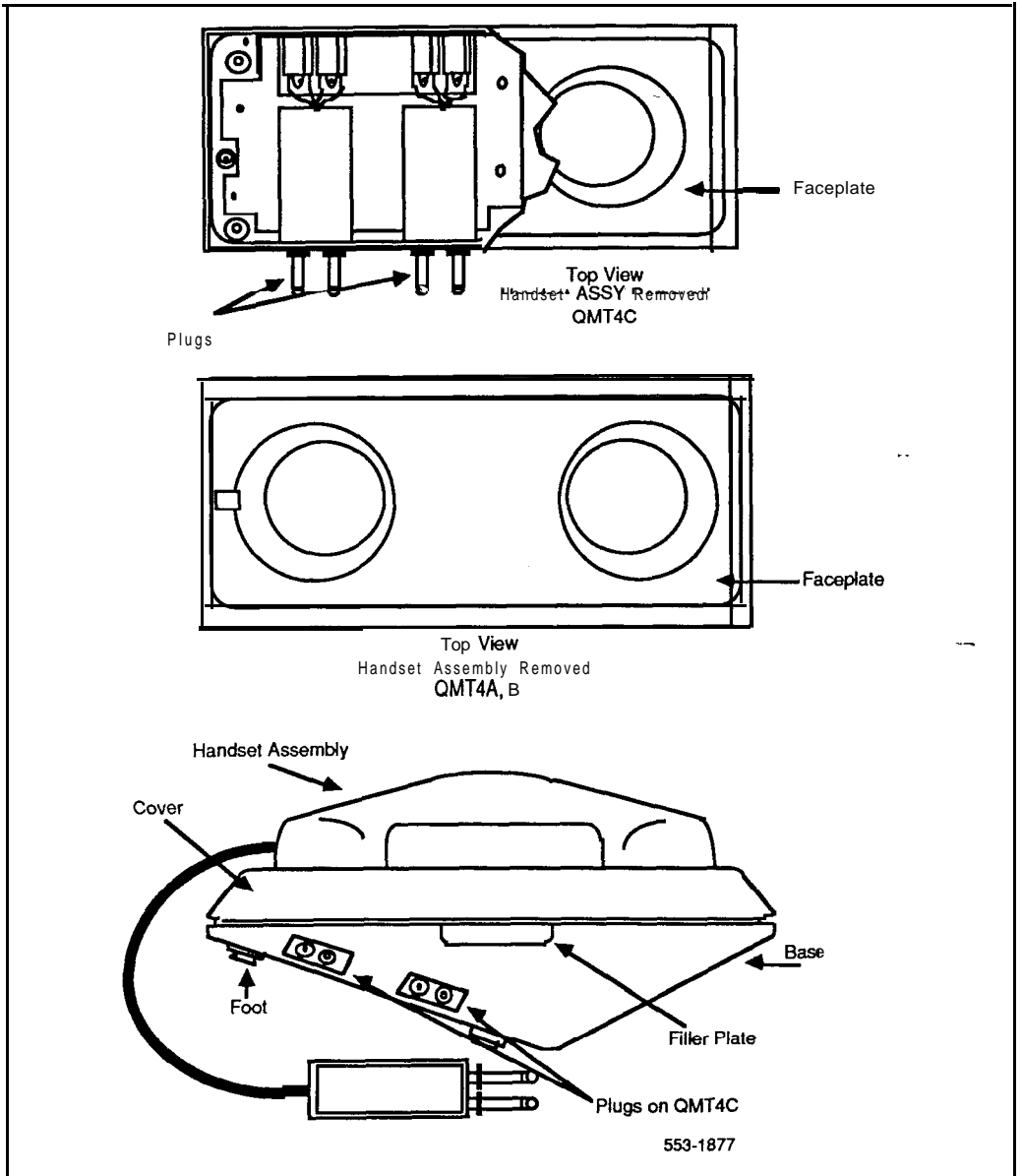

Figure 5-17
QMT15 amplified handset module

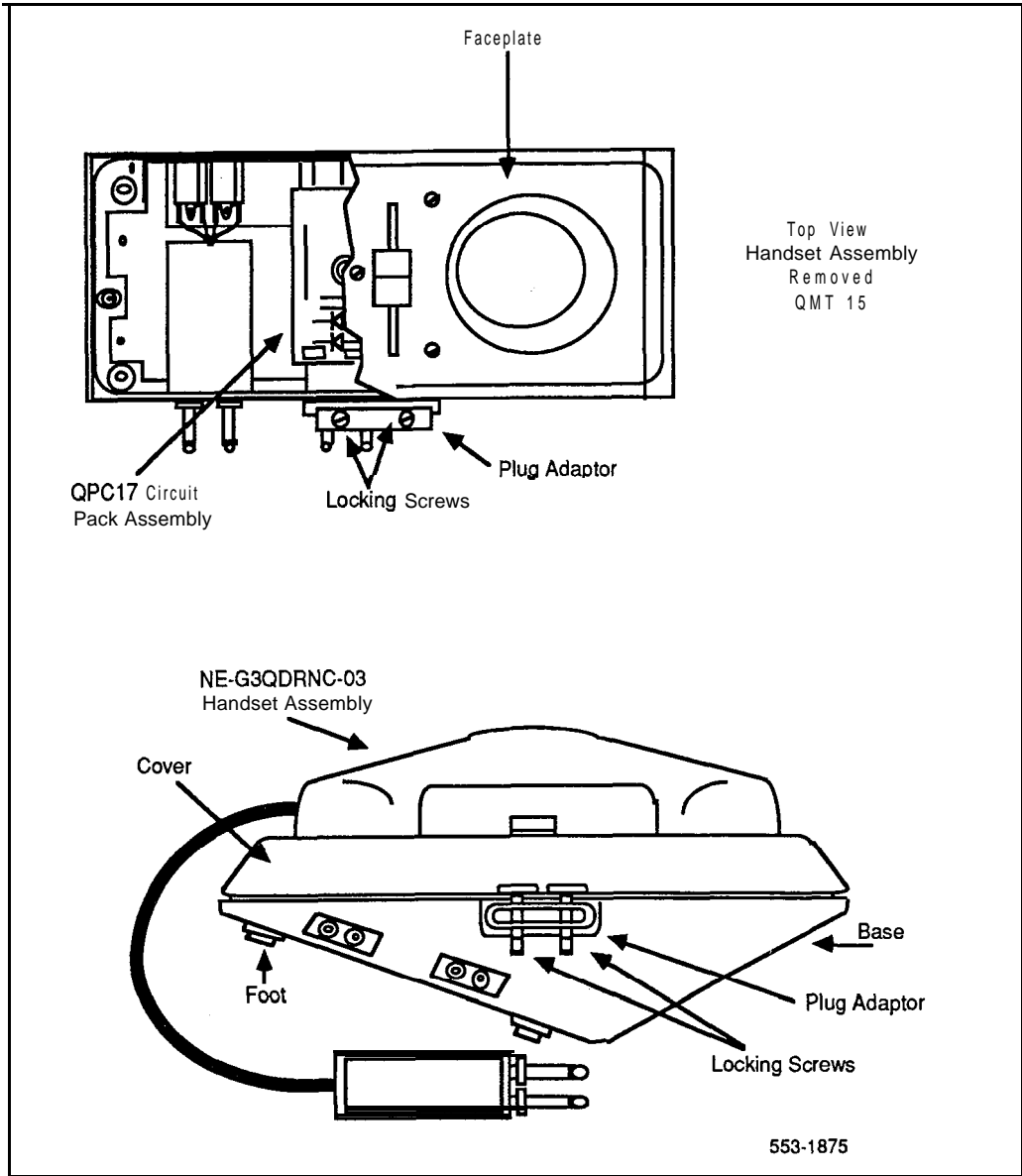
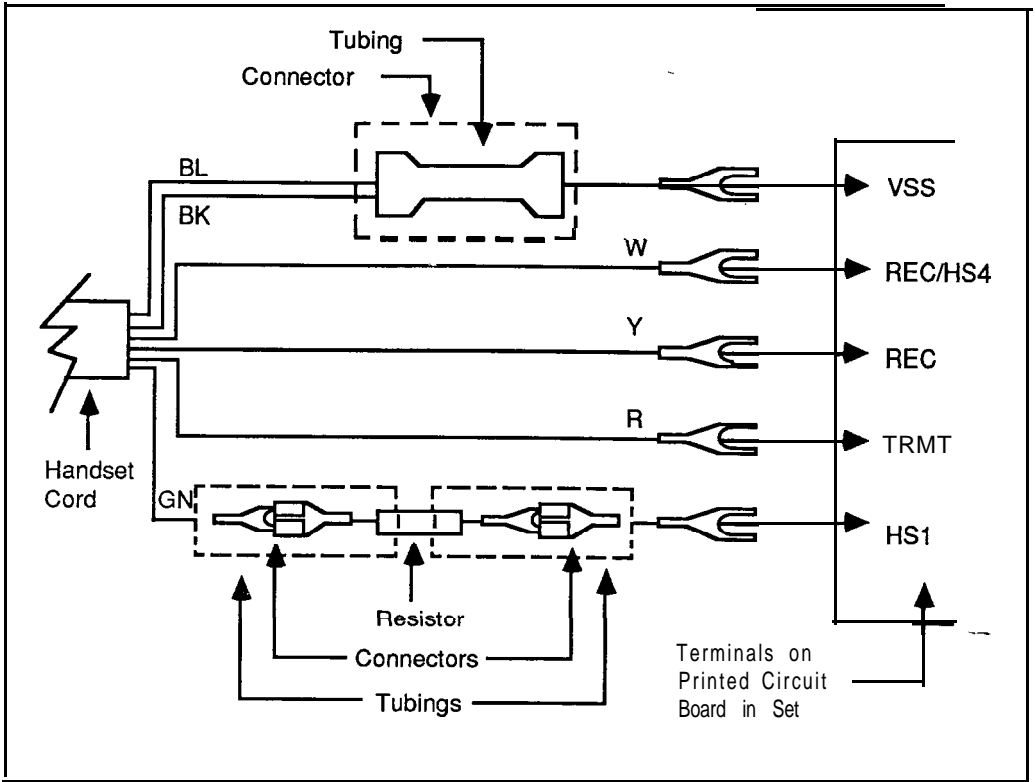

Figure 5-18
Current limiting kit connections



Amplified handset on SL-1 telephone sets

A PO630408 Current Limiting Kit is required to install **the** amplified handset on an SL- 1 telephone set.

Procedure 5-19

Connecting amplified handset

- 1 Disconnect existing handset cord from terminals TRMR, **REC/HS4**, REC and VSS on the Printed Circuit Board (**PCB**) in the set.
- 2 Remove handset and cord **from** set.
- 3 Connect the white lead from the cord of the amplified handset to terminal **REC/HS4** on the PCB in the set.
- 4 Connect the yellow lead from the cord of the amplified handset to terminal REC on the PCB in the set.
- 5 Connect the Red lead from the cord of the amplified handset to **terminal** TRMR on the PCB in the set.
- 6 Connect the blue and black leads **from** the cord of the amplified handset together **with** the bridging connector supplied with the Current Limiting Kit.
- 7 Connect extension lead (provided with the kit) to the bridging connector and insulate with tubing.
- 8 Connect extension lead to terminal VSS on the PCB in the set.
- 9 Connect Green lead from cord of amplified handset to connector on resistor (provided with the kit) and insulate with tubing.
- 10 Connect extension lead (provided with the kit) to the resistor and insulate with tubing.
- 11 Connect extension lead to connector HS 1 on the PCB in the set.
- 12 Secure handset cord to set with retaining clip on cord.

Procedure 5-20
Disconnecting amplified handset

- 1 Disconnect amplified handset cord from terminals VSS, **REC/HS4**, REC, **TRMR** and HS 1 on the Printed Circuit Board (**PCB**) in the set.
- 2 Remove handset and cord **from** set.
- 3 Connect one white lead from the cord of the regular G-type handset to terminal **REC/HS4** on the PCB in the set.
- 4 Connect the second white lead from the cord of the handset to terminal REC on the PCB in the set.
- 5 Connect the red lead from the cord of the handset to terminal **TRMR** on the PCB in the set.
- 6 Connect the Black lead **from** the cord of the handset to terminal VSS on the PCB in the set.
- 7 Secure handset cord to set with retaining clip on cord.

NE-G6QDC amplified handset on SL-1 telephone sets

A PO630408 Current Limiting Kit is required to install the amplified handset on an SL-1 telephone set.

Procedure 5-21 Installing amplified handset

- 1 Unpack and inspect current limiting kit and handset for damage.
- 2 Remove the faceplate and cover from the SL- 1 telephone set.
- 3 Connect the current limiting kit and the amplified handset.
- 4 Reattach cover and faceplate to the telephone.
- 5 Test the telephone by placing a call and adjusting the volume control on the handset.

Procedure 5-22 Removing amplified handset

- 1 Remove the faceplate and cover from the telephone set.
- 2 Disconnect the current limiting kit and handset and connect regular handset.
- 3 Reattach faceplate and cover to the telephone set.
- 4 Test the telephone set by placing a call.

QKK1, QKK3 Handsfree unit interface kit

The **QKK1** kit is used to modify an SL-1 telephone when a QSU-type Handsfree unit is to be added to the telephone set.

The **QKK3** kit is used to modify an SL-1 telephone when a QSU-type Handsfree unit is to be added to the telephone set and Automatic Answerback is to be provided. The addition of a **QKK3** kit reduces the number of key strip modules that can be added to an SL-1 telephone.

Refer to **QSU-Telephone sets, add-on modules, interface kits and M1 000 series telephones description** (553-2001-1 10) for add-on module limitations.

Both kits require a 24V ac power supply and can be used to extend the range of the telephone set as described in **QSU-Telephone sets, add-on modules, interface kits and M1000 series telephones description** (553-2001-110).

Procedures 5-23 and 5-24 explain how to connect and disconnect the **QKK1** interface kit, and Procedures 5-25 and 5-26 the **QKK3** interface kit.

Procedure 5-23 Connecting QKK1 kit

- 1 Disconnect the loudspeaker leads.
- 2 Remove the left-hand filler plate from the telephone set.
- 3 Mount the PCB of the kit in the base of the telephone set using the two attached mounting screws.
- 4 Connect the Y-BR lead of the PCB to (C15) terminal in the telephone set or to (REM PWR) terminal.
- 5 Insert connector P3 of the kit into jack J3 of the telephone set.
- 6 Insert the kit 15-pin plug assembly into the left-hand filler plate opening.
- 7 Connect the 25V ac auxiliary power supply to the telephone set.
- 8 Connect the loudspeaker leads.

Procedure 5-24
Disconnecting QKK1 kit

- 1 Disconnect the loudspeaker leads.
- 2 Remove the kit 15-pin plug assembly from the left hand filler plate opening in the telephone set.
- 3 Remove connector P3 of the kit from jack **J3** of the telephone set.
- 4 Disconnect the Y-BR lead of the kit PCB from the **(C15)** terminal in the telephone set or from (REM PWR) terminal.
- 5 Remove the two mounting screws which secure the kit PCB in the base of the telephone set. Remove the PCB.
- 6 Connect the loudspeaker leads.
- 7 Insert a filler plate into the filler plate opening.
- 8 Disconnect **25V** ac if not required.

Procedure 5-25
Connecting QKK3 kit

- 1 Disconnect the loudspeaker leads.
- 2 Remove the left-hand filler plate from the telephone set.
- 3 Mount the PCB of the kit in the base of the telephone set using the **two** attached mounting screws.
- 4 Insert connector P3 of the kit into jack J3 of the telephone set.
- 5 If the telephone set is equipped with a digit display or add-on **module**, move connector **P1** of digit display or add-on module from jack **J1** of the telephone to jack **J2** of the kit.
- 6 Insert connector **P1** of the kit into jack **J1** of the telephone set.
- 7 Insert the kit 15-pin plug assembly into the filler plate opening.
- 8 Connect a **25V** ac auxiliary power supply to the telephone **set**.
- 9 Connect the loudspeaker leads.

Procedure 5-26
Disconnecting QKK3 kit

- 1 Disconnect the loudspeaker leads.
- 2 Remove the kit **15-pair** plug assembly from the left hand filler plate opening in the telephone set.
- 3 Remove connector **P1** of the kit from jack **J1** of the telephone set.
- 4 If the telephone set is equipped with a digit display or add-on module, move connector **P1** of digit display or add-on module from jack **J2** of the kit to jack **J1** of the telephone set.
- 5 Remove **connector** P3 of the kit from jack J3 of the telephone set.
- 6 Remove the two mounting screws securing the kit PCB in the base of the telephone set.
- 7 Connect the loudspeaker leads.
- 8 **Insert** a filler plate into the **filler** plate opening.
- 9 Disconnect 25V ac supply if not required.

QSU1 Handsfree unit

This module is reissued to update information about modifying **Handsfree** units used with QKK3 interface kits.

Procedure **5-28** explains how to modify a QUS **1C2** Handsfree unit when used with a QKK3 interface kit.

Connection of a **Handsfree** unit to an SL-1 telephone requires a **QKK1 Handsfree** or QKK3 automatic Handsfree interface kit. Detailed information for the Handsfree units is contained in **513-6252-400** and 513-6262-200.

Only QUS **1C2** vintage Handsfree unit requires modification when used with a QKK3 interface kit. Other vintages of QUS **1C** Handsfree units do not require modification.

Procedure 5-27

Connecting the QSU1 Handsfree unit

- 1 Remove straps E 1 and E2 on the PCB of the telephone set if equipped; otherwise, move the connection from terminal **TRMR** to KR2 and from terminal **REC/HS4** to KR4.

For **QSU1C** and **QSU1D** sets, the dial pad must be removed to gain access to E2. For **QSU1F** telephone sets, disconnect one end of E1 and E2 by loosening the screw terminal and bending back the straps. Ensure that these straps do not contact any other terminal. Retighten the screws. These wiring modifications must be reversed if the QKK unit is removed.

- 2 Install interface kit as described in Procedure 5-23 (**QKK1**) or 5-25 (**QKK3**).
- 3 Plug the Handsfree unit into the interface kit **15-pin** connector.

Procedure 5-28**Modifying a QUS1C2 handsfree unit used with a QKK3 interface kit**

- 1 Loosen the retaining screws on the bottom of the Handsfree unit, and remove the cover.
- 2 Move the Y-S lead from terminal B .*(2C for QUS 1C4/5) to terminal VBB with the R-G lead.
- 3 Move the S-Y lead from terminal R .*(M2 for QUS1C4/5) to terminal ON with the O-V lead.
- 4 Move the G lead from terminal M2 .*(2O for QUS 1C4/5) to terminal OFF with the S-V lead.
- 5 **Replace** the cover on the QUS 1C unit and tighten the retaining screws.

It is not necessary to return these leads to their original terminals when using a QKK2 interface kit.

Procedure 5-29**Disconnecting the QSU1 Handsfree unit**

- 1 Reconnect straps E 1 and E2 on the PCB of the telephone set, if equipped. Otherwise, move the connection from terminal KR2 to TRMR and from terminal KR4 to REC/HS4.

For QSU1C and QSU1D telephone sets the dial pad must be removed to gain access to E2. For QSU1F sets, bend the E1 and E2 straps back to the terminals and reconnect. Tighten the screws.

- 2 Unplug the Handsfree unit from the interface kit **15-pin** connector.
- 3 Remove interface kit if not required for remote powering.

Handsfree unit on a QSU71 telephone set

QSU71 telephone sets are shipped with Handsfree enabled. If Handsfree has been disabled, follow the steps in Procedure 5-30.

Procedure 5-30 Enabling Handsfree

- 1 Remove the handset and place it beside the telephone set.
- 2 Place the set face down on a flat surface and leave in this position until after the base and TELADAPT cords are reattached.
- 3 Disconnect the **TELADAPT** cords from the base of the telephone set.
- 4 Remove **the** four retaining screws from the base of the QSU71 telephone set and carefully lift off the base.
- 5 Locate the three pin header connector J6, on the upper housing circuit board. If Handsfree is disabled, header connector removeable plug **will** not be inserted into the connector **J6** socket pin 1 (pin 1 of **the** three pin header connector is indicated by a white dot on the circuit board).
- 6 Unplug the removeable header connector by gently pulling on the solid head of the removeable plug.
- 7 Place the removeable plug into the connector, ensuring pins 1 and 2 are connected to the pins 1 and 2 of the connector socket. --
- 8 If Automatic Answerback is required, go to Procedure 5-32, otherwise reattach **the** base of the set to the upper housing cover using the four screws removed in Step 4.
- 9 Reconnect the **TELADAPT** cords to the base of the telephone set.
- 10 Turn the telephone set face up and place the handset on hook.

Procedure 5-31
Disabling Handsfree

- 1 Remove the handset and place it beside the telephone set.
- 2 Place the set face down on a flat **surface** and leave **in** this position until after the base and TELADAPT cords are reattached.
- 3 Disconnect the TELADAPT cords from the base of the telephone set.
- 4 Remove the four retaining screws from the base of the QSU71 telephone set and carefully lift off the base.
- 5 Locate the three pin header connector **J6**, on the upper housing circuit board.

If Handsfree is enabled, header connector removeable plug pins 1 and 2 will be inserted into the connector **J6** socket pins 1 and 2 (pin 1 of the three pin header connector is indicated by a white dot on the circuit board).

- 6 Unplug the header connector by gently pulling on the solid head of the removeable plug.
- 7 Place the removeable plug into the connector, ensuring pin 1 is not connected to the connector socket.
- 8 Reattach the base of the set to the upper housing cover using the **four** screws removed in Step 4.
- 9 Reconnect the TELADAPT. cords to the base of the telephone set.
- 10 Turn the set face up and place the handset on hook.

QKK8 Automatic Answerback

The **QKK8** Automatic Answerback kit **can only** be installed in MI 109 Compact (QSU71) Telephones.

Procedure 5-32 **Installing QKK8 unit**

- 1 Remove the handset and place it beside the telephone set.
- 2 Place the set face down on a flat surface and leave the telephone set in this position until after the base and TELADAPT cords **are** reattached.
- 3 Disconnect the TELADAPT cords from the base of the telephone set.
- 4 Remove the four retaining screws from the base of the QSU71 telephone set, carefully lift off the base and place it beside the set.
- 5 Place the **QKK8** unit on top of the mounting holes located on the top right corner of the base (viewed with the base flat, handset to the left).
- 6 Secure the **QKK8** unit to the base of the telephone set with the screws provided.
- 7 Connect the **QKK8** connecting plug to the J3 connector (located on the upper housing circuit board).
- 8 Reattach the base of the telephone set to the upper housing using the screws removed in Step 5.
- 9 Turn the telephone set face up and place the handset on hook.

Procedure 5-33
Removing QKK8 unit

- 1 Remove the handset and place it beside the telephone set.
- 2 Place the telephone set face down on a flat surface and leave it in this position until after the base and **TELADAPT** cords are reattached.
- 3 Disconnect the **TELADAPT** cords from the base of the telephone set.
- 4 Remove the four retaining screws from the base of the QSU7 1 telephone set, carefully lift off the base and place it beside the telephone set.
- 5 Disconnect the QKK8 connecting plug from the J3 connector (located on the upper housing circuit board).
- 6 Remove the screws attaching the **QKK8** unit to the base of the telephone set and remove the **QKK8** unit from the base.
- 7 Reattach the base of the telephone set to the upper housing **using the** screws removed in Step 5.
- 8 Turn the telephone set face up and place the handset on hook.

Table 5-9

SL-1 Telephone connections

Mounting Cord		Connecting Block Designations			Inside Wire Colors		
Lead Name	Color	N E-47QA or QBB1B	NE-283 73 5001 Adapter	NE-625F TELADAPT	Z Station Wire	16/25 Pair	Connect to Equipment TN
Audio T	G	G	1T	T1 (G)	G	W-BL	1 st pair Tip
Audio R	R	R	1R	R1 (R)	R	BL-W	1 st pair Ring
SIGT	BK	BK	X1	AUX (BK)	BK	w-o	2nd pair Tip
SIGR	Y	Y	x2	GRD (Y)	Y	o-w	2nd pair Ring
AC1	BL	5	R	T2 (BL)		w-SL	Aux Power Note 1
AC1	W	6	B	R2 (W)		SL-w	

Note 1: Connect to auxiliary power when the telephone is equipped with add-on modules. Telephones with a Digit Display always require an auxiliary 25V supply. Use one of the following for auxiliary power:

25V ac and 15V ac transformers located within 25 ft. of the telephone set.

QUT1 or QUAA1 centralized power supply. To prevent noise and crosstalk, each telephone set should have its own transformer, or fuse (if using centralized power).

Note 2: See the cross-connections to SL-1 System equipment.

QKM11 adapter kit

The **QKM11A** adapter kit is used to upgrade existing **QSU6B/QSU7C** SL-1 telephone sets to vintage **QSU6C/QSU7D** respectively. This kit replaces covers, relocating the agent jacks from the left-hand side to the front of the telephone set. The kit includes a moulded plastic cover, cable assembly, hole plug buttons and required screw and washers.

Procedure 5-34

QKM11 adapter kit installation

- 1 Remove the faceplate and cover from the telephone set (vintage **QSU6B** or **QSU7C**).
- 2 Detach the loudspeaker and foam insert
- 3 Unscrew and remove the lower jacks from the left-hand side of the telephone set.
- 4 Remove the connector cable between the **QPC266** sub-board and **QPC 100** main board.
- 5 Remove the **QPC266** sub-board from the base of the telephone set and attach it to the underside of the new cover with supplied screws.
- 6 Using the cable connector supplied with the adapter kit, reconnect the **QPC266** sub-board to the **QPC100** main board. --
- 7 Connect the jacks (removed in Step 3) into the front of the new telephone set cover.
- 8 Connect the foam insert and loud speaker (removed in Step 2) to the new set cover.
- 9 Use hole plug buttons supplied with the adapter kit to fill the holes in the left-hand side of the telephone set (where the agent jacks were).
- 10 Attach the new cover and faceplate to the telephone set.
- 11 Test the telephone set: Refer to **SL-1 XI 1 input/output guide** (553-3001-400).

QKM13 light probe kit

The light probe enables sight impaired attendants or SL- 1 telephone set users to use existing QCW-type attendant consoles or QSU-type SL-1 telephone sets.

The probe has a light sensor on one end and a small button on the other end. To operate the probe, the user presses the button and then scans the LED strips on the attendant console or SL-1 telephone set. A tone is heard in the headset or handset when the light sensor is placed over an LED that is on.

Some devices inside the light probe kit can be damaged by static electricity. Before working on the light probe kit, touch ground or faceplate contact of set or attendant console to discharge electricity from body.

The **QKM13A** kit cannot be added to a attendant console equipped with the QMT3 Busy Lamp Module.

A **PO643059** connector kit is required to install the **QKM13** in an SL-1 telephone set.

Procedure 5-35**Installing the QKM13 Light Probe kit in attendant console**

- 1 Remove faceplate and cover from attendant console and add-on module(s) if equipped.
- 2 Remove left hand filler plate from attendant console.
- 3 This step applies to all attendant consoles except **QCW4E** and later vintages.
 - Connect the S-G lead from the light probe PCB to terminal BBB located on the left front corner of the PCB in the attendant console base assembly.
 - Connect the S-Y lead from the light probe PCB to terminal VSS located on the left front corner of the PCB in the attendant console base assembly.
 - Plug the connector on the BL-R lead into connector J16 (**J2** on QCW4 attendant consoles) located at right rear corner of PCB in attendant console base assembly, or extension jack in **last** add-on module, if equipped.
- 4 This step applies only to **QCW4E** (and later vintage) attendant consoles. --
 - Turn attendant console upside down.
 - Remove slide at bottom of attendant console to obtain access to line cord connector.
 - Remove screw securing connectors and separate connectors.

-continued-

- Turn attendant console rightside up.
 - Remove three screws along the top edge and three screws along the bottom edge of the main Printed Circuit Board (PCB) of the attendant console.
 - Lift the PCB assembly from the attendant console.
 - Using a spare lead from the light probe kit, extend the S-G lead to terminal **JK5-S** located near the line cord connector on the lower PCB.
 - Using a spare lead from the light probe kit, extend the S-Y lead to terminal COMM located near the line cord connector on the lower PCB.
 - Reinstall the main PCB in the attendant console.
 - Plug the connector on the BL-R lead into connector J2 located at right rear corner of PCB in attendant console base assembly, or extension jack in last add-on module, if equipped.
 - Turn attendant console upside down, reconnect line cord connector and secure to bottom of attendant console with retaining screw.
 - Reinstall slide on line cord connector opening and turn attendant console upside right.
- 5 Insert light probe PCB into filler plate opening on left side of attendant console.
- 6 Replace cover and faceplate on attendant console and module(s) if equipped.
- 7 Plug light probe cable into jack on the PCB in filler plate opening on left side of attendant console.
- 8 Plug the headset/handset into either jack on attendant console and test light probe. A tone should be heard only when the probe is over a lit LED. The headset/handset should be plugged into the jack (on the attendant console) that provides the loudest tone.

Procedure 5-36**Removing the QKM13 Light Probe kit from attendant console**

- 1 Unplug light probe cable from **PCB** jack in filler plate opening on left side of attendant console.
- 2 Remove faceplate and cover from attendant console and add-on module(s), if equipped.
- 3 This step applies to all attendant consoles except **QCW4E** and later vintages.
 - Disconnect the connector on the BL-R lead from connector **J16** (J2 on **QCW4** attendant consoles) located at right rear corner of **PCB** in attendant console base assembly, or extension jack in last add-on module, if equipped.
 - Disconnect the S-G lead from the light probe **PCB** to terminal **BBB** located on the left front corner of the **PCB** in the attendant console base assembly.
 - Disconnect the S-Y lead from the light probe **PCB** to terminal **VSS** located on the left front corner of the **PCB** in the attendant console base assembly.

-continued-

--

- 4 This step applies only to **QCW4E** (and later vintage) attendant consoles.
 - Turn attendant console upside down.
 - Remove slide at bottom of attendant console to obtain access to line cord connector.
 - Remove screw securing connectors and separate connectors.
 - Turn attendant console upside right.
 - Disconnect the connector on the BL-R lead from connector J2 located at right rear corner of PCB in attendant console base assembly, or extension jack in last add-on module, if equipped.
 - Remove three screws along the top edge and three screws along the bottom edge of the main Printed Circuit Board (**PCB**) of the attendant console.
 - Lift the PCB assembly from the attendant console.
 - Disconnect the S-G lead from the light probe kit to terminal **JK5-S** located near the line cord connector on the lower PCB .
 - Disconnect the S-Y lead from the light probe kit to terminal **COMM** located near the line cord connector on the lower PCB.
 - Reinstall the main PCB in the attendant console.
 - Turn attendant console upside down, reconnect line cord connector and secure to bottom of attendant console with retaining screw.
 - Reinstall slide on line cord connector opening and turn attendant console upside right.
- 5 Remove light probe PCB from filler plate opening on left side of attendant console.
- 6 Insert filler plate into opening on left side of attendant console.
- 7 Replace cover and faceplate on attendant console and module(s), if equipped.
- 8 Pack QKM13 light probe kit and store or return to supplier.

Figure 5-1 9
Light Probe PCB connections to attendant console and SL-1 Telephone

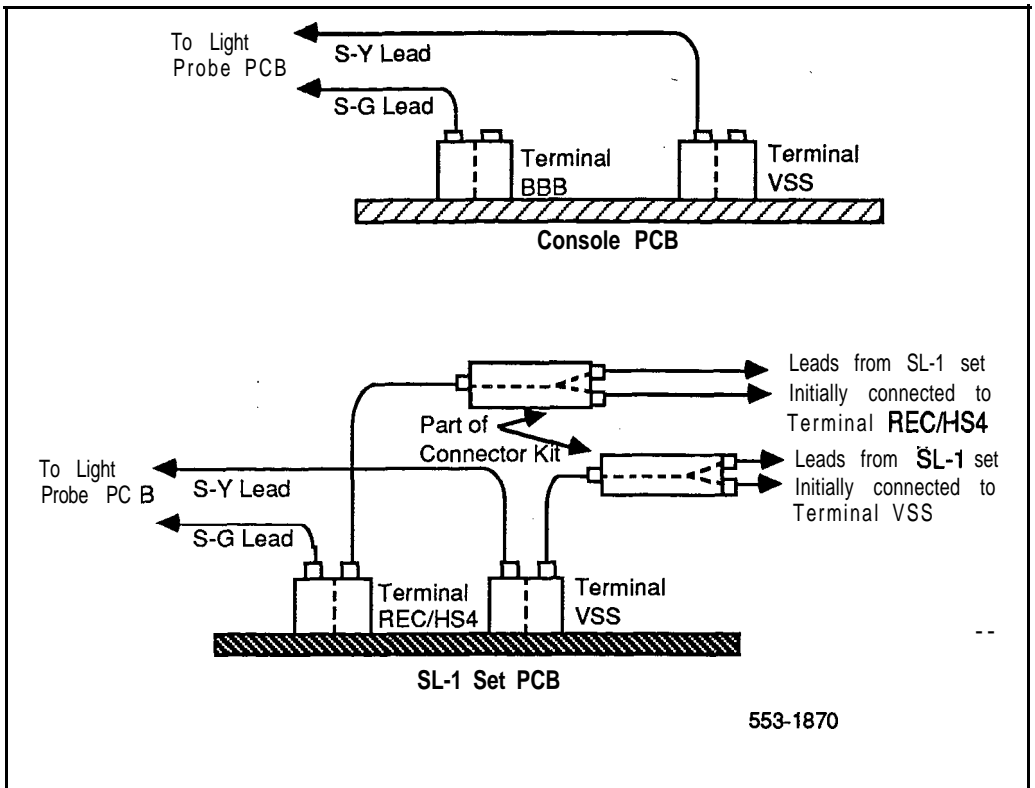

Procedure 5-37

Installing the QKM13 Light Probe kit in an SL-1 telephone

- 1 Remove the faceplate and cover from the set and add-on module(s) if **equipped**.
- 2 Remove the filler plate from left side of telephone set.
- 3 Insert the light probe PCB into the filler plate opening on the left side of telephone set.
- 4 Remove the two wires on terminal **REC/HS4** on the set PCB and connect the wires to connector kit.
- 5 connect the wire from the connector kit to terminal **REC/HS4** on telephone set PCB.
- 6 Connect the (S-G) lead from the light probe PCB to terminal **REC/HS4** on telephone set PCB.
- 7 Remove the two wires from terminal **VSS** on set PCB and connect the wires to connector kit.
- 8 Connect the wire **from** the connector kit to terminal **VSS** on set PCB.
- 9 Connect the (S-Y) lead from the light probe PCB to terminal **VSS** on telephone set PCB.
- 10 Plug the light probe PCB female connector (BL-R lead) into jack **J1** in the set or into the extension jack in the last add-on module.
- 11 Replace cover and faceplate on telephone set and add-on module(s), if equipped.
- 12 Plug light probe cable into jack on PCB in filler plate opening on left side of telephone set and test. A tone should be heard only when the probe is over a lit LED.

Procedure 5-38
Removing the QKM13 Light Probe kit from an SL-1 telephone

- 1 Unplug light probe cable from PCB jack in filler opening on left side of telephone set.
- 2 Remove faceplate and cover from telephone set and add-on module(s) if equipped.
- 3 Unplug the light probe PCB female connector (BL-R lead) from jack **J1** in the telephone set or from the extension jack in the last add-on module.
- 4 Disconnect light probe PCB leads (S-Y) and (S-G) from terminals **VSS** and **REC/HS4** on telephone set PCB.
- 5 Disconnect the wire going to connector kit from terminal **VSS** on telephone set PCB.
- 6 Disconnect the two wires connected to the opposite end of the connector kit and connect these wires to terminal **VSS** on telephone **set** PCB.
- 7 Disconnect the wire going to connector kit from terminal **REC/HS4** on telephone set PCB.
- 8 Disconnect the two wires connected to the opposite end of the connector kit and connect these wires to terminal **REC/HS4** on -- telephone set PCB.
- 9 Remove light probe PCB from filler plate opening and the connector kits from the telephone set.
- 10 Insert filler plate into opening on left side of telephone set.
- 11 Replace cover and faceplate on telephone set and add-on module(s), if equipped.
- 12 Test set to ensure proper operation.
- 13 Pack QKM13 light probe kit and store return to supplier.

QUT1 power unit and transformer

The **QUT1** power unit is designed to supply power for add-on units of up to eleven SL- 1 telephones or attendant consoles from a centralized location.

When AC transformers are used to provide auxiliary power to attendant consoles **or** sets a separate **25V** and/or **15V** ac transformer is required for each attendant console or telephone set.

Procedure 5-39

Installing the QUT1 power unit

- 1 Unpack, inspect **QUT1** unit. If damaged, repack and return to supplier.
- 2 Determine, from the work order where to install the power units. (equipment room or terminal closet.)
- 3 Place the power unit on a flat surface face up.
- 4 Completely loosen the two screws securing the cover of the unit and remove the cover.
- 5 Remove the two screws (diagonally opposite comers) securing the metal backboard to the power unit.
- 6 Mount the backboard on wall within 6 ft (1830 mm) of a **117V** ac electrical outlet.
- 7 Place the power unit on the backboard so that the holes in the back of the power unit engage the hooks on the backboard.
- 8 Secure the power unit to the backboard with the two machine screws previously removed.
- 9 Loosen the two screws securing the connector clamp located on the front (lower left) of the power unit and slide **the** clamp downwards.
- 10 Select an NE-A25B (or equivalent) connector cable of suitable length.
- 11 Insert the connector on the cable, into the connector jack on the power unit. Run the cable slightly to the right and then down through the bottom entry hole of the power unit.

—continued—

Figure 5-20
QUT1 power unit faceplate

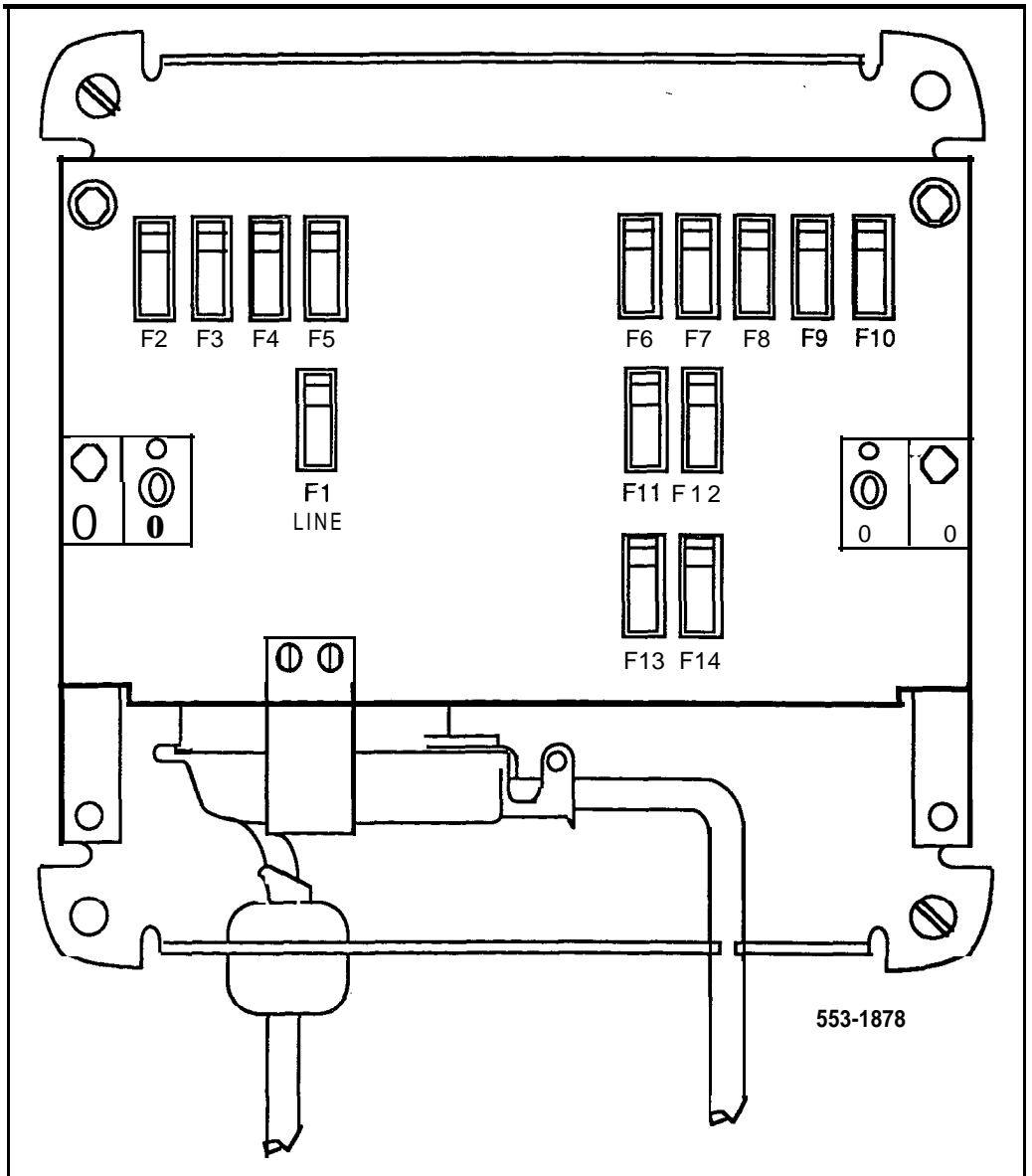

- 12 Mount a 25-pair NE-66 (or equivalent) type connecting block in the yellow of wall mounted cross-connect terminal or on the horizontal side bottom row of distributing frame. Designate connecting block.
- 13 Terminate the end of the cable on the connecting block, following the sequence provided in Figure 5-21.
- 14 Insert appropriate fuses (if not provided) in fuse holders, on the power unit, as required.
- 15 Place the cover on the power unit. Secure the cover with the two retaining screws provided with the cover.
- 16 Cross-connect to attendant console or telephone set as required.

Figure 5-21
QUT1 power unit connections

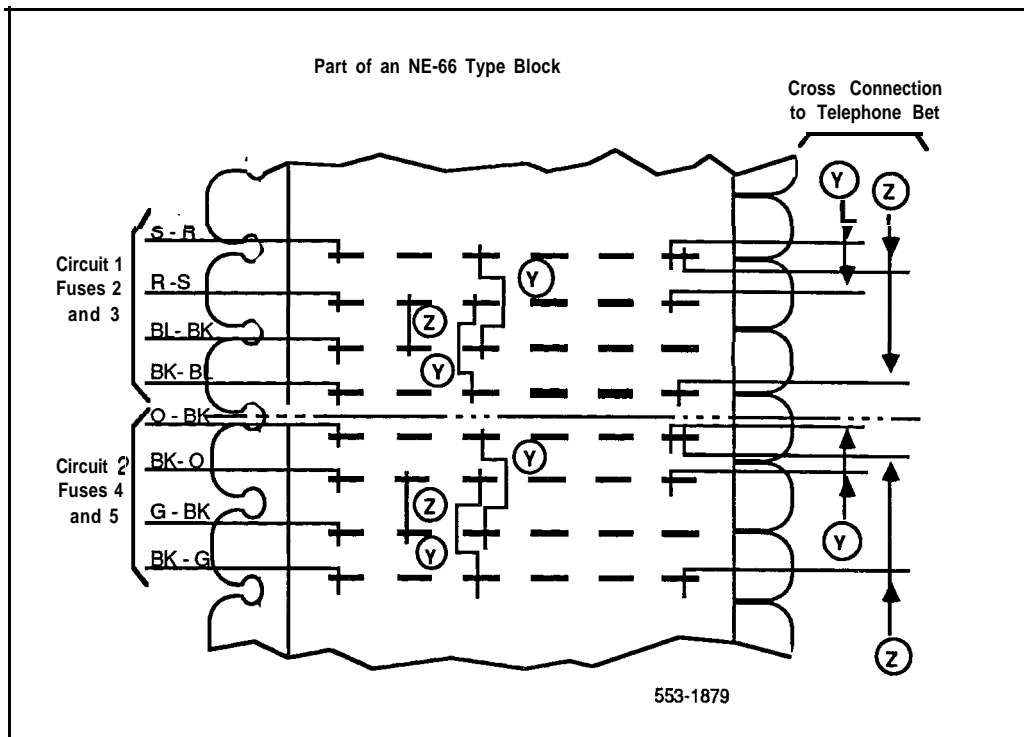

Procedure 5-40 .
Removing the QUT1 power unit

- 1 Completely loosen the two screws securing the cover of the power unit and remove the cover.
- 2 Remove the ac plug from the 117V ac-electrical outlet.
- 3 Loosen the two screws securing the connector clamp, located on the front (lower left) of the power unit, and slide the clamp downwards.
- 4 Disconnect the connector on the cable from the connector jack on the power unit.
- 5 Remove the two machine screws securing the power unit to the backboard.
- 6 Unhook the power unit from the backboard. Place unit on flat surface with face up.
- 7 Remove the screws securing the metal backboard to the wall. **Remove** the backboard.
- 8 Secure the metal backboard to the removed power unit with the two machine screws previously removed.
- 9 Replace cover on power unit and secure with mounting screws.
- 10 Remove the 25-pair connector cable running to the cross-connect -- terminal, if no longer required.
- 11 Remove power cross-connections from **66-type** connecting block to attendant console or telephone set.

Procedure 5-41
Installing the transformer

- 1 Plug 15V or 25V ac transformer into **115V** ac power outlet located within 25 ft (7620 mm) of the telephone set or attendant console.
- 2 Connect and run 3-wire 24 AWG Z station wire from the transformer to the attendant console or telephone set connecting block.
- 3 Connect the attendant console or telephone set.

Procedure 5-42
Removing the transformer

- 1 Unplug 15V or 25V ac transformer **from 115V** ac power outlet.
- 2 Disconnect and remove Z station wire from transformer and attendant console or telephone set connecting block.

Table 5-10
QUT1 Power Unit fusing

Fuse	Use	Type	Rating (A)
F1	117V AC line	QFF1A	2-1/3
F6-F14	25V	QFF1G	1/2
F3-F5*	12.5V	QFF1G	1/2
F3-F5**	12.5V	QFF1G	1/2

Note: . Z option : F3-F3, F5-F5 in series, 25 V
 ** Y option : F3-F3, F5-F5 in parallel, 12.5 V

Table 5-1 1
QUT1 connections

NE-66 Pair	Color	QUT1	Voltage
1	BL-W W-BL	FUSE6	25V
2	o-w w-o	FUSE 7	25V
3	G-W W-G	FUSE 8	25V
4	BR-W W-BR	FUSE 9	25V
5	s-w w-s	FUSE 10	25V
6	BL-R R-BL	FUSE 11	25V
7	O-R R-O	FUSE 12	25V
8	G-R R-G	FUSE 13	25V
9	BR-R R-BR	FUSE 14	25v
10	S-R R-S	FUSE 2	12.5V
11	BL-BK BK-BL	FUSE 3	12.5V

—continued—

Table 5-11
QUT1 connections (continued)

NE-66 Pair	Color	QUT1	Voltage
12	O-BK BK-O	FUSE 4	12.5V
13	G-BK BK-G	FUSE 5	12.5V
14	BR-BK BK-BR		
15	S-BK BK-S		
16	BL-Y Y-BL		
17	O-Y Y-O	—	
18	G-Y Y-G	—	
19	BR-Y Y-BR	—	
20	S-Y Y-S	—	
21	BL-V V-BL	—	

—continued—

Table 5-I 1
QUT1 connections (continued)

NE-66 Pair	Color	QUT1	Voltage
22	O-V V-O	—	—
23	G-V V-G		—
24	BR-V V-BR		
25	S-V V-S	—	—

Table 5-1 2
Allowable distance from QUT1 to telephone set

Tel ephoneequipped with:	22 AWG ft. (m)	24 AWG ft. (m)	26 AWG ft. (m)
10 KL module *	11000 (3390)	7150 (2200)	4550 (1400)
20 KL module . *	5550 (1710)	3500 (1076)	2200 (677)
10 &pl. 20 KL module	3650 (1120)	2300 (708)	1450 (446)
20 &pl. 20 KL module	2650 (815)	1700 (524)	1050 (324)
20 &pl. 20 +KL module	2100 (647)	1300 (400)	850 (262)
HFU + 10 KL module ***	905 (278)	575 (177)	365 (112)
HFU + 20 KL module	755 (232)	480 (148)	320 (98)
HFU + 20 + 10 KL module	650 (200)	410 (126)	260 (80)
HFU + 20 + 20 &pl. 10 KL module	500 (154)	315 (97)	200 (62)

Note: Cable pairs may be doubled to double the allowable distance to the telephone set.

- 10 KL = 10-button key/lamp
- * 20 KL = 20-button key/lamp
- *** HFU = handsfree unit

Table 5-1 3
Allowable distance from QUT1 to Lamp Field Array module

	22 AWG ft(m)	24 AWG ft(m)	26 AWG ft(m)
	130 (40)	80 (24.6)	50 (15.4)

Table **5-1 4**
Allowable distance from QUT1 to attendant console

Equipment	22 AWG ft (m)	24 AWG ft (m)	26 AWG ft (m)
Attendant console	1850 (568)	1200 (369)	750 (231)
Attendant console + LA module	1600 (492)	1000 (308)	650 (200)
Attendant console + 10 KL module	1600 (492)	1000 (308)	650 (200)
Attendant console + 10 KL + LA module	1400 (431)	900 (277)	550 (169)
Attendant console + 20 KL module	1400 (431)	900 (277)	550 (169)
Attendant console + 20 KL + LA module	1250 (385)	800 (246)	500 (154)

--

Note: The distances given in this figure are for the 24V supply. If 15V for the lamp array module is supplied from the same cower unit, the distance is limited to that given in Figure 5-13.

M2000/M2317/M3000 Data Options

If an existing digital telephone set was not originally equipped with the Data Option, or if the existing data option has become defective, that option can be added or replaced. The following procedure explains how to install the Data Option for the **M2000** Digital Telephone sets.

CAUTION

CMOS devices inside the telephone can be damaged by electrostatic charge. Before opening any **M2000** telephone, hands and tools must be discharged by touching any grounded metal surface or conductor.

Procedure 5-43

Installing the **M2000/M2317/M3000** Data Option

- 1 Remove handset, and place the telephone upside down on a level workplace (a desktop, for example).
- 2 Disconnect all cords from the telephone set.
- 3 Loosen and remove **five** screws in the base of the telephone set, lifting the base upward.
- 4 If the telephone set is not equipped with the Data Option, proceed with step 5.

If the telephone set is equipped with a defective Data Option, carefully disconnect the ribbon cable connector from the header connector in the digital printed circuit board. Loosen and remove the two self tapping screws that fasten the data option to the telephone set base and remove the defective Data Option. Proceed with step 6.

- 5 Remove the breakout section in rear of the telephone set base by tapping it with the handle of a small screwdriver.
- 6 Place the black, plastic connector shroud over the RS-232-C interface connector.

Note: It is not possible to install the shroud after the board has been inserted in the telephone set base.

—continued—

- 7 Tip the circuit board up and insert, connector end first, under tabs in the base. Position over the molded locating pins, then lower the board completely into position in the telephone set base. Use the two Phillips self tapping screws supplied **with** the board and install them through the mounting holes. Tighten the screws.
- 8 Plug the ribbon cable connector into the header connector, located on the existing circuit board of the telephone set (mounted on the faceplate assembly) There is only one such connector on the telephone set's circuit board. Make sure the connector is snug.
- 9 In **M2112** Digital Telephones equipped with Handsfree, make certain that the rubber gasket covering the microphone cavity is firmly in place before closing the case.
- 10 Reassemble the telephone set by placing the base section on the faceplate section. Reinstall the five (5) screws.
- 11 Tighten the screws, reconnect all cords, and place the telephone set back in its former position.

Procedure 5-44
Installing the M2000/M2317 data terminal

- 1 Connect the RS-232-C interface connector from the data terminal to the matching header connector in the back of the telephone set.
- 2 Insert the two captive screws in the connector body into the threaded holes in the header connector. Secure tightly to prevent accidental disconnection during data terminal operation.
- 3 Plug keyed power supply connector securely into the right of the RS-232-C connector.
- 4 Plug the wall transformer into the nearest ac outlet. The data terminal is now operational.



Figure 5-22
M2000/M2317 data terminal and Data Option power supply connection

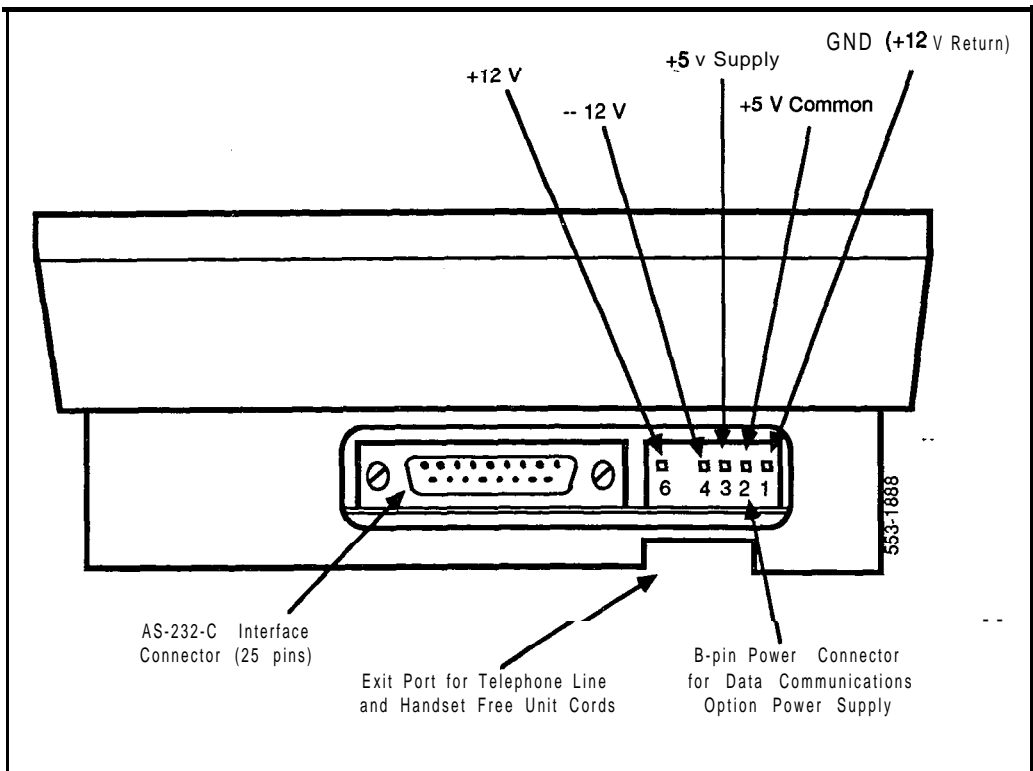

Note 1: If an ADM3, ADM5, or ADM11 terminal is used in conjunction with the RS-232-C connector in the Asynchronous Data Option, pin 22 in the RS-232-C cable must be disconnected. The quoted ADM terminals will go into test mode if this pin is not disconnected.

Note 2: A special 9 pin connector is required to connect the Apple Macintosh to the RS-232-C connector in the M2000 Asynchronous Data Option. The connections are shown in Table 5-15.

Table 5-15
Connections for Apple Macintosh to M2000/M2317 Data Option

9 Pin Connector (from terminal)		25 Pin (M-232-C) Connector (at Data option port).	
Pin 3	to	Pin 7	
Pin 5	to	Pin 2	
Pin 9	to	Pin 3	

Note: Strap pins 4 and 5, and pins 6, 8, and 20 together.

Table 5-18
RS-232-C signals and associated pin numbers for M2317 telephone sets

EIA	Circuit designation		Pin number	Signal source		Name
	Common	CCITT		DTE	DCE	
AA		101	1		X	Frame Ground
BA	TXD	103	2	X		Transmit Data
BB	RXD	104	3		X	Receive Data
CA	RTS	105	4	X		Request to Send
CB	CTS	106	5		X	Clear to Send
CC	DSR	107	6		X	Data Set Ready
AB	GND	102	7	X		Signal Ground
CD	DTR	108.2	20	X		Data Terminal Ready
CE	RI	125	22		X	Ring Indicator

Procedure 5-45
Installing the M3000 data terminal

- 1 Connect the RS-232-C interface connector from the data terminal to the Data Option connector in the back of the **M3000** Touchphone.
- 2 Insert the two captive screws in the connector body into the threaded holes in the Data Option connector. Secure tightly to prevent accidental disconnection during data terminal operation.
- 3 Ensure that the Touchphone power supply transformer is plugged in the wall outlet, and connected to the Touchphone.

Tables 5-17 and 5-18 show the connector pin numbers together with the signals associated with each pin as it applies to the standard RS-232-C interface.

Note: If an **ADM3**, **ADM5**, or **ADM11** terminal is used in conjunction with the RS-232-C connector in the Asynchronous Data Option, pin 22 in the RS-232-C cable must be disconnected. The quoted ADM terminals will go into test mode if this pin is not disconnected.

Figure 5-23
M3000 data terminal and DTE/computer terminal connection

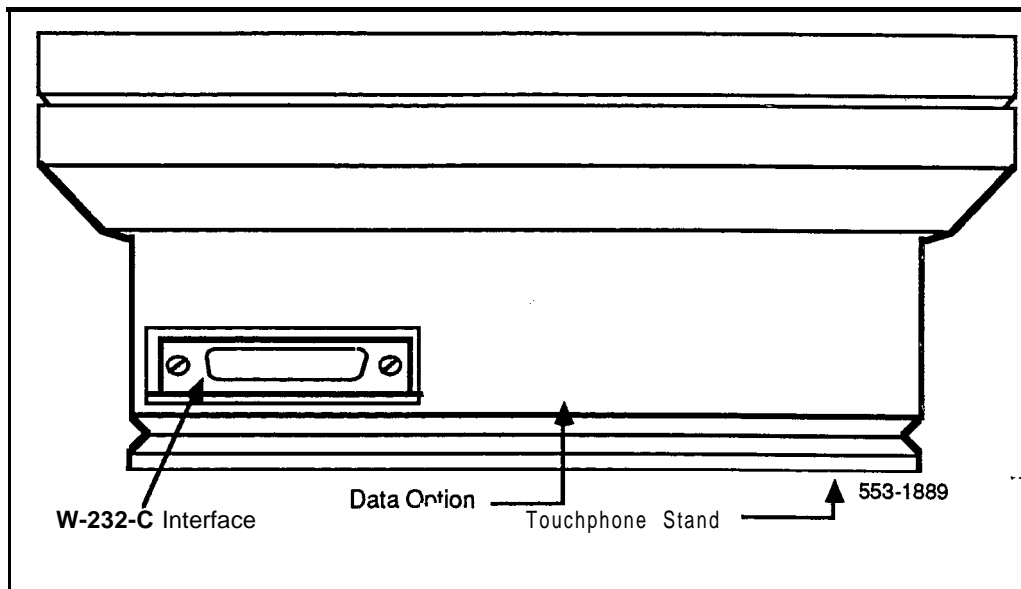

Table 5-17
RS-232-C signals and associated pin numbers for the M3000 Touchphone

EIA	Circuit designation Common	CCITT	Pin number	Signal source		Name
				DTE	DCE	
AA		101	1		X	Frame Ground
BA	TXD	103	2	X		Transmit Data
BB	RXD	104	3		X	Receive Data
CA	RTS	105	4	X		Request to Send
CB	CTS	106	5		X	Clear to Send
cc	DSR	107	6		X	Data Set Ready
AB	GND	102	7	X		Signal Ground
CD	DTR	108.2	20	X		Data Terminal Ready
CE	RI	125	22		X	Ring Indicator

A special 9 pin connector is required to connect the **Apple** Macintosh to the RS-232-C connector in the **M3000** Asynchronous Data Option. See Table 5- 18 for cable connections.

Table 5-1 8
Connections for Apple Macintosh to M3000 Data Option

g-pin connector (from terminal)		25 Pin (RS-232-C) connector (at Data Option port)
Pin 3	to	Pin 7
Pin 5	to	Pin 2
Pin 9	to	Pin 3

Note: Strap pins 4 and 5, and pins 6, 8, and 20 together.

M2006, M2008, M2016S, M2616 and M2216ACD

Use the procedures listed here for adding hardware options to the **M2006**, **M2008**, **M2016S**, **M2616** and **M2216ACD** sets only. These options are available with Release **14+**.

CAUTION

Use only the line cord provided with your Meridian Modular telephone when installing and removing options. The acceptable line cord is A0346862.

Figure S-24 shows an exploded view for reference when dismantling the set to get at its internal components. The M2006 and M2008 set types are slightly smaller than the M2616 and don't have the center screw in the base, but otherwise are the same.

Refer to Figure 5-25 to locate the various components of the **M2006** and **M2008** telephones. Refer to Figure 5-26 to locate components on the **M2016S**, **M2616** and **M2216ACD** telephones.

Figure 5-24
Exploded view of M2616/M2016S/M2216ACD telephone set

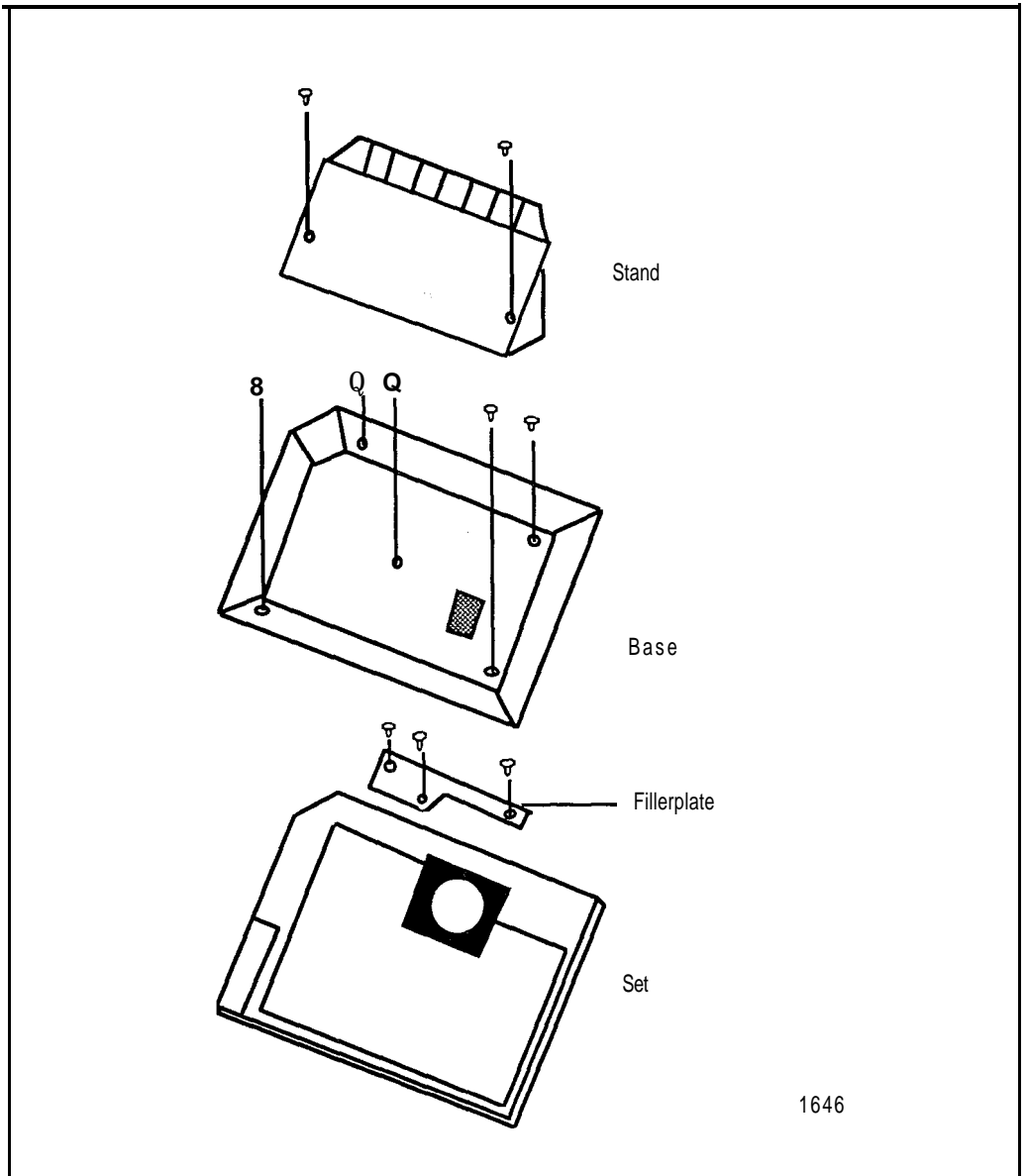

Meridian Programmable Data Adapter

Use the following procedures to add the Meridian Programmable Data Adapter to the telephone and to connect it to your terminal or personal computer.

In all cases, adding the Meridian Programmable Data Adapter to a set requires a Power Supply Board along with an additional power source (see Procedure 5-48 for M2006/M2008, see Procedure 549 for M2016S/M2616/M2216ACD).

Procedure 5-46

Installing and removing the Meridian Programmable Data Adapter

CAUTION:

Before handling internal set components, static electricity must be discharged from hands and tools by touching any grounded metal surface or conductor.

- 1 Remove handset and place telephone upside down on top of a level, solid work surface (e.g. a desktop) covered with soft material or paper to prevent damage to movable keys and the telephone face.
- 2 Disconnect all cords from the telephone.
- 3 Remove the two screws from the stand assembly and unsnap stand assembly by pressing inward at back of stand where it meets the base and pulling upward.
- 4 If the telephone is not equipped with the Meridian Programmable Data Adapter (MPDA), go to step 6. If you wish to replace an existing Programmable Data Adapter, carefully disconnect the end of the 8-pin TELADAPT jack plugged into the set by pressing firmly on the latch-tab and slowly lifting up.
- 5 Turn the telephone stand assembly over and put it in the normal use position. Remove the two self-tapping screws which fasten the MPDA to the telephone stand assembly and remove the MPDA by pulling outward and up. Go to Step 7 to replace the MPDA.

-continued-

- 6 Remove break-out section in rear of the telephone stand assembly, and clean away the small tabs.
- 7 Tilt the Programmable Data Adapter circuit board up and insert the DB-25 connector socket into the breakout section, then slide the board connector end-first under the tabs in stand assembly and position over locating pins. Position and lower completely onto the telephone stand assembly. Insert the two Phillips head, self-tapping screws supplied with the MPDA into the mounting holes and tighten with a #1 Phillips screwdriver.
- 8 Plug one end of an S-conductor line cord supplied with a **TELADAPT** adapter in the jack **J1** of the Programmable Data Adapter (latch tab facing down) and plug the other end of the line cord into the jack of the modular telephone set. Make certain the latch tab of each cable end are firmly snapped into place.
- 9 Carefully route excess cable so that it will not become pinched between the stand and base.
- 10 Reassemble base and stand assembly sections, ensuring that stand is firmly seated to the base.
- 11 Tighten screws, reconnect all cords and place telephone in normal operating position. Place label supplied with the Programmable **Data** Adapter on bottom cover of set for tracking purposes.

Note: If an ADM3, ADM5 or ADM11 terminal is used in conjunction with the DB-25 connector-C connector in the Asynchronous Programmable Data Adapter, pin 22 in the DB-25 connector cable must be disconnected. The quoted ADM terminals will go into test mode if this pin is not disconnected.

Procedure 5-47
Connecting the data terminal

- 1 Connect the DB-25 connector-C interface connector from the data terminal to the matching header connector in the back of the modular telephone.
- 2 Insert the two captive screws in the connector body into the threaded holes in the header connector and secure tightly to prevent accidental disconnection during data terminal operation.

Power Supply Board

Use the following procedures to add a Power Supply Board the telephone, for connection to a transformer or closet power supply. Procedure 5-48 is for the **M2006** and **M2008**. Procedure 5-49 is for the **M2016S**, **M2616**, and **M2216ACD**.

CAUTION

Connect the optional Power Supply to your Meridian Modular Telephone only. Equipment damage may result from incorrect connections. Both the closet power supply, and the transformer are for use with the Meridian Modular Telephone only.

Procedure 5-48 Installing and removing the **M2006/M2008** Power Supply Board

CAUTION:

Before handling internal set components, static electricity must be discharged from hands and tools by touching any grounded metal surface or conductor.

- 1 Remove handset and place telephone upside down on top of a level, solid work surface (e.g. a desktop) covered with soft material or paper to prevent damage to movable keys and the telephone face.
- 2 Disconnect all cords from the telephone.
- 3 Remove the two screws from the stand assembly and unsnap stand assembly by pressing inward at back of stand where it meets the base and pulling upward.
- 4 If the telephone is equipped with a Meridian Programmable Data Adapter (MPDA), unplug data cable from base set jack.
- 5 Remove the four (4) screws securing the base of the telephone set to the top cover. Remove base and set aside.

—continued—

- 6 If the telephone is equipped with Display, disconnect the Display ribbon cable from the Display Board and move out of the way.
- 7 If the telephone is not equipped with the Power Supply Board, remove jumpers from **P1** connector pins on Main Board. Go to step 9.
If the telephone is equipped with a Power Supply Board, go to step 8.
- 8 The Power Supply Board is located on the left side of the set. Remove two (2) small screws from Power Supply Board (near top) and set aside, Grasp Board **firmly** on each side. Work Board loose from connector by slowly applying upward pressure to alternate sides until released.
If you are not replacing the Power Supply Board, place jumpers (A0288529) connecting the bottom two sets of pins on **P1** connector.
- 9 Place Power Supply Board so alignment pin on set **fits** into Slot A on **Board** (see Figure 5-25). Align mounting holes in Board (near top) over mounting holes in set and carefully press down so **H1** connector on Board slides onto **P1** pins.
- 10 Take **the** Phillips head, self-tapping screws supplied with the Power Supply Board and install into the mounting holes. Tighten **firmly** with a #1 Phillips screwdriver.
- 11 If set has a Display, reconnect Display ribbon cable, routing **cable as** described in Procedure 5-50.

Note: Do not allow R5 on Power Board to become bent during this procedure.

- 12 Replace base. If the telephone is equipped with a Programmable Data Adapter, reconnect data cable to the base set jack and replace stand (ensuring Programmable Data Adapter cable does not get pinched between base and stand). Make sure stand is firmly seated to base.
- 13 Tighten all screws, reconnect line cord and place telephone in normal operating position. Place label supplied with the Power Supply option on bottom cover of set for tracking purposes.

Figure 5-25
M2006/2008 set and option boards

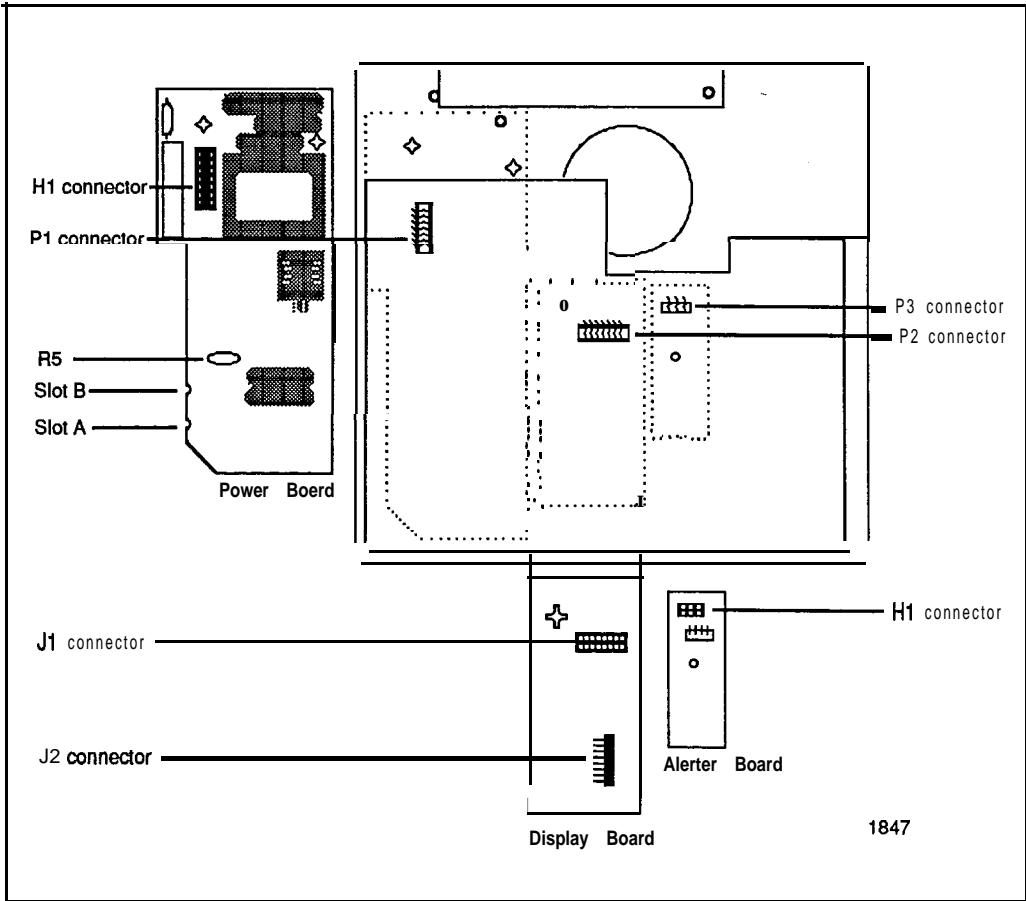
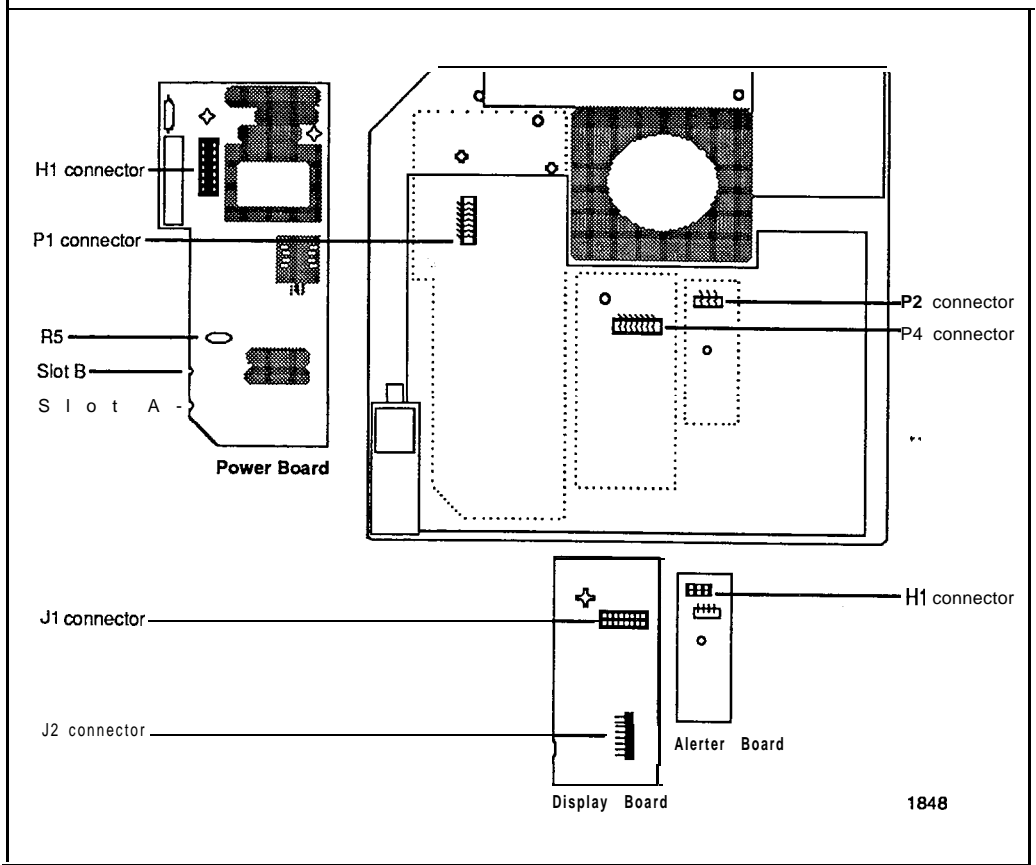

Figure 5-26
M2616/M2016S/M2216ACD set and option boards



1848

Procedure 5-49
Installing and removing the M2016S/M2616/M2216ACD Power Supply

CAUTION:

Before handling internal set components, static electricity must be discharged from hands and tools by touching any grounded metal surface or conductor.

- 1 Remove handset and place telephone upside down on top of a level, solid work surface (e.g. a desktop) covered with soft material or paper to prevent damage to movable keys and the telephone face.
- 2 Disconnect all cords from the telephone.
- 3 Remove the two screws from the stand assembly and unsnap stand assembly by pressing inward at back of stand where it meets the base . . and pulling upward.
- 4 If the telephone is equipped with a Meridian Programmable Data Adapter (MPDA), unplug data cable from base set jack.
- 5 Remove the five (5) screws securing the base to the top cover. Remove base and set aside.
- 6 If the telephone is equipped with Display, disconnect the Display ribbon cable from the Display Board and move out of way.
- 7 If the telephone is not equipped with the Power Supply Board, remove jumpers from **P1** connector pins on Main Board. Go to step 9.
If the telephone is equipped with a Power Supply Board, go to step 8.
- 8 The Power Supply Board is located on the left side of the set. Remove two (2) small screws from Power Supply Board (near top) and set aside. Grasp Board **firmly** on each side. Work Board loose slowly until released.
If you are not replacing the Power Supply Board, place jumpers (A0288529) connecting the bottom two sets of pins on **P1** connector.

—continued—

- 9 Place Power Supply Board so Slot B fits into alignment pin on set (see Figure 5-26). Align mounting holes in Board (near top) over mounting holes in set and carefully press down so **H1** connector on Board slides onto **P1** pins.
- 10 Take the Phillips head, self-tapping screws supplied with the Power Supply Board and install into the mounting holes. Tighten firmly with a **#1** Phillips screwdriver.
- 11 If set has a Display, reconnect Display ribbon cable, routing cable as described in Procedure 5-5 1.

Note: Do not allow **R5** on Power Board to become bent during this procedure.

- 12 Replace base. If the telephone is equipped with a Programmable Data Adapter, reconnect data cable to the base set jack and replace stand (ensuring Programmable Data Adapter cable does not get pinched between base and stand). Make sure stand is firmly seated to base.
- 13 Tighten all screws, reconnect line cord and place telephone in **normal** operating position. Place label supplied with the Power Supply option on bottom cover of set for tracking purposes.

Display

Use the following procedure to add a Display to the telephone. Procedure 50 is for the M2008, Procedure 51 is for the M2016S, M2616, and the M2216ACD.

Procedure 5-50 Installing and removing the M2008 Display

CAUTION:

Before handling internal set components, static electricity must be discharged from hands and tools by touching any grounded metal surface or conductor.

- 1 Remove handset and place telephone upside down on top of a level, solid work surface covered with soft material or paper to prevent damage to movable keys and the telephone face.
- 2 Disconnect all cords from the telephone.
- 3 Remove the two screws from the stand assembly and unsnap stand assembly by pressing inward at back of stand where it meets the base and pulling upward.
- 4 If the telephone is equipped with a Programmable Data Adapter, unplug data cable from base set jack. Remove the four (4) screws securing the base to the set. Remove base and set aside.
- 5 The Power Supply Board (if equipped) is located on the left side of the set. Remove two (2) small screws from Power Supply Board (near top) and set aside. Grasp Board firmly on each side. Carefully work Board loose until released.

-continued-

- 6 If the telephone is not equipped with Display, go to step 9. If the telephone is equipped with Display, go to step 7.

Removing the Display Board

- 7 The Display Board is located at left center of set. Disconnect Display ribbon cable from Display Board. Remove the small screw from Board. Grasp board firmly on each end and pull upward to remove. To replace, go to step 9.

Removing the Display

- 8 Remove three (3) screws from Display module. Remove Display from set. To install Display option, go to step 11.

Installing the Display Board

- 9 Place **J1** connector of Display Board over P2 pins of set (see Figure 5-25). Press down slowly until **J1** slides onto P2 pins and is **firmly** seated.
- 10 Take the Phillips head, self-tapping screw supplied with the Display and insert into the mounting hole (near top). Tighten fiily with a **#1** Phillips screwdriver.

Installing the Display

- 11 Place Display face down near top of set and align the three mounting holes of Display with three mounting holes of set.
- 12 Place the three (3) Phillips head, self-tapping screws from faceplate and insert into the mounting holes: tighten firmly with a **#1** Phillips screwdriver.

—continued—

Note: Do not allow R5 on Power Board to become bent during this procedure.

- 13 Install the Power Board (see Procedure 548).
- 14 Fold ribbon cable near connector to align with J2 pins on Display Board, ensuring that notch on ribbon cable is facing toward the Display Board. Carefully work ribbon cable connector onto J2 pins until firmly seated. Route cable flat beside Power Supply Board, gathering excess cable under the Display. Be careful not to dress cable beneath alignment posts or studs of base.
- 15 Replace base. If the telephone is equipped with a Programmable Data Adapter, reconnect data cable to **the** base set jack and replace stand (ensuring Programmable Data Adapter cable does not get pinched between base and stand). Make sure stand is **firmly** seated to base.
- 16 Tighten all screws, reconnect line cord and place telephone in normal operating position. Place label supplied with the Display on bottom cover of set for tracking purposes.
- 17 Perform the self test (**Procedure 5-55**) and acceptance test procedures. **See** LD 31, **SL-I X11 input/output guide** (553-3001-400).

Procedure 5-51
installing and removing the **M2616/M2016S/M2216ACD Display****CAUTION:**

Before handling internal set components, static electricity must be discharged from hands and tools by touching any grounded metal surface or conductor.

- 1 Remove handset and place telephone upside down on top of a level, solid work surface covered with soft material or paper to prevent damage to movable keys and the telephone face.
- 2 Disconnect all cords from the telephone.
- 3 Remove the two screws from the stand assembly and unsnap stand assembly by pressing inward at back of stand where it meets the base and pulling upward.
- 4 If the telephone is equipped with a Programmable Data Adapter, unplug data cable from base set jack. Remove the five (5) screws securing the base to the set. Remove base and set aside.
- 5 If the telephone is not equipped with Display, go to step 9. If the telephone is equipped with Display, go to step 6.

Removing the Display Board

- 6 The Display Board is located at left center of set. Disconnect Display ribbon cable from Display Board. Remove the small mounting screw from Board. Grasp board firmly on each end and pull upward to remove. To replace, go to step 9.

Removing the Display

- 7 The Power Supply Board is located on the left side of the set. Remove two (2) small screws from Power Supply Board (near top) and set aside. Grasp Board firmly on each side. Carefully work Board loose until released.

—continued—

- 8 Remove **three** (3) screws from Display module. Remove Display from set. To install Display, go to step 11.

Installing the Display Board

- 9 Place **J1** connector of Display Board over P2 pins of set (see Figure 5-26). Press down slowly until **J1** slides onto P2 pins and is fully **seated**.
- 10 Take the Phillips head, self-tapping screw supplied with the Display and insert into the mounting hole (near top). Tighten firmly with a **#1** Phillips screwdriver.

Installing the Display

- 11 Place the three (3) Phillips head, self-tapping screws from the faceplate and insert into the mounting holes; tighten fully with a **#1** Phillips screwdriver.
- 12 Install the Power Board (see Procedure 5-49). This step not necessary on M2616 unless you have other hardware options.
- 13 Fold ribbon cable near connector to align with J2 pins on Display Board, ensuring that notch on ribbon cable is facing toward the Display Board. Carefully work ribbon cable connector onto **J2** pins until firmly seated. Route cable flat beside Power Supply Board, gathering excess cable under the Display. Be careful not to dress cable beneath alignment posts or studs of base.

Note: Do not allow **R5** on Power Board to become bent during this procedure.

- 14 Replace base. If the telephone is equipped with a Programmable Data Adapter, reconnect data cable to the base set jack and replace stand (ensuring Programmable Data Adapter cable does not get pinched between base and stand). Make sure stand is firmly seated to base.
- 15 Tighten all screws, reconnect line cord and place telephone in normal operating position. Place label supplied with the Display on bottom cover of set for tracking purposes.
- 16 Perform the self test (see Procedure 5-55) and acceptance test procedures. See LD 31, **SL-1 X11 input/output guide** (553-3001-400).

Figure 27
Display cable routing

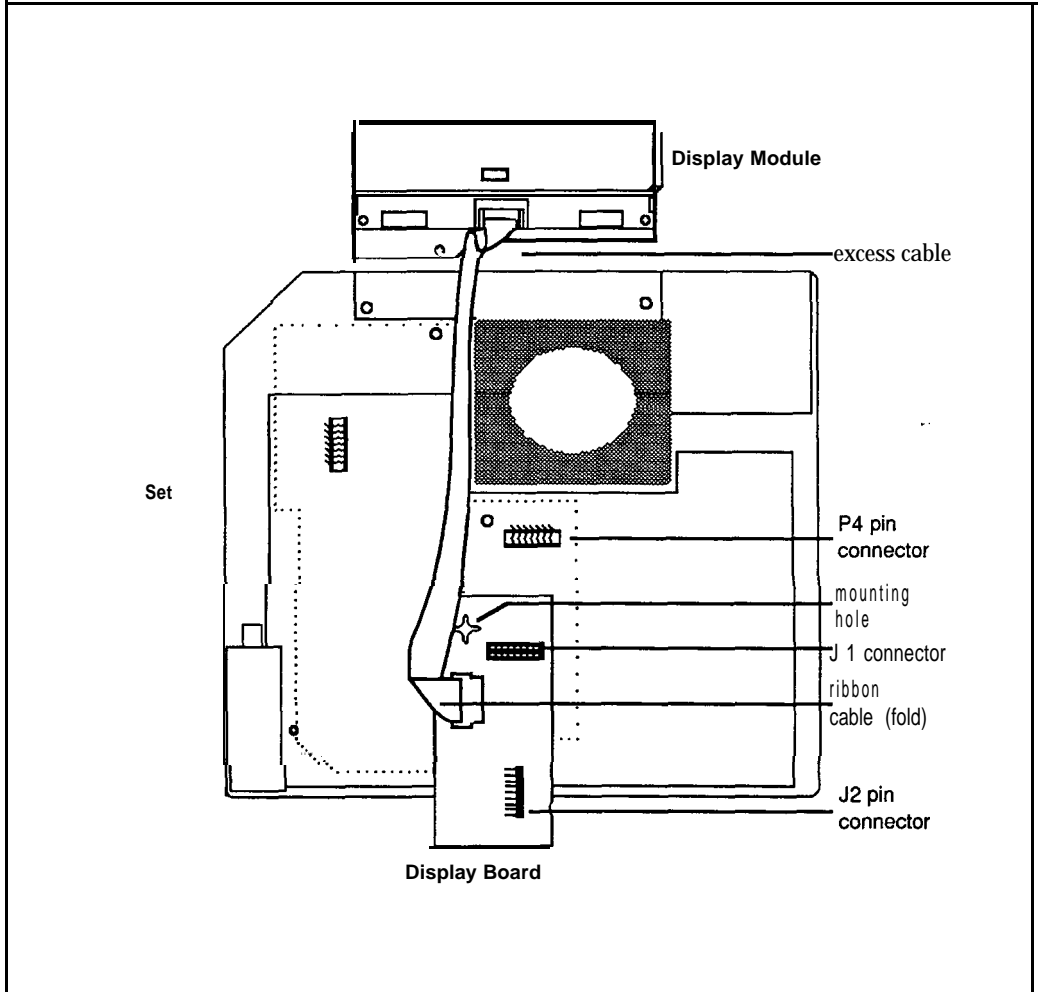

External Alerter Board

Use this procedure to add an External Alerter Board to the **M2006, M2008,** or M2616 telephone. See Figure 5-28 for information on hooking up the third-party External Alerter device.

Procedure 5-52

Installing and removing the External Alerter

CAUTION:

Before handling internal set components, static electricity must be discharged from hands and tools by touching any grounded metall surface or conductor.

- 1 Remove handset and place telephone upside down on top of a level, solid work surface covered with soft material or paper to prevent damage to movable keys and the telephone face.
- 2 Disconnect all cords from the telephone.
- 3 Remove the two screws from the stand assembly and unsnap stand assembly by pressing inward at back of stand where it meets the base and pulling upward.
- 4 If the telephone is equipped with a Meridian Programmable Data Adapter (**MPDA**), unplug data cable from base set jack.
- 5 Remove the four (4) screws securing the base of the telephone set to the top cover. Remove base and set aside.
- 6 If the telephone is not equipped with the External Alerter, go to step 8. If you wish to replace an existing External Alerter, go to step 7.

Removing the External Alerter

- 7 The External Alerter Board is located at right-center of set. Remove screw from Board. Grasp board **firmly** on each end and pull upward to remove.

--continued--

Installing the External Alerter

- 8 Place **H1** connector of Alerter Board over P3 pins of telephone set (see Figure 5-25 for **M2006/M2008**; see Figure 5-26 for **M2616/M2216ACD**). Align mounting hole over mounting post. Carefully work **H1** onto P3 pins **until firmly** seated. Place the Phillips head, self-tapping screw supplied with the External Alerter into mounting hole and tighten with a **#1** Phillips screwdriver.
- 9 To signal the External Alerter when the set's handset or speaker is active, place jumpers (A0288529) connecting the two right-most pins on the Alerter Board.

To signal the External Alerter when the set is ringing or buzzing, place jumpers connecting the two left-most pins on the Alerter Board.
- 10 If the telephone set is not yet equipped with the power Board, install the Power Board (see Procedure 5-48 for **M2006/M2008**; see Procedure 5-49 for **M2616/M2016S/M2216ACD**).

Note: Do not allow R5 on Power Board to become bent during this procedure.

- 11 Replace base. If the telephone is equipped with a Programmable Data Adapter, reconnect data cable to the base set jack and replace **stand** (ensuring Programmable Data Adapter cable does not get pinched between base and stand). Make sure stand is firmly seated to base.
- 12 Tighten all screws, reconnect line cord and place telephone in normal operating position. Place label supplied with the External Alerter on bottom cover of set for tracking purposes.
- 13 For connecting block configuration see Figure 5-28.
- 14 Perform the self test (see Procedure 5-55) and acceptance test procedures. See LD 3 1, **SL-1 XI | input/output guide (553-3001-400)**.

Figure 5-28
External Alerter connecting block configuration

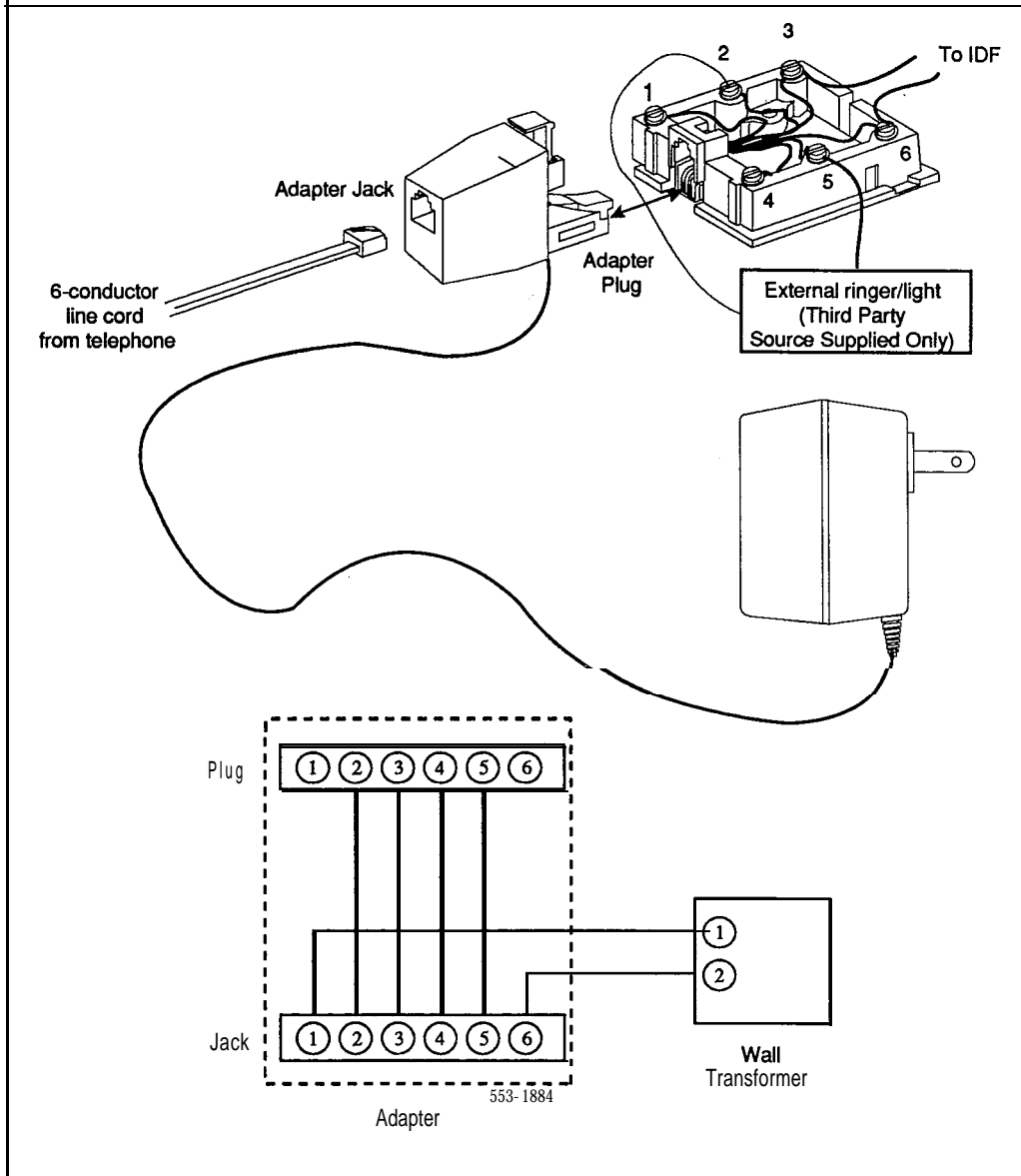

Key Expansion Modules

Use this procedure to add one (single) or two (double) Key Expansion Modules to the **M2016S**, **M2616**, or **M2216ACD** telephones.

Note 1: Before installing the Key Expansion Module(s), you must have the associated Footstand.

Note 2: Adding a Key Expansion Module to a set requires a Power Supply Board along with an additional power source (see Procedure 5-48 for **M2006/M2008**, see Procedure 5-49 for **M2016S/M2616/M2216ACD**).

Procedure 5-53

Installing and removing Key Expansion Module(s) on the **M2016S**, **M2616**, and **M2216ACD** telephones

- 1 Remove handset and place telephone upside down on top of a level, solid work surface covered with **soft** material or paper to prevent damage to movable keys and the telephone face.
- 2 Disconnect all cords from the telephone.
- 3 Remove the two screws from the stand assembly and unsnap stand assembly from the set by pressing inward at back of stand where it meets the base and pulling upward.

Note: If the **M2616/M2016S** is equipped with a Programmable Data Adapter, it must be removed and installed into the Key Expansion Module **Footstand**. Follow Procedure 5-46, "Installing and removing the Meridian Programmable Data Adapter."

- 4 If the telephone is not equipped with Key Expansion Module(s), go to step 7. If you are replacing the Key Expansion Module(s), go to step 5.

—continued—

Removing the Key Expansion Module(s)

- 5 Remove screws **from stand** assembly (where it meets Key Expansion Module) and unsnap stand assembly from Key Expansion Module and set by pressing **inward** at back of stand where it meets the base and pulling upward.
- 6 Remove interface cable from set by pressing down on the locking tab. If equipped, remove interface cable from 1st Key Expansion Module (closest to telephone set).

installing the Key Expansion Module(s)

- 7 If the telephone set is not yet equipped with the Power Board, **install the** Power Board (see Procedure 549).
- 8 Align bottom of Key Expansion Module(s) to bottom of telephone set (see Figure 5-29).
- 9 Snap ribbon cable connector(s) into bottom interface jack on the Key Expansion Module. Snap other end of ribbon cable into interface jack in set (left side). Gather excess cable in base of the Key Expansion Module.
- 10 To add a second Key Expansion Module, snap a second ribbon cable connector into the bottom interface jack on the second Key Expansion Module. Snap other end of ribbon cable into top interface jack on first Key Expansion Module (see Figure 5-29). Gather excess cable in base of the second Key Expansion Module.
- 11 If the telephone set is equipped with a Programmable Data Adapter, reconnect data cable to the base set jack. Make sure Programmable Data Adapter cable (and interface cable) does not get pinched between base and stand.

—continued—

- 12 Secure Footstand to Key Expansion **Module(s)** and set by placing tabs of Footstand into slots provided on the base of Key Expansion Module and set and pressing down. Make sure stand is firmly seated to base. Ensure ribbon cable(s) are not pinched between the **Footstand** and mounting posts.
- 13 Insert the three (four if you have two Modules) self-tapping Phillips head screws supplied with the Key Expansion Module into the mounting holes in bottom of Footstand. Tighten **firmly** with a #1 Phillips screwdriver.
- 14 Tighten all screws and replace all cords; place telephone in normal operating position. Place label supplied with the Key Expansion Module(s) on bottom cover of set (or Footstand) for tracking purposes.
- 15 Perform the self test (see Procedure **5-55**) and acceptance test procedures. See LD **31, SL-1 X11 input/output** guide (553-3001-400).

Figure 5-29
Key Expansion Module connections (bottom view)

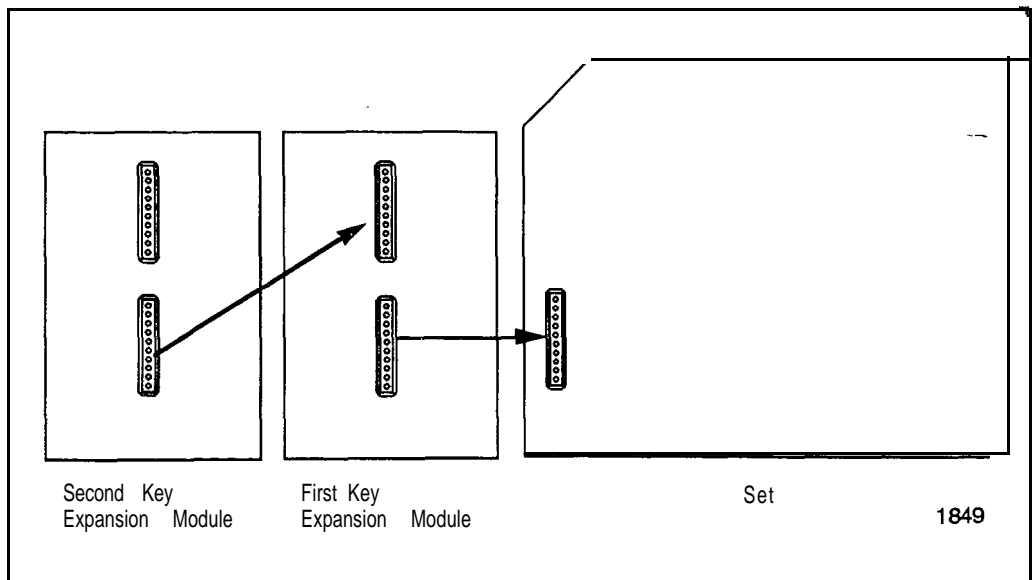

Wall mounting

The **M2006**, **M2008**, M2616 and the **M2016S** Digital Telephones are equipped with a reversible footstand which allows for wall mounting.

Note: The footstand cannot be reversed for wall mounting if the Power Supply Board is used with an external transformer.

An additional clip is provided for wall mounting. This clip is attached to the switchhook rest to prevent the handset from slipping when mounted on the wall.

Procedure 5-54

Wall mounting instructions for Meridian Modular Telephones

- 1 Remove handset and place telephone upside down on top of a level, solid work surface covered with soft material or paper to prevent damage to movable keys and the telephone face.
- 2 Disconnect all cords from the telephone.
- 3 Remove the two screws from the stand assembly and unsnap stand assembly by pressing inward at back of stand where it meets the base and pulling upward.
- 4 Rotate the footstand 180° and snap the footstand back into place on the telephone bottom cover. Make sure stand is **firmly** seated to base of telephone set.
- 5 Tighten all screws and replace all cords.
- 6 Insert wall-mounting clip in switchhook rest.
- 7 Mount telephone on wall using wall mount holes provided on the bottom of the footstand.

Self test

Meridian Modular Telephones have a self testing capability. Perform the self test after installing a Meridian Modular Telephone or any of the hardware options to assure proper **operation**.

Procedure 5-55

Meridian Modular Telephones self test

- 1 Unplug the line cord **from** the telephone set.
- 2 While holding down the RLS key, plug in the line cord to the telephone set. **Let go of the RLS key.**
- 3 Use Table 5-19 to perform the necessary steps and check results.

Table 5-19

Self test steps and results

Step	Action	Result	..
1	Begin test (plug in line cord while holding down RLS key). Handset is on-hook.	Speaker beeps once, all LCDs flash, Message Waiting lamps lights steadily, Display reads: LOCAL DIAGNOSTIC MODE PRESS RLS KEY TO EXIT	
2	Press each function key, from zero to fifteen (if you have Key Expansion Modules, continue pressing the function keys, in any order).	Adjacent LCD goes off when key is pressed. ^{1,2}	
3	Press HOLD key.	Speaker beeps.	
4	Press each dialpad key.	Speaker beeps each time a key is pressed.	
5 a	Lift handset (if applicable). Press dialpad keys. Replace handset.	Speaker beeps. Handset beeps.	
5 b	Plug in headset (if applicable). Press dialpad keys. Unplug headset.	Speaker beeps. Headset beeps.	

—continued—

Table 5-19 (continued)
Self test steps and results

Step	Action	Result
6	Press right side of volume control key.	Speaker beeps, Display is filled with dark-squares.
	Press right side of volume control key.	Speaker beeps, Display is blank.
	Press right side of volume control key.	Speaker beeps, Display shows symbols including digits O-Q and upper-case alphabet
	Press right side of volume control key.	Speaker beeps, Display shows symbols including upper- and lower-case alphabet.
	Press right side of volume control key.	Speaker beeps, Display shows various symbols,
	Press right side of volume control key.	Speaker beeps, Display shows symbols.
	Press right side of volume control key.	Speaker beeps, Display is filled with dark squares.
7	Press RLS key (end of test).	Message Waiting lamp goes off, Display shows idle screen within 10 seconds.

Troubleshooting

Use Table 5-20 to check problems encountered when installing Meridian Modular Telephones and their options.

Table 5-20
Troubleshooting Meridian Modular Telephones

Symptom	Solution
Telephone set doesn't work.	<ol style="list-style-type: none"> 1 Unplug line cord from telephone set and plug back in. 2 If the set uses external power, make sure transformer or closet power supply is properly connected and that Power Supply Board is properly installed. If the set does not use external power, make sure that jumpers are placed connecting the bottom two sets of pins on P1 connector on main circuit board.
All LCDs flash and telephone set doesn't function.	<ol style="list-style-type: none"> 1 Press Release (RLS). 2 Unplug line cord from telephone set and plug back in.
Telephone set wobbles.	<ol style="list-style-type: none"> 1 Ensure all cords are properly routed through channels in the footstand. 2 Check that footstand is firmly seated to the telephone set. 3 Ensure that all feet are firmly seated in the footstand.
Display doesn't work.	<ol style="list-style-type: none"> 1 Unplug the line cord from telephone set and plug it in again. 2 Ensure transformer is plugged in or closet power is connected (M2008 only). 3 Ensure Power Board is installed properly (M2008 only). 4 Check that Display ribbon cable is properly connected to the Display Board and has not been pinched. 5 Ensure Display Board is installed correctly and held securely with a mounting screw. <p style="text-align: center;">-continued-</p>

Table 5-20 (continued)
Troubleshooting Meridian Modular Telephones

Symptom	Solution
Meridian Programmable Data Adapter doesn't work.	<ol style="list-style-type: none"> 1 Check LED in back of set to see if it's flashing (if steady, MPDA needs to be configured in system or is bad; if not lit, telephone set needs external power). 2 Ensure that data cable from your terminal or PC is connected to the MPDA. 3 If you have Display, check data parameters using <i>Meridian Programmable Data Adapter User Guide (PO705986)</i>. 4 Ensure transformer is plugged in or closet power is connected. 5 Check that the cable from the MPDA is connected to the set and has not been pinched. 6 Ensure Power Board is installed properly.
Key Expansion Module doesn't work.	<ol style="list-style-type: none"> 1 Ensure that transformer is plugged in or that closet power supply is connected. 2 Ensure Power Board is installed properly. 3 Make sure ribbon cable connecting telephone set and Key Expansion Module is routed properly and is not pinched.
External Alerter doesn't work.	<ol style="list-style-type: none"> 1 Ensure Alerter Board is installed properly. 2 Check that connections between the alerting device and the telephone set connecting block are correct. 3 Make sure that jumpers are placed on the pins on Alerter Board as described in Procedure 5-52. 4 Ensure transformer is plugged in or closet power is connected. 5 Ensure Power Board is installed properly.



SL-1
**Telephone sets and attendant
consoles**

Installation procedures

Copyright © 1984 Northern Telecom
All rights reserved.
Information subject to change without notice.
Release 1.0
Standard
December 20, 1989
Printed in U.S.A.



553-3001-500

SL-1

System options 21, 51, 61, 71

General maintenance information
Standard

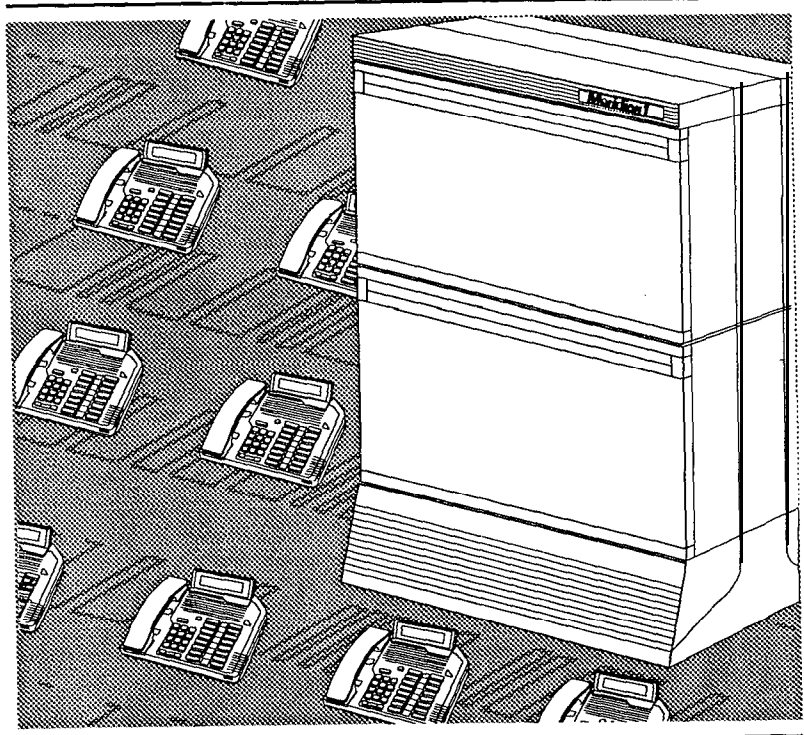

nt northern
telecom

Meridian 1
Communication Systems





SL-1

System options 21, 51, 61, 71

General maintenance information

Publication number: 553-3001-500

Document release: 2.0

Document status: Standard

Date: February 28, 1990



© 1990 Northern Telecom

All rights reserved.

General maintenance information 553-3001-500

Revision history

January 29, 1990

Standard, release 1.0

February 28, 1990

Standard, release 2.0

Contents

About this document	1
References	2
<hr/>	
Precautions	3
Chapter contents	3
Introduction	3
Circuit cards	4
Data disks	5
<hr/>	
Communicating with the system	7
Chapter contents	7
Introduction	7
System terminal	8
Software format	8
Local and remote access	9
Maintenance display codes	10
Maintenance telephone	12
<hr/>	
Routine maintenance	13
Chapter contents	13
Introduction	13
Batteries	13
Air filters	14

Hardware maintenance tools	17
Chapter contents	17
Introduction	18
Circuit card features	18
Self-tests	18
Enable/disable switches	19
LEDs	20
CPU controls	22
initialize button	22
Normal/maintenance switch	22
Reload button	24
System alarms	26
Major alarms	26
Minor alarms	26
Remote alarms	26
System Monitor indicators	28
NT7D15AA System Monitor	28
NT8D22AB System Monitor	29
Line transfer	31
Main power loss	32
UEM power supply failure	33
Temperature alarms	35

Software maintenance tools	37
Chapter contents	37
Introduction	37
Diagnostic programs	38
Error Monitor	38
Initialize Program	39
Midnight and Background Routines	39
Overlay Loader	41
Overload Monitor	41
Resident Trunk Diagnostic	41
System Loader	42
History File	43
Interactive diagnostics	44
Enhanced Maintenance	44
Manual Continuity Tests	45

User reports **49**

Customer technical assistance service **51**

Chapter contents 51

Introduction 51

Services available 53

Requesting assistance 56



About this document

This document describes maintenance features for SL- 1 system options 21, 51, 61 and 71. The chapters in this document tell you about

- Precautions: guidelines to avoid damaging circuit cards and data disks.
- Communicating with the system: methods for exchanging information with the system.
- Routine maintenance: requirements for servicing batteries and air filters.
- Hardware maintenance tools: descriptions of circuit card hardware, CPU controls, system alarms, and System Monitor indicators.
- Software maintenance tools: descriptions of diagnostic programs, the History File, and interactive diagnostics.
- User reports: lists problems that are typically reported by users.
- Customer technical assistance service: lists Northern Telecom Technical Assistance Centers and services.

This document does not provide procedures for locating faults, clearing faults, or replacing equipment. See **Fault clearing** (553-3001-510) to locate and clear faults. See **Hardware replacement** (553-3001-520) to replace faulty equipment.

References

See the *SL-1 planning and engineering guide* for

- *Master index* (553-3001-000)
- *System overview* (553-3001-100)
- *Spares planning* (553-3001-153)
- *Equipment identification and ordering* (553-3001-154)

See the list of line and trunk circuit descriptions in the *Master index* (553-3001-000) for specific references to lines and trunks.

See the *SL-1 installation and maintenance guide* for

- *System installation procedures* (553-3001-210)
- *Circuitpack installation and testing* (553-3001-211)
- *Installation procedures for telephone sets and attendant consoles* (553-3001-215)
- *Fault clearing* (553-3001-510)
- *Hardware replacement* (553-3001-520)

See the *SL-1 XI1 software guide* for an overview of software architecture, procedures for software installation and management, and a detailed description of all XI 1 features and services. This information is contained in two documents:

- *XI1 software management* (553-3001-300)
- *XI1 features and services* (553-3001-305)

See the *SL-1 XI1 input/output guide* (553-3001-400) for a description of all administration programs, maintenance programs, and system messages.

Precautions

Chapter contents

introduction	3
Circuit cards	4
Data disks	5

Introduction

SL-1 equipment is based on solid state circuitry which is sensitive to static electricity and environmental conditions. Follow the precautions in this chapter to avoid equipment damage.

Covers on Universal Equipment Modules (**UEMs**) are *not* hinged. When you remove a cover, do not let go of the cover. Lift the cover away from the UEM and set it out of your work area.

3

Circuit cards

Handle cards in the following ways:

- Touch the metal frame of the equipment column to discharge static electricity **from** your body before handling any circuit pack.
- Handle cards by the card stiffeners and edges only. Do not touch the contacts or components.
- Keep cards installed in the system as much as possible to avoid dirty contacts and unnecessary wear.
- Set cards on a protective antistatic bag. If an antistatic bag is not available, hand-hold the card, or set it in a card cage unseated from the connectors.
- Unpack or handle cards away from electric motors, transformers, or similar machinery.
- Store cards in protective packing in a dry dust-free area.

During repair and maintenance procedures:

- Insert cards into only a compatible slot in an appropriate UEM.
- Turn off the circuit breaker or switch for a UEM power supply before the power supply is removed or inserted.

Note: In AC-powered systems, capacitors in the power supply must discharge. Wait five full minutes between turning off the circuit breaker and removing the power supply from the UEM.

- Software disable cards, if applicable, before they are removed or inserted.
- Hardware disable cards, whenever there is an enable/disable switch, before they are removed or inserted.
- Return defective or heavily contaminated cards to a repair center. Do not try to repair or clean them.

Data disks

Make sure disks are labeled with the generic and issue number when you remove them from the system.

Follow the precautions below to avoid damaging disks:

- Handle only the hard surface of the disk; never touch the recording surface.
- Keep disks away from strong magnetic fields.
- Avoid exposing disks to extreme heat, rapid changes in temperature, or high humidity.
- Store disks in a suitable container.

Before installing a new disk:

- Check the disk identification to make sure it is the correct disk. Compare software options with the data cartridge.
- Look for any damage to the disk.

For more detailed information on data disks, see *XII software management (553-3001-300)*.

6 Precautions



Communicating with the system

Chapter contents

Introduction	7
System terminal	8
Software format	8
Local and remote access	9
Maintenance display codes	10
Maintenance telephone	12

Introduction

You can exchange information with **the** SL-1 through **system terminals** and the **maintenance telephone**. You can receive status and fault indications through **maintenance display** codes. This chapter describes these tools for communicating with the system.

System terminal

You can send maintenance commands and receive system messages by accessing the CPU through an RS-232 device, such as a video display terminal (VDT).

Software format

Through the system terminal, you can enter commands that tell the system to perform specific tasks; the system performs the tasks and sends messages back to the system terminal, indicating status or errors. System messages, along with indicators such as maintenance display codes and LED indicators, identify faults in the system.

System messages are codes with a mnemonic and number, such as PWRO014. The mnemonic identifies a software program or a type of message. The number identifies the specific message. Table 1 gives an example of the format for a system message.

See the XII input/output guide (553-3001-400) for a description of all maintenance commands and the interpretation of all system messages.

Table 1
System message format

System message:	Interpretation
PWRO014	
PWR	the message concerns power equipment or information generated by the System Monitor
0014	this message means the System Monitor failed a self-test

Local and remote access

Although only one device can communicate with the system at a time, many devices can be installed at **local** and remote locations. When a system terminal is installed locally, it is connected directly to a Serial Data Interface (SDI) Card, located within a **UEM**. When a system terminal is installed at a remote location, modems (or data sets) and a telephone line are required between the terminal and the **SDI Card**. Figure 1 shows typical system terminal configurations.

To access the SL-1 through a system terminal, see “Access through the system terminal” in Fault *clearing* (553-3001-510) or Hardware *replacement* (553-3001-520).

Figure 1
Local and remote access to a system terminal

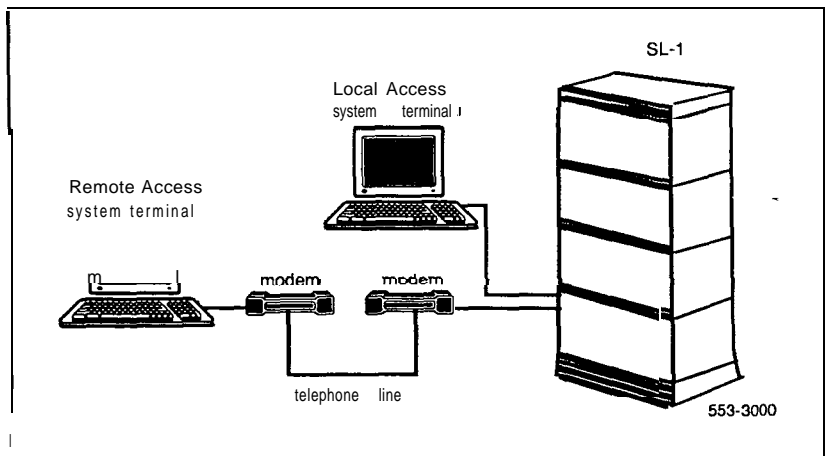

Maintenance display codes

Maintenance displays are located on the faceplate of certain SL-1 circuit cards. Figure 2 shows the location of the maintenance display on the faceplate of a Floppy Disk Interface Card. A maintenance display code is a one, two, or three digit alphanumeric code which can indicate the status of the system and identify faulty equipment.

Interpretations of maintenance display codes are listed under "HEX" in the *X11 input/output guide* (553-3001-400). You should examine previous codes, system messages, and visual indicators with any current maintenance display codes to properly analyze faults.

Each new code shown on a maintenance display overwrites the one before it. However, all codes received on Common Equipment displays are recorded. You can review them by printing the History File (if equipped).

The most recent 16 codes displayed on a Controller Card stay in memory. You can review them and reset the counter through the Network and Signaling Diagnostic (LD 30).

Table 2 lists the cards with maintenance displays and the type of information indicated by the codes on each card.

Table 2
Circuit cards with maintenance displays

Circuit card	System options	Display indicates
CPU Interface Card (QPC580)	. 51, 61, 71	. Sysload status . Interrupt faults
Memory/Peripheral Signaling Card (NT8D19AA)	. 21	. Memory faults . Common Equipment hardware faults
Floppy Disk interface Card (QPC742)	. 21, 51, 61, 71	. Faults on the Floppy Disk Interface Card or Floppy Disk Unit
Mass Storage Interface Card (QPC584)	. 51, 61, 71	. Faults on the Mass Storage Interface Card or Multi Disk Unit
Controller Card (NT8D01AC or NT8D01AD)	. 21, 51, 61, 71	. Controller Card status

Figure 2
Sample maintenance display

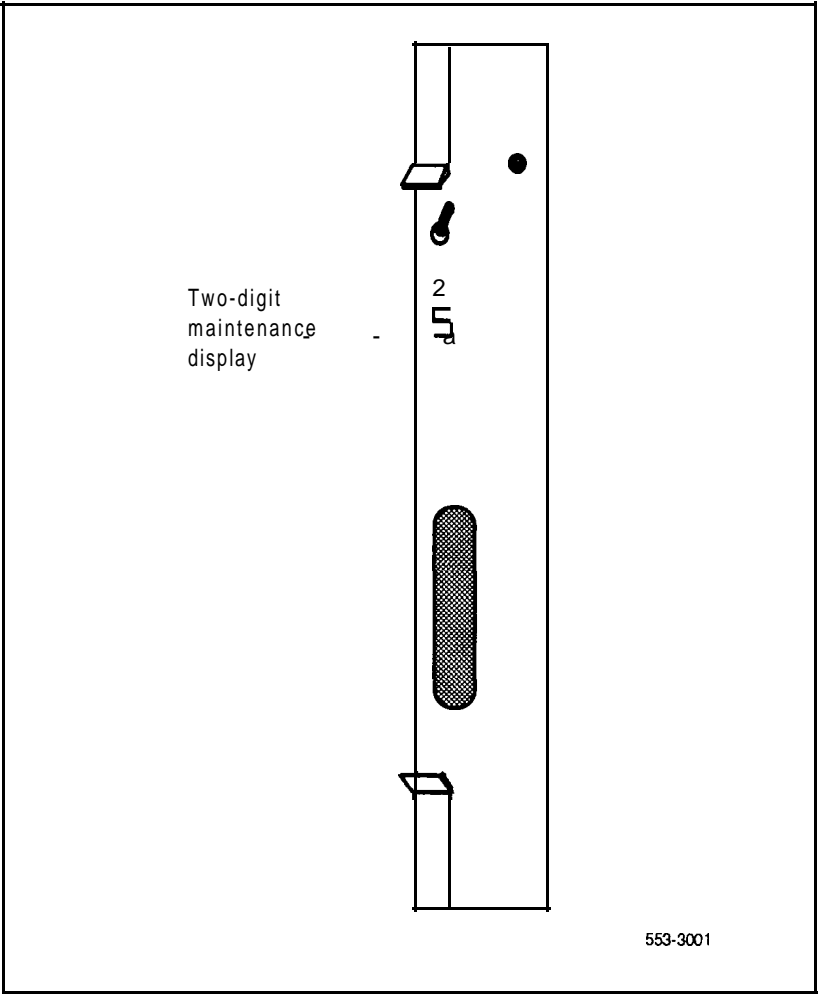

Maintenance telephone

A telephone set functions as a maintenance telephone when you define the class-of-service as MTA (maintenance set allowed) in the SL-1 Telephone Sets program (LD 11). A maintenance telephone allows you to send commands to the system, but you can only use a subset of the commands that can be entered from a system terminal. The maintenance telephone, however, takes priority over a system terminal and will log the terminal out.

You can test tones and outpulsing through the maintenance telephone. Specific commands for those tests are given in the Tone and Digit Switch and Digitone Receiver Diagnostic (LD 34).

To enter commands on a maintenance telephone, you press the keys that correspond to the letters and numbers of the command (for example, to enter LB 42 return, key in **53#42##**). Table 3 shows the translation from a terminal keyboard to a telephone dial pad.

To access the SL-1 through a maintenance telephone, see “Access through the maintenance telephone” in **Fault clearing (553-3001-510)** or **Hardware replacement (553-3001-520)**.

Table 3
Translation from keyboard to dial pad

Keyboard			Dial pad
			1
A	B	C	2
D	E	F	3
G	H	I	4
J	K	L	5
M	N	O	6
P	R	S	7
T	U	V	8
w	x	Y	9
			0
		Space or #	#
		Return	##

Note: There is no equivalent for Q or Z on a dial pad.

Routine maintenance

Chapter contents

Introduction	13
Batteries	13
Air filters	14

Introduction

You must service batteries and air filters regularly. Follow the guidelines in this chapter to maintain batteries and air filters.

Batteries

Batteries generally require regular visual inspections. They may also require charger or rectifier tests and pilot cell tests. Perform all inspections and tests according to the supplier's instructions.

Air filters

There is an air filter in the pedestal of each column (except in system option 21A). Figure 3 shows the location of the air filter in the pedestal. **Once** each month, you should remove air filters and install clean ones (see Procedure 1). If an air filter is damaged in any way, discard it and install a new one. Replace all used air filters at least once a year.

If a dirty air filter is not damaged, you can clean it with warm water and mild detergent, (Do not use compressed air because it may damage the filter.) When the filter is **completely** dry, you can reinsert it in the pedestal or store it as a spare.

Figure 3
Air filter in the pedestal

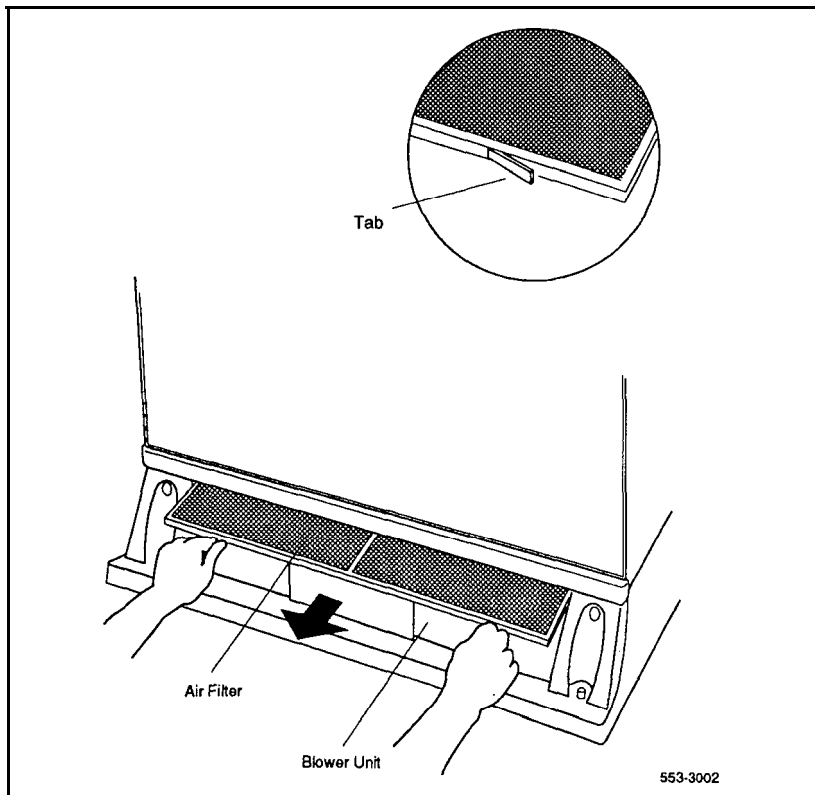

Procedure 1 Replacing air filters

Note: You do not need to power down the system to perform this procedure.

- 1 Grasp the ridges on the outside upper edges of the pedestal front grill. Pull away from the pedestal. Set the grill aside.
- 2 Grasp the plastic tabs on the front of the air filter. Pull the filter out of the pedestal.
- 3 Install a clean, dry air filter. Gently push the filter into the pedestal slot until it seats fully in the back.
 - The air flow indicator etched on the frame must point up.



Air flow indicator

553-3049

- The center strap must be on top.
- The plastic tabs must be on the front.

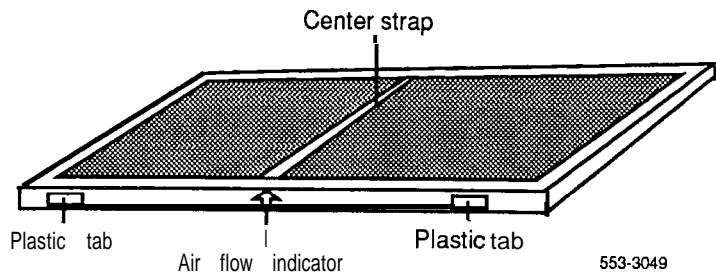

- 4 Fit the bottom of the grill into the holes on the bottom edge of the pedestal. Push the grill into a locked position against the pedestal.



Hardware maintenance tools

Chapter contents

Introduction	18
Circuit card features	18
Self-tests	18
Enable/disable switches	19
LEDs	20
CPU controls	22
Initialize button	22
Normal/maintenance switch	22
Reload button	24
System alarms	26
Major alarms	26
Minor alarms	26
Remote alarms	26
System Monitor indicators	28
NT7D15AA System Monitor	28
NT8D22AB System Monitor	29
Line transfer	31
Main power loss	32
UEM power supply failure	33
Temperature alarms	35

Introduction

There are SL-1 fault indicators and hardware features which help you perform maintenance tasks (particularly identifying and clearing faults). These maintenance tools include:

- Circuit card features: perform self-tests, indicate status, and minimize adverse affects on call processing.
- CPU controls: allow you to control Common Equipment functions.
- System alarms: categorize the severity of a system failure.
- System Monitor indicators: identify power and temperature faults.

Circuit card features

Circuit card features include:

- self-tests
- Light Emitting Diode (LED) indicators
- enable/disable switches

Self-tests

A self-test checks to see that a card is working correctly. Many cards in the SL-1 perform a self-test on power up. You can also force a self-test on a card through software commands. The results of a self-test generally show whether or not there is a problem with the card.

Enable/disable switches

Some cards have a switch on the faceplate that enables or disables the hardware for that card. Figure 4 shows a typical location for an enable/disable (ENB/DIS) switch on the faceplate.

If you remove a card, whenever possible disable the software, then set the switch to disable to disable the hardware. When you install a card, set the switch to enable, then enable the software.

Figure 4
Sample enable/disable switch

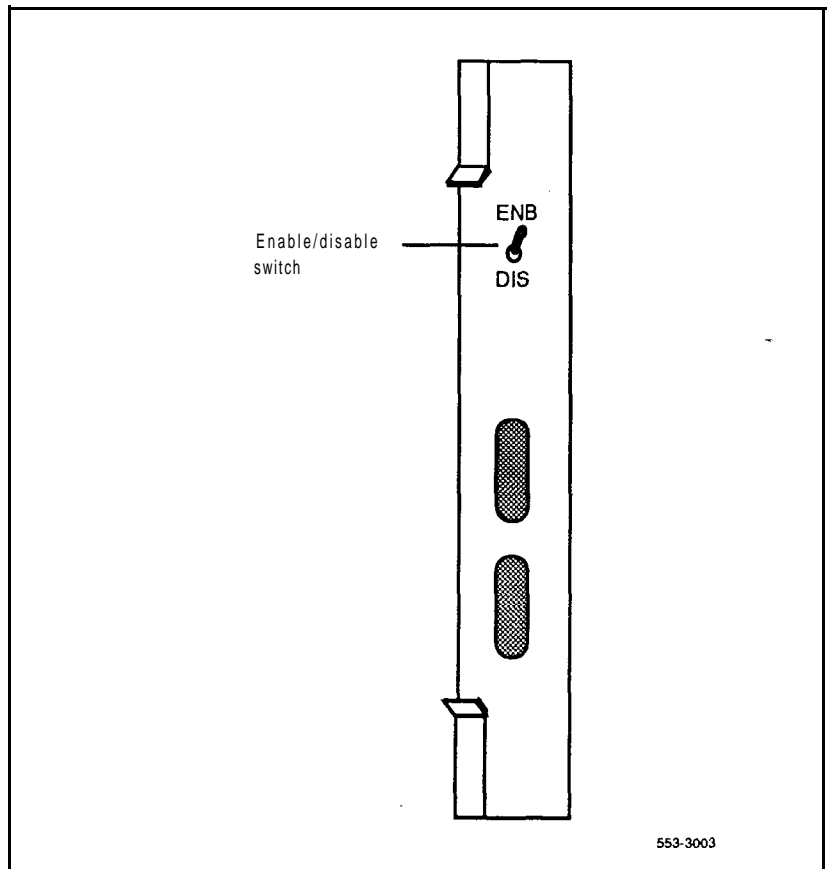

LEDs

Many cards have one or more Light Emitting Diodes (**LEDs**) on the faceplate. Figure 5 shows the location of the LED on the faceplate of an Analog Message Waiting Line Card. The LED gives a visual indication of the status of the card or of a unit on a card.

Note: Some **LEDs** are round, some are square: their function is identical.

When a green LED is steadily lit, it indicates that the card is operating normally. When a red LED is steadily lit, it indicates that the card, or a unit on it, is disabled. Table 4 gives two examples of LED indications.

When Intelligent Peripheral Cards are installed, **the** LED flashes as a self-test runs. If the self-test completes successfully, the card is automatically enabled, if the card is configured in software, and the LED goes out. If the self-test fails, the LED lights steadily and remains lit.

Table 4
Sample LED indications

Type of card	LED color	Status
Common Equipment Power Supply	green	LED lit = operation normal
Digital Line Card	red	LED lit = disabled

Figure 5
Sample LED indicator

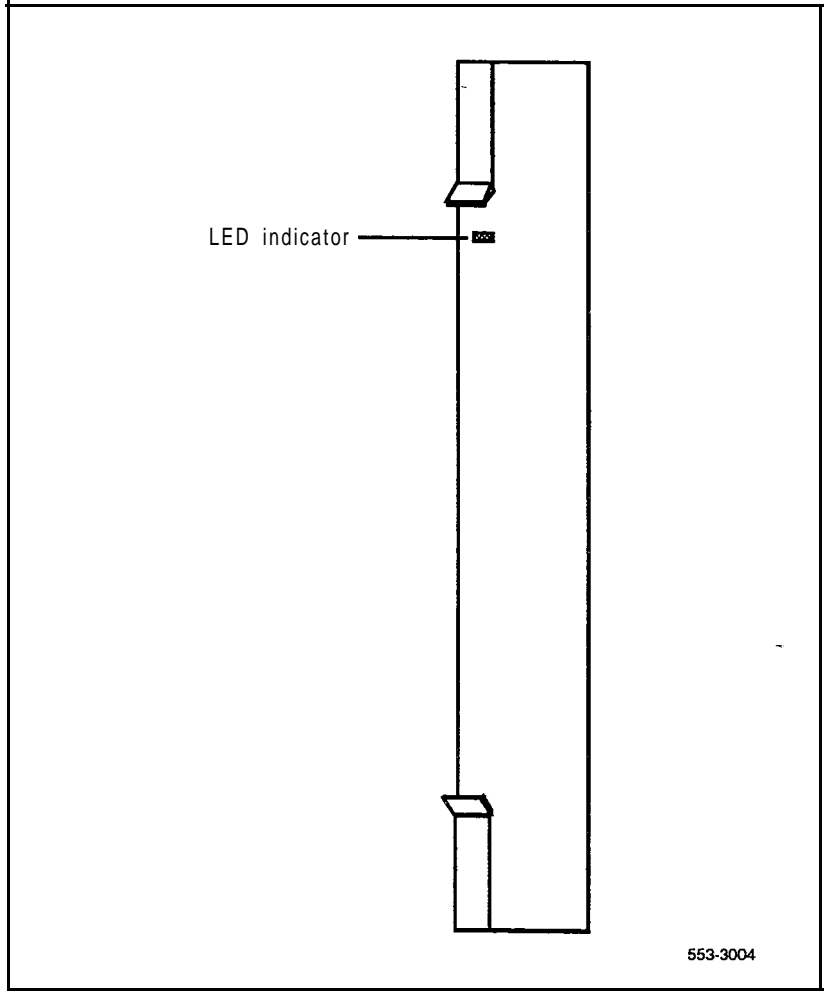

CPU controls

Switches and buttons on Common Equipment cards allow you to control CPU activity and clear Common Equipment faults.

Initialize button

In system options **51, 61**, and 71, the manual initialize (MAN INT) button is located on the **QPC580** CPU Interface Card. In system option 21, the manual initialize button is on the **NT8D19AA** Memory/Peripheral Signaling Card. Pressing the manual initialize button associated with the active CPU starts the initialize program.

The initialize program clears Common Equipment faults then rebuilds call-dependent data and generates system messages indicating the status of the system. This process is called an initialization (or *init*). Call processing is briefly interrupted during an initialization.

Normal/maintenance switch

There is a normal/maintenance (**NORM/MAINT**) switch on the QPC580 CPU Interface Card (used in system options **51, 61**, and 71). In system options **61** and 71 (dual CPU systems), you use this switch as follows to keep the dual CPUs from switching, or trying to switch, when you are testing or replacing Common Equipment hardware:

- On the CPU you are not testing or replacing, set the switch to MAINT. This CPU will be *active*.
- On the CPU you are testing or replacing, set the switch to NORM. This CPU will remain *inactive* as long as the other CPU is set to MAINT.

For regular operation in system options 61 and 71, set the switch on both CPU Interface Cards to NORM. For system option 5 1 (a single CPU system), set the normal/maintenance switch to MAINT.

Figure 6 shows the location of both the manual initialize button and the normal/maintenance switch on the CPU Interface Card.

Figure 6
Manual initialize button and normal/maintenance switch on the CPU
Interface Card

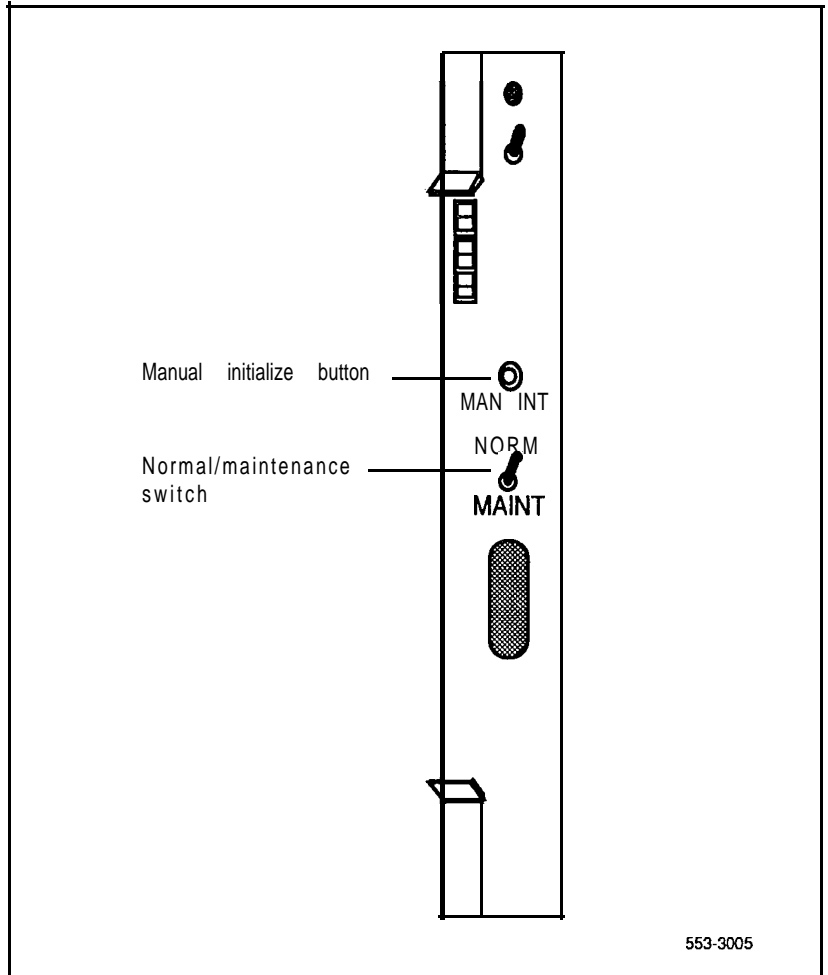

Reload button

Reload buttons allow you to manually activate the System Loader program. The System Loader initiates call processing and starts memory-checking diagnostics. This process is called a *sysload* (or *system* reload).

There is a reload (**RLD**) button on **the QPC58** 1 Changeover and Memory Arbitrator (CMA) Card used in system options **51, 61**, and 71. Figure 7 shows the location of the reload button on the CMA Card. In system option 5 1, pressing the reload button on **the** single CMA Card in the system starts a sysload. In system options 61 and 71 (dual CPU systems), you must simultaneously press the reload button on both CMA cards.

In system option 21, pressing the reload (reset) button on the QPC687 CPU Card starts the System Loader program.

CAUTION

Active calls are disconnected and the system goes into an emergency line transfer state during a sysload. Use the reload button only if you are specifically instructed to do so in Northern Telecom Publications.

Figure 7
Reload button on the Changeover and Memory Arbitrator Card

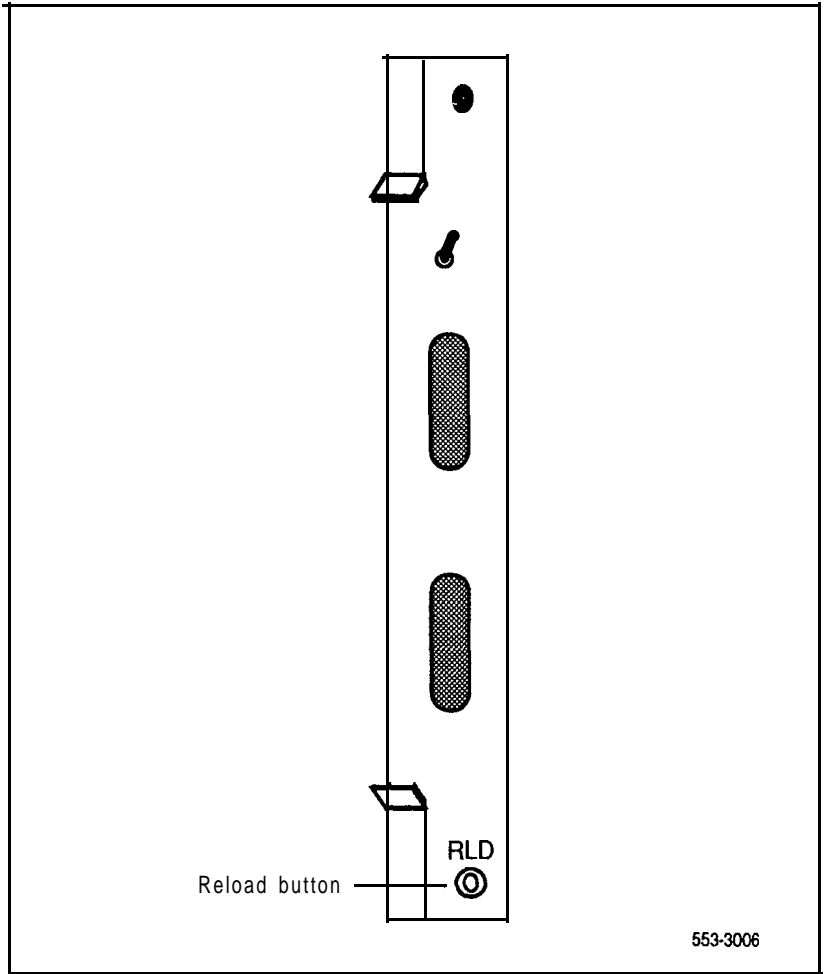

System alarms

System alarms are based on various fault monitors and indicators. The category of the alarm — major, minor, or remote — indicates the severity of the system failure:

- a major alarm requires immediate action by the technician
- a minor alarm requires attention, but not necessarily immediate attention, by the technician
- a remote alarm may require attention by the technician

Major alarms

A major alarm indicates a fault which seriously interferes with call processing. The causes of major alarms are listed in Table 5.

When a Power Fail Transfer Unit (PFTU) is attached to the SL-1, a major alarm causes designated 500- or 2500-type telephone sets to connect directly to Central Office trunks; this is called a line transfer.

Minor alarms

A minor alarm indicates the system hardware or software has detected a fault requiring attention. The causes of minor alarms are listed in Table 5.

A minor alarm displays an alarm on attendant consoles in customer groups affected by the fault. (A minor alarm indication on the console is an optional feature, enabled and disabled on a customer basis through data administration procedures.)

Remote alarms

A remote alarm, in the context of general maintenance, is an extension of a major alarm on the SL-1 to another location or a visual indicator. This means the SL-1 generates a signal indicating it has a major alarm condition and sends it to a remote location, such as a monitoring center or test center, or an indicator, such as a light or bell.

Table 5
Causes of major and minor alarms

Alarm Cause	
Major	<ul style="list-style-type: none">. CPU or control bus failure. Disk system failure when attempting to load the system. System power failure (without reserve power). Temperature fault (excessive heat)
Minor	<ul style="list-style-type: none">. Automatic Identification of Outward Dial (AIOD) trunk failure. Conference failure. Digitone Receiver failure. Memory failure. More than one fault on different line and trunk cards in one shelf (indicated on affected customer's console only). Network failure (indicated on affected customer's console only). Peripheral Signaling failure. Serial Data Interface (SDI) failure. Tone and Digit Switch (TDS) failure

System Monitor indicators

The System Monitor checks the column temperature, cooling system status, and system voltage status and controls line transfer states accordingly.

NT7D15AA System Monitor

System option 21A is equipped with the **NT7D15AA** System Monitor. This System Monitor performs the following functions:

- If the main circuit breaker in **the** system trips (for example, if there is a power surge or short circuit), the System Monitor starts a line **transfer** and sends a remote alarm signal.
- If the temperature of the column reaches 70 degrees C (158 degrees F), the System Monitor trips the main circuit breaker, starts a line **transfer**, and sends a remote alarm signal.
- If the UEM power supply loses **+5** volts, the System Monitor starts a line transfer and sends a remote alarm signal.
- If the UEM power supply loses any voltage other than **+5** volts, the System Monitor lights the column LED, sends a major alarm indication to the CPU, and sends a remote alarm signal.
- If call processing stops, the System Monitor lights the column LED and starts a line transfer.

Note: The **NT7D15AA** System Monitor does not generate system messages.

When major system failures occur, the System Monitor sends a remote alarm signal. As an option, an indicator, such as a bell or light, can be connected to the System Monitor to receive the remote alarm signal.

NT8D22AB System Monitor

System options 21 (other than option 21A), 51, 61, and 71 are equipped with the NT8D22AB System Monitor. Table 6 lists faults monitored by this System Monitor.

Table 6
Faults monitored by the NT8D22AB System Monitor

Power faults	Source
CPU condition	<ul style="list-style-type: none"> . CPU failure . Sysload (system reload)
Main power loss	<ul style="list-style-type: none"> . System input power, AC or DC
Power supply failure	<ul style="list-style-type: none"> . Common Equipment Power Supply . Common/Peripheral Equipment Power Supply . Peripheral Equipment Power Supply . Ringing Generator
Temperature alarm	<ul style="list-style-type: none"> . Fan Unit or Blower Unit • Column temperature sensors

In multiple-column systems, you can have one master System Monitor, located in the column with CPU-O, and multiple slave System Monitors.- A switch setting on each System Monitor defines the card as the master or as a slave.

The master System Monitor checks the CPU column and periodically polls the slaves to check their status. When polled, the slaves report their status to the master. If a slave does not respond when it is polled, the master reports the address as a faulty slave.

Note: If a slave is removed, the master cannot communicate with higher addresses. Therefore, the master considers the slave that was removed and all slaves with a higher address as disabled. For example, if slave 2 is disabled the master also reports slaves 3, 4, and up as disabled.

The System Monitor reports power equipment status and faults to the CPU. (In multiple-column systems, only the master System Monitor communicates with the CPU.) System messages generated by the System Monitor are identified by the mnemonic PWR. Figure 8 shows the flow of messages from NT8D22AB System Monitors to the system terminal.

If there is a fault, the System Monitor lights the LED on the affected column.

Figure 8
NT8D22AB System Monitor message flow

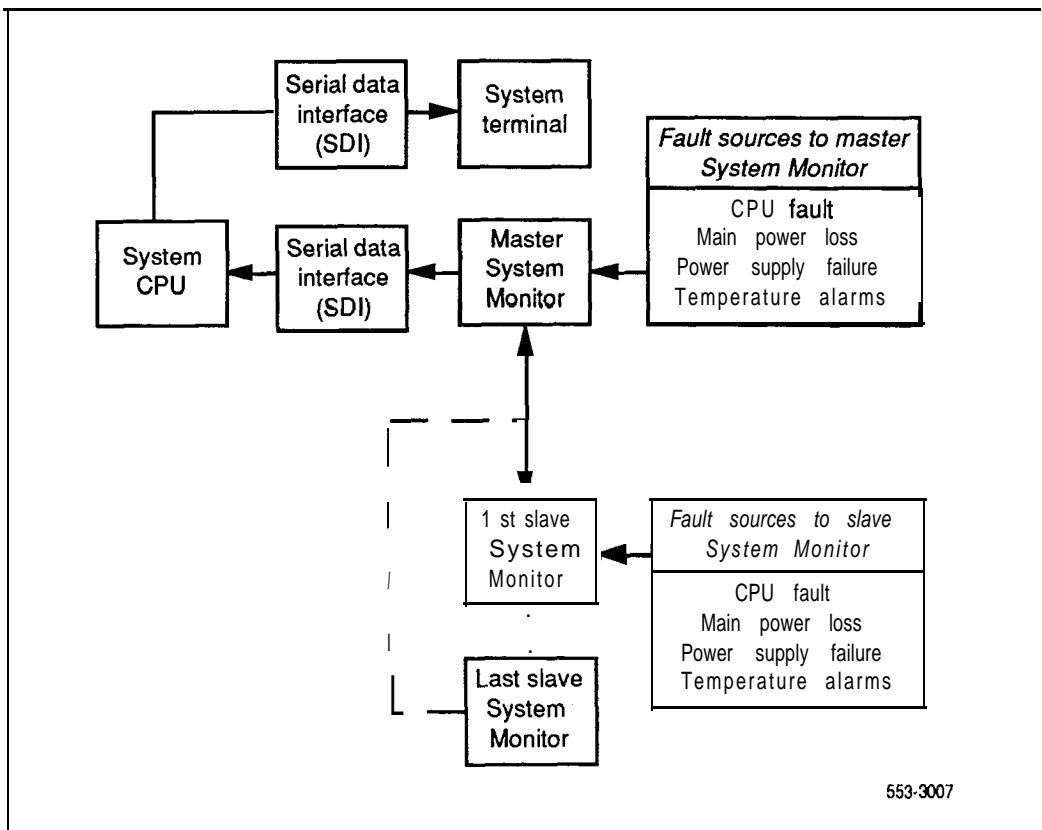

Line transfer

As an option, you can connect one or more Power Fail Transfer Units (PFTUs) to the SL-1. Each PFTU connects up to eight designated 500- or 2500-type telephone sets to Central Office trunks. If call processing stops, those 500/2500-type telephone sets are transferred through the PFTU to the Central Office so you still have outside connections. A line transfer occurs:

- during a sysload (system reload)
- if there is a major power failure in a DC-powered system (as detected by the TRIP signal)
- if call processing stops due to a CPU failure
- if there is a loss of power to the column
- if there is a loss of power to the PFTU
- if there is an over-temperature condition in a column
- when the line transfer button on the attendant console is pressed (this applies on a customer basis)
- when the line transfer switch on the PFTU is turned on

Note: When the PFT switch (SWI-4) is set to ON on a System Monitor, that System Monitor's column will not activate a line transfer.

Figure 9 shows four ways multi-column systems and PFTUs can be configured. You can:

- connect all the columns in a system to a single PFTU
- connect each column to an individual PFTU
- combine connecting individual columns to individual PFTUs and multiple columns to a single PFTU
- attach additional PFTUs to a PFTU that is connected to one or multiple columns

Figure 9
PFTU configurations

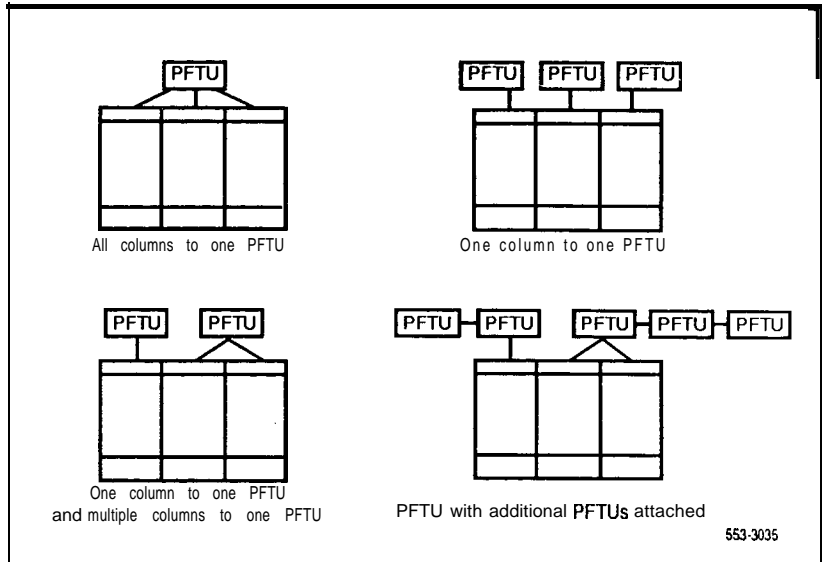

Main power loss

The System Monitor receives status and control signals from the external power distribution. The System Monitor then generates system messages that indicate the status of main and reserve power supplies.

You can connect a reserve (back-up) power supply to the SL- 1: an Uninterruptible Power Supply (UPS) for AC-powered systems or reserve batteries for DC-powered systems. If the main source of external power is lost, power to the system is maintained by the UPS or reserve batteries.

If the main power supply is lost, the System Monitor generates a major alarm and system messages to indicate the system is running on reserve power.

UEM power supply failure

There **are** four types of UEM power supplies:

- Common Equipment Power Supply
- Common/Peripheral Equipment Power-Supply
- Peripheral Equipment Power Supply
- Ringing Generator (Message Waiting)

Complete or partial failures in a UEM power supply are handled as follows:

- If output voltage is higher than the threshold for **+5** volts, the effected power supply shuts down, the column LED lights, and a system message is sent.
- If output voltage is higher than the threshold for other than **+5** volts, power for only that voltage shuts down in the effected power supply, the column LED lights, and a system message is sent.
- If output voltage is lower than the threshold for any voltage, power for only that voltage shuts down in the effected power supply, the column LED lights, and a system message is sent.
- If input voltage is lower than the threshold, the effected power supply shuts down then recovers when the input level recovers.

To help you pinpoint a power supply problem, a master **NT8D22AB** System Monitor identifies:

- the column with the fault (System Monitor O-63)
- the UEM (O-3) in that column
- the power supply unit (I-2) in the UEM

Figure 10 shows the power equipment designations in a column.

Figure 10
Power equipment designations

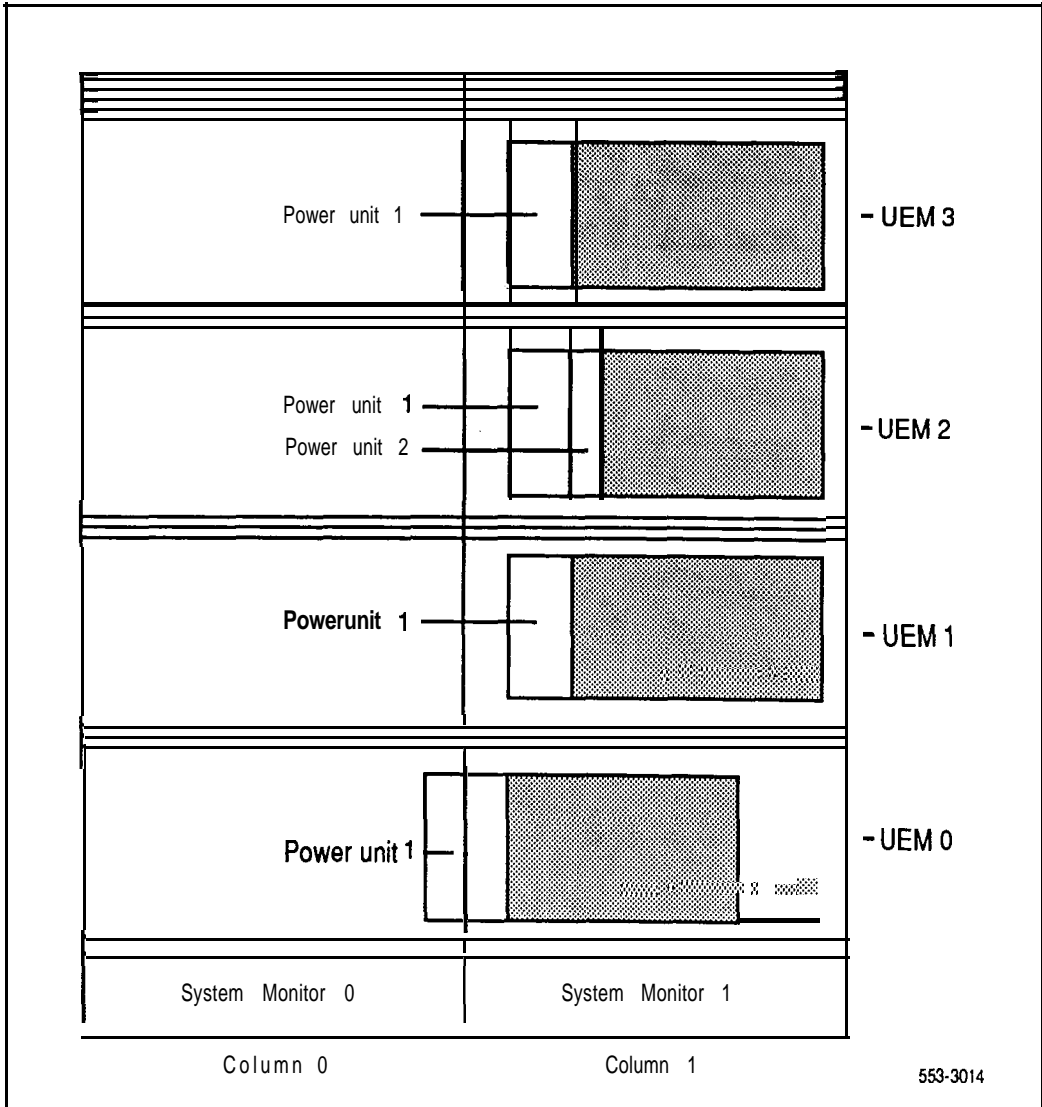

Temperature alarms

System option 21A has two fans in the top cap. If the temperature of the system exceeds 70 degrees C (158 degrees F), the **NT7D15AA** System Monitor trips the main circuit breaker to prevent further overheating.

Each column in system option 21 (other than 21A) is cooled by a Fan Unit (**NT7D17AC** or **NT7D17DC**) or Blower Unit (**NT8D52AA** or **NT8D52DC**) in the pedestal. There is a Blower Unit in each pedestal in system options **51, 61, and 71**. All of these systems are equipped with the **NT8D22AB** System Monitor, which performs the following functions:

- If there is a partial or complete failure in a Fan or Blower Unit, the System Monitor lights the column LED and generates a system message.
- If the thermostats in a column report a temperature exceeding 70 degrees C (158 degrees F), the System Monitor lights the column LED, generates a system message, then shuts down power to the column in 30 seconds, providing this condition exists for 30 seconds.

In systems with a Blower Unit, the System Monitor generates a system message if the air leaving the column exceeds 55 degrees C (131 degrees F). This thermal alarm may indicate a loss of air-conditioning in the room, loss of ventilation in the column, a problem with the Blower Unit, or a blocked air filter. This alarm is not reported in systems with a Fan Unit.



Software maintenance tools

Chapter contents

Introduction	37
Diagnostic programs	38
Error Monitor	38
Initialize Program	39
Midnight and Background Routines	39
Overlay Loader	41
Overload Monitor	41
Resident Trunk Diagnostic	41
System Loader	42
History File	- 43
Interactive diagnostics	44
Enhanced Maintenance	44
Manual Continuity Tests	45

Introduction

SL-1 software maintenance tools help you identify and clear faults, as well as providing self-checking capabilities. Software maintenance tools are divided into the following categories:

- Diagnostic routines: monitor a variety of operations, detect faults, and initiate corrective action during normal call processing.
- History File: records maintenance-related system messages.
- Interactive programs: test hardware, isolate faults, and verify fault clearing.

Diagnostic programs

Diagnostic software programs monitor system operations, detect faults, and clear faults. Some programs run continuously, some are scheduled.

Diagnostic programs **are resident** or **non-resident software** programs. Resident programs, such as the Error Monitor and Resident Trunk Diagnostic, are always present in system memory. Non-resident programs, such as the Input/Output Diagnostic and Common Equipment Diagnostic, are used as Midnight and Background Routines or for interactive diagnostics. Non-resident programs are loaded from the system disk and run as scheduled or upon request.

Note: Non-resident programs are also called overlays or loads. They are identified by a title and a number preceded by the mnemonic for load (for example, Trunk Diagnostic — LD 36).

See **the XII input/output guide** (553-3001-400) for detailed information on all diagnostic programs.

Error Monitor

The Error Monitor is a resident program which continuously tracks call processing. The Error Monitor generates system messages if it detects invalid or incorrectly formatted call processing information.

System messages generated by the Error Monitor are preceded by the mnemonic ERR, which usually indicates hardware faults, or the mnemonic BUG, which usually indicates software problems.

With prompt ERRM in the Configuration Record (LD 17), you can instruct the system to print or not print ERR or BUG messages. You should have BUG messages print. If many similar BUG messages occur, consult your Technical Assistance Center.

Initialize Program

The Initialize Program momentarily interrupts call processing as it clears Common Equipment faults. It then rebuilds call-dependent data and generates system messages, with the mnemonic **INI**, which indicate the status of the system. This process is called -an **initialization** (or **init**).

You can download firmware from the CPU to Superloop Network Cards and Controller Cards through an initialization. Call processing is interrupted for an additional amount of time during **this** process.

You can activate an initialization by pressing the manual initialize (MAN INT) button. An initialization occurs automatically:

- after the System Loader program runs
- when a software or firmware fault is detected
- when a Common Equipment hardware fault is detected

Midnight and Background Routines

In the Configuration Record (**LD 17**), you can assign sets of non-resident software programs as a **Midnight Routine** and a **Background Routine**. **These** routines automatically perform maintenance checks. Programs included in the Midnight Routine are defined with the prompt DROL (derived from "daily routine overlay"). Programs included in the Background Routine are defined **with** the prompt BKGD.

The Midnight Routine runs once every 24 hours. This routine is preset to run at midnight when an SL-1 is shipped, but you may assign a different time in the Configuration Record. When it is time for the Midnight Routine to start, **the** system cancels any other program.

The Background Routine runs when no other program is loaded in the overlay area. The programs included in the Background Routine run in sequence repeatedly until there is another request to use the overlay area (for example, if you log on to check the status of a circuit card) or the Midnight Routine runs.

You may include the programs listed in Table 7 in 'Midnight and Background Routines. Software Audit (**LD 44**), Background Signaling and Switching Diagnostic (**LD 45**), and Network and Signaling Diagnostic (LD 30) should always be **used** in the Background Routine. Your **needs** and the configuration of your system will determine the other programs you **include** in Midnight and Background Routines.

Table 7

Programs used in Midnight and Background Routines

Program number	Program function
LD 30	Network and Signaling Diagnostic
LD 32 (Midnight only)	Network and Peripheral Equipment Replacement
LD 33	1.5 Mb/s Remote Peripheral Equipment Diagnostic
LD 34	Tone and Digit Switch and Digitone Receiver
LD 35	Common Equipment Diagnostic
LD 36	Trunk Diagnostic 1
LD 37	Input/Output Diagnostic
LD 38	Conference Circuit Diagnostic
LD 40	Call Detail Recording Diagnostic
LD 41	Trunk Diagnostic 2
LD 43 (Midnight only)	Data Dump
LD 44	Software Audit
LD 45	Background Signal and Switching Diagnostic
LD 46	MF Sender Diagnostic for ANI
LD 60 (Midnight only)	Digital Trunk Interface Diagnostic
LD 61 (Midnight only)	Message Waiting Lamp

Overlay Loader

This resident program locates, loads, and checks all non-resident software programs. It automatically activates the Midnight and Background Routines. You can load programs manually by entering commands through the system terminal or maintenance telephone. Once the program is loaded, you see the program mnemonic (such as TRK for Trunk Diagnostic) on the system terminal.

You can also use the Overlay Loader to enable, disable, and display the status of the disk drive unit.

Overload Monitor

The volume of system messages is continuously monitored by the system. If too many error messages are detected from a line or trunk card, the system activates the Overload Monitor program. The Overload Monitor disables the faulty card and generates system messages with the mnemonic OVD.

Resident Trunk Diagnostic

This program automatically monitors all trunk calls and records apparent faults on each trunk. If the number of faults on a trunk exceeds the threshold for that trunk, the program generates a system message identifying the trunk and the type of fault.

A failure on a trunk may keep the trunk from detecting incoming calls. The threshold mechanism cannot detect such a failure, so this program also records how many days it has been since each trunk received an incoming call. If you suspect some incoming calls are not being processed, you can use the command LMAX in Trunk Diagnostic 1 (LD 36) to identify the trunk with the maximum idle days.

System Loader

The System Loader loads all call processing programs and data, and starts memory-checking diagnostics. After all required programs and data have been loaded and all checks performed, the System Loader program is erased from system memory, the Initialize Program runs, and normal call processing begins. This process is called a **sysload** (or **system reload**).

The System Loader operates automatically on system power up or if a Common Equipment or power fault destroys information in the system memory.

You can start a sysload manually by pressing the reload or reset button in single CPU systems, or by simultaneously pressing both reload buttons in a dual CPU system. For maintenance purposes, you generally activate this program only if call processing has stopped.

Note: The system loses the time and date during a sysload. You should reset the time and date using LD 02.

CAUTION

Active calls are disconnected and the system goes into an emergency line transfer state during a sysload. Activate the System Loader only if you are specifically instructed to do so in Northern Telecom Publications.

History File

If you have a printer connected to the SL- 1, each system message is printed as it is received. If you do not have a printer connected, you can use the History File (if equipped) to store a limited number of system messages in protected memory. The contents of the file may then be printed on demand, using **Print Routine 3 (LD 22)**.

The messages stored are specified on a system basis and can be one or more of the following types:

- customer service changes (CSC)
- maintenance messages
- service changes (SCH)
- software errors
- initialization and sysload messages
- traffic messages

For information on selecting the messages to be stored, see ***X11 features and services (553-3001-305)***.

The contents of the History File are erased during a sysload (system reload) or if you change the length of the History File. However, because the History File is located in protected data store, the contents survive an initialization (**init**).

You can change the length of the History File with the prompt HIST in the Configuration Record (**LD 17**). The maximum length of the file depends on the amount of protected data store available, which in turn depends on the number of system features that require protected data store.

If **the** History File is full, **the** first messages stored are replaced by incoming messages. If this happens, the system gives a “file overflow” message at the start of a printout so you know some information has been replaced by newer messages.

Interactive diagnostics

You can load non-resident software programs into memory through the system terminal or maintenance telephone. These programs, also called overlays or loads, are identified by a title and a number which is preceded by the mnemonic for load (for example, Trunk **Diagnostic** — LD 36).

Note: The programs used in Midnight and Background **Routines** are also used manually as interactive diagnostic programs (see Table 7).

Non-resident programs are used interactively with a **command/response** format. In this format, you enter a command that tells the system to perform a specific task; the system performs the task and sends **system** messages indicating status or errors back to you.

With interactive diagnostics you can:

- disable, test, and enable specific equipment
- verify that a reported fault still needs to be cleared
- verify that a repair procedure has cleared a fault

All maintenance programs, commands, and system messages are described in detail in the **X11 input/output** guide (553-3001-400).

Enhanced Maintenance

System software sometimes requires modifications, called **patches**, provided by Northern Telecom Technical Assistance Centers. The command ISS in Print Routine 3 (**LD 22**) prints the software generic and issue. A plus sign (+) by the issue number means there is a patch in service.

The Enhanced Maintenance feature:

- allows patches to automatically survive a sysload
- permits patches on non-resident programs
- records **all** patches in the system
- allows data disks to be shipped with pre-loaded patches

If there is a problem with a patch, the CPU sends system messages, with the mnemonic EHM, to the system terminal or the History File.

Manual Continuity Tests

You can perform Manual Continuity Tests on Superloop Network Cards and Intelligent Peripheral Equipment. A continuity test generates a signaling pattern at one point, monitors its progress, and checks for its detection at an end point. For example, when a Super-loop Network Card sends a signal to a Controller Card, the continuity test verifies:

- the Superloop Network Card sent the signal
- the loop carried the signal to the Controller Card
- the Controller Card received the signal

In a point-to-point continuity test, a Superloop Network Card or a Controller Card can generate or detect the test pattern. In **loopback** tests, one card is both the generator and the detector. Only idle timeslots are tested.

Fifteen continuity tests can run simultaneously. When a test is completed, that test stops, the status is reported, and the other tests continue running. You can check the status of any test at any time. When all the tests end, the number of tests run and any failed tests are reported to the CPU. You can display the results at any time.

There are eight continuity test configurations. You can run each test by entering a set of prompts outlined in the Background Signaling and Switching Diagnostic (**LD 45**). Figure 11 shows point-to-point configurations; Figure 12 shows **loopback** configurations.

Figure 11
Manual Continuity Tests: Point-to-point configurations

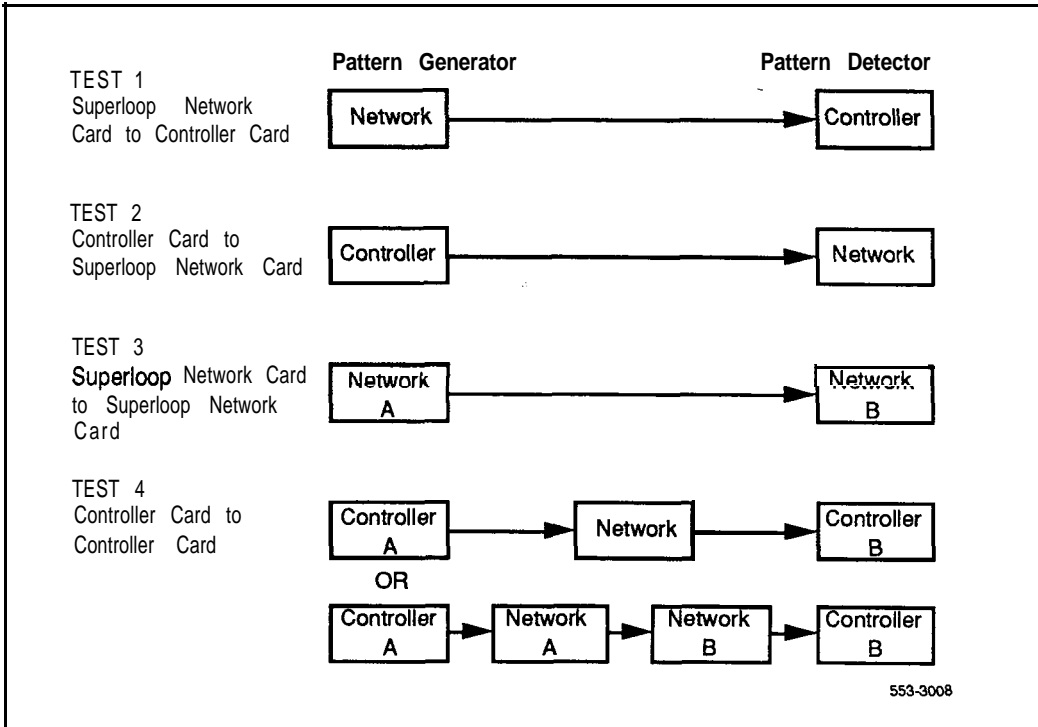
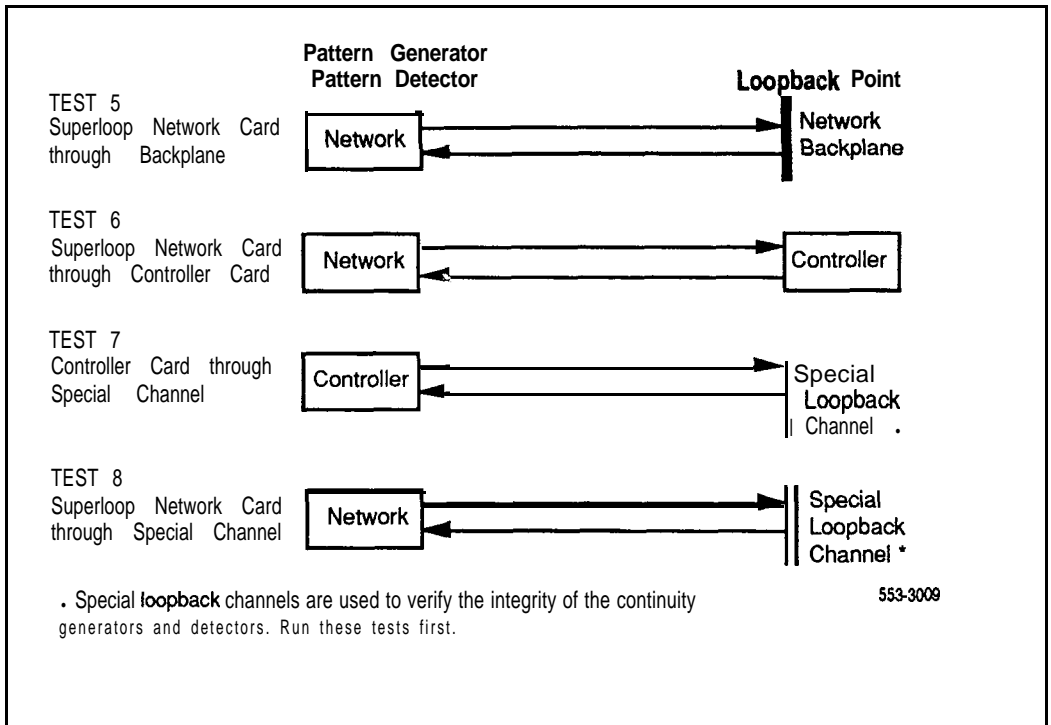

Figure 12
Manual Continuity Tests: Loopback configurations





User reports

Reports from system users often tell you about problems that may not be indicated by the system. Many faults reported by users, such as a damaged telephone or data set, are obvious and can be fixed by replacing the damaged equipment.

Some faults are less obvious and may be caused by other equipment, such as a defective Peripheral Equipment line or trunk card. To classify the fault in these cases, check for system messages and visual fault indications. You may also need to have the user reproduce the problem so you can determine the sequence of events that led to the fault.

Table 8 lists problems that are typically reported by users.

Table 8
User report indications

User report	Type of fault
<ul style="list-style-type: none"> • Major alarm reported by attendant • No ring on 500/2500-type telephone sets 	Power ~
<ul style="list-style-type: none"> • Major alarm reported by attendant 	Common Equipment
<ul style="list-style-type: none"> • Minor alarm reported by attendant 	Network Equipment
<ul style="list-style-type: none"> • Users cannot transfer or conference • Users cannot dial out on 500/2500- type telephone sets 	
<ul style="list-style-type: none"> • Trouble with calls on attendant console 	Peripheral Equipment
<ul style="list-style-type: none"> • Trouble with calls on 500/2500-type telephone sets 	
<ul style="list-style-type: none"> • Trouble with calls on SL-1, MI 000, or digital telephone sets 	
<ul style="list-style-type: none"> • Users have trouble with a specific trunk 	Trunk
<ul style="list-style-type: none"> • Callers report continuous ringing 	
<ul style="list-style-type: none"> • Trouble with calls on console and/or telephone sets 	
<ul style="list-style-type: none"> • Trouble with calls 	Attendant console
<ul style="list-style-type: none"> • Trouble with equipment (such as handset, headset, or display) 	
<ul style="list-style-type: none"> • Trouble with calls 	Telephone set
<ul style="list-style-type: none"> • Trouble with equipment (such as handset or add-on module) 	

Customer technical assistance service

Chapter contents

Introduction	51
Services available	53
Requesting assistance	56

Introduction

To help customers obtain maximum benefit, reliability, and satisfaction from their SL-I, Northern Telecom provides technical assistance in resolving system problems. This service is provided through the centers listed in Table 9.

Table 9
Northern Telecom Technical Assistance Centers

Location	Contact
Northern Telecom Inc. (ETAS) 2100 Lakeside Blvd. Richardson, Texas, USA 75082	Tel: 214-437-8282 Fax: 214-437-8913
Northern Telecom Canada Ltd. (CTAS) P.O. Box 4000 250 Sydney Street Belleville , Ontario, Canada K8N 5B7	Tel: 613-966-8181 Fax: 613-966-0100 x3720
Northern Telecom Corp. (CALA) 14701 NW 77th Avenue Miami, Florida, USA 33014	Tel: 305-526-8400 Fax: 305-526-8580
Northern Telecom House (EUR) Saint Cloud Way Maidenhead, Berks, England SL6 8XB	Tel: 753-81-3000 Fax: 628-21787
Northern Telecom Ltd. (ASIA) 2 Leng Kee Road #03-01 Thye Hong Centre Singapore, Singapore 0315	Tel: 65-474-2255 Fax: 65-4700-888
Nortel Property Ltd. (Australia) 17 Orion Road Lane Cove New South Wales, Australia 2066	Tel: 2 428-8777 Fax: 2 428-8765

—continued—

Table 9
Northern Telecom Technical Assistance Centers (continued)

Location	Contact
Northern Telecom Japan Inc. Headquarters Oak Minami-Azabu Building 19-23 Minami-Azabu 3 Chome-Minato-ku Tokyo, Japan 106	Tel: 3441-1811 Fax: 3 441-2380
Northern Telecom Meridian S.A. (France) Tour Gan 16 Place de l'Iris-Cedex 13 92082 Paris la Defense France	Tel: 149072424 Fax: 1 49 01 01 89

Services available

Services available through the Technical Assistance Centers include:

- diagnosing and resolving software problems not covered by support documentation
- diagnosing and resolving hardware problems not covered by support documentation
- assisting in diagnosing and resolving problems caused by local conditions

There **are** several types of class-of-service available. Emergency requests (Class E1 and E2) receive an immediate response. Service for emergency requests is continuous until normal system operation is restored. Non-emergency requests (Class S 1, S2, and NS) are serviced during normal working hours. Service classifications are described further in Tables 10 and 11.

Except as excluded by the provisions of warranty or other agreements with Northern Telecom, a fee for technical assistance may be charged, provided at rates established by Northern Telecom. Information on rates and conditions for services are available through Northern Telecom sales representatives.

Table 10
Technical service emergency classifications

Class	Degree of failure	Symptoms
E1	Major failure causing system degradation or outage	<ul style="list-style-type: none"> . System out of service with complete, loss of call-processing capability . Loss of total attendant console capability . Loss of incoming or outgoing call capability . Loss of auxiliary CDR in resale application . Call processing degraded for reasons such as <ul style="list-style-type: none"> — trunk group out of service — 10% or more lines out of service — frequent initializations (seven per day or more) — inability to recover from initialization or sysload — consistently slow dial tone (eight seconds or more delay)
E2	Major failure causing potential system degradation or outage	<ul style="list-style-type: none"> . Standby CPU out of service . Frequent initializations (one per day or more) . Disk drive failure . Two sets of disks inoperative

Table 11
Technical service non-emergency classifications

Class	Degree of failure	Symptoms
S1	Failure which affects service	<ul style="list-style-type: none"> . Software or hardware trouble directly and continuously affecting user's service or customer's ability to collect revenue . Problem that will seriously affect service at in-service or cut-over date
s2	Intermittent failure which affects service	<ul style="list-style-type: none"> . Software or hardware faults that only intermittently affect service . System related documentation errors which directly result in or lead to impaired service
NS	Failure which does not affect service	<ul style="list-style-type: none"> . Documentation errors . Software inconsistencies which do not affect service . Hardware diagnostic failures (not defined above) which cannot be corrected by resident skills . Test equipment failures for which a back-up or manual alternative can be used . Any questions concerning SL-1 products

Requesting assistance

Collect the information listed in Table 12 before you call for service.

Table 12
Checklist for service requests

Request for technical assistance	
Name of person requesting service	_____
Company represented	_____
Telephone number	_____
SL-1 system option number/identification	_____
Installed software generic and issue (located on data disk)	_____
Modem telephone number and password (if applicable)	_____
Seriousness of request (see Tables 10 and 11)	_____
Description of assistance required	_____

-



2



SL-1

System options 21, 51, 61, 71

General maintenance information

Copyright © 1990 Northern Telecom

All rights reserved.

Information subject to change without notice

Release 2.0

Standard

February 28, 1990

Printed in U.S.A.



553-3001-510

SL-1

System options 21; 51, 61, 71

Fault clearing
Standard

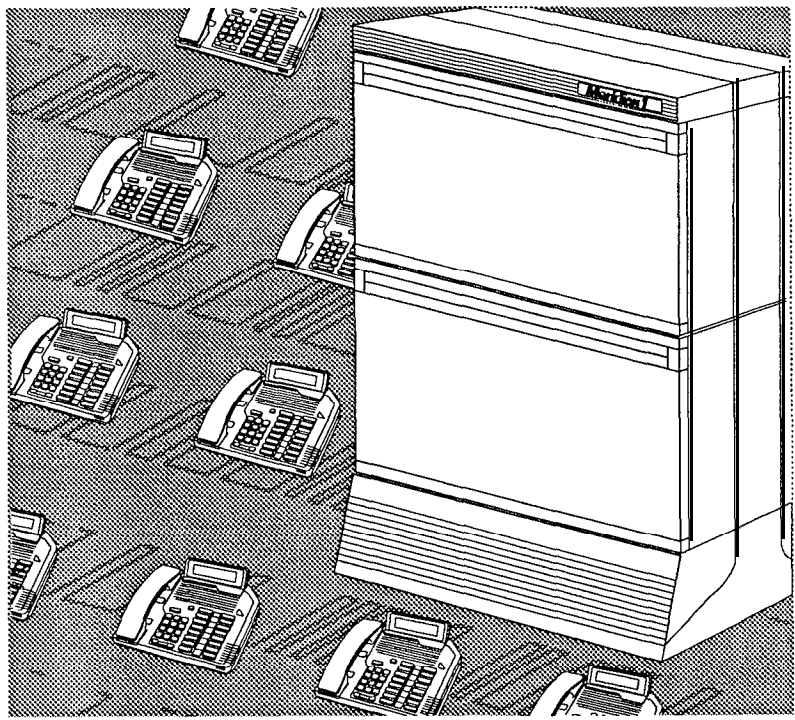

nt northern
telecom

Meridian 1
Communication Systems





SL-1

System options 21, 51, 61, 71

Fault clearing

Publication number: 553-3001-510

Document release: 2.0

Document status: Standard

Date: February 28, 1990



© 1990 Northern Telecom

All rights reserved

Fault clearing 553-3001-510

Revision history

January 29, 1990

Standard, release 1.0

February 28, 1990

Standard, release 2.0

Contents

About this document	1
References	2
<hr/>	
How to clear faults	3
Chapter contents	3
Fault clearing process	3
Using this document	4
<hr/>	
Fault indicators	7
Chapter contents	7
introduction	7
System messages	7
Visual fault indicators	9
Maintenance display codes	10
User reports	11
<hr/>	
Accessing the system	13
Chapter contents	13
Introduction	13
Access through the system terminal	14
Access through the maintenance telephone	16

Clearing power faults	19
Chapter contents	19
Power faults	20
Fault clearing procedures	24
Symptoms:	
Main circuit breaker and all LEDs off (system option 21A)	27
Main circuit breaker on but all LEDs off (system option 21 A)	28
Green LED off on UEM power supply (system option 21A)	30
Circuit breakers and all column LEDs off (DC power)	31
Circuit breakers on but all column LEDs off (DC power)	33
Green LED off on UEM power supply (DC power)	34
Defective Blower or Fan Unit indicated (DC power)	36
Main circuit breaker and all column LEDs off (AC power)	37
Main circuit breaker on but all column LEDs off (AC power)	39
Breaker off on Module Power Distribution Unit (AC power)	41
Green LED off on UEM power supply (AC power)	43
Defective Blower or Fan Unit indicated (AC power)	45
Clearing Common Equipment faults	47
Chapter contents	47
Common Equipment faults	48
Fault clearing procedures	48
Symptoms:	
Call processing stopped (system option 21)	49
Fault indicated on Memory/Peripheral Signaling Card (system option 21)	52
Fault indicated on the CPU card (system option 21)	53
Call processing stopped (system option 51)	55
Fault indicated on Memory Card (system option 51)	58
Fault indicated on a Common Equipment card (system option 51)	60
Call processing stopped (system options 61 and 71)	62
Fault indicated on a Memory Card (system options 61 and 71)	65
Fault indicated on a Common Equipment card (system options 61 and 71)	68
Floppy Disk Unit not operating	71
Multi Disk Unit not operating	72

Clearing Network Equipment faults	75
Chapter contents	75
Network Equipment faults	75
Fault clearing procedures	76
Symptoms:	
Disabled loop indicated by OVD message (NT8D04AA Superloop Network Card)	78
Loop disabled without OVD message (NT8D04AA Superloop Network Card)	80
Disabled loop indicated by OVD message (QPC414 Network Card)	83
Loop disabled without OVD message (QPC414 Network Card)	86
Disabled Peripheral Signaling Card indicated by OVD message	89
Peripheral Signaling Card disabled without OVD message	91
Problems with transferring, placing conference calls, or Music-on-Hold	93
Problems placing calls on 2500-type telephone sets and some trunks	95

Clearing Peripheral Equipment faults	97
Chapter contents	97
Peripheral Equipment faults	98
Fault clearing procedures	98
Symptoms:	
Red LED lit on Controller Card	100
Red LED lit on Dual Loop Peripheral Buffer Card	102
Disabled Peripheral Equipment card	104
More than one Peripheral Equipment card disabled	106

Clearing trunk faults	109
Chapter contents	109
Trunk faults	110
Fault clearing procedures	110
Symptoms:	
Trunk cannot make or receive calls (OVD message received)	112
Trunk cannot make or receive calls (no OVD message)	115

Clearing attendant 'console faults	119
Chapter contents	119
Attendant console faults	120
Fault clearing procedures	121
Symptoms:	
Console cannot make or receive calls (OVD message received)	122
Console cannot make or receive calls (no OVD message)	124
Indicator or digit display not functioning properly	126
Operator cannot hear or be heard properly	128

Clearing telephone set faults	131
Chapter contents	131
Telephone set faults	131
Fault clearing procedures	132
Symptoms:	
Telephone set cannot make or receive calls (OVD message received)	134
Telephone set cannot make or receive calls (no OVD message)	136
One end cannot hear or cannot be heard	138
Noise or low volume on all calls	140
Defective indicator, digit display, or component	142
Defective feature	144
Defective add-on module	145
Cannot dial from 2500-type telephone set	146
No ring on 500- and 2500-type telephone sets	148

Final maintenance procedure	151
Chapter contents	151
Introduction	151

About this document

This document gives instructions for locating and clearing faults in SL-I system options **21, 51, 61**, and 71. The procedures in this document are based on the assumption that the SL- 1 is properly installed (for example, all card locations, option switch settings, and cable connections are correct) and was fully operational before the fault.

To use this document, you should have a basic knowledge of SL-1 operation and maintenance. (Contact Northern Telecom Training Centers for information on courses.) You should also read and fully understand *General maintenance information* (553-3001-500) before attempting to clear faults.

This document does not provide procedures for replacing equipment. See *Hardware replacement* (553-3001-520) to replace faulty equipment.

References

See the *SL-1 planning and engineering guide* for

- ***Master index*** (553-3001-000)
- ***System overview*** (553-3001-100)
- ***Sparesplanning*** (553-3001-153)
- ***Equipment identification and ordering*** (553-3001-154)

See the list of line and trunk circuit descriptions in the ***Master index*** (553-3001-000) for specific references to lines and trunks.

See the *SL-I installation and maintenance guide* for

- ***System installation procedures*** (553-3001-210)
- ***Circuit pack installation and testing*** (553-3001-211)
- ***Installation procedures for telephone sets and attendant consoles*** (553-3001-215)
- ***General maintenance information*** (553-3001-500)
- ***Hardware replacement*** (553-3001-520)

See the *SL-I XII software guide* for an overview of software architecture, procedures for software installation and management, and a detailed description of all XI 1 features and services. This information is contained in two documents:

- ***X11 software management*** (553-3001-300)
- ***X11 features and services*** (553-3001-305)

See the *SL-1 XII input/output guide* (553-3001-400) for a description of all administration programs, maintenance programs, and system messages.

How to clear faults

Chapter contents

Fault clearing process	3
Using this document	4

Fault clearing process

When a fault must be cleared in the SL- 1, follow these steps:

- Observe and record all fault indicators.

System messages, visual fault indicators, maintenance display codes, and user reports identify many problems. If the indicators are not current or seem incomplete, you may need to print the History File for previous messages, you may need to initialize **the** system for information on the current status, or you may need to do both.

- Look up all system messages and maintenance display codes in the *X11 input/output guide* (553-3001-400).

The interpretation of the message or code may identify faulty equipment and tell you what action to take to clear **the** problem. If you cannot clear the fault through information in **the X11 input/output guide**, follow the process in this document to isolate and clear the fault (see “Using **this** document”).

- Try to enable or test disabled equipment.

You may be able to hardware reenable circuit cards by unseating **then** reinstalling them. You may be able to software reenable cards by disabling **then** reenabling them. When **the** cause of a fault is not clearly evident, a software test may help you identify the problem.

- Replace equipment as necessary.

When you identify faulty equipment, follow procedures in **Hardware replacement** (553-3001-520). When you think **the** fault is corrected, follow the instructions in “Final maintenance procedure” (**the** last chapter in this document) to completely restore normal operation.

Using this document

To use the information in this document, follow the steps below:

- 1 Classify the fault by the indicators present (see the next chapter, “Fault indicators”). When there are indications of multiple faults, clear them in the following order:

- Power faults
- Common Equipment faults
- Network Equipment faults
- Peripheral Equipment faults
- Trunk faults
- Attendant console faults
- Telephone set faults

Note: Always clear possible power faults then Common Equipment faults before any other type of fault.

- 2 Go to the chapter for clearing the type of fault identified. There is a chapter for each type of fault listed above (for example, “Clearing power faults”). As closely as possible, match the problem to a symptom in “Chapter contents.”
- 3 Go through the procedure for clearing each possible cause of the problem until the fault is cleared
- 4 When the fault is corrected, follow the instructions in “Final maintenance procedure” to completely restore normal operation.

Procedure 1 is an example of the process described above.

Procedure 1
An example of using this document

- 1 Classify the fault — The indicators present are listed in Table 1. They identify a Common Equipment fault.

Table 1
Using fault indicators to classify a fault

Fault indicators	Type of fault
SYSTEM MESSAGE: message CED013	Common Equipment
VISUAL FAULT INDICATOR: Red LED lit on Memory Card	Common Equipment
MAINTENANCE DISPLAY CODE: Code indicating a fault displayed on CPU interface Card	Common Equipment
USER REPORT: Major alarm reported by attendant	Common Equipment

- 2 Go to the chapter for clearing the fault and match the symptom- Go to “Clearing Common Equipment faults” and you will find “Fault indicated on Memory **Card**” in the table of contents.
- 3 Go through the procedures — Check for a defective Memory Card. If it is not defective, check for a defective Common Equipment card. If you **find** the CPU Interface Card was defective, you can disregard the remaining possible causes.
- 4 Go to “Final maintenance procedure” — Follow the instructions in each step.

Fault indicators

Chapter contents

Introduction	7
System messages	7
Visual fault indicators	9
Maintenance display codes	10
User reports	11

Introduction

When there is a fault in the system, you may be notified by any combination of the following indicators:

- system messages
- visual fault indicators
- maintenance display codes
- user reports

Each type of indicator is described below.

System messages

System messages are codes with a mnemonic and number, such as PWRO014. The mnemonic identifies a software program or a type of message. The number identifies the specific message. Use system messages with other indicators, such as maintenance display codes and visual indicators, to identify and clear faults.

Table 2 lists the most common fault indicating messages and the type of fault they indicate. For a complete list and interpretation of system messages, *see the XII input/output guide (553-3001-400)*.

Table 2
System message fault indicators and related fault types

System messages	Type of fault
<ul style="list-style-type: none"> . BSD090 . PWR messages 	Power
<ul style="list-style-type: none"> • BSD080, 085, 086, 103 . CED messages . INI001, 002, 004, 005, 007 . IOD006, 007, 060, 061, 291—297 . NWS030, 102, 103, 142 . SYS messages 	Common Equipment
<ul style="list-style-type: none"> • BSD081, 101, 110, 111, 121, 130, 201—203, 205—209, 600, 602 . CNF messages . DTA, DTC, DTI messages . ERR020, 120, 4060 . INI003, 008—012 . NWS101, 141, 201—204, 301, 401 • OVD021, 022, 023, 031 . TDS messages . XMI messages 	Network Equipment
<ul style="list-style-type: none"> • BSD301, 401, 402 . ERR4062 . NWS301, 401, 501 . OVD001—010, 024 • XMI messages 	Peripheral Equipment
<ul style="list-style-type: none"> . ERR090, 220, 270 . OVD001—010 . TRK messages 	Trunk
<ul style="list-style-type: none"> . BSD501 	Attendant console
<ul style="list-style-type: none"> . BSD501 . ERR500 . MWL500 . NWS501 . OVD001—010 	Telephone set

Visual fault indicators

There are visual indicators on the **SL- 1** that can help you identify faults. These indicators include:

- A major or minor alarm display on the attendant console: indicates a possible power, Common Equipment, or Network Equipment fault
- Circuit card Light Emitting Diodes (**LEDs**): indicates a card or a unit on a card is disabled
- Column LED: indicates a fault in the column

Table 3 lists visual indicators you may see and the type of fault they might indicate.

Table 3
Visual fault indicators and related fault types

indicator	Type of fault
<ul style="list-style-type: none"> . Major alarm on attendant consoles . Red LED lit on column top cap . Green LED off on UEM power supply . Circuit breaker tripped (down) . Remote alarm 	Power
<ul style="list-style-type: none"> . Major alarm on attendant consoles . Red LED lit on CE card 	Common Equipment
<ul style="list-style-type: none"> . Minor alarm on an attendant console . Red LEDs lit or flashing on cards 	Network Equipment
<ul style="list-style-type: none"> . Red LED lit on associated card 	Peripheral Equipment
<ul style="list-style-type: none"> . Red LED lit on trunk card 	T r u n k
<ul style="list-style-type: none"> . Red LED lit on associated cards 	Attendant console
<ul style="list-style-type: none"> . Red LED lit on associated cards 	Telephone set

Maintenance display codes

Maintenance displays **are** located on the faceplate of some SL-1 circuit cards. A maintenance display shows an alphanumeric code which can indicate the status of the system and aid in fault identification. Interpretations of the maintenance display codes-are listed under "HEX" in **the X11 input/output guide** (553-3001-400).

Each new code shown on a maintenance display overwrites **the** one before it. However, all codes received on Common Equipment displays are recorded, you can review them by printing the History File. The most recent 16 codes displayed on a Controller Card stay in memory. You can review them and reset the counter through the Network and Signaling Diagnostic (**LD 30**). You should examine previous codes, system messages, and visual indicators with the current maintenance display code to properly analyze faults.

Table 4 lists the cards with maintenance displays and the type of fault they might indicate.

Table 4
Maintenance display locations and related fault types

Maintenance display	Type of fault
<ul style="list-style-type: none"> . QPC580 CPU Interface Card . QPC584 Mass Storage Interface Card . QPC687 CPU Card • QPC742 Floppy Disk Interface Card 	Common Equipment
. NT8D01AC or NT8D01AD Controller Card	Peripheral Equipment

User reports

Many faults reported by users, such as a damaged telephone or data set, are obvious and can be fixed by replacing the damaged equipment.

Some faults are less obvious and may be caused by other equipment, such as a defective Peripheral Equipment card. To classify the fault in these cases, check for system messages and visual fault indications. You may also have the user reproduce the problem so you can determine the sequence of events that led to the fault.

Table 5 lists typical problems reported by users and the type of fault they might indicate.

Table 5
User reported problems and related fault types

User report	Type of fault
<ul style="list-style-type: none"> . Major alarm reported by attendant . No ring on 500/2500-type telephone sets 	Power
<ul style="list-style-type: none"> . Major alarm reported by attendant . Minor alarm reported by attendant 	Common Equipment
<ul style="list-style-type: none"> . Cannot transfer or conference . Cannot dial out on 500/2500-type telephone sets 	Network Equipment
<ul style="list-style-type: none"> . Trouble with calls on attendant console . Trouble with calls on 500/2500-type telephone sets . Trouble with calls on SL-1, MI 000, or digital telephone sets 	Peripheral Equipment
<ul style="list-style-type: none"> . Trouble with a specific trunk . Continuous ringing 	Trunk
<ul style="list-style-type: none"> . Trouble with calls on console and/or telephone sets 	
<ul style="list-style-type: none"> . Trouble with calls . Trouble with equipment (such as handset, headset, or display) 	Attendant console
<ul style="list-style-type: none"> . Trouble with calls . Trouble with equipment (such as handset or add-on module) 	Telephone set



Accessing the system

Chapter contents

Introduction	13
Access through the system terminal	14
Access through the maintenance telephone	16

Introduction

When replacing equipment, you will send maintenance commands to the SL-1 to software disable faulty equipment and to software enable and test newly installed equipment.

You send maintenance commands to the system through the system terminal or the maintenance telephone. This chapter gives the procedures for accessing the system through these devices.

Access through the system terminal

You can send maintenance commands and receive system messages by accessing the CPU through an RS-232 device, such as a video display terminal (VDT).

When you access the system through a system terminal, a log in procedure is required (see Procedure 2). All system passwords are initially set as 0000, but you can change passwords through the Configuration Record (LD 17).

Note: If a sysload (system reload) occurs before you save a new password in a data dump, the last active password remains valid.

Each system has two levels of passwords: level 1 is for general use, level 2 is for administrative use. Either password is accepted in the log in procedure.

Procedure 2
Accessing the system terminal

- 1 Press the return key.
 - If the response is **OVLIII nn TTY** or **OVLIII nn SL1** someone else is logged into the system. When they have logged off, press return and go to Step 2.
 - If the response is **OVLIII nn IDLE** or **OVLIII nn BKGD** **you** are ready to log into the system. Go to Step 2.
 - If the response is **OVL000 >** **you** are already logged into the system. Go to Step 4.

Note: Responses vary with different Background Terminal packages.

- 2 Enter **LOCI** then press the return key.

The normal response is **PASS?**
If there is any other response, see the XII *input/output guide* (553-3001-400).
- 3 Enter either the level 1 or level 2 password and press the return key. If the password is correct, the system responds with the prompt **>**
- 4 Enter **LD xx** “xx” represents the number of the program.
- 5 Perform tasks.
- 6 End the program by entering ********
- 7 End the log in session with **LOGO**
Background routines are then loaded automatically.

Access through the maintenance telephone

A telephone set functions as a maintenance telephone when you **define** the class-of-service as MTA (maintenance set allowed) in the SL-1 Telephone Sets program (LD 11). A maintenance telephone allows you to send commands to the system, but you can only use **a subset** of the commands that can be entered from a system terminal. The maintenance telephone, however, takes priority over a system terminal and will log the terminal out.

You can test tones and outpulsing through the maintenance telephone. Specific commands for those tests are given in the Tone and Digit Switch and **Digitone** Receiver Diagnostic (LD 34).

No log in procedure is required when you access the system through a maintenance telephone (see Procedure 3). To enter commands, press the keys that correspond to the letters and numbers of the command (for example, to enter **LD 42 return**, key in **53#42##**). Table 6 shows the translation from a terminal keyboard to a telephone dial pad.

Note: To use the maintenance telephone, the Peripheral Equipment loop for that telephone must be operating.

Table 6
Translation from keyboard to dial pad

Keyboard			Dial pad
			1
A	B	C	2
D	E	F	3
G	i-i	I	4
J	K	L	5
M	N	O	6
P	R	S	7
T	U	V	8
w	x	Y	9
			0
		Space or #	#
		Return	##

Note: There is no equivalent for Q or Z on a dial pad.

Procedure 3 Accessing the maintenance telephone

- 1 Press the prime DN key.
- 2 Place the set in maintenance mode by entering
xXxX91
“xxxx” represents the customer Special Prefix (SPRE) number. It is defined in the Customer Data Block and can be printed using LD 21. The SPRE number is typically “1” (which means you would enter 191).
- 3 Check for busy tone by entering

 - If there is no busy tone, go to Step 4.
 - If there is a busy tone, a program is active. To end an active program and access the system, enter

- 4 Load a program by entering
53#xx##
“xx” represents the number of the program.
- 5 Perform tasks.
- 6 Press the release key to return the set to call processing mode. Background routines are then loaded automatically.



Clearing power faults

Chapter contents

Power faults	20
Fault clearing procedures	24
Symptoms:	
Main circuit breaker and all LEDs off (system option 21A)	27
Main circuit breaker on but all LEDs off (system option 21 A)	28
Green LED off on UEM power supply (system option 21A)	30
Circuit breakers and all column LEDs off (DC power)	31
Circuit breakers on but all column LEDs off (DC power)	33
Green LED off on UEM power supply (DC power)	-34
Defective Blower or Fan Unit indicated (DC power)	36
Main circuit breaker and all column LEDs off (AC power)	37
Main circuit breaker on but all column LEDs off (AC power)	39
Breaker off on Module Power Distribution Unit (AC power)	41
Green LED off on UEM power supply (AC power)	43
Defective Blower or Fan Unit indicated (AC power)	45

Power faults

Various electrical voltages are required to power the SL-1. These electrical voltages are developed and delivered by the power equipment system. Cooling and monitoring devices are interconnected with the power system. Figures 1, 2, and 3 show power, cooling, and monitoring equipment that may be located in a column, including:

- Air Probe: increases the fan speed as the temperature goes up (not equipped in system option 21A)
- Blower or Fan Unit: provides cooling for the column (not equipped in system option 21A)
- Module Power Distribution Unit (**MPDU**): houses circuit breakers for some UEM power supplies (AC power only and not equipped in system option 21A)

Note: In DC-powered systems, there is a switch on each power supply, so **MPDUs** are not required.

- Power Distribution Unit (**PDU**): distributes power from the external source to UEM power supplies and houses the column circuit breaker(s)
- UEM Power Supply: converts voltage from the PDU to the voltages needed in each type of UEM
- Ringing Generator: provides current to ring **500/2500-type** telephone sets and to light the Message Waiting light on **2500-type** sets
- System Monitor: monitors power and temperature conditions
- Thermostat: monitors column temperature
- Top Cap Fan: cools the power supply (system option 21 A only)

Power faults can disable ringing for **500/2500-type** telephone sets, Message Waiting lights on **2500-type** telephone sets, all the cards in a UEM, all the UEMs in a column, or the entire system.

Figure 1
Power equipment — system option 21A

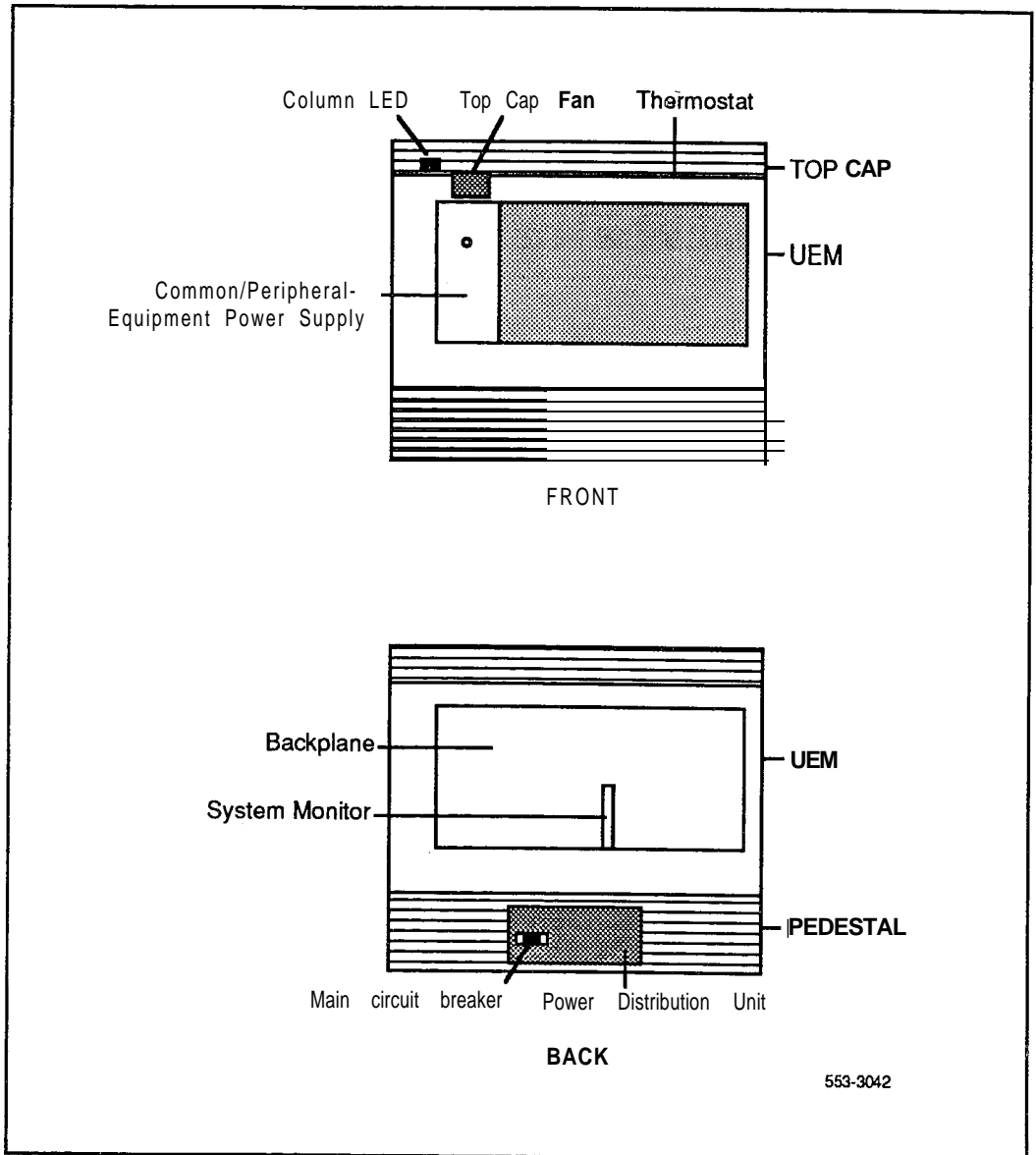

Figure 2
Internal DC power equipment (except system option 21 A)

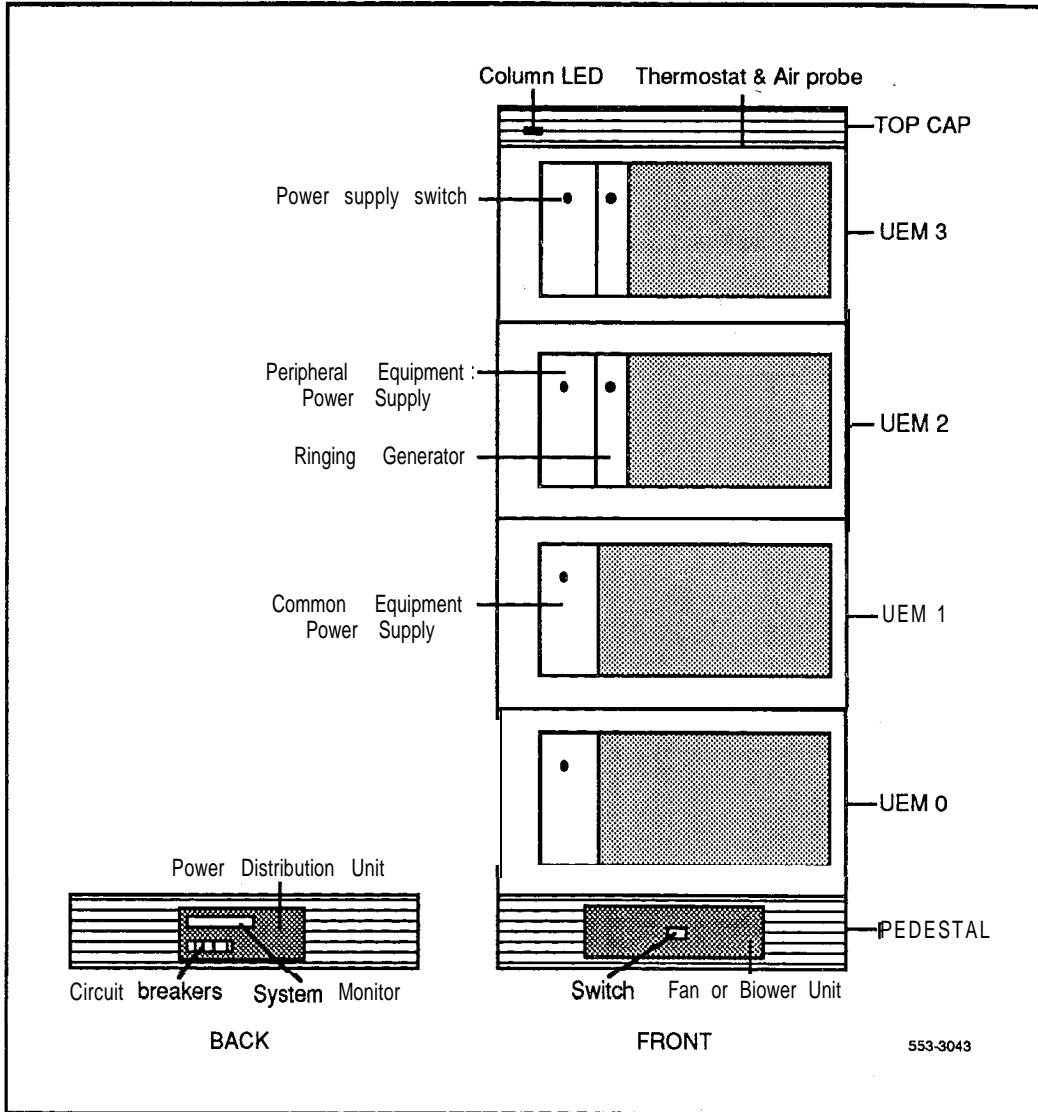
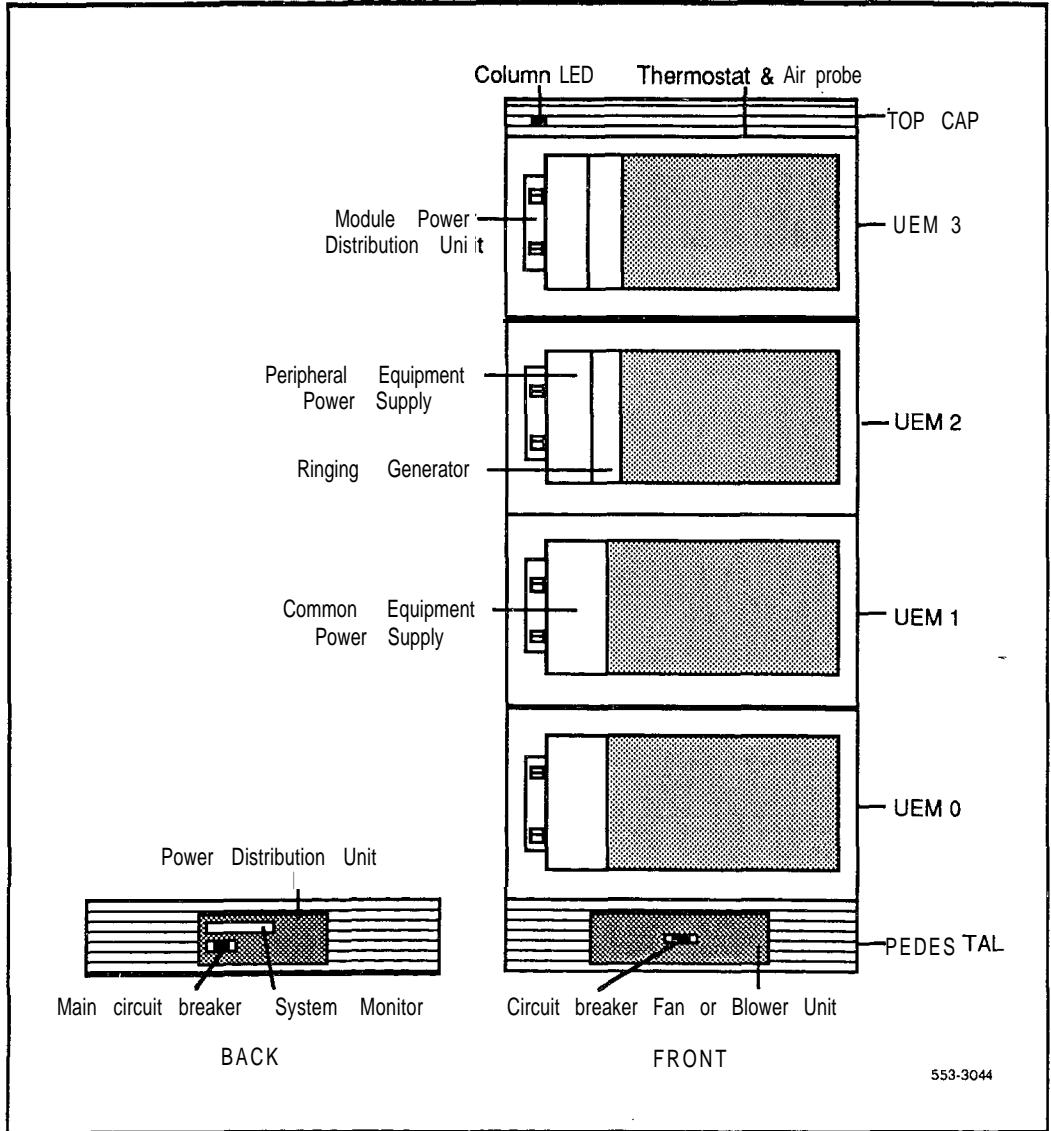

Figure 3
Internal AC power equipment (except system option 21A)



Fault clearing procedures

System messages with the mnemonic PWR (power) contain four fields of information about power equipment. These fields identify the type of equipment indicated (such as the Blower Unit) and the source of the message (System Monitor, UEM, and UEM power supply). Table 7 defines the fields in PWR messages. Figure 4 shows the power equipment identified in PWR messages.

Table 7
PWR message fields

PWRxxxx (field 1) (field 2) (field 3) (field 4)	
Field 1	Hardware type, one of the following:
	CRBK Circuit breaker
	DCSP DC power supply
	FANU Blower or Fan Unit
	PFTC Power Fail Transfer
	PWSP UEM power supply
	THSW Thermal switch
	UPSA Uninterruptible Power Supply
	XSMC System Monitor
Field 2	System Monitor (O-63) generating the message
Field 3	UEM (O-3) reporting the condition
Field 4	Number of the power supply (I-2) in the UEM

Figure 4
Power equipment designations

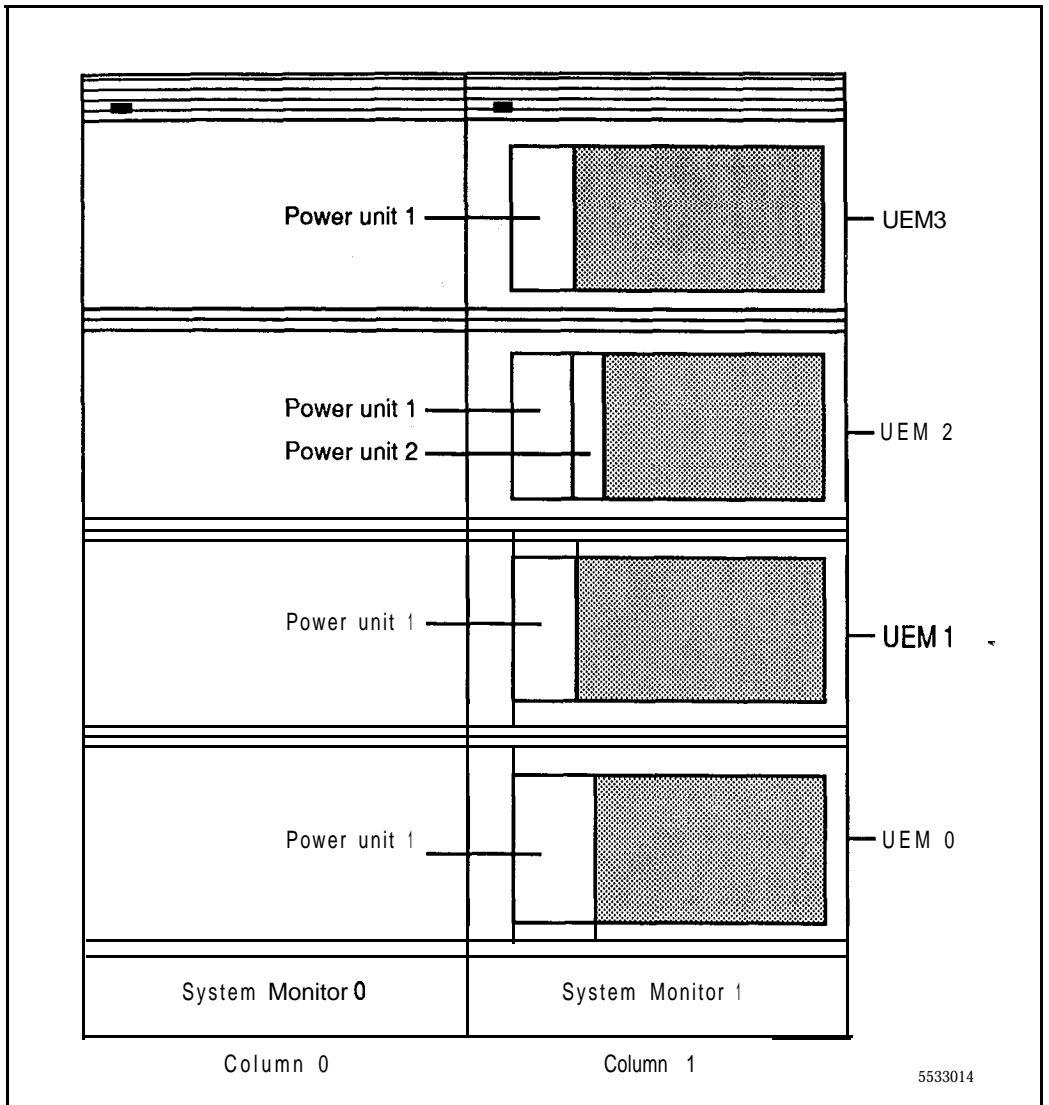

Table 8 lists common power fault indications. To **clear** faults, select **the** symptom in “Chapter contents” that most resembles the fault indications then go through the procedure for clearing each possible cause until **the** fault is fixed. Once **the** fault is corrected, disregard the remaining possible causes.

Note: You must clear power faults before you try to clear other **types** of faults in the system.

If the fault is not cleared after you have gone through each possible cause, check the most recent fault indications. Also check “How to clear faults” to see if another type of fault is indicated.

After the fault is corrected, go to “Final maintenance procedure” to completely restore normal operation.

Table 8
Power fault indications

Indicator	Possible indications
System messages	<ul style="list-style-type: none"> • BSD090 (Program has detected a power fault indication. Check PWR messages.) • PWR messages
Visual indicators	<ul style="list-style-type: none"> • Major alarm on attendant consoles • Red LED lit on column top cap • Green LED off on UEM power supply • LED lit on PFTU • Circuit breaker tripped (down) • Remote alarm
User reports	<ul style="list-style-type: none"> • Major alarm reported by attendant • No ring on 500/2500-type telephone sets

WARNING

UEM covers are *not* hinged; do *not* let go of the cover. Lift the cover away from the UEM and set it out of your work area.

Symptom: Main circuit breaker and all LEDs off (system option 21A)

All the LEDs in the system are off and the main circuit breaker on the Power Distribution Unit is tripped. Use this procedure to clear the problem.

Note: High room temperature or a power surge can shut down the system. Check for these external conditions.

Replace equipment as described *in Hardware replacement (553-3001-520)*. You may need to replace:

- Thermostat Harness: NT8D46AC
- Top Cap Fan: A0367754
- System Monitor cables

Possible cause	Action
Short circuit or damage	<p>Look for signs of damage (such as smoke, burnt contacts, or melted insulation) that may be caused by a short circuit or misplaced equipment.</p> <p>If you do not find a problem of this type, go to the next possible cause.</p>
Thermal overload	<p>Make sure nothing is blocking ventilation throughout the system. Allow the system to cool for a few minutes then reset the breaker.</p> <p>If the breaker trips immediately, check the Thermostat Harness</p> <ul style="list-style-type: none"> — make sure the harness is securely connected to the UEM — use an ohm meter to check the connector pins for the harness; if there is an open circuit between pins 3 and 4 or between pins 5 and 6, replace the harness <p>If the breaker does not trip immediately, listen for the sound of the Top Cap Fan. If you do not hear the fan, replace it.</p> <p>If there is no problem with this equipment, go to the next possible cause.</p>
Defective connection to System Monitor	<p>Make sure the cable to connector J3 is securely connected to the System Monitor. Also check the System Monitor connection to the UEM.</p> <p>If the breaker trips with all cables connected, replace the cables one-at-a-time until the breaker stays on.</p>

Symptom:
Main circuit breaker on but all LEDs off (system option 21 A)

All the **LEDs** in the system are off but the main circuit breaker on the Power Distribution Unit is not tripped. Use this procedure to clear the problem.

Replace equipment as described in *Hardware replacement* (553-3001-520). You may need to replace:

- Power Distribution Unit (system option 21A): **NT8D53AD**
- Main power cord
- Uninterruptible Power Supply (UPS)

Possible cause	Action
Power cord not connected	If the power cord for the column is unplugged, plug it in. If the power cord is already plugged in or if the column LEDs do not light and the breaker trips when reset, go to the next possible cause.

WARNING
The following tests are performed on a live power connection.

No power at outlet	With a meter or test lamp, test for AC power at the outlet. If there is no power at the outlet when AC power is supplied through a UPS unit, repair or replace the UPS following the manufacturer's instructions. If there is no power at the outlet when AC power is supplied through commercial service (not through a UPS), take the necessary steps to have the commercial power restored. If there is power at the outlet, go to the next possible cause.
--------------------	---

Defective power cord With a meter or test lamp, test the field **wiring** connections (behind the **PDU**) for AC power.

If there is no power, replace the power cord.

If there is power at the connections, go to the next possible cause.

Defective PDU Replace the PDU.

Symptom: Green LED off on UEM power supply (system option 21A)

The green LED is off on the Common/Peripheral Equipment Power Supply, but the main circuit breaker on the Power Distribution Unit not tripped. Use this procedure to clear the problem.

You may need to replace the **NT7D14AA** Common/Peripheral Equipment Power Supply. Replace equipment **as** described in **Hardware replacement** (553-3001-520).

Possible cause	Action
Disconnected power cable	Check the power cable connection to the power supply (see Figure 5). If all power cables are connected, go to the next possible cause.
Defective power supply	Set the switch on the power supply to OFF (down), wait at least 60 seconds, then set the switch back to ON (up). If the LED on the power supply is still off, replace the power supply.

Figure 5
System option 21A power cabling in back of column

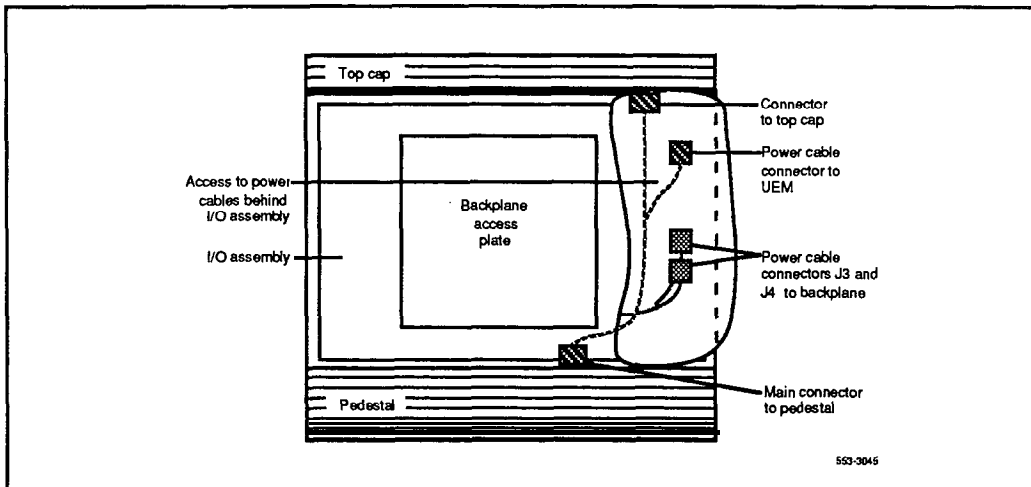

Symptom: Circuit breakers and all column LEDs off (DC power)

All the **LEDs** in a column are off and all circuit breakers on the Power Distribution Unit are tripped. You may receive message **PWR0004**, which indicates the circuit breakers for the column have tripped. See "**PWR**" in **the XII input/output guide (553-3001-400)** and use this procedure to clear the problem.

Note: High room temperature can shut down the system. If all columns in a multi-column system are shut down, check for this external condition.

Replace equipment as described in **Hardware replacement (553-3001-520)**. You may need to replace:

- Air filter: **PO699798**
- Air Probe Harness: **NT8D46AM**
- System Monitor cables
- Thermostat harness: **NT8D46DC**

Possible cause	Action
Low batteries	<p>If a TRIP signal to the system has shut down power</p> <ul style="list-style-type: none"> — check the cable from the QBL15 Power/Battery Distribution Box or QCA13 Power Plant — check the batteries and service them as necessary
Short circuit or damage	<p>Look for signs of damage (such as smoke, burnt contacts, or melted insulation) that may be caused by a short circuit or misplaced equipment.</p> <p>If you do not find a problem of this type, go to the next possible cause.</p>
Thermal overload	<p>Make sure nothing is blocking ventilation throughout the system. Allow the system to cool for a few minutes then reset the breakers,</p>

-continued —

Possible cause	Action
Defective connection to System Monitor	<p>If the breakers trip immediately, check the Thermostat Harness</p> <ul style="list-style-type: none">— make sure the harness is securely connected to the UEM below it— use an ohm meter to check the connector pins for the harness; if there is an open circuit between pins 3 and 4 or between pins 5 and 6, replace the harness <p>If the breakers do not trip immediately, check the air filter. Clean or replace a dirty or damaged filter <i>as</i> described in General <i>maintenance information</i> (553-3001-500).</p> <p>If there is no problem with the air filter or if the breakers trip when reset, check the Air Probe Harness</p> <ul style="list-style-type: none">— make sure the harness is securely connected to the UEM below it— use an ohm meter to check the connector pins for the harness; if there is an open circuit between pins 1 and 2, replace the harness <p>If there is no problem with this equipment, go to the next possible cause.</p> <p>Make sure cables to connectors J5 and J6 are securely connected to the System Monitor in the column.</p> <p>Check the System Monitor connections to each UEM.</p> <p>If the breakers trip with all cables connected, replace the cables one-at-a-time until the breakers stay on.</p>

Symptom: Circuit breakers on but all column LEDs off (DC power)

All the **LEDs** in a column are off but the circuit breakers on the Power Distribution Unit are not tripped. Use this procedure to clear the problem.

Replace equipment as described in *Hardware replacement* (553-3001-520). You may need to replace:

- NT6D52AA Rectifier
- Power Distribution Unit (PDU): NT7D10AA

Possible cause	Action
DC wires not connected	<p>If the DC wires are disconnected, connect them.</p> <p>If the wires are already connected or if the column LEDs do not light when they are connected, go to the next possible cause.</p>
<p>WARNING</p> <p>The following test is performed on a live power connection.</p>	
No power at DC source	<p>Make sure the rectifier is on and connected.</p> <p>Make sure the rectifier is receiving power.</p> <p>If there is no problem with the rectifier, go to the next possible cause.</p>
Defective power cable	<p>With a meter, test the field wiring connections in the PDU for DC power.</p> <p>If there is no power, replace the cable.</p> <p>If there is power at the connections, go to the next possible cause.</p>
Defective PDU	Replace the PDU.

Symptom: Green LED off on UEM power supply (DC power)

The green LED is off on one of the following power supplies:

- Peripheral Equipment Power Supply DC: NT6D40AA
- Common Equipment Power Supply DC: NT6D4 1 AA
- Ringing Generator DC: NT7D03AA
- Common/Peripheral Equipment Power Supply DC: NT7D04AA

You may receive a system message indicating the status of the power supply. See "PWR" in the *XII input/output guide* (553-3001-400) and use this procedure to clear the problem.

Replace equipment as described in *Hardware replacement* (553-3001-520).

Possible cause	Action
Disconnected power cable	Check the power cable connection to the power supply. If the cable is connected, check power cable connections to each UEM below the affected one (see Figure 6). If all power cables are connected, go to the next possible cause.
Defective power supply	Set the switch on the power supply to OFF (down), wait at least 60 seconds, then set the switch back to ON (up). If the LED on the power supply is still off, replace the power supply.

Figure 6
DC power cabling in back of column

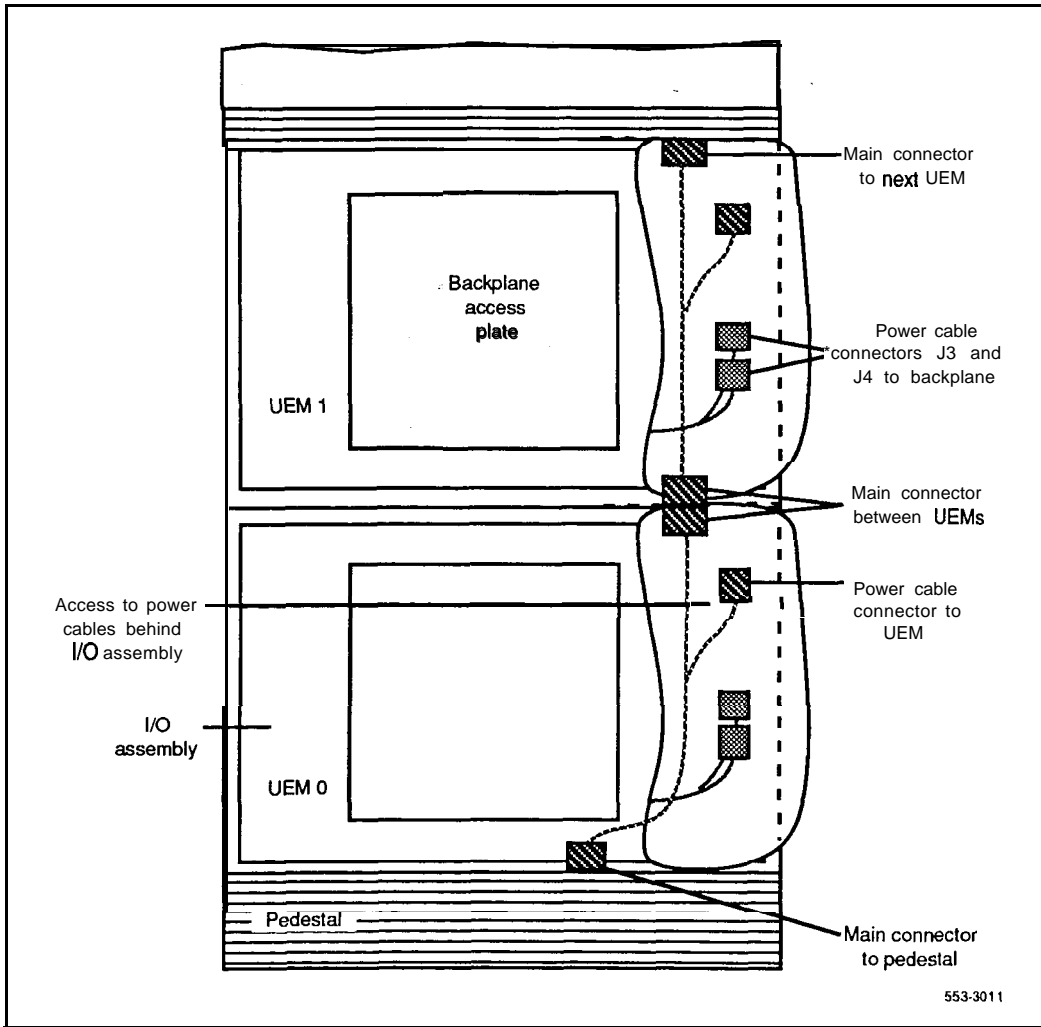

Symptom: Defective Blower or Fan Unit indicated (DC power)

The Blower or Fan Unit circuit breaker (breaker number 5 on the Power Distribution Unit) is tripped and trips when reset. You may receive a system message indicating there is a failure in the fan or blower. See "PWR" in the XII *input/output guide (553-3001-400)* and use this procedure to clear **the** problem.

Replace equipment as **described in Hardware replacement (553-3001-520)**. You may need to replace:

- Blower or Fan Unit: NT8D52DC, NT7D17DC
- Power Distribution Unit (PDU): NT7D10AA

Possible cause	Action
Blower or Fan Unit switch turned off	Set the switch on the front of the Blower or Fan Unit to ON (right), Reset the circuit breaker. If the switch was already on or if the circuit breaker trips again, go to the next possible cause.
Defective Blower or Fan Unit	Replace the Blower or Fan Unit and set the circuit breaker to on. If the breaker trips, go to the next possible cause.
Defective PDU	Replace the PDU.

Symptom: Main circuit breaker and all column LEDs off (AC power)

All the LEDs in a column are off and the main circuit breaker on the Power Distribution Unit is tripped. You may receive **message.PWR0004**, which indicates the main circuit breaker for the column has tripped. See "PWR" in *the XII input/output guide (553-3001-400)* and use this procedure to clear the problem.

Note: High room temperature or a power surge can shut down the system. If all columns in a multi-column system are shut down, check for these external conditions.

Replace equipment as described in *Hardware replacement (553-3001-520)*. You may need to replace:

- Air filter: PO699798
- Air Probe Harness: NT8D46AM
- System Monitor cables
- Thermostat harness: NT8D46AC

Possible cause	Action
Short circuit or damage	<p>Look for signs of damage (such as smoke, burnt contacts, or melted insulation) that may be caused by a short circuit or misplaced equipment.</p> <p>If you do not find a problem of this type, go to the next possible cause.</p>
Thermal overload	<p>Make sure nothing is blocking ventilation throughout the system. Allow the system to cool for a few minutes then reset the breaker.</p> <p>If the breaker trips immediately, check the Thermostat Harness</p> <ul style="list-style-type: none"> — make sure the harness is securely connected to the UEM below it — use an ohm meter to check the connector pins for the harness; if there is an open circuit between pins 3 and 4 or between pins 5 and 6, replace the harness <p>If the breaker does not trip immediately, check the air filter. Clean or replace a dirty or damaged filter as described in <i>General maintenance information (553-3001-500)</i>.</p>

-continued —

Possible cause	Action
	<p>If there is no problem with the air filter or if the breaker trips when reset, check the Air Probe Harness</p> <ul style="list-style-type: none">— make sure the harness is securely connected to the UEM below it <p>use an ohm meter to check the connector pins for the harness; if there is an open circuit between pins 1 and 2, replace the harness</p> <p>If there is no problem with this equipment, go to the next possible cause.</p>
Defective connection to System Monitor	<p>Make sure cables to connectors J5 and J6 are securely connected to the System Monitor in the column.</p> <p>Check the System Monitor connections to each UEM.</p> <p>If the breaker trips with the cables connected, replace the cables one-at-a-time until the breaker stays on.</p>

Symptom: Main circuit breaker on but all column LEDs off (AC power)



All the LEDs in the column are off but the-main **circuit breaker** on the Power Distribution Unit is not tripped. Use this procedure to clear the problem.

Replace equipment as described in **Hardware replacement** (553-3001-520). You may need to replace:

- Power Distribution Unit AC: NT8D53AB
- Main power cord
- Uninterruptible Power Supply (UPS)

Possible cause	Action
Power cord not connected	If the power cord for the column is unplugged, plug it in. If the power cord is already plugged in or if the column LEDs do not light when it is plugged in, go to the next possible cause.

WARNING
The following tests are performed on a live power connection.

No power at outlet	With a meter or test lamp, test for AC power at the outlet. If there is no power at the outlet when AC power is supplied through a UPS unit, repair or replace the UPS following the manufacturer's instructions. If there is no power at the outlet when AC power is supplied through commercial service (not through a UPS), take the necessary steps to have the commercial power restored. If there is power at the outlet, go to the next possible cause.
--------------------	---

- continued -



Possible cause	Action
Defective power cord	With a meter or test lamp, test the field wiring connections in the PDU for AC power. If there is no power, replace the power cord. If there is power at the connections, go to the next possible cause.
Defective PDU	Replace the PDU.

Symptom: Breaker off on Module Power Distribution Unit (AC power)

A circuit breaker on a Module Power Distribution Unit (MPDU) is tripped and trips when reset. The green LED will be off on the associated power supply:

- NT8D56AA single breaker MPDU — NT8D29AA Common Equipment Power Supply AC
- NT8D56AC single breaker MPDU — NT7D14AA Common/Peripheral Equipment Power Supply AC
- NT8D57AA dual breaker MPDU — NT8D06AA Peripheral Equipment Power Supply AC and NT8D21AA Ringing Generator AC

You may receive a system message indicating the status of the breaker. **See "PWR"** in the *X11 input/output guide* (553-3001-400) and use this procedure to clear the problem.

Replace equipment as described in **Hardware replacement** (553-3001-520).

Possible cause	Action
Short circuit or damage	Look for signs of damage (such as smoke, burnt contacts, or melted insulation) that may be caused by a short circuit or misplaced equipment. If you do not find a problem of this type, go to the next possible cause.
Defective UEM power supply (single breaker)	Unseat the associated power supply and reset the breaker. If the breaker does not trip, replace the power supply. If the breaker trips, replace the MPDU.
Defective UEM power supply (dual breaker)	If one circuit breaker is tripped on a dual MPDU <ul style="list-style-type: none"> — unseat the associated power supply (see Figure 7) then reset the breaker — if the breaker does not trip, replace the power supply — if the breaker trips, replace the MPDU

-continued -

Possible cause	Action
	<p>If both circuit breakers are tripped</p> <ul style="list-style-type: none"> — unseat both power supplies then reset the breakers — if either breaker or both breakers trip, replace the MPDU <p>If the breakers do not trip, set them to OFF (down)</p> <ul style="list-style-type: none"> — reinsert one power supply then reset the associated breaker — if the breaker trips, replace that power supply — if the breaker does not trip, set the breaker to OFF and unseat that power supply — reinsert the other power supply then reset the associated breaker — if the breaker trips, replace that power supply

Figure 7
Dual circuit breaker and associated UEM power supplies

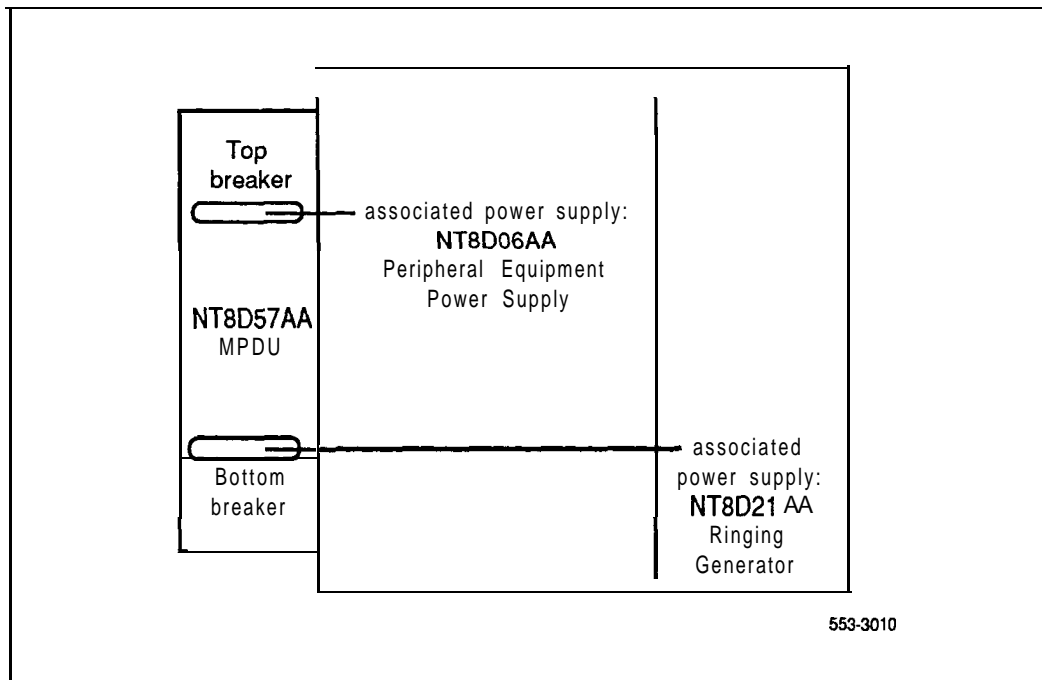

Symptom: Green LED off on UEM power supply (AC power)

The circuit breaker on the associated Module Power Distribution Unit (MPDU) is not tripped, but the green LED is off on one of the following power supplies:

- Peripheral Equipment Power Supply AC: **NT7D14AA**
- Common Equipment Power Supply AC: **NT8D06AA**
- Ringing Generator AC: **NT8D21AA**
- Common/Peripheral Equipment Power Supply AC: **NT8D29AA**

You may receive a system message indicating the status of the power supply. See "PWR" in the ***X11 input/output guide*** (553-3001400) and use this procedure to clear the problem.

Replace equipment as described in ***Hardware replacement*** (553-3001-520).

Possible cause	Action
Disconnected power cable	<p>Check the power cable connection between the power supply and the back of the MPDU.</p> <p>If the cable is connected, check power cable connections to each UEM below the affected one (see Figure 8).</p> <p>If all power cables are connected, go to the next possible cause.</p>
Defective power supply	<p>Set the circuit breaker on the associated MPDU off then back on (see Figure 7 if there are dual circuit breakers).</p> <p>If the LED on the power supply is still off, replace the power supply.</p> <p>If you replace the power supply, the LED on the replacement should light and stay lit. If it does not, go to the next possible cause.</p>
Defective MPDU	Replace the MPDU.

Figure 8
AC power cabling in back of column

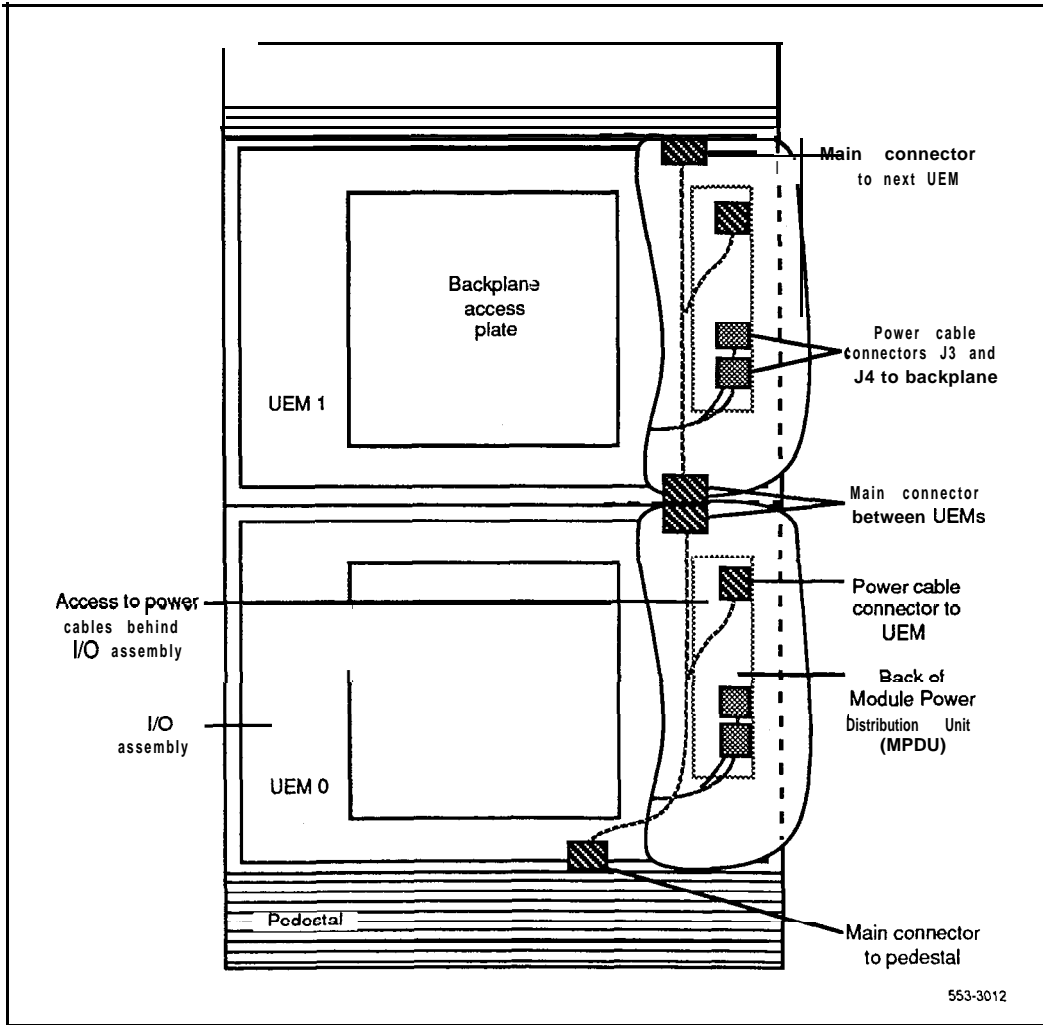

Symptom: Defective Blower or Fan Unit indicated (AC power)

The Blower or Fan Unit circuit breaker (located on the front of the unit) is tripped and trips when reset. You may receive a system message indicating there is a failure in the fan or blower. See "PWR" in the XII *input/output guide* (553-3001-400) and use this procedure to clear the problem.

Replace equipment as **described in *Hardware replacement*** (553-3001-520). You may need to replace:

- Blower or Fan Unit: NT8D52AA, NT7D17AC
- Power Distribution Unit (PDU): NT8D53AB

Possible cause	Action
Defective Blower or Fan Unit	Replace the Blower or Fan Unit and set the circuit breaker to ON (up). If the breaker trips, go to the next possible cause.
Defective PDU	Replace the PDU.



Clearing Common Equipment faults

Chapter contents

Common Equipment faults	48
Fault clearing procedures	48
Symptoms:	
Call processing stopped (system option 21)	49
Fault indicated on Memory/Peripheral Signaling Card (system option 21)	52
Fault indicated on the CPU card (system option 21)	53
Call processing stopped (system option 51)	55
Fault indicated on Memory Card (system option 51)	58
Fault indicated on a Common Equipment card (system option 51)	60
Call processing stopped (system options 61 and 71)	62
Fault indicated on a Memory Card (system options 61 and 71)	65
Fault indicated on a Common Equipment card (system options 61 and 71)	68
Floppy Disk Unit not operating	71
Multi Disk Unit not operating	72

Common Equipment faults

Common Equipment (CE) functions perform system control and switching. Common Equipment in the SL-1 can include:

- Bus Terminating **Unit**: provides logical termination to CPU and network buses (system options **51, 61,** and 71)
- Changeover and Memory Arbitrator: provides CPU access to RAM memory; allows a CPU to access redundant memory in a dual CPU system (system options **51, 61,** and 71)
- CPU: performs system arithmetic and logic functions
- Data Cartridge: allows access to only software packages purchased
- Mass Storage Interface: interfaces between the CPU and the mass storage unit
- Mass Storage Unit: provides a backup for programs and data stored in system memory
- Read Only Memory: provides memory (ROM) for the CPU
- Serial Data Interface: provides ports between the CPU and external devices
- Segmented Bus Extender: extends the CE bus to Network Equipment (system option 71)
- Three-Port Extender: extends CPU signals to the network, or between the SBE and the network (system options 61 and 71)

Common Equipment faults can disable the CPU or the mass storage unit and stop call processing. In addition, other types of equipment (such as Network Equipment) may not operate properly while there is a CE fault in the system.

Fault clearing procedures

Table 9 lists Common Equipment (CE) fault indications. To clear faults, select the symptom in “Chapter contents” that most resembles the fault indications and go through the procedure for clearing each possible cause until the fault is fixed. Once the fault is corrected, disregard the remaining possible causes.

Note: Clear any power faults before you try to clear Common Equipment faults.

If **the** fault is not cleared after you have gone through each possible cause, check the most recent fault indications. Also check “How to clear faults” to see if another type of fault is indicated.

After the fault is corrected, go to “Final maintenance procedure” to completely restore normal operation.

Table 9
Common Equipment fault indications

indicator	Possible indications
System messages	<ul style="list-style-type: none"> . BSD080, 085, 086, 103 . CED messages . INI001, 002, 004, 005, 007 . IOD006, 007, 060, 061, 291—297 . NWS030, 102, 103, 142 . SYS messages
Visual indicators	<ul style="list-style-type: none"> ▪ Major alarm on attendant consoles . Red LED lit on column top cap . Red LED lit on CE card
Maintenance displays	<ul style="list-style-type: none"> ▪ QPC580 CPU Interface (IF) . NT8D19AA Memory/Peripheral Signaling . QPC583 Mass Storage Interface (MSI) . QPC742 Floppy Disk Interface (FDI)
User reports	<ul style="list-style-type: none"> . Major alarm reported by attendant

WARNING

UEM covers are **not** hinged; do not let go of the cover. Lift the cover away from the UEM and set it out of your work area.

Symptom:
Call processing stopped (system option 21)

Call processing has stopped on a single CPU system. Look up all system messages and maintenance display codes in **the XII input/output guide**

(553-3001-400) and follow the instructions given. If the fault does not clear, use this procedure.

Note: Be sure to take any action indicated by the maintenance display codes. Constantly observe and look up codes and system messages as you perform this procedure.

For information on switch settings, **see *Circuit pack installation and testing (553-3001-211)***. Replace equipment **as** described in ***Hardware replacement (553-3001-520)***. You may need to replace:

- CPU Card: QPC687
- Data Cartridge: QMM42
- Floppy Disk Interface (FDI) Card: QPC742
- Floppy Disk Unit (FDU): NT8D68AA
- Memory/Peripheral Signaling Card: NT8D 19AA
- Read Only Memory (ROM) Card: QPC940
- Common/Peripheral Equipment Card Cage Assembly: NT8D1103

Possible cause	Action
Defective UEM power supply	Make sure the green LED on the Common/Peripheral Equipment Power Supply is lit. If it is not lit, go to “Clearing power faults.” If the power supply LED is lit, go to the next possible cause.
Initialization required	Press the manual initialize (MAN INT) button on the Memory/Peripheral Signaling Card. If the system initializes, check all fault indicators and clear any faults indicated. If the system does not initialize, unseat network cards one-at-a-time. If the system initializes, replace the last card you removed (it is faulty). If the system will not initialize, go to the next possible cause.

Defective FDI or FDU	<p>Unseat the FDU and FDI then reinstall them. Make sure the cable between the FDU and FDI is securely connected. If the system does not recover, continue with this procedure.</p> <p>If a disabled FDI is indicated</p> <ul style="list-style-type: none"> — make sure the Data Cartridge is securely attached — check the switch settings; if necessary, correct the switch settings — try to enable the FDI (try to software disable, hardware disable, then reenable) — if you cannot load a program or the FDI is still disabled, replace it — if necessary, replace the Data Cartridge <p>If a disabled FDU is indicated</p> <ul style="list-style-type: none"> — replace it — if the FDU is still disabled, replace the cable between the FDU and FDI <p>If the system does not recover, go to the next possible cause.</p>
Sysload required	<p>Press the reload (reset) button on the CPU Card.</p> <p>If a sysload (reload) occurs, check all fault indicators and clear any faults indicated.</p> <p>If the system will not sysload, go to the next possible cause.</p>
Defective CE card	<p>Unseat the cards then reinstall them. If the system does not recover, check the CPU Card</p> <ul style="list-style-type: none"> — make sure the ROM Card is properly installed on the CPU Card — replace the CPU Card — if necessary, replace the ROM Card <p>If the system will not sysload, replace the Memory/Peripheral Signaling Card.</p> <p>If the system does not recover, go to the next possible cause.</p>
Defective backplane	<p>Replace the card cage assembly in the UEM.</p>

Symptom: Fault indicated on Memory/Peripheral Signaling Card (system option 21)

The red LED is lit on the Memory/Peripheral Signaling Card and call processing has stopped. Look up all **system** messages and maintenance display **codes in the XII input/output guide** (553-3001-400) and follow the instructions given. If the fault does not clear, use this procedure.

Note: Be sure to take any action indicated by the maintenance display codes. Constantly observe and look up system messages as you perform this procedure.

Replace equipment as described **in Hardware replacement** (553-3001-520). You may need to replace:

- CPU Card: QPC687
- Memory/Peripheral Signaling Card: NT8D 19AA
- Read Only Memory (ROM) Card: QPC940
- Common/Peripheral Equipment Card Cage Assembly: NT8D1103

Possible cause	Action
Defective Memory/Peripheral Signaling Card	Unseat the card then reinstall it. If the LED on the card is still lit, replace the card. If the LED turns off but the system does not recover, go to the next possible cause.
Defective CPU Card	Unseat the CPU Card then reinstall it. If the system does not recover <ul style="list-style-type: none"> — make sure the ROM Card is properly installed — as necessary, replace the CPU Card and the ROM Card If the system does not recover, go to the next possible cause.
Defective backplane	Replace the card cage assembly in the UEM.

Symptom: Fault indicated on the CPU card (system option 21)

The red LED is lit on the CPU card. Look up all system messages and maintenance display codes in the *XII input/output guide* (553-3001-400) and follow the instructions given. If the fault does not clear, use this procedure.

Note: Constantly observe and look up system messages as you perform this procedure.

For information on switch settings, *see Circuit pack installation and testing* (553-3001-211). Replace equipment as described in *Hardware replacement* (553-3001-520). You may need to replace:

- CPU Card: QPC687
- Floppy Disk Interface (FDI) Card: QPC742
- Memory/Peripheral Signaling Card: NT8D19AA
- Read Only Memory (ROM) Card: QPC940
- Serial Data Interface (SDI) paddle board: NT8D41AA
- Common/Peripheral Equipment Card Cage Assembly: NT8D1103

Possible cause	Action
Defective FDI (lit LED)	<p>Unseat the card then reinstall it. If the card does not recover</p> <ul style="list-style-type: none"> — make sure the cable between the FDU and FDI is securely connected — check the switch settings; if necessary, correct the switch settings and try to enable the card <p>if you cannot load a program or the card will not enable, replace the card</p> <p>If the CPU is still faulty, go to the next possible cause.</p>

-continued —

Possible cause	Action
Defective SDI	<p>Check each SDI port by entering LD 37 TTY x ("x" represents the number of the interface device attached to the port)</p> <ul style="list-style-type: none">— if software is disabled, try to enable it (software disable, hardware disable, then reenable)— if the card will not enable, replace it <p>If the CPU is still faulty, go to the next possible cause.</p>
CPU Card (lit LED)	<p>Check the CPU Card</p> <ul style="list-style-type: none">— make sure the ROM Card is properly installed— as necessary, replace the CPU Card and the ROM Card <p>If the CPU is still faulty, replace the Memory/Peripheral Signaling Card.</p> <p>If the CPU remains faulty, go to the next possible cause.</p>
Defective backplane	<p>Replace the card cage assembly in the UEM.</p>

Symptom: Call processing stopped (system option 51)

Call processing has stopped on a single CPU system. Look up all system messages and maintenance display **codes** in *the XII input/output guide* (553-3001-400) and follow the instructions given. If the fault does not clear, use this procedure. Before you begin:

- Make sure the normal/maintenance switch on the QPC580 CPU Interface Card is set to **MAINT**.
- Be sure to take any action indicated by the maintenance display codes.

Note: Constantly observe and look up codes and system messages as you perform this procedure.

For information on switch settings, *see Circuit pack installation and testing* (553-3001-211). Replace equipment **as** described in *Hardware replacement* (553-3001-520). You may need to replace:

- Bus Terminating Unit (BTU): QPC477
- Changeover and Memory Arbitrator (CMA) Card: QPC58 1
- CPU Function (FN) Card: QPC579
- CPU Interface (IF) Card: QPC580
- Data Cartridge: QMM42
- Floppy Disk Interface (FDI) Card or Mass Storage Interface (MSI) Card: QPC584 and QPC742
- Floppy Disk Unit (FDU) or Multi Disk Unit (MDU): NT8D68AA, NT8D69AA
- Memory Card: QPC583
- Read Only Memory (ROM) Card: QPC939
- CPU/Network Card Cage Assembly: NT6D3903

Possible cause	Action
Defective UEM power supply	<p>Make sure the green LED on the Common Equipment Power Supply is lit. If it is not lit, go to “Clearing power faults.”</p> <p>If the power supply LED is lit, go to the next possible cause.</p>
Initialization required	<p>Press the manual initialize (MAN INT) button on the Interface Card. If the system initializes, clear any faults indicated.</p> <p>If the system does not initialize, unseat network cards one-at-a-time. If the system initializes, replace the last card you removed (it is faulty).</p> <p>If the system will not initialize, go to the next possible cause.</p>
Defective mass storage unit or interface	<p>Unseat the mass storage unit and interface then reinstall them. Make sure the cable between the interface and the unit is securely connected. If the system does not recover, continue with this procedure.</p> <p>If a disabled FDI or MSI is indicated</p> <ul style="list-style-type: none"> — make sure the Data Cartridge is securely attached — check the switch settings; if necessary, correct the switch settings — try to enable the interface (try to software disable, hardware disable, then reenable) — if you cannot load a program or the interface is still disabled, replace it — if necessary, replace the Data Cartridge <p>If a disabled FDU or MDU is indicated</p> <ul style="list-style-type: none"> — replace it — if the unit is still disabled, replace the cable between the unit and the interface <p>If the system does not recover, go to the next possible cause.</p>
Sysload required	<p>Press the reload (RLD) button on the CMA Card.</p> <p>If a sysload (reload) occurs, clear any faults indicated.</p> <p>If the system will not sysload, go to the next possible cause,</p>

Defective CE
card

Unseat the CE cards then reinstall them. If the system does not recover, continue with this procedure. Try to sysload after any card is replaced.

Make sure the cable between the Interface and Function cards is securely connected. Make sure the CMA cable is securely connected.

Check the CPU cards

- make sure the ROM Card is properly installed on the Function Card
- as necessary, replace the Interface Card, the Function Card, the ROM Card, and the cable

If the system does not sysload, replace the Memory Card.

If the system does not sysload, replace the CMA Card. If necessary, replace the CMA cable.

If the system does not sysload, replace the BTU.

If the system does not recover, go to the next possible cause.

Defective
backplane

Replace the card cage assembly in the UEM.

Symptom:
Fault indicated on Memory Card (system option 51)

The red LED is lit on the Memory Card and call processing has stopped. Look up all system messages and maintenance display codes in the *X11 input/output guide* (553-3001-400) and follow the instructions given. If the fault does not clear, use **this** procedure.

Note: Be sure to take any action indicated by the maintenance display codes. Constantly observe and look up system messages as you perform this procedure.

Replace equipment as described in **Hardware replacement (553-300 I-520)**. You may need to replace:

- Changeover and Memory Arbitrator (CMA) Card: QPC58 1
- CPU Function (FN) Card: QPC579
- CPU Interface (IF) Card: QPC580
- Memory Card: QPC583
- Read Only Memory (ROM) Card: QPC939
- CPU/Network Card Cage Assembly: NT6D3903

Possible cause	Action
Defective Memory Card	<p>Unseat the card then reinstall it.</p> <p>If the LED on the card is still lit, replace the card.</p> <p>If the LED turns off but the system does not recover, go to the next possible cause.</p>
Defective CE card	<p>Unseat the CE cards then reinstall them. If the system does not recover, continue with this procedure.</p> <p>Make sure the cable between the Interface and Function cards is securely connected. Make sure the CMA cable is securely connected.</p> <p>Check the CPU cards</p> <ul style="list-style-type: none"> — make sure the ROM Card is properly installed on the Function Card — as necessary, replace the Interface Card, the Function Card, the ROM Card, and the cable

If the system does not recover, replace the CMA Card. If necessary, replace the CMA cable.

If the system does not recover, go to the next possible cause.



Defective
backplane

Replace the card cage assembly in the **UEM**.

Symptom: Fault indicated on a Common Equipment card (system option 51)

The red LED is lit on a Common Equipment card, other than the Memory Card. Look up all system messages and maintenance display codes in the X11 **input/output guide** (553-3001-400) and follow the instructions given. If the fault does not clear, use this procedure.

Note: Make sure the normal/maintenance switch on the QPC580 CPU Interface Card is set to MAINT. Constantly observe and look up system messages as you perform this procedure.

For information on switch settings, **see Circuit pack installation and testing** (553-3001-211). Replace equipment **as** described **in Hardware replacement** (553-3001-520). You may need to replace:

- Changeover and Memory Arbitrator (CMA) Card: QPC58 1
- CPU Function (FN) Card: QPC579
- CPU Interface (IF) Card: QPC580
- Floppy Disk Interface (FDI) Card or Mass Storage Interface (MSI) Card: QPC742, QPC584
- Memory Card: QPC583
- Read Only Memory (ROM) Card: QPC939
- Serial Data Interface (SDI) Cards: NT8D4 1 AA, QPC5 13, QPC84 1
- CPU/Network Card Cage Assembly: NT6D3903

Possible cause	Action
Defective FDI or MSI (lit LED)	<p>Unseat the card then reinstall it. If the card does not recover</p> <ul style="list-style-type: none"> — make sure the cable between the mass storage unit and the interface is securely connected — check the switch settings; if necessary, correct the switch settings and try to enable — if you cannot load a program or the card will not enable, replace the card <p>If the CPU is still faulty, go to the next possible cause.</p>

Defective **SDI**

Check each **SDI** port by entering

LD 37

TTY x

("x" represents the number of the interface device attached to the port)

- if software is disabled, try to enable it (**software-disable**, hardware disable, then try to reenabte)
- if the card will not enable, replace it

If the CPU is still faulty, go to the next possible cause.

Defective CE card (lit LED)

Unseat the CE cards then reinstall them. If all cards do not recover, continue with this procedure.

If the LED is lit on the Interface Card

- make sure the cable between the Interface and Function cards is securely connected
- make sure **the** ROM Card is properly installed on the Function Card
- as necessary, replace the Interface Card, the Function Card, the ROM Card, and the cable

If the LED is lit on the CMA, make sure the CMA cable is securely connected. If the cable is connected, enter

LD 35

STAT CMA x

("x" represents the CMA number)

- if the CMA is disabled, try to enable it (software disable, hardware disable, then try to reenabte)
- if the card will not enable, replace it
- if the replacement CMA does not enable, replace the cable

If the LED is lit on the Memory Card, enter

LD 35

MEM x

("x" represents a two-digit number-the first digit is the CPU Interface Card and the second is the Memory Card number)

- if the card is disabled, try to enable it (software disable, then reenabte)
- if the card will not enable, replace it

If the CPU is still faulty, go to the next possible cause.

Defective backplane

Replace the card cage assembly in the UEM.

Symptom: Call processing stopped (system options 61 and 71)

Call processing has stopped on a dual CPU system. Look up all system messages and maintenance display codes in **the XIJ input/output guide** (553-3001-400) and follow the instructions given. If the fault does not clear, use this procedure. Before you begin:

- Make sure the normal/maintenance switch on both QPC580 CPU Interface Cards is set to NORM.
- Be sure to take any action indicated by the maintenance display codes.

Note: Constantly observe and look up codes and system messages as you perform this procedure.

For information on switch settings, **see Circuit pack installation and testing** (553-3001-211). Replace equipment as described in **Hardware replacement** (553-3001-520). You may need to replace:

- Bus Terminating Unit (BTU): QPC477
- Changeover and Memory Arbitrator (CMA) Card: QPC581
- CPU Function (FN) Card: QPC579
- CPU Interface (IF) Card: QPC580
- Data Cartridge: QMM42
- Floppy Disk Interface (FDI) Card or Mass Storage Interface (MSI) Card: **QPC584** and QPC742
- Floppy Disk Unit (FDU) or Multi Disk Unit (MDU): NT8D68AA, NT8D69AA
- Memory Card: QPC583
- Read Only Memory (ROM) Card QPC939
- Segmented Bus Extender (SBE) Card: QPC215 (system option 71)
- Three-Port Extender (3PE) Card: QPC441
- CPU/Network or CPU Card Cage Assembly: NT6D3903, NT8D3403

Possible cause	Action
Defective UEM power supply	<p>Make sure the green LED on the Common Equipment Power Supply is lit. If it is not lit, go to "Clearing power equipment faults."</p> <p>If the power supply LED is lit, go to the next possible cause.</p>
Initialization required	<p>Press the manual initialize (MAN INT) button on the Interface Card on the inactive CPU. If the system initializes, clear any faults indicated.</p> <p>If the system does not initialize, unseat network cards one-at-a-time. If the system initializes, replace the last card you removed (it is faulty).</p> <p>If the system will not initialize, go to the next possible cause.</p>
Defective mass storage unit or interface	<p>Unseat the mass storage unit and the interface on the inactive CPU then reinstall them. Make sure the cable between the interface and the unit is securely connected. If the system does not recover, continue with this procedure.</p> <p>If a disabled interface is indicated</p> <ul style="list-style-type: none"> — make sure the Data Cartridge is securely attached — check the switch settings; if necessary, correct the switch settings — try to enable the interface (try to software disable, hardware disable, then reenable) — if you cannot load a program or the interface is still disabled, replace it — if necessary, replace the Data Cartridge <p>If a disabled mass storage unit is indicated</p> <ul style="list-style-type: none"> — replace it — if the unit is still disabled, replace the cable between the unit and the interface <p>If the system does not recover go to the next possible cause.</p>
Sysload required	<p>Simultaneously press the reload (RLD) button on both CMA cards.</p> <p>If a sysload (reload) occurs, clear any faults indicated.</p> <p>If the system will not sysload, go to the next possible cause.</p>

-continued —

Possible cause	Action
Defective CE card	<p>Unseat the CE cards then reinstall them.</p> <ul style="list-style-type: none"> — make sure all CE cables are securely connected, including the cable between the Interface and Function Cards. — make sure the ROM Card is properly installed on the Function Card <p>If the system does not recover, continue with this procedure. Try to sysload after any card is replaced.</p> <p>Check the inactive CPU by entering LD 35 TCPU</p> <ul style="list-style-type: none"> — if a disabled card is indicated, check it with the appropriate test or stat command — try to software enable any disabled card (software disable, hardware disable, then reenable) <p>If the system does not recover</p> <ul style="list-style-type: none"> — unseat all CE cards (including extenders) on the inactive CPU; try to sysload by pressing the reload button on the one inserted CMA — if a sysload occurs, reinsert the cards one-at-a-time; the system will fail when the defective card is inserted; replace that card <p>If the system does not sysload when all cards are reinstalled on the inactive CPU</p> <ul style="list-style-type: none"> — remove the cards from the other CPU and try to sysload — again, if a sysload occurs, reinsert the cards one-at-a-time; replace the card that causes the failure <p>If the system still does not sysload, one-at-a-time, replace the Common Equipment cables until a sysload occurs.</p> <p>If the system does not recover, go to the next possible cause.</p>
Defective backplane	<p>Replace the card cage assembly in the UEM.</p>

Symptom: Fault indicated on a Memory Card (system options 61 and 71)

The red LED is lit on a Memory Card. The dual CPU system will be operating but may be limited to one CPU. Look up all system messages and maintenance display **codes** in the *X11 input/output guide* (553-3001-400) and follow the instructions given. If the fault does not clear, use this procedure.

Replace equipment **as** described in **Hardware replacement** (553-3001-520). You may need to replace:

- Changeover and Memory Arbitrator (CMA) Card: QPC581
- CPU Function (FN) Card: QPC579
- CPU Interface (IF) Card: QPC580
- Memory Card: QPC583
- Read Only Memory (ROM) Card: QPC939
- CPU/Network or CPU Card Cage Assembly: NT6D3903, NT8D3403

Possible cause	Action
Defective Memory Card	<p>Check disabled memory by entering LD 35 LDIS (If the disabled Memory Card is on the active CPU, switch CPUs by entering SCPU.)</p> <p>Test the disabled Memory by entering MEM x ("x" represents the Memory Card number)</p> <p>If the Memory Card fails the test, replace it.</p> <p>If the Memory Card passes the test, software disable it, then try to reenable by entering ENL x If the card will not enable, replace it.</p> <p>If all Memory Cards are enabled but the CPU is still faulty, go to the next possible cause.</p>

-continued —

Possible cause	Action
Defective CMA	<p>Make sure the cable between the CMA Cards is securely connected.</p> <p>Check the status of the CMA on the inactive CPU by entering STAT CMA x ("x" represents the CMA number)</p> <p>If the CMA is enabled, try to switch CPUs by entering SCPU</p> <p>If the CPU cannot switch but additional system messages do not indicate a CMA problem, go to the next possible cause.</p> <p>If the CMA is disabled or additional system messages indicate a CMA problem, try to enable the CMA by entering ENL CMA x</p> <p>If the card will not enable, replace it.</p> <p>If the CMA is enabled but the CPU still will not switch, go to the next possible cause.</p>
Defective CE card	<p>Unseat the CE cards on the inactive CPU then reinstall them.</p> <ul style="list-style-type: none"> — make sure all CE cables are securely connected, including the cable between the Interface and Function Cards — make sure the ROM Card is properly installed <p>If the CPU is still faulty, continue with this procedure.</p> <p>Check the inactive CPU by entering LD 35 TCPU</p> <ul style="list-style-type: none"> — if a disabled card is indicated, check it with the appropriate test or stat command — try to software enable any disabled card (software disable, hardware disable, then reenable) <p>If the CPU is still faulty</p> <ul style="list-style-type: none"> — unseat all CE cards on the inactive CPU; try to sysload by pressing the reload button on the single inserted CMA — if a sysload occurs, reinsert the cards one-at-a-time; the system will fail when the defective card is inserted; replace that card

If the CPU is still-faulty, one-at-a-time, replace the Common Equipment cables until a sysload occurs.

If the CPU is still faulty, go to the next possible cause.

**Defective
backplane**

Replace the card cage assembly in the UEM.

Symptom: Fault indicated on a Common Equipment card (system options 61 and 71)

The red LED is lit on a Common Equipment card, other than a Memory Card. The dual CPU system will still be operating but may be limited to one CPU. Look up all system messages and maintenance display codes in the XII *input/output guide* (553-3001-400) and follow the instructions given. If the fault does not clear, use **this** procedure.

Note: Make sure the normal/maintenance switch on both QPC580 CPU Interface Cards is set to NORM. Constantly observe and look up system messages as you perform this procedure.

For information on switch settings, *see Circuit pack installation and testing* (553-3001-211). Replace equipment *as* described *in Hardware replacement* (553-3001-520). You may need to replace:

- Bus Terminating Unit: QPC477
- Changeover and Memory Arbitrator (CMA) Card: QPC581
- CPU Function (FN) Card: QPC579
- CPU Interface (IF) Card: QPC580
- Floppy Disk Interface (FDI) Card: QPC742
- Mass Storage Interface (MSI) Card: QPC584
- Memory Card: QPC583
- Read Only Memory (ROM) Card: QPC939
- Segmented Bus Extender (SBE) Card: QPC215 (system option 71)
- Serial Data Interface (SDI) Cards: NT8D41AA, QPC513, QPC841
- Three-Port Extender (3PE) Card: QPC441
- CPU/Network or CPU Card Cage Assembly: NT6D3903, NT8D3403

Possible cause	Action
Defective FDI or MSI (lit LED)	<p>Unseat the FDI or MSI then reinstall it. If the card does not recover, continue with this procedure.</p> <p>Make sure the cable between the mass storage unit and the interface is securely connected.</p> <p>Check the card by entering LD 37 MSI x ("x" represents the FDI or MSI number)</p> <ul style="list-style-type: none"> — if the card is disabled, try to enable it (software disable, hardware disable, then try to reenable) — if the card will not enable, check switch settings; if necessary, correct the switch settings and try to enable — if the card will not enable, replace the card <p>If the CPU is still faulty, go to the next possible cause.</p>
Defective SDI	<p>Check each SDI port by entering LD 37 TTY x ("x" represents the number of the interface device attached to the port)</p> <ul style="list-style-type: none"> — if software is disabled, try to enable it (software disable, hardware disable, then try to reenable) — if the card will not enable, replace it <p>If the CPU is still faulty, go to the next possible cause.</p>

-continued —

Possible cause	Action
Defective CE card (lit LED)	<p>Unseat the cards then reinstall them. Make sure all cables are securely connected. If all cards do not recover, continue with this procedure.</p> <p>If the LED is lit on the Interface Card</p> <ul style="list-style-type: none"> — make sure the cable between the Interface and Function cards is securely connected — make sure the ROM Card is properly installed on the Function Card — as necessary, replace the Interface Card, the Function Card, the ROM Card, and the cable <p>If the LED is lit on some other Common Equipment card, enter LD 35 and the appropriate test or stat command to check the status of the card</p> <ul style="list-style-type: none"> — if a card is disabled, try to enable it (software disable, hardware disable, then try to reenable) — if the card will not enable, replace it — if the card enables and the LED turns off, test the CPU by entering: LD 35 TCPU <p>If the CPU is still faulty, one-at-a-time replace the Common Equipment cards until the fault clears.</p> <p>If the CPU is still faulty, one-at-a-time replace the Common Equipment cables.</p> <p>If the CPU remains faulty, go to the next possible cause.</p>
Defective backplane	<p>Replace the card cage assembly in the UEM.</p>

Symptom: Floppy Disk Unit not operating

There may be a lit LED on the Floppy Disk Unit (FDU). There may be a maintenance display code on the Floppy Disk Interface (FDI) Card indicating a problem with the FDU. Look up all system messages and maintenance display **codes in the XII input/output guide** (553-3001-400) and follow the instructions given. If the fault does not clear, use this procedure.

Note: Be sure to take any action indicated by the maintenance display codes. Constantly observe and look up system messages as you perform this procedure.

For information on switch settings, **see Circuit pack installation and testing** (553-3001-211). Replace equipment **as** described in **Hardware replacement** (553-3001-520). You may need to replace:

- Cable between Floppy Disk Unit and Floppy Disk Interface
- Data Cartridge: QMM42
- Floppy Disk Interface (FDI) Card: QPC742
- Floppy Disk Unit (FDU): NT8D68AA

Possible cause	Action
Defective FDI or Data Cartridge	<p>Unseat the FDU and FDI then reinstall them. Make sure the cable between the FDU and FDI is securely connected. (In a dual CPU system, check both FDIs.) If the FDU does not recover, continue with this procedure.</p> <p>Check the FDI</p> <ul style="list-style-type: none"> — make sure the Data Cartridge is securely attached — check switch settings; if necessary, correct the switch settings — try to enable the FDI (try to software disable, hardware disable, then reenable) — if you cannot load a program or the FDI is still disabled, replace it — if necessary, replace the Data Cartridge <p>If the FDU is still not operating, go to the next possible cause.</p>
Defective FDU or cable	<p>Replace the FDU. If it is still disabled, replace the cable between the FDU and FDI.</p>

Symptom: Multi Disk Unit not operating

There may or may not be a lit LED on the front of the Multi Disk Unit (MDU). There may be a maintenance display code on the Mass Storage Interface (MSI) Card indicating a problem with the MDU. Look up all system messages and maintenance display codes in the ***XII input/output guide (553-3001-400)*** and follow the instructions given. If the fault does not clear, use this procedure.

Note: Be sure to take any action indicated by the maintenance display codes. Constantly observe and look up system messages as you perform this procedure.

For information on switch settings, see ***Circuit puck installation and testing (553-3001-211)***. Replace equipment **as** described in ***Hardware replacement (553-3001-520)***. You may need to replace:

- Cable between Multi Disk Unit and Mass Storage Interface
- Data Cartridge: **QMM42**
- Mass Storage Interface (MSI) Card: **QPC584**
- Multi Disk Unit (MDU): **NT8D69AA**
- CPU/Network or CPU Card Cage Assembly: **NT6D3903, NT8D3403**

Possible cause	Action
Defective MDU (lit LED)	<p>Unseat the MDU and MSI then reinstall them. Make sure the cable between the MDU and MSI is securely connected. (In a dual CPU system, check both MSIs.) If the MDU does not recover, continue with this procedure.</p> <p>Try to restore the hard drive from the floppy disks</p> <ul style="list-style-type: none"> — hardware disable the MSI (in a dual CPU system, disable both MSIs), remove the card and set SW4 to OFF — reinstall the MSI and hardware enable it — try to software enable the MSI through the Overlay Loader (you will not be in an overlay) by entering **** <p>ENLT</p>

If you cannot load the program, try to enter **LD 37** through the maintenance telephone

- if you can load the program, test the port for the system terminal you were using
- if the port is okay, test the cable to the system terminal
- if the cable is okay, check the **system** terminal

If you cannot load a program through the system terminal or the maintenance telephone, replace the MDU.

If the MDU is still faulty, go to the next possible cause.

Defective cable between MDU and **MSI**

Replace the cable to each **MSI**.

Try to test the **MSI** and MDU by entering

LD 37

MSI x

("x" represents the **MSI** number 0 or 1)

If the MDU is still faulty, go to the next possible cause.

Defective **MSI**

Check the **MSI**

- make sure the Data Cartridge is securely attached
- check switch settings; if necessary, correct the switch settings
- try to enable the **MSI** (try to software disable, hardware disable, then reenable)
- if you cannot load a program or the **MSI** is still disabled, replace it
- if the **MSI** is still disabled, replace the Data Cartridge

If the MDU is still faulty, go to the next possible cause.

Defective backplane connection to MDU (**LED** not lit)

Move the MDU to another acceptable location.

Try to test the MDU by entering

MSI x

If the MDU is still faulty, replace it.

If the MDU enables after it is moved, replace the card cage assembly in the UEM you took it from.



Clearing Network Equipment faults

Chapter contents

Network Equipment faults	75
Fault clearing procedures	76
Symptoms:	
Disabled loop indicated by OVD message (NT8D04AA Superloop Network Card)	78
Loop disabled without OVD message (NT8D04AA Superloop Network Card)	80
Disabled loop indicated by OVD message (QPC414 Network Card)	83
Loop disabled without OVD message (QPC414 Network Card)	86
Disabled Peripheral Signaling Card indicated by OVD message	89
Peripheral Signaling Card disabled without OVD message	91
Problems with transferring, placing conference calls, or Music-on-Hold	93
Problems placing calls on 2500-type telephone sets and some trunks	95

Network Equipment faults

Network Equipment in the SL-1 provides speech path switching and transmits and receives signaling messages from the CPU. Network Equipment can include:

- Conference: provides conference capability for the system

- **Conference/Tone** and Digit Switch: combines the functionality of Conference, Tone and Digit Switch, and Multi-Frequency Sender
- **InterGroup** Switch: provides speech path switching between network groups for system option 71
- Network Card: provides the digital switching for the system
- **Network/Digitone** Receiver: provides digital switching for the system and converts multifrequency dialing signals
- Peripheral Signaling: provides the signaling interface to the CPU in all systems and clocking for system option 5 1
- Superloop Network Card: provides the digital switching for the system at the Superloop level.
- Tone and Digit Switch: provides all tones for the system
- Serial Data Interface: provides the interface from the CPU to an Input/Output (I/O) device
- Three-Port Extender: provides the control interface between Network Equipment cards

Network Equipment faults can cause system initializations and disable conference capability or all terminal connections (such as trunks and telephone sets) on a loop. Defective Network Equipment can make functional Peripheral Equipment seem faulty.

Fault clearing procedures

Manual Continuity Tests can be used to isolate Superloop Network Card and Intelligent Peripheral Equipment faults. For a description of Manual Continuity Tests, *see General maintenance information* (553-3001-500). *See "LD45" the XII input/output guide* (553-3001-400) for details on performing the tests.

Table 10 lists common Network Equipment fault indications. To clear faults, select the symptom in "Chapter contents" that most resembles the fault indications and go through the procedure for clearing each possible cause until the fault is fixed. Once the fault is corrected, disregard the remaining possible causes.

Note: Clear any power or Conimon Equipment faults before you try to clear Network Equipment faults.

If the fault is not cleared after you have gone through each possible cause, check the most recent fault indications. Also check “Hqw to clear faults” to see if another type of fault is indicated.

After the fault is corrected, go to “Final maintenance procedure” to completely restore normal operation.

WARNING

UEM covers are not hinged; do *not* let go of the cover. Lift the cover away from the UEM and set it out of your work area.

Table 10
Network Equipment fault indicators

Indicator	Possible indications
System messages	<ul style="list-style-type: none"> • BSD081, 101, 110, 111, 121, 130, 201—203, 205—209, 600, 602 • CNF messages • DTA, DTC, DTI messages • ERR020, 120, 4060 • INI003, 008—012 • NWS101, 141, 201—204, 301, 401 • OVD021, 022, 023, 031 • TDS messages • XMI messages
Visual indicators	<ul style="list-style-type: none"> • Minor alarm on an attendant console • Red LEDs lit or flashing on cards
User reports	<ul style="list-style-type: none"> • Minor alarm reported by attendant • Users cannot transfer or conference • Users cannot dial out on 500/2500-type telephone sets • No dial tone at ail sets; no display on digital sets

Symptom: Disabled loop indicated by OVD message (NT8D04AA Superloop Network Card)

An overload (OVD) system message indicates a loop on an NT8D04AA Superloop Network Card is disabled. All terminal connections on the loop are disabled. A red LED on the **card** may be lit or flashing. Look up all system messages and maintenance display codes in the *X11 input/output guide* (553-3001-400) and follow the instructions given. If the fault does not clear, use this procedure.

Manual Continuity Tests can be used to isolate Superloop Network Card and Intelligent Peripheral Equipment faults. See “LD45” the *X11 input/output guide* (553-3001-400) for details on performing the tests.

Note: Constantly observe and look up system messages as you perform this procedure.

Replace equipment as described in *Hardware replacement* (553-3001-520). You may need to replace:

- Controller Card: NT8D01AC, NT8D01AD
- Superloop Network Card: NT8D04AA
- Some Peripheral Equipment (PE) card
- Cable between Superloop Network Card and Controller Card

Possible cause	Action
Defective Superloop Network Card	<p>Hardware disable then reenable the Superloop Network Card to initiate a self-test. If the test fails, replace the card. If the test passes, follow the procedure below.</p> <p>Disconnect the loop cable(s) to the Superloop Network Card. Enable and test each loop on the card by entering</p> <p>LD 30 ENLL loop ("loop" represents the loop number)</p> <p>Wait for an OVD message.</p>

**Defective
Controller Card**

If you receive an OVD message, replace the Superloop Network Card.

If there is no OVD message, go to the next possible cause.

Unseat all cards on the PE shelf except the Controller Card. Reconnect the loop cable to the Controller Card and enable the card by entering

LD32

ENXP x

("x" represents the controller number)

Note: If there are multiple shelves involved, follow this and subsequent procedures one-at-a-time for each Controller Card.

Check the maintenance display codes on the Controller Card and wait for an OVD message.

If you receive an OVD message, unseat and reinstall the Controller Card to initiate a self-test. If the test fails, replace the card and reinsert cards on the PE shelf.

If there is no OVD message, go to the next possible cause.

**Defective PE
card**

Reinsert the PE cards one-at-a-time. Wait for an OVD message after each card is inserted.

If the red LED lights when a card is inserted, software disable the card, then try to reenable it. If it will not enable, replace the card.

If you receive an OVD message when one of the PE cards is inserted, replace that card.

If there is no OVD message as you insert the cards, go to the next possible cause.

Defective cable

Disconnect the loop cable at the Controller Card. (If there are multiple loop cables, disconnect them one-at-a-time and follow the procedure below for each cable.)

Reconnect the cable(s) to the Superloop Network Card and wait for an OVD message.

If you receive an OVD message, replace the cable.

If there is no OVD message, go to the next possible cause.

**Defective
terminal
equipment**

Check terminal equipment (such as attendant consoles and telephone sets) on the disabled loop.

If you find defective terminal equipment, see the appropriate chapter (such as "Clearing attendant console faults") to fix the fault.

Symptom: Loop disabled without OVD message (NT8D04AA Sup&loop Network Card)

There is probably a system message indicating the loop or loops on this card are defective or disabled, but there is no overload (OVD) message indicating the card is disabled. The LED on the faceplate may be lit or flashing. Look up all system messages and maintenance display codes in *the XII input/output guide* (553-3001-400) and follow the instructions given. If the fault does not clear, use this procedure.

Manual Continuity Tests can be used to isolate Superloop Network Card and Intelligent Peripheral Equipment faults. See “LD45” the *XI 1 input/output guide* (553-3001-400) for details on performing the tests.

Note: Constantly observe and look up system messages as you perform this procedure.

Replace equipment as described in *Hardware replacement* (553-3001-520). You may need to replace:

- Controller Card: NT8D01AC, NT8D01AD
- Superloop Network Card: NT8D04AA
- Some Peripheral Equipment (PE) card
- Cable between Superloop Network Card and Controller Card

Possible cause	Action
Defective Superloop Network Card	<p>Hardware disable then reenable the Superloop Network Card to initiate a self-test. If the test fails, replace the card. If the test passes, follow the procedure below.</p> <p>Disconnect the loop cable(s) to the Superloop Network Card. Enable and test each loop on the card by entering</p> <p>LD 30 ENLL loop (“loop” represents the loop number)</p> <p>Try to enable the loops by entering</p> <p>ENLL 1</p>

If you receive an OVD message at this point, replace the Superloop Network Card.

If there is no OVD message and the loops will not enable, go to the next possible cause.

Defective
Controller Card

Unseat all cards on the PE shelf except the Controller Card. Reconnect the loop cable to the Controller Card and enable the Controller Card by entering

LD32

ENXP x

("x" represents the controller number)

Note: If there are multiple shelves involved, follow this and subsequent procedures one-at-a-time for each Controller Card.

Check the maintenance display codes on the Controller Card.

If you receive an OVD message at this point, unseat and reinstall the Controller Card to initiate a self-test. If the test fails, replace the card. Reinsert cards on the PE shelf.

If there is no OVD message and the loops will not enable, go to the next possible cause.

Defective PE
card

Reinsert the PE cards one-at-a-time.

If the red LED lights when a card is inserted, software disable the card, then try to reenale it. If it will not enable, replace the card.

If you receive an OVD message when one of the PE cards is inserted, replace that card.

If no LEDs light and there is no OVD message as you reinsert the cards, go to the next possible cause.

-continued -

Possible cause	Action
Defective cable	<p>Disconnect the loop cable at the Controller Card. (If there are multiple loop cables, disconnect them one-at-a-time and follow the procedure below for each cable.)</p> <p>Reconnect the cable(s) to the Superloop Network Card.</p> <p>If you receive an OVD message at this point replace the cable.</p> <p>If there is no OVD message and the loops will not enable, go to the next possible cause.</p>
Defective terminal equipment	<p>Check terminal equipment (such as attendant consoles and telephone sets) on the disabled loop.</p> <p>If you find defective terminal equipment, see the appropriate chapter (such as “Clearing attendant console faults”) to fix the fault.</p>



Symptom: Disabled loop indicated by OVD message (QPC414 Network Card)

An overload (OVD) system message indicates a loop on a QPC414 Network Card is disabled. All terminal connections on the loop are disabled. A red LED on the card may be lit. Look up all system messages and maintenance display codes in the *XII input/output guide* (553-3001-400) and follow the instructions given. If the fault does not clear, use this procedure.

Note: Constantly observe and look up system messages as you perform this procedure.

For information on switch settings, see *Circuit pack installation and testing* (553-3001-211). Replace equipment as described in *Hardware replacement* (553-3001-520). You may need to replace:

- Dual Loop Peripheral Buffer Card (DLB): QPC659
- Network Card: QPC414
- Some Peripheral Equipment (PE) card
- Cable between Network Card and Dual Loop Peripheral Buffer Card

Possible cause	Action
Defective Network Card	<p>Disconnect the loop cable(s) to the Network Card. Enable and test each loop on the Network Card by entering LD 30 ENLL loop (“loop” represents the loop number)</p> <p>Wait for an OVD message.</p> <p>If you receive an OVD message, replace the Network Card.</p> <p>If there is no OVD message, go to the next possible cause.</p>
Defective Peripheral Buffer Card	<p>Unseat all cards on the PE shelf except the Peripheral Buffer Card (if there are two shelves on the loop, disconnect the cable to connector LPY)</p> <ul style="list-style-type: none"> — reconnect the loop cable to the Peripheral Buffer Card — if you receive an OVD message, replace the Peripheral Buffer Card and reinsert cards on the PE shelf

-continued -

Possible cause	Action
Defective Peripheral Buffer Card on second shelf (if two shelves on the loop)	<p>If there is no OVD message</p> <ul style="list-style-type: none"> — check switch settings-on the Peripheral Buffer Card; if necessary, correct the switch settings — if there are two shelves on the loop, go to the next possible cause — if there is one shelf on the loop, go to “Defective PE card” <p>Unseat all cards on the second shelf except the Peripheral Buffer Card. Reconnect the inter-shelf cable to the Peripheral Buffer Card and wait for an OVD message.</p> <p>If there is an OVD message, replace the Peripheral Buffer Card and reinsert cards on the PE shelf.</p> <p>If there is no OVD message, go to the next possible cause.</p>
Defective PE card	<p>Reinsert the PE cards one-at-a-time. (If there are two shelves on the loop, follow this and subsequent procedures one-at-a-time for each shelf.) Wait for an OVD message after each card is inserted.</p> <p>If the LED lights when a card is inserted, software disable the card, then try to reenable it. If it will not enable, replace the card.</p> <p>If you receive an OVD message when one of the PE cards is inserted replace that card.</p> <p>If there is no OVD message as you reinsert the cards, go to the next possible cause.</p>
Defective cable between Network and Peripheral Buffer Cards	<p>Disconnect the loop cable at the Peripheral Buffer Card. Reconnect the cable(s) to the Network Card and wait for an OVD message.</p> <p>If you receive an OVD message, replace the cable.</p> <p>If there is no OVD message, go to the next possible cause.</p>

Defective cable
between shelves

(if **two shelves on**
the loop)

Disconnect the inter-shelf cable to connector LPX on the second shelf Peripheral Buffer Card.

Reconnect the cable to connector LPY on the first shelf Peripheral Buffer Card and wait for an OVD message.

If you receive an OVD message, replace-the inter-shelf cable. Reinsert cards on **the** PE shelf.

If there is no OVD message, go to the next possible cause.

Defective
terminal
equipment

Check terminal equipment (such as attendant consoles and telephone sets) on the disabled loop.

If you find defective terminal equipment, see the appropriate chapter (such as “Clearing attendant console faults”) to fix the fault.

Symptom: Loop disabled without OVD message (QPC414 Network Card)

There is probably a system message indicating the loop or loops on this card are defective or disabled, but there is no overload (OVD) message indicating the card is disabled. The LED on the faceplate may be lit. Look up all system messages and maintenance display codes in the XII **input/output guide** (553-3001-400) and follow the instructions given. If the fault does not clear, use this procedure.

Note: Constantly observe and look up system messages as you perform this procedure.

For information on switch settings, **see Circuit pack installation and testing** (553-3001-211). Replace equipment **as** described in **Hardware replacement** (553-3001-520). You may need to replace:

- Dual Loop Peripheral Buffer Card (DLB): QPC659
- Network Card: QPC414
- Some Peripheral Equipment (PE) card
- Cable between Network Card and Dual Loop Peripheral Buffer Card

Possible cause	Action
Defective Network Card	<p>Test the loops on the card by entering LD 30 LOOP loop ("loop" represents the loop number)</p> <p>Try to enable the loops by entering ENLL 1</p> <p>Wait for an OVD message.</p> <p>If you receive an OVD message at this point, replace the Network Card.</p> <p>If there is no OVD message and the loops will not enable, go to the next possible cause.</p>

<p>Defective Peripheral Buffer Card</p>	<p>Unseat all cards on the PE shelf except the Peripheral Buffer Card (if there are two shelves on the loop, disconnect the cable to connector LPY)</p> <ul style="list-style-type: none"> — reconnect the loop cable to the Peripheral Buffer Card — if you receive an OVD message at this point, replace the Peripheral Buffer Card and reinsert cards on the PE shelf <p>If there is no OVD message and the loops will not enable</p> <ul style="list-style-type: none"> — check switch settings on the Peripheral Buffer Card; if necessary, correct the switch settings — if there are two shelves on the loop, go to the next possible cause — if there is one shelf on the loop, go to “Defective PE card”
<p>Defective Peripheral Buffer Card on second shelf (if two shelves on the loop)</p>	<p>Unseat all cards on the second shelf except the Peripheral Buffer Card. Reconnect the inter-shelf cable to the Peripheral Buffer Card.</p> <p>If you receive an OVD message at this point, replace the Peripheral Buffer Card and reinsert cards on the PE shelf.</p> <p>If there is no OVD message and the loops will not enable, go to the next possible cause.</p>
<p>Defective PE card</p>	<p>Reinsert the PE cards one-at-a-time. (If there are two shelves on the loop, follow this and subsequent procedures one-at-a-time for each shelf.)</p> <p>If the LED lights when a card is inserted, software disable the card, then try to reenable it. If it will not enable, replace the card.</p> <p>If you receive an OVD message when one of the PE cards is inserted, replace that card.</p> <p>If no LEDs light and there is no OVD message as you reinsert the cards, go to the next possible cause.</p>
<p>Defective cable between Network and Peripheral Buffer Cards</p>	<p>Disconnect the loop cable at the Peripheral Buffer Card. Reconnect the cable(s) to the Network Card.</p> <p>If you receive an OVD message at this point, replace the cable.</p> <p>If there is no OVD message and the loops will not enable, go to the next possible cause.</p>

-continued —

Possible cause	Action
Defective cable between shelves (if two shelves on the loop)	Disconnect the inter-shelf cable to connector LPX on the second shelf Peripheral Buffer Card. Reconnect the cable to connector LPY on the first shelf Peripheral Buffer Card. If you receive an OVD message at this point, replace the inter-shelf cable. Reinsert cards on the PE shelf. If there is no OVD message and the loops will not enable, go to the next possible cause.
Defective terminal equipment	Check terminal equipment (such as attendant consoles and telephone sets) on the disabled loop. If you find defective terminal equipment, see the appropriate chapter (such as "Clearing attendant console faults") to fix the fault.

Symptom: Disabled Peripheral Signaling Card indicated by OVD message

There is an overload (OVD) system message indicating a Peripheral Signaling Card is disabled. The LED on the faceplate may be lit. Look up all system messages and maintenance display **codes** in the **XI 1 input/output guide** (553-3001-400) and follow the instructions given. If the fault does not clear, use this procedure.

Note: Constantly observe and look up system messages as you perform this procedure.

Replace equipment as described **in Hardware replacement** (553-3001-520). You may need to replace:

- Superloop Network Card or Network Card (Network Cards):
NT8D04AA, QPC414
- Peripheral Signaling (PS) Card: QPC43
- Clock Controller : QPC471, QPC775

Possible cause	Action
Defective Peripheral Signaling Card	<p>Unseat all Network Cards associated with the Peripheral Signaling Card.</p> <p>Enable the Peripheral Signaling Card by entering LD 32 ENPS x ("x" represents the Peripheral Signaling Card number)</p> <p>Wait for an OVD message.</p> <p>If you receive an OVD message, replace the Peripheral Signaling Card. If there is no OVD message, go to the next possible cause.</p>

-continued —



Possible cause	Action
Defective Network Card	Reinsert Network Cards one-at-a-time. Wait for an OVD message after each card is inserted. If you receive an OVD message when one of the cards is inserted, replace that card. Reenable the Peripheral Signaling Card by entering LD 32 ENPS x If you do not receive an OVD message, go to the next possible cause.
Defective Clock Controller	<i>See Digital Trunk Interface/Computer to PBX Interface — General maintenance</i> (553-281 1-500)



Symptom: Peripheral Signaling Card disabled without OVD message

The Peripheral Signaling Card is disabled on one shelf. The LED on its faceplate may be lit. There is no overload (OVD) message indicating a fault with this card. Look up all system messages and maintenance display codes in *the XII input/output guide* (553-3001-400) and follow the instructions given. If the fault does not clear, use this procedure.

Note: Constantly observe and look up system messages as you perform this procedure.

Replace equipment as described in *Hardware replacement* (553-3001-520). You may need to replace:

- Superloop Network Card or Network Card (Network Cards):
NT8D04AA, QPC4 14
- Peripheral Signaling (PS) Card: QPC43
- Clock Controller : QPC47 1, QPC775

Possible cause	Action
Defective Peripheral Signaling Card	<p>Unseat all Network Cards associated with the Peripheral Signaling Card.</p> <p>Try to enable the Peripheral Signaling Card by entering LD 32 ENPS x ("x" represents the Peripheral Signaling Card number)</p> <p>If you receive an OVD message at this point or if you cannot enable the Peripheral Signaling Card, replace it.</p> <p>If the Peripheral Signaling Card is still disabled, go to the next possible cause.</p>

-continued —

Possible cause	Action
Defective Network Card	Reinsert Network Cards one-at-a-time. If you receive an OVD message when one of the cards is inserted or if the card is disabled, replace that card. Reenable the Peripheral Signaling Card by entering LD 32 ENPS x If the Peripheral Signaling Card is still disabled, go to the next possible cause.
Defective Clock Controller	See <i>Digital Trunk Interface/Computer to PBX Interface --- General maintenance</i> (553-281 1-500)

Symptom: Problems with transferring, placing conference calls, or Music-on-Hold

Several users cannot transfer or place conference calls, or calls do not receive Music-on-Hold. A card that provides conference capability may be disabled. Look up all system messages and maintenance display codes in *the XII input/output guide* (553-3001-400) and follow the instructions given. If the fault does not clear, use this procedure.

Note: Constantly observe and look up system messages as you perform this procedure.

Replace equipment as described in *Hardware replacement* (553-3001-520). You may need to replace:

- Conference/TDS Card: NT8D17AA
- Peripheral Signaling (PS) Card: QPC43
- Three-Port Extender (3PE) Card: QPC44 1
- Telephone set keys

Possible cause	Action
Defective Conference/TDS Card	<p>If there are no messages indicating a fault on any conference loop, test each conference loop in the system by entering LD 38 CNFC loop ("loop" represents the conference loop number)</p> <p>Note: See the <i>X11 input/output guide</i> for other tests.</p> <p>If the conference loop is disabled, try to enable it by entering LD 38 ENLX loop ("loop" represents the Conference loop, which is the odd loop of the Conference/TDS loop pair)</p> <p>Note: You must enable the card with the command ENLX. Enabling the loops with the command ENLL does not enable the hardware.</p>

-continued —



Possible cause	Action
	<p>If a fault is indicated on a conference loop, replace the Conference/TDS Card identified.</p> <p>If no faults are detected on any conference loop, go to the next possible cause.</p>
Defective card on Network shelf	<p>One-at-a-time, replace the following cards until the fault clears</p> <ul style="list-style-type: none"> — Three-Port Extender Card — Peripheral Signaling Card <p>If there is still a Conference problem, go to the next possible cause.</p>
Defective telephone set keys	<p>Check the keys on any telephone set with this problem. See the following Northern Telecom Publications:</p> <ul style="list-style-type: none"> — <i>X11 input/output guide (553-3001-400)</i> — LD 31 tests — <i>Installation procedures for telephone sets and attendant consoles (553-3001-215)</i> — <i>Meridian M2000 Digital Telephones-Description, installation, operation, and maintenance (553-2201-1 10)</i>
Excessive traffic in the system	<p>Additional Conference/TDS Cards may be required to handle the traffic in the system. See <i>Traffic measurement (553-2001-450)</i>.</p>

Symptom: Problems placing calls on 2500-type telephone sets and some trunks

Several users of 2500-type telephone sets report trouble placing calls. Other users may report trouble dialing on certain trunks. A **Digitone** Receiver or a card that provides Tone and Digit Switch capability may be disabled. Look up all system messages and maintenance display codes in the XI *1 input/output guide* (553-3001-400) and follow the instructions given. If the fault does not **clear**, use this procedure.

Note: Constantly observe and look up system messages as you perform this procedure.

Replace equipment as described in **Hardware replacement** (553-3001-520). You may need to replace:

- Conference/TDS Card: NT8D17AA
- Digitone Receiver (DTR) Card: NT8D16AA
- Network/DTR Card: NT8D18AA

Possible cause	Action
Defective Digitone Receiver	<p>Check for disabled Digitone Receiver TNs by entering LD 34 STAT</p> <p>If any are disabled, try to enable them by entering ENLR I s c u ("I s c u" represents loop, shelf, card, and unit number)</p> <p>Test the Digitone Receiver by entering DTR I s c u</p> <p>If the Digitone Receiver fails the test, replace it.</p> <p>If the Digitone Receiver passes the test, go to the next possible cause.</p>

-continued -



Possible cause	Action
Defective Conference/TDS Card	<p>Test Tone and Digit Switch loops by entering LD 34 TDS loop (“loop” represents the loop number)</p> <p>If the conference loop is disabled, try to enable it by entering ENLX loop (“loop” represents the TDS/MFS loop, which is the even loop of the Conference/IDS loop pair)</p> <p>Note: You must enable the card with the command ENLX. Enabling the loops with the command ENLL does not enable the hardware.</p> <p>If a fault is indicated on a conference loop, replace the Conference/TDS Card identified.</p> <p>If no faults are detected on any conference loop, go to the next possible cause.</p>
Excessive traffic in the system	<p>Additional Digitone Receivers or Conference/TDS Cards may be required to handle the traffic in the system. See <i>Traffic measurement (553-2001-450)</i>.</p>



Clearing Peripheral Equipment faults

Chapter contents

Peripheral Equipment faults	98
Fault clearing procedures	98
Symptoms:	
Red LED lit on Controller Card	100
Red LED lit on Dual Loop Peripheral Buffer Card	102
Disabled Peripheral Equipment card	104
More than one Peripheral Equipment card disabled	106

Peripheral Equipment faults

Peripheral Equipment (**PE**) provides the interface between Network Equipment switching and terminal equipment (such as trunks, telephone sets, data sets, and attendant consoles). Peripheral Equipment faults can disable network and terminal equipment.



Fault clearing procedures

Manual Continuity Tests can be used to isolate Super-loop Network Card and Intelligent Peripheral Equipment faults. For a description of Manual Continuity Tests, *see General maintenance information (553-3001-500)*. *See* “LD45” the XII *input/output guide* (553-3001-400) for details on performing the tests.

Table 11 lists common Peripheral Equipment (**PE**) fault indications (many other system messages may be generated). To clear faults, select the symptom in “Chapter contents” that most resembles the fault indications and go through the procedure for clearing each possible cause until the fault is fixed. Once the fault is corrected, disregard the remaining possible causes.

Note: Clear any power or Common Equipment faults before you try to clear telephone set faults.

If the fault is not cleared after you have gone through each possible cause, check the most recent fault indications. Also check “How to clear faults” to see if another type of fault is indicated.

After the fault is corrected, go to “Final maintenance procedure” to completely restore normal operation.



Table 11
Peripheral Equipment fault indicators

indicator	Possible indications
Sample system messages	<ul style="list-style-type: none"> · BSD301, 401, 4 0 2 · ERR4062 · NWS301, 401, 501 · OVD001—010, 024 · XMI messages
Visual indicators	<ul style="list-style-type: none"> · Red LEDs lit on cards
Maintenance displays	<ul style="list-style-type: none"> · NT8D01 AC or NT8D01 AD Controller Card
User reports	<ul style="list-style-type: none"> · Trouble with calls on attendant console · Trouble with calls on 500/2500-type telephone sets • Trouble with calls on SL-1, MI 000, or digital telephone sets

WARNING

UEM covers **are** not hinged; do not let go of the cover. Lift the cover away from the UEM and set it out of your work area.

Symptom: Red LED lit on Controller Card

The red LED is lit on only one Controller Card. Red LEDs on Peripheral (PE) Equipment cards on the same shelf may be lit. Look up all system messages and maintenance display **codes** in the XII **input/output guide** (553-3001-400) and follow the instructions given. If the fault does not clear, use this procedure.

Manual Continuity Tests can be used to isolate Intelligent Peripheral Equipment faults. See “LD45” the **X11 input/output guide** (553-3001-400) for details on performing the tests.

Note: Constantly observe and look up system messages as you perform this procedure.

Replace equipment as described in **Hardware replacement** (553-3001-520). You may need to replace:

- Controller Card NT8D01AC, NT8D01AD
- Some Peripheral Equipment (PE) card
- Intelligent Peripheral Equipment Card Cage Assembly: NT8D3703

Possible cause	Action
Defective Controller Card	<p>Hardware disable then reenable the Controller Card to initiate a self-test.</p> <ul style="list-style-type: none"> — the maintenance display on the card shows the code for each test running (see “HEX” in the X11 input/output guide) — if the tests complete successfully, the display continually flashes — if the card continuously fails a test, the code for that test is steadily displayed <p>If the test fails, replace the card.</p> <p>If the test passes but the card is still disabled, test the loop by entering LD 30 LOOP loop (“loop” represents the loop number)</p> <p>If the test fails, go to the next possible cause.</p>

Defective PE card

Unseat all the cards in the shelf associated with the Controller Card
— if the red LED on the Controller Card turns off, the fault is in one of the unseated cards

— reinsert the cards one-at-a-time

— when the Controller Card LED **turns on** again, replace the last card you inserted

If the red LED on the Controller Card does not turn off when the PE cards are unseated, reinstall the cards and go to the next possible cause.

Defective cable

Test all cables to the Controller Card

If you find a defective cable, replace it.

If there is no problem with the cables, go to the next possible cause.

Defective backplane

Replace the card cage assembly in the **UEM**.

Symptom: Red LED lit on Dual Loop Peripheral Buffer Card

The red LED is lit on only one Dual Loop Peripheral Buffer Card. Red LEDs on Peripheral (PE) Equipment cards on the same shelf may be lit. Look up all system messages and maintenance display codes in the XII **input/output guide (553-3001-400)** and follow the instructions given. If the fault does not clear, use this procedure.

Note: Constantly observe and look up system messages as you perform this procedure.

For information on switch settings, see **Circuit pack installation and testing (553-3001-211)**. Replace equipment **as** described in **Hardware replacement (553-3001-520)**. You may need to replace:

- Dual Loop Peripheral Buffer Card (DLB): QPC659
- Peripheral Equipment Card Cage Assembly: NT8D1303
- Some Peripheral Equipment (PE) card

Possible cause	Action
Defective Peripheral Buffer Card	Test the shelf by entering LD 30 LOOP loop (“1 s” represents loop and shelf number) Note: If two loops are assigned to the shelf, be sure to test both. If a defective Peripheral Buffer Card is indicated, check the switch settings on the card. If the switch settings are correct, replace the card. If the test fails but the Peripheral Buffer Card does not seem to be faulty, go to the next possible cause.

Defective PE
card

Unseat all the cards in the shelf **associated** with the Peripheral Buffer Card

- if the red LED on the Peripheral Buffer turns off, the fault is in one of the unseated cards
- reinsert the cards one-at-a-time
- when the Peripheral Buffer LED turns on again, replace the last card you inserted

If the red LED on **the** Peripheral Buffer does not turn off when the PE cards are unseated, reinstall the cards and go to the next possible cause.

Defective cable

Test all cables to **the** Peripheral Buffer Card.

If you find a defective cable, replace it.

If there is no problem with the cables, go to the next possible cause.

Defective
backplane

Replace the card cage assembly in the UEM.

Symptom: Disabled Peripheral Equipment card

One Peripheral Equipment (PE) card is disabled, the red LED on a PE card is lit, or two or more units on a card are disabled. **There** is a system message indicating the card or units on the card are disabled. Only **one** card on the shelf is affected. Look up all system messages and **maintenance** display codes in the XII **input/output guide (553-3001-400)** and follow the instructions given. If the fault does not clear, use this procedure.

Manual Continuity Tests can be used to isolate Intelligent Peripheral Equipment faults. **See "LD45" the XII input/output guide (553-3001-400)** for details on performing the tests.

Note.: Constantly observe and look up system messages as you perform this procedure.

Replace equipment as described in **Hardware replacement (553-3001-520)**. You may need to replace:

- Controller Card: NT8D01AC, NT8D01AD
- Dual Loop Peripheral Buffer Card (DLB): QPC659
- Superloop Network Card and Network Card (Network Cards):
NT8D04AA, QPC4 14
- Some Peripheral Equipment (PE) card
- Peripheral Equipment or Intelligent Peripheral Equipment Card Cage Assembly: NT8D1303, NT8D3703

Possible cause	Action
Defective PE card	Replace the affected card. Enable the card by entering LD 32 ENLC 1 s c ("1 s c" represents loop, shelf, and card number) Test the card by entering LD 30 SHLF 1 s

Defective
Controller Card
or Peripheral
Buffer Card

Replace the Controller Card or **Peripheral** Buffer Card.

Enable the PE card by entering
LD 32

ENLC1sc

Test the card by entering

LD 30

SHLF 1 s

Defective
Network Card

Replace the Network Card.

Test the loop by entering

LD 30

LOOP 1

Defective
backplane

Replace the card cage assembly in the UEM.

Symptom: More than one Peripheral Equipment card disabled

More than one Peripheral Equipment card, or two or more units on different cards, are disabled on the same shelf. There is a system message indicating the cards or units on the cards are disabled. Look up all system messages and maintenance display codes in the *X11 input/output guide* (553-3001-400) and follow the instructions given. If the fault does not clear, use this procedure.

Manual Continuity Tests can be used to isolate Intelligent Peripheral Equipment faults. See “LD45” the X11 *input/output guide* (553-3001-400) for details on performing the tests.

Note: Constantly observe and look up system messages as you perform this procedure.

Replace equipment as described *in Hardware replacement (553-3001-520)*. You may need to replace:

- Cable between Network Card and PE shelf
- Controller Card: **NT8D01AC, NT8D01AD**
- Dual Loop Peripheral Buffer Card (DLB): QPC659
- Superloop Network Card and Network Card (Network Cards):
NT8D04AA, QPC4 14
- Some Peripheral Equipment (**PE**) card
- Peripheral Equipment or Intelligent Peripheral Equipment Card Cage Assembly: **NT8D1303, NT8D3703**

Possible cause	Action
Defective Controller Card or Peripheral Buffer Card	Replace the Controller Card or Peripheral Buffer Card. Enable the PE card by entering LD 32 ENLC 1 s c ("1 s c" represents loop, shelf, and card number) Test the card by entering LD 30 SHLF 1 s

Defective cable from Network Card	Disable the loop for the affected shelf by entering LD 32 DISL1 Replace the cable from the Network Card to the PE shelf. Test the loop by entering LD 30 LOOP I
Defective Network Card	Replace the Network Card. Test the loop by entering LOOP I
Defective PE card	Replace the affected card. Enable the card by entering LD 32 ENLC 1 s c Test the card by entering LD 30 SHLF 1 s
Defective backplane	Replace the card cage assembly in the UEM.



Clearing trunk faults

Chapter contents

Trunk faults	110
Fault clearing procedures	110
Symptoms:	
Trunk cannot make or receive calls (OVD message received)	112
Trunk cannot make or receive calls (no OVD message)	115

Trunk faults

Trunk cards provide the interface between the Peripheral Equipment buffer and various Central Office (CO) trunks. This chapter specifically considers two types of trunk cards:

- E&M Trunk: provides four ports, each of which can be individually configured to operate as
 - E&M signaling trunk
 - Two-wire Tie trunk
 - Four-wire Tie trunk
 - Paging trunk

- Universal Trunk: provides eight ports, each or which can be individually configured to operate as
 - Central Office trunk
 - Direct Inward Dialing (DID) trunk
 - Two-way Tie, Dial Repeating (2DR)
 - Two-way Tie, Outgoing Automatic Incoming Dial (OAID) trunk
 - Recorded Announcement (RAN) trunk
 - Music trunk
 - Paging trunk

Trunk faults can cause problems (such as noise) on outside calls and can keep calls from coming in or going out.

Fault clearing procedures

Manual Continuity Tests can be used to isolate Superloop Network Card and Intelligent Peripheral Equipment faults. For a description of Manual Continuity Tests, see *General maintenance information* (553-3001-500). See “LD45” the XI *input/output guide* (553-3001-400) for details on performing the tests.

Table 12 lists common trunk fault indications. To clear faults, select the symptom in “Chapter contents” that most resembles the fault indications and go through the procedure for clearing each possible cause until the fault is fixed. Once **the** fault is corrected, disregard the remaining possible causes.

Note: Clear any power or Common Equipment faults before you try to clear telephone set faults.

If **the** fault is not cleared after you have gone through each possible cause, check the most recent fault indications. Also check “How to clear faults” to see if another type of fault is indicated.

After the fault is corrected, go to “Final maintenance procedure” to completely restore normal operation.

Table 12
Trunk fault indicators

Indicator	Possible indications
System messages	<ul style="list-style-type: none"> • ERR090, 220,270 • OVD001—010 • TRK messages
Visual indicators	<ul style="list-style-type: none"> • Red LED lit on trunk card
User reports	<ul style="list-style-type: none"> • Users have trouble with a specific trunk • Callers report continuous ringing • Trouble with calls on console and/or telephone sets

WARNING

UEM covers are not hinged; do *not* let go of the cover. Lift the cover away from the UEM and set it out of your work area.

Symptom: Trunk cannot make or receive calls (OVD message received)

You cannot make or receive calls over a trunk and an overload (OVD) system message is received. The message indicates only **the** TN for this trunk has been disabled. Look up all system messages and **maintenance** display codes in **the XI1 input/output guide** (553-3001-400) and follow the instructions given. If the fault does not clear, use this procedure.

Manual continuity **loopback** tests can be used to isolate faults to Intelligent Peripheral Equipment, such as E&M and Universal Trunk Cards. See “LD45” the **XII input/output guide** (553-3001-400) for details on performing the tests.

Note: Constantly observe and look up system messages as you perform this procedure.

Replace equipment as described in **Hardware replacement** (553-3001-520). You may need to replace:

- E&M Trunk Card NT8D15AA
- Universal Trunk Card: NT8D14AA
- Any other trunk card
- **Conference/TDS** Card: NT8D17AA
- **Digitone** Receiver (DTR) Card: NT8D16AA
- **Network/DTR** Card: NT8D18AA
- Trunk equipment (such as music source or paging equipment)
- Peripheral Equipment (PE) or Intelligent Peripheml Equipment Card Cage Assembly: NT8D 1303, NT8D3703

Possible cause	Action
Defective trunk card	If the indicated card is an E&M or Universal Trunk Card, hardware disable then reenable the card to initiate a self-test. If the test fails, replace the card. If the test passes, follow the procedure below. Disconnect the wiring between the card and the cross-connect terminal.

Enable the TN by entering

LD 32

ENLU l s c u

("l s c u" represents loop, shelf, card, and unit numbers) Wait for an OVD message. If you receive an OVD message, replace the card.

If you do not receive an OVD message, reconnect the wiring and go to the next possible cause.

Defective wiring

At the main cross-connect terminal, disconnect the wiring to the CO or other trunk equipment (such as a music source or paging equipment).

Enable the TN and wait for an OVD message. If you receive an OVD message, repair or replace the wiring to the PE shelf.

If there is no OVD message, repair or replace the wiring from the cross-connect terminal to the telephone set.

If the trunk card still will not enable or there is still a trunk problem, reconnect the wiring and go to the next possible cause.

Defective trunk equipment

Make sure the CO equipment or other trunk equipment is not defective.

If there is no problem with this equipment, go to the next possible cause.

Defective DTR, TDS, or MFS

Use the attendant console to seize trunks and audibly test for dial tone and outpulsing, or use a maintenance telephone and enter

LD 36

TRK l s c u

Note: See the XII input/output guide for information on using this test.

If you do not hear outpulsing, the **Digitone** Receiver, Tone and Digit Switch, or Multi-Frequency Sender may not be sending or receiving digits and the fault will affect more than one trunk. See the procedures for clearing faults on this equipment.

If there is no problem with this equipment, go to the next possible cause.

-continued --

114 Clearing trunk faults

Possible cause	Action
Defective PE shelf	<p>Unseat the affected trunk card and enable the TN.</p> <p>If you do not receive an OVD message, test superloop TNs by entering LD 30 UNTTIs cu</p> <p>Test TNs on other loops by entering LD 45 TEST</p> <p>If you receive an OVD message, replace the card cage assembly in the UEM.</p>

Symptom: Trunk cannot make or receive calls (no OVD message)

You cannot make or receive calls over a trunk, but there is no overload (OVD) or other system message showing the TN for this trunk is defective or has been disabled. Look up all system messages and maintenance display **codes in the XII input/output guide (553-3001-400)** and follow the instructions given. If the fault does not clear, use this procedure.

Manual continuity **loopback** tests can be used to isolate faults to Intelligent Peripheral Equipment, such as E&M and Universal Trunk Cards. See “LD45” the XII **input/output guide (553-3001-400)** for details on performing the tests.

Note: Constantly observe and look up system messages as you perform this procedure.

Replace equipment as described in **Hardware replacement (553-3001-520)**. You may need to replace:

- E&M Trunk Card: NT8D15AA
- Universal Trunk Card: NT8D14AA
- Any other trunk card
- Conference/TDS Card: NT8D17AA
- Digitone Receiver (DTR) Card: NT8D16AA
- Network/DTR Card: NT8D18AA
- Trunk equipment (such as music source or paging equipment)

Possible cause	Action
Defective trunk equipment	Make sure the CO equipment or other trunk equipment is not defective. If there is no problem with this equipment, go to the next possible cause.

-continued —

Possible cause	Action
Disabled or defective TN	<p>Test TNs on superloops by entering LD 30 UNTT l s c u (“l s c u” represents loop, shelf, card, and unit numbers)</p> <p>Test TNs on other loops by entering LD 45 TEST</p> <p>If the test fails, replace the indicated item and test again.</p>
Defective trunk card	<p>If the card is an E&M or Universal Trunk Card, hardware disable then reenable the card to initiate a self-test.</p> <p>If the test fails, replace the card.</p> <p>If the test passes, go to the next possible cause.</p>
Defective wiring	<p>At the main cross-connect terminal, disconnect the wiring to the CO or other trunk equipment.</p> <p>Enable the TN and wait for an OVD message. If you receive an OVD message, repair or replace the wiring to the PE shelf.</p> <p>If there is no OVD message, repair or replace the wiring from the cross-connect terminal to the telephone set.</p> <p>If the trunk card still will not enable or there is still a trunk problem, reconnect the wiring and go to the next possible cause.</p>
Defective DTR, TDS, or MFS	<p>Use the attendant console to seize trunks and audibly test for dial tone and outpulsing, or use a maintenance telephone and enter LD 36 TRK l s c u</p> <p><i>Note: See the XII input/output guide</i> for information on using this test.</p>

If you do not hear **outpulsing**, the **Digitone** Receiver, Tone and Digit Switch, or Multi-Frequency Sender may not be sending or receiving digits and the fault will affect more than one trunk. See the procedures for clearing faults on this equipment.

If there is no problem with this equipment, go to the next possible cause.

Excessive traffic in the system

Additional trunk cards may be required to handle the traffic in the system. See *Traffic measurement* (553-2001-450).





Clearing attendant console faults

Chapter contents

Attendant console faults	120
Fault clearing procedures	121
Symptoms:	
Console cannot make or receive calls (OVD message received)	122
Console cannot make or receive calls (no OVD message)	124
Indicator or digit display not functioning properly	126
Operator cannot hear or be heard properly	128



Attendant console faults

Attendant consoles are the operator's interface to the system and its features. Components that can cause an attendant console fault are:

- the console itself or add-on units
- the console power supply
- the building wiring
- the cross-connect from the console to **the** line circuit
- the unit on the peripheral line card
- the peripheral line card
- the ringing generator
- the peripheral controller card
- the peripheral module power
- the peripheral module backplane

Attendant console faults typically affect only a single attendant. However; if more **than** one attendant console is affected, look for connections such as.

- they are on the same line card
- they are on the same UEM
- they are on the same loop
- they are served by the same peripheral controller
- there is a problem with ringing or tones

Use the following software programs to isolate attendant console faults:

- LD 30 to test peripheral controllers
- LD 3 1 to test sets and consoles
- LD 32 to test network loops
- LD 45 to perform
 - signaling tests
 - manual continuity tests

Fault clearing procedures

Table 13 lists common attendant console fault indications. To clear faults, select the symptom in “Chapter contents” that most resembles the fault indications then go through the procedure for clearing each possible cause until the fault is fixed. Once the fault is corrected, disregard the remaining possible causes.

Note: Clear any power or Common Equipment faults before you try to clear attendant console faults.

If the fault is not cleared after you have gone through each possible cause, check the most recent fault indications. Also check “How to clear faults” to see if another type of fault is indicated.

After the fault is corrected, go to “Final maintenance procedure” to completely restore normal operation.

Table 13
Common attendant console fault indicators

Indicator	Possible Indications
System messages	<ul style="list-style-type: none"> • BSD501—The console (identified by loop, shelf, card, and unit) failed the signaling test. If the unit number is preceded by a minus sign, the console was disabled. There is a console fault or a fault on the Peripheral Equipment card indicated.
Visual indicators	<ul style="list-style-type: none"> • Red LED lit on associated cards
User reports	<ul style="list-style-type: none"> • Trouble with calls • Trouble with equipment (such as handset, headset, or display)

WARNING

UEM covers are not hinged; do *not* let go of the cover. Lift the cover away from the UEM and set it out of your work area.

Symptom: Console cannot make or receive calls (OVD message received)

The attendant console cannot make or receive **calls**. There is an OVD message indicating a TN for the attendant console has been disabled. Look up all system messages and maintenance display codes in the *XI 1 input/output guide (553-3001-400)* and follow the instructions given. If the fault does not clear, use this procedure.

Note: Constantly observe and look up system messages as you perform this procedure.

See *Installation procedures for telephone sets and attendant consoles* (553-3001-215) for information on connecting attendant consoles. See ***System installation procedures* (553-3001-210)** for information on system cabling. To replace other equipment, **see *Hardware replacement* (553-3001-520)**. You may need to replace:

- Attendant console
 - Peripheral Equipment (PE) card associated with the console
- Common/Peripheral Equipment, Peripheral Equipment, or Intelligent Peripheral Equipment Card Cage Assembly: NT8D1103, NT8D1303, NT8D3703

Possible cause	Action
Defective PE card	<p>Software disable the TN indicated by the OVD message by entering LD 32 DISU l s c u ("l s c u" represents loop, shelf, card, and unit number)</p> <p>Disconnect the wiring between the PE card and the cross-connect terminal.</p> <p>Reenable the TN by entering ENLU l s c u and wait for an OVD message</p>

If you receive a message indicating a problem with the card or unit, replace the card.

If you do not receive a message indicating a problem with the card or unit, reconnect the wiring and go to the next possible cause.

- | | |
|---------------------|--|
| Defective console | <p>Disable the TN. Disconnect the wiring from the console to the jack. Reenable the TN and wait for an OVD message.</p> <p>If you do not receive an OVD message, replace the console.</p> <p>If you receive an OVD message, reconnect the wiring and go to the next possible cause.</p> |
| Defective wiring | <p>Disable the TN. Disconnect the wiring between the console and the cross-connect terminal.</p> <p>Reenable the TN and wait for an OVD message.</p> <p>If you do not receive an OVD message, replace or repair the wiring between the console and the cross-connect terminal.</p> <p>If you receive an OVD message, replace or repair the wiring between the PE shelf and the cross-connect terminal.</p> <p>If there is still a console problem, reconnect all wiring and go to the next possible cause.</p> |
| Defective backplane | <p>Disable the TN. Unseat the affected PE card.</p> <p>Reenable the TN and wait for an OVD message.</p> <p>If you receive an OVD message, replace the card cage assembly in the UEM.</p> |

Symptom: Console cannot make or receive calls (no OVD message)

The attendant console cannot make or receive calls. There is no OVD message. There may be other system messages indicating the TN for this console is defective or has been disabled. Look up all system messages and maintenance display codes in the *X11 input/output guide* (553-3001-400) and follow the instructions given. If the fault does not clear, use this procedure.

Note: Constantly observe and look up system messages as you perform this procedure.

See Installation procedures for telephone sets and attendant consoles (553-3001-215) for information on connecting attendant consoles. **See System installation procedures** (553-3001-210) for information on system cabling.

Possible cause	Action
No power to console	<p>Check the power supply and wiring to see that the console is powered up.</p> <p>If there is a power supply problem, correct it.</p> <p>If there is no power problem, go to the next possible cause.</p>
Defective console	<p>Test the console by entering LD 31 (<i>See the X11 input/output guide</i> for information on testing consoles with LD 31.)</p> <p>If the console fails the test, replace it.</p> <p>If the console passes the test, go to the next possible cause.</p>
Console connected to wrong TNs	<p>Check the cross-connect terminal to make sure the console is connected to the correct TNs.</p> <p>If the console is not connected correctly, fix the wiring.</p> <p>If the console is connected correctly, go to the next possible cause.</p>

- Disabled TN Software disable then reenable each TN by entering
LD 32
DISU l s c u
ENLU l s c u
(“l s c u” represents loop, shelf, card, and unit number)
Test **TNs** on superloops by entering
LD 30
UNTT l s c u
Test **TNs** on other loops by entering
LD 45
TEST
If **there** is still a console problem, go to the next possible cause.
- Defective wiring Make sure wiring is properly connected and wires are not interchanged,
crossed, or grounded
— check the wiring between the console and the cross-connect
terminal
— check the wiring between the Peripheral Equipment shelf and the
cross-connect terminal
If there is a wiring problem, correct it.

Symptom: Indicator or digit display not functioning properly

The attendant console operates, but some LCD indicators or digit displays are not functioning properly. Look up all system messages and maintenance display *codes* in *the X11 input/output guide* (553-3001-400) and follow the instructions given. If the fault does not clear, use **this** procedure.

Note: Constantly observe and look up system messages as you perform this procedure.

See Installation procedures for telephone sets and attendant consoles (553-3001-215) for information on connecting attendant consoles.

Possible cause	Action
Disconnected or defective power supply	Make sure the required power supplies to the attendant console are connected and are not defective. If there is still a console problem, go to the next possible cause.
Disabled TN	Software disable then reenable each TN by entering LD 32 DISU l s c u ENLU l s c u ("l s c u" represents loop, shelf, card, and unit number) Test TNs on superloops by entering LD 30 UNTT l s c u Test TNs on other loops by entering LD 45 TEST If there is still a console problem, go to the next possible cause.
Feature not assigned	Make sure the feature or the indicator is assigned in software (see the <i>X11 input/output guide</i>). If there is still a console problem, go to the next possible cause.

Defective console Test the console by entering
LD 31
(See the XII input/output guide for information on testing consoles
with LD 31.)
If the console fails the test, replace it.

Symptom: Operator cannot hear or be heard properly

The attendant console operates, but the user cannot hear or be heard properly. Look up all system messages and maintenance display codes in **the XII input/output guide (553-3001-400)** and follow the instructions given. If the fault does not clear, use this procedure.

Note: Constantly observe and look up system messages as you perform this procedure.

See Installation procedures for telephone sets and attendant consoles (553-3001-215) for information on connecting attendant consoles. **See System installation procedures (553-3001-210)** for information on system cabling. To replace other equipment, **see Hardware replacement (553-3001-520)**.

Possible cause	Action
Defective headset or handset	<p>Make sure the handset or headset is plugged into the correct jack on the console.</p> <p>Try another handset or headset.</p> <p>If the test equipment works, replace the equipment.</p> <p>If there is still a console problem, go to the next possible cause.</p>
Defective console	<p>Test the console by entering LD 31 (See the XII input/output guide for information on testing consoles with LD 31.)</p> <p>If the console fails the test, replace it.</p> <p>If the console passes the test, go to the next possible cause.</p>

Defective
Peripheral
Equipment card

Software disable each TN by entering

LD 32

DISU l s c u

("l s c u" represents loop, shelf, card, and unit number)

Disconnect the wiring between the PE card and the cross-connect terminal.

Reenable and test each TN by entering

ENLU l s c u

Wait for an OVD message. If you receive a message indicating a problem with the card or unit, replace the card.

If you do not receive a message indicating a problem with the card or unit, reconnect the wiring and go to the next possible cause.

Defective wiring
to console

Make sure wiring is properly connected and wires are not interchanged, crossed, or grounded

- check the wiring between the console and the cross-connect terminal
- check the wiring between the PE shelf and the cross-connect terminal

If there is a wiring problem, correct it.



Clearing telephone set faults

Chapter contents

Telephone set faults	131
Fault clearing procedures	132
Symptoms:	
Telephone set cannot make or receive calls (OVD message received)	134
Telephone set cannot make or receive calls (no OVD message)	136
One end cannot hear or cannot be heard	138
Noise or low volume on all calls	140
Defective indicator, digit display, or component	142
Defective feature	144
Defective add-on module	145
Cannot dial from 2500-type telephone set	146
No ring on 500- and 2500-type telephone sets	148

Telephone set faults

Telephones and terminals are the user's interface to the system and its features. Components that can cause a telephone set fault are:

- the set itself or add-on units
- the set power supply
- **the building wiring**
- the cross-connect from the set to the line circuit
- the unit on the peripheral line card

- the peripheral line card
- the ringing generator
- the peripheral **controller** card
- the peripheral module power
- the peripheral module backplane

Telephones and terminal faults typically affect only a single user. However, if more than one telephone set is affected, look for connections such as:

- they are on the same line card
- they are on the same UEM
- they are on the same loop
- they are served by the same peripheral controller
- there is a problem with ringing or tones

Use the following software programs and tests to isolate telephone set faults:

- LD 30 to test peripheral controllers
- LD 3 1 to test sets and consoles
- LD 32 to test network loops
- LD 45 to perform signaling tests
- Meridian Modular Telephone self-test

Fault clearing procedures

Table 14 lists common telephone set fault indications. To clear faults, select the symptom in “Chapter contents” that most resembles the fault indications and go through the procedure for clearing each possible cause until the fault is fixed. Once the fault is corrected, disregard the remaining possible causes.

Note: Clear any power or Common Equipment faults before you try to clear telephone set faults.

If the fault is not cleared after you have gone through each possible cause, check the most recent fault indications. Also check “How to clear faults” to see if another type of fault is indicated.

After the fault is corrected, go to “Final maintenance procedure” to completely restore normal operation.

Table 14
Telephone set fault indicators

Indicator	Possible indications
System messages	<ul style="list-style-type: none">• BSD501• ERR500• MWL500• NWS501• OVD001—010• XMI messages
Visual indicators	<ul style="list-style-type: none">• Red LED lit on associated cards
User reports	<ul style="list-style-type: none">• Trouble with calls• Trouble with equipment (such as handset or add-on module)

WARNING

UEM covers are not hinged; do not let go of the cover. Lift the cover away from the UEM and set it out of your work area.

Symptom: Telephone set cannot make or receive calls (OVD message received)

The telephone set cannot make or receive calls. There is an OVD message indicating the TN for only this set has been disabled. Look up all system messages and maintenance display codes in *the XII input/output guide* (553-3001-400) and follow the instructions given. If the fault does not clear, use this procedure.

Note: Constantly observe and look up system messages as you perform this procedure.

See Installation procedures for telephone sets and attendant consoles (553-3001-215) for information on connecting telephone sets. See **System installation procedures** (553-3001-210) for information on system cabling. To replace other equipment, **see Hardware replacement** (553-3001-520). You may need to replace:

- Peripheral Equipment (PE) card
- Telephone set
- Wiring between the cross-connect terminal and the telephone set
- Wiring between the Peripheral Equipment shelf and the telephone set
- Common/Peripheral Equipment, Peripheral Equipment, or Intelligent Peripheral Equipment Card Cage Assembly: NT8D1103, NT8D1303, NT8D3703

Possible cause	Action
Defective PE card	<p>Software disable the TN indicated by the OVD message by entering LD 32 DISU l s c u (“l s c u” represents loop, shelf, card, and unit number)</p> <p>Disconnect the wiring between the PE card and the cross-connect terminal.</p>

Reenable the TN by entering

ENLU1scu

and wait for an OVD message

If you receive a message indicating a problem with the card or unit, replace the card.

If you do not receive a message indicating a problem with the card or unit, reconnect the wiring and go to the next possible cause.

Defective
telephone set

Note: If the set is a Meridian Modular Telephone, enter

LD 32

IDU1scu

If there is no response, replace the set.

If there is an appropriate response, continue this procedure.

Disable the set TN. Disconnect the wiring from the set to the jack.

Reenable the TN and wait for an OVD message.

If you do not receive an OVD message, replace the set.

If you receive an OVD message, reconnect the wiring and go to **the** next possible cause.

Defective wiring

Disable the TN. Disconnect the wiring between the set and the cross-connect terminal.

Reenable the TN and wait for an OVD message.

If you do not receive an OVD message, replace or repair **the** wiring between the set and the cross-connect terminal.

If you do not receive an OVD message, replace or repair the wiring between the set and the cross-connect terminal.

If there is still a set problem, reconnect all wiring and go to the next possible cause.

Defective
backplane

Disable the TN. Unseat the affected PE card.

Reenable **the** TN and wait for an OVD message.

If you receive an OVD message, replace the card cage assembly in the UEM.

Symptom: Telephone set cannot make or receive calls (no OVD message)

The telephone set cannot make or receive calls. There is no OVD message or other system message indicating the TN for this set is defective or disabled. There may or may not be dial tone when the handset is unhooked. Look up all system messages and maintenance display codes in the **XI / input/output guide** (553-3001-400) and follow the instructions given. If the fault does not clear, use this procedure.

Note: Constantly observe and look up system messages as you perform this procedure.

See Installation procedures for telephone sets and attendant consoles (553-3001-215) for information on connecting telephone sets. See **System installation procedures** (553-3001-210) for information on system cabling. To replace other equipment, **see Hardware replacement** (553-3001-520).

Possible cause	Action
No power to digital telephone set	<p>Check the power supply (if one is required) and make sure it is not defective.</p> <p>If there is a power supply problem, correct it.</p> <p>If there is no problem with the power supply, go to the next possible cause.</p>
Set connected to wrong TNs	<p>Check the cross-connect terminal to make sure the set is connected to the correct TN.</p> <p>If the set is not connected correctly, fix the wiring.</p> <p>If the set is connected correctly, go to the next possible cause.</p>

- Disabled TN Software disable then reenable the set TN by entering
LD 32
DISU l s c u
ENLU l s c u
("l s c u" represents loop, shelf, card, **and** unit number)
Test TNs on superloops by entering
LD 30
UNTT l s c u
Test TNs on other loops by entering
LD 45
TEST
If there is still a set problem, go to the next possible cause.
- Defective telephone set Disconnect the set from the jack. Plug in another set of the same type.
If the replacement set works, replace the set you removed.
If the replacement set does not work, reconnect **the** original set and go to the next possible cause.
Note: If the set is a Meridian Modular Telephone, enter
LD 32
IDU l s c u
If there is no response, replace the set.
If there is an appropriate response, see "Add-on modules"
in *Installation procedures for telephone sets and attendant consoles* for self-test instructions.
- Defective wiring Make sure wiring is properly connected and wires are not interchanged, crossed, or grounded
— check the wiring between the set and the cross-connect terminal
— check the wiring between the PE shelf and the cross-connect terminal
If there is a wiring problem, correct it.

Symptom: One end cannot hear or cannot be heard

The person at the far end can hear you but you cannot hear them or the person at the **far** end cannot hear you but you can hear them. Look up all system messages and maintenance display **codes** in **the XII input/output guide (553-3001-400)** and follow the instructions given. If the fault does not clear, use this procedure.

Note: Constantly observe and look up system messages as you perform this procedure.

See Installation procedures for telephone sets and attendant consoles (553-3001-215) for information on connecting telephone sets. See **System installation procedures (553-3001-210)** for information on system cabling. To replace other equipment, **see Hardware replacement (553-3001-520)**. You may need to replace:

- Peripheral Equipment (PE) card
- Telephone handset
- Telephone set
- Wiring to the telephone set

Possible cause	Action
Fault on other equipment	<p>Check with the user to determine if the fault is present only on</p> <ul style="list-style-type: none"> — certain types of calls (such as on a paging trunk or a Tie trunk) — calls to a specific location — calls to a specific telephone or other piece of equipment (such as a modem or Fax machine) <p>If the fault occurs only with certain calls, take the appropriate action.</p> <p>If the fault occurs on all calls, go to the next possible cause.</p>
Defective handset	<p>Check the receiver or transmitter in the handset. If one is defective, replace the handset or, if necessary, the telephone set.</p>

Defective
telephone set

Disconnect the set from the jack. Plug in another set of the same type.
If the replacement set works, replace the set you removed.
If the replacement set does not work, reconnect the original set and go to the next possible cause.

Note: If the set is a Meridian Modular Telephone, enter

LD 32

IDU l s c u

If there is no response, replace the set.

If there is an appropriate response, see "Add-on modules" in *Installation procedures for telephone sets and attendant consoles* for self-test instructions.

Defective PE
card

Software disable the set TN by entering

LD 32

DISU l s c u

("l s c u" represents loop, shelf, card, and unit number)

Disconnect the wiring between the PE card and the cross-connect terminal.

Reenable and test the TN by entering

ENLU l s c u

Wait for an **OVD** message. If you receive a message indicating a problem with the card or unit, replace the card.

If you do not receive a message indicating a problem with the card or unit, reconnect the wiring and go to the next possible cause.

Defective wiring
to set

Make sure wiring is properly connected and wires are not interchanged, crossed, or grounded

- check the wiring between the set and the cross-connect terminal
- check the wiring between the PE shelf and the cross-connect terminal

If there is a wiring problem, correct it.

Symptom: Noise or low volume on all calls

There is noise on the line on all calls or the volume is lower than usual on all calls. Look up all system messages and maintenance displaycodes in the XII *input/output guide* (553-3001-400) and follow the instructions given. If the fault does not clear, use **this** procedure.

Note: Constantly observe and look up system messages as you perform this procedure.

See Installation procedures for telephone sets and attendant consoles (553-3001-215) for information on connecting telephone sets. See *System installation procedures* (553-3001-210) for information on system cabling. To replace other equipment, **see Hardware replacement** (553-3001-520). You may need to replace:

- Peripheral Equipment (PE) card
- Telephone set
- Wiring to the telephone set

Possible cause	Action
Defective wiring	<p>Make sure wiring is properly connected and wires are not interchanged, crossed, or grounded</p> <ul style="list-style-type: none">— check the wiring between the set and the cross-connect terminal— check the wiring between the PE shelf and the cross-connect terminal <p>If there is a wiring problem, correct it.</p> <p>If there is no problem with the wiring, go to the next possible cause.</p>

Defective
telephone set

Disconnect the set from the jack. **Plug** in another set of the same type.
If the replacement set works, replace the set you removed.

If the replacement set does not work, reconnect the original set and go to the next possible cause.

Note: If the set is a Meridian Modular Telephone, enter

LD 32

IDU l s c u

If there is no response, replace the set.

If there is an appropriate response, see "Add-on modules"
in *Installation procedures for telephone sets and attendant*
consoles for self-test instructions.

Defective PE
card

Software disable the set TN by entering

LD 32

DISU l s c u

("l s c u" represents loop, shelf, card, and unit number)

Disconnect the wiring between the PE card and the cross-connect terminal.

Reenable and test the TN by entering

ENLU l s c u

Wait for an OVD message. If you receive a message indicating a problem with the card or unit, replace the card.

If you do not receive a message indicating a problem with the card or unit, reconnect the wiring and go to the next possible cause.

Symptom: Defective indicator, digit display, or component

The telephone set can place and receive calls, but one or more LED or LCD indicator, a digit display, or a component (such as a handsfree unit) is not working. Look up all system messages and maintenance display codes in the *X11 input/output guide* (553-3001-400) and follow the instructions given. If the fault does not clear, use this procedure.

Note: Constantly observe and look up system messages as you perform this procedure.

See *Installation procedures for telephone sets and attendant consoles* (553-3001-215) for information on connecting telephone sets. To replace other equipment, **see *Hardware replacement*** (553-3001-520). You may need to replace:

- Power supply to telephone set
- Peripheral Equipment (PE) card
- Telephone set

Possible cause	Action
Set has incorrect software parameters	Disconnect then reconnect power to the set to force a reset and parameter download. If the fault is not cleared, go to the next possible cause.
No power to digital telephone set	Check the power supply (if one is required) and make sure it is not defective. If there is a power supply problem, correct it. If there is no problem with the power supply, go to the next possible cause.

Defective
telephone set

Disconnect the set from the jack. Plug in another set of the same type. If the replacement set works, replace the set you removed. If the replacement set does not work, reconnect the original set and go to the next possible cause.

Note: If the set is a Meridian Modular Telephone, enter

LD 32

IDU l s c u

If there is no response, replace the set.

If there is an appropriate response, see “Add-on modules” in *Installation procedures for telephone sets and attendant consoles* for self-test instructions.

Feature not
assigned

Make sure the feature or the indicator is assigned in software (see the *X11 input/output guide*).

If there is still a set problem, go to the next possible cause.

Symptom: Defective feature

The telephone set can make and receive calls, but one or more of its features (such as call transfer or ring again) is not working.. Look up **all** system messages and maintenance display codes in the ***X11 input/output guide*** (553-3001-400) and follow the instructions given. If the fault does not clear, use this procedure.

Note: Constantly observe and look up system messages as you perform this procedure.

See Installation procedures for telephone sets and attendant consoles (553-3001-215) for information on connecting telephone sets.

Possible cause	Action
Feature not assigned	<p>Make sure the feature or the indicator is assigned in software (see the <i>X1 1 input/output guide</i>).</p> <p>If there is still a console problem, go to the next possible cause.</p>
Defective telephone set	<p>Disconnect the set from the jack. Plug in another set of the same type.</p> <p>If the replacement set works, replace the set you removed.</p> <p>If the replacement set does not work, reconnect the original set and go to the next possible cause.</p> <p>Note: If the set is a Meridian Modular Telephone, enter LD 32 IDU 1 s c u If there is no response, replace the set. If there is an appropriate response, see “Add-on modules” in Installation procedures for telephone sets and attendant consoles for self-test instructions.</p>

Symptom: Defective add-on module

The telephone set can make and receive calls, but an add-on module connected to it is not working. Look up all system messages and maintenance display **codes** in *the XII input/output guide (553-3001-400)* and follow the instructions given. If the fault does not clear, use this procedure.

Note: Constantly observe and look up system messages as you perform this procedure.

See *Installation procedures for telephone sets and attendant consoles* (553-3001-215) for information on connecting telephone sets. You may need to replace:

- Add-on module
- Data option card
- Power supply for add-on module

Possible cause	Action
Defective power supply for add-on module	If the add-on module requires a separate power supply, make sure it is properly connected. If there is still a set problem, go to the next possible cause.
Defective add-on module	Replace the add-on module.
Defective data option card	If the fault is with a data add-on module, replace the data option card.

Symptom: Cannot dial from **2500-type** telephone set

A user cannot dial from a **2500-type** telephone set. The condition may exist on more than one set and may be intermittent. The set may occasionally experience a “no dial tone” condition. Calls from other types of sets are not affected. Look up all system messages and maintenance display codes in *the XI 1 input/output guide (553-3001-400)* and follow the instructions given. If the fault does not clear, use this procedure.

Note: Constantly observe and look up system messages as you perform this procedure.

See Installation procedures for telephone sets and attendant consoles (553-3001-215) for information on connecting telephone sets. See **System installation procedures (553-3001-210)** for information on system cabling. To replace other equipment, **see Hardware replacement (553-3001-520)**. You may need to replace:

- Digitone Receiver (DTR) Card: NT8D16AA
- Network/DTR Card: NT8D18AA
- Telephone set
- Wiring to the telephone set

Possible cause	Action
Defective telephone set	If only one set is affected, replace it. If there is still a set problem, go to the next possible cause.
Defective wiring	If only one set is affected, make sure wiring is properly connected and wires are not interchanged, crossed, or grounded <ul style="list-style-type: none"> — check the wiring between the set and the cross-connect terminal — check the wiring between the PE shelf and the cross-connect terminal If there is a wiring problem, correct it. If there is still a set problem, go to the next possible cause.

Defective
Digitone
Receiver

If the condition is intermittent or more than one set is affected, test the **Digitone** Receivers in the system by entering

LD 34

DTR l s c u

("l s c u" represents loop, shelf, card, and unit number of the DTR).

Replace any units that fail the test.

If there is still a set problem, go to the next possible cause.

Excessive
Digitone traffic

Additional **Digitone** Receivers may be required to handle the traffic in the system. See *Traffic measurement* (553-2001-450).

Symptom: No ring on 500- and 2500-type telephone sets

Both **500- and 2500-type** telephone sets do not ring. **One** or several **sets** in the same UEM are experiencing the problem. Look up all system messages and maintenance display codes in **the X11 input/output guide (553-3001-400)** and follow the instructions given. If the fault does not clear, use this procedure.

Note: Constantly observe and look up system messages as you perform this procedure.

See Installation procedures for telephone sets and attendant consoles (553-3001-215) for information on connecting telephone sets. See **System installation procedures (553-3001-210)** for information on system cabling. To replace other equipment, **see Hardware replacement (553-3001-520)**. You may need to replace:

- Ringing Generator: NT7D03AA, NT8D21 AA
- Peripheral Equipment (PE) card
- Telephone set
- Wiring to the telephone set
- Common/Peripheral Equipment, Peripheral Equipment, or Intelligent Peripheral Equipment Card Cage Assembly: NT8D1103, NT8D1303, NT8D3703

Possible cause	Action
Defective telephone set	If only one set is affected, replace it.
	If there is still a set problem, go to the next possible cause.
Defective wiring	If only one set is affected, make sure wiring is properly connected and wires are not interchanged, crossed, or grounded
	— check the wiring between the set and the cross-connect terminal
	— check the wiring between the PE shelf and the cross-connect terminal
	If there is a wiring problem, correct it.
	If there is still a set problem, go to the next possible cause.

Defective PE card	Software disable the set TN by entering. LD 32 DISU1 s c u ("1 s c u" represents loop, shelf, card, and unit number) Disconnect wiring between the PE card and the cross-connect terminal. Reenable and test the TN by entering ENLU1 s c u Wait for an OVD message. If you receive a message indicating a problem with the card or unit, replace the card. If you do not receive a message indicating a problem with the card or unit, reconnect the wiring and go to the next possible cause.
Defective Controller Card	If several sets on different cards in the same loop are affected, replace the Controller Card. If there is still a set problem, go to the next possible cause.
Defective Ringing Generator	If several sets on different cards in the same UEM are affected, replace the Ringing Generator for the shelf (even if the green LED on the unit is lit). If there is still a set problem, go to the next possible cause.
Defective backplane	If the green LED is lit on the Ringing Generator and the fault persists, replace the card cage assembly in the UEM.



Final maintenance procedure

Chapter contents

Introduction	147
Final maintenance procedure	148

introduction

Perform the final maintenance procedure (Procedure 4) to verify that the SL-1 is operating properly and there are no remaining faults.

WARNING

UEM covers are not hinged; do not let go of the cover. Lift the cover away from the UEM and set it out of your work area.

Procedure 4
Final maintenance procedure

- 1 Make sure all cards that may have been removed are **reinserted** in their assigned location and enabled.
- 2 Make sure all wiring and connectors that may have been disconnected are reconnected.
- 3 Make sure all loops and shelves that should be enabled are **enabled**.

Note: Digital telephone sets on a network loop that was disabled may not be restored when the loop is enabled. Each telephone **set** should be individually disabled and reenabled through LD 32. Service may also be restored by disconnecting and reconnecting the set line cord.

- 4 Make sure all circuit breakers are set to ON and any fuses (in **power** panels or auxiliary equipment) are inserted.

- 5** Clear fault indicators by entering LD 35

To clear the maintenance display in a single CPU system, enter CDSP

To clear the maintenance display in a dual CPU system, clear the display on one CPU by entering

CDSP

Switch **CPUs** by entering

SCPU

Clear the display on the other CPU by entering

CDSP

To clear a major alarm indication and restore Power Fail Transfer Units (**PFTUs**) to normal operation, enter

CMAJ

To clear a minor alarm indication from all attendant consoles, enter

CMIN ALL

- 6 Set the midnight routine to run after you log out of the system by entering
MIDN
End the session in LD 35 and log out of the system

LOGO
(the midnight routine will now run)
- 7 Check system messages produced when the midnight routine runs.
Clear any faults indicated.
- 8 If there was a sysload (reload) while you were clearing a fault, reset the correct time and date by entering
LD2
STAD (day) (month) (year) (hour) (minute) (second)
Check the time and date you entered
TTAD
End the session in LD 2 and log out of the system

LOGO
- 9 Replace any covers you removed from **UEMs**.
- 10 Tag defective equipment with a description of the fault and return it-to a repair center.

SL-1
System options 21, 51, 61, 71

Fault clearing

Copyright © 1990 Northern Telecom
All rights reserved.
Information subject to change without notice.
Release 2.0
Standard
February 28, 1990
Printed in U.S.A.



553-3001-520

SL-1

System options 21, 51, 61, 71

Hardware replacement

Standard

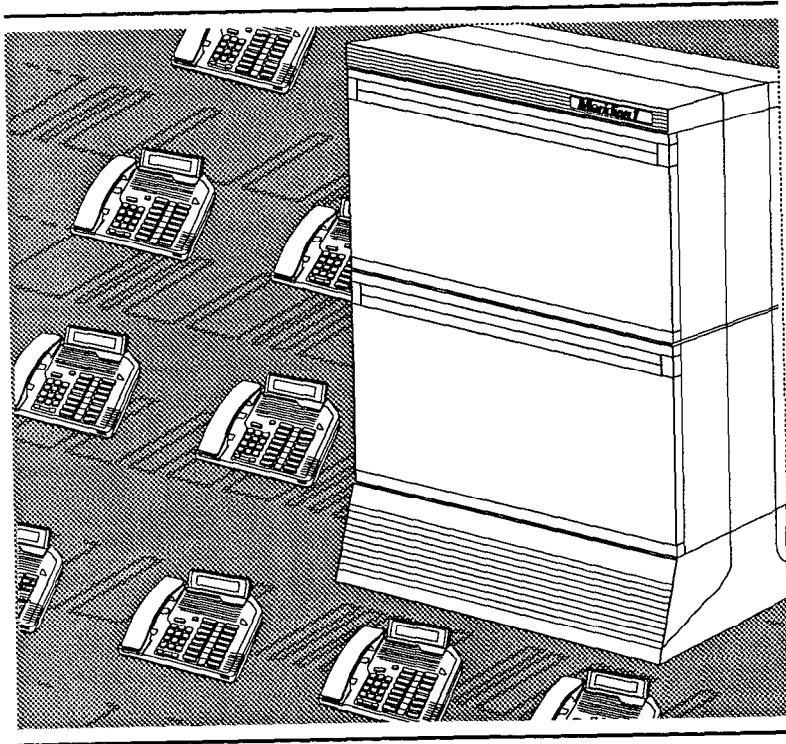

nt northern
telecom

Meridian 1
Communication Systems





SL- 1

System options **21, 51, 61, 71**

Hardware replacement

Publication number: 553-3001-520
Document release: 1 .0
Document status: Standard
Date: January 29,1QQ0



© 1990 Northern Telecom

All rights reserved.

Hardware replacement 553-3001-520

Revision history

January 29, 1990

Standard, release 1.0



Contents

About this document	1
References	2
<hr/>	
Accessing the system	3
Chapter contents	3
Introduction	3
Access through the system terminal	4
Access through the maintenance telephone	6
<hr/>	
Replacing equipment	9
Chapter contents	9
Removing UEM covers	11
A0367754 Top Cap Fan (system option 21 A)	12
NT6D3903 CPU/Network Card Cage Assembly	16
NT6D40AA, NT6D41AA, NT7D03AA, NT7D04AA Power Supply DC	22
NT6D52AA Rectifier	24
NT7D1 OAA Power Distribution Unit DC	26
NT7D14AA, NT8D06AA, NT8D21AA, NT8D29AA Power Supply AC	30
NT7D15AA System Monitor (system option 21 A)	32
NT7D17AC and NT7D17DC Fan Unit	34
NT8D01AC and NT8D01AD Controller Card	36
NT8D02AA, NT8D03AA, NT8D09AA, NT8D14AA, NT8D15AA, NT8D16AA, QPC353, QPC397, QPC430, QPC432 Peripheral Equipment Card	38
NT8D04AA Superloop Network Card and QPC414 Network Card	40
NT8D17AA Conference/TDS Card	42
NT8D18AA Network/DTR Card	44

NT8D19AA	Memory/Peripheral Signaling Card	46
NT8D22AB	System Monitor	48
NT8D39AA	Power Fail Transfer Unit	50
NT8D41 AA	Serial Data Interface paddle board	52
NT8D46AC and NT8D46DC	Thermostat Harness	54
NT8D46AM	Air Probe Harness	62
NT8D52AA and NT8D52DC	Blower Unit	66
NT8D53AB	Power Distribution Unit AC	68
NT8D53AD	Power Distribution Unit (system option 21A)	72
NT8D56AA, NT8D56AC, NT8D57AA	Module Power Distribution Unit	76
NT8D68AA	Floppy Disk Unit	80
NT8D69AA	Multi Disk Unit	82
NT8D1103	Common/Peripheral Equipment Card Cage Assembly	84
NT8D1303	Peripheral Equipment Card Cage Assembly	88
NT8D3403	CPU Card Cage Assembly	92
NT8D3503	Network Card Cage Assembly	96
NT8D3703	Intelligent Peripheral Equipment Card Cage Assembly	102
QMM42	Data Cartridge	106
QPC43	Peripheral Signaling Card	108
QPC215	Segmented Bus Extender Card and QPC441 Three Port Extender Card	110
QPC412 InterGroup	Switch Card	114
QPC471 and QPC775	Clock Controller Card	116
QPC477	Bus Terminating Unit	120
QPC513 and QPC841	Serial Data Interface Card	122
QPC579	CPU Function Card	124
QPC580	CPU Interface Card	126
QPC581	Changeover and Memory Arbitrator Card	128
QPC583	Memory Card	130
QPC584	Mass Storage Interface Card and QPC742 Floppy Disk Interface Card	132
QPC659	Dual Loop Peripheral Buffer Card	134
QPC687	CPU Card	136
QPC939	Read Only Memory Card	138
QPC940	Read Only Memory Card	140
<hr/> Index		141

About this document

This document tells you how to replace hardware in SL- 1 system options 21, 51, 61, and 71. In this manual, “replacing hardware” means removing a faulty piece of equipment and installing identical operating equipment. The procedures in this document are based on the assumption that the SL-1 is properly installed (for example, all card locations, option switch settings, and cable connections are correct) and was fully operational before the hardware fault.

To use **this** document, you should have a basic knowledge of SL-1 maintenance procedures. Generally, only common tools (such as socket wrenches, screwdrivers, and pliers) are required to perform these procedures.

This document does not provide procedures for locating and clearing faults. See *Fault clearing* (553-3001-510) to locate and clear faults.

Information in this document is written in a two-page modular format wherever possible. However, material which must be included in a module sometimes takes only one page or more than two pages. In these cases, the page between modules may be left blank.

References

See the *SL-I planning and engineering guide* for

- *Master index* (553-3001-000)
- *System overview* (553-3001-100)
- *Sparesplanning* (553-3001-153)
- *Equipment identification and ordering* (553-3001-154)

See the list of line and trunk circuit descriptions in *the Master index* (553-3001-000) for specific references to lines and trunks.

See the *SL-I installation and maintenance guide* for

- *System installation procedures* (553-3001-210)
- *Circuitpack installation and testing* (553-3001-211)
- *Installation procedures for telephone sets and attendant consoles* (553-3001-215)
- *General maintenance information* (553-3001-500)
- *Fault clearing* (553-3001-510)

See the *SL-1 X11 software guide* for an overview of software architecture, procedures for software installation and management, and a detailed description of all X11 features and services. This information is contained in two documents:

- *X11 software management* (553-3001-300)
 - *X11 features and services* (553-3001-305)

See the *SL-1 X11 input/output guide* (553-3001-400) for a description of all administration programs, maintenance programs, and system messages.

Accessing the system

Chapter contents

Introduction	3
Access through the system terminal	4
Access through the maintenance telephone	6

Introduction

When you replace equipment, you often send commands to the SL-1 software in order to disable faulty equipment and to enable and test newly installed equipment.

You send maintenance commands to the system through the *system terminal* or *the maintenance telephone*. This chapter gives the procedures for accessing the system through these devices.

Access through the system terminal

You can send maintenance commands and receive system messages by accessing the CPU through an RS-232 device, such as a video display terminal (VDT).

When you access the system through a system terminal, a log in procedure is required (see Procedure 1). All system passwords are initially set as **0000**, but you can change **passwords** through the Configuration Record (LD 17).

Note: If a sysload (system reload) occurs before you save a new password in a data dump, the last active password remains valid.

Each system has two levels of passwords: level 1 is for general use, level 2 is for administrative use. Either password is accepted in the log in procedure.

Procedure 1 Accessing the system terminal

- 1 Press the return key.
 - If the response is **OVLIII nm TTY** or **OVLIII nm SL1** someone else is logged into the system. When they have logged off, press return and go to Step 2.
 - If the response is **OVLIII nm IDLE** or **OVLIII nm BKGD** you are ready to log into the system. Go to Step 2.
 - If the response is **OVL000 >** you are already logged into the system. Go to Step 4.

Note: Responses may vary with different Background Terminal packages.

- 2 Enter
LOGI
then press the return key.
The normal response is
PASS?
If **there** is **any** other response, **see the XII input/output guide**
(553-3001-400).
 - 3 Enter either the level 1 or level 2 password and press the return key.
If the password is correct, the system responds with the prompt
>
 - 4 Enter
LD xx
“xx” represents the number of the program.
- 5 Perform tasks.**
- 6 End the program by entering

 - 7 Always end the log in session with
LOGO
Background routines are then loaded automatically.

Access through the maintenance telephone.

A telephone set functions as a maintenance telephone when you **define** the class-of-service as MTA (maintenance set allowed) in the SL-1 Telephone Sets program (LD 11). A maintenance telephone allows you to send commands to the system, but you can only use a subset of the commands that can be entered from a system terminal. The maintenance telephone, however, takes priority over a system terminal and will log the terminal out.

You can test tones and outpulsing through the maintenance telephone. Specific commands for those tests are given in the Tone and Digit Switch and **Digitone** Receiver Diagnostic (LD 34).

No log in procedure is required when you access the system through a maintenance telephone (see Procedure 2). To enter commands, press the keys that correspond to the letters and numbers of the command (for example, to enter **LD 42** return, key in **53#42##**). Table 1 shows the translation from a terminal keyboard to a telephone dial pad.

Note: To use the maintenance telephone, the Peripheral Equipment loop for that telephone must be operating.

Table 1
Translation from keyboard to dial pad

Keyboard			Dial pad
			1
A	B	C	2
D	E	F	3
G	H	I	4
J	K	L	5
M	N	O	6
P	R	S	7
T	U	V	8
w	x	Y	9
			0
		Space of #	#
		Return	##

Note: There is no equivalent for **Q** or **Z** on a dial pad.

Procedure 2
Accessing the maintenance telephone

- 1 Press the prime DN key.
- 2 Place the set in maintenance mode by entering
xxxx91
“xxxx” represents the customer Special Prefix (**SPRE**) number. It is defined in the Customer Data Block and can be printed using LD 21. The SPRE number is typically “1” (which means you would enter 191).
- 3 Check for busy tone by entering

 - If there is no busy tone, go to Step 4.
 - If there is a busy tone, a program is active. To end an active program and access the system, enter

- 4 Load a program by entering
53#xx##
“xx” represents the number of the program.
- 5 Perform tasks.
- 6 Press the release key to return the set to call processing mode. Background routines are then loaded automatically.



Replacing equipment

Chapter contents

Removing UEM covers	11
Removing UEM covers	11
A0367754 Top Cap Fan (system option 21 A)	12
NT6D3903 CPU/Network Card Cage Assembly	16
NT6D40AA, NT6D41AA, NT7D03AA, NT7D04AA Power Supply DC	22
NT6D52AA Rectifier	24
NT7D1 OAA Power Distribution Unit DC	26
NT7D14AA, NT8D06AA, NT8D21AA, NT8D29AA Power Supply AC	30
NT7D15AA System Monitor (system option 21 A)	32
NT7D17AC and NT7D17DC Fan Unit	34
NT8D01 AC and NT8D01AD Controller Card	36
NT8D02AA, NT8D03AA, NT8D09AA, NT8D14AA, NT8D15AA, NT8D16AA, QPC353, QPC397, QPC430, QPC432 Peripheral Equipment Card	38
NT8D04AA Superloop Network Card and QPC414 Network Card	40
NT8D17AA Conference/TDS Card	42
NT8D18AA Network/DTR Card	44
NT8D19AA Memory/Peripheral Signaling Card	46
NT8D22AB System Monitor	48
NT8D39AA Power Fail Transfer Unit	50
NT8D41 AA Serial Data Interface paddle board	52
NT8D46AC and NT8D46DC Thermostat Harness	54
NT8D46AM Air Probe Harness	62
NT8D52AA and NT8D52DC Blower Unit	66

10 Replacing equipment

NT8D53AB Power Distribution Unit AC	68
NT8D53AD Power Distribution Unit (system option 21A)	72
NT8D56AA, NT8D56AC, NT8D57AA Module Power Distribution Unit	76
NT8D68AA Floppy Disk Unit	80
NT8D69AA Multi Disk Unit	82
NT8D1103 Common/Peripheral Equipment Card Cage Assembly	84
NT8D1303 Peripheral Equipment Card Cage Assembly	88
NT8D3403 CPU Card Cage Assembly	92
NT8D3503 Network Card Cage Assembly	96
NT8D3703 Intelligent Peripheral Equipment Card Cage Assembly	102
QMM42 Data Cartridge	106
QPC43 Peripheral Signaling Card	108
QPC215 Segmented Bus Extender Card and QPC441 Three Port Extender Card	110
QPC412 InterGroup Switch Card	114
QPC471 and QPC775 Clock Controller Card	116
QPC477 Bus Terminating Unit	120
QPC513 and QPC841 Serial Data Interface Card	122
QPC579 CPU Function Card	124
QPC580 CPU Interface Card	126
QPC581 Changeover and Memory Arbitrator Card	128
QPC583 Memory Card	130
QPC584 Mass Storage Interface Card and QPC742 Floppy Disk Interface Card	132
QPC659 Dual Loop Peripheral Buffer Card	134
QPC687 CPU Card	136
QPC939 Read Only Memory Card	138
QPC940 Read Only Memory Card	140

Removing UEM covers

To remove the covers on a Universal Equipment Module (**UEM**), you must turn the two locking latches counterclockwise with a standard screwdriver, push the sliding latches toward the center of the cover, **and** pull the cover towards you while lifting it away from the UEM. Figure 1 shows the location of the locking latches.

Figure 1
Locking latches on the UEM cover

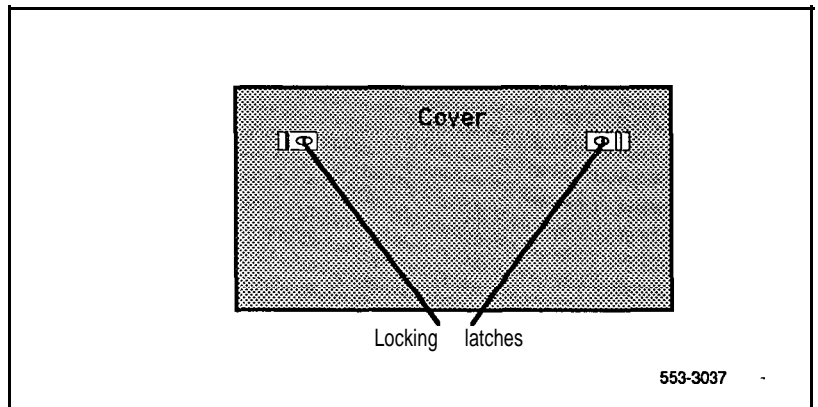

WARNING

r UEM covers are *not* hinged, do *not* let go of the cover. Lift the cover away from the UEM and set it out of your work area.

A0367754 Top Cap Fan (system option 21A)‘

Use this procedure to replace the Top Cap Fan used in system option 21A.

See *the X11 input/output guide (553-3001-400)* for a description of all maintenance commands and system messages.

WARNING

UEM covers are *not* hinged; do *not* let go of the cover. Lift the cover away from the UEM and set it out of your work area.

Removing equipment

- 1 Disconnect power to the Top Cap Fan:
 - Remove the back cover on the UEM.
 - Remove **the** backplane access plate on **the** I/O assembly.

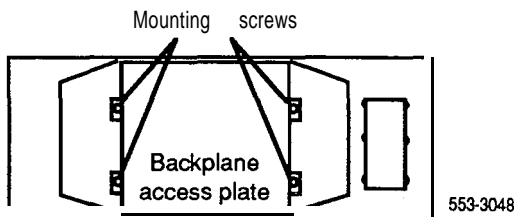

- At the top of the back of the UEM, disconnect the orange plug connector from the UEM power harness.
- 2 Remove the Top Cap:
 - Remove air exhaust grills at the front and back of the Top Cap. Pull forward on the two clips underneath the front edge of each grill to remove the grill.

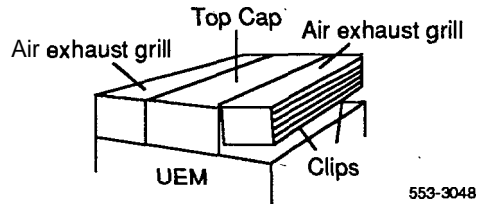

- Use a **5/16"** socket wrench to remove the six screws that secure the Top Cap (see Figure 2). Lift off the Top Cap only.

Note: You do not need to remove the top perforated panel.

3 Remove the Top Cap Fan:

- Remove the four corner screws that secure the fan and the metal cover plate on top of the fan. Keep the cover plate handy; you will use it with the replacement fan.
- Disconnect the black fan cord from the plug on the front of the fan.

Installing equipment

4 Install the replacement Top Cap Fan:

- Position the fan. The Air Flow arrow must point up, and the fan cord plug must face **the front** of the UEM.
- Connect the black fan cord to the plug on the front of the fan.
- Place the cover plate on top of the fan. Install the four corner screws that secure the fan and cover plate.

5 Install the Top Cap:

- Position the Top Cap and install the six screws that secure it.
- Install the air exhaust grills at the front and back of the Top Cap.

— continued —

A0367754 Top Cap Fan (continued)

- 6 Connect power to the Top Cap Fan:
 - At the top of the back of the UEM, connect the orange plug connector to the UEM power harness.
 - Replace the backplane access plate on the I/O assembly.
 - Replace the back cover on the UEM.
- 7 Tag defective equipment with a description of the problem and package it for return to a repair center.



Figure 2
Top cap assembly

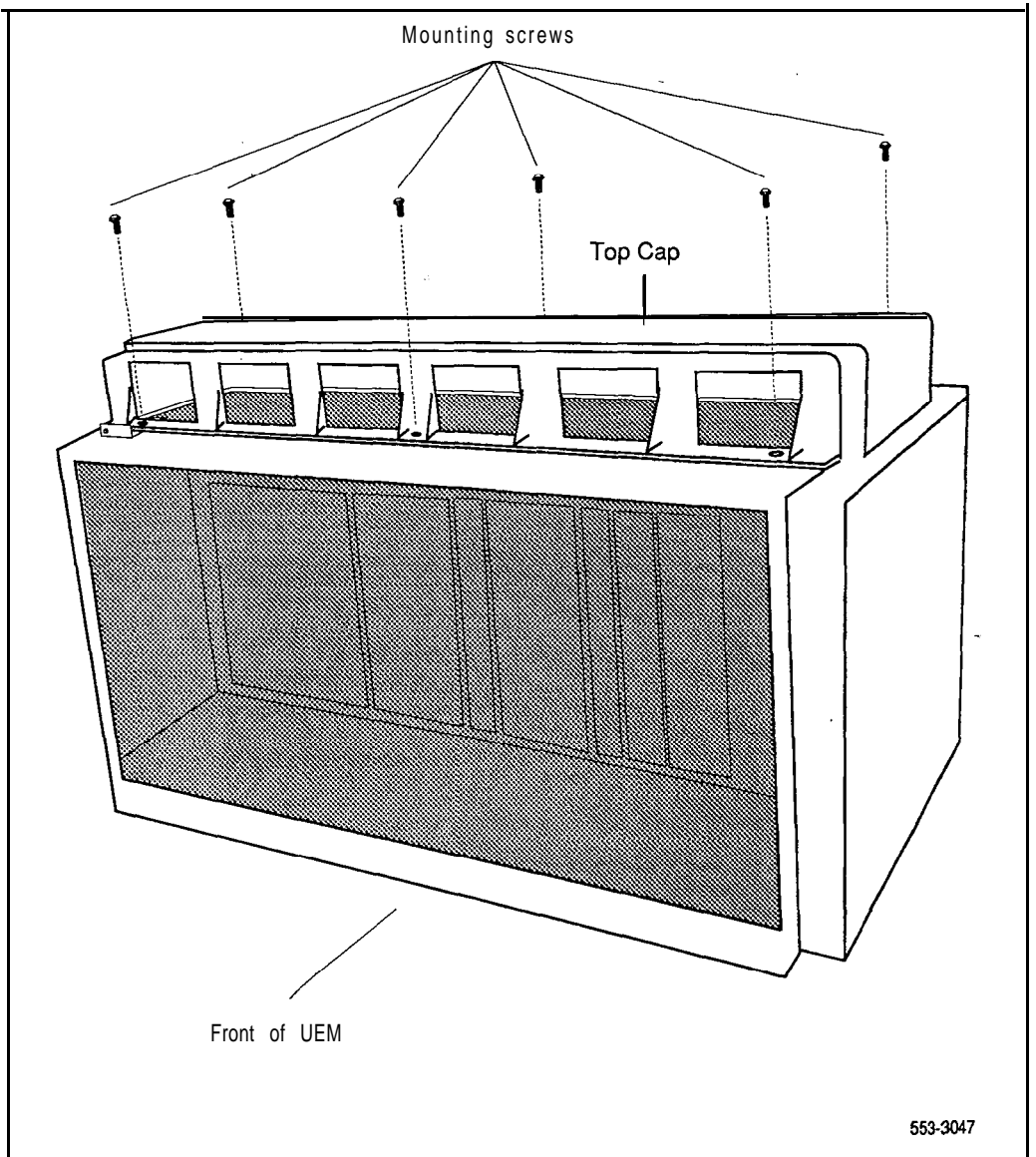

NT6D3903 CPU/Network Card Cage Assembly

To replace a defective **NT6D3901** CPU/Network Backplane, you must replace the **NT6D3903** CPU/Network Card Cage Assembly. Use this procedure to replace the unit.

See the XII input/output guide (**553-3001-400**) for a description of all maintenance commands and system messages.

WARNING

UEM covers are *not* hinged; do *not* let go of the cover. Lift the cover away from the UEM and set it out of your work area.

Removing equipment

- 1 Disable the CPU:
 - In a single CPU system, set the **ENB/DIS** switch to **DIS** on the **QPC580 CPU Interface (IF)** Card.
 - In a dual CPU system, **the** CPU on the backplane you are replacing must be inactive:

If you need to switch CPUs, enter

LD 35
SCPU

End the session in LD 35 by entering

Set the **NORM/MAINT** switch to **MAINT** on the *active* CPU Interface (IF') Card. (This keeps the system from switching to the inactive CPU.)

Set the **ENB/DIS** switch to **DIS** on the *inactive* Interface Card.

2 Software disable Network Equipment cards:

- Disable all network loops on the shelf by disabling the Peripheral Signaling Card. Enter

LD 32**DSPS x**

(Table 3 lists the loops represented by "x")

End the session in LD 32 by entering

- Disable all other cards that might be in the UEM, such as Serial Data Interface (SDI) Cards or Primary Rate Interface (**PRI**) Cards.

Table 3
Network loop codes

Group/ shelf	Peripheral signaling card	Loops disabled/enabled
0/0	0	0 — 15
0/1	1	16 — 31
1/0	2	32 — 47
1/1	3	48 — 63
2/0	4	64 — 79
2/1	5	80 - 9 5
3/0	6	96 — 111
3/1	7	112 — 127
4/0	8	128 — 143
4/1	9	144 — 159

- 3 If the Multi Disk Unit (MDU) or Floppy Disk Unit (FDU) is located in the UEM, unseat disks from the disk drives.

-continued —

NT6D3903 CPU/Network Card Cage Assembly (continued)

- 4 Turn off power to the UEM power supply:
 - With AC power, set the circuit breaker on the NT8D56AA Module Power Distribution Unit (MPDU) to OFF (down).
 - With DC power, set the switch on the NT8D29AA Common Equipment Power Supply to OFF (down).
- 5 Remove all cards from the UEM:
 - Tag and disconnect cables to all faceplate connectors.
 - Tag cards so they can be returned to the same slot. Remove cards.
- 6 Disconnect cables, plugs, and wires from the back of the UEM to the backplane:

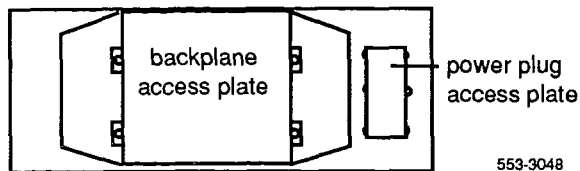

- Remove the backplane access plate by turning the screws on each side. Set the plate aside.
 - Tag and disconnect all cables from the backplane to the interior of the I/O assembly.
 - Remove the power plug access plate by turning the screws on each side. Set the plate aside.
 - Tag and disconnect all plugs, wires, and cables to the backplane.
- 7 Remove the two mounting screws that secure the back of the card cage to the UEM assembly.
 - 8 Remove the front cover plates on both sides of the card cage.
 - 9 Remove the three mounting screws that secure the front of the card cage to the bottom of the UEM assembly. Pull the card cage out of the UEM.

Installing equipment

- 10 Slide the replacement card cage into position in the UEM. Install the mounting **screws** at the front of the card cage.
- 11 Replace the front cover plates on both sides of the card cage.
- 12 Install the mounting screws at the back of the card cage.
- 13 Reconnect cables, plugs, and wires to the backplane:
 - Connect all cables from the interior of the I/O assembly to the backplane.
 - Position the backplane access plate. Tighten the screws.
 - Connect all plugs, wires, and cables to the backplane.
 - Position the power plug access plate. Tighten the screws.
- 14 Return cards to their slots. Reconnect all cables to connectors.
- 15 Turn on power to the UEM power supply:
 - With AC power, set the MPDU circuit breaker to ON (up).
 - With DC power, set the power supply switch to ON (up).
- 16 If the MDU or FDU is in the UEM, reinsert disks into the drive.
- 17 Enable the CPU:
 - Set the **ENB/DIS** switch to ENB on the inactive Interface Card.
 - In a dual CPU system, set the **NORM/MAINT** switch to NORM on both Interface Cards.
- 18 Software enable Network Equipment cards:
 - Enable the Peripheral Signaling Card by entering
LD 32
ENPS x

End the session in LD 32 by entering

 - Enable any other disabled cards.

-continued -

NT6D3903 CPU/Network Card Cage Assembly (continued)

- 19 Test network loops by entering
LD30
LOOP all
- If there is a problem, an NWS system message will be generated.
 - End the session in LD 30 by entering

- 20 Tag defective equipment with a description of the problem and package it for return to a repair center.

NT6D40AA, NT6D41 AA, NT7D03AA, NT7D04AA Power Supply DC

Use this procedure to replace:

- NT6D40AA Peripheral Equipment Power Supply DC
- NT6D41AA Common Equipment Power Supply DC
- NT7D03AA Ringing Generator DC
- NT7D04AA Common/Peripheral Equipment Power Supply DC

See the *X11 input/output guide (553-3001-400)* for a description of all maintenance commands and system messages.

WARNING

UEM covers are *not* hinged; do *not* let go of the cover. Lift the cover away from the UEM and set it out of your work area.

Removing equipment

- 1 Set the switch on the front of the power supply to OFF (down).
- 2 Unhook the locking devices on the power supply; pull it out of the card cage.

installing equipment

- 3 Set the switch on the replacement power supply to **OFF** (down).

Note: On a replacement NT7D03AA or NT7D04AA, set option switches the same as on the one you removed. To check switch settings, see *Circuit puck installation and testing (553-3001-211)*.

- 4 Insert the replacement power supply into the vacated slot and hook the locking devices.

- 5 Set the switch on the replacement power supply to ON (up). The green LED on the power supply should light and stay lit.
- 6 Tag defective equipment with a description of the problem and package it for return to a repair center.

NT6D52AA Rectifier

Use **this** procedure to replace **NT6D52AA** Rectifiers.

Removing equipment

- 1 Remove the back panel from the rectifier and open the front cover on the **QBL15** Power/Battery Distribution Box.
- 2 Tag and disconnect all wiring from the battery box to the rectifier.
- 3 Remove **the** screws that position the rectifier in the rectifier rack. Lift the rectifier out of **the** rack.

Installing equipment

- 4 Position **the** replacement rectifier in the rack. Replace all screws.
- 5 Remove the back panel from the replacement rectifier.
- 6 Connect wiring from the **QBL15 Power/Battery** Distribution Box to the **NT6D52AA** Rectifier as follows (see Figure 3):
 - Connect one (or two if required) 4 AWG black wire from terminal 2 (**+48V**) on TB3 in the rectifier to the +VE BUS in the battery distribution box.
 - Connect one (or two if required) 4 AWG red wire from terminal 1 (-48V) on TB3 in **the** rectifier to CHARGE 1, 2, or 3 (terminal 9, 10, or 11) on **TB1** in the battery distribution box.
 - Connect a 22 AWG black wire from terminal 2 (**+SENSE**) on TB4 in the rectifier to terminal 1, 3, or 5 (**+SENSE**) on TB3 in the battery distribution box.
 - Connect a 22 AWG red wire from terminal 3 (**-SENSE**) on TB4 in the rectifier to terminal 2, 4, or 6 (**-SENSE**) on TB3 in the battery distribution box.
 - Connect a 22 AWG blue wire from terminal 5 (**DCON**) on TB4 in the rectifier to terminal 1, 2, 3, or 4 (**@CON**) on TB2 in the battery distribution box.
- 7 Install the back panel on the replacement rectifier and close the front cover on the battery distribution box.

Figure 3
NT6D52AA Rectifier and QBL15 Power/Battery Distribution Box connections

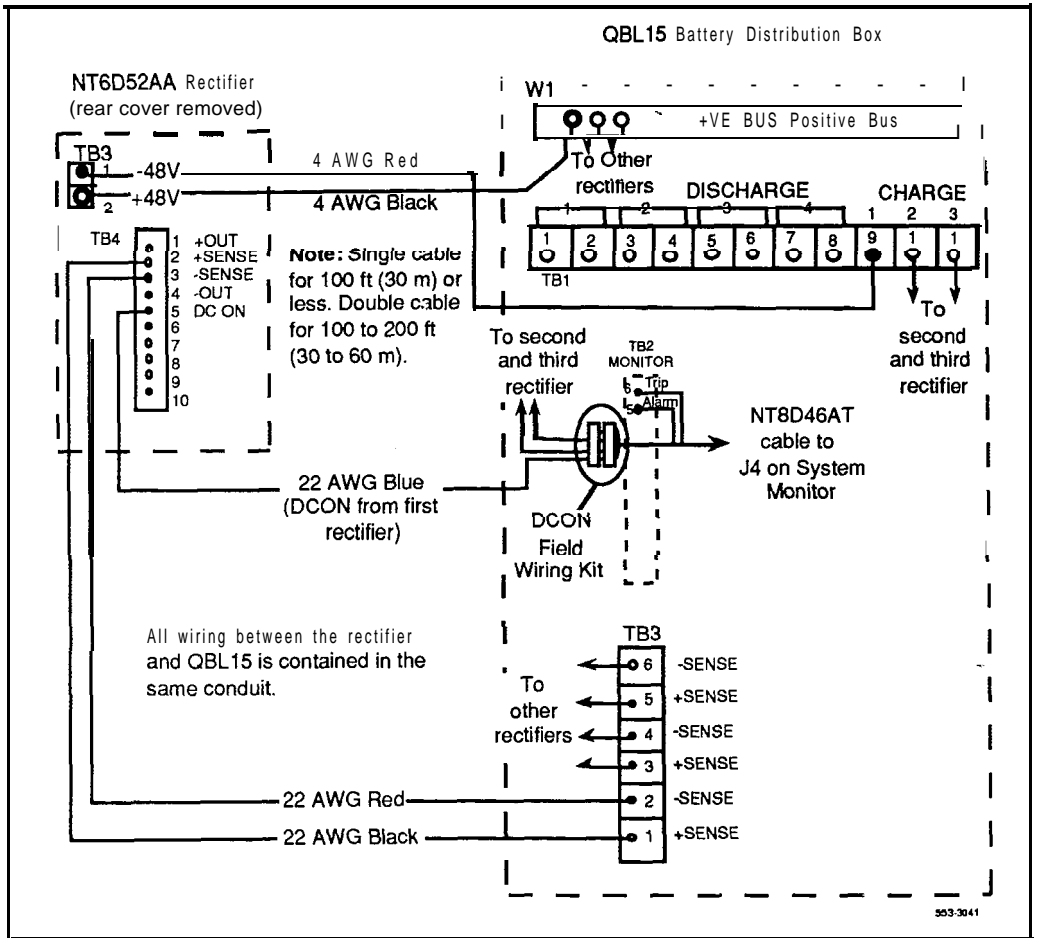

NT7D10AA Power Distribution-Unit DC

Use this procedure to replace a Power Distribution Unit (PDU) DC. Figure 4 shows the location of the PDU in the pedestal.

See the *XII input/output* guide (553-3001-400) for a description of all maintenance commands and system messages.

WARNING

UEM covers are *not* hinged; do *not* let go of the cover. Lift the cover away from the **UEM** and set it out of your work area.

Removing equipment

- 1 Disconnect the source of DC power.
- 2 Remove the grill on the back of the pedestal.
- 3 Disconnect cables to the UEM above the pedestal (UEM 0):
 - Remove the back cover on UEM 0.
 - Remove the backplane access plate on the I/O assembly.

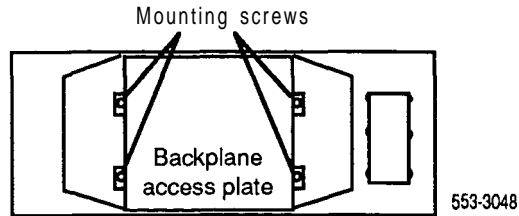

- Disconnect the power plug (J1) and System Monitor ribbon cable to UEM 0.

Note: To disconnect the power plug, you must press a latch trip on the front and back of the plug. You may need to use a screwdriver blade against the latch trip on the front of the plug.

- 4 Tag and disconnect cables to the **NT8D22AB** System Monitor. Loosen the two screws on the System Monitor. Remove the card.

- 5 Unseat **the** Fan or Blower Unit in the front of the pedestal:
 - Remove the grill on the front of the pedestal. Turn off power to the unit:
 - With AC power, set the circuit breaker on the front of **the** unit to OFF (down).
 - With DC power, set the toggle switch on the front of the unit to OFF (down).
 - Turn **the** screws on the front of the unit counter-clockwise and pull the unit forward several inches.
- 6 Remove the six screws that position the PDU. Carefully pull the unit straight forward and set it in front of **the** pedestal.

CAUTION

The PDU cannot be completely removed from **the** pedestal until the field wiring terminal is disconnected.

- 7 Tag and disconnect all wiring to the front of the field wiring terminal.

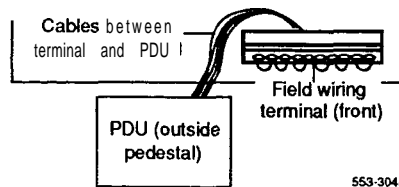
**CAUTION**

Label wires carefully. They must be reconnected correctly or the system may be damaged.

-continued -

NT7D10AA Power Distribution Unit DC (continued)

- 8 Remove the field wiring terminal:
 - Remove the cover over the terminal.
 - Remove the four screws that position the terminal and lift the terminal out of the pedestal.

Installing equipment

- 9 Set all five circuit breakers on the replacement PDU to OFF (down).
- 10 Install the replacement field wiring terminal:
 - Position the terminal and replace the screws.
 - Replace the cover over the terminal.
- 11 Connect all wiring to the field wiring terminal.
- 12 Position the replacement PDU and **gently** push it into the pedestal. Replace the screws on the PDU.

Note: Be sure you push the unit straight back, so the connector on the back will seat properly with the Fan or Blower Unit connector.

- 13 Reseat the Fan or Blower Unit:
 - Lift the unit slightly and slide it into the pedestal glides. Turn on power to the unit by setting the circuit breaker or toggle switch to **ON (up)**.
 - Tighten the screws on the front of the unit.
- 14 Reconnect cables to UEM 0:
 - Attach power plug **J1** and the System Monitor cable.
 - Replace the backplane access plate on the I/O assembly.
 - Replace the back cover on the UEM.
- 15 Insert the System Monitor. Tighten the screws on the card. Reconnect cables to the System Monitor faceplate.
- 16 Set all five circuit breakers on the PDU to ON (up).
- 17 Reconnect the source of DC power.

- 18 Replace the pedestal grill.
- 19 Tag defective equipment with a description of the problem and package it for return to a repair center.

Figure 4
Power Distribution Unit DC in the pedestal

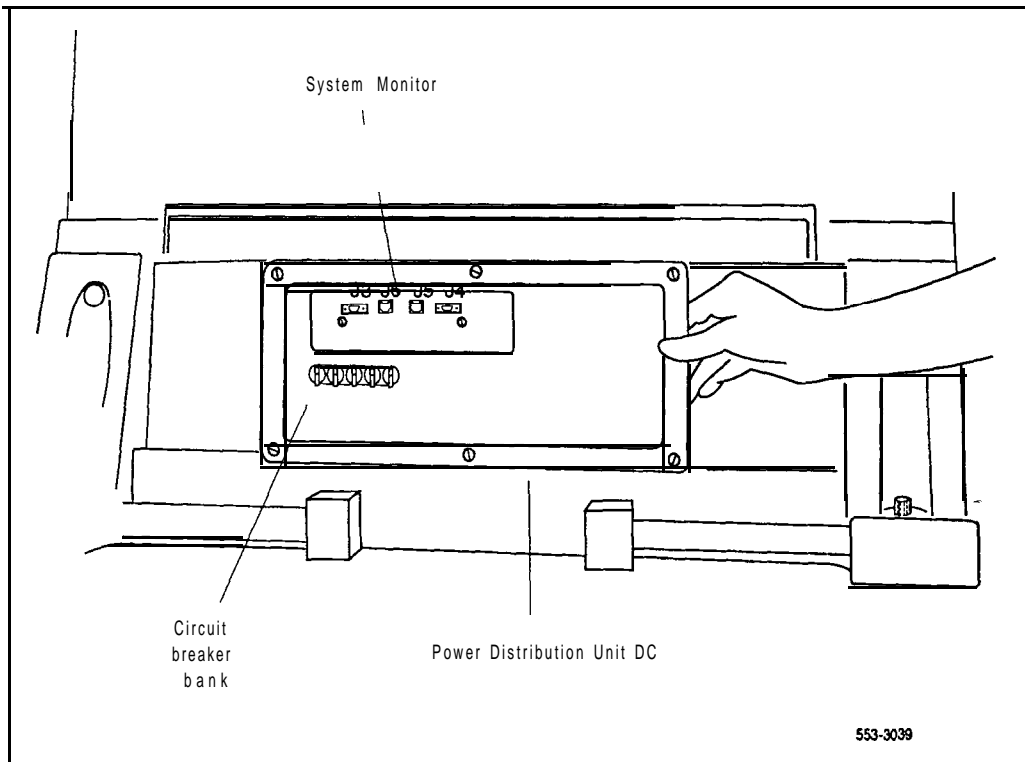

NT7D14AA, NT8D06AA, NT8D21 AA, NT8D29AA Power Supply AC

Use this procedure to replace:

- NT7D14AA Common/Peripheral Equipment Power Supply AC
- NT8D06AA Peripheral Equipment Power Supply AC
- NT8D21AA Ringing Generator AC
- NT8D29AA Common Equipment Power Supply AC

See the *X11 input/output guide* (553-3001-400) for a description of all maintenance commands and system messages.

WARNING

UEM covers are *not* hinged; do not let go of the cover. Lift the cover away from the UEM and set it out of your work area.

Removing equipment

- 1 Turn off power to the UEM power supply:
 - If there is a Module Power Distribution Unit (MPDU), set the circuit breaker(s) on the associated MPDU to OFF (down).

Note: If there are two circuit breakers on the MPDU, the top one is associated with the left-hand power supply, the bottom one with the right-hand power supply (see Figure 5).
 - If there is no MPDU, set **the** switch on the power supply faceplate to OFF (down).
- 2 Unhook the locking devices on the power supply. Wait at least five minutes, then pull the power supply out of the card cage.

CAUTION

Power must discharge. **Wait five full minutes** before you remove the power supply from the UEM.

Installing equipment

- 3 Insert the replacement power supply into the vacated slot and hook the locking devices.

Note: If there is a switch on the power supply, set the switch to OFF (down) before you insert the power supply

Note: On a replacement **NT8D21AA**, set option switches the same as on the one you removed. To check switch settings, **see Circuit pack installation and testing (553-3001-211)**.

- 4 Turn on power to the UEM power supply. The green LED on the power supply should light and stay lit.
 - If there is an MPDU, set the circuit breaker(s) to ON (up).
 - If there is no MPDU, set the power supply switch to ON (up).
- 5 Tag defective equipment with a description of the problem and package it for return to a repair center.

Figure 5
Dual circuit breaker and associated UEM power supplies

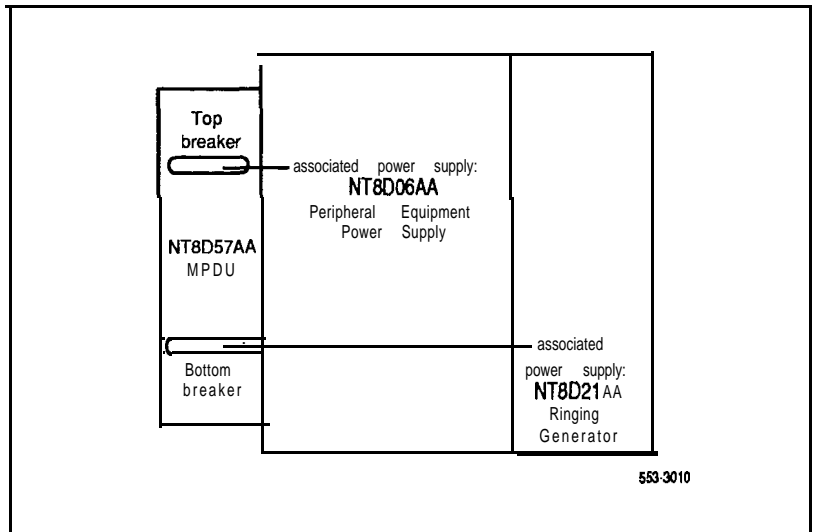

NT7D15AA System Monitor (system option 21 A)

The **NT7D15AA** System Monitor, used in system option **21A**, attaches to the back of the **NT8D1102** Common/Peripheral Equipment Backplane. Use this procedure to replace the System Monitor.

See the *XII input/output* guide (553-3001-400) for a description of all maintenance commands and system messages.

WARNING

UEM covers are *not* hinged; do *not* let go of the cover. Lift the cover away from the UEM and set it out of your work area.

Removing equipment

- 1 Remove the back cover on the UEM.
- 2 Remove the backplane access plate by turning the screws on each side. Set the plate aside.

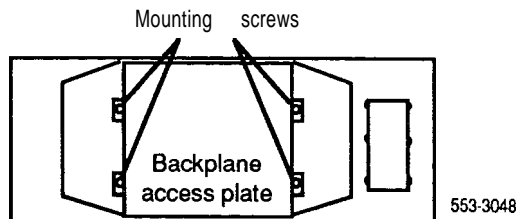

- 3 Tag and disconnect cables to the System Monitor in the following order: disconnect the cable to connector P3, then P2, then P1.

CAUTION

If you do not disconnect and reconnect cables in the order given, the system will shut down.

- 4 Pull the card out of the connector on the backplane.

Installing equipment

- 5 Plug **the** cable to connector **P1** into the replacement card (before you insert the card).
- 6 Plug the replacement card into the bottom of the vacated connector (the connector closet to the right) on the backplane.,
- 7 Connect cables to **connectors** P2 and P3 to the replacement card.
- 8** Replace the backplane access plate.
- 9 Replace the back cover on **the** UEM.
- 10 Tag defective equipment with a description of the problem and package it for return to a repair center.

NT7D17AC and NT7D17DC Fan Unit

Use this procedure to replace a Fan Unit.

See the *XII input/output guide (553-3001-400)* for a description of all maintenance commands and system messages.



Removing equipment

- 1 Gwsp the ridges on the outside upper edges of the front pedestal grill. Pull the grill away from the pedestal. Set the grill aside.
- 2 Turn off power to the Fan Unit:
 - With AC power, set the circuit breaker on the front of the unit to OFF (down).
 - With DC power, set the toggle switch on the front of the unit to OFF (down).
- 3 Loosen the two screws on the front of the Fan Unit by turning them counter-clockwise.
- 4 Grasp the tabs at each side of the Fan Unit. Slide the unit out of the glides. Lift the unit out of the pedestal.

Note: Store the Fan Unit in an upright position at all times.

installing equipment

- 5 Set the replacement Fan Unit on the bottom ledge of the pedestal.
- 6 Lift the Fan Unit so it will slide into the pedestal glides. Gently push the unit into position.
- 7 Tighten the front screws.
- 8 Turn on power to the Fan Unit:
 - With AC power, set the circuit breaker to ON (up).
 - With DC power, set the toggle switch to ON (up).



- 9 Fit the grill into the holes in the bottom ledge of the pedestal. Push the grill back into a locked position.
- 10 Tag defective equipment with a description of the problem and package it for return to a repair center.

NT8D01AC and NT8D01AD Controller Card

Use this procedure to replace an **NT8D01** AC Controller Card-4 or an **NT8D01AD** Controller Card-2.

See the *XII input/output guide* (553-3001-400) for a description of all maintenance commands and system messages.

WARNING

UEM covers are *not* hinged; do *not* let go of the cover. Lift the cover away from the **UEM** and set it out of your work area.

Removing equipment

- 1 Software disable the Controller Card (and all cards connected to the Controller) by entering
LD 32
DSXP x
("x" represents the card number)
- 2 Unhook the locking devices on the card; pull it out of the card cage.

Installing equipment

- 3 Insert the replacement card into the vacated slot and hook the locking devices. The Controller Card will run a series of self tests:
 - During the tests, the maintenance display on the card shows the code for each test running (see "HEX" in the *XII input/output guide*). If the tests complete successfully, the display begins normal operation. If the card continuously fails a test, the code for that test is displayed.
 - If the tests complete successfully, the LED on the card flashes three times, the card is automatically enabled (if it is configured in software), and the LED goes out. If the card fails the tests, the LED lights steadily and remains lit.

- 4 Software enable and test the **Controller** Card (and all cards connected to the Controller) by entering
ENXP x
 - If there is a problem, an **NPR**, **NWS**, or **SDL** system message may be produced and the red LED will light on the Controller Card.
 - End the session in LD 32 by entering

- 5 Tag defective equipment with a description of the problem and package it for return to a repair center.

NT8D02AA, NT8D03AA, NT8D09AA, NT8D14AA, NT8D15AA, NT8D16AA, QPC353, QPC397, QPC430, QPC432 Peripheral Equipment Card

Use this procedure to replace the following Peripheral Equipment (PE) cards:

- NT8D02AA Digital Line Card
- NT8D03AA Analog Line Card
- NT8D09AA Analog Message Waiting Line Card
- NT8D14AA Universal Trunk Card
- NT8D15AA E&M Trunk Card
- NT8D 16AA Digitone Receiver Card
- QPC353 Modem Pool Line Card
- QPC397 Asynchronous Interface Line Card
- QPC430 Asynchronous Interface Line Card
- QPC432 Four Port Digital Line Card

See the *X11* input/output **guide** (553-3001-400) for a description of all maintenance commands and system messages.

WARNING

UEM covers are not hinged; do not let go of the cover. Lift the cover away from the UEM and set it out of your work area.

Removing equipment

- 1 Software disable the card by entering

LD 32

DISI s c

("1 s c" represents loop, shelf, and card number)

You will see "NPR01 1" on the system terminal when the card is disabled. Busy channels will not be disabled until the call is disconnected.

- 2 Unhook the locking devices on the card; pull it out of the card cage.

Installing equipment

- 3 Set option switches or jumper plugs on the following replacement cards the same as on the card you removed:

QPC432 Four Port Digital Line Card

NT8D 14AA Universal Trunk Card

NT8D15AA E&M Trunk Card

To check settings, see ***Circuit pack installation and testing*** (553-3001-211).

- 4 Insert the replacement card into the vacated slot and hook the locking devices.

Note: When Intelligent Peripheral Equipment Cards are installed, the red LED on the faceplate flashes as a self test runs. If the self test completes successfully, the card is automatically enabled (if it is configured in software) and the LED goes out. If the self test fails, the LED lights steadily and remains lit.

- 5 Software enable the card by entering
ENLC Isc

- When the process is complete, you will receive a system response.
- End the session in LD 32 by entering

- 6 Test the card by entering:
LD 30
SHLF 1 s

Note: This command tests every card on the designated shelf.

- If there is a problem, an NPR system message will be generated and the red LED(s) on the faceplate of the card will remain lit.
- End the session in LD 30 by entering

- 7 Tag defective equipment with a description of the problem and package it for return to a repair center.

NT8D04AA Super-loop Network Card and QPC414 Network Card

Use this procedure to replace a Superloop Network Card or Network Card.

See the *XII input/output* guide (553-3001-400) for a description of all maintenance commands and system messages.

WARNING

UEM covers are *not* hinged; do *not* let go of the cover. Lift the cover away from the UEM and set it out of your work area.

CAUTION

All services on a loop are interrupted while the loop is disabled.

Removing equipment

- 1 Check the status of each loop on the Superloop Network Card or Network Card by entering
LD 32
STAT loop
("loop" represents a loop number)
 - If the response is DSBL for all loops, go to Step 2.
 - If there are responses other than DSBL, see "LD32" in the *XI I input/output guide* for an interpretation.
- 2 Set the ENB/DIS switch to DIS.

CAUTION

To avoid interrupting service, set ENB/DIS switches to DIS before disconnecting or connecting cables.

- 3 Tag and disconnect cables to the card you are removing.
- 4 Unhook the locking devices on the card pull it out of the card cage.

Installing equipment

- 5 Set the ENB/DIS switch to DIS on the replacement card.

Note: On a replacement QPC4 14, set option switches and jumper plugs the same as on the card you removed. To check switch settings, *see Circuit pack installation and testing (553-3001-211)*.
- 6 Insert the replacement card into the vacated slot and hook the locking devices.
- 7 Connect cables to the replacement card.
- 8 Set the ENB/DIS switch to ENB on the replacement card.
- 9 Software enable each loop on the card by entering **ENLL loop**
 - When the process is complete, you will receive a system response.
 - The card is tested automatically when all loops are enabled.
 - If there is a problem, an NWS system message will be generated and the red LED on the faceplate of the card will flash (on the NT8D04AA) or be steadily lit (on the QPC414).
 - End the session in LD 32 by entering

- 10 Tag defective equipment with a description of the problem and package it for return to a repair center.

NT8D17AA Conference/TDS Card

The **Conference/TDS** Card provides Conference functions on one port and both Tone and Digit Switch (TDS) and Multifrequency Sender (**MFS**) functions on a second port. Use this procedure to replace a **Conference/TDS** Card.

See the XII *input/output* guide (553-3001-400) for a description of all maintenance commands and system messages.

WARNING

UEM covers are not hinged; do not let go of the cover. Lift the cover away from the UEM and set it out of your work area.

Removing equipment

- 1 Software disable the **Conference/TDS** Card by entering **LD 34 or LD 38 or LD 46 DISX loop**
(In LD 38 “loop” represents the Conference loop, which is the odd loop of the **Conference/TDS** loop pair. In LD 34 and LD 46 “loop” represents the **TDS/MFS** loop, which is the even loop of the **Conference/TDS** loop pair.)

Note: You must use the command DISX to disable both loops and all hardware functions. Disabling loops with the command DISL prevents software from using the loops but does not disable the hardware.

- 2 Set the **ENB/DIS** switch to DIS.
- 3 Unhook the locking devices on the card; pull it out of the card cage.

Installing equipment

- 4 Set the **ENB/DIS** switch to DIS on the replacement card.

- 5 Set option switches on the replacement card the same as on the card you removed. To check settings, **see *Circuit pack installation and testing*** (553-3001-211).
- 6 Insert the replacement card into the vacated slot and hook the locking devices. Both red **LEDs** should flash three times and remain lit if the card is good.
- 7 Set the **ENB/DIS** switch to ENB on the replacement card.
- 8 Software enable the card by entering
ENLX loop
This prompt is available in LD 34, LD 38, and LD 46. Use the appropriate loop number (see Step 1).

Note: You must enable the card with the command ENLX. Enabling the loops with the command ENLL does not enable the hardware.

- 9 Test each loop on the card (when each test completes, enter *****):
 - Test **TDS** capability by entering
LD 34
TDS loop
("loop" will be an even loop number)
 - Test **Conference** capability by entering
LD 38
CNFC loop
("loop" will be an odd loop number)
 - Test **MFS** capability by entering
LD 46
MFS loop
("loop" will be an even loop number)

If there is a problem, a TDS, CNF, or MFS system message will be generated and the appropriate red LED will light on the card faceplate.

- 10 Tag defective equipment with a description of the problem and package it for return to a repair center.

NT8D18AA NetworWDTR Card

The **Network/DTR** Card provides Network and Peripheral Controller functions along with **Digitone** Receiver capability. Use this procedure to replace a **Network/DTR** Card.

See the *X11 input/output guide* (553-3001-400) for a description of all maintenance commands and system messages.

WARNING

UEM covers are **not** hinged; do **not** let go of the cover. Lift the cover away from the UEM and set it out of your work area.

CAUTION

All services on a loop are interrupted while the loop is disabled.

Removing equipment

- 1 Check the status of the superloop by entering
LD 32
STAT 28
(the superloop must be loops 28-3 1)
 - If the response is **DSBL** for all loops, go to Step 2.
 - If there are responses other **than DSBL**, see "**LD32**" in the **X1 1 input/output guide** for an interpretation.
- 2 Set the **ENB/DIS** switch to **DIS**.
- 3 Unhook the locking devices on the card; pull it out of the card cage.

Installing equipment

- 4 Set the **ENB/DIS** switch to **DIS** on the replacement card.
- 5 Insert the replacement card into the vacated slot and hook the locking devices.
- 6 Set the **ENB/DIS** switch to **ENB** on the replacement card.

- 7 Software enable the **superloop** by entering **ENLL 28**
 - When the process is complete, you will receive a system response.
 - If there is a problem, an NPR system message **will be** generated and the red LED on the faceplate of the card will light.
 - End the session in LD 32 by entering

- 8 Tag defective equipment with a description of the problem and package it for return to a repair center.

NT8D19AA Memory/Peripheral Signaling Card

The Memory/Peripheral Signaling Card provides Memory, Miscellaneous, and Peripheral Signaling functions. Use this procedure to replace a Memory/Peripheral Signaling Card.

See the *X11 input/output guide (553-3001-400)* for a description of all maintenance commands and system messages.

WARNING

UEM covers are **not** hinged, do **not** let go of the cover. Lift the cover away from the **UEM** and set it out of your work area.

- 1** Unhook the locking devices on the Memory/Peripheral Signaling Card; pull it out of the card cage.
- 2** Insert the replacement card into the vacated slot and hook the locking devices.
- 3** Press the reload (reset) button on the QPC687 CPU Card to activate a sysload (system reload).
- 4** Tag defective equipment with a description of the problem and package it for return to a repair center.



NT8D22AB System Monitor

Use this procedure to replace an **NT8D22AB** System Monitor. Figure 6 shows the location of the System Monitor in the pedestal.

See the *XII input/output* guide (553-3001-400) for a description of all maintenance commands and system messages.

Removing equipment

- 1 Remove the grill on the back of the pedestal.
- 2 Tag and disconnect cables to the System Monitor.
- 3 Loosen the two screws on the card and pull it out of the slot.

Note: If a slave is removed, the master considers that slave and all slaves with a higher address as disabled. For example, if the slave designated "XSM 2" is disabled, the master also reports slaves 3, 4, and up as disabled.

Installing equipment

- 4 Set option switches on the replacement card the same as on the card you removed. To check switch settings, **see *Circuit pack installation and*** testing (553-3001-211).
- 5 Insert the replacement card into the vacated slot and tighten the two screws on the front of the card.
- 6 Connect cables to the replacement card.
- 7 Replace the grill on the back of the pedestal.
- 8 Test the System Monitor by entering
LD 37
STAT XSM
 - If a single or master System Monitor was replaced successfully, you will receive system message "**PWR000 XSMC 0 0 0 0.**"
 - If a slave was replaced successfully, you will receive "**PWR053 XSMC x 0 0 0**" ("**x**" represents the System Monitor address).

- If there is a problem with a slave, you will receive system message "PWR013 XSMC x 0 0 0."
 - End the session in LD 37 by entering

- 9 Tag defective equipment **with a description** of the problem and package it **for** return to a repair center.

Figure 6
System Monitor in the pedestal

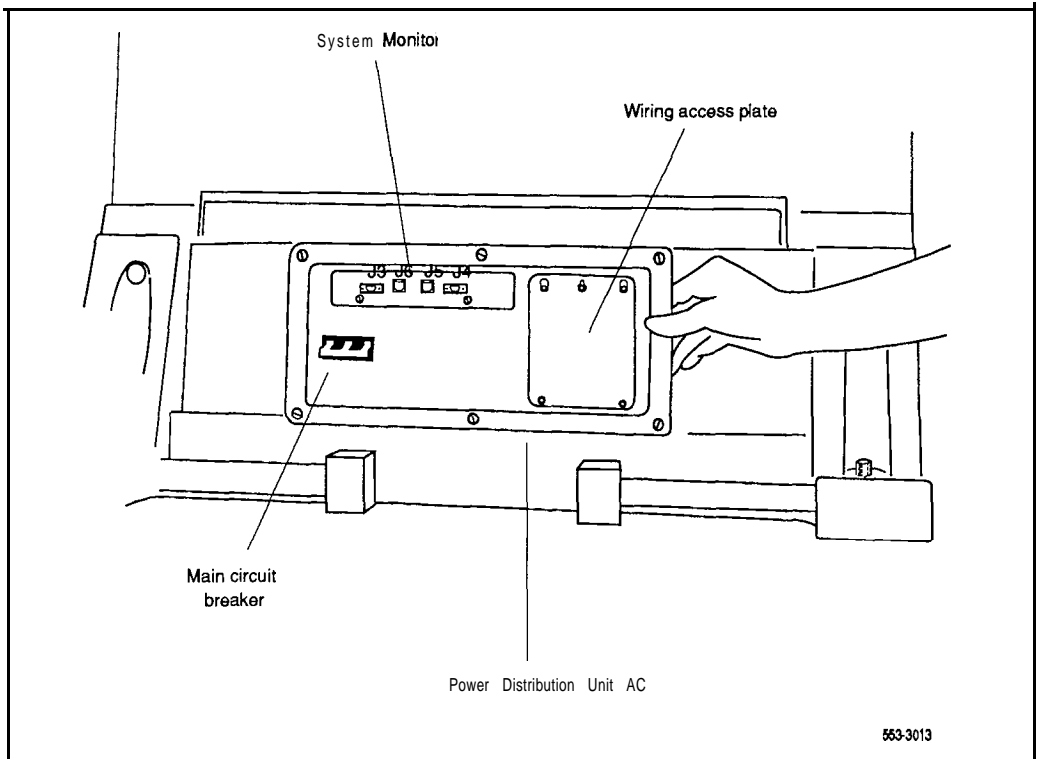

NT8D39AA Power Fail Transfer Unit

Use **this** procedure to replace a Power Fail Transfer Unit (**PFTU**).

- 1 Place temporary jumpers at **the** cross-connect terminal to maintain service on sets connected to the **PFTU** (see Table 2).

Note: Connect **line cord to telephone set (500/2500-type sets)** and **Central Office trunk (CO trunk)** to trunk **card** on each PFT.

- 2 Tag and disconnect cables to the **PFTU**.
- 3 Remove the four mounting screws on the PFTU. Remove the unit and set it aside.
- 4 Attach the replacement **PFTU** with the four mounting screws.
- 5 Connect the cables to the replacement **PFTU**. The LED labeled "POWER" should light and remain lit.
- 6 Remove temporary jumpers at the cross-connect terminal.
- 7 Set the switch on the face of the **PFTU** to OFF (down) for normal operation.
- 8 Tag defective equipment **with** a description of the problem and package it for return to a repair center.

Table 2
PFTU cross connections

Pair	Pin number	Color	PFTU cable 1	PFT	PFTU cable 2	PFT
1T	26	W-BL	To line card	1	To line card	5
1R	1	BL-W				
2T	27	w-o	To telephone set	1	To telephone set	5
2R	2	o-w				
3T	28	W-G	To CO trunk	1	To CO trunk	5
3R	3	G-W				
4T	29	W-BR	To trunk card	1	To trunk card	5
4R	4	BR-W				
5T	30	w-s	To line card	2	To line card	6
5R	5	s-w				
6T	31	R-BL	To telephone set	2	To telephone set	6
6R	6	BL-R				
7T	32	R-O	To CO trunk	2	To CO trunk	6
7R	7	O-R				
8T	33	R-G	To trunk card	2	To trunk card	6
8R	8	G-R				
9T	34	R-BR	To line card	3	To line card	7
9R	9	BR-R				
10T	35	R-S	To telephone set	3	To telephone set	7
10R	10	S-R				
11T	36	BK-BL	To CO trunk	3	To CO trunk	7
11R	11	BL-BK				
12T	37	BK-O	To trunk card	3	To trunk card	7
12R	12	O-BK				
13T	38	BK-G	To line card	4	To line card	8
13R	13	G-BK				
14T	39	BK-BR	To telephone set	4	To telephone set	8
14R	14	BR-BK				
15T	40	BK-S	To CO trunk	4	To CO trunk	8
15R	15	S-BK				
16T	41	Y-BL	To trunk card	4	To trunk card	8
16R	16	BL-Y				

NT8D41AA Serial Data Interface paddle board

The **NT8D41AA** Serial Data Interface (SDI) paddle board attaches to the back of a **Common/Peripheral** Equipment Backplane or CPU/Network Backplane. Use this procedure to replace an **NT8D41AA** Serial Data paddle board.

See the *XII input/output guide (553-3001-400)* for a description of all maintenance commands and system messages.

WARNING

UEM covers are not hinged; do not let go of the cover. Lift the cover away from the UEM and set it out of **your** work area.

CAUTION

If the system terminal is assigned to the **SDI** being replaced, assign it to another port before this **SDI** is disabled.

Removing equipment

- 1 Software disable each port on the Serial Data paddle board by entering LD 37
DIS TTY x
("x" represents the number of the interface device attached to the port)
- 2 Remove the back cover on the UEM.
- 3 Remove the backplane access plate by turning the screws on each side. Set the plate aside.

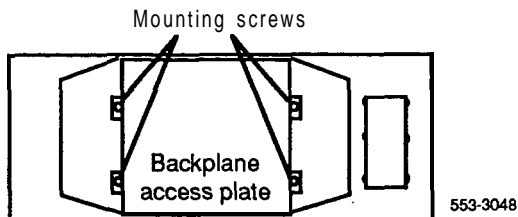

- 4 Set the **ENB/DIS** switch to DIS on **the** paddle board.

CAUTION

To avoid interrupting service, set **ENB/DIS** switches to DIS before disconnecting or connecting cables.

- 5 Tag and disconnect cables to the paddle board you are removing.
- 6 Pull the paddle board out of the connector on the backplane.

Installing equipment

- 7 Set the **ENB/DIS** switch to DIS on the replacement paddle board.
- 8 Set option switches on the replacement paddle board the same as on the board you removed. To check switch settings, *see Circuit pack installation and testing* (553-3001-211).
- 9 Plug the replacement paddle board into the vacated connector on the backplane.
- 10 Connect cables to the replacement paddle board.
- 11 Set the **ENB/DIS** switch to ENB on **the** replacement paddle board.
- 12 Replace the backplane access plate. Replace the back cover on the UEM.
- 13 Software-enable and test each port on the paddle board by entering
ENL TTY x
TTY x
 - If there is a problem, an IOD system message will be generated and the red LED will light on **the** card.
 - End the session in LD 37 by entering

- 14 Tag defective equipment with a description of the problem and package it for return to a repair center.

NT8D46AC and NT8D46DC Thermostat Harness

Use this procedure to replace the Thermostat Harness in the Top Cap of each column.

See the XII *input/output guide* (553-3001-400) for a description of all maintenance commands and system messages.

WARNING

UEM covers are not hinged; do **not** let go of the cover. Lift the cover away from the UEM and set it out of your work area.

Removing equipment

- 1 Disconnect the System Monitor from the circuit breaker system:

Note: For system option **21A**, go to the note in Step 2.

- Remove the grill on the back of the column pedestal.
- Loosen the two screws on the System Monitor and pull it out a few inches.

CAUTION

If the System Monitor is not disconnected, column operation will shut down when the thermostat harness is disconnected.

- 2 Disconnect power to the Top Cap:
 - Remove the back cover on the **UEM** below the Top Cap.
 - Remove the backplane access plate on the I/O assembly.

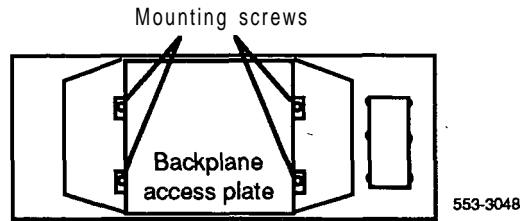

Note: For system option **21A**, disconnect the cable to connector J3 on the **NT7D15AA** System Monitor at this point.

- At the top of the back of the UEM, disconnect the orange plug connector from the UEM power harness.
 - Disconnect the pin headers on connector J2 on the backplane; disconnect the ribbon cable connector.
- 3 Remove the Top Cap:
- Remove air exhaust grills at the front and back of the Top Cap. Pull forward on the two clips underneath the front edge of each grill to remove the grill.

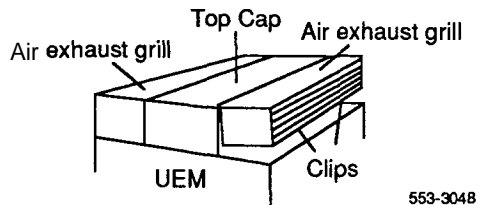

- Use a **5/16"** socket wrench to remove the six screws that secure the Top Cap and perforated panel (see Figure 7). Lift off the Top Cap only.

-continued -

NT8D46AC and NT8D46DC Thermostat Harness (continued)

4 Remove the Thermostat Harness:

Note: The column LED and LED wiring are part of the Thermostat Harness.

- Pull **the** LED ring away from the LED mounting bracket (you may need to loosen it with a standard screwdriver).
- Push the LED back completely out of **the** collar on the LED bracket.
- Remove the LED ring by pulling it forward over the LED. Keep **the** ring handy; you will use it with the replacement equipment.
- Remove the final screw that secures the perforated panel at the LED mounting bracket.

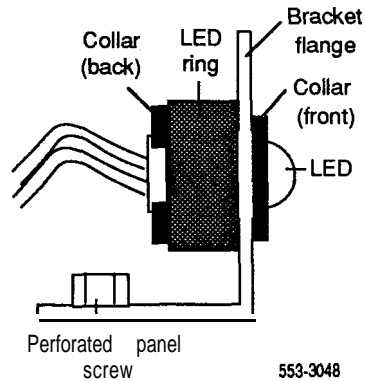

- Slide the perforated panel slightly to the left (looking at it from the back of the column). Lift the panel and turn it over.

- Clip all cable ties that secure the Thermostat wiring. Be careful not to damage other wiring (such as the Air Probe Harness).
- Pull the LED through the rubber grommet at the front of the perforated panel.
- Remove the screws (**two** each) that secure the thermostats. Remove the thermostats and wiring.

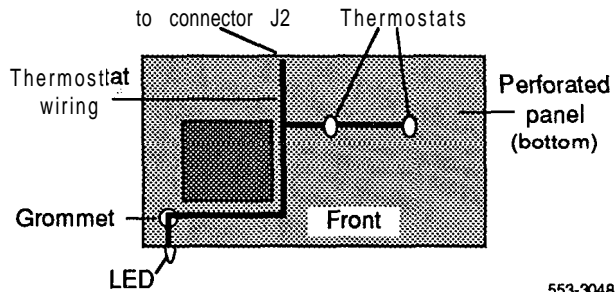

Installing equipment

5 Install the replacement Thermostat Harness:

- Position the replacement thermostats and install the screws.
- Push the LED through the rubber grommet.
- Route the thermostat wiring on the perforated panel. At the back edge of the panel, route the wires with wiring for the Air Probe Harness (or Top Cap Fan in system option 21A). Secure loose wiring to the perforated panel with cable ties.

-continued -

NT8D46AC and NT8D46DC Thermostat Harness (continued)

- Turn the perforated panel over. Slide it slightly to the right (at the back of the column) so it is in a secure position. Position wiring from the perforated panel so it rests in the cable well next to the orange plug connector at the back of the UEM.

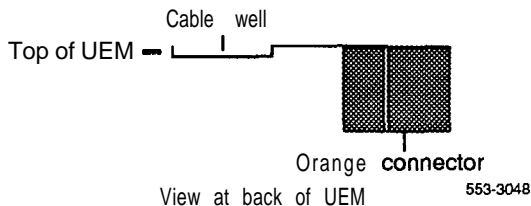

- Position the perforated panel and install the screw that secures it at the LED bracket.
- Slide the LED ring over the LED (it will hang loosely at this point).
- Gently push the LED forward completely through the collar on the LED mounting bracket.
- Push the LED ring into position over the back of the collar and tight against the bracket flange.

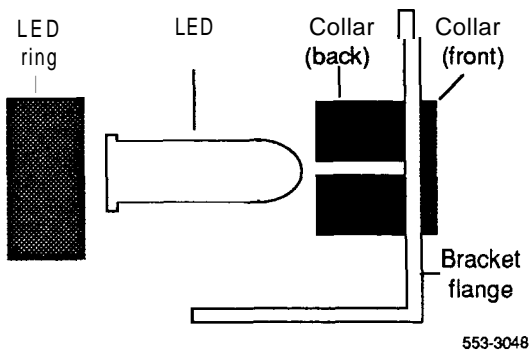

6 Install **the** Top Cap:

- Position **the** Top Cap and install the six screws that secure the Top Cap and perforated panel.
- Install the air exhaust grills at the front and back of **the** Top Cap.

7 Reconnect power to **the** Top Cap:

- Connect the ribbon cable connector to connector J2 on the backplane. Line up the alignment tab on the connector and snap on the pin headers to position the connector correctly.

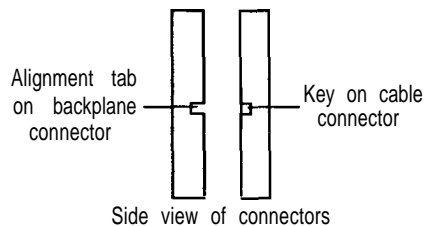

553-3048

- Connect the orange plug connector to the **UEM** power harness.

Note: For system option **21A**, reconnect the cable to connector **J3** on the System Monitor at this point.

- Replace the back cover on the UEM.
- Replace the backplane access plate.

8 Reconnect **the** System Monitor to the circuit breaker system:

Note: For system option **21A**, skip this step (**the** System Monitor is already connected).

- Push the System Monitor into position and tighten the screws.
- Replace the grill on the pedestal.

9 Tag defective equipment with a description of the problem and package it for return to a repair center.

Figure 7
Top cap assembly

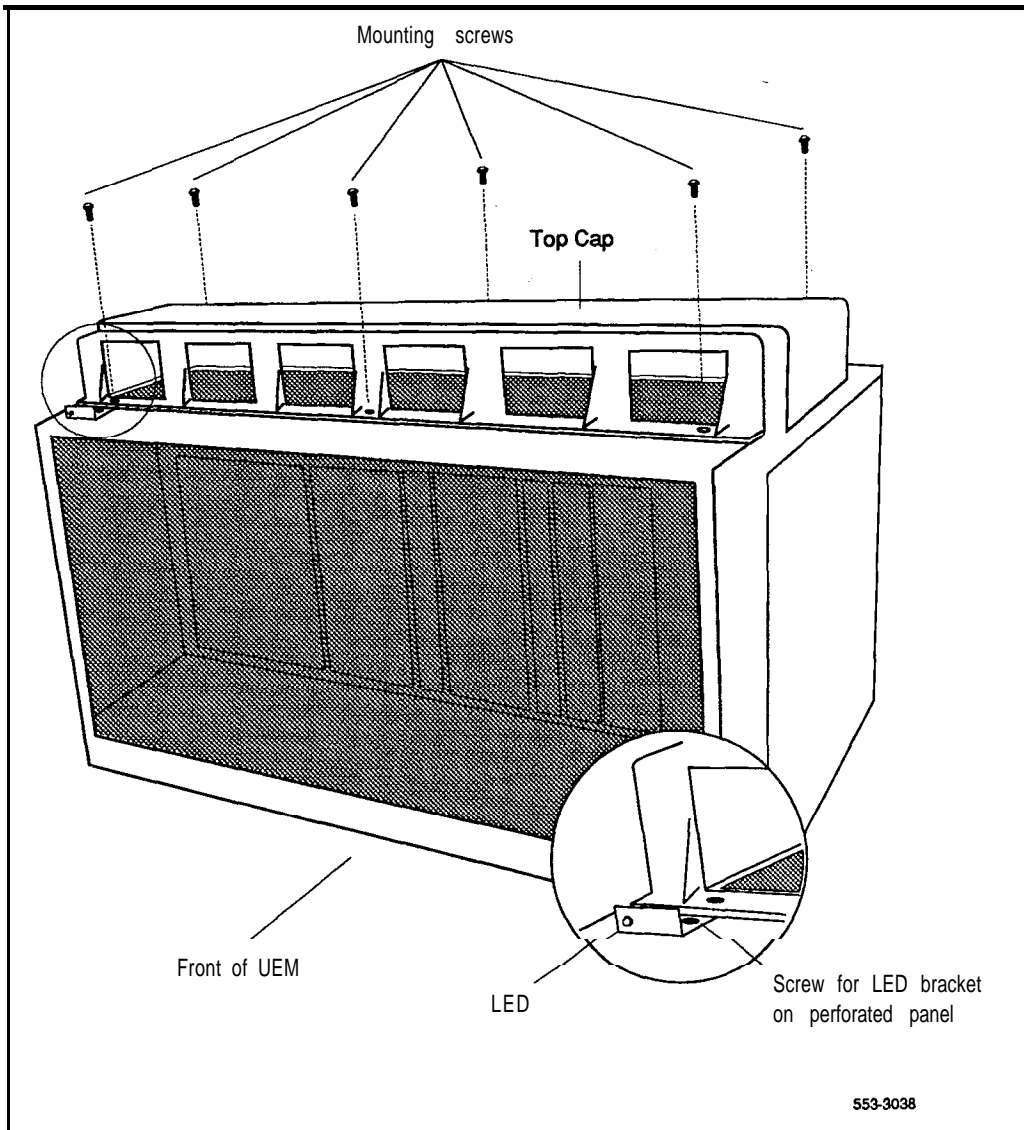



NT8D46AM Air Probe Harness-

Use this procedure to replace the Air Probe Harness in the Top Cap of each column (except system option 21A).

See the XII input/output guide (553-3001-400) for a description of **all** maintenance commands and system messages.

WARNING

UEM covers are **not** hinged; do **not** let go of the cover. Lift the cover away from the UEM and set it out of your work area.

Removing equipment

- 1 Disconnect the Air Probe Harness plug:
 - Remove **the** back cover on the **UEM** below the Top Cap.
 - Remove the backplane access plate on the I/O assembly.

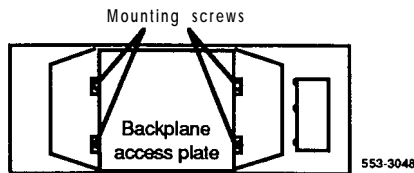

- At the top of the back of the UEM, disconnect the orange plug connector from the UEM power harness.
- 2 Remove the Top Cap:
 - Remove air exhaust grills at the front and back of the Top Cap. Pull forward on the two clips underneath the front edge of each grill to remove the grill.

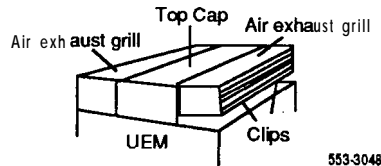

- Use a **5/16"** socket wrench to remove the six screws that secure the Top Cap and perforated panel (see Figure 8). Lift off the Top Cap.

3 Remove the Air Probe Harness:

- Remove the final screw that secures the perforated panel at the LED mounting bracket.
- Slide the perforated panel slightly to the left (looking at it from the back of the column). Lift the panel and turn it over.
- Pull the air probe out of the clip holder.
- Clip cable ties that secure the air probe wiring. Be careful not to damage other wiring (such as the Thermostat Harness).

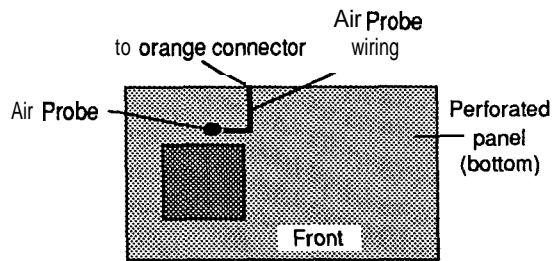

553-3048

- Remove the orange plug connector from the right-angle bracket at the top of the UEM. Simultaneously push the four small snaps (two on each side) on the connector to release it from the bracket.

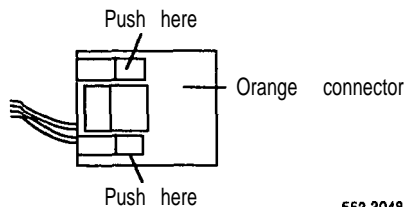

553-3048

-continued —

NT8D46AM Air Probe Harness (continued)

Installing equipment

- 4 Install the replacement Air Probe Harness:
 - Gently push the air probe into the clip holder.
 - Route the air probe wiring on the perforated panel. At the back edge of the panel, route the wires with wiring for the Thermostat Harness. Secure loose cabling to the perforated panel with cable ties.
 - Turn the perforated panel over. Slide it slightly to the right (at the back of the column) so it is in a secure position. Position wiring from the perforated panel so it rests in the cable well next to the orange plug connector at the back of the **UEM**.

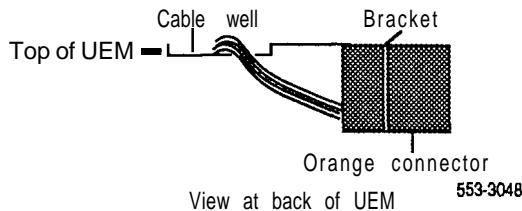

- Insert the orange plug connector into the right-angle bracket at the top of the **UEM**. Simultaneously push the four small snaps on the connector to insert it.
- 5 Install the Top Cap and perforated panel:
 - Position the perforated panel and install the screw that secures it at the LED bracket.
 - Position the Top Cap and install **the** six screws that secure the Top Cap and perforated panel.
 - Install the air exhaust grills at the front and back of the Top Cap.

- 6 Reconnect **the Air Probe** Harness plug:
 - Connect the orange plug connector to the **UEM** power harness.
 - Replace the back cover on the UEM.
 - Replace the backplane access **plate**.
- 7 Tag defective equipment with a description of the problem and package it for return to a repair center.

Figure 8
Top cap assembly

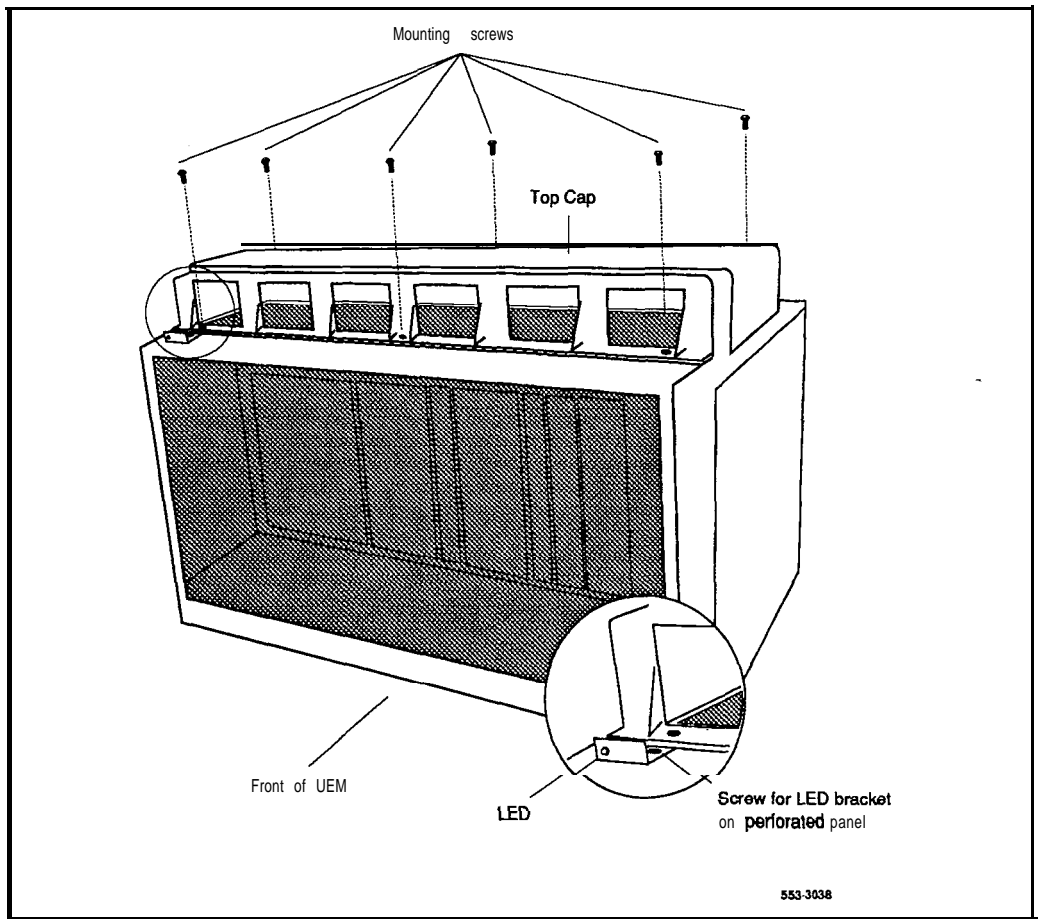

NT8D52AA and NT8D52DC Blower Unit

Use this procedure to replace a Blower Unit. Figure 9 shows the **NT8D52AA** Blower Unit and its location in the pedestal.

See **the *X11* input/output** guide (553-3001-400) for a description of all maintenance commands and system messages.

Removing equipment

- 1 Grasp the ridges on the outside upper edges of the front pedestal grill. Pull the grill away from the pedestal. Set the grill aside.

WARNING

Impellers in the Blower Unit do not stop instantly when the power is *turned off*. Wait *two full minutes* before you remove the unit.

- 2 Turn off power to the Blower Unit:
 - With AC power, set the circuit breaker on the front of the unit to OFF (down).
 - With DC power, set the toggle switch on the front of the unit to OFF (left).
- 3 Loosen the two screws on the front of the Blower Unit by turning them counter-clockwise.
- 4 Grasp the lip at the top edge of the Blower Unit. Slide the unit out of the glides and onto the bottom ledge of the pedestal. Lift the unit out of the pedestal.

Note: Store the Blower Unit in an upright position.

Installing equipment

- 5 Set the replacement Blower Unit on the bottom ledge of the pedestal.
- 6 Tilt the back of the Blower Unit up slightly so it will slide into the pedestal glides (you may need to lift the unit). Gently push the unit into position.
- 7 Tighten the screws on the front of the unit.

- 8 Turn on power to the Blower Unit:
 - With AC power, set the circuit breaker to ON (up).
 - With DC power, set the toggle **switch** to ON (right).
- 9 Fit the grill into the holes in the bottom ledge of the pedestal. Push the grill back into a locked position.
- 10 Tag defective equipment with a description of the problem and package it for return to a repair center.

Figure 9
NT8D52AA Blower Unit in the pedestal

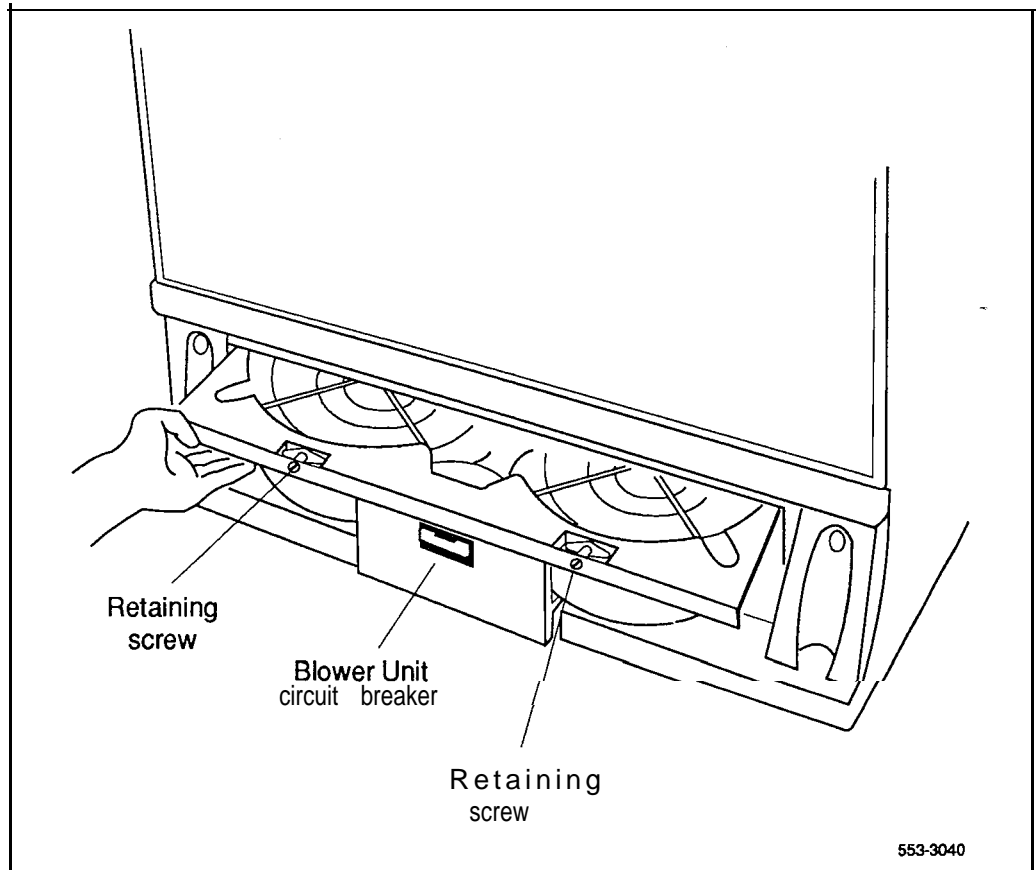

NT8D53AB Power Distribution Unit AC

Use this procedure to replace a Power Distribution Unit (PDU) AC. Figure 10 shows the location of the unit in the pedestal.

See the *X11 input/output guide (553-3001-400)* for a description of all maintenance commands and system messages.

WARNING

UEM covers are not hinged, do not let go of the cover. Lift the cover away from the UEM and set it out of your work area.

Removing equipment

- 1 Turn off power at the distribution box. If the column is not hardwired, unplug the power cable.
- 2 Remove the grill on the back of the pedestal.
- 3 Loosen the three mounting screws that secure the field wiring access plate. Lift the plate over the screws and set it aside.

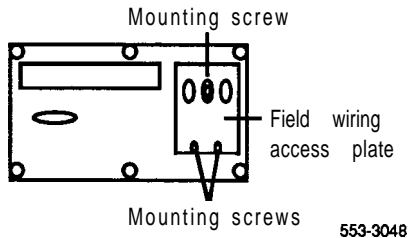

- 4 Tag and disconnect wiring to the right side of the field wiring terminal. Push all the wires down into the empty area under the pedestal.

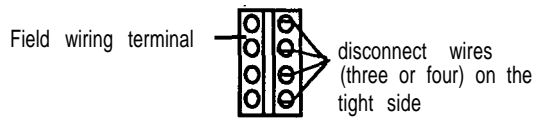

553-3048

CAUTION

Label wires carefully. They must be reconnected correctly or the system may be damaged.

- 5 Tag and disconnect cables to the **NT8D22AB** System Monitor. Loosen the two retaining screws on the System Monitor. Remove the card.
- 6 Disconnect cables to the UEM above the pedestal (**UEM 0**):
 - Remove the back cover on UEM 0.
 - Remove the backplane access plate on the I/O assembly.

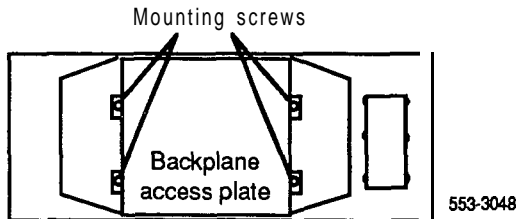

553-3048

- Disconnect the power plug (**J1**) and System Monitor ribbon cable to UEM 0.

Note: To disconnect the power plug, you must press a latch trip on the front and back of the plug. You may need to use a screwdriver blade against the latch trip on the front of the plug.

- 7 Remove the six screws that position the PDU. Carefully pull the unit straight forward out of the pedestal.

-continued -

NT8D53AB Power Distribution Unit AC (continued)

Installing equipment

- 8 Set the main circuit breaker on the replacement PDU to **OFF** (down).
- 9 Position the replacement PDU and gently **push.it** into the pedestal.

Note: Be sure you push the unit straight back, so the connector on the back will seat properly with the Fan or Blower Unit connector. It may be easier to position the PDU if you temporarily pull **the** Fan or Blower Unit out several inches.

- 10 Reconnect cables to UEM 0:
 - Attach power plug **J1** and the System Monitor cable.
 - Replace the backplane access plate on the I/O assembly.
 - Replace the back cover on the UEM.
- 11 Insert the System Monitor. Tighten the screws on the card. Reconnect cables to the System Monitor faceplate.
- 12 Connect wiring to the right side of the field wiring terminal.
- 13 Position the field wiring access plate over the three mounting screws. Tighten the screws.
- 14 Turn on power at the distribution box or plug in the power cable.
- 15 Set the main circuit breaker to ON (up).
- 16 Replace the pedestal grill.
- 17 Tag defective equipment with a description of the problem and package it for return to a repair center.



Figure 10
Power Distribution Unit AC In the pedestal

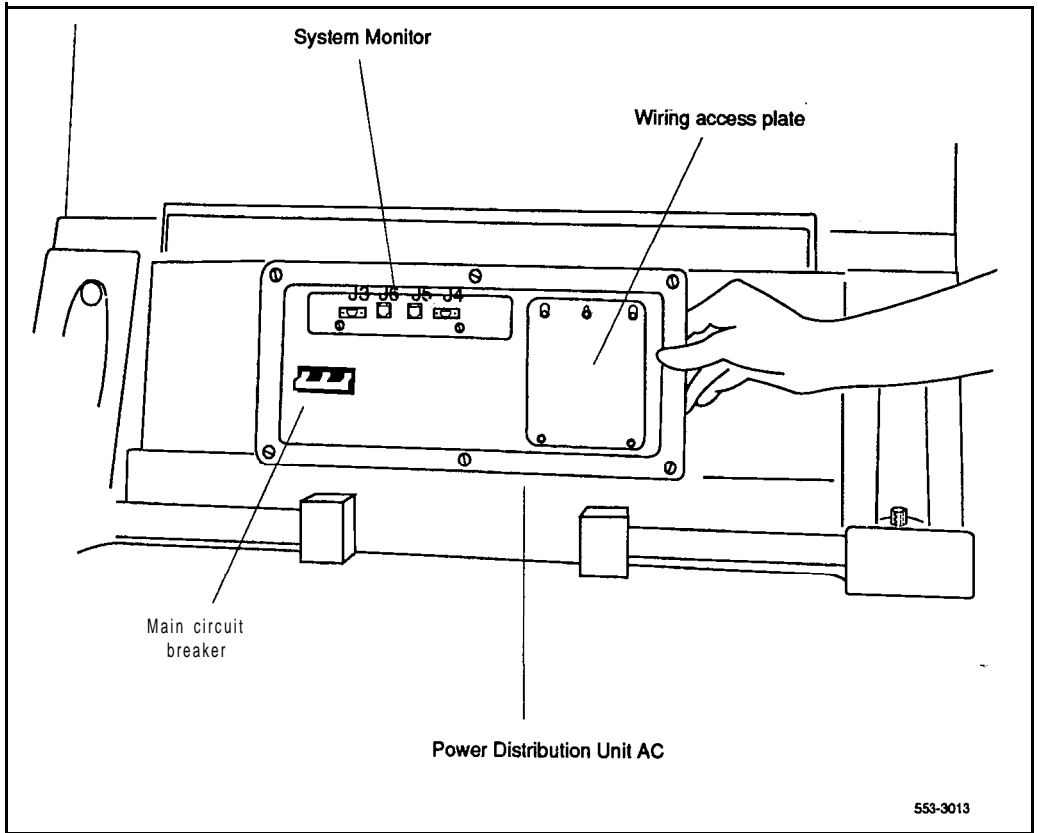

NT8D53AD Power Distribution Unit (system. option 21 A)

The Power Distribution Unit, used in system option **21A**, is located in the pedestal. Use this procedure to replace a Power Distribution Unit.

See the *XII input/output guide (553-3001-400)* for a description of all maintenance commands and system messages.

WARNING

UEM covers are *not* hinged; do *not* let go of the cover. Lift the cover away from the UEM and set it out of your work area.

Removing equipment

- 1 Set the circuit breaker on the Power Distribution Unit to OFF (down).
- 2 Unplug **the** power cable from the external outlet.
- 3 Disconnect the power cable from the pedestal to the UEM:
 - Remove **the** back cover on the UEM.
 - Remove the backplane access plate on the I/O assembly.

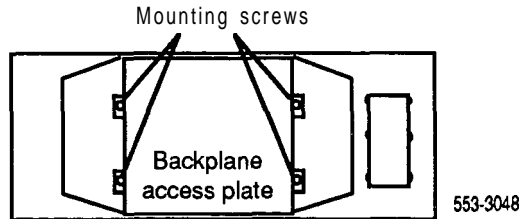

- Disconnect the power plug at connector J 1.

Note: To disconnect the power plug, you must press a latch trip on the front and back of the plug. You may need to use a screwdriver blade against the latch hip on the **front** of the plug.

- 4 Remove the grill on the back of the pedestal.
- 5 Remove **the** six screws that position the Power Distribution Unit and lift **the** unit out of the pedestal (see Figure 11).

- 6 Tag and disconnect wiring to the back of the panel:
 - Disconnect cables from System Monitor to connectors C 1 and C2.
 - Remove **the** cover over the terminal block (TB 1). Disconnect wiring from the power cord to connectors **L1** and L2 on the terminal block.
 - Disconnect the ground wiring by removing **the** ground bolt from inside the pedestal.

CAUTION

Label wires carefully. They must be reconnected correctly or the system may be damaged.

Installing equipment

- 7 Set the circuit breaker on the replacement panel to OFF (down).
- 8 Connect wiring to the replacement panel:
 - Install the ground bolt and wiring inside **the** pedestal.
 - Connect wiring from the power cord to connectors **L1** and **L2** on the terminal block. Replace the cover over the terminal block.
 - Connect cables from System Monitor to connectors C1 and C2.
- 9 Reconnect the power cable from the pedestal to the **UEM**:
 - Attach the power plug at connector **J1**.
 - Replace the backplane access plate on the I/O assembly.
 - Replace the back cover on the **UEM**.
- 10 Position **the** replacement panel and replace the screws.
- 11 Plug the power cable into the external outlet.
- 12 Set the circuit breaker on the panel to ON (up).
- 13 Replace the pedestal grill.
- 14 Tag defective equipment with a description of the problem and package it for return to a repair center.

Figure 11
Power Distribution Unit (system option 21A)

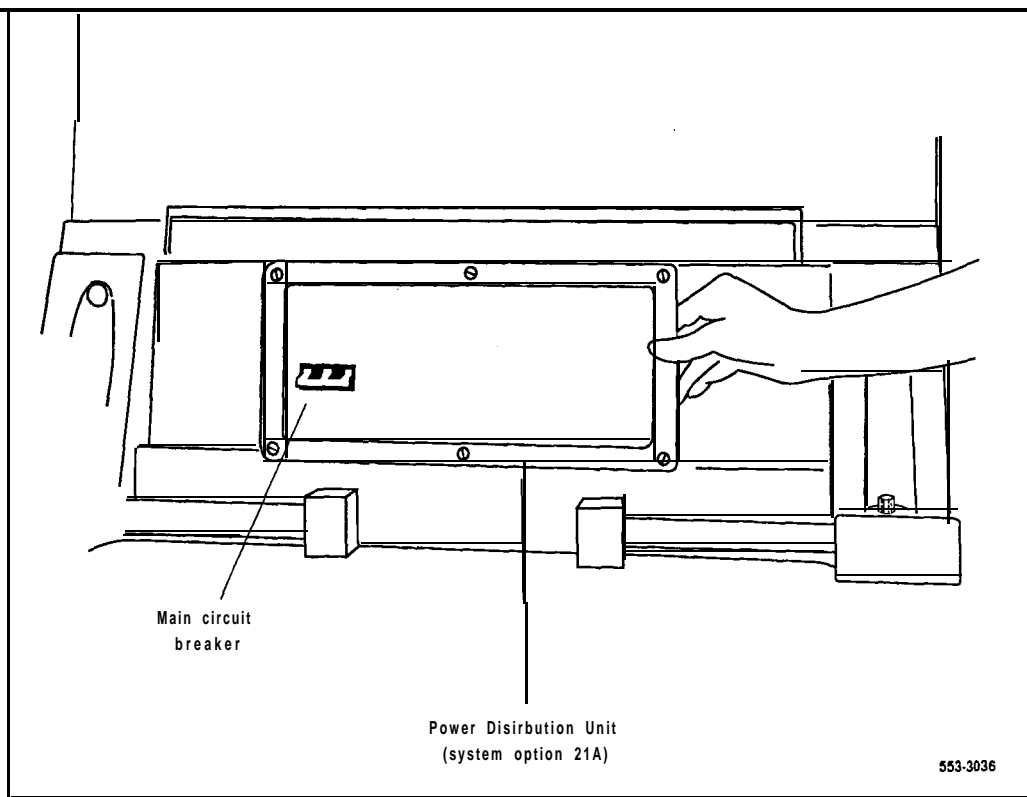



NT8D56AA, NT8D56AC, NT8D57AA Module Power Distribution Unit

Use this procedure to replace the following Module Power Distribution Units (MPDUs):

- **NT8D56AA** single breaker MPDU (used with **NT8D29AA** Common Equipment Power Supply AC)
- **NT8D56AC** single breaker MPDU (used with **NT7D14AA** Common/Peripheral Equipment Power Supply AC in some configurations)
- **NT8D57AA** dual breaker MPDU (used with **NT8D06AA** Peripheral Equipment Power Supply AC and **NT8D21AA** Ringing Generator AC)

See the *XII input/output guide* (553-3001-400) for a description of all maintenance commands and system messages.

WARNING

UEM covers are *not* hinged: do *not* let go of the cover. Lift the cover away from the UEM and set it out of your work area.

Removing equipment

- 1 Remove the back grill on the column pedestal. Set the main circuit breaker to **OFF** (down).

CAUTION

Shutting off the main circuit breaker disables the entire column.

- 2 Remove the power plug access plate on the I/O assembly in the back of the UEM by removing the screws on each side. Set the plate aside.

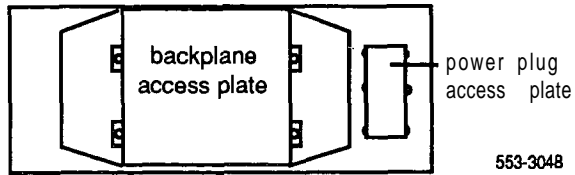

- 3 Tag and disconnect the power plugs to the MPDU.
- 4 Remove **the** metal plate covering the MPDU in the front of the UEM by removing the mounting screw in each corner.
- 5 Unhook the locking devices on the power supply next to **the** MPDU. Pull the power supply out of the card cage.
- 6 Remove the mounting screws for the MPDU; the screw-heads are in the wall of the power supply slot. (**BE CAREFUL** — do not let the screws fall into the UEM below.) Lift **the** unit out of the UEM.

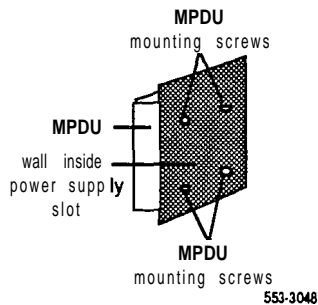

Installing equipment

- 7 Set the circuit breaker(s) on the replacement MPDU to **OFF** (down).
- 8 Position the replacement MPDU in the UEM. Install the mounting screws through the wall of the power supply slot.

-continued —

**NT8D56AA, NT8D56AC, NT8D57AA Module Power Distribution Unit
(continued)**

- 9 Reinsert the power supply and hook the locking devices.
- 10 Position **the** metal plate in front of **the** MPDU and install the mounting screw in each corner.
- 11 Connect the power plugs to the back of the MPDU.
- 12 Position the power plug access plate. Tighten the screws.
- 13 Set the circuit breaker(s) on the replacement MPDU to ON (up).
- 14 Reset the main circuit breaker in **the** column pedestal to ON (up) and replace the pedestal grill.
- 15 Tag defective equipment with a description of the problem and package it for return to a repair center.





NT8D68AA Floppy Disk Unit

Use this procedure to replace the Floppy Disk Unit (**FDU**).

See the *XII input/output* guide (553-3001-400) for a description of all maintenance commands and system messages.



WARNING

UEM covers are not hinged; do not let go of the cover. Lift the cover away from the UEM and set it out of your work area.

Removing equipment

- 1 Software disable the Floppy Disk Unit by entering

DIST
(This command is entered directly through the Overlay Loader program. No other program should be active.)
- 2 Set the **ENB/DIS** switch to DIS on the associated QPC742 **Floppy** Disk Interface (**FDI**) Card.
- 3 Remove the disks from the FDU.
- 4 Tag and disconnect the cable(s) to the faceplate of the FDU.
- 5 Unhook the locking devices on the FDU and pull the unit out of the card cage.

installing equipment

- 6 Insert the replacement FDU into the vacated slot and hook the locking devices.
- 7 Connect the cable(s) to the replacement FDU.
- 8 Install the disks in the replacement FDU.
- 9 Set the **ENB/DIS** switch to ENB on the associated FDI.
- 10 Software enable the FDU by entering
ENLT
(This command is also entered directly through the Overlay Loader.)



- 11 Test the **FDU** by entering
LD 37
MSI x
(**"x"** represents the FDI number 0 or 1)
 - If there is a problem, an IOD **system** message will be generated.
 - End the session in LD 37 by entering

- 12 Tag defective equipment with a description of the problem **and** package it for return to a repair center.

NT8D69AA Multi Disk Unit

Use this procedure to replace the Multi Disk Unit (MDU).

See the *XII input/output guide* (553-3001-400) for a description of all maintenance commands and system messages.



WARNING

UEM covers are *not* hinged; do *not* let go of the cover. Lift the cover away from the UEM and set it out of your work area.

Removing equipment

- 1 Software disable the Multi Disk Unit by entering

DIST

(This command is entered **directly** through the Overlay Loader program. No other program should be active.)

- 2 Remove the floppy disks from their disk drives.
- 3 Tag and disconnect the cable(s) to the faceplate of the MDU.
- 4 Unhook the locking devices on the MDU and gently pull the unit forward two or three inches. Wait at least ten seconds, then pull the unit out of the card cage.

CAUTION

You must wait *at least* 10 seconds before you remove the MDU from the card cage.

Installing equipment

- 5 Insert the replacement MDU into the vacated slot and hook the locking devices.
- 6 Install the floppy disks in the replacement MDU.
- 7 Connect the cable(s) to the faceplate of the MDU.



- 8 Software enable the FDU by entering
ENLT
(This command is also entered directly through the Overlay Loader.)
- 9 Test the MDU by entering
LD37
MSI x
("x" represents the **MSI** number 0 or 1)
- If there is a problem, an IOD system message will be generated.
 - End the session in LD 37 by entering

- Note:** When the MDU is replaced, transfer data from system memory or backup disks to the new hard disk using LD 43. See the XII *input/output guide*.
- 10 Tag defective equipment with a description of the problem and package it for return to a repair center.

NT8D1103 Common/Peripheral Equipment Card Cage Assembly

To replace a defective **NT8D1102** Common/Peripheral Equipment Backplane, you must replace the **NT8D1103** Common/Peripheral Equipment Card Cage Assembly. Use this procedure to replace the unit.

See the XII *input/output* guide (553-3001-400) for a description of all maintenance commands and system messages.

WARNING

UEM covers are not hinged; do not let go of the cover. Lift the cover away from the UEM and set it out of your work area.

Removing equipment

- 1 Unseat disks in the Floppy Disk Unit (FDU) from the disk drives.
- 2 Turn off power to the UEM power supply:
 - With AC power, set the circuit breaker on the NT8D56AC Module Power Distribution Unit (MPDU) to **OFF** (down).
 - With DC power, set the switch on the NT7D14AA Common/Peripheral Equipment Power Supply to **OFF** (down).
- 3 Remove all cards from the UBM:
 - Tag and disconnect cables to all faceplate connectors.
 - Tag cards so they can be returned to the same slot. Remove cards.
- 4 Disconnect cables, plugs, and wires from the back of the UEM to the backplane:

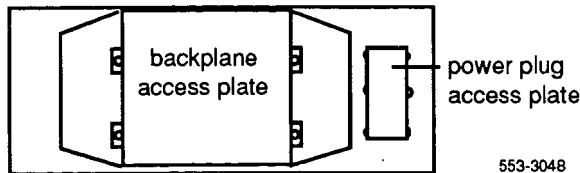

- Remove **the** backplane access plate by turning the screws on each side. Set the plate aside.
 - Tag and disconnect all cables from the backplane to the interior of the **I/O** assembly.
 - Remove the power plug access plate by turning the screws on each side. Set the plate aside.
 - Tag and disconnect all plugs, wires, and cables to the backplane.
- 5 Remove the two mounting screws that secure the back of the card cage to the UEM assembly.
 - 6 Remove **the** front cover plates on **both** sides of the card cage.
 - 7 Remove the three mounting screws that secure the front of the card cage to the bottom of the UEM assembly. Pull the card cage out of the UEM.

Installing equipment

- 8 Slide the replacement card cage into position in the **UEM**. Install **the** mounting screws at the front of the card cage.
- 9 Replace the front cover plates on both sides of the card cage.
- 10 Install the mounting screws at the back of the card cage.
- 11 Reconnect cables, plugs, and wires from the back of the UEM to the backplane:
 - Connect all cables from the interior of the I/O assembly to the backplane.
 - Position the backplane access plate. Tighten the screws.
 - Connect all plugs, wires, and cables to the backplane.
 - Position **the** power plug access plate. Tighten the screws.
- 12 Return cards to their slots. Reconnect all cables to faceplate connectors.

-continued —

**NT8D1103 Common/Peripheral Equipment Card Cage Assembly
(continued)**

- 13 Turn on power to the UEM power supply:
 - With AC power, set the MPDU circuit breaker to ON (tip).
 - **With** DC power, set the power supply switch to ON (up).
- 14 Reinsert disks into the disk drive unit.
- 15 Tag defective equipment with a description of the problem and package it for return to a repair center.





NT8D1303 Peripheral Equipment Card Cage Assembly

To replace a defective NT8D1302 Peripheral Equipment Backplane, you must replace the NT8D1303 Peripheral Equipment Card Cage Assembly. Use this procedure to replace the unit.

See **the X11 input/output guide (553-3001-400)** for a description of all maintenance commands and system messages.



WARNING

UEM covers are *not* hinged; do *not* let go of the cover. Lift the cover away from the UEM and set it out of your work area.

Removing equipment

- 1 Disable the Peripheral Equipment shelf by entering
LD 32
DISS 1 s
("1 s" represents the loop and shelf number)

If a second shelf is assigned to a loop, disable that shelf also by entering
DISS 1 s
- 2 Turn off power to the UEM power supply:
 - With AC power, set the circuit breaker(s) on the NT8D57AA Module Power Distribution Unit (MPDU) to OFF (down).
 - With DC power, set the switch on the NT8D06AA Peripheral Equipment Power Supply and NT8D21AA Ringing Generator to OFF (down).
- 3 Remove all cards from the UEM:
 - Tag and disconnect cables to all faceplate connectors.
 - Tag cards so they can be returned to the same slot. Remove cards.



- 4 Disconnect cables, plugs, and wires from the back of the UEM to the backplane:

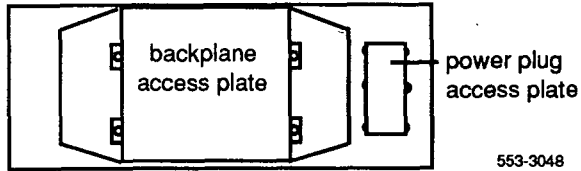

- Remove the backplane access plate by turning the screws on each side. Set the plate aside.
 - Tag and disconnect all cables from the backplane to the interior of the I/O assembly.
 - Remove the power plug access plate by turning the screws on each side. Set **the** plate aside.
 - Tag and disconnect all plugs, wires, and cables to the backplane.
- 5 Remove **the** two mounting screws that secure **the** back of the card cage to the UEM assembly.
- 6 Remove the front cover plates on **both** sides of the card cage.
- 7 Remove the three mounting screws that secure the front of the card cage to the bottom of the UEM assembly. Pull the card cage out of the **UEM**.

Installing equipment

- 8 Slide **the** replacement card cage into position in the UEM. Install **the** mounting screws at the front of the card cage.
- 9 Replace the front cover plates on both sides of the card cage.
- 10 Install the mounting screws at the back of the card cage.

-continued —

NT8D1303 Peripheral Equipment Card Cage Assembly (continued)

- 11 Reconnect cables, plugs, and wires from the UEM to the backplane:
 - Connect all cables from the interior of the I/O assembly to the backplane.
 - Position the backplane access plate. Tighten the screws.
 - Connect all plugs, wires, and cables to the backplane.
 - Position the power plug access plate. Tighten the screws.
- 12 Return cards to their slots. Reconnect all cables to connectors.
- 13 Turn on power to the UEM power supply:
 - With AC power, set the MPDU circuit breaker to ON (up).
 - With DC power, set the power supply switch to ON (up).
- 14 Enable the shelf by entering
ENLS **1 s**

If a second shelf is assigned to a loop, enable that shelf also by entering
ENLS 1 s

End the session in LD 32 by entering

- 15 Test **the** shelf by testing each loop with
LD 30
LOOP 1 s

If there is a problem, an NWS system message will be generated.

End the session in LD 30 by entering

- 16 Tag defective equipment with a description of the problem and package it for return to a repair center.





NT8D3403 CPU Card Cage Assembly

To replace a defective NT8D3401 CPU Backplane, you must replace the NT8D3403 CPU Card Cage Assembly. Use this procedure to replace the unit,

See the *XII input/output* guide (553-3001-400) for a description of all maintenance commands and system messages.

WARNING

UEM covers are *not* hinged, do *not* let go of the cover. Lift the cover away from the UEM and set it out of your work area.

Removing equipment

- 1 The CPU on the backplane you are replacing must be inactive:
 - If you need to switch CPUs, enter
LD 35
SCPU

End the session in LD 35 by entering

 - Set the **NORM/MAINT** switch to **MAINT** on the *active* CPU Interface (IF) Card. (This keeps the system from switching to the inactive CPU.)
 - Set *the* **ENB/DIS** switch to **DIS** on *the inactive* Interface Card.
- 2 If the Multi Disk Unit (**MDU**) or Floppy Disk Unit (**FDU**) is located in the UEM, move the unit to the other CPU UEM:
 - Remove floppy disks from the disk drives.
 - Tag and disconnect cables to the unit.

- Unhook the locking devices on the unit; pull it out of the card cage.

CAUTION

If you are moving an MDU, pull it forward two or three inches, then wait at *least 10* seconds before you remove the MDU from the card cage.

- Insert the unit in an acceptable slot in the other CPU UEM. See **Circuit pack installation and testing** (553-3001-211) for slot assignments.
 - Return floppy disks to the disk drives.
 - Reconnect cables to the unit.
- 3 Turn off power to the UEM power supply:
- With AC power, set the circuit breaker on the **NT8D56AA** Module Power Distribution Unit (**MPDU**) to OFF (down).
 - With DC power, set the switch on the **NT8D29AA** Common Equipment Power Supply to OFF (down).
- 4 Remove all cards from the UEM:
- Tag and disconnect cables to all faceplate connectors.
 - Tag cards so they can be returned to **the** same slot. Remove cards.
- 5 Disconnect cables, plugs, and wires from the back of the UEM to the backplane:

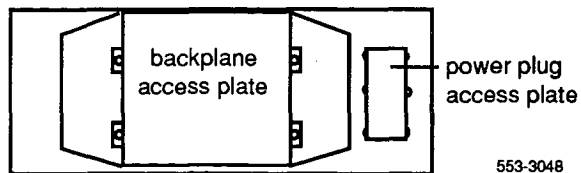

- Remove the backplane access plate by turning the screws on each side. Set the plate aside.

continued —

NT8D3403 CPU Card Cage Assembly (continued)

- Tag and disconnect all cables from the backplane to the interior of the I/O assembly.
 - Remove the power plug access plate by turning the screws on each side. Set the plate aside.
 - Tag and disconnect all plugs, wires, and cables to the backplane.
- 6 Remove the two mounting screws that secure the back of the card cage to the UEM assembly.
 - 7 Remove the front cover plates on both sides of the card cage.
 - 8 Remove the three mounting screws that secure the front of the card cage to the bottom of the UEM assembly. Pull the card cage out of the UEM.

Installing equipment

- 9 Slide the replacement card cage into position in the UEM. Install the mounting screws at the front of the card cage.
- 10 Replace the front cover plates on both sides of the card cage.
- 11 Install the mounting screws at the back of the card cage.
- 12 Reconnect cables, plugs, and wires from the back of the UEM to the backplane:
 - Connect all cables from the interior of the I/O assembly to the backplane.
 - Position the backplane access plate. Tighten the screws.
 - Connect all plugs, wires, and cables to the backplane.
 - Position the power plug access plate. Tighten the screws.
- 13 Return cards to their slots. Reconnect all cables to faceplate connectors.
- 14 Turn on power to the UEM power supply:
 - With AC power, set the MPDU circuit breaker to ON (up).
 - With DC power, set the power supply switch to ON (up).

15 If the MDU **or** FDU is located in the UEM, reinsert disks into **the** disk drive unit.

16 Enable the CPU:

- Set the **ENB/DIS** switch to ENB on the inactive Interface Card.
- Set the **NORM/MAINT** switch to NORM on **the** active Interface Card.

17 Tag defective equipment with a description of the problem and package it for return to a repair center.

NT8D3503 Network Card Cage Assembly

To replace a defective NT8D3501 Network Backplane, you must replace the NT8D3503 Network Card Cage Assembly. Use this procedure to replace the unit.

See the *X11 input/output guide* (553-3001-400) for a description of all maintenance commands and system messages.

WARNING

UEM covers are **not** hinged; do **not** let go of the cover. Lift the cover away from the UEM and set it out of your work area.

Removing equipment

- 1 Software disable the following:
 - Disable the Three Port Extender (3PE) Card by disabling the associated Segmented Bus Extender (SBE) Card (**the CPU associated with the SBE must be inactive**). Enter
LD 35
DIS EXT xxx
(Table 4 lists extender codes specified by "xxx")

End the session in LD 35 by entering

 - Disable all network loops on the shelf by disabling the Peripheral Signaling Card. Enter
LD 32
DSPS x
(Table 5 lists the loops represented by "x")

End the session in LD 32 by entering

 - Disable all other cards that might be in the UEM, such as Serial Data Interface (SDI) Cards or Primary Rate Interface (PRI) Cards.

Table 4
 Extender codes

Extender number	From	To
0G0	CPU 0	Network Group 0
0G1	CPU 0	Network Group 1
0G2	CPU 0	Network Group 2
0G3	CPU 0	Network Group 3
0G4	CPU 0	Network Group 4
1G0	CPU 1	Network Group 0
1G1	CPU 1	Network Group 1
1G2	CPU 1	Network Group 2
1G3	CPU 1	Network Group 3
1G4	CPU 1	Network Group 4

Table 5
 Network loop codes

Group/ shelf	Peripheral signaling card	Loops disabled/enabled		
0/0	0	0	—	15
0/1	1	16	—	31
1/0	2	32	—	47
1/1	3	48	—	63
2/0	4	64	—	79
2/1	5	80	—	95
3/0	6	96	—	111
3/1	7	112	—	127
4/0	8	128	—	143
4/1	9	144	—	159

- If the Multi Disk Unit (**MDU**) or Floppy Disk Unit (**FDU**) is located in the UEM, unseat disks from the disk drives.

-continued —

NT8D3503 Network Card Cage Assembly (continued)

- 3 **Turn** off power to the UEM power supply:
 - With AC power, set the circuit breaker on the **NT8D56AA** Module Power Distribution Unit (**MPDU**) to OFF (down).
 - With DC power, set the switch on the **NT8D29AA** Common Equipment Power Supply to OFF (down).
- 4 Remove all cards from the UEM:
 - Tag and disconnect cables to all faceplate connectors.
 - Tag cards so they can be returned to the same slot. Remove cards.
- 5 Disconnect cables, plugs, and wires from the back of the UEM to the backplane:

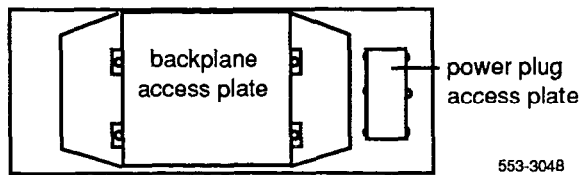

- Remove the backplane access plate by **turning** the screws on each side. Set the plate aside.
 - Tag and disconnect all cables from the backplane to the interior of the I/O assembly.
 - Remove the power plug access plate by turning the screws on each side. Set the plate aside.
 - Tag and disconnect all plugs, wires, and cables to the backplane.
- 6 Remove the two mounting screws that secure the back of the card cage to the bottom of the UEM assembly.
 - 7 Remove the front cover plates on both sides of the card cage.
 - 8** Remove the three mounting screws that secure the front of the card cage to the bottom of the UEM assembly. Pull **the** card cage out of the **UEM**.

Installing equipment

- 9 Slide the replacement card cage into position in the UBM. Install the mounting screws at the front of the card cage.
- 10 Replace the front cover plates on both sides of the card cage.
- 11 Install the mounting screws at the back of the card cage.
- 12 Reconnect cables, plugs, and wires to the backplane:
 - Connect all cables from the interior of the I/O assembly to the backplane.
 - Position the backplane access plate. Tighten the screws.
 - Connect all plugs, wires, and cables to the backplane.
 - Position the power plug access plate. Tighten the screws.
- 13 Return cards to their slots. Reconnect all cables to connectors.
- 14 Turn on power to the UEM power supply:
 - With AC power, set the MPDU circuit breaker to ON (up).
 - With DC power, set the power supply switch to ON (right).
- 15 If the MDU or FDU is in the UBM, reinsert disks into the drive.
- 16 Software enable the following:
 - Enable the 3PE by enabling the associated SBE. Enter
LD 35
ENL EXT xxx

End the session in LD 35 by entering

 - Enable the Peripheral Signaling Card by entering
LD 32
ENPS x

End the session in LD 32 by entering

 - Enable any other disabled cards.

-continued -

NT8D3503 Network Card Cage Assembly (continued)

17 Test network loops by entering

LD 30

LOOP **all**

- If there is a problem, an NWS system **message** will be generated.
- End the session in LD 30 by entering

18 Tag defective equipment with a description of the problem and package it for return to a repair center.



NT8D3703 Intelligent Peripheral Equipment Card Cage Assembly

To replace a defective **NT8D3701** Intelligent Peripheral Equipment Backplane, you must replace the **NT8D3703** Intelligent Peripheral Equipment Card Cage Assembly. Use this procedure to **replace the** unit.

See the *X11 input/output guide (553-3001-400)* for a description of all maintenance commands and system messages.

WARNING

UEM covers are *not* hinged; do *not* let go of the cover. Lift the cover away from the UEM and set it out of your work area.

Removing equipment

- 1 Disable all loops on the Peripheral Equipment (**PE**) shelf by entering
LD 32
DSXP x
("x" represents the Controller Card number)
- 2 Turn off power to the UEM power supply:
 - With AC power, set the circuit breaker on the **NT8D57AA** Module Power Distribution Unit (**MPDU**) to **OFF** (down).
 - With DC power, set the switch on the **NT8D06AA** Peripheral Equipment Power Supply and **NT8D21AA** Ringing Generator to **OFF** (down).
- 3 Remove all cards from the UEM:
 - Tag and disconnect cables to all faceplate connectors.
 - Tag cards so they can be returned to **the** same slot. Remove cards.

- 4 Disconnect cables, plugs, and wires from the back of the UEM to **the** backplane:

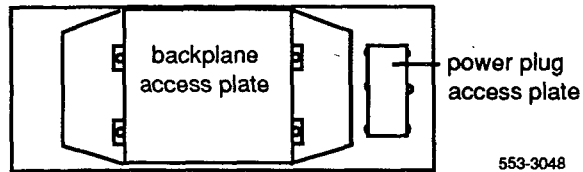

- Remove the backplane access plate by turning the screws on each side. Set the plate aside.
 - Tag and disconnect all cables from the backplane to the interior of the I/O assembly.
 - Remove the power plug access plate by turning the screws on each side. Set the plate aside.
 - Tag and disconnect all plugs, wires, and cables to the backplane.
- 5 Remove the two mounting screws that secure the back of the card cage to the **UEM** assembly.
- 6 Remove the front cover plates on both sides of the card cage.
- 7 Remove the three mounting screws that secure the front of the card cage to the bottom of the UEM assembly. Pull the card cage out of the **UEM**.

installing equipment

- 8 Slide **the** replacement card cage into position in the UEM. Install the mounting screws at the front of **the** card cage.
- 9 Replace the front cover plates on both sides of the card cage.
- 10 Install the mounting screws at the back of the card cage.

-continued —

**NT8D3703 intelligent Peripheral Equipment Card Cage Assembly
(continued)**

- 11 Reconnect cables, plugs, and wires from the back of the UEM to the backplane:
 - Connect all cables from the interior of the I/O assembly to the backplane.
 - Position the backplane access plate. Tighten the screws.
 - Connect all plugs, wires, and cables to the backplane.
 - Position the power plug access plate. Tighten the screws.
- 12 Return cards to their slots. Reconnect all cables to faceplate connectors.
- 13 Turn on power to the UEM power supply:
 - With AC power, set the MPDU circuit breaker to ON (up).
 - With DC power, set the power supply switch to ON (up).
- 14 Enable the shelf by entering
ENXP x
End the session in LD 32 by entering

- 15 Test the shelf by testing each loop with
LD 30
LOOP 1 s
("1 s" represents the loop and shelf number)
 - If there is a problem, an NWS system message will be generated.
 - End the session in LD 30 by entering

- 16 Tag defective equipment with a description of the problem and package it for return to a repair center.





QMM42 Data Cartridge

Use this procedure to replace the Data Cartridge on the **QPC584** Mass Storage Interface (MSI) Card or **QPC742** Floppy Disk Interface (**FDI**) Card.

See the XII input/output guide (553-3001-400) for a description of all maintenance commands and system messages.

WARNING

UEM covers are **not** hinged: do not let go of the cover. Lift the cover away from the UEM and set it out of your work area.

Removing equipment

- 1 Disable the **MSI** or **FDI**:
 - The associated CPU must be inactive. If you need to switch **CPUs**, enter
LD 35
SCPU
End the session in LD 35 by entering

 - Software disable the **MSI** or **FDI** by entering
LD 37
DIS MSI x
("x" represents the **MSI** or **FDI** number)
 - Set the **ENB/DIS** switch to **DIS** on the **MSI** or **FDI**.

CAUTION

To avoid interrupting service, set **ENB/DIS** switches to **DIS** before disconnecting or connecting cables.

- 2 Disconnect the cable to the card you are removing.
- 3 Unhook the locking devices on the card; pull it out of the card cage.
- 4 Remove the screw that secures the Data Cartridge. Gently unplug the cartridge from the connectors on the component side of the **MSI** or **FDI**.

Installing equipment

- 5 Plug the replacement Data Cartridge into the connectors on the component side of the **MSI** or **FDI**. Install the screw that secures the cartridge.

CAUTION

To avoid system failure, the ID number on the data cartridge must match **the** ID number of the SL-1.

- 6 Reinsert the card and hook the locking devices.
- 7 Reconnect the cable to the card.
- 8 Set the **ENB/DIS** switch to ENB.
- 9 Test the **MSI** or **FDI** by entering
LD 37
MSI x
("x" represents the Multi Disk Unit or Floppy Disk Unit number)
 - If there is a problem, an IOD system message will be generated and the red LED will light on the faceplate of the card.
 - End the session in LD 37 by entering

- 10 Tag defective equipment with a description of **the** problem and package it for return to a repair center.

QPC43 Peripheral Signaling Card

Use **this** procedure to replace a Peripheral Signaling Card.

See the XII **input/output guide** (553-3001-400) for a description of all maintenance commands and system messages.



WARNING

UEM covers are not hinged; do **not** let go of the cover. Lift the cover away from the UEM and set it out of your work area.

CAUTION

Disabling or removing a Peripheral Signaling Card from a Network shelf disables all loops on that shelf.

Removing equipment

- 1 Check the status of the Peripheral Signaling Card by entering **LD 32 STAT PER x**
(Table 6 lists Peripheral Signaling Card numbers specified by “x”)
 - If the response is **DSBL**, go to Step 2.
 - If the response is **ENBL**, enter **DSPS x** to disable the card, then go to Step 2.
- 2 Set the **ENB/DIS** switch to DIS.
- 3 Unhook the locking devices on the **card**; pull it out of the card cage.

Installing equipment

- 4 Set the **ENB/DIS** switch to DIS on the replacement card.
- 5 Set the jumper plug on the replacement card the same as on the card you removed. To check switch settings, **see Circuit pack installation and resting** (553-3001-211).
- 6 Insert the replacement card into the vacated slot and hook the locking devices.



- 7 Set the **ENB/DIS** switch to ENB on the replacement card.
- 8 Software enable the card and loops serviced by the card by entering ENPS x
 - When the process is complete, **yōu** will receive a system response.
 - If there is a problem, an NPR system message will be generated and the red LED will light on the faceplate of the card.
 - End the session in LD 32 by entering

- 9 Test each loop serviced by the Peripheral Signaling Card by entering LD 30
LOOP loop
("loop" represents a loop number)
End the session in LD 30 by entering

- 10 Tag defective equipment with a description of the problem and package it for return to a repair center.

Table 6
Peripheral Signaling Card numbers

Group/ shelf	Peripheral signaling card	Loops disabled/enabled		
0/0	0	0	—	15
0/1	1	16	—	31
1/0	2	32	—	47
1/1	3	48	—	63
2/0	4	64	—	79
2/1	5	80	—	95
3/0	6	96	—	111
3/1	7	112	—	127
4/0	8	128	—	143
4/1	9	144	—	159

QPC215 Segmented Bus Extender Card and QPC441 Three Port Extender Card

Use this procedure to replace a QPC215 Segmented Bus Extender (SBE) Card or a QPC441 Three Port Extender (3PE) Card.

See the *XII input/output guide (553-3001-400)* for a description of all maintenance commands and system messages.

WARNING

UEM covers are *not* hinged; do *not* let go of the cover. Lift the cover away from the UEM and set it out of your work area.

Removing equipment

Note: The SBE Card is not used in system option 61. To replace a 3PE Card in system option 61, go directly to Step 2.

- 1 Software disable the SBE and 3PE:
 - The CPU associated with the SBE must be inactive. If you need to switch CPUs, enter
LD 35
SCPU
 - Disable the SBE by entering
DIS EXT xxx
(Table 7 lists extender codes specified by “xxx”)

Table?
Extender codes

Extender number	From	To
0G0	CPU 0	Network Group 0
0G1	CPU 0	Network Group 1
	CPU 0	Network Group 2
0G3	CPU 0	Network Group 3
0G4	CPU 0	Network Group 4
1G0	CPU 1	Network Group 0
1G1	CPU 1	Network Group 1
1G2	CPU 1	Network Group 2
1G3	CPU 1	Network Group 3
1G4	CPU 1	Network Group 4

- Set the **ENB/DIS** switch to DIS on the faceplate of the SBE or 3PE (whichever you are replacing).

CAUTION

To avoid interrupting service, set **ENB/DIS** switches to DIS before disconnecting or connecting cables.

- Tag and disconnect cables to the card you are removing.
- Unhook the locking devices on the car& pull it out of the card cage.

Installing equipment

- Set the **ENB/DIS** switch to DIS on the replacement card.
- Set option switches on the replacement card the same as on the card you removed. To check switch settings, see *Circuit pack installation and testing* (553-3001-211).

CAUTION

Incorrect switch settings on the SBE can cause a system failure.

-continued —

**QPC215 Segmented Bus Extender and QPC441 Three Port Extender
(continued)**

7 Insert the replacement card into the vacated slot and hook the locking devices.

8 Connect cables to the replacement card.

9 Set **the ENB/DIS** switch to ENB on **the** replacement card.

10 Software enable and test the newly installed card:

To test a 3PE Card in system option 61, enter

LD 35

TCPU

To enable and test SBE and 3PE Cards in system option 7 1, enter

ENL EXT xxx

TCPU

- When the process is complete, you will receive a system response.
- If there is a problem, a CED system message will be generated and the red LED will light on the faceplate of the appropriate card.
- End the session in LD 35 by entering

11 Tag defective **equipment** with a description of the problem and package it for return to a repair center.



QPC412 InterGroup Switch Card

Use this procedure to replace an **InterGroup** Switch (IGS) Card.

See the XII input/output guide (553-3001-400) for a description of all maintenance commands and system messages.



WARNING

UEM covers are **not** hinged, do **not** let go of the cover. Lift the cover away from the UEM and set it out of your work area.

Removing equipment

- 1 Software disable the IGS:
 - The associated CPU must be inactive. If you need to switch CPUs, enter
LD 35
SCPU
 - End the session in LD 30 by entering

 - Disable the IGS by entering
LD 39
DISI IGS xx
("xx" represents the IGS card number-0 to 19)
- 2 Set the **ENB/DIS** switch to DIS.

CAUTION

To avoid interrupting service, set **ENB/DIS** switches to DIS before disconnecting or connecting cables.

- 3 Tag and disconnect cables to the card you are removing.
- 4 Unhook the locking devices on the card pull it out of the card cage.



Installing equipment

- 5 Set the **ENB/DIS** switch to DIS on the replacement card.
- 6 Insert the replacement card into the vacated slot and hook the locking devices.
- 7 Connect cables to the replacement **card**.
- 8 Set the **ENB/DIS** switch to ENB on the replacement card.
- 9 Software enable and test the IGS by entering
ENL IGS xx
STAT IGS
 - When the process is complete, you will receive a system response.
 - If there is a problem, an ISR system message will be **generated** and the red LED will light on the faceplate of the card.
 - End the session in LD 39 by entering

- 10 Tag defective equipment with a description of the problem and package it for return to a repair center.

QPC471 and QPC775 Clock Controller Card.

Use this procedure to replace a QPC471 or QPC775 Clock Controller (CC) Card.

Note: The QPC775 Clock Controller is available in Canada only. QPC775 and QPC471 cards may not be combined in one system.

See the XII input/output guide (553-3001-400) for a description of all maintenance commands and system messages.

WARNING

UEM covers are **not** hinged; do not let go of the cover. Lift the cover away from the UEM and set it out of your work area.

Removing equipment

1 Disable the Clock Controller Card:

- The associated CPU must be inactive. If you need to switch CPUs, enter
LD 35
SCPU

End the session in LD 35 by entering

- The card you are removing must be inactive. If you need to switch the clock, enter
LD 39
SCLK
- Set the **NORM/MAINT** switch to MAINT on the **active** CPU.
- Disable the CC Card by entering
DIS SCG x
("x" represents the card number-0 or 1)

End the session in LD 39 by entering

- 2 Set the **ENB/DIS** switch to DIS on the card you are removing.

CAUTION

To avoid interrupting service, set **ENB/DIS** switch to DIS before disconnecting or connecting cables.

- 3 Tag and disconnect cables to the card you are removing.
- 4 Unhook the locking devices on the **card**; pull it out of the card cage.

Installing equipment

- 5 Set the **ENB/DIS** switch to DIS on the replacement card.
- 6 Set option switches on the replacement card the same as on the card **you** removed. To check switch **settings**, see **Circuit pack installation and testing** (553-3001-211).
- 7 Insert the replacement card into the vacated slot and hook the locking devices.
- 8 Connect the cable to the replacement card.
- 9 Set the **ENB/DIS** switch to ENB on the replacement card.
- 10 Enable and test the card:
 - Set the **NORM/MAINT** switch on both **CPUs** to **NORM**.
 - Switch **CPUs** by entering
LD 35
SCPU

End the session in LD 35 by entering

-continued —

QPC471 and QPC775 Clock Controller Card (continued)

- Test and switch the clock by entering
LD 39
ENL SCG x
SCLK

End the session in LD 39 by entering

If there is a problem, an ISR system message will be generated and the red LED will light on the faceplate of the card.

- 11 Tag defective equipment with a description of the problem and package it for return to a repair center.



119

QPC477 Bus Terminating Unit

Use **this** procedure to replace a Bus Terminating Unit (BTU).

See the XII input/output guide (553-3001-400) for a description of all maintenance commands and system messages.

WARNING

UEM covers are **not** hinged; do not let go of the cover. Lift the cover away from the UEM and set it out of your work area.

- 1 Gently pull the BTU out of the card cage. **See Circuit pack installation and testing (553-3001-211)** for BTU slot locations.
- 2 Insert the replacement BTU into the vacated slot.
- 3 Tag defective equipment **with** a description of the problem and package it for return to a repair center.



QPC513 and QPC841 Serial Data Interface Card

Use this procedure to replace a QPC513 or QPC841 Serial Data Interface (SDI) Card.

See the XII *input/output guide (553-3001-400)* for a description of all maintenance commands and system messages.

WARNING

UEM covers are not hinged; do not let go of the cover. Lift the cover away from the UEM and set it out of your work area.

CAUTION

If the system terminal is assigned to the SDI being replaced, assign it to another port before this SDI is disabled.

Removing equipment

- 1 Software disable each port on the SDI by entering
LD 37
DIS TTY x
("x" represents the number of the interface device attached to a port)
- 2 Set the ENB/DIS switch to DIS.

CAUTION

To avoid interrupting service, set ENB/DIS switches to DIS before disconnecting or connecting cables.

- 3 Tag and disconnect cables to the card you are removing.
- 4 Unhook the locking devices on the card pull it out of the card cage.

Installing equipment

- 5 Set the **ENB/DIS** switch to DIS on the replacement card.
- 6 Set option switches on the replacement card **the** same as on the card *you* removed. To check switch settings, *see Circuit pack installation and testing* (553-3001-211).
- 7 Insert the replacement card into the vacated slot and hook the locking devices.
- 8 Connect cables to the replacement card.
- 9 Set the **ENB/DIS** switch to ENB on the replacement card.
- 10 Software enable and test each port on the card by entering
ENL TTY
TTY
 - When the process is complete, you will receive a system response.
 - If there is a problem, an IOD system message will be generated and the red LED will light on the faceplate of the card.
 - End the session in LD 37 by entering

- 11 Tag defective equipment with a description of the problem and package it for return to a repair center.

QPC579 CPU Function Card

Use this procedure to replace a CPU Function (FN) Card,

See the XI1 input/output guide (553-3001-400) for a description of all maintenance commands and system messages.



WARNING

UEM covers are *not* hinged; do not let go of the cover. Lift the cover away from the UEM and set it out of your work area.

CAUTION

At some point in this procedure **the** system may initialize, causing a momentary interruption in call processing.

Removing equipment

- 1 Disable the Function Card you are replacing by disabling the associated QPC580 CPU Interface (IF) Card. This CPU must be inactive.
 - If you need to switch CPUs, enter
LD 35
SCPU
 - Set the **NORM/MAINT** switch to **MAINT** on the active Interface Card: (This keeps the system from switching to **the** inactive CPU.)
 - Set the **ENB/DIS** switch to **DIS** on the **inactive** Interface Card.
- 2 Disconnect the cable between the Function Card and the Interface Card.
- 3 Unhook the locking devices on the card pull it out of the card cage.



- 4 Gently unplug the QPC939 ROM Card from the connectors on the component side of the Function Card.

CAUTION

When you remove the ROM Card, do not touch other components on the Function Card.

Installing equipment

- 5 Plug the ROM Card into connectors on the component side on the replacement Function Card.
- 6 Insert the replacement Function Card into the vacated slot and hook the locking devices.
- 7 Connect the cable between the replacement Function Card and the Interface Card.
- 8 Enable the Function Card by enabling the Interface Card:
 - Set the **ENB/DIS** switch to ENB on the inactive Interface Card.
 - Set the **NORM/MAINT** switch to NORM on both Interface Cards.
- 9 Test the CPU by entering
TCPU
 - If there is a problem, a CED system message will be generated.
 - End the session in LD 35 by entering

- 10 Tag defective equipment with a description of the problem and package it for return to a repair center.

QPC580 CPU Interface Card

Use this procedure to replace a CPU Interface (**IF**) Card.

See the XII input/output guide (553-3001-400) for a description of all maintenance commands and system messages.

WARNING

UEM covers are *not* hinged, do *not* let go of the cover. Lift the cover away from the UEM and set it out of your work area.

CAUTION

At some point in this procedure the system may initialize, causing a momentary interruption in call processing.

Removing equipment

- 1 Disable the Interface Card. This CPU must be inactive.
 - If you need to switch CPUs, enter
LD 35
SCPU
 - Set the **NORM/MAINT** switch to **MAINT** on the active Interface Card. (This keeps the system from switching to the inactive CPU.)
 - Set the **ENB/DIS** switch to **DIS** on the *inactive* Interface Card (the one you are replacing).
- 2 Disconnect the cable between the Interface Card and the QPC579 CPU Function Card.
- 3 Unhook the locking devices on the card; pull it out of the card cage.

Installing equipment

- 4 Set the **ENB/DIS** switch to DIS on the faceplate of the replacement card.
- 5 Insert the replacement card into **the** vacated slot and hook the locking devices.
- 6 Connect **the** cable between the Interface Card and the Function Card.
- 7 Enable the Interface Card:
 - Set the **ENB/DIS** switch to ENB on the replacement card.
 - Set the **NCRM/MAINT** switch to NORM on both Interface Cards.
- 8 Test the CPU by entering **TCPU**
 - If there is a problem, a CED system message will be generated and the red LED will light on the faceplate of the card.
 - End the session in LD 35 by entering

- 9 Tag defective equipment with a description of the problem and package it for return to a repair center.

QPC581 Changeover and Memory Arbitrator Card

Use this procedure to replace a Changeover and Memory Arbitrator (CMA) Card.

See **the X11 input/output guide (553-3001-400)** for a description of all maintenance commands and system messages.



WARNING

UEM covers are not hinged; do **not** let go of the cover. Lift the cover away from the **UEM** and set it out of your work area.

CAUTION

At some point in this procedure the system may initialize, causing a momentary interruption in call processing.

Removing equipment

- 1 Software disable the CMA:
 - The associated CPU must be inactive. If you need to switch CPUs, enter
LD 35
SCPU
 - All Memory Cards served by the CMA must be disabled before the CMA can be disabled. For each Memory Card enter
DIS x
("x" represents a two-digit number-the **first** digit is the associated CPU Card and the second is the Memory Card number)
 - Disable the CMA by entering
DIS CMA x
("x" represents **the** CMA number-0 or 1)
- 2 Set the **ENB/DIS** switch to DIS on **the** CMA.



CAUTION

To avoid interrupting service, set **ENB/DIS** switches to DIS before disconnecting or connecting cables.

- 3 Tag and disconnect cables to the card you are removing.
- 4 Unhook the locking devices on the **card**; pull it out of the card cage.

Installing equipment

- 5 Set the **ENB/DIS** switch to DIS on the replacement card.
- 6 Insert the replacement card into **the** vacated slot and hook the locking devices.
- 7 Connect cables to the replacement card.
- 8 Set the **ENB/DIS** switch to ENB on the replacement card.
- 9 Software enable any cards that were disabled:
 - To enable the CMA enter
ENL CMA x
 - To enable each Memory Card enter
ENL x
- 10 Test the CMA by entering
TCPU
 - If there is a problem, a CED system message will be generated and the red LED will light on the faceplate of the card.
 - End the session in LD 35 by entering

- 11 Tag defective equipment with a description of the problem and package it for return to a repair center.

QPC583 Memory Card

Use this procedure to replace a Memory Card.

See the *X11 input/output guide (553-3001-400)* for a description of all maintenance commands and system messages.

WARNING

UEM covers are not hinged; do not let go of the cover. Lift the cover away from the UEM and set it out of your work area.

CAUTION

At some point in this procedure the system may initialize, causing a momentary interruption in call processing.

Removing equipment

- 1 Software disable the Memory Card:
 - The associated CPU must be inactive. If you need to switch CPUs, enter
LD 35
SCPU
 - All Memory Cards on this CPU must be disabled before the defective Memory Card is removed. For each Memory Card enter **DIS x** ("x" represents a two-digit number-the first digit is the associated CPU Interface Card and the second is the Memory Card number)

CAUTION

All Memory Cards on this CPU must be software disabled to avoid the possibility of a sysload.

- 2 Unhook the locking devices on the card pull it out of the card cage.

Installing equipment

- 3 Insert the replacement card into the vacated slot and hook the locking devices.
- 4 Test and enable Memory Cards:
 - Test the replacement card by **entering**
MEM x
 - When the process is complete, you will receive a system response.
 - Enable each disabled Memory Card by entering
ENL x
- 5 Test the CPU by entering
TCPU
 - If there is a problem with one of the Memory Cards, a CED system message will be generated and the red LED will light on the faceplate of the card.
 - End the session in LD 35 by entering

- 6 Tag defective equipment with a description of the problem and package it for return to a repair center.

QPC584 Mass Storage Interface Card and QPC742 Floppy Disk Interface Card

Use this procedure to replace a **QPC584** Mass Storage Interface (MSI) Card or **QPC742** Floppy Disk Interface (**FDI**) Card.

See the *XII input/output* guide (553-3001-400) for a description of all maintenance commands and system messages.

WARNING

UEM covers are not hinged; do not let go of the cover. Lift the cover away from the UEM and set it out of your work area.

Removing equipment

- 1 Disable the **MSI** or **FDI**:
 - The associated CPU must be inactive. If you need to switch **CPUs**, enter
LD 35
SCPU

End the session in LD 35 by entering

 - Software disable the **MSI** or **FDI** by entering
LD 37
DIS MSI x
("x" represents the **MSI** or **FDI** number)
 - Set the **ENB/DIS** switch to **DIS** on the faceplate of the **MSI** or **FDI**.

CAUTION

To avoid interrupting service, set **ENB/DIS** switches to **DIS** before disconnecting or connecting cables.

- 2 Tag and disconnect the cable to the card you are removing.
- 3 Unhook the locking devices on the card; pull it out of the card cage.

- 4 Remove **the** screw that secures the QMM42 Data Cartridge. Gently unplug the cartridge from the connectors on the component side of the **MSI** or **FDI**.

Installing equipment

- 5 Plug the Data Cartridge into **the** connectors on the component side of the replacement **MSI** or **FDI**. Install the screw that secures the cartridge.
- 6 Set the ENBPIS switch to DIS on the replacement card.
- 7 Set option switches on the replacement card the same as on the card you removed. To check switch settings, **see *Circuit pack installation and testing*** (553-3001-211).

CAUTION

Incorrect switch settings on an **MSI** or **FDI** can cause a system failure.

- 8 Insert **the** replacement card into the vacated slot and hook the locking devices.
- 9 Connect the cable to the replacement card.
- 10 Set the **ENB/DIS** switch to ENB on the replacement card.
- 11 Test the **MSI** or **FDI** by entering
MSI x
("x" represents the Multi Disk Unit or Floppy Disk Unit number)
 - If there is a problem, an IOD system message will be generated and the red LED will light on the faceplate of the card.
 - End the session in LD 37 by entering

- 12 Tag defective equipment with a description of the problem and package it for return to a repair center.

QPC659 Dual Loop Peripheral Buffer Card

Use this procedure to replace a Dual Loop Peripheral Buffer (DLB) Card.

See the *XII input/output* guide (553-3001-400) for a description of all maintenance commands and system messages.



WARNING

UEM covers are *not* hinged; do *not* let go of the cover. Lift the cover away from the **UEM** and set it out of your work area.

CAUTION

Service is interrupted when a loop is disabled.

Removing equipment

- 1 Software disable the Dual Loop Peripheral Buffer by entering
LD 32
DISS I s
(**"I s"** represents loop and shelf number)
- 2 Set the **ENB/DIS** switch to **DIS**.

CAUTION

To avoid interrupting service, set **ENB/DIS** switches to **DIS** before disconnecting or connecting cables.

- 3 Tag and disconnect cables to the card you are removing.
- 4 Unhook the locking devices on the card; pull it out of the card cage.



Installing equipment

- 5 Set the **ENB/DIS** switch to DIS on the replacement card.
- 6 Set option switches on the replacement card the same as on the card **you** removed. To check switch **settings, see Circuit pack installation and testing** (553-3001-211).
- 7 Insert the replacement card into the vacated slot and **hook** the locking devices.
- 8 Connect cables to the replacement card.
- 9 Set the **ENB/DIS** switch to ENB on the replacement card.
- 10 Software enable each loop on the card by entering
ENLS 1 s
 - When the process is complete, you will receive a system response.
 - End the session in LD 32 by entering

- 11 Test each loop on the card by entering
LD 30
LOOP loop
("loop" represents the loop number)
 - If there is a problem, an NWS system message will be generated and the appropriate red LED will light on the faceplate of the card.
 - End the session in LD 30 by entering

- 12 Tag defective equipment with a description of the problem and package it for return to a repair center.

QPC687 CPU Card

Use this procedure to replace the QPC687 CPU Card with **SDI/RTC**.

See the XII input/output guide (**553-3001-400**) for a description of all maintenance commands and system messages.

WARNING

UEM covers are *not* hinged; do *not* let go of the cover. Lift the cover away from the UEM and set it out of your work area.

CAUTION

Call processing will stop when the CPU Card is removed.

Removing equipment

- 1 If the Serial Data Interface (SDI) port is used, software disable it by entering
LD 37
DIS TTY x
("x" represents the number of the interface device attached to the port)
- 2 Disconnect the cable to the **SDI** port.
- 3 Unhook the locking devices on the card; pull it out of the card cage.
- 4 Gently unplug the QPC940 ROM Card from the connectors on the component side of the CPU Card.

CAUTION

When you remove the ROM Card, do not touch other components on the CPU Card.

Installing equipment

- 5 Plug the ROM Card into the connectors on the component side on the replacement CPU Card.

- 6 Set option switches and plugs on the replacement card the same as on the card you removed. To check switch settings, **see *Circuit pack installation and testing*** (553-3001-211).
- 7 Insert the replacement card into the vacated slot and hook the locking devices.
- 8 Connect the cable to the **SDI** port.
- 9 Software enable and test the **SDI** port by entering
ENL TTY
TTY
 - When the process is complete, you will receive a system response.
 - If **there** is a problem, an IOD system message will be generated and the red LED will light on the faceplate of the card.
 - End the session in LD 37 by entering

- 10 Tag defective equipment with a description of the problem and package it for return to a repair center.

QPC939 Read Only Memory Card

The QPC939 Read Only Memory (ROM) Card is attached to the QPC579 CPU Function (**FN**) Card. Use this procedure to replace a QPC939 ROM Card.

See the XII *input/output* guide (**553-3001-400**) for a description of all maintenance commands and system messages.

WARNING

UEM covers are not hinged; do *not* let go of the cover. Lift the cover away from the UEM and set it out of your work area.

CAUTION

At some point in this procedure the system may initialize, causing a momentary interruption in call processing.

Removing equipment

- 1 To replace the ROM Card you must disable and remove the Function Card. Disable the Function Card by disabling the associated **QPC580** CPU Interface (IF) Card.
 - This CPU must be inactive. If you need to switch **CPUs**, enter **LD 35**
SCPU
 - Set the **NORM/MAINT** switch to **MAINT** on the *active* Interface Card. (This keeps the system from switching to the inactive CPU.)
 - Set the **ENB/DIS** switch to **DIS** on the *inactive* Interface Card.
- 2 Disconnect the cable between the Function and Interface Cards.
- 3 Unhook the locking devices on the Function Card; pull it out of the card cage.

- 4 Gently unplug the ROM Card **from** the connectors on the component side of the Function Card.

C A U T I O N

When you remove the ROM Card, do not touch other components on the Function Card.

Installing equipment

- 5 Plug the replacement ROM Card into the connectors on the component side of the Function Card.
- 6 Reinsert the Function Card and hook the locking devices.
- 7 Connect the cable between the Function and Interface Cards.
- 8 Enable the Function Card by enabling the Interface Card.
 - Set the **ENB/DIS** switch to ENB on the inactive Interface Card.
 - Set the **NORM/MAINT** switch to NORM on both Interface Cards.
- 9 Test the CPU by entering
TCPU
 - If there is a problem, a CED system message will be generated.
 - End the session in LD 35 by entering

- 10 Tag defective equipment with a description of the problem and package it for return to a repair center.

QPC940 Read Only Memory Card

The **QPC940** Read Only Memory (ROM) Card is attached to the **QPC687** CPU Card. Use this procedure to replace a **QPC940** ROM Card.

See the *X11 input/output guide* (553-3001-400) for a description of all maintenance commands and system messages.

WARNING

UEM covers are *not* hinged; do *not* let go of the cover. Lift the cover away from the UEM and set it out of your work area.

CAUTION

At some point in this procedure the system may initialize, causing a momentary interruption in call processing.

Removing equipment

- 1 To replace **the** ROM Card you must remove the CPU Card. Unhook the locking devices on the CPU **Card**; pull it out of the card cage.
- 2 Gently unplug the ROM Card from the connectors on the component side of the CPU Card.

CAUTION

When you remove the ROM Card, do not touch other components on the CPU Card.

Installing equipment

- 3 Plug the replacement ROM Card into the connectors on the component side of **the** CPU Card.
- 4 Reinsert the CPU Card and hook the locking devices.
- 5 Tag defective equipment with a description of the problem and package it for return to a repair center.

Index

A

Air Probe Harness 62
 Analog Line Card 38
 Analog Message Waiting Line Card 38
 Asynchronous Interface Line Card 38

B

Blower Unit 66
 Bus Terminating Unit (BTU) 120

C

Changeover and Memory Arbitrator (CMA)
 Card 128
 Clock Controller (CC) Card 116
 Common Equipment Power Supply AC 30
 Common Equipment Power Supply DC 22
 Common/Peripheral Equipment Backplane 84
 Common/Peripheral Equipment Card Cage
 Assembly 84
 Common/Peripheral Equipment Power Supply
 AC 30
 Common/Peripheral Equipment Power Supply
 DC 22
Conference/TDS Card 42
 Controller Card-2 36
 Controller Card-4 36
 CPU Backplane 92
 CPU Card Cage Assembly 92
 CPU Card with **SDI/RTC** 136

CPU Function (**FN**) Card 124
 CPU Interface (IF) Card 126
 CPU/Network Backplane 16
 CPU/Network Card Cage Assembly 16

D

Data Cartridge 106
 Digital Line Card 38
Digitone Receiver Card 38
 Dual Loop Peripheral Buffer (DLB) Card 134

E

E&M Trunk Card 38

F

Fan Unit 34
 Floppy Disk Interface (**FDI**) Card 132
 Floppy Disk Unit (**FDU**). 80
 Four Port Digital Line Card 38

I

Intelligent Peripheral Equipment Backplane
 102
 Intelligent Peripheral Equipment Card Cage
 Assembly 102
InterGroup Switch (IGS) Card 114

M

Mass Storage Interface **(MSI)** Card 132
Memory Card 130
Memory/Peripheral Signaling Card 46
Modem Pool Line Card 38
Module Power Distribution Units **(MPDUs)**
76
Multi Disk Unit **(MDU)** 82

N

Network Backplane 96
Network Card 40
Network Card Cage Assembly 96
Network/DIR Card 44

P

Peripheral Equipment Backplane 88
Peripheral Equipment Card Cage Assembly
88
Peripheral Equipment Power Supply AC 30
Peripheral Equipment Power Supply DC 22
Peripheral Signaling Card 108
Power Distribution Unit 72
Power Distribution Unit **(PDU)** AC 68
Power Distribution Unit **(PDU)** DC 26
Power Fail Transfer Unit **(PFTU)** 50

R

Read Only Memory (ROM) Card 138,140
Rectifiers 24
Ringing Generator AC 30
Ringing Generator DC 22

S

Segmented Bus Extender (SBE) Card 110
Serial Data Interface (SDI) Card 122
Serial Data Interface (SDI) paddle board 52
Superloop Network Card 40

System Monitor 32, 48

T

Thermostat Harness 54
Three Port Extender (3PE) Card 110
Top Cap Fan 12

U

Universal Trunk Card 38



14-00000-1



SL-1

System options 21, 51, 61, 71

Hardware replacement

Copyright © 1990 Northern Telecom

All rights reserved.

Information subject to change without notice.

Release 1.0

Standard

January 29, 1990

Printed in U.S.A.



553-3001-250

SL-1

System options 21, 51, 61, 71

Upgraded systems installation

Standard

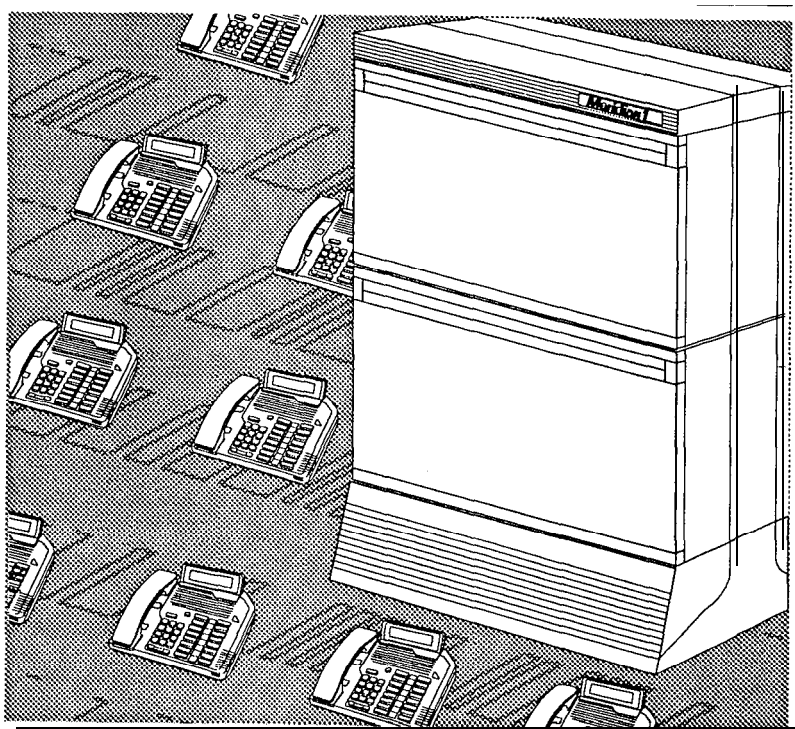

nt northern
talaam

Meridian 1
Communication Systems





SL-1

System options **21, 51, 61, 71**

Upgraded systems installation

Publication number: 553-3001-250

Document release: 2.0

Document status: Standard

Date: February 28, 1990

© 1990 Northern Telecom

All rights reserved.

Upgraded systems installation 553-3001-250

ii

Revision history

January 29, 1990

Standard, release 1.0

February 28, 1990

Standard, release 2.0

About this document

This document describes how to upgrade existing Meridian SL-1 systems to Meridian 1, and how to connect existing cabinets to Meridian 1 Modules.

The term Meridian I **Module** refers to an equipped Universal Equipment Module (UEM). A UEM is a modular, self-contained hardware cabinet that houses a card cage, power supply, backplane, circuit cards, and other basic equipment. When the UEM is equipped, it supports a system function and becomes a specific type of module, such as a CPU Module or Network Module.

References

See the *Planning & engineering guide* for

- *Muster index* (553-3001-000)
- *System overview* (553-3001-100)
- *Installation planning* (553-3001-120)
- *System engineering* (553-3001-151)
- *Power engineering* (553-3001-152)
- *Spares planning* (553-3001-153)
- *Equipment identification and ordering* (553-3001-154)

See the list of line and trunk circuit descriptions in *the Muster index* (553-3001-000) for specific references to lines and trunks.

See the *Installation and maintenance guide* for

- ***System installation procedures*** (553-3001-210)
- ***Circuit pack installation and testing*** (553-3001-211)
- ***Installation procedures for telephone sets and attendant consoles*** (553-3001-215)
- ***Upgraded systems installation*** (553-3001-250)
- ***Disk drive upgrade procedures*** (553-3001-251)
- ***General maintenance information*** (553-3001-500)
- ***Fault clearing*** (553-3001-510)
- ***Hardware replacement*** (553-3001-520)

See the *XI software guide* for an overview of software architecture, procedures for software installation and management, and a detailed description of all XI 1 features and services. This information is contained in two documents:

- ***XII software management*** (553-3001-300)
- ***XII features and services*** (553-3001-305)

See the *XI1 input/output guide* (553-3001-400) for a description of all administration programs, maintenance programs, and system messages.

Contents

Upgrading methods and requirements	1-1
Electromagnetic interference regulations	1-1
Upgrade paths	1-1
Common equipment in existing cabinet	1-1
Minimum system levels	1-1
Software and memory requirements	1-2
Mass storage requirements	1-2
Common equipment in modules	1-3
Network and peripheral equipment	1-3
Multi-group systems	1-4
Connector housings	1-4
Connector housings on cabinet side panel	1-4
Connector housings on cabinet top panel	1-4
Installing modules	1-5
Grounding requirements	1-5
System power sources	1-5
System monitoring	1-5
Monitoring connections between cabinets	1-6
<hr/>	
Equipment requirements	2-1
<hr/>	
Upgrading	3-1
Upgrading steps	3-1
<hr/>	
Mounting connector housings on cabinet top panel	4-1
Top panel connector housings	4-1

Mounting connector housings on cabinet side panels	5-1
Side panel connector housings	5-1
Tools required	5-1
<hr/>	
Connecting the System Monitor	6-1
<hr/>	
Connecting modules to existing cabinets	7-1
Cabinet equipped with a connector housing on its side panel	7-1
Cabinet equipped with a connector housing on its top panel	7-1
Cabinet not equipped with connector housings	7-2
<hr/>	
Connecting modules to ST-type cabinets	8-1
<hr/>	
Connecting modules to QCA60 cabinets	9-1
<hr/>	
Configuring for Meridian 1 operation	10-1



Upgrading methods and requirements

Electromagnetic interference regulations

Suppression of Electromagnetic Interference (**EMI**) as described in FCC regulation Part 15 Subpart J is a requirement in the USA. Only equipment designed to suppress **EMI** can be installed in the USA. Requirements in other countries may vary depending on local regulations. Where applicable, this document lists both types of equipment.

Upgrade paths

An existing Meridian SL-1 can be upgraded to Meridian 1 by either of the following two methods:

- reusing most of the common and network equipment in the **existing** cabinet and adding Intelligent Peripheral Equipment (IPE) Modules and additional Peripheral Equipment (**PE**) Modules
- installing Common Equipment (CE), IPE and additional PE Modules, and reusing the cabinets to house the PE being retained.

Common equipment in existing cabinet

Minimum system levels

When the existing cabinet is used to house the Meridian 1 CE, it must be at one of the following minimum system levels:

- ST
- RT
- NT
- XT

Note: When upgrading a Meridian Si-1 ST to a system option 21, the CE remains in the existing **cabinet**. The PE is contained in PE Modules.

Consult the documents associated with your existing system for instructions on how to upgrade hardware and software to one of the minimum **system** levels.

Software and memory requirements

The system must be equipped with a minimum of Generic XI 1 Release 15 software and compatible data and memory. Information about Read-Only Memory (ROM) circuit cards is contained in **Equipment identification and ordering** (553-3001-154).

Sufficient Ready-Access Memory (RAM) must be **available** to meet the requirements of the upgraded system. Information about memory calculations can be found in **System engineering** (553-3001-151) and the applicable controlled **release** bulletin for the version of software used.

Consult the documents associated with your existing **system** for instructions on how to upgrade hardware and software to one of the minimum **system** levels.

Mass storage requirements

Mass storage requirements must also be met.

An NT8D68 Floppy Disk Unit (which can be used with all system options) or NT8D69 Multi Disk Unit (which can be used with all system options except option 21) is always required for CE Modules They can also be used instead of a QMM38 mass storage unit in an existing cabinet.

Disk drive upgrading procedures are described in **Disk drive upgrades** (553-3001-25 1).

Common equipment in modules

Existing systems can be upgraded to Meridian 1 by installing new CE Modules and removing the existing CE from the cabinets. The cabinets can be used to house existing peripheral equipment that is being retained. Intelligent peripheral equipment and additional existing PE is installed in modules.

Network and peripheral equipment

Network slots capable of supporting QPC414 Network Cards are compatible with NT8D04 Superloop Network Card.

Superloops consist of conventional loops consecutively grouped in multiples of four, beginning with loop 0. The Superloop Network Card is inserted in one of the slots belonging to the group of four loops. The slot for the other two loops belonging to the superloop is not available for another Superloop or QPC414 Network Card since those loops are accessed by the Superloop Network Card through the backplane. The empty slot can be used for an Serial Data Interface (SDI) circuit card. See System *installation procedures* (553-3001-210) for network slot assignments in modules.

The new PE cannot be installed in existing shelves and must be installed in modules. There are two types of PE modules:

- Intelligent Peripheral Equipment (IPE) Module which houses IPE circuit cards
- Peripheral Equipment (PE) Module which houses PE circuit cards.

To meet Electromagnetic Interference (EMI) requirements, a shielded cable is used to extend network loops between the existing cabinets and the modules. The cables are connected at each end to connectors located as follows:

- on the Input/Output (I/O) panel at the rear of modules
- on the lower front cover of QCA60 cabinets
- on the I/O panel at the rear of tiered cabinets such as QCA136, QCA 137, QCA 147 and other similar type cabinets
- on connector housings located at the top I/O panel or in the cable entry openings on the side panel on all other types of cabinets

When EMI suppression is not required, a **conventional** network cable can be used instead of a shielded cable. The cable is connected directly to the equipment in the cabinet and is not routed through an I/O panel or connector housing. This method is not acceptable in the USA.

Multi-group systems

Because of cabling constraints, all network groups in an upgraded system option 71 must be installed either in the existing network cabinet or in modules, but not in both.

Connector housings

Connector housings are used on existing cabinets (such as QCA74 or QCA108 cabinets) to comply with EMI suppression requirements.

Connector housings on cabinet side panel

Cable entry openings on the side panel of existing cabinets must be equipped with connector housings if they are to be used to route cables between the cabinet and a module. Each housing can accommodate up to six cables.

Cabinets with side panels equipped with sliding rectangular cable entry opening covers and rectangular entry openings can be equipped with one or two connector housings on each cable entry opening being equipped.

Cabinets with side panels equipped with square cable entry opening covers and round entry openings can be equipped with one connector housing for each opening being equipped.

Connector housings on cabinet top panel

The top panel of some cabinets are equipped with a square duct access opening. This opening can be equipped with a connector housing capable of accommodating ten connectors.

Cabinets equipped with a top I/O panel can be equipped with up to eight connector housings, each capable of housing six connectors.

An additional connector housing, capable of housing three connectors, can be installed on the cabinet top I/O panel between an existing connector housing and the top panel. However, since rearrangement of existing wiring and cables may be required to install this housing, it should only be used

when there are no other positions available. In many cases a spare position can be created by rearranging the existing cables, or by moving **SDI** or Digital Trunk Interface (DTI) connectors mounted in the cover plate on a vacant position to another location (such as in the new connector housing).

Installing modules

Modules should be installed before attempting to upgrade the existing system. See **System installation** procedures (553-3001-210) for information about installing and testing modules.

Grounding requirements

The system ground for modules must be connected to the same single point ground source as the existing cabinets (such as at the ground window on an existing cabinet or in the **QBL15** battery distribution box).

Installation planning guide (553-3001-120), **Power engineering** (553-3001-152), and **System installation procedures** (553-3001-210) detail grounding requirements and connections for modules.

System power sources

Depending on the type of Meridian 1 equipment installed, it can be powered by either an AC or a DC power supply source. When a DC power supply is required, the excess capacity of an existing DC power source and reserve battery can be shared with the new equipment.

Power engineering (553-3001-152) details the power requirements and gives engineering guidelines for modules.

Power installation instructions for modules are detailed in **System installation procedures** (553-3001-210).

System monitoring

Each column of modules is equipped with a System Monitor capable of monitoring power supplies, temperature, blower operation, and various other items that are crucial to proper system operation.

A full description of the functions and operation of the System Monitor is found in **General maintenance information** (553-3001-500).

Monitoring connections between cabinets

The **alarm** cabling from existing cabinets equipped with **QPC84** or **QPC173** power monitors is reused to connect to the monitoring system provided with the modules.

An **NT8D46AX** cable is used to connect the monitoring functions between a **QCA137 PE** cabinet and a module. The **QCA136** and **QCA147 CE/PE** cabinets require an **NT8D46AY** cable.

When Meridian 1 common equipment is housed in an existing **CE** cabinet, an **SDI** port is required in the existing cabinet to connect to **the** master System Monitor in the module. See the installation manual for the existing system for **SDI** port installation instructions.

Installation instructions for System Monitors located in modules are contained in *System installation procedures* (553-3001-210).

Note: A master System Monitor in one module is always required.

Equipment requirements

Table 2-1 lists the equipment required to connect modules to existing SL-1 cabinets.

Table 2-1
Equipment list

Item	Description
PO696547 connector housing	Required to suppress EMI . This housing mounts on the side of cabinets equipped with openings in their side panels. One housing can accommodate up to six connectors.
PO697550 adapter bracket	Required to suppress EMI in an existing QCA60 cabinet. Used with a PO697559 mounting bracket and PO697707 cover panel.
PO697559 mounting bracket	Required to suppress EMI in an existing QCA60 cabinet. Used with a PO697550 adapter bracket and PO697707 cover panel.
PO697707 cover panel	Required to suppress EMI in an existing QCA60 cabinet. Replaces one of the front covers to accommodate PO697559 mounting bracket and PO697550 adapter bracket.
PO702380 connector housing	Required to suppress EMI . This housing mounts on the top of cabinets equipped with a top I/O panel. One housing can accommodate up to six connectors.
PO703846 three-position connector housing kit	Required to suppress EMI . This connector housing mounts on the top of cabinets equipped with a top I/O panel. It is used when there are no positions available in the I/O panel and can accommodate up to three connectors.

—continued—

Table 2-1
Equipment list (continued)

item	Description	
PO703905 adaptor panel	Required to suppress EMI . This panel mounts on the top of cabinets equipped with a square duct opening in its top panel. One adaptor panel can accommodate up to 10 connectors. Requires a PO703906 adaptor panel housing.	
20703906 adaptor panel housing	One housing is required with each PO703905 adaptor panel.	
PO703960 SDI adaptor plate kit	Required to suppress EMI . This kit contains one PO702381 adaptor plate and screws required to mount an SDI connector in any of the above connector housings.	
PO703961 DTI adaptor plate kit	Required to suppress EMI . This kit contains one PO702382 adaptor plate and screws required to mount a DTI connector in any of the above connector housings.	
NT8D46AX	This cable is used to connect the system monitoring in a QCA137 PE cabinet to the master System Monitor located in a module. The cable is 13.7 m (45 ft) long.	
NT8D46AY	This cable is used to connect the system monitoring in a QCA136 or QCA147 CE/PE cabinet to the master System Monitor located in a module. The cable is 13.7 m (45 ft) long.	
NT8D73 cable	Required to suppress EMI . This inter-cabinet cable is used to extend network loops between cabinets. It is available in the following lengths:	
Code	Length	Equivalent
NT8D73AD	1.8 m (6ft)	QCAD312A
NT8D73AF	3.6 m (12 ft)	QCAD312B
NT8D73AL	6.1 m (20 ft)	—
NT8D73AS	9.1 m (30 ft)	—
NT8D73AS	9.1 m (30 ft)	—
—continued—		

Table 2-1
Equipment list (continued)

Item	Description																		
NT8D86 cable	Required to suppress EMI . This intra-module cable is used to extend from the I/O panel to the assigned QPC414 Network Card or Dual Loop Peripheral Buffer (DLB) circuit card in the module .																		
	<table border="0"> <thead> <tr> <th data-bbox="646 377 702 399">Code</th> <th data-bbox="1005 377 1084 399">Length</th> </tr> </thead> <tbody> <tr> <td data-bbox="613 420 735 442">NT8D86AC</td> <td data-bbox="985 420 1097 442">1.5 m (5ft)</td> </tr> <tr> <td data-bbox="613 462 735 485">NT8D86AD</td> <td data-bbox="985 462 1097 485">1.8 m (6ft)</td> </tr> <tr> <th data-bbox="652 505 702 527">Code</th> <th data-bbox="1012 505 1084 527">Length</th> </tr> <tr> <td data-bbox="619 548 742 570">NT8D88AC</td> <td data-bbox="992 548 1110 570">1.5 m (5 ft)</td> </tr> <tr> <td data-bbox="619 590 742 613">NT8D88AD</td> <td data-bbox="992 590 1110 613">1.8 m (6ft)</td> </tr> </tbody> </table>	Code	Length	NT8D86AC	1.5 m (5ft)	NT8D86AD	1.8 m (6ft)	Code	Length	NT8D88AC	1.5 m (5 ft)	NT8D88AD	1.8 m (6ft)						
Code	Length																		
NT8D86AC	1.5 m (5ft)																		
NT8D86AD	1.8 m (6ft)																		
Code	Length																		
NT8D88AC	1.5 m (5 ft)																		
NT8D88AD	1.8 m (6ft)																		
NT8D91 cable	This cable is used to connect a Superloop Network Card directly to a Controller Card. It can be used within modules or between a module and an existing cabinet when suppression of EMI is not a requirement in the existing cabinet.																		
	<table border="0"> <thead> <tr> <th data-bbox="652 761 702 783">Code</th> <th data-bbox="1012 761 1084 783">Length</th> </tr> </thead> <tbody> <tr> <td data-bbox="619 804 735 826">NT8D91 AC</td> <td data-bbox="992 804 1110 826">1.2 m (4ft)</td> </tr> <tr> <td data-bbox="619 847 735 869">NT8D91 AD</td> <td data-bbox="992 847 1110 869">1.8 m (6 ft)</td> </tr> <tr> <td data-bbox="619 889 735 912">NT8D91AE</td> <td data-bbox="992 889 1110 912">2.4 m (8 ft)</td> </tr> <tr> <td data-bbox="619 932 735 954">NT8D91AF</td> <td data-bbox="992 932 1110 954">3 m (10 ft)</td> </tr> <tr> <td data-bbox="619 975 735 997">NT8D91AG</td> <td data-bbox="985 975 1110 997">3.6 m (12 ft)</td> </tr> <tr> <td data-bbox="619 1017 735 1040">NT8D91AJ</td> <td data-bbox="985 1017 1110 1040">4.8 m (16 ft)</td> </tr> <tr> <td data-bbox="619 1060 735 1082">NT8D91AP</td> <td data-bbox="985 1060 1110 1082">7.6 m (25 ft)</td> </tr> <tr> <td data-bbox="619 1103 735 1125">NT8D91 AV</td> <td data-bbox="985 1103 1110 1125">13.7 m (45 ft)</td> </tr> </tbody> </table>	Code	Length	NT8D91 AC	1.2 m (4ft)	NT8D91 AD	1.8 m (6 ft)	NT8D91AE	2.4 m (8 ft)	NT8D91AF	3 m (10 ft)	NT8D91AG	3.6 m (12 ft)	NT8D91AJ	4.8 m (16 ft)	NT8D91AP	7.6 m (25 ft)	NT8D91 AV	13.7 m (45 ft)
Code	Length																		
NT8D91 AC	1.2 m (4ft)																		
NT8D91 AD	1.8 m (6 ft)																		
NT8D91AE	2.4 m (8 ft)																		
NT8D91AF	3 m (10 ft)																		
NT8D91AG	3.6 m (12 ft)																		
NT8D91AJ	4.8 m (16 ft)																		
NT8D91AP	7.6 m (25 ft)																		
NT8D91 AV	13.7 m (45 ft)																		
NT8D92AB cable	This intra-module cable is used to extend from the I/O panel to the assigned Controller Card in the module.																		
—continued—																			

Table 2-1
Equipment list (continued)

Item	Description																					
NT8D98 cable	Required to suppress EMI . This inter-cabinet cable is used to extend loops between cabinets. It is available in the following lengths:																					
	<table border="0"> <thead> <tr> <th data-bbox="556 380 613 403">Code</th> <th data-bbox="913 380 992 403">Length</th> </tr> </thead> <tbody> <tr> <td data-bbox="523 423 646 445">NT8D98AD</td> <td data-bbox="896 423 1005 445">1.8 m (6 ft)</td> </tr> <tr> <td data-bbox="523 466 646 488">NT8D98AF</td> <td data-bbox="885 466 1005 488">3.6 m (12 ft)</td> </tr> <tr> <td data-bbox="523 508 646 531">NT8D98AL</td> <td data-bbox="885 508 1005 531">6.1 m (20 ft)</td> </tr> <tr> <td data-bbox="523 551 646 573">NT8D98AS</td> <td data-bbox="885 551 1005 573">9.1 m (30 ft)</td> </tr> </tbody> </table>	Code	Length	NT8D98AD	1.8 m (6 ft)	NT8D98AF	3.6 m (12 ft)	NT8D98AL	6.1 m (20 ft)	NT8D98AS	9.1 m (30 ft)											
Code	Length																					
NT8D98AD	1.8 m (6 ft)																					
NT8D98AF	3.6 m (12 ft)																					
NT8D98AL	6.1 m (20 ft)																					
NT8D98AS	9.1 m (30 ft)																					
NT9J96 cable	Required to suppress EMI . This intra-cabinet cable is used in existing cabinets (except ST type cabinets) to extend an existing network loop from the connector housing to its assigned circuit card in the cabinet. It is available in the following lengths:																					
	<table border="0"> <thead> <tr> <th data-bbox="475 722 531 744">Code</th> <th data-bbox="705 722 784 744">Length</th> <th data-bbox="942 722 1047 744">Equivalent</th> </tr> </thead> <tbody> <tr> <td data-bbox="444 765 563 787">NT9J96AC</td> <td data-bbox="659 765 823 787">1015 mm (40 in.)</td> <td data-bbox="929 765 1067 787">QCAD311 A4</td> </tr> <tr> <td data-bbox="444 807 563 830">NT9J96AD</td> <td data-bbox="659 807 823 830">1780 mm (70 in.)</td> <td data-bbox="929 807 1067 830">QCAD311A5</td> </tr> <tr> <td data-bbox="444 850 563 872">NT9J96AE</td> <td data-bbox="652 850 823 872">2160 mm (85 in.)</td> <td data-bbox="929 850 1067 872">QCAD311 A6</td> </tr> <tr> <td data-bbox="444 893 563 915">NT9J96AG</td> <td data-bbox="679 893 797 915">3.6 m (12 ft)</td> <td data-bbox="988 893 1008 915">—</td> </tr> <tr> <td data-bbox="444 935 563 958">NT9J96AH</td> <td data-bbox="679 935 797 958">4.2 m (14 ft)</td> <td data-bbox="988 935 1008 958">—</td> </tr> <tr> <td data-bbox="444 978 563 1000">NT9J96AJ</td> <td data-bbox="679 978 797 1000">4.8 m (16ft)</td> <td data-bbox="988 978 1008 1000">—</td> </tr> </tbody> </table>	Code	Length	Equivalent	NT9J96AC	1015 mm (40 in.)	QCAD311 A4	NT9J96AD	1780 mm (70 in.)	QCAD311A5	NT9J96AE	2160 mm (85 in.)	QCAD311 A6	NT9J96AG	3.6 m (12 ft)	—	NT9J96AH	4.2 m (14 ft)	—	NT9J96AJ	4.8 m (16ft)	—
Code	Length	Equivalent																				
NT9J96AC	1015 mm (40 in.)	QCAD311 A4																				
NT9J96AD	1780 mm (70 in.)	QCAD311A5																				
NT9J96AE	2160 mm (85 in.)	QCAD311 A6																				
NT9J96AG	3.6 m (12 ft)	—																				
NT9J96AH	4.2 m (14 ft)	—																				
NT9J96AJ	4.8 m (16ft)	—																				
NT9J97 cable	Required to suppress EMI . This intra-cabinet cable is used in existing cabinets (except ST-type cabinets) to extend a superloop from the connector housing to its assigned circuit card in the cabinet. It is available in the following lengths:																					
—continued—																						

Table 2-1
Equipment list (continued)

Item	Description														
	<table border="1"> <thead> <tr> <th data-bbox="618 269 734 298">Code</th> <th data-bbox="953 269 1081 298">Length</th> </tr> </thead> <tbody> <tr> <td data-bbox="618 315 734 341">NT9J97AC</td> <td data-bbox="953 315 1120 341">1015 mm (40 in.)</td> </tr> <tr> <td data-bbox="618 358 734 384">NT9J97AD</td> <td data-bbox="953 358 1120 384">1780 mm (70 in.)</td> </tr> <tr> <td data-bbox="618 401 734 427">NT9J97AE</td> <td data-bbox="953 401 1120 427">2160 mm (85 in.)</td> </tr> <tr> <td data-bbox="618 444 734 469">NT9J97AG</td> <td data-bbox="953 444 1094 469">3.6 m (12 ft)</td> </tr> <tr> <td data-bbox="618 486 734 512">NT9J97AH</td> <td data-bbox="953 486 1094 512">4.2 m (14ft)</td> </tr> <tr> <td data-bbox="618 529 734 555">NT9J97AJ</td> <td data-bbox="953 529 1094 555">4.8 m (16ft)</td> </tr> </tbody> </table>	Code	Length	NT9J97AC	1015 mm (40 in.)	NT9J97AD	1780 mm (70 in.)	NT9J97AE	2160 mm (85 in.)	NT9J97AG	3.6 m (12 ft)	NT9J97AH	4.2 m (14ft)	NT9J97AJ	4.8 m (16ft)
Code	Length														
NT9J97AC	1015 mm (40 in.)														
NT9J97AD	1780 mm (70 in.)														
NT9J97AE	2160 mm (85 in.)														
NT9J97AG	3.6 m (12 ft)														
NT9J97AH	4.2 m (14ft)														
NT9J97AJ	4.8 m (16ft)														
<p>NT9J98 cable</p>	<p>Required to suppress EMI. This intra-cabinet cable is used in ST-type cabinets to extend an existing network loop from the I/O panel to its assigned circuit card in the cabinet. It is available in the following lengths:</p> <table border="1"> <thead> <tr> <th data-bbox="566 700 631 725">Code</th> <th data-bbox="798 700 875 725">Length</th> <th data-bbox="1030 700 1133 725">Equivalent</th> </tr> </thead> <tbody> <tr> <td data-bbox="540 742 656 768">NT9J98AC</td> <td data-bbox="747 742 914 768">1015 mm (40 in.)</td> <td data-bbox="1017 742 1146 768">QCAD311 A1</td> </tr> <tr> <td data-bbox="540 785 656 811">NT9J98AD</td> <td data-bbox="747 785 914 811">1780 mm (70 in.)</td> <td data-bbox="1017 785 1146 811">QCAD311 A2</td> </tr> <tr> <td data-bbox="540 828 656 854">NT9J98AE</td> <td data-bbox="747 828 914 854">2160 mm (85 in.)</td> <td data-bbox="1017 828 1146 854">QCAD311 A3</td> </tr> </tbody> </table>	Code	Length	Equivalent	NT9J98AC	1015 mm (40 in.)	QCAD311 A1	NT9J98AD	1780 mm (70 in.)	QCAD311 A2	NT9J98AE	2160 mm (85 in.)	QCAD311 A3		
Code	Length	Equivalent													
NT9J98AC	1015 mm (40 in.)	QCAD311 A1													
NT9J98AD	1780 mm (70 in.)	QCAD311 A2													
NT9J98AE	2160 mm (85 in.)	QCAD311 A3													
<p>NT9J99 cable</p>	<p>Required to suppress EMI. This intra-cabinet cable is used in ST-type cabinets to extend a superloop from the I/O panel to its assigned circuit card in the cabinet. It is available in the following lengths:</p> <table border="1"> <thead> <tr> <th data-bbox="644 999 708 1024">Code</th> <th data-bbox="1004 999 1081 1024">Length</th> </tr> </thead> <tbody> <tr> <td data-bbox="618 1041 734 1067">NT9J99AC</td> <td data-bbox="953 1041 1120 1067">1015 mm (40 in.)</td> </tr> <tr> <td data-bbox="618 1084 734 1110">NT9J99AD</td> <td data-bbox="953 1084 1120 1110">1780 mm (70 in.)</td> </tr> <tr> <td data-bbox="618 1127 734 1152">NT9J99AE</td> <td data-bbox="953 1127 1120 1152">2160 mm (85 in.)</td> </tr> </tbody> </table>	Code	Length	NT9J99AC	1015 mm (40 in.)	NT9J99AD	1780 mm (70 in.)	NT9J99AE	2160 mm (85 in.)						
Code	Length														
NT9J99AC	1015 mm (40 in.)														
NT9J99AD	1780 mm (70 in.)														
NT9J99AE	2160 mm (85 in.)														
<p>QCAD1 24 cable</p>	<p>This cable is used to connect a QPC414 Network Card directly to a QPC659 DLB Card. It can be used within modules or between a module and an existing cabinet when suppression of EMI is not a requirement in the existing cabinet.</p>														



Upgrading

Upgrading steps

Use the following steps to upgrade an existing system:

- 1 Upgrade the existing system to the minimum system level (if it is not presently at that level). Consult the documents associated with your existing system for instructions on how to upgrade to one of the minimum system levels.
- 2 Install connector housings on cabinets (they are required for EMI suppression). See the chapter entitled **Mounting connector housings on cabinet top panel** (page 4-1) or **Mounting connector housings on cabinet side panel** (page S-1) as appropriate.
- 3 Install the modules according to **System installation procedures** (553-3001-210). Connect the grounds to the same single point ground as the existing system.
- 4 Install the System Monitor connections between the existing cabinets and the modules. See the chapter entitled **Connecting System Monitor** (page 6-1).
- 5 Install the network loop cables within and between the cabinets and the modules. See the chapter entitled **Connecting modules to existing cabinets** (page 7-1), **Connecting modules to ST-type cabinets** (page 8-1) or **Connecting modules to QCA60-type cabinet** (page 9-1) as appropriate.
- 6 Configure the system through software for Meridian 1 operation. See **Configuring for Meridian 1 operation** (page 10-1).
- 7 Test the equipment as described in **System installation procedures** (553-3001-210).



Mounting connector housings on cabinet top panel

This chapter describes the method used to mount connector housings on the top panel of cabinets equipped with cable entry cutout or an I/O panel.

Top panel connector housings

Network cables can be routed through a connector housing on the top of cabinets equipped with an I/O panel.

Three types of connector housings can be installed on the top of a cabinet. Figures 4-1, 4-2, and 4-3 show the types of housings and how they are mounted on the top panel.

Mounting instructions for the three types of housings are given in Procedures 4-1, 4-2, and 4-3.

Refer to Figure 4-1 while following the steps in this procedure.

CAUTION

Do not drop screws or other hardware through the openings in the top panel when installing or assembling the various items in this procedure.

Procedure 4-1

Mounting a connector housing on a slotted cable access opening in the top I/O panel

- 1** Remove the cover from the selected access opening on the I/O panel. Keep the four screws.
- 2** Perform this step only if there are SDI or DTI cables connected to the access opening cover.

Relocate the SDI or DTI cables in another connector assembly on the top panel. If the cables are to be installed in the new connector housing, install a PO703960 (for SDI) or PO703961 (for DTI) adaptor plate kit on the cable and mount it in the new housing. See Figure 4-4.

- 3** Fasten the new housing to the I/O panel with the screws removed from the access opening cover.
- 4** Route cables to be installed in the connector housing through the housing to the inside of the cabinet.
- 5** Secure the connectors to the connector housing with the hardware provided.
- 6** Install cable racks or support brackets for inter-cabinet cables.

Note: Some type of support for the inter-cabinet cables may be required to remove stress from the connectors and the cabinet top panel. See *System engineering* (553-3001-151) for more information.

Figure 4-1
Top connector housing on slotted cable access opening

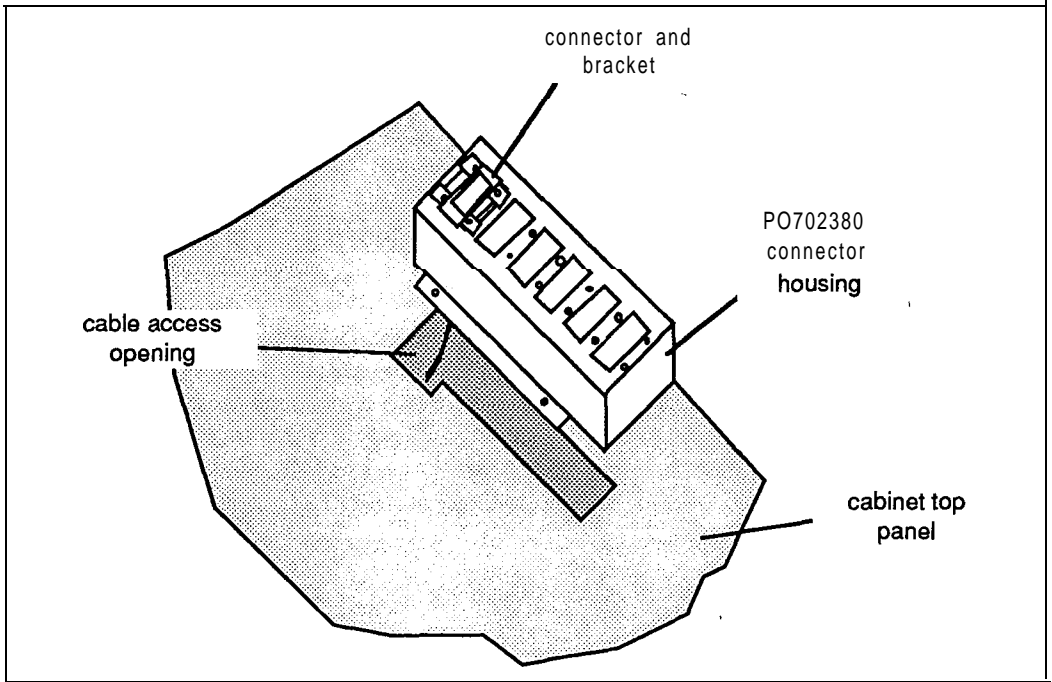

Refer to Figure 4-2 while following the steps in this procedure.

CAUTION

Do not drop screws or other hardware through the openings in the top panel when installing or assembling the various items in this procedure.

Procedure 4-2

Mounting a connector housing on an 110 panel without spare positions

- 1 Locate the existing connector housing that will be equipped with the new connector housing. Make sure that sufficient slack is provided in the cables that are connected to the existing housing. This housing will be raised approximately 75 mm (3 in.) in order to install the new housing. If necessary, remove the tie wraps securing the cables.
- 2 Remove and retain the screws securing the existing connector housing.
- 3 Route cables to be installed in the new connector housing through the connector housing panel towards the inside of the panel. Secure the cables to the panel with the hardware provided.
- 4 Raise the existing connector assembly and route the new cables through the cables access opening.
- 5 Fasten the connector housing panel to the I/O panel with two screws removed from the existing connector housing.
Slide the connector housing cover into place. Secure it to the I/O panel with two screws removed from the existing connector housing.
- 6 Place the existing connector housing on the studs located on the top of the new connector housing and secure it with the nuts and washers provided.

Figure 4-2
Additional top connector housing on slotted access opening

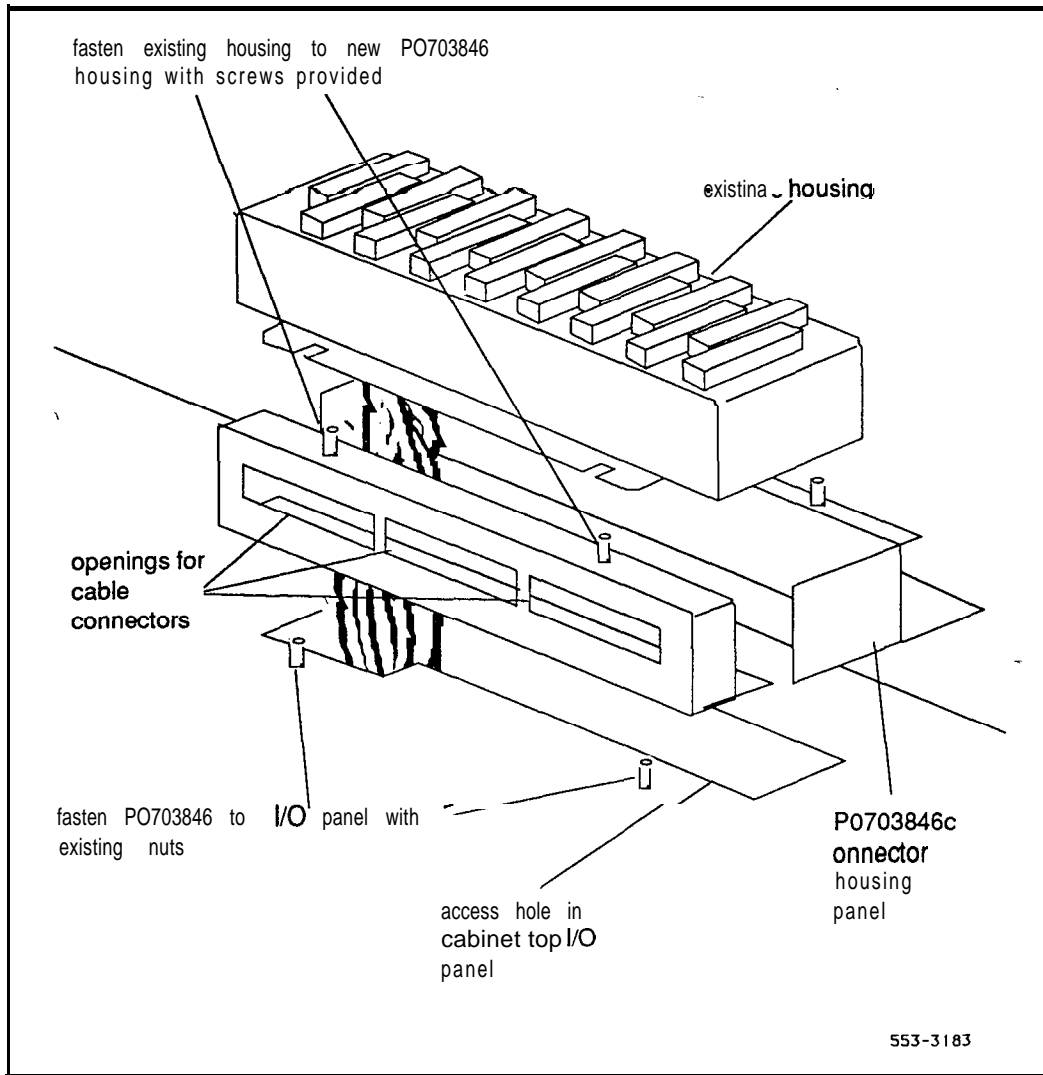

CAUTION

Do not drop screws or other hardware through the openings in the top panel when installing or assembling the various items in this procedure.

Procedure 4-3

Mounting a connector housing on a square duct access opening in the top panel

- 1 Remove the cover from the square duct access opening located in the cabinet top panel. Keep the nuts and washers to mount the new connector housing.
- 2 Route cables to be installed in the new connector housing through the connector housing panel towards the inside of the panel.
Secure the cables to the panel with the hardware provided.
- 3 Route the cables through the duct access opening.
- 4 Secure the panel to the two studs closest to the center of the cabinet top panel.

Slide the housing into place and secure with two nuts and washers.

Note: Refer to Figure 4-3 while following the steps in this procedure.

Figure 4-3
Top connector housing on square duct access opening

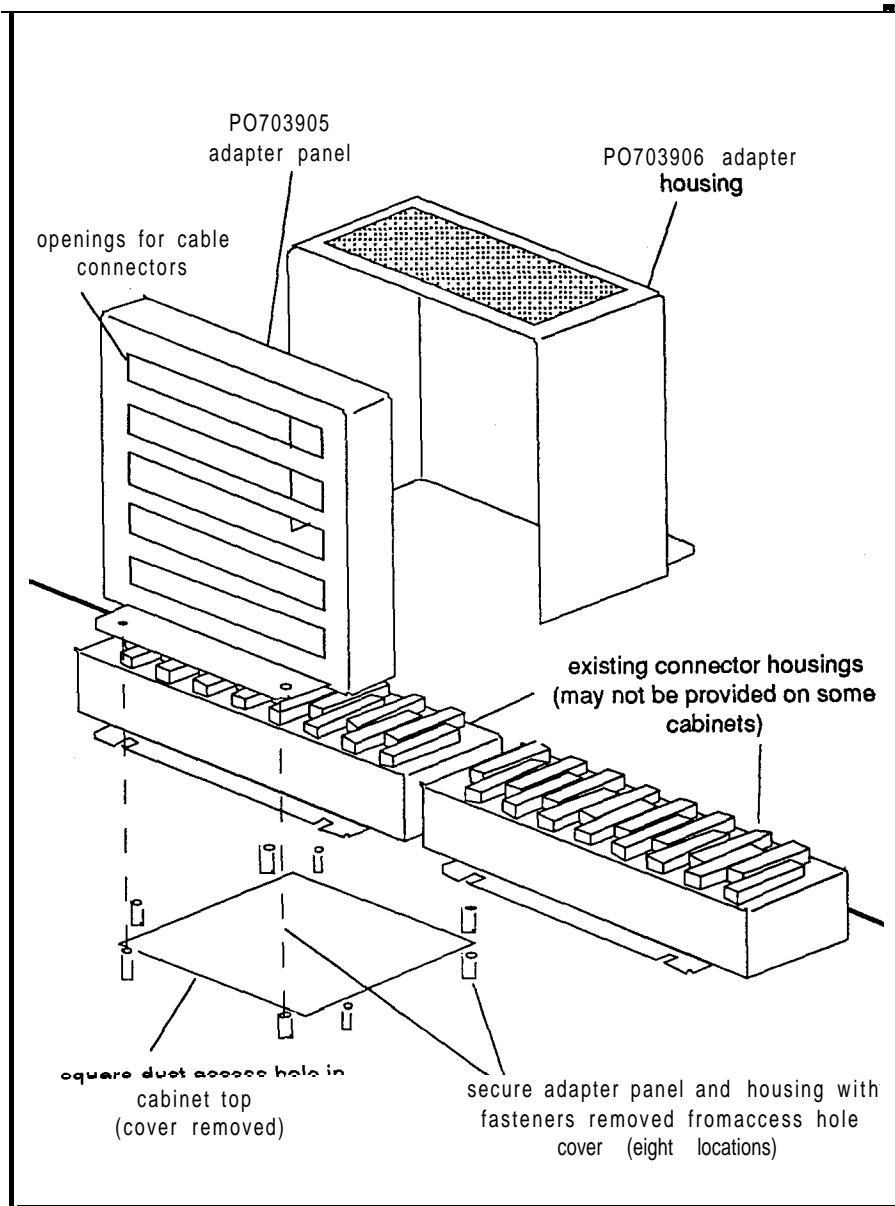
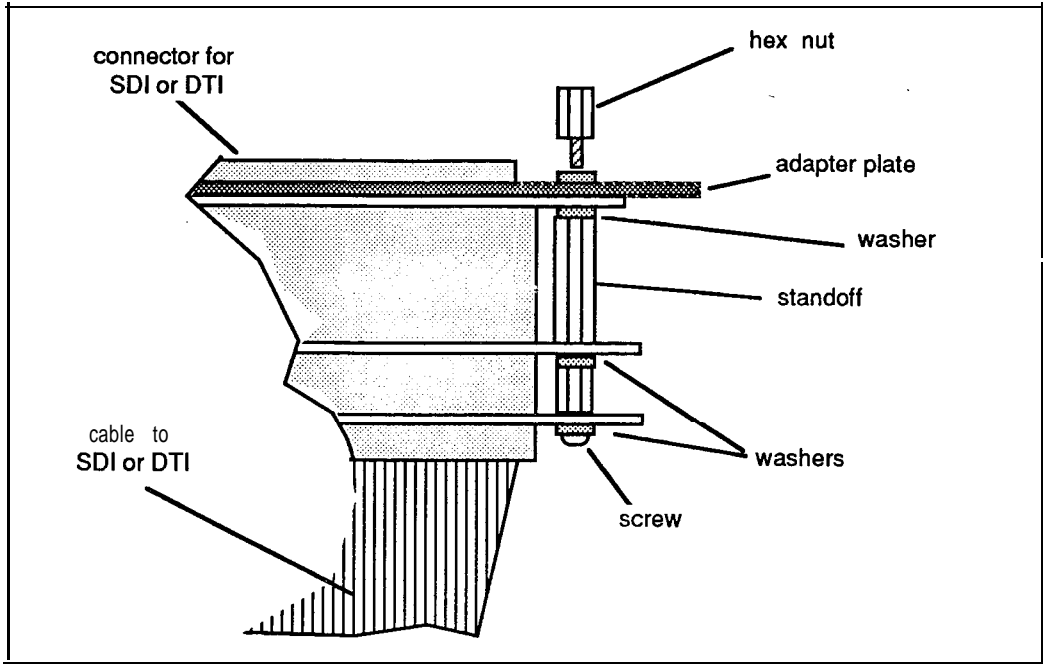

Figure 4-4
Adapter plate mounting bracket for SDI or DTI connectors



Mounting connector housings on cabinet' side panels

General information

This chapter describes the method used to mount connector housings on the side panels of cabinets equipped with cable entry cutouts.

Side panel connector housings

Cabinet side panels equipped with sliding rectangular cable entry opening covers and rectangular **entry** openings can be equipped with one or two connector housings for each cable entry opening being equipped.

Cabinet side panels equipped with square cable entry opening covers and round entry openings require one connector housing for each opening being equipped.

Holes must be drilled in the side panel to mount the connector housing.

Instructions on drilling the holes in the side panel are given in Procedure 5- 1.

Tools required

The following tools are required:

- a drill and a # 3 1 (. 120) bit capable of piercing sheet metal
- a center punch and hammer

Procedure 5-1

Drilling Holes for mounting the connector housing

- 1 Remove the sliding or square (whichever is equipped) cover over the cable entrance opening at the bottom of the side panel on the cabinet.

- 2 Perform this step only if the opening is rectangular shaped..

Place the housing against the the side panel centered over the cutout area.

If the opening is to be equipped with two housings, lower the housing until its upper edge falls in the horizontal center of the cutout. One inch of the upper part of the cutout should be visible as shown in Figure 5-1.

Mark the hole centers using the housing holes as a pattern. Center punch and drill the holes.

If the opening is to be equipped with two housings, temporarily mount **the** first housing and rest the second one on top of the first.

Center punch and drill the holes for the second housing.

Remove the housings from the cabinet side panel.

- 3 Perform this step only if the opening is round shaped.

Measure a point 22 mm ($7/8$ in.) from the edge of the panel at the front and rear ends of the side panel.

Mark a vertical line 64 mm ($2\ 1/2$ in.) long starting at 75 mm (3 in.) from the bottom edge of the panel.

Place the connector housing centered over the cable entrance opening. Gently move the housing until the pencil line is located in the center of one set of the housing mounting holes.

Level the housing and mark the hole centers using the housing mounting holes as a pattern. Center punch and drill the holes. See Figure 5-1.

- 4 Mount the housing and secure to the side panel with four # 6 sheet metal screws.

Note: The housing must be removed temporarily when installing the cables between the cabinet and the modules.

Figure 5-1
Rectangular shaped access opening

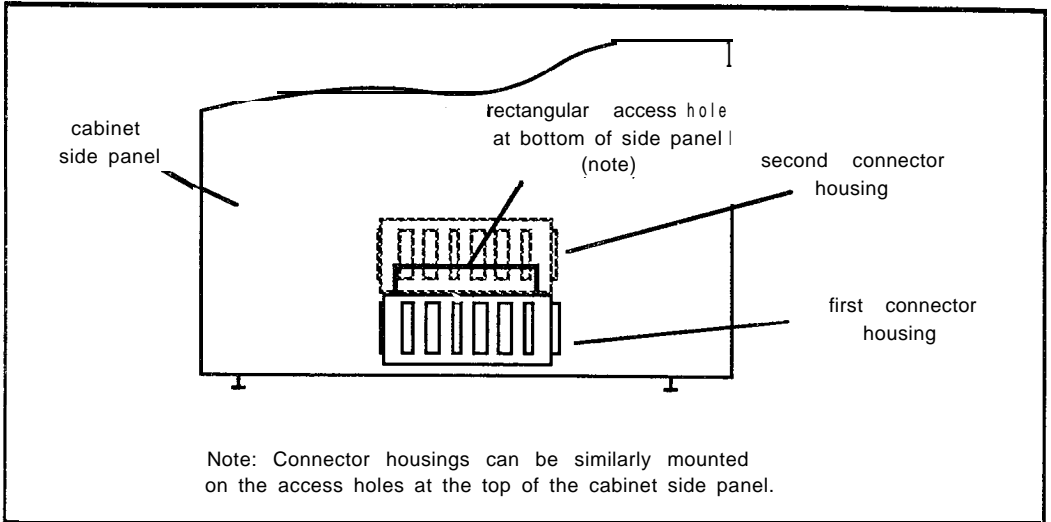
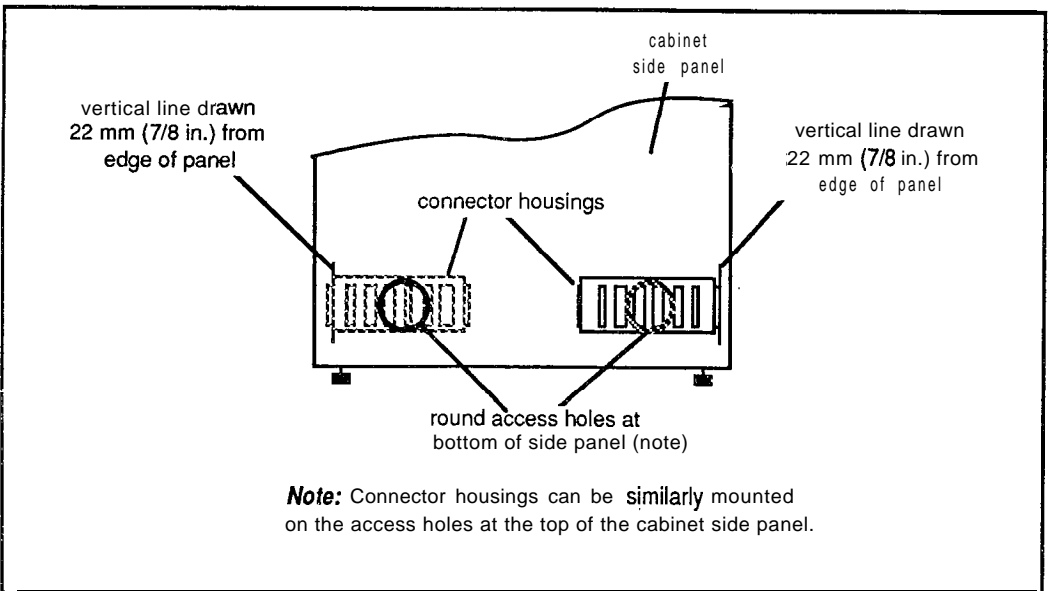

Figure 5-2'
Round access openings



5-4 Mounting connector housings on cabinet side panels



Connecting the System Monitor

General information

This chapter describes how to connect the System Monitor in the modules to the power monitors in the existing system.

The procedures are:

- Procedure 6-1 describes how to connect the System Monitors when existing Common Equipment (CE) and cabinets equipped with QPC84 or QPC173 power monitors (NT and XT systems, and QCA60-type cabinets) are to be used in the upgrade.
- Procedure 6-2 describes how to connect the System Monitors when the CE is located in a module and the remaining existing cabinets are equipped with QPC84 power monitors.
- Procedure 6-3 describes how to connect the System Monitors to cabinets equipped with QPC704 power monitors (ST and RT systems).

Procedure 6-1
Connecting System Monitor — CE remains in the existing cabinet
equipped with a **QPC84** (typically an NT) or **QPC173** (typically an XT)
power monitor

Note: During this procedure, use Figure 6-1 if the CE cabinet is equipped with a QPC84 power monitor. Use Figure 6-2 if the CE cabinet is equipped with a QPC 173 power monitor.

- 1 Make sure that the **NT8D46AH** alarm cable from connector J3 at the rear of the pedestal housing the master System Monitor is terminated at the cross-connect terminal. See the chapter entitled **System monitor cabling in the System installation procedures** (553-3001-210) for information about installing this cable.
- 2 At the cross-connect terminal, locate the **P10** cable from each existing cabinet.
 - Make sure that the SYSLTIN connections (**OW** wire) in all **P10** cables are connected together and to the **SYSLTOUT** connection (**WO** wire) on the **P10** cable from the CE cabinet. See Figure 6-1 or Figure 6-2.
 - Make sure that the CE-ALARM connections (**VBI** wire) in all **P10** cables are connected together. See Figure 6-1 or Figure 6-2.
- 3 Locate a -48 V source at the cross-connect terminal. Connect it to the MDFO-48 connection (green wire) on the **NT8D46AH** cable from the master module. See Figure 6-1 or Figure 6-2.
- 4 At the cross connect terminal, locate the SYSLTIN (blue wire) and CE-SYSLT (white wire) connections in the **NT8D46AH** cable from the master module.
 - Connect the SYSLTIN connection (**blue** wire) on the **NT8D46AH** alarm cable to the SYSLTOUT (**WO** wire) connection on the **P10** cable from the CE cabinet. See Figure 6-1 or Figure 6-2.

Connect the CE-SYSLT connection (white wire) on the **NT8D46AH** alarm cable to the CE-ALARM connection (**OW** wire) on the **P10** cable from the CE cabinet. See Figure 6-1 or Figure 6-2.

—continued—

- 5 Refer to the installation manual for the existing system and install an **SDI** port. This port will be used to connect to the module containing the master System Monitor and should be set for 1200 baud operation.
- 6 Check the switch settings on the System Monitors in the modules. Make sure that switch SW1 on all System Monitors is set according to Table 6-1. **See *Circuit puck installation and testing*** (553-3001-211) to set switches SW2 and SW3.

Note: The System Monitors in modules should be installed and connected as described in ***System installation procedures*** (553-3001-210). The first module installed should contain the master System Monitor. Other modules contain slave System Monitors. A master System Monitor is always required.

- 7 Install an NT8D46AD cable from connector P1 in the pedestal containing the master System Monitor to J1 on the backplane. Mount the SDI connector on the cable in an available opening in the I/O panel. See Figure 6-6 and ***System monitor cabling*** in the ***System installation procedures*** (553-3001-210) for information about installing this cable and connector.
- 8 Install an SDI cable from the SDI port on the existing CE cabinet to the SDI connector on the NT8D46AD cable in the I/O panel on the module. See Figure 6-1 or Figure 6-2.

Procedure 6-2

Connecting System Monitor — CE in a module and remaining existing cabinets are equipped with QPC84 power monitors

- 1 Make sure that the NT8D46AH alarm cable from connector J3 at the rear of the pedestal housing the master System Monitor is terminated at the cross-connect terminal. See the chapter entitled **System monitor cabling** in *the System installation procedures* (553-3001-210) for information about installing this cable.
- 2 At the cross-connect terminal, locate the P10 cable from each existing cabinet.
 - Make sure that the SYSLTIN connections (OW wire) in all P10 cables are connected together. See Figure 6-3.
 - Make sure that the CE-ALARM connections (VBI wire) in all P10 cables are connected together. See Figure 6-3.
- 3 Locate a ground source at the cross-connect terminal. Connect it to the MDF0-48 connection (green wire) on the NT8D46AH cable from the master module. See Figure 6-1 or Figure 6-2.
- 4 At the cross-connect terminal, locate the CEALMIN (orange wire) and CE-SYSLT (white wire) connections in the NT8D46AH cable from the master module.
 - Connect the CEALMIN connection (orange wire) on the NT8D46AH alarm cable to the CE-ALARM (VBL wire) connection on the P10 cable from the CE cabinet. See Figure 6-3.
 - Connect the CE-SYSLT connection (white wire) on the NT8D46AH alarm cable to the SYSLTIN connection (OW wire) on the P10 cable from the CE cabinet. See Figure 6-3.
- 5 Check the switch settings on the System Monitors in the modules. Make sure that switch SW1 on all System Monitors is set according to Table 6-1. See *Circuit pack installation and testing* (553-3001-211) to set switches SW2 and SW3.

Note: The System Monitors in modules should be installed and connected as described in *System installation procedures* (553-3001-210).

Procedure 6-3**Connecting System Monitor — The existing cabinet is equipped with a QPC704 power monitor**

Note: During this procedure, use Figure 6-4 if the CE is installed in the module. Use Figure 6-5 if the CE is installed in the same cabinet as the QPC704 power monitor.

- 1 Select the appropriate cable:
 - an NT8D46AX cable if the CE is installed in the module. See Figure 64.
 - an NT8D46AY cable if the CE is installed in the existing cabinet. See Figure 6-5.
- 2 Connect one end of the cable to connector 0 located at **the** lower rear of the existing cabinet.

Note: Connector 0 is located in **the first** of three openings located at the lower rear of the cabinet (the opening furthest from the edge). On some cabinets it is labeled **ALO**.

- 3 Connect the remaining connector on the cable to connector J3 at the rear of the pedestal containing the master System Monitor.
- 4 This step applies only when the CE is located in the existing cabinet with the QPC704 power monitor.

Refer to the installation manual for the existing system and install an **SDI** port. This port will be used to connect to the module containing the master System Monitor and should be set for 1200 baud operation.

-continued-

- 5 Check the switch settings on the System Monitors in the modules. Make sure that switch SW1 on all System Monitors is set according to Table 6-1. **See *Circuit puck installation and testing*** (553-3001-211) to set switches SW2 and SW3.

Note: The System Monitors in modules should be installed and connected as described in ***System installation procedures*** (553-3001-210). When the CE is installed in an existing cabinet and the modules contain only PE, the first module installed should contain the master System Monitor. Other modules contain slave System Monitors. A master System Monitor is always required.

- 6 This step applies only when the CE is located in the existing cabinet with the QPC704 power monitor.

Install an NT8D46AD cable from connector P1 in the pedestal containing the master System Monitor to J1 on the backplane. Mount the SDI connector on the cable in an available opening in the I/O panel. See Figure 6-6 and ***System monitor cabling in the System installation procedures*** (553-3001-210) for information about installing this cable and connector.

- 7 This step applies only when the CE is located in the existing cabinet with the QPC704 power monitor.

Install an SDI cable from the SDI port on the existing CE cabinet to the SDI connector on the NT8D46AD cable in the I/O panel on the module. See Figure 6-5.

Figure 6-1
Common equipment in existing cabinet equipped with a QPC84 power monitor

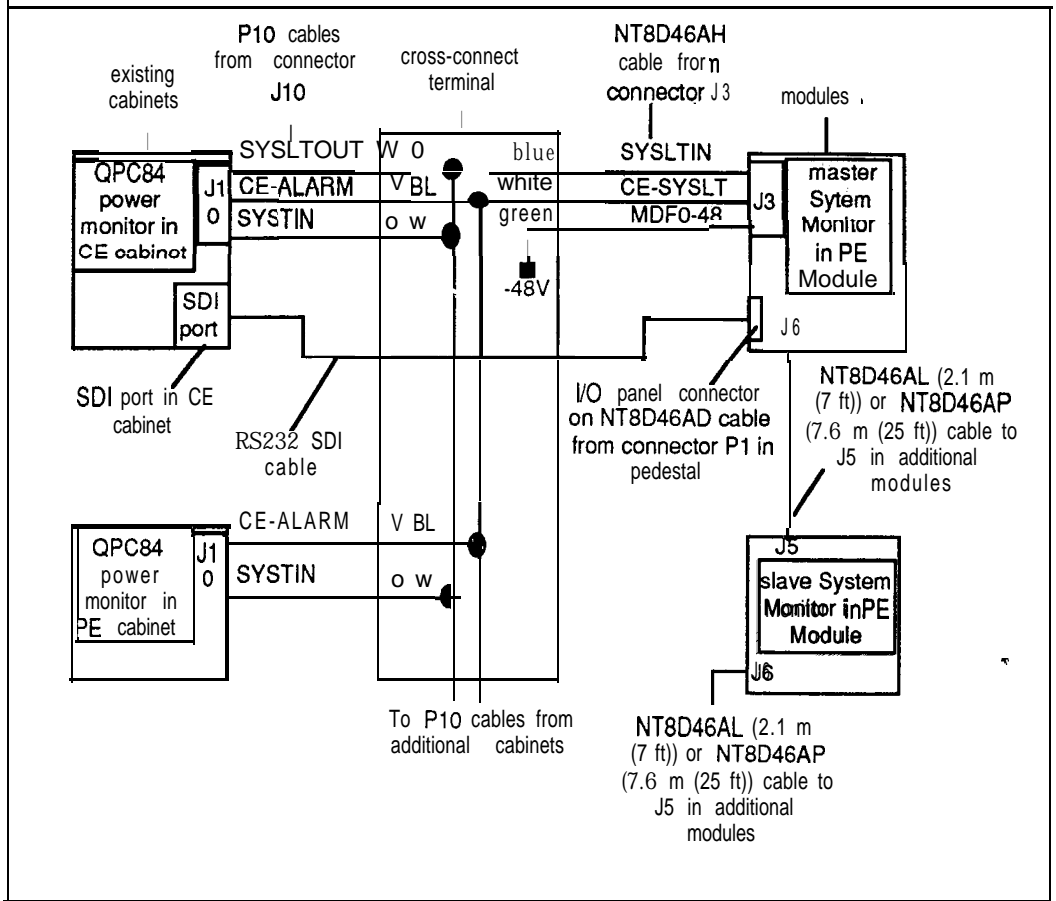

Figure 6-2
Common equipment in existing cabinet equipped with a QPC173 power monitor

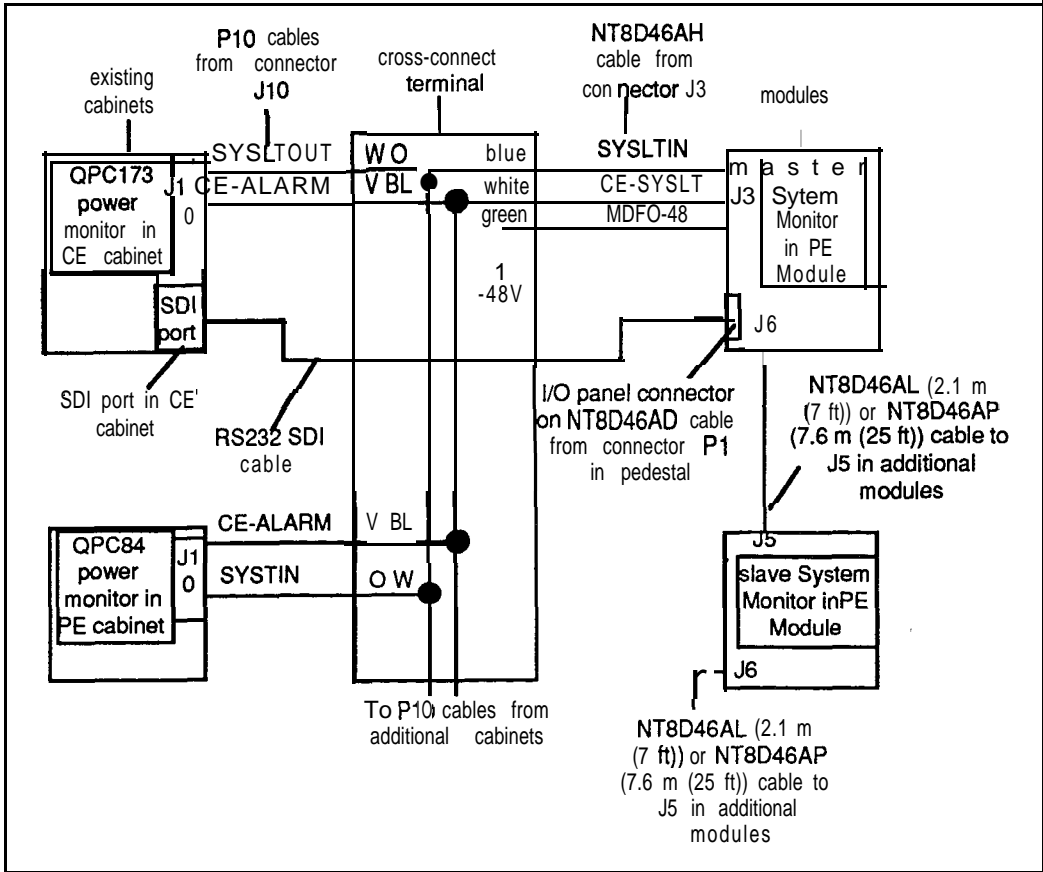

Figure 6-3
Common equipment in module and existing cabinets equipped with QPC84 power monitors

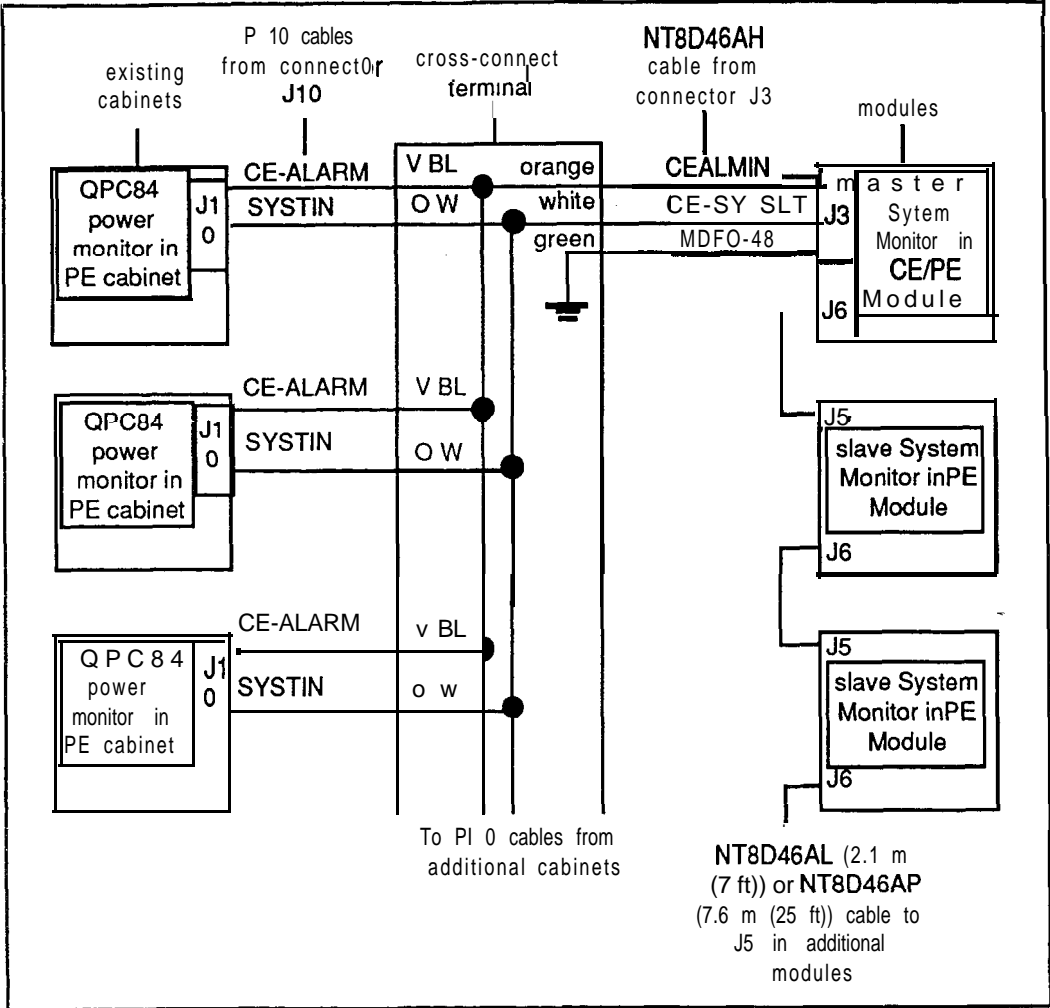

Figure 6-4
Common equipment in module and existing cabinet equipped with a QPC704 power monitor

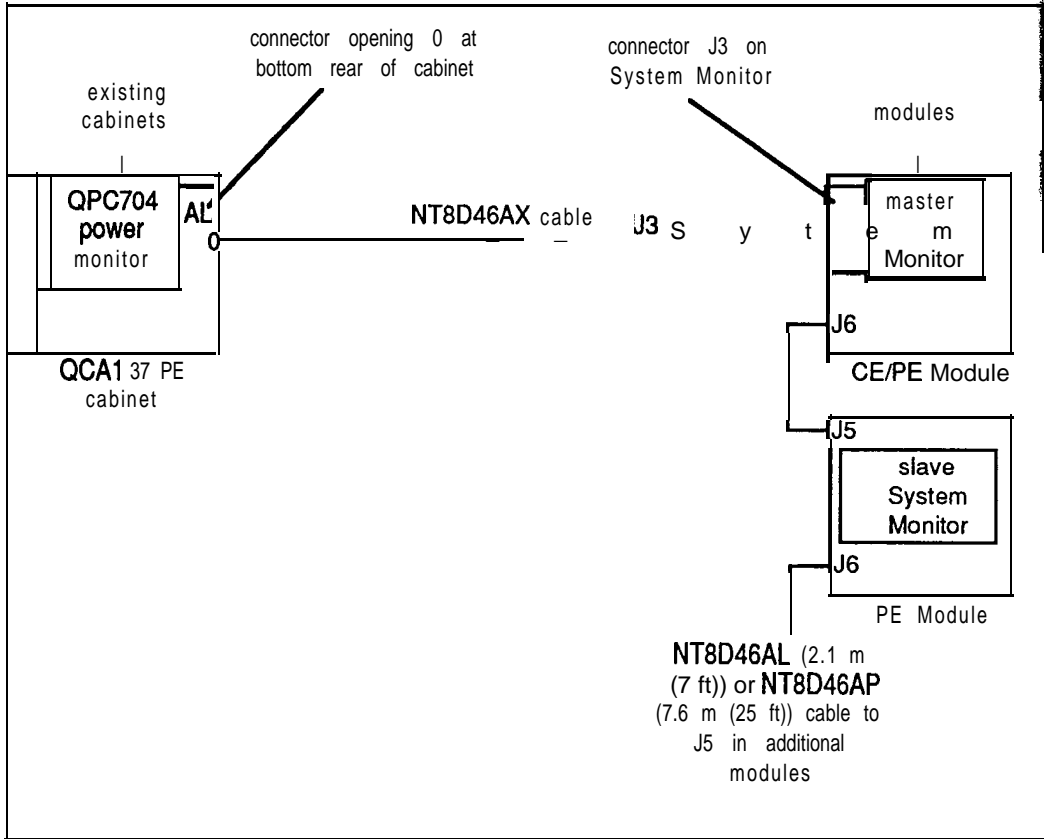

Figure 6-5

Common equipment in existing cabinet equipped with a QPC704 power monitor

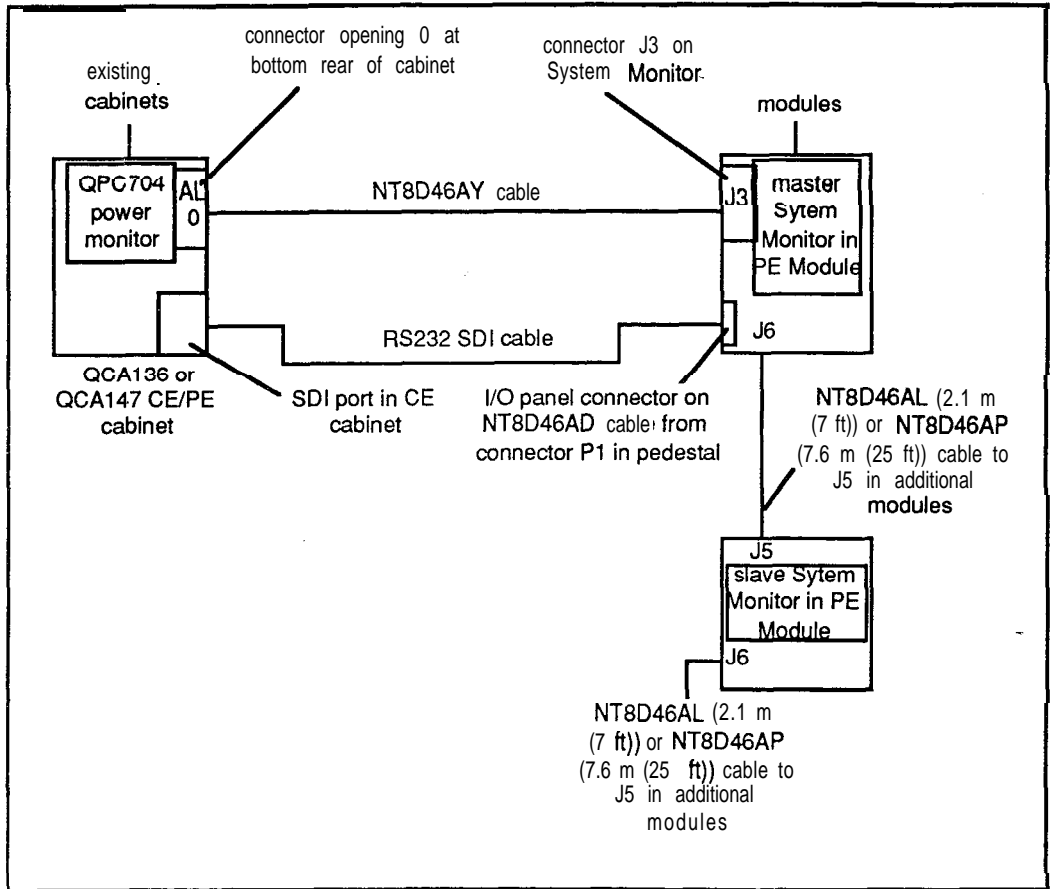

Figure 6-6
NT8D46AD cable connections

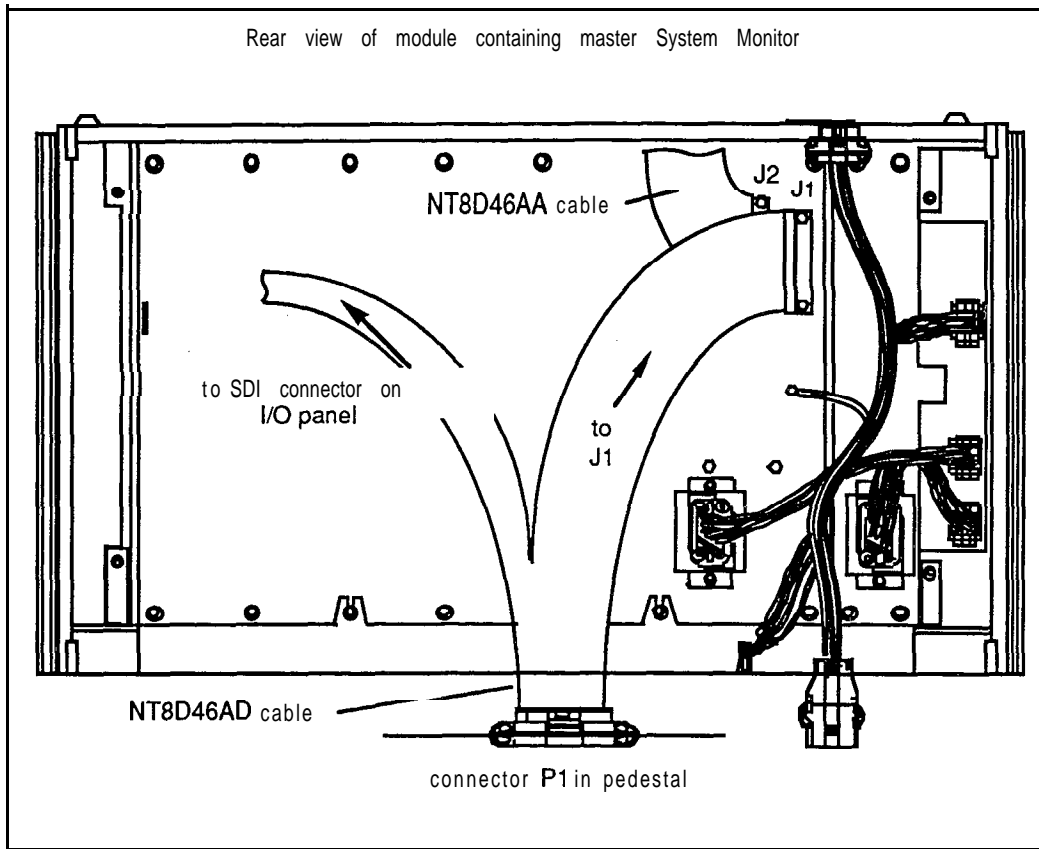

Table 6-1
SW1 System Monitor switch settings for upgraded systems

SW1	SETTING	FUNCTION
1	ON	Is co-located with an existing system containing a QPC84, QPC173, or QPC704 power monitor.
	OFF	Is not co-located with an existing system.
2	ON	This is the master System Monitor — is located in column containing a CPU and is connected to an existing system containing a QPC84, QPC173, or QPC704 power monitor.
	OFF	Set to OFF on all slave System Monitors.
	OFF	Switch 1 is set to ON and modules contain only Peripheral Equipment (PE)
	OFF	Is not co-located with an existing system containing a QPC84, QPC173 or QPC704 power monitor (switch is set to OFF).
3	ON	The entire system is DC- powered.
	OFF	The modules are AC-powered.
4	ON	The Power Fail Transfer Unit (PFTU) activates when overheating occurs.
	OFF	The PFTU will not be activated if overheating occurs.
5	ON	Is co-located with a system containing a QPC704 power monitor (such as an ST and RT system).
	OFF	Is co-located with a system containing a QPC84 or a QPC173 power monitor (such as an NT or XT system).
	OFF	Is not co-located with an existing system containing a QPC84, QPC173, or QPC704 power monitor (switch is set to OFF).
6	ON	Is co-located with a system containing a QPC704 power monitor (such as an ST and RT system).
	OFF	Is co-located with a system containing a QPC84 or a QPC173 power monitor (such as an NT or XT system).
	OFF	Is not co-located with an existing system containing a QPC84, QPC173, or QPC704 power monitor (switch is set to OFF).
— continued —		

Table 6-1

SW1 System Monitor switch settings for upgraded systems (continued)

SW1	SETTING	FUNCTION
7	ON	Is co-located with a system containing a QPC84 or a QPC173 power monitor (such as an NT or XT system) and the modules contain only PE (the CE is in an existing cabinet).
	OFF	Is co-located with an existing system containing a QPC84, QPC173, or QPC704 power monitor and the CPU is in a module.
	ON	Is co-located with a system containing a QPC704 power monitor (such as an ST and RT system) and the modules contain only PE.
	OFF	The PE and CE are located in modules only. There are no existing cabinets associated with this system.
8	OFF	Is co-located with a system containing a QPC84 or a QPC173 power monitor (such as an NT or XT system) and the modules contain only PE (the CE is in an existing cabinet).
	ON	Is co-located with an existing system containing a QPC84, QPC173, or QPC704 power monitor and the CPU is in a module.
	ON	Is co-located with a system containing a QPC704 power monitor (such as an ST and RT system) and the modules contain only PE.
	OFF	The PE and CE are located in modules only. There are no existing cabinets associated with this system.

Connecting modules to existing cabinets

General information

This chapter describes how to install and connect wiring between existing cabinets (cabinets equipped with cable access openings at the top or side) and modules.

The types of cables required and their routing is shown in Figure 7-1 (EMI applications) and Figure 7-2 (non EMI applications).

Cabinet equipped with a connector housing on its side panel

When the existing cabinet is subject to EMI regulations and the network cables between the cabinet and a module are to be routed through the side panel of the cabinet, a connector housing must be installed on one of the side panel cable access openings. See the chapter ***Mounting connector housings on cabinet side panels*** (page 5-1) for information about installing the connector housing if one is not already installed.

Procedure 7-1 describes the installation of network cables on cabinets equipped with connector housings on the side panel.

Cabinet equipped with a connector housing on its top panel

When the existing cabinet is subject to EMI regulations and the network cables between the cabinet and a module are to be routed through the top of the cabinet, a connector at the top of the cabinet is required for each cable being installed. The connector can be mounted in the existing I/O panel (if one is provided) or in a connector housing. See ***Mounting connector housings on cabinet top panel*** (page 4-1) if a housing is required on the top panel. Refer to the installation manual for the existing system if a connector must be added to the existing I/O top panel or connector housing assembly to accommodate the new network loop.

When the connector housing is located on-the top panel of the existing cabinet, the connections between the cabinet and the module consists of installing the network cable between the assigned connectors on the cabinet top panel and the assigned connectors on the module as shown in Figure 7-1. Controller Card and Superloop Network Card connecting information is contained in *the System installation procedures* (553-3001-210).

Cabinet not equipped with connector housings

When suppression of EMI is not a requirement on the existing cabinet, the connections between the cabinet and the module consists of installing the network cable between the Superloop Network Card or QPC414 Network Card and the Controller Card or DLB Card as shown in Figure 7-2. Controller Card and Superloop Network Card connecting information is contained in *System installation procedures* (553-3001-210).

Figure 7-1
Cable types and their routing -Common equipment in existing cabinet or in a module (EMI suppression applications)

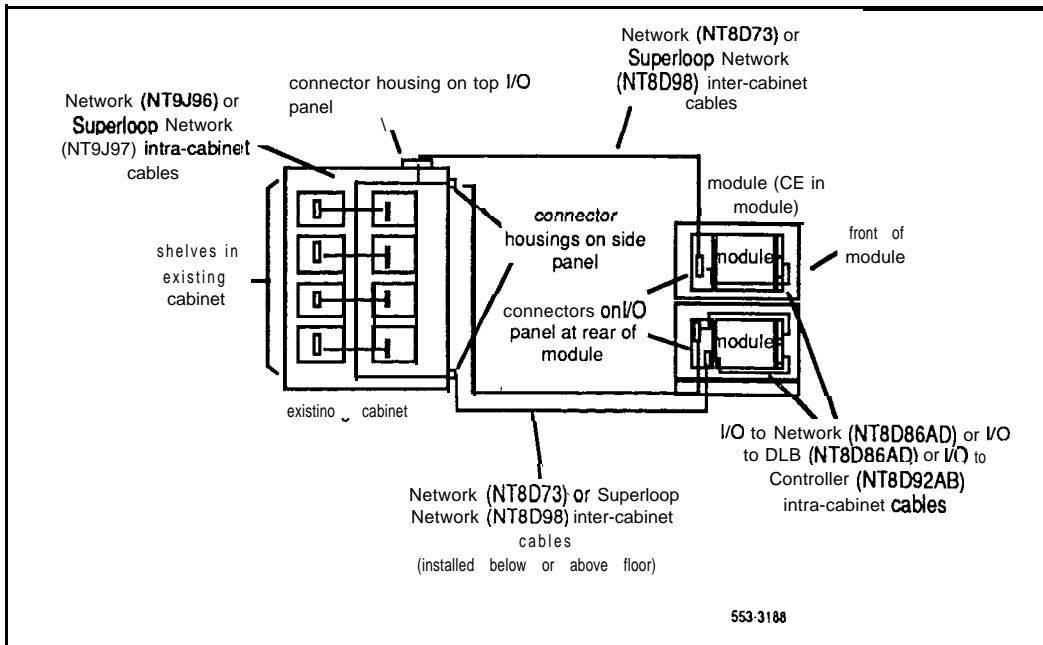
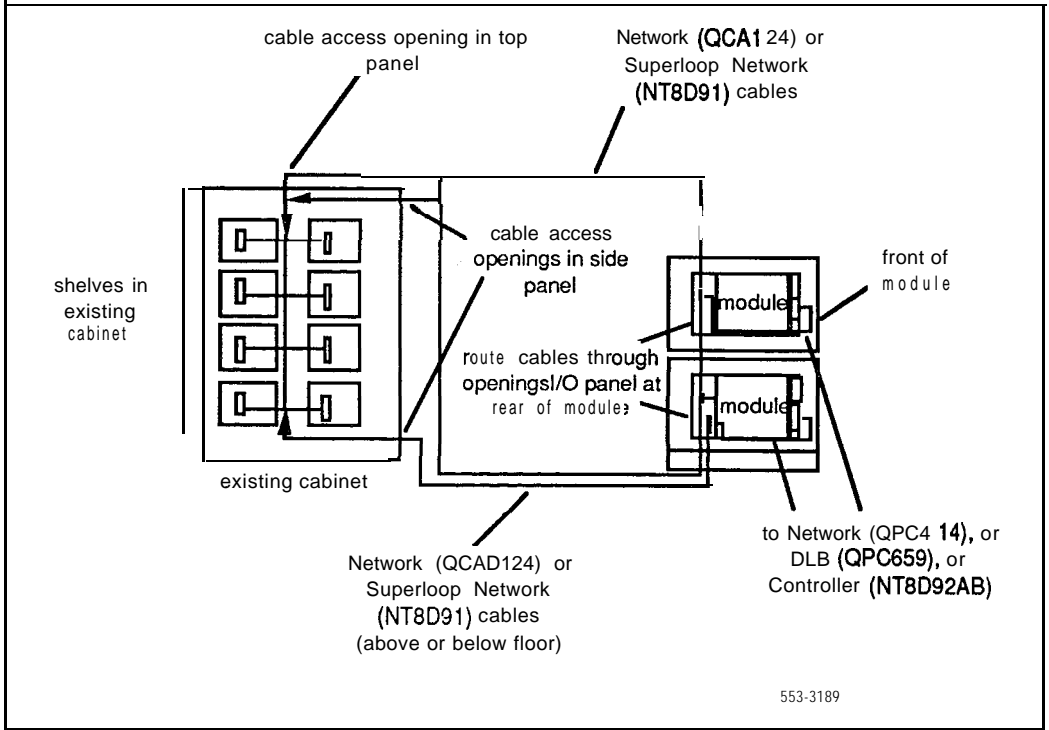

Figure 7-2
Cable types and their routing — Common equipment in existing cabinet or in a module (non-EMI suppression applications)



Procedure 7-1

Connecting to cabinets equipped with side panel connector housing

Note: Before starting this procedure, make sure that the screw holes for mounting the connector housings have been drilled. Follow the instructions in the chapter entitled **Mounting connector housings on side panels** (page 5-1).

- 1 Loosen the connector housing on the cabinet side panel by removing the four mounting screws securing it to the panel.
- 2 Insert the circuit card connector end (the end with a connector not equipped with a bracket) of the QPC414 Network Card or Superloop Network Card cables through the openings in the connector housing. Identification tags showing the assigned loop number should be placed on each of these cables.
- 3 Fasten the connector with a bracket to the connector housing with four # 6 sheet metal screws that are provided with the housing as shown in Figure 7-3.
- 4 If not previously installed, install the housing ground wire.

A length of # 6 AWG insulated ground wire, long enough to reach from the ground lug on the connector housing to the closest frame mounting rail inside the cabinet, is required for each connector housing. Note that the # 6 AWG wire is not supplied with the connector housing.

Route the ground wire from inside the connector housing, through the hole equipped with a grommet, and connect to the ground lug on the end of the housing as shown in Figure 7-3. Do not connect to the frame mounting rail inside the cabinet.

Connect one wire on each connector housing being installed.

- 5 From the inside of the connector housing, bundle the cables and the ground wire towards the center of the housing.

Feed the cables through the opening in the side panel of the cabinet.

Pull the cables through the opening until the connector housing rests against the cabinet.

—continued—

- 6 Secure the connector housing to **the** cabinet with the four mounting screws previously removed. Note that the end of the connector housing equipped with the ground lugs should be on the right when facing the side panel.
- 7 If not previously done, install a ground lug and connect the ground wire.

A ground lug and # 12 mounting screw are supplied with each connector housing.

Mount the ground lug with the screw to the closest point to the connector housing on the cabinet frame mounting rail.

Connect the ground wire from the housing to the ground lug. The ground wire must be kept as short as possible.

Repeat this step for each connector housing.
- 8 Route the network cables within the cabinet and connect them to their assigned shelves.
- 9 Connect an inter-cabinet network cable from the connector housing to its assigned connector on the module. One cable is required for each loop being installed.

Figure 7-3
Bracket and ground installation

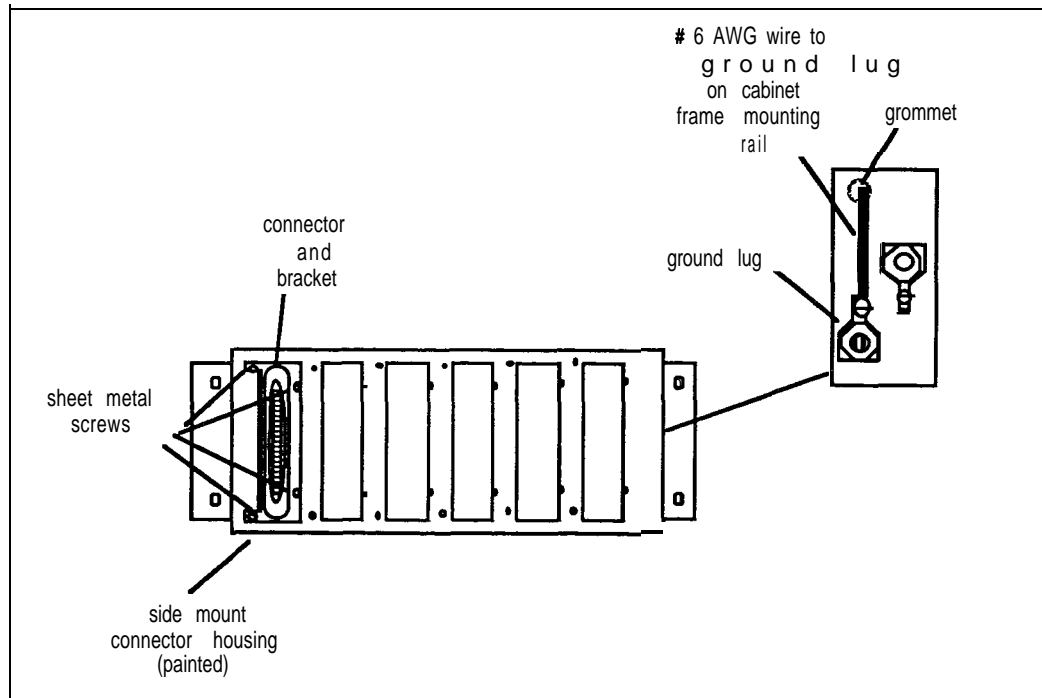

Connecting modules to ST-type cabinets

General information

This chapter describes how to connect modules to tiered cabinets such as the QCA136-, QCA137-, QCA141-, QCA147-, and QCA148-type and other similar type cabinets.

The types of cables required and their routing is shown in Figures 8-1 and 8-2.

Instructions for connecting modules to ST-type cabinets are given in **Procedure 8-1**.

8-2 Connecting modules to ST-type cabinets

Figure 8-1

Cable types and their routing (EMI suppression applications)

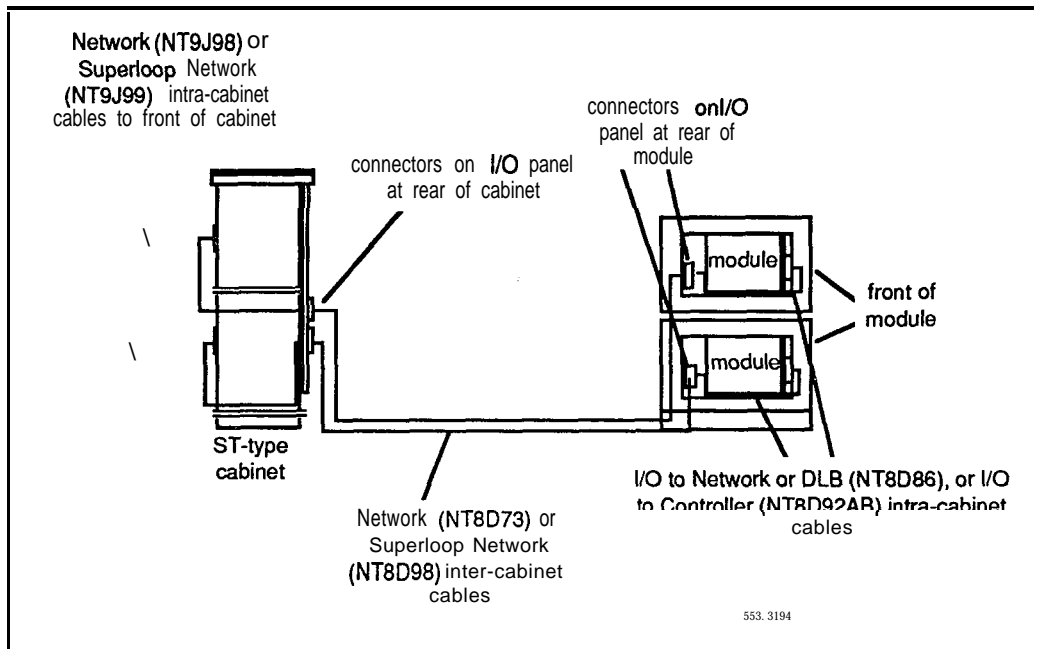
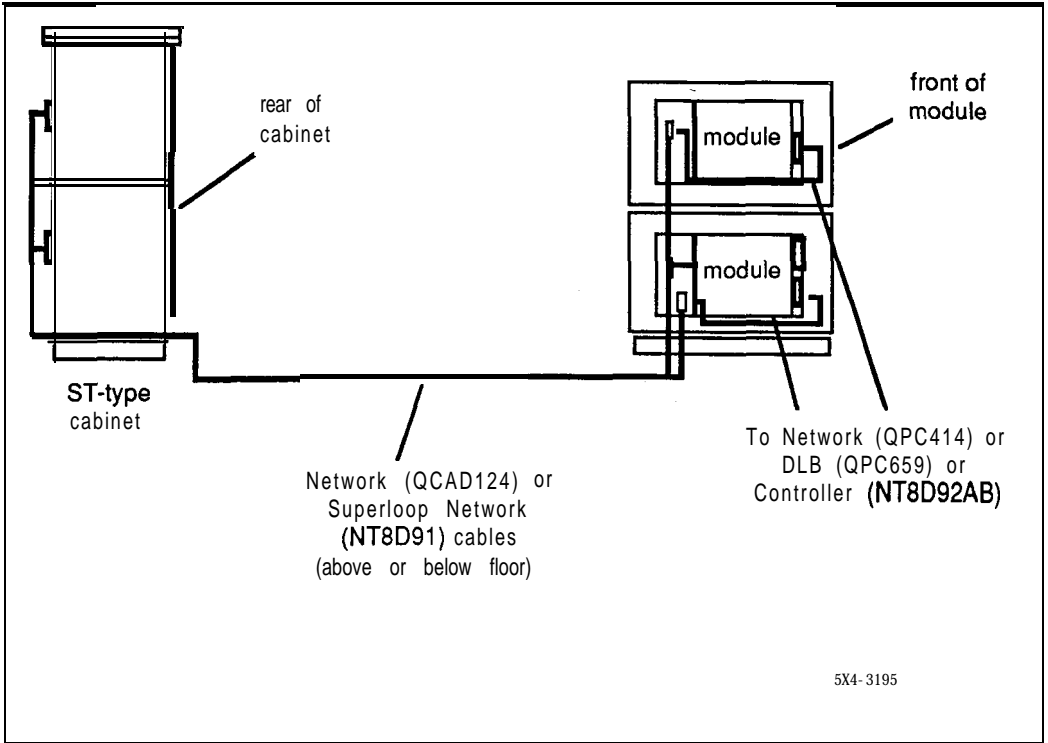

Figure 8-2
Cable types and their routing (non-EMI suppression applications)



Procedure 8-1
Connecting modules to ST-type cabinets

- 1** This step applies only if regulations concerning EMI apply to the existing cabinet.

Install the required number of cables for the network loops at the rear of the Meridian SL-1 ST-type cabinet. Installation instructions for these connectors can be found in the installation manual for the existing system.

- 2** This step applies only if regulations concerning EMI apply to the existing cabinet.

Connect one inter-cabinet cable from the connector at **the** rear of the existing cabinet to its assigned connector on the module. One cable is required for each loop being installed. Controller Card and Superloop Network Card connecting information is contained in **System installation procedures** (553-3001-210).

- 3** This step applies only if the existing cabinet is not subject to regulations concerning EMI.

Connect one cable between the QPC414 Network Card or Superloop Network Card and the DLB or Controller Card. Connection information is contained in **System installation procedures** (553-3001-210).

Connecting modules to QCA60 cabinets

General information

This chapter describes how to connect modules to QCA60 cabinets.

The types of cable required and their routing is shown in Figures 9-1 and 9-2.

Instructions for connecting modules to QCA60 cabinets are given in Procedure 9-1

Procedure 9-1

Connecting modules to QCA60 cabinets

- 1 Remove the front panels from the QCA60 cabinet. If the cabinet is not subject to EMI regulations and the cables are to be routed through the rear of the cabinet, remove the rear covers also. See Figures 9-1 and 9-2 for cable routing.
- 2 This step applies only if regulations concerning EMI apply to the existing cabinet.
 - Install a PO697559 mounting bracket to the upper inside lip of small lower front cover of the QCA60 cabinet as shown in Figure 9-1.
 - Remove the adaptor bracket from the connector on an NT9J96 cable. Reassemble the adaptor bracket and connector in the PO697559 mounting bracket on the inside cover of the cabinet. See Figure 9-3.

Connect the NT9J96 cable to its assigned network loop or shelf in the QCA60 cabinet.

- 3 This step **applies** only if regulations concerning EMI apply to the existing cabinet.

Connect one **NT8D73** cable from the connector on mounting **bracket** of the **QCA60** cabinet to its assigned connector-on the module for each loop being installed. See Figure 9-1.

Install the covers (including the new **PO697707** cover) on the front of the **QCA60** cabinet. See Figure 9-1.

- 4 This step **applies** only if the existing cabinet is not subject to regulations concerning **EMI**.

Connect one cable **between** the **QPC414** Network Card and the **DLB** Card.

Reinstall the covers on the **QCA60** cabinet.

Figure 9-1
Cable types and their routing (EMI suppression applications)

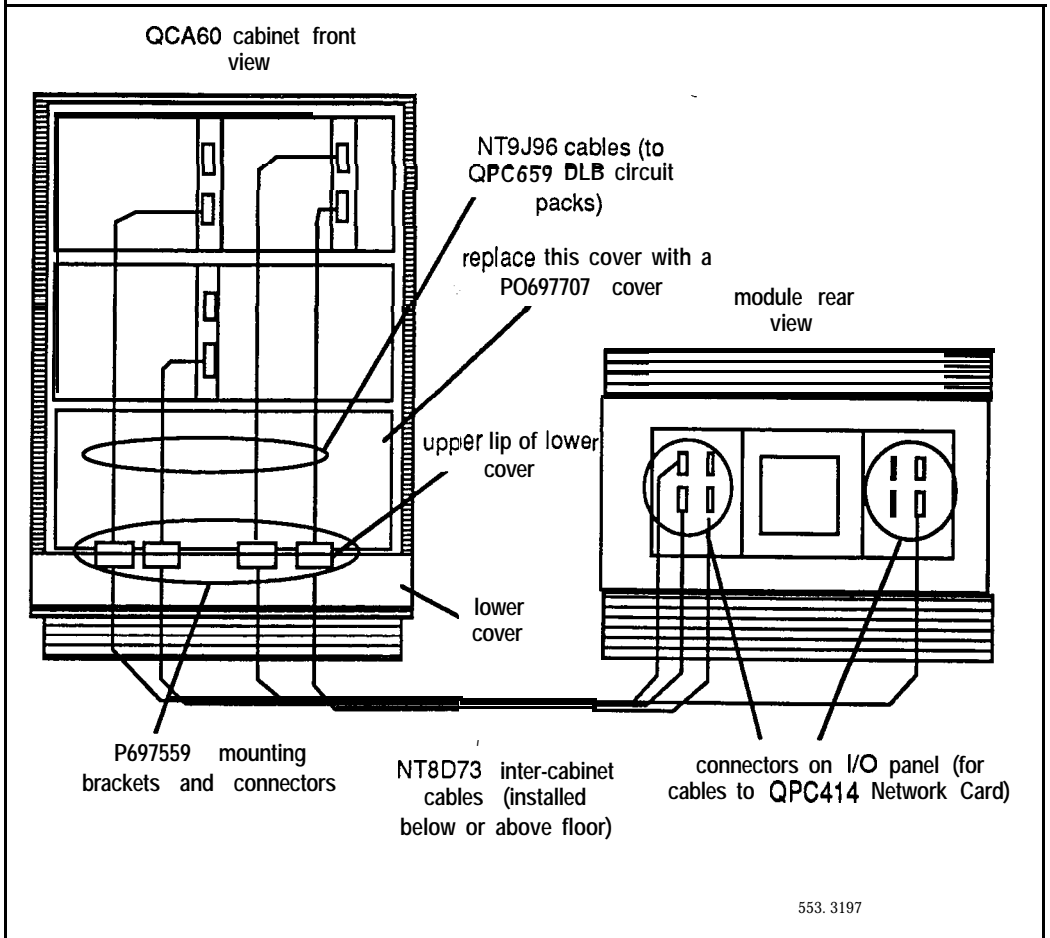

Figure 9-2
Cable types and their routing (non-EMI suppression applications)

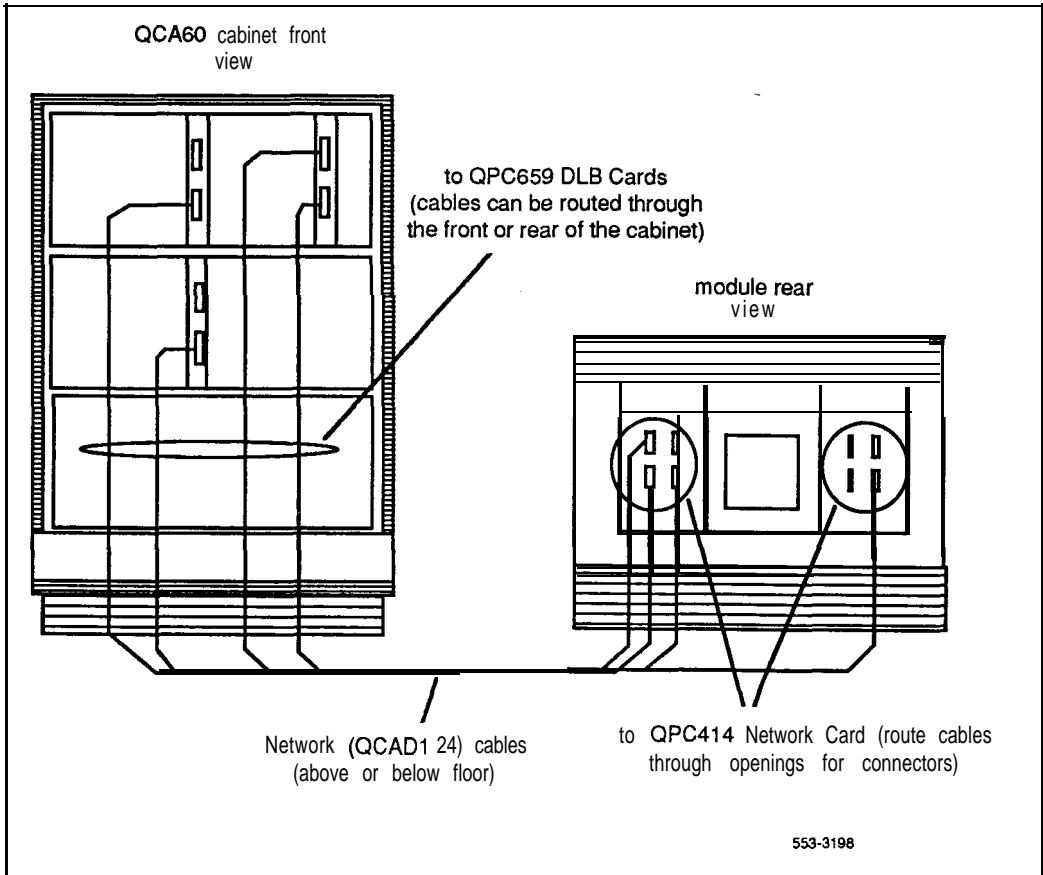
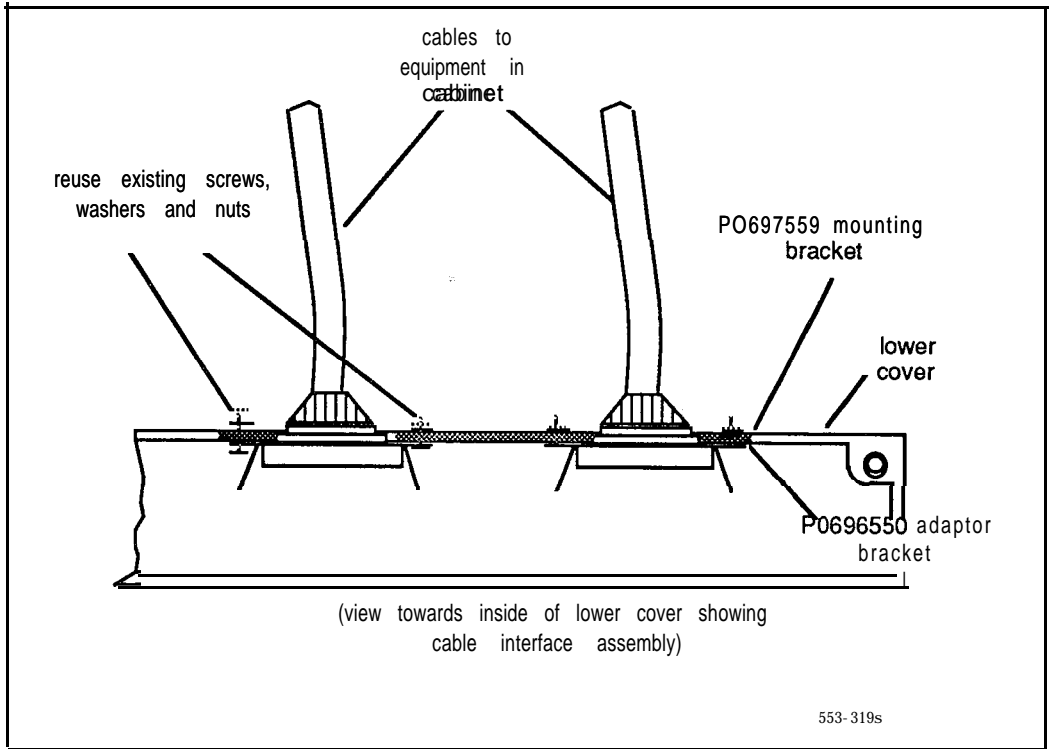

Figure 9-3
Mounting bracket (EMI suppression applications)





Configuring for Meridian 1 operation

General information

The following procedure describes the changes that must be made in software for Meridian 1 operation. See the XI1 *input/output guide* (553-3001-400) for information about loading overlay programs and about responses which apply to the prompts shown in this procedure.

Configuration procedure

- 1 Enter LD 17
 - Set the maximum PE density
At the prompt MPED, enter 8D
 - Assign the System Monitor device port
At the prompt ADAN, enter TTY
At the prompt USER, enter MTC
At the prompt XSM, enter YES
 - End the session in LD 17 with

- 2 EnterLD97
 - Define the IPE system parameters
 - Define the Controller Card numbers
 - Define the superloops
 - End the session in LD 97 with

- 3 Enter LD 32 and enable the superloops. Exit LD 32 with ****

- 4 Enter **LD** 30 and perform Network Signaling tests on all the loops.
Exit LD 30 with ****
- 5 Assign the telephones, consoles, trunks, and all other **equipment** assigned to the new system using the appropriate program as described in ***the X11 input/output guide*** (553-3001-400)





SL-1

System options 21, 51, 61, 71

Upgraded systems installation

Copyright © 1990 Northern Telecom

All rights reserved.

Information subject to change without notice.

Release 2.0

Standard

February 28, 1990

Printed in U.S.A.



553-3001-251

SL-1

System options ST, RT, NT, XT

Disk drive' upgrade procedures

Standard

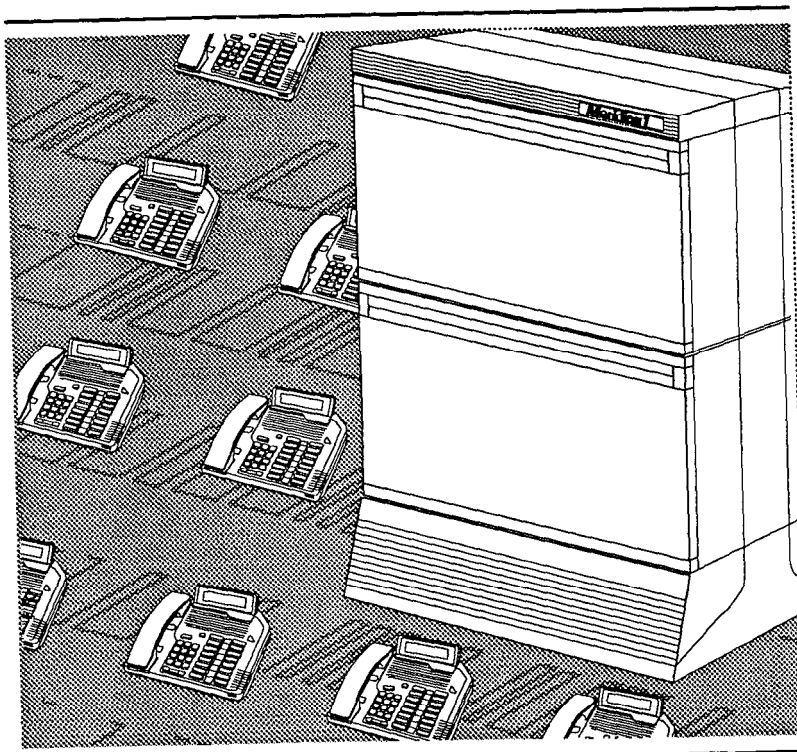

nt northern
telecom

Meridian 1
Communication Systems





SL-1

System options ST, RT, NT, XT

Disk drive upgrade procedures

Publication number: 553-3001-251
Document status: Standard
Document release: 2.0
Date: February 28, 1990



© 1990 Northern Telecom

All rights reserved.

Disk drive upgrade procedures 553-3001-251



ii

Revision history

January 29, 1990

Standard, release 1.0

February 28, 1990

Standard, release 2.0



Contents

General information	1
Equipment compatibility	1
FDU space requirements	1
MDU space requirements	1
FDI and MSI card slot positions	2
<hr/>	
Upgrade Procedures	3
RT, NT, and XT upgrades	3
Procedure 1 : QMM38 MSU and QPC584 MSI replacement	4
Procedure 2: QMM38 MSU and QPC584 MSI replacement	6
Procedure 3: Installing a Network expansion shelf	8
ST upgrades	9
Procedure 4: QMM43 floppy drive and QPC584 MSI replacement	9
Procedure 5: QMM45 floppy drive and QPC742 FDI replacement	11
Test Procedure	13
Procedure 6: Testing FDU, FDI or MDU, MSI	13



General information

This document provides detailed instructions for adding an **NT8D68** 3.5 inch Floppy Disk Unit (**FDU**) or an **NT8D69** 3.5 inch Multi Disk Unit (MDU) to an SL-1 system, and for upgrading the QPC584 Mass Storage Interface (MSI) or QPC742 Floppy Disk Interface (**FDI**) to meet XI 1 Release 15 data storage requirements.

Equipment compatibility

Table 1 provides disk drive, system, and card compatibility.

Table 1
Disk drive compatibility

Disk drive	System option	Card
NT8D68 FDU	ST, RT, NT, XT, 21, 51, 61, 71	QPC742D and later
NT8D69 MDU	RT, NT, XT, 51, 61, 71	QPC584E and later

FDU space requirements

The FDU occupies two adjacent card slots. Specific locations for each disk unit are dependent upon available space.

The FDU can be located in a Common Equipment (CE), Network (NET), **Intelligent** Peripheral Equipment (IPE) or existing Mass Storage Unit (MSU) shelf. The FDU receives its **power** from the QPC742 Floppy Disk Interfacc (FDI) card. **Shelf** backplane power is not necessary.

MDU space requirements

The MDU occupies **three adjacent** card slots. Specific locations for the disk unit is **dependent** upon available **space**.

The MDU can be located in a CE or NET shelf. Its location is limited only by the maximum cable length between **MSI** and MDU (18 feet maximum). If two MSI are equipped the cable length from both **MSI** to the MDU cannot exceed 18 feet.

If vacant space is not available within the cable **distance** requirements, relocate **PRI/DTI** and/or network cards to make **room** for the MDU. For NT and XT systems, the MDU may also be placed in an expansion NET shelf, equipped with a Power Converter card.

In NT systems, where no vacant positions are available to install the MDU, NET expansion shelves can replace PE shelves located on the rear of existing CE or MSU shelves. The existing MSU shelf may also be removed and replaced with a NET expansion shelf. Use Procedure 3 to install a NET expansion shelf.

In RT systems where no vacant positions are available for the MDU, a CE expansion tier must replace the PE tier located at the top of the main system cabinet. See **RT system installation procedures** (553-2441-210) for CE expansion tier installation procedures.

For XT systems where no vacant positions are available to install the MDU, additional NET shelves can be added to the CE cabinet. See XT **system installation procedures** (553-241 1-210).

FDI and MSI card slot positions

Table 2 provides disk drive and shelf slot location information for **MSI** and FDI cards.

Table 2
FDI/MSI card slot locations

Interface card	System	Card slot
QPC742 FDI	ST	3
or	RT	3 & 14
QPC584 MSI	NT	3 & 14
	XT	8

Upgrade Procedures

RT, NT, and XT upgrades

There are two possible disk drive upgrade options for RT, NT, and XT systems.

- Replace existing QMM38 MSU and QPC584 **MSI** with **NT8D68** FDU and **QPC742D** (or later) FDI (use Procedure 1).
- Replace existing QMM38 MSU and **QPC584** **MSI** with **NT8D69** MDU and **QPC584E** (or later) **MSI** (use Procedure 2).

Procedure 1: QMM38 MSU and QPC584 MSI replacement

Note: Use this upgrade procedure to replace QMM38 MSU and QPC584 MSI with NT8D68 FDU and QPC742D or later FDI in RT, NT, and XT systems.

- 1 Enter LD 43 from existing version of XI 1 software.
- 2 Remove existing **QPC584** MSI.
- 3 Make sure the new data cartridge is installed on each FDI **QPC742D** (and later) card. The ID number on the data cartridge should match the number on the disks provided with the software.
- 4 Set the **ENB/DIS** switch on each new FDI card to DIS.
- 5 Set option switches 1 and 5 on the FDI to ON, all other switches to OFF.
- 6 Insert the **NT8D68** FDU into its assigned position.

CAUTION

The **NT8D68** Floppy Disk Unit is powered from the **NT8D77** cable which connects to the **QPC742** FDI card. To prevent an electrical short which might disable the power converter, do not insert the FDI into its assigned position until after you have connected the **NT8D77** cable, at both ends.

- 7 Connect the FDU to each FDI using one **NT8D77** cable. This cable runs between one of the connectors on the FDU faceplate and the connector on the FDI faceplate.

Note: Connector 0 on the FDU is associated with CPU 0. Connector 1 is for CPU 1. In single CPU configurations connector 0 is recommended.

- 8 Insert each FDI into its assigned position (former position of the **QPC584** MSI).
- 9 Set the **ENB/DIS** switch on each FDI card to ENB.
- 10 Insert 3.5 in disks into the FDU. Be sure disk orientation is correct.

- 11 Perform a data dump using the EDD command.
- 12 Perform a sysload
- 13 Perform another data dump using the EDD command.
- 14 If the FDU is installed in an operating system, test it with Procedure 6.

Procedure 2: QMM38 MSU and QPC584 MSI replacement

Note 1: Use this procedure to replace QMM38 MSU and QPC584 MSI with NT8D69 MDU and QPC584E or later MSI in RT, NT, and XT systems.

Note 2: Perform steps 1 and 2 only if the system is not currently configured with a hard disk drive unit (QMT103).

- 1 Enter LD 17.
- 2 Change the configuration record to indicate that a hard disk is present at the prompt **IOTB** enter YES
at the prompt **ADAN** enter HDK 0
- 3 Exit overlay 17 and load overlay 43.
- 4 Remove existing QPC584 MSI.
- 5 Make sure the new data cartridge is installed on each MSI card (QPC584E or later). The ID number on the data cartridge should match the number on the disks provided with the software.
- 6 Set the ENB/DIS switch on each new MSI card to DIS.
- 7 Set option switches 1, 4, and 5 on each QPC584E MSI to ON, all other switches to OFF.
- 8 Insert the NT8D69 MDU into its assigned position.
- 9 Connect the MDU to each MSI using one NT8D80 cable. This cable runs between one of the connectors on the MDU faceplate and the connector labeled J1 on the MSI faceplate.

Note: Connector 0 on the FDU is associated with CPU 0. Connector 1 is for CPU 1. In single CPU configurations connector 0 is recommended.

- 10 Insert each new MSI into its assigned position.
- 11 Set the ENB/DIS switch on each MSI card to ENB.
- 12 Insert the 3.5 inch floppy disks into the disk drives of the MDU and copy contents to the hard disk using the RES command from LD 43.
- 13 Perform a data dump using the EDD command.

- 14 Perform a sysload.
- 15 Perform another data dump using the EDD command.
- 16 If the MDU is installed in an operating system, test it with Procedure 6.

Procedure 3: Installing a Network expansion shelf

Note 1: This procedure is used to install a Network expansion shelf (NET) in NT systems.

Note 2: The FDU does not take any power from the shelf backplane. If an FDU is installed in a shelf with PRI/DTI cards PRI/DTI installation rules apply.

- 1 Remove the existing QSD67/68 Disk Drive Shelf from the cabinet. Unplug power connectors and remove shelf mounting screws.
- 2 Unpack and inspect the NET expansion shelf.
- 3 Install the new shelf in the QSD67/68 shelf location.
- 4 Connect the power connector to the new shelf,

Note: The correct power connector may be tied back to the cabinet harness.

- 5 Install Power Converter card in assigned card slot, if MDU and/or PRI/DTI cards are being used in the shelf. See the table below.
- 6 Insert the NT8D68 FDU or NT8D69 MDU into assigned card slots. Insert PRI/DTI into assigned card slots.

Unit	QSD39 LH Shelf (card slot)	QSD40 RH Shelf (card slot)
QPC190/691 Power converter	1	14
NT8068 FDU	2-3	12-13
NT8D69 MDU	2-4	11-13
QPC720 PRI or QPC472 DTI	6-10	5-10

- 7 Connect and enable the PRI/DTI cards. See **Primary rate interface installation** (553-2901-200) and **Digital trunk interface installation** (553-281 1-200).
- 8 Continue with procedures 1 and 2 as appropriate.

ST upgrades

There are two possible disk drive unit upgrade options for ST systems:

- Replace existing QMM43 floppy drive and **QPC584 MSI** with **NT8D68** FDU and **QPC742D** (or later) **FDI** (use Procedure 4).
- Replace existing QMM45 floppy drive and QPC742 FDI with **NT8D68** FDU and **QPC742D** (or later) **FDI** (use Procedure 5).

Procedure 4: QMM43 floppy drive and QPC584 MSI replacement

Note: Use this procedure to replace QMM43 floppy drives and **QPC584 MSI** with **NT8D68** FDU and **QPC742D** or later **FDI** in ST systems

- 1 Enter **LD 43**.
- 2 Remove existing QMM43 disk drive unit and MSI.
- 3 Make sure the new data cartridge is installed in **each FDI QPC742D** (and later) card. The ID number on the data cartridge should match the number on the floppy disks provided with the software.
- 4 Set the **ENB/DIS** switch on each new **FDI** card to **DIS**.
- 5 Set option switches 1 and 5 on the **FDI** to **ON**, all other switches to **OFF**.
- 6 Insert the FDU into its assigned position.

CAUTION

The **NT8D68** Floppy Disk Unit is powered from the **NT8D77** cable which connects it to the **FDI** card. To prevent an electrical short which might disable the cabinet/shelf power, do not insert the **FDI** card into its assigned position until after you have connected the **NT8D77** cable at both ends.

- 7 Connect the FDU to each FDI using one **NT8D77** cable. This cable runs between one of the connectors on the FDU faceplate and the connector on the FDI faceplate.

Note: Connector 0 on the FDU and connector **J1** on **FDI** are recommended.

- 8 Insert each **FDI** into its assigned position (former position of the **QPC584** MSI).
- 9 Set the **ENB/DIS** switch on each FDI card to ENB.
- 10 Insert disks into the FDU.
- 11 Perform a data dump using the EDD command.
- 12 Perform a sysload.
- 13 Perform another data dump using the EDD command.
- 14 If the FDU is installed in an operating system, test it with Procedure 6.



Procedure 5: QMM45 floppy drive and QPC742 FDI replacement

Note: Use this procedure to replace QMM45 floppy drives and QPC742 FDI with NT8D68 FDU and QPC742D or later FDI in ST systems

- 1 Enter **LD 43**.
- 2 Remove existing QMM45 disk drive unit and QPC742 FDI.
- 3 Ensure the new data cartridge is installed in each FDI QPC742D (and later) card. The ID number on the data cartridge should match the number on the floppy disks provided with the software.
- 4 Set the **ENB/DIS** switch on each QPC742 FDI card to **DIS**.
- 5 Set option switches 1 and 5 on the QPC742 FDI to **ON**, all other switches to **OFF**.
- 6 Insert the FDU into its assigned position.
- 7 Connect the FDU to each FDI using one NT8D77 cable. This cable runs from a connectors on the FDU faceplate to a connector on the FDI faceplate.

Note: Connector 0 on FDU and connector J1 on FDI are recommended.

CAUTION

The NT8D68 FDU is powered from the NT8D77 cable. This cable connects FDU to the FDI card. To prevent an electrical short which might disable the cabinet/shelf power, do not insert the FDI card into its assigned position until after the NT8D77 cable is connected at both ends.

- 8 Insert each FDI into its assigned position.
- 9 Set the **ENB/DIS** switch on each FDI card to **ENB**,
- 10 Insert the 3.5 in disks into **the** FDU.
- 11 **Perform** a data dump using the **EDD** command.

- 12 Perform a sysload.
- 13 Perform another data dump using the **EDD** command.
- 14 If the **FDU** is installed in an operating system, test it using Procedure 6.



Test Procedure

In a working system use the following procedure to test the disk system.

Procedure 6: Testing FDU, FDI or MDU, MSI

- 1 Enter **LD 37**.
- 2 Make sure the disk unit and interface cards you are testing are not disabled:
STAT MSI
- 3 If the disk drive and interface cards are disabled, enable them:
ENL MSI 0
- 4 Test the disk drive unit:
MSI 0
 - If system response is other **than OK**, refer to X11 *input/output guide* (553-3001-400) to analyze the message(s).
 - If the error cannot be corrected, enter:
MSI RW 0
 - If response is **OK** the previous message can be ignored.
 - Exit Overlay 37:

Note: Perform steps 5 through 7 on dual CPU systems only.

- 5 Enter **LD 35**.
- 6 Switch CPUs, enter:
SCPU
- 7 Repeat steps 2 through 9 above.
- 8 If the disk drive or interface cards are faulty, replace them and perform the test again.

SL-1

System options ST, RT, NT, XT

Disk drive upgrade procedures

Copyright © 1990 Northern Telecom

All rights reserved.

Information subject to change without notice.

Release 2.0

Standard

February 28, 1990

Printed in U.S.A.

