

553-3001-100

SL-1

# System options 21, 51, 61, 71

System overview  
Standard

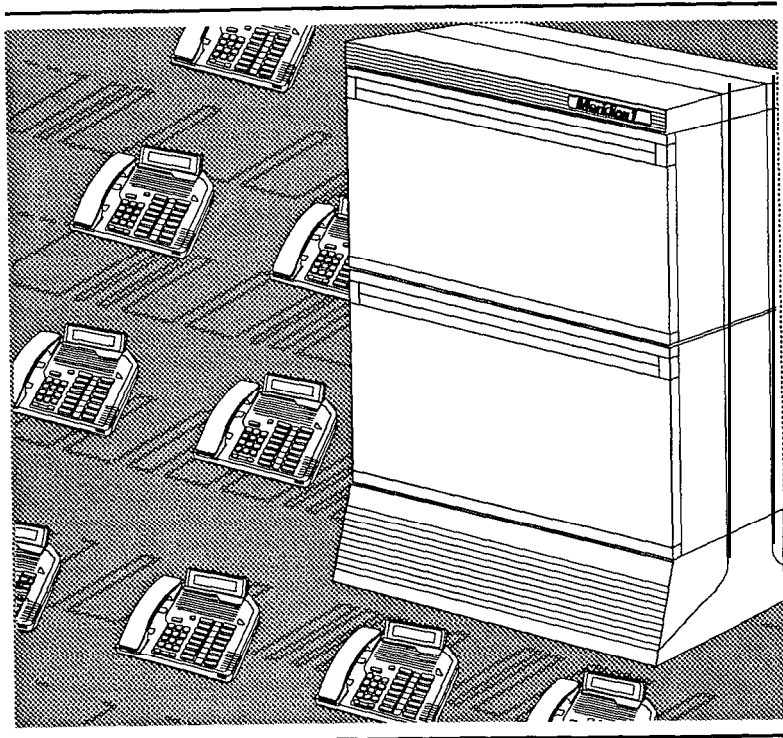

**nt** northern  
telecom

**Meridian 1**  
Communication Systems



---

SL-1

# **System options 21, 51, 61, 71**

## System overview

---

Publication number: 553-3001-I 00

Document release: 1 .0

Document status: Standard

Date: January 29, 1990

---



© 1990 Northern Telecom

All right reserved

---

System overview 553-3001-I 00

---

# Revision history

---

January **29, 1990**

Standard, release 1.0

---

## About this document

---

This document describes the features and services, hardware and software architecture, and the family of products that comprise Meridian 1.

### References

See *the SL-I planning & engineering guide* for

- **Master index** (553-3001-000)
- **System overview** (553-3001-100)
- **Installation planning** (553-3001-120)
- **System engineering** (553-3001-151)
- **Power engineering** (553-3001-152)
- **Sparesplanning** (553-3001-153)
- **Equipment identification and ordering** (553-3001-154)

See the list of line and trunk circuit descriptions in *the Master index* (553-3001-000) for specific references to lines and trunks.

See *the SL-1 installation and maintenance guide* for

- **System installation procedures** (553-3001-210)
- **Circuit pack installation and testing** (553-3001-211)
- **Installation procedures for telephone sets and attendant consoles** (553-3001-215)
- **Extended systems installation** (553-3001-250)
- **Disk drive upgrade procedures** (553-3001-251)

— **General maintenance information** (553-3001-500)

— **Fault clearing** (553-3001-510)

— **Hardware replacement** (553-3001-520)

**See the *SL-1 XII software guide*** for an overview of software architecture, procedures for software installation and management, and a detailed description of all XI 1 features and services. This information is contained in two documents:

— **XII software management** (553-3001-300)

— **XII features and services** (553-3001-305)

**See the *SL-1 XII input/output guide* (553-3001-400)** for a description of all administration programs, maintenance programs, and system messages.

---

# Contents

---

<b>Meridian 1</b>	<b>1</b>
The Meridian 1 commitment	2
Advanced features	5
<hr/>	
<b>System architecture</b>	<b>9</b>
Meridian 1 modular architecture	9
Control	9
Switching	9
Peripherals	10
Software architecture	10
Firmware	11
Software	11
Office Data	<b>11</b>
Resident Programs	11
Non-Resident Programs	11
Hardware architecture	13
Common equipment	13
Network equipment	17
Peripheral Equipment	31
Power equipment	32
<hr/>	
<b>Product description</b>	<b>37</b>
Universal Equipment Modules	37
CPU module (NT8D34)	39
CPU/Network module (NT6D39)	41
Network module (NT8D35)	43
Common/Peripheral Equipment module (NT8D11)	45
Intelligent Peripheral Equipment module (NT8D37)	48
Peripheral Equipment module (NT8D13)	50

---

Remote Peripheral Equipment Carrier module (NT8D47)	52
<b>InterGroup</b> module (NT8D36AA)	54
Meridian Mail module (NT6D44)	55
Pedestal (NT8D27AB)	57
Top cap (NT7D00)	57
Expansion kit (NT8D49)	57
Meridian 1 system options	60
Meridian 1 system option 21A	60
Meridian 1 system option 21	62
Meridian 1 system option 51	64
Meridian 1 System option 61	66
Meridian 1 system option 71	68

---

<b>List of terms</b>	<b>71</b>
----------------------	-----------

---

---

# Meridian 1

---

## Introduction

Meridian 1 Communication Systems are a family of digital multiplex voice and data switching systems built upon a foundation of state of the art digital switching equipment and advanced software program control. Meridian 1 systems provide a wide range of sophisticated voice and data services for both Private Branch Exchange (**PBX**) and Central Office (CO) applications ranging in size from 30 to 60,000 ports.

A Meridian 1 Communication System is a single source solution to the complex requirements of today's business communications environment. In a single, integrated system, it provides advanced voice features, local area network communications, and sophisticated information services. A comprehensive open architecture ensures continual growth in capacity and the capability to address the ongoing needs of business communications and information management.

The foundation for Meridian 1 Communication Systems is a voice and data circuit-switched digital sub-system. It is comprised of a central processing unit, memory store, and a digital switching network that uses time division multiplexing and pulse code modulation techniques. Peripheral interfaces are used to connect a wide array of telephones, trunks, and terminals.

Meridian 1 Communication Systems systems are also designed to accommodate the rapidly expanding requirements for data communications. Building upon the strength of the original SL-1 architecture, significant system enhancements have been developed for data communications, including:



Meridian Modular Telephones, a family of digital telephones that utilize standard twisted pair wiring and support a wide range of data communications options.

Meridian 1 LANSTAR, a 2.56 Mbps local area network (LAN) for Macintosh II and IBM PC compatible computers.

## The Meridian 1 commitment

Northern Telecom is committed to meet the needs of our customers by providing systems which guarantee:

Continuing product compatibility

A high degree of component and system reliability

Cost effective, modular packaging

Advanced administration and maintenance capabilities

Ease of installation

Cost effective system expansion and upgrade

## Product compatibility

All new products are compatible with the installed base of systems and can be installed alongside existing equipment. For network enhanced Meridian SL-1 systems, the upgrade consists of adding X11 release 15 software with a new CPU ROM pack, **Superloop** Network cards in existing network slots, and one or more Intelligent Peripheral Equipment Modules. For **non-network/CE** enhanced Meridian SL-1 systems, an upgrade package is also available. For more information about extending existing systems, see ***Extended systems installation*** (553-3001-250).

In addition, Meridian 1 systems now utilize the DS-30 signalling method used by other Northern Telecom switching products, providing a common signalling scheme throughout the Meridian 1 family and allowing for system growth beyond 10,000 ports without requiring a change in peripheral equipment.

## System reliability

Meridian 1 systems are designed and built to meet the highest standards for reliability, resulting in less downtime and increased system availability. In most systems, critical system elements are duplicated to guarantee system reliability. There are two identical Central Processing Unit (CPU) and memory circuits in most system configurations, and both CPUs can access both memory circuits. If one CPU or memory circuit fails, the system automatically switches to the standby CPU or memory circuit without disrupting call processing.

## Modular equipment packaging

Meridian 1 hardware is housed in modular equipment cabinets that are common to all system elements. These cabinets are called Universal Equipment Modules (UEM). Each UEM has removable front and rear covers with locking latches for easy access to its contents.

UEMs are stacked one on top of another to form a column. Each column may contain up to four UEMs. Systems are comprised of one or more columns. An Expansion Kit is provided to interconnect the columns in a multi-column system for compliance with FCC standards for EMI/RFI. At the base of each column of UEMs is the pedestal. The pedestal houses cooling fans, air filters, a power distribution assembly (including the circuit breakers and power switches) and a System Monitor circuit. At the top of each column is a Top Cap assembly which consists of two air exhaust grilles and a thermal sensor assembly.

## Advanced administration & maintenance

An important feature common to all Meridian 1 systems is an advanced administration and maintenance system. Administration and maintenance functions can be performed locally or at a remote location. These functions include service change, reassignment of features, and additions or deletions of equipment. Meridian 1 systems also provide an automatic in-line conversion feature which significantly simplifies upgrades of XI 1 software. Reconfiguration of system data structures occurs during system reload.

A System Monitor circuit card controls and monitors the status of all power-related hardware and functions, including column thermal status, power supply operation, blower operation, power fail transfer, circuit breakers, external rectifiers, batteries, and Uninterruptable Power Supply (UPS) systems. The same system monitor is used for AC and DC powered

systems. A System Monitor is installed **in the** pedestal of each column. The System Monitor located in the column containing **CPU0** acts as the master system monitor; monitors located in other columns act as slaves. The master polls the slaves and reports their status to the CPU. The master System Monitor is connected to the CPU by an **RS232C** port located on an **SDI** card. Slave System Monitors are connected to the master in a daisy chain fashion with an 8-conductor RJ type connector.

System messages reported to the CPU by the System Monitor are output to the system terminal. System messages include the following types of information: status or fault indication, hardware type, column number, module number and power supply unit number.

Maintenance and traffic messages are also output to the system terminal. Maintenance messages indicate the results of diagnostic routines and alert maintenance personnel to fault conditions. Traffic messages indicate the load on different areas of the system and the associated grade of service.,

Meridian 1 systems feature an advanced background diagnostic program which reports system status and identifies detected faults. The program automatically restarts where it stopped, following an interruption. Diagnostic routines may also be initiated by maintenance personnel as required.

A new series of circuit cards contain microprocessors which offload processing functions previously performed by the CPU. The on-board microprocessors significantly increase circuit card and system diagnostic capabilities, resulting in improved maintainability. Where possible, hardware switch selection has been replaced with software-controlled selection of circuit card options. The on-board microprocessors also allow for circuit card parameters to be changed without requiring hardware revisions. Parameters are stored on the system disk drive unit, and are downloaded to the circuit card at system reload or upon user command. The new cards also make use of on-board intelligence by reporting their product code, serial number, release number and manufacture location, assisting maintenance and inventory control.

## Ease of installation

Every Meridian 1 system is shipped from the factory assembled and equipped to order. Installation effort is reduced to unpacking and positioning equipment, plugging in connectorized cables, and adding customer-specific programming where required.

## Ease of expansion

The modular packaging scheme employed by the Meridian 1 family of products accommodates growth by permitting easy expansion. System expansion simply requires adding one or more **UEMs**. The modular packaging scheme also provides for low cost, easy expansion from one system type to another. For example, the card cage assembly of a UEM containing CPU equipment for a small system may be removed and replaced with the CPU card cage assembly designed for larger systems. In addition, peripheral equipment, which is the bulk of the system investment, is common to all system types and may be retained when **expanding**.

## Advanced features

By providing service capabilities defined by software, which can be expanded as needs evolve, Meridian 1 systems offer advanced features and capabilities in an economical, flexible, and maintainable form. In addition, to a wide range of standard voice and data services, Meridian 1 systems also provide a number of sophisticated communications services and features, including:

- Automatic Call Distribution (ACD)
- Electronic Switched Network (**ESN**)
- Call Detail Recording (CDR)
- Integrated Services Digital Network (**ISDN**)
- Meridian Mail Voice Messaging

## ACD

Automatic Call Distribution (ACD) is used when a large volume of incoming calls must be answered by a group of telephones allocated for this purpose. Incoming calls are served on a first-in, first-out basis and are distributed among the available telephones. For more information on ACD, refer to Northern Telecom Publication **Automatic Call Distribution Basic features description** (553-2671-100).

## ESN

The Electronic Switched Network (**ESN**) group of features supports voice and circuit-switched voiceband data telecommunications for multiple-location customer applications. ESN applications range from a single network node (combined PBX and network switching system) to a **widely-**dispersed network with up to 256 locations. For more information about ESN, refer to the ESN Feature Document **6400-886** and to the following Northern Telecom Publications:

- ESN: 308-3001-100
  - BARS/NARS: 553-2751-100, 553-2751-101**
- CDP: 553-2751-102

## CDR

Call Detail Recording (CDR) is a software package that gathers call processing data and produces call records used for accounting and administrative purposes. Call records provide information about the call, such as the time and **date** the call was placed, the identity of the caller, and the digits dialed. CDR is compatible with all Meridian 1 software generics. For more information, **see Call Detail Recording general description** (553-2631-100).

## ISDN

Integrated Services Digital Network (**ISDN**) is an international specification of standards for digital communications. ISDN provides standard digital interfaces between telephones, terminals, and telecommunication networks. ISDN services are distinguished by two types of access: Primary Rate Access (**PRA**) and Basic Rate Access (BRA). For more information on PRA, **see ISDN Primary Rate Access product description** (553-2901-100).

## Meridian Mail Voice Messaging

Meridian Mail is a comprehensive electronic voice processing system designed and developed to increase any organization's productivity by enhancing telecommunications activities. Meridian Mail provides a wide array of sophisticated features, including: telephone call answering, voice messaging, automated attendant service, call routing, information mailbox, and interactive voice response applications.

Meridian Mail voice messaging eliminates telephone tag and wasted calls by allowing detailed messages to be exchanged when parties are unavailable or busy. Guided by easy to follow prompts, a user can leave messages for others, retrieve messages, forward messages, and respond to messages with the touch of a single button.



---

# System architecture

---

## Meridian 1 modular architecture

An important characteristic of Meridian 1 systems is a modular system architecture. It utilizes an efficient and flexible approach, employing modular construction in all areas of hardware and software, and **state-of-the-art** commercial and custom components. The result is a system which is highly flexible in terms of operational, maintenance, and administrative characteristics. As demands dictate, any module may be enhanced, singularly or in combination with other modules. Each system is organized around three functional areas: Control, Switching, and Peripherals.

### Control

The Control complex provides the sequences required by the system to process voice and data call connections, monitor call activity, and perform system administration, maintenance, and testing. It is composed of two elements: the central processing unit (CPU) which directs lower level subsystems in the hierarchy, and the system memory which stores the operating programs.

### Switching

The switching function is performed by the network equipment, which interconnects terminal devices for communication with each other. The network architecture is based on the concept of a digital multiplexed loop. A loop is a bidirectional path between Network and terminal device which transmits voice, data and signalling information.



## Peripherals

Peripheral equipment provides the analog and digital interfaces for all peripheral devices, and performs analog to digital conversion of all input signals before switching is performed by the Network. Additionally, Peripheral equipment circuits provide the supervisory and transmission functions needed for trunks connected to the external telecommunications network.

Meridian 1 systems use a star topology for connecting peripheral devices to the switching equipment, an approach which permits uniform distributed wiring methods. This approach provides significant benefits in the area of administration, installation, maintenance and reliability.

Figure 1  
Meridian 1 modular architecture

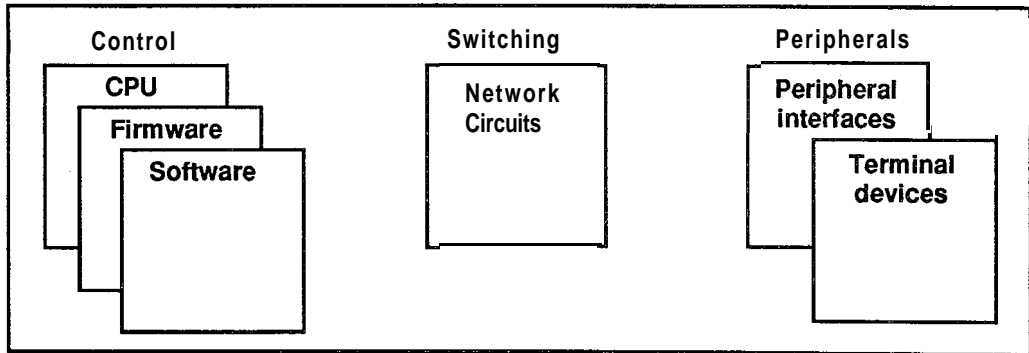

## Software architecture

The adaptability of software control provides a complete array of services and features tailored to meet changing requirements.

Call processing, maintenance and administration of Meridian 1 systems are controlled by software programs stored either as firmware programs, as software programs resident in system memory, or as non-resident programs on disk. The information which describes system configuration and associated peripheral equipment is termed office data. This data resides in the system memory and on disk.

## Firmware

These are fundamental programs consisting of hard-wired logic instructions stored in Programmable Read Only Memory (PROM) which manipulate data in the central processor and control input/output operations, error diagnostic and recovery routines.

## Software

Software programs consist of instruction sequences that control call processing, peripheral equipment, administration and maintenance functions. These sequences are interpreted by the firmware programs into machine instructions. Several generic software programs with optional feature packages are available to satisfy varying requirements.

## Office Data

The office data describes the characteristics of the system in terms of configuration and call dependent information such as features and services. Office data is arranged into blocks defining peripheral equipment, system configuration and transient data. These data blocks permit configuration of Meridian 1 systems to specific customer needs.

## Resident Programs

Resident Programs are programs always available in memory during system operation. Firmware programs control other resident programs and provide all CPU arithmetic operations. The other resident programs are those which are automatically loaded into the system memory **from** the disk drive at system power-up. Once loaded, these programs remain in memory.

## Non-Resident Programs

Non-Resident Programs are the overlay programs stored on disk which are loaded into the "overlay area" of system memory when required to perform specific tasks. Only one overlay program may be loaded at a time and is removed from the overlay area when no longer required. Overlay programs can be loaded automatically, under program control, or manually, via an administrative terminal.

Once the user has logged into the system, commands for specific overlay programs are processed by the overlay loader program. When loaded, the overlay program assumes control. Only one administrative terminal can input into the overlay **area** at a time. More than one device, however, can

receive output simultaneously. A terminal may be configured as an input only or output only device.

Overlay programs provide the system interface for maintenance, service change, and traffic measurement. Each overlay program is independent and has its own specific set of commands and formats. Overlay programs may be run concurrently with normal call processing without interfering with system traffic. There are five main categories of overlay programs:

### **Service Change and Print Routines**

Service changes do not generally require hardware intervention. Instead, the service administration programs are used to create or modify all aspects of the system from individual feature key assignments to complete system configurations. There are also programs and print routines for retrieving the data from the system to check the status of office data assignments.

### **Maintenance Diagnostics**

These programs are the primary instruments for maintenance purposes. Individual programs are used for automatically or manually testing the CE and PE. The programs may be loaded into the overlay area at the request of maintenance personnel, or as part of a daily maintenance routine automatically initiated by the system at a specified time. In addition, background and signaling diagnostic routines can occupy the overlay area when it is not in use.

### **Traffic**

All systems are equipped with traffic data accumulation programs. There is also a resident traffic print program which examines the schedules, transfers data from accumulating to holding registers in accordance with schedules, and prints the traffic data. In addition, there is a traffic overlay program which is used to query and modify schedules, options, and thresholds.

### **Equipment Data Dump**

After making service changes, the changes must be transferred to disk in order to save them. When the equipment data dump program is invoked, all the office data in the read/write memory is written to the system disk. The data dump program is also used to install a new generic version or issue and capture protected data store information which may be changed by the user, such as speed call lists. The program may be invoked automatically during

a midnight routine or on a conditional basis (i. e. , data dump only occurs if a software service change has been made). It may also be invoked manually via the input/output (I/O) interface to the system.

### Software Audit

This program monitors system operation and gives an indication of the general state of the system operation. The program is concerned mainly with **the** system software. When a software problem is encountered, the program attempts to clear the problem automatically.

## Hardware architecture

Each Meridian 1 system is composed of the following hardware subsystems:

- Common equipment (CE): Provides the device control, software execution, and memory functions of the system.
- Network equipment (NET): Performs the switching function under CPU control.
- Peripheral equipment (PE): Provides the interface for line and trunk circuits.
- Terminal equipment: Telephone sets and attendant consoles.
- Power equipment Provides the electrical voltages required to operate equipment.

### Common equipment

Common Equipment (CE) consists of one or more Central Processing Units (CPUs), memory circuits, and mass storage devices which control the operation of **the** system. The CE communicates over a common control bus which carries a constant flow of program instructions and data under direct control of the CPU. The digitized speech signals follow a separate path on a network switching bus which allows communications links to be established between any of the peripheral devices.

- The Central Processing Unit (CPU) provides the computing power essential for entire system operation.

- The system memory stores all operating software programs and data unique to the particular Meridian 1 system, including switching sequences, features, class of service information, and quantity and types of terminals.
- The Mass Storage Unit provides high speed loading of the operating programs and data into memory.
- The Digital Service Circuits provide functions such as dial and ringing tones, and call conferencing capabilities.
- The Serial Data Interface (SDI) provides a **RS232C** communications link for administration and maintenance on either a local or remote basis.
- The Network Circuit Cards provide a digital matrix for circuit-switched connections to associated peripheral devices.

### Central Processing Unit (CPU)

The CPU performs the control and switching sequences required by the system. The software **that** directs these functions is loaded into the system memory from the mass storage unit by the CPU. Information flows between the CPU, I/O devices, and the system memory over the CPU bus.

The data required by the CPU to perform its control and switching functions is held during system operation in Random Access Memory (RAM) and fed to the CPU via the CPU bus. The operating data is loaded into the RAM from floppy diskettes on system power-up.

The CPU function is performed by circuit cards which include **Read-Only-Memory** firmware that contains fault clearing programs and instructions to control the loading of system memory from the mass storage unit.

Meridian 1 systems incorporate a CPU design that is identical for most system options.

- 24-bit data words plus 1-bit parity
- 24-bit linear addressing that permits memory allocation to be assigned on a contiguous basis instead of the 64K pages partitioning referenced above
- 16M words • subdivided for up to 12M words of physical memory space and a remainder of 4M words for I/O spaces

- asynchronous (handshake) bus operation
- 16 file registers used to hold address and data for all operations
- a sense (interrupt) input line to indicate that a particular device (tape, **TTY**, PE) requires action by the CPU
- a trap facility which, when activated by an external signal, causes the CPU to immediately begin executing instructions starting at a particular address; this facility is used to enter a recovery routine when a fault is detected

### **Mass Storage Unit**

A mass storage unit equipped with two floppy diskettes and/or a Winchester hard disk is used for high speed loading of the resident operating programs and office data into system memory. The loading process is controlled by instructions held in the Read-Only-Memory (ROM) firmware. When loading is complete, the diskettes remain in the mass storage unit to provide a non-volatile store for automatic loading purposes in the event of software being erased from memory during a power failure. Non-resident software is loaded from the disk automatically or by manual request when required.

The Mass Storage Interface (MSI) card is designed to interface with external devices that are compatible with the Small Computer System Interface (SCSI). This storage capability is provided by the following hardware configurations:

- NT8D68AA Floppy Disk Unit: two 3.5" 1.2 Mbyte floppy disk drives (providing 2.4 Mbytes of formatted capacity) as a standard system offering,
- NT8D69 AA Multi Disk Unit: a Winchester Hard Disk with 10 Mbytes of formatted capacity. When this option is equipped, the floppy disks are used for backup and system loading.

Both types of Mass Storage Unit (**MSU**) are compatible with any Meridian 1 system running Software Generic XI 1 Release 8 or later. The upgrade procedure involves replacing the Magnetic Tape Transport and associated tape interface with the desired Mass Storage Unit and equivalent Mass Storage Interface card (**MSI**) or Floppy Disk Interface (**FDI**) card. The Mass Storage Unit requires the identical space required for the magnetic **tape** unit. See *Disk drive* upgrade procedures (553-3001-251) for more information about disk drive upgrades.

### **Input / Output (I/O) Interfaces**

There are various methods of communicating with Meridian 1 systems. A family of Serial Data Interface (**SDI**) circuit cards provides from one to four communication channels which conform to EIA Data Interchange Standard RS-232-C. I/O addressing is under switch control of the **SDI** card and allows up to 16 RS-232-C compatible devices, such as a terminals, to communicate with the system. The devices are used to input commands and/or receive responses from the system during administration and maintenance procedures.

### **Memory**

Firmware, software, and data are stored in a read/write Random Access Memory (**RAM**). The memory is a critical part of the stored program control system. It contains the memory stores of all of the basic operating instructions for the system, plus data on the configuration of the particular application being served. Memory utilization is dependent upon what features are programmed into the system and the number of peripheral terminations being served. The memory is split into four segments to facilitate processor address purposes and permit a functional separation of programs.

- Unprotected Data Store (**UDS**): These pages hold the transient or unprotected data that is required during call processing. Included are the timing queues and call registers.
- Protected Data Store (**PDS**): This protected data store holds the office data blocks that are particular to specific installations.
- Program Store (**PS**): Allocations within the Program Store are as follows:

- **Firmware** — This portion of the memory is a non-volatile Read Only Memory (ROM) used for storage of all system firmware. The ROM is programmed during manufacture and the instructions are permanent and indestructible. It stores the basic rules of operation necessary to initialize the system and bring it into a working state. A recovery or “trap sequence” is included in firmware which is automatically invoked in response to power-on, system reset, or when certain faults are detected.
- **Overlay** — This portion of the memory may be loaded with various non-resident programs as required during automatic diagnostics, service order change, traffic measurement, or maintenance.
- **Software** — The remainder of this memory page is reserved for all of the system software such as the call processing and optional programs. Additional software storage capability is provided by the incremental addition of more memory pages within this category.
- **Input / Output Addresses** — There are no RAM modules utilized for this page. Instead the address range is reserved for Input/Output (I/O) device addresses. These devices include signaling for peripheral equipment along with magnetic tape and terminal assignments.

## Network equipment

Network equipment consists of network circuit cards which perform the digital switching of voice and data signals, peripheral signalling cards which perform scanning and signal distribution, and service circuit cards, such as tone and digit switches, which provide call progress tones and outpulsing as instructed by the CPU. Network circuits employ Pulse Code Modulation (PCM) and Time Division Multiplexing (TDM) to perform the switching function.

### Loops and Superloops

Network equipment interfaces with peripheral equipment via digital multiplexed loops. A loop is a bidirectional path between Network equipment (NET) and Peripheral equipment (PE) for voice, data and signalling information. Upon commands from the CE, the network establishes a path, linking a specific input to a specific output.



Meridian 1 systems provide two network circuit cards, the QPC414 Network Card which provides 2 loops per card, and the **NT8D04AA** Superloop Network Card which provides 4 loops per card, grouped together in an entity called a Superloop. The Superloop permits all 120 timeslots provided by the network card to be shared among the peripheral devices served by the superloop, providing higher traffic capacity and simplified traffic engineering.

The flexibility of the network loop plays an important role in the Meridian 1 architecture. Besides the ability to increase circuit-switched bandwidth on an incremental card basis for cost-effective growth, application may be varied for value added services. The network structure allows for the full connectivity of all devices irrespective of how they connect to the system.

The network loop is a key element in the implementation of Computer to PBX Interface (CPI) and Digital Trunk Interface (DTI). CPI provides an integrated interface for connecting large numbers of host computer ports via 24 channels each supporting up to 19.2 kbps for asynchronous data or up to 56 kbps for synchronous data. DTI provides a digital link of 24 channels each of which may be flexibly allocated for **both** voice and data communications. Both CPI and DTI use the North American T-1 standard (DS-1 format) and each equipped link is assigned an associated network loop.

### **Network organization**

Network loops are organized into groups. Systems are configured as half, full, or multiple group machines. A half network group machine provides a up to 16 loops, a full group system provides from 17 to 32 loops, while a multiple group system provides from 33 to 160 loops.

For applications beyond the traffic handling capability of the single network group, additional switching stages are introduced to form a multi-group arrangement. These connecting paths, provided by the **InterGroup** Module, are merely an extension of the originating and terminating network loop involved in a call. There are eight one way junctors from each group to all others. Since each path provides thirty connecting channels, a total of 480 connection paths exist from one group to another - 240 in each direction. Five network groups may be interconnected to constitute a fully configured digital switching matrix.

### **Network/Peripheral configuration**

The allocation of peripheral equipment to the network loop determines the traffic handling capability of the switching network. The lower the number of terminations, the higher the loop traffic capacity. The quantity and type of terminal assignments are allocated to optimize the traffic handling capabilities of the switching network.

A universal PE bus structure permits any mix of **PE** card types to be located in a PE module. Provisioning of PE cards and their associated density (number of ports) determines the network loop to PE module configuration. Complete modularity permits voice and data modules to be segregated so that the specific traffic patterns of one may be met without impeding the other.

### **Enhanced Network Configurations**

For peripheral equipment housed in **NT8D13** PE modules, network capacity may be allocated in single loop mode and dual loop mode. In single-loop mode, one peripheral equipment module is connected to one network loop, yielding a maximum concentration of 160 terminations to 30 time slots. In dual loop mode, half of the PE cards in a module use one loop, and the other half use another loop, yielding two maximum concentrations of 80 terminations to 30 time slots.

**Figure 2**  
**Single and dual loop configurations**

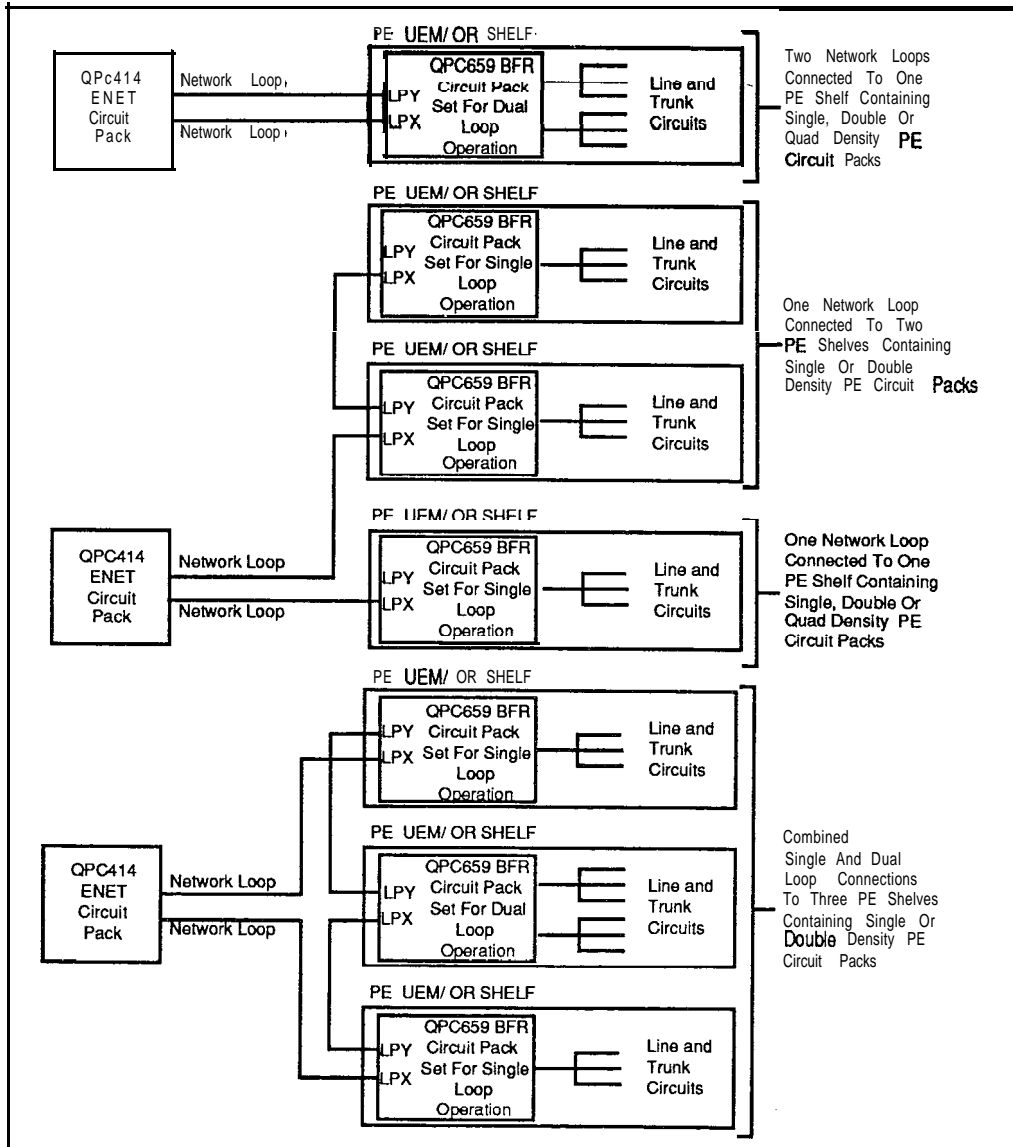

### Superloop Network Configurations

The Superloop Network Card combines four regular network loops to make 120 timeslots available to PE cards housed in Intelligent Peripheral Equipment Modules. **This** increased **bandwidth** and **larger** pool of timeslots increases **the** network traffic capacity by 25% for each 120 **timeslot** bundle. The **NT8D37** Intelligent PE Module is divided into segments of 4 card slots. These segments are numbered 0-3. Segment 0 consists of PE slots 0-3, segment 1 consists of card slots 4-7, segment 2 consists of card slots 8-11, and segment 3 consists of card slots 12-15.

A Superloop may be assigned from one to eight Intelligent PE segments. A number of different superloop to segment configurations are possible. The configuration chosen will depend upon system traffic requirements and the specific PE cards used. Figures 4 through 9 illustrate different superloop to segment configurations. Note that the TN to **Timeslot** concentration figures (figure 3) are nominal, and may vary from segment to segment.

**Figure 3**  
**NT8D37 Intelligent Peripheral Module segmentation**

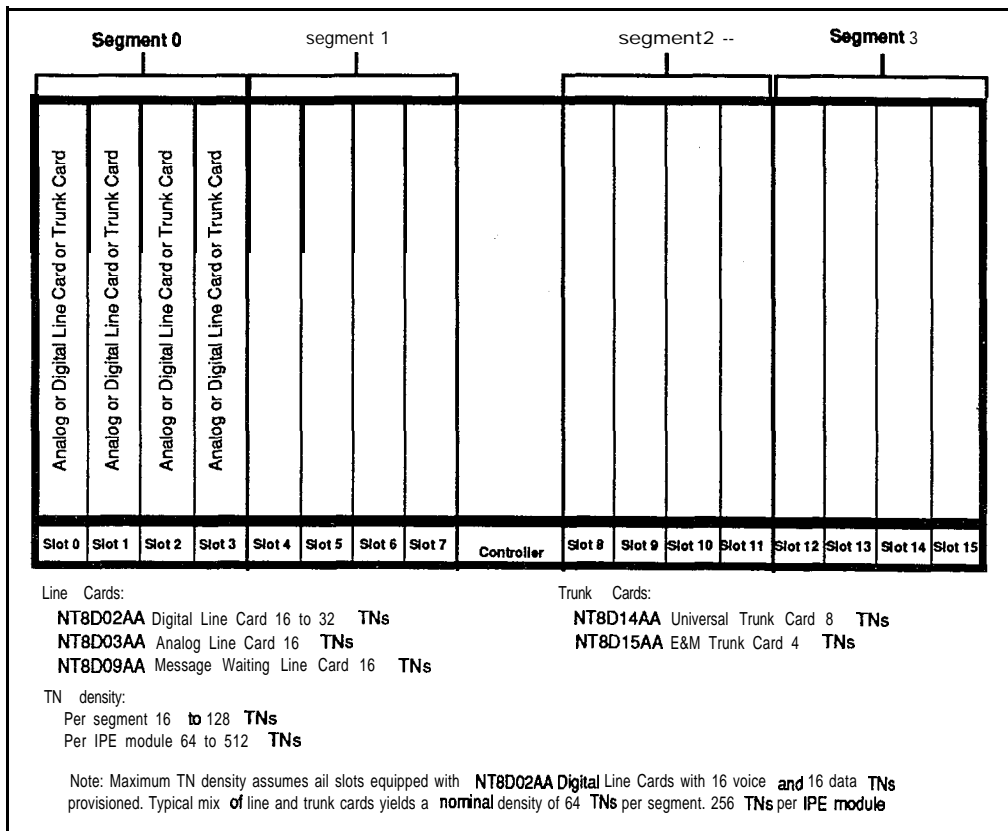

### 1 segment per Superloop

In this configuration, 1 segment is assigned to 1 Superloop (see Figure 4). In cases where the segment is populated with NT8D02AA Digital Line Cards with all 16 voice and all 16 data TNs provisioned, the 1 segment per superloop configuration will provide a virtual non-blocking (120 Timeslots to 128 TNs) environment (see Figure 2) Four NT8D04AA Superloop Network Cards and one NT8D01AC Controller-4 Card are used to implement a 1 segment per superloop configuration.

Figure 4  
1 segment per Superloop configuration

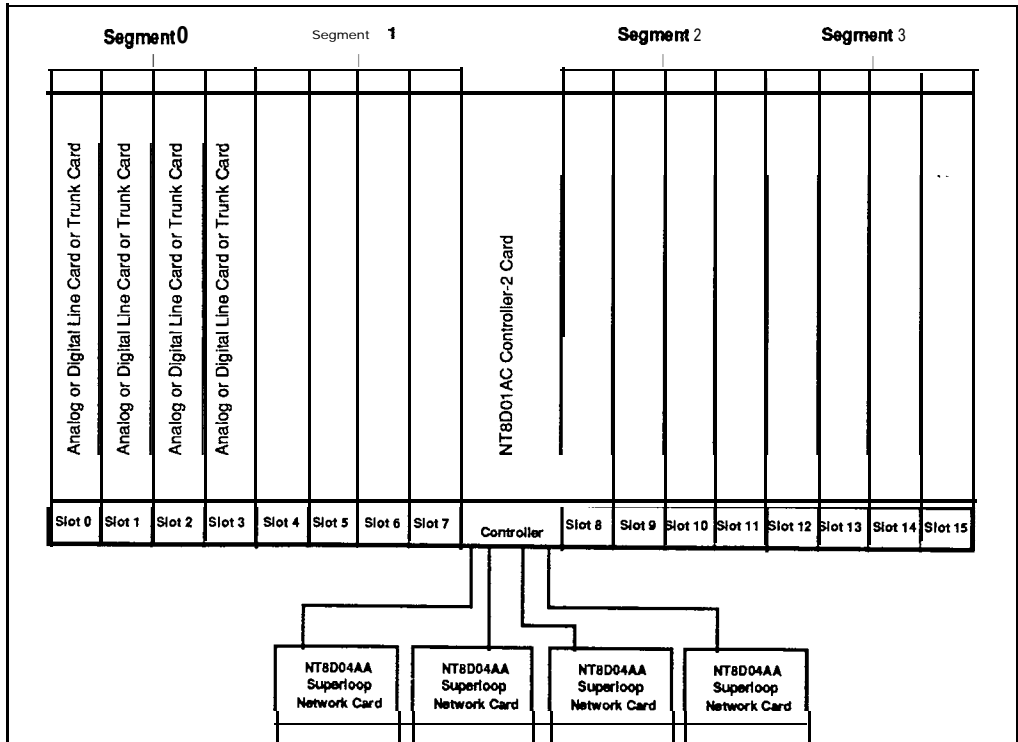

### 2 segments per Superloop

In this configuration, 2 segments are assigned to 1 Superloop (see Figure 5). In cases where the segment is populated with NT8D02AA Digital Line Cards with no data TNs enabled, NT8D03 Analog Line Cards, NT8D09AA Message Waiting Line Cards, or NT8D14AA or NT8D15AA Tnmk Cards, the 2 segment per superloop configuration will provide a virtual non-blocking (120 Timeslots to 32-128 TNs) environment (see Figure 2). For instances where half of the data TNs on NT8D02AA Digital Line Cards are enabled, this configuration still provides a low concentration of TNs to timeslots (120 Timeslots to 1% TNs) and a very low probability of blocking. Two NT8D04AA Superloop Network Cards and one NT8D01AD Controller-2 Card are used to implement a 4 segment per superloop configuration.

**Figure 5**  
2 segments per Superloop configuration

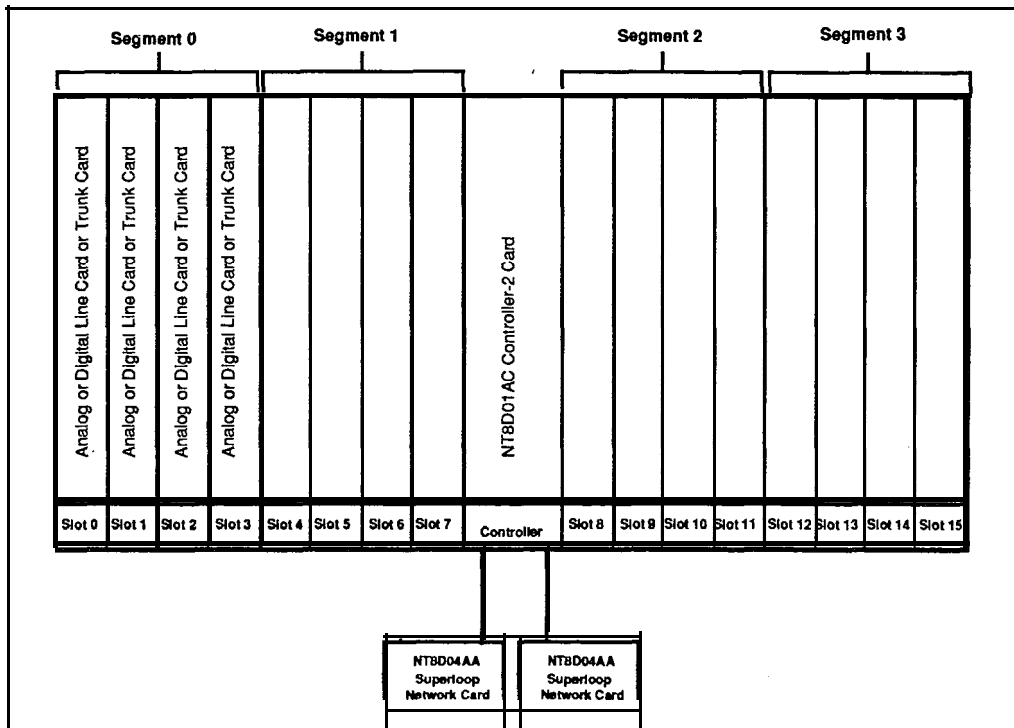

### 4 segments per Superloop

In this configuration, 4 segments are assigned to 1 Superloop (see Figure 6). In cases where the segment is populated with **NT8D02AA** Digital Line Cards, **NT8D03** Analog Line Cards, **NT8D09AA** Message Waiting Line Cards, or **NT8D14AA** or **NT8D15AA** Trunk Cards, the 4 segment per superloop configuration will provide a medium concentration (120 Timeslots to 64-256 **TNs**) environment (see Figure 2). In instances where half of the data **TNs** on **NT8D02AA** Digital Line Cards are enabled, this configuration provides a concentration of 120 Timeslots to 384 **TNs**. One **NT8D04AA** Superloop Network Card and one **NT8D01AD** Controller-2 Card are used to implement a 4 segment per superloop configuration.

Figure 6  
4 segments per Superloop configuration

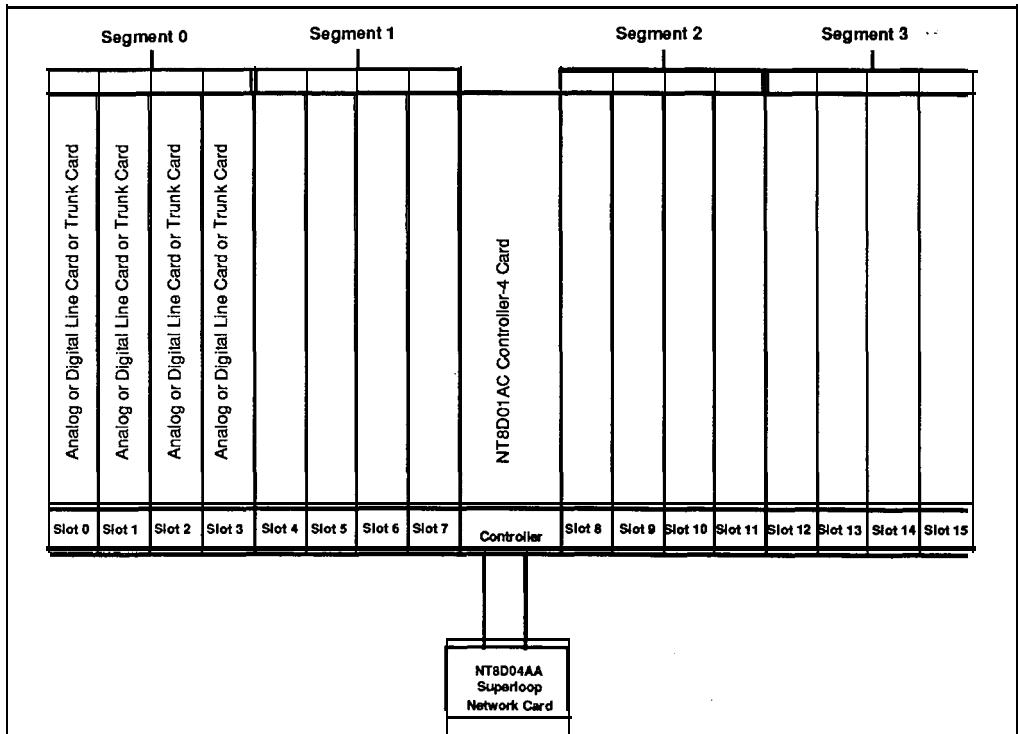



### **8 segments per Superloop**

In this configuration, 8 segments are assigned to 1 Superloop (see Figure 7). In cases where the segment is populated with **NT8D02AA** Digital Line Cards, **NT8D03** Analog Line Cards, **NT8D09AA** Message Waiting Line Cards, or **NT8D14AA** or **NT8D15AA** Trunk Cards, the 8 segment per **superloop** configuration will provide a high concentration (120 **Timeslots** to 128-512 **TNs**) environment (see Figure 2). In instances where half of the data **TNs** on **NT8D02AA** Digital Line Cards are enabled, this configuration provides a concentration of 120 **Timeslots** to 768 **TNs**. One **NT8D04AA** Superloop Network Card and two **NT8D01AD** Controller-2 Cards are used to implement an 8 segment per superloop configuration.

**Figure 7**  
8 segments per Superloop configuration

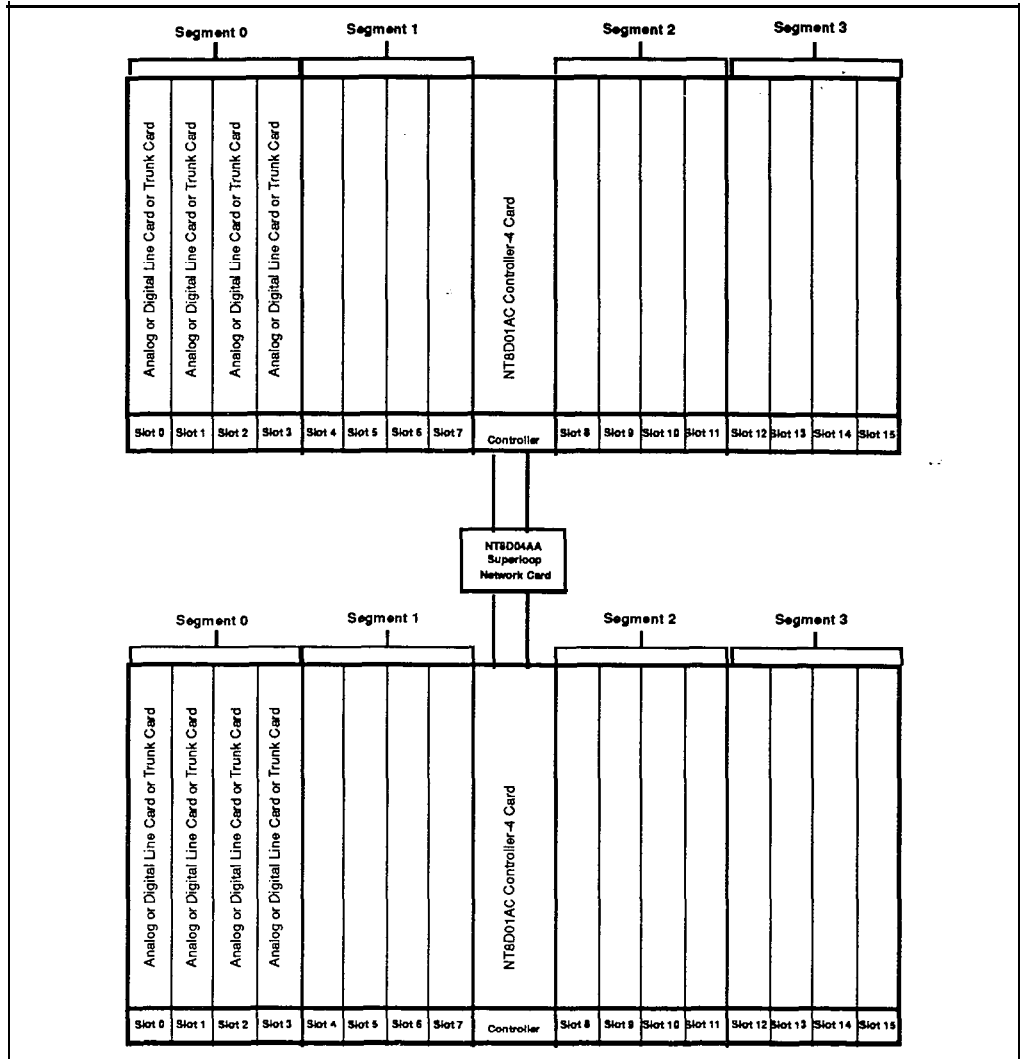

**1 segment per Superloop/3 segments per Superloop**

In this configuration, 1 segment is assigned to 1 Superloop and an additional 3 segments are assigned to another Superloop (see Figure 8). This configuration provides a virtual non blocking environment for the single segment served by the **first** Superloop and a medium concentration of **TNs** to Timeslots for the 3 segments assigned to the additional Superloop, as described in the preceding examples. Two **NT8D04AA** Superloop Network Cards and one **NT8D01AD** Controller-2 Card are used to implement a 1 segment and 3 segment per superloop configuration.

**Figure 8**  
**1 segment per Superloop/3 segments per Superloop configuration**

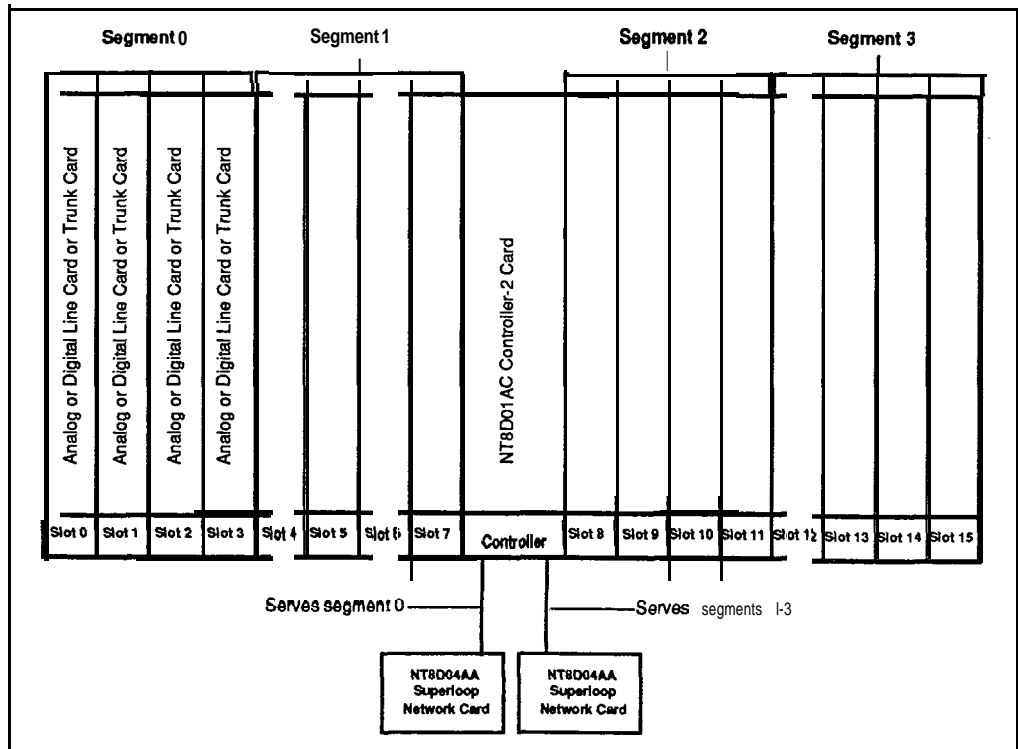

## 2 segments per Superloop/6 segments per Superloop

In this configuration, 2 segments are assigned to 1 Superloop and an additional 6 segments are assigned to another Superloop (see Figure 9). This configuration provides a virtual non blocking environment for the two segments served by the first Superloop (or a very low concentration of **TNs** to Timeslots when some data **TNs** are enabled) and a medium concentration of **TNs** to Timeslots for the 3 segments assigned to the additional superloop, as described in the preceding examples. Two **NT8D04AA** Superloop Network Cards and two **NT8D01AD** Controller-2 Card are used to implement a 2 segment and 3 segment per superloop configuration.

**Figure 9**  
 2 segments per Superloop/6 segments per Superloop configuration

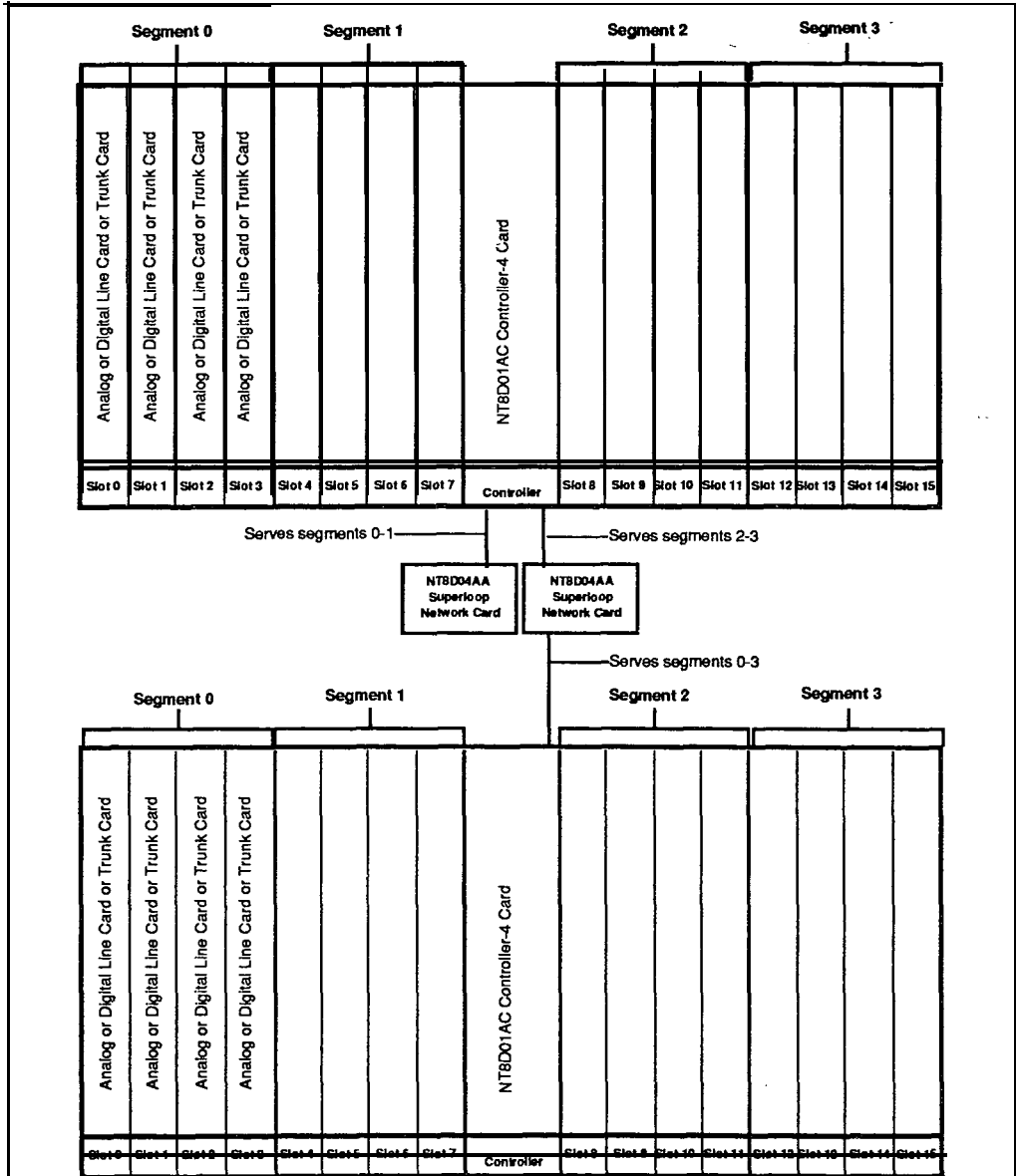

## Peripheral Equipment

Peripheral Equipment consists of peripheral controller cards which provide the timing and control sequences for peripheral circuits, analog and digital line and trunk cards, which provide the interfaces for terminal devices, and circuit cards which provide Digital Trunk Interface (**DTI**) and Primary Rate Access (**PRA**) services.

The peripheral controller performs the first stage of multiplexing signals from the terminals, which are then passed on to the network for digital switching. The peripheral controller also transmits timing signals, and carries out other functions associated with the control of the peripheral circuits.

The line card converts incoming analog signals into digital signals which are then passed on to the peripheral controller. This conversion is accomplished by an integrated encoder/decoder (codec) chip. There is a codec for each port on the line card. Conversion from digital back to analog is also performed by the codec for outgoing signals. For digital telephones, the codec is located within the telephone set itself.

### PCM

Pulse Code Modulation (**PCM**) is used to convert analog signals to digital signals. The PCM method converts the analog signal to digital by **sampling** the amplitude of the analog signal at a rate of twice the highest signal frequency and converting the amplitude of each sample into a series of coded pulses. The PCM sampling frequency standard for telecommunications is 8 kHz.

Companding (compressing - expanding) PCM is a standard technique for using 8 bits words to efficiently represent the wide dynamic range of voice and data signals. Two standards for **companding** are internationally recognized:

Mu-255 law for North American applications

A-law for international service

Meridian 1 codecs conform to both standards and are software selectable (in Intelligent Peripheral Equipment Modules) for use in North America and internationally. The codecs are also designed to pass signals up to 3.4 kHz

with minimum time delay and low phase distortion, a requirement for the proper transmission of data signals.

### **Remote Peripheral Equipment (RPE)**

In a local operating environment, the peripheral equipment may be housed up to 50 feet from the common equipment. The RPE feature extends this range to approximately 70 miles between local and remote facilities. This extension is made possible by converting the multiplexed loop signals to a form compatible with the commonly used T-1 type digital transmission system.

Any medium conforming to DS-1 format (1.544 Mbps) may be used to link local and remote sites, including digital microwave radio and fiber optic transmission systems.

### **DTI/PRI**

Allocation of circuit-switched bandwidth may also be made on a network loop basis to Primary Rate Access (PRA) or Digital Trunk Interface (DTI) circuits. These optional services are based on the standard T-1 format (DS-1 24 channel) used in digital transmission networks.

DTI allows for the replacement of 24 conventional analog trunks by a single T-1 digital link. Each of 24 channels provides up to 56 Kbps for voice and synchronous data transmission, or up to 19.2 Kbps for asynchronous data.

## **Power equipment**

Meridian 1 systems feature a modular power distribution architecture which parallels the modular design concept of the Universal Equipment Module. Meridian 1 power systems provide the following features:

- AC-powered and DC-powered system options, providing flexibility to meet a wide range of customer requirements.
- A distributed, modular power architecture, with power supplies located in each Module, rather than in separate, centralized power shelves.
- All DC systems are available as complete systems, with rectifiers provided by Northern Telecom, or can be equipped for customer-provided external power.

- A new System Monitor has been designed to provide enhanced power, cooling, and general system monitoring capabilities. This new System Monitor interfaces to the CPU via a Serial Data Interface card, for intelligent error and status reporting.
- Maintenance messages that indicate the location of power faults and status down to the specific Column and Module.
- Equipment modules that are truly Universal, in terms of power and cooling. Meridian 1 systems are designed to eliminate power and thermal **limitations**: any card can go in any slot, and all modules can be filled to capacity with any logically valid combination of cards, with virtually no engineering rules.
- A universal quick-connect power wiring harness is used to distribute input voltages and monitor signals to power supplies located in each Module.
- An advanced cooling system which employs forced air impellers. The velocity of the impellers is automatically adjusted to meet the cooling requirements of the system.
- Fuses are eliminated, as the system exclusively uses circuit breakers for input power protection.
- Modular backup capabilities.

AC and DC systems differ primarily in the power components external to the UEM. See Figures 8 and 9 for block diagrams of the AC and DC powering schemes. DC systems always require the use of rectifiers. This can be a disadvantage in applications that do not require reserve power backup in the event of a utility power failure. The use of a rectifier in DC powering is an advantage in applications that do require battery backup, since all that is needed is to add batteries, as in the traditional central office powering scheme.

AC-powered systems are especially well-suited for those applications that do not require reserve power, as there are no external power components required. There are a wide variety of Uninterruptible Power Supply (UPS) systems available for AC systems that require reserve power, and the use of a UPS is an effective method of providing backup power in many situations.



The choice of which powering scheme to use is determined primarily by reserve power requirements and preferences, and by existing power equipment at the installation site.

**Figure 10**  
**AC power architecture**

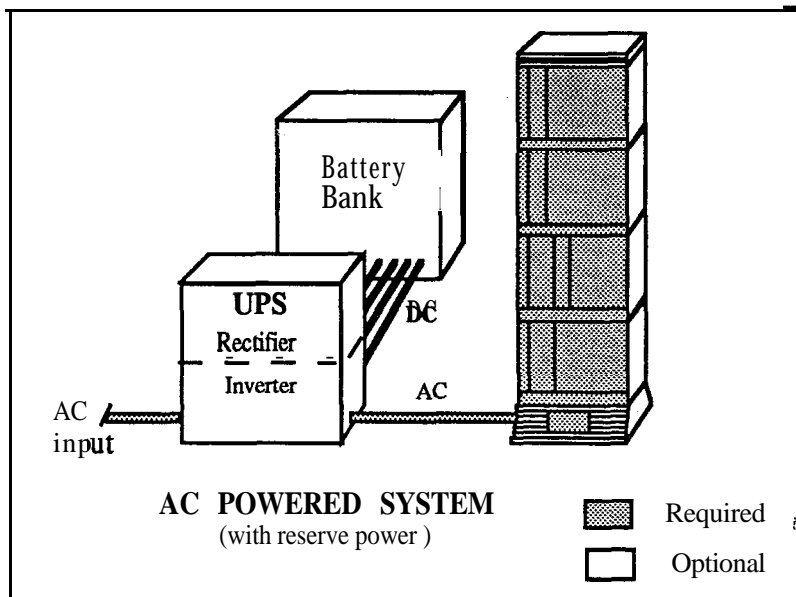
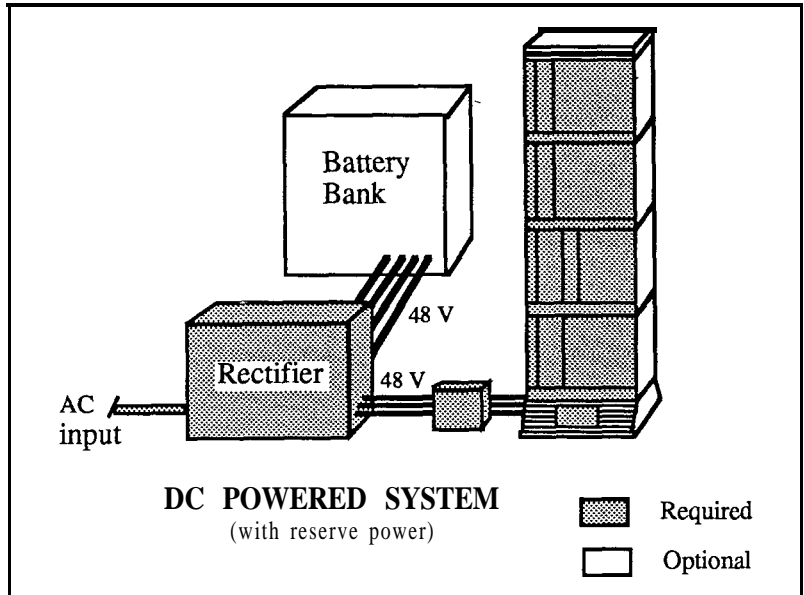

Figure 11  
DC power architecture





---

## Product description

---

### Universal Equipment Modules

The Meridian 1 System is comprised of Universal Equipment Modules (**UEMs**), each containing everything needed (card cage assembly, power supply, I/O cabling, etc) to support a specific system function. These **UEMs** are assembled up to four high on a pedestal, to form a column. The pedestal contains a central Power Distribution Unit (**PDU**), cooling fans, air filters, and a System Monitor circuit. At the top of each column is a Top Cap, which consists of two air exhaust grilles and a thermal sensor assembly that works in conjunction with the System Monitor. Systems are comprised of one or more columns. Each Universal Equipment Module is available in AC or DC powered versions.

The Universal Equipment Modules are constructed of die cast aluminum, providing strength and durability. For ease of access each module has removable front and rear covers. All cable routing between the module and the Main Distribution Frame (**MDF**) is handled through the rear of the module. Cable exit can occur at the top, to access overhead cable racks, or at the bottom to take advantage of raised floors. Universal Equipment Modules are assembled on a pedestal that houses a central Power Distribution Unit, cooling units and system monitor circuitry. The pedestal can be equipped with either leveling feet or casters. **UEMs** may be assembled in columns up to four high.

The following Universal Equipment Modules are available:

- CPU module (**NT8D34**)
- CPU/Network module (**NT6D39**)
- Network Equipment module (**NT8D35**)

- Common/Peripheral Equipment module (NT8D11)
- Intelligent Peripheral Equipment module (NT8D37)
- Peripheral Equipment module (NT8D13)
- Remote Peripheral Equipment Carrier module (NT8D47)
- InterGroup module (NT8D36AA)
- Meridian Mail module (NT6D44)

Figure 12  
Universal Equipment Modules

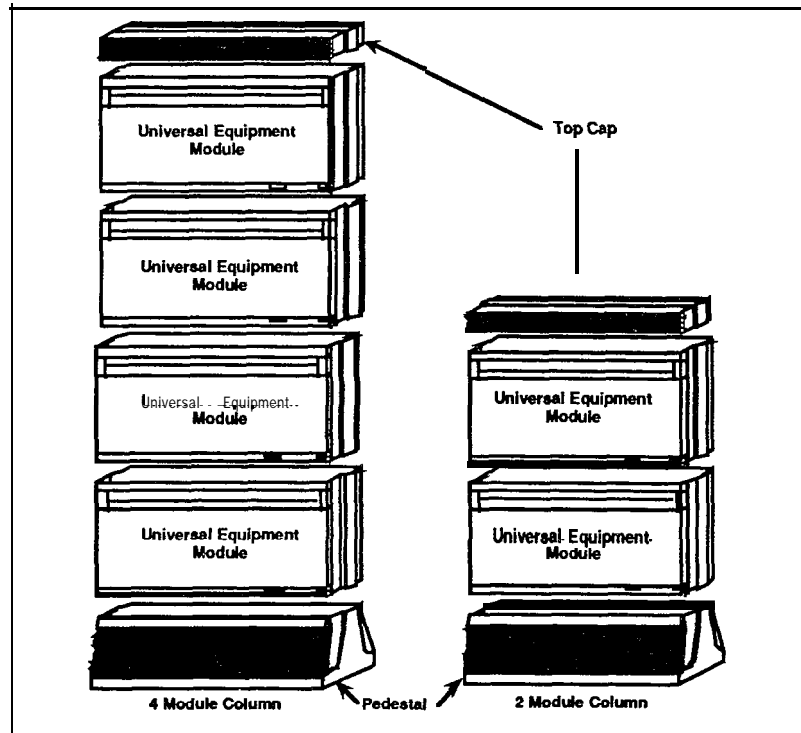

---

## CPU module (NT8D34)

The **NT8D34** CPU module houses the CPU and Memory cards used to provide system control and storage of data and programs, for the Meridian 1 system option 71. Each **NT8D34** CPU module houses one CPU; two are required for the Meridian 1 system option 71. For configuration flexibility the **NT8D34** CPU module is available with an AC power supply option or a DC power supply option. These power supplies provide the voltages to operate the circuit cards located in the modules.

The **NT8D34** CPU module contains 17 card slots which support the following:

- slots 1-2 : Memory
- slot 3: CMA
- slot 4: CPU Interface
- slot 5: CPU Function
- slot 6: SDI
- slot 7: MSI
- slots 8-12: Segmented Bus Extender (SBE)
- slot 14: Clock Controller
- slot 15- 17: FDU/MDU or Digital Trunk Interface (DTI)/Primary Rate Interface (PRI)



## CPU/Network module (NT6D39)

The NT6D39 CPU/Network module houses the CPU and Memory circuit cards used to provide system control and storage of data and programs for Meridian 1 system option 51 and 61. Each NT6D39 module houses one CPU and up to 16 network loops required for each Meridian 1 system option 51 and 61.

For configuration flexibility the NT6D39 CPU/Network module is available with an AC power supply option or a DC power supply option. These power supplies provide the voltages to operate the circuit cards located in the Modules.

For a half group, single CPU system (Meridian 1 system option 51) one NT6D39 module is required. For a full group, dual CPU system (Meridian 1 system option 61) two NT6D39 Modules are required.

The NT6D39 contains 17 card slots which support the following:

- slots 1 - 8: Network cards
- slot 9 : Clock Controller or Serial Data Interface (SDI)
- slot 10: Peripheral Signaling
- slot 11: 3-Port Extender (3PE)
- slot 12: Mass Storage Interface (MSI)/Floppy Disk Interface (FDI)
- slot 13: SDI
- slot 14: CPU Function
- slot 15: CPU Interface
- slot 16: Changeover Memory Arbitrator (CMA)
- slot 17: Memory
- slot 18: FDU/MDU



Figure 14  
**NT8D39 CPU/Network module -typical configuration**

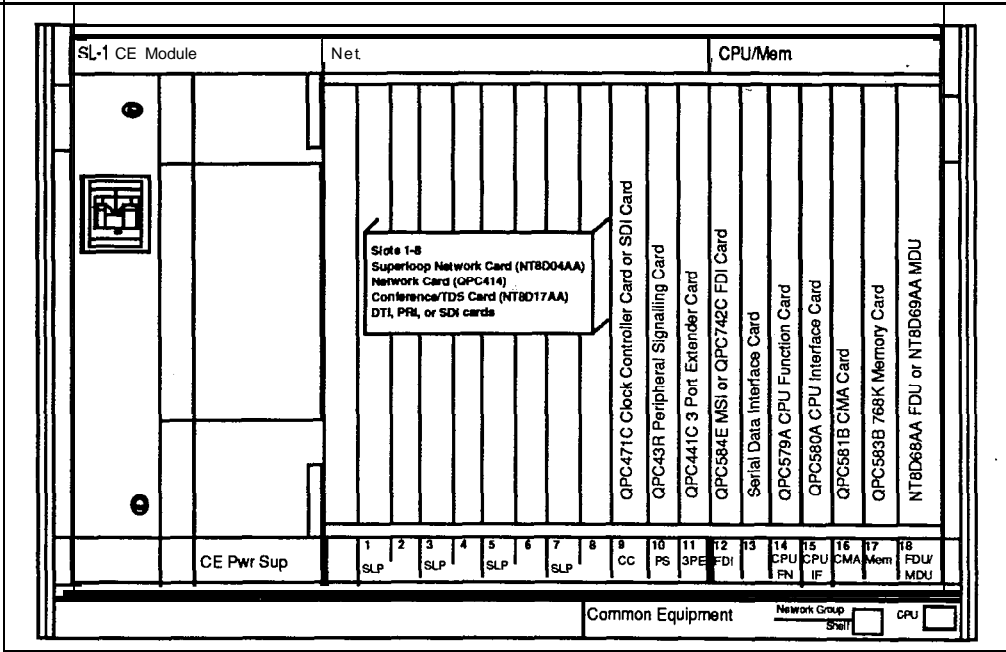

## Network module (NT8D35)

The NT8D35 Network module houses the circuit cards which are used to provide the digital multiplexed network loops of the **switching** system, along with the control and signalling cards **required** to interface the switching function with the CPU. The NT8D35 Network Module is used in Meridian 1 system option 71 only. The NT8D35 module also supports Digital Trunk Interface (**DTI**) and/or Primary Rate Interface (**PRI**) cards.

For configuration flexibility the NT8D35 Network module is available with an AC power option or a DC power option. These power supplies provide the voltages to operate the circuit cards located in the modules.

The NT8D35 Network module houses up to eight QPC414 (**ENET**) cards or four NT8D04AA **SuperLoop** Network cards, or any combination for a total of 16 network loops per module. In a typical configuration, 14 voice/data loops are available when one NT8D17 Conference/Tone and Digit Switch card is configured in the module. Two NT8D35 modules are required to make a full network group of 32 loops. A maximum of 10 NT8D35 Modules (5 network groups) may be configured.

The NT8D35 contains 15 card slots which support the following:

- slots 1: 3PE
- slots 2-3: **InterGroup Switch (IGS) 1, DTI/PRI, or SDI**
- slot 4: Peripheral Signaling
- slots 5-12: Network Cards
- slot 13: **DTI/PRI or SDI/QSDI**
- slot 14: **DTI/PRI**
- slot 15: not used

44 Product description

**Figure 15**  
**NT8D35 Network module — typical configuration**

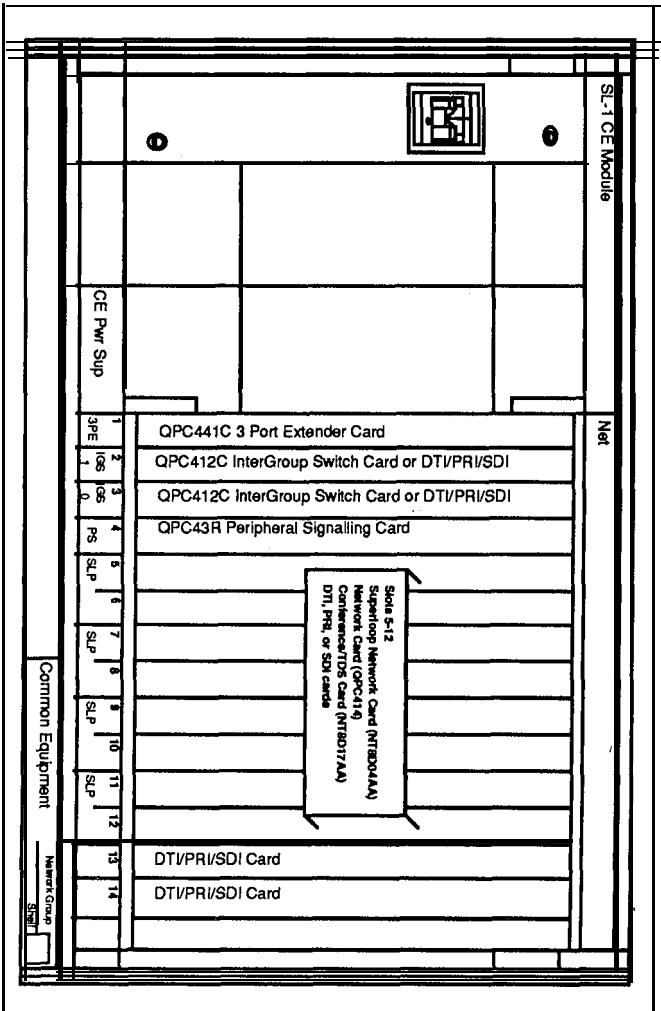

## Common/Peripheral Equipment modute (NT8D11)

The NT8D11 module houses the common, network and peripheral equipment circuit cards for Meridian 1 system options 21A and 21.

The NT8D11 CE/PE module is available **in two** versions, AC or DC power. These power supplies provide **the** voltages to operate the circuit cards located in the modules.

The NT8D11 CE/PE module is divided into two functional sections:

- Common Equipment (CE)
- Peripheral Equipment (PE)

There are 10 Common Equipment (CE) and 10 Peripheral Equipment (PE) card slots. The CPU functions are provided by card slots 1-3. The Network Equipment functions are provided by card slots 3-10.

The NT8D11 module will utilize two **specially** designed circuit cards for Meridian 1 System Options 21A and 21 only.

- Memory/Signaling card (NT8D19AA) — provides the peripheral signaling functions in addition to providing the memory and miscellaneous CPU equipment functions.
- Network/DTR card (NT8D18AA) — provides the Controller card -- (NT8D01) functions for the Intelligent PE cards installed in the NT8D11 module, along with a **SuperLoop** Network and **Digitone** Receiver functions.

The NT8D11 module uses the new Intelligent Peripheral Equipment cards to provide trunk and station interface in system options 21A and 21.

The **NT8D11 CE/PE Module** contains 20 card slots which support the following:

- slot 1 : FDI
- slot 2 : CPU
- slot 3: Memory
- slots 4-8: Network cards
- slot 9: Conference/Tone and Digit Switch card (**NT8D17AA**)
- slot 10: **Network/DTR** card (**NT8D18AA**) (Always configured as **SuperLoop** 28)
- slots 0-9: Intelligent Peripheral Equipment cards only

Figure 16  
NT8D11 CE/PE Module — typical configuration

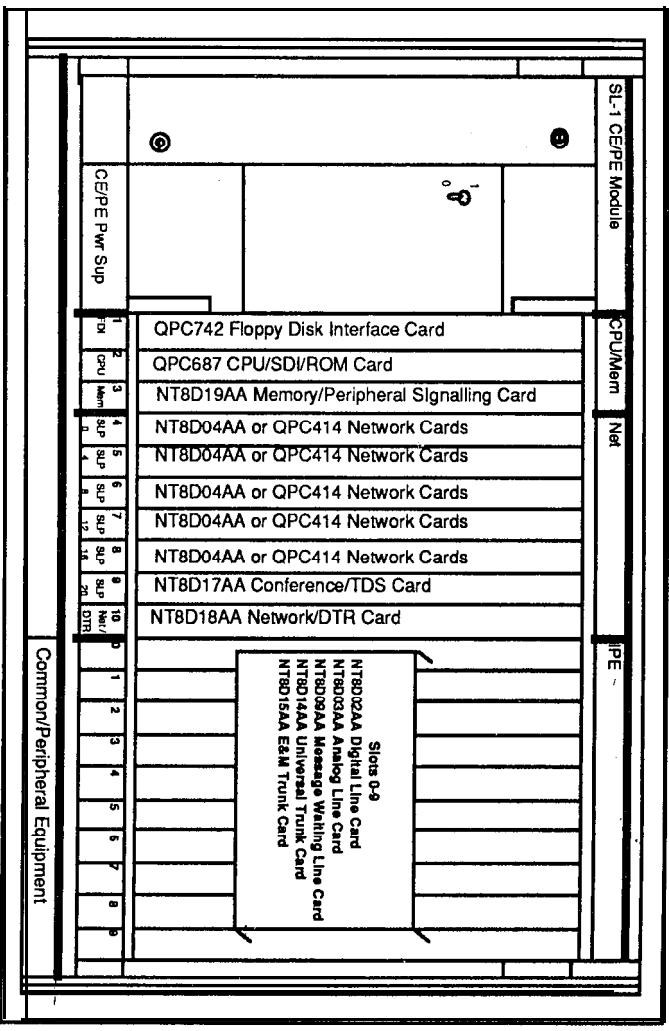

## Intelligent Peripheral Equipment module (NT8D37)

The Intelligent Peripheral Equipment module uses the new Peripheral Equipment cards only and may be used with system options **21A, 21, 51, 61, 7** 1. With an upgrade assembly the Intelligent Peripheral Equipment modules may be used **with** all existing systems.

The **NT8D37** Intelligent PE module is available in two versions, AC or DC power. These power supplies provide the voltages to operate the circuit cards located in the modules.

The **NT8D37** module may only be connected to a **SuperLoop** Network (**NT8D04AA**) circuit card. It houses one Controller card (**NT8D01**) and up to 16 Intelligent Peripheral Equipment circuit cards. The card slots are numbered **from** 0 to 15, for a total of 16 PE card slots.

The **NT8D37** Intelligent PE module supports 16 PE circuit cards, yielding a capacity of 256 Integrated Voice/Data (IVD) lines (512 **TNs**), although a typical configuration includes a mixture of Digital lines, Analog lines, Trunks and **Digitone** Receiver (DTR) circuit cards.

All cable connections to the MDF are made in the rear of the module through an I/O panel. To serve all 16 PE card slots, 12 PE cables are required to the MDF.

Figure 17  
 NT8D37 Intelligent PE module-typical configuration

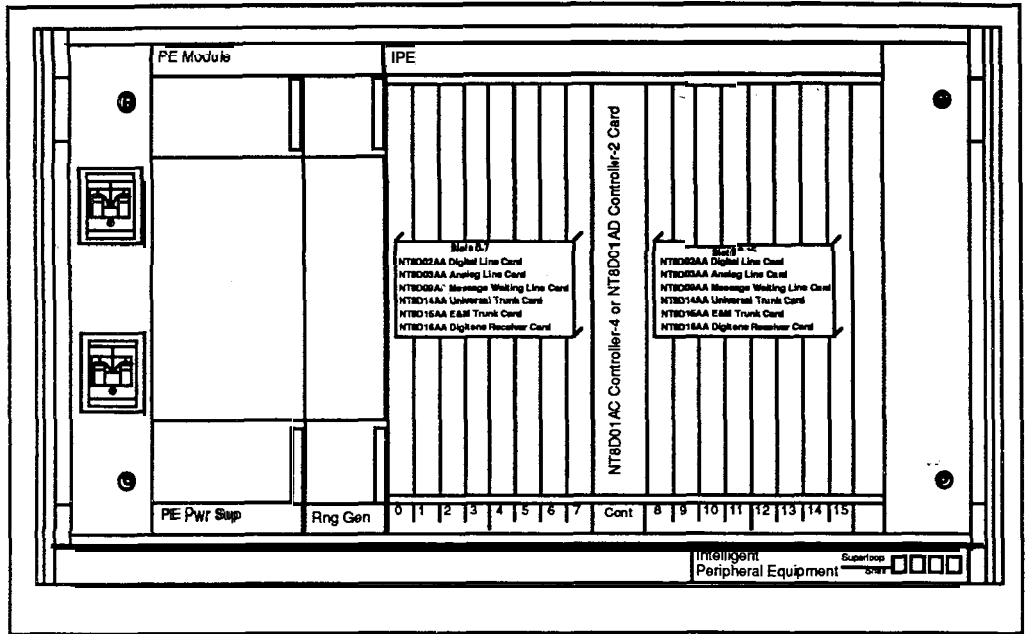



## Peripheral Equipment module (NT8D13)

The Peripheral Equipment module uses the PE circuit cards currently housed in PE shelves for the Meridian SL-1 systems. It provides the interface to the system for trunks and stations. The **NT8D13** module may only be connected to an ENET (QPC414) circuit card and maybe used in system options **21A, 21, 51, 61, 71** and the Meridian **SL-1XT, NT, RT, ST, N,** and **XN** systems. It houses one Peripheral Buffer circuit card (QPC659) and up to ten existing peripheral equipment circuit cards.

When the Meridian Data Service ADM, SADM, ASIM or AIM are required on system options **21A, 21, 51, 61,** and **71,** the **NT8D13** PE module must be used.

For configuration flexibility the **NT8D13** Peripheral Equipment module is available with an AC power supply option or a DC power supply option. These power supplies provide the voltages to operate the circuit cards located in the Modules.

All cable connections to the MDF are made in the rear of the module through an I/O panel. Seven PE cables are required to the MDF for all 10 card slots.

**Figure 18**  
**NT8D13 PE module — typical configuration**

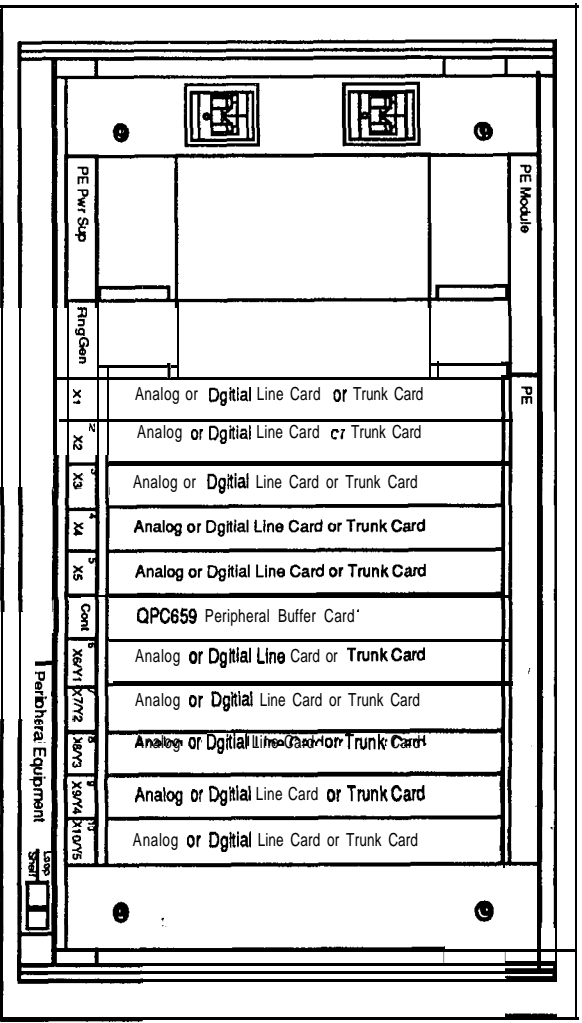

## Remote Peripheral Equipment Carrier module (NT8D47)

The NT8D47AA/DC RPE Carrier module is used to extend the Network to PE interconnection distance between local and remote sites. It accommodates two network loops. The number of modules required per system depends on the number of stations in the remote site.

For configuration flexibility the Remote Peripheral Equipment Carrier module is available with an AC power option or a DC power option. These power supplies provide the voltages to operate the circuit cards located in the modules.

The RPE backplane contains 12 card slots which support the following:

- slot 1: DTI
- slot 2: 1.5 Mb Converter
- slot 3: 2 Mb Converter
- slot 4: Carrier Interface
- slot 5: Remote Peripheral
- slot 6: Local Carrier Buffer
- slot 7: Carrier Interface
- slot 8: 2 Mb Converter
- slot 9: 1.5 Mb Converter
- slot 10: Carrier Maintenance
- slots 11-12: DTI

Figure 19  
 NT8D47 RPE Carrier module -typical configuration

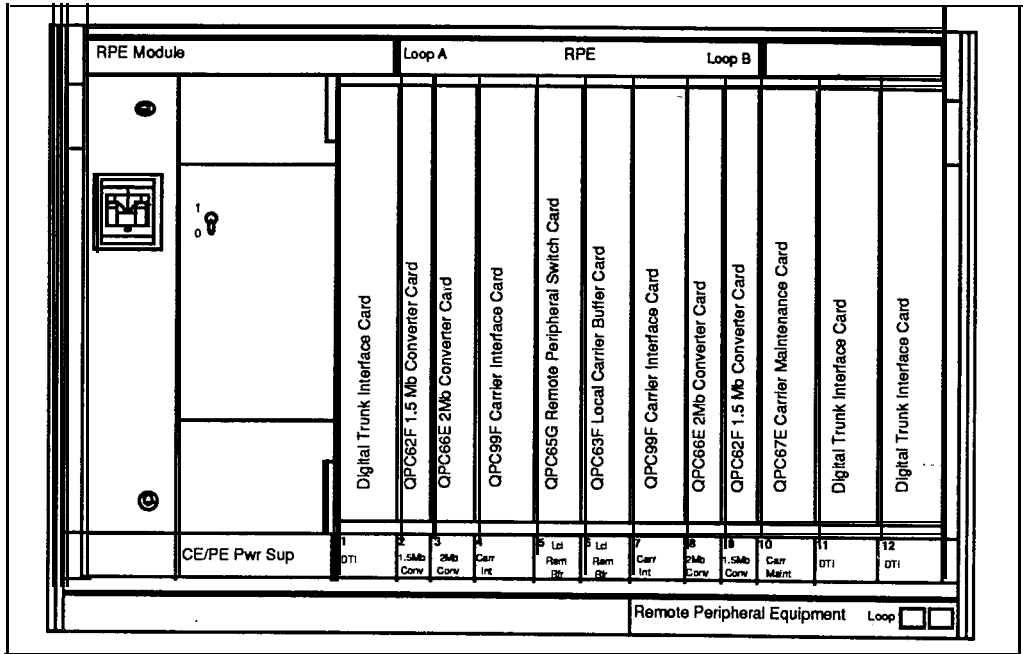

## InterGroup module (NT8D36AA)

The **InterGroup** module provides a path for the switching of **traffic** between the network groups in system option 71. Faceplate cables from Segmented Bus Extender (SBE), System Clock (SCG) and **InterGroup** Switch (IGS) circuit cards are connected to the **InterGroup** module. These faceplate cables are accessed from the front of the module.

The **InterGroup** module does not require any power card for operation. Therefore it may be used with systems using the AC power option or the DC power option.

Figure 20  
NT8D36AA InterGroup module

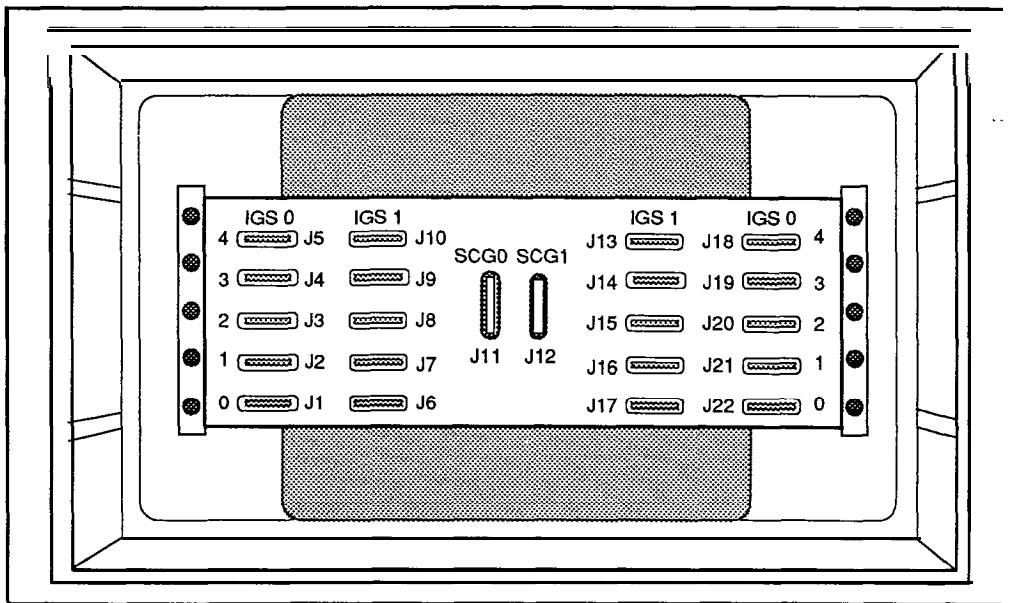

## Meridian Mail module (NT6D44)

The **NT6D44** Meridian Mail module houses the circuit cards currently used by the Meridian Mail Option for Meridian SL-1 systems: The **NT6D44** Meridian Mail module may only be connected to an ENET (QPC4 14) circuit card and may be used in Meridian 1 system options **21A, 21, 51, 61, 71** and the Meridian SL-1 XT, NT, RT, ST, N, and XN systems.

For configuration flexibility the **NT6D44** Meridian Mail module is available with an AC power supply option or a DC power supply option. These power supplies provide **the** voltages to operate the circuit cards located **in** the Modules.

Meridian 1 system option 21A must be upgraded to Meridian 1 system option 21 when the **NT6D44** Meridian Mail module is equipped.

Figure 21  
Meridian Mail module -typical configuration

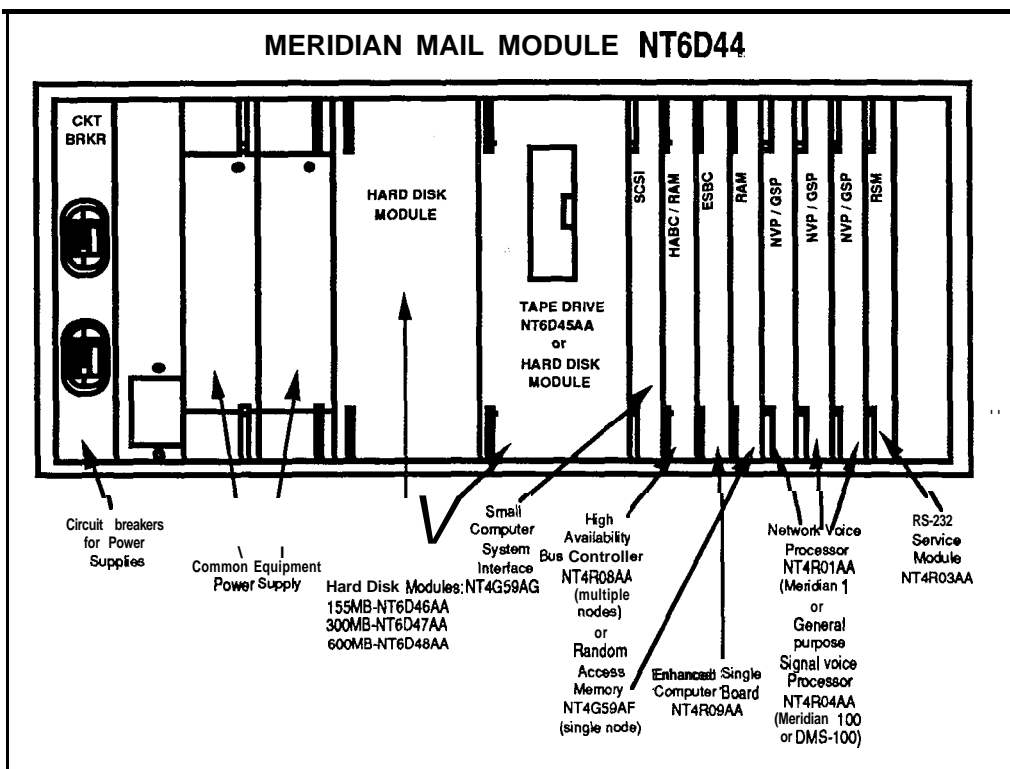

## Pedestal (NT8D27AB)

The NT8D27AB pedestal is a base unit made of die-cast construction and houses the power distribution unit, system monitor, blower unit, and fan unit connector. One pedestal is required per equipment column.

The pedestal is approximately 31.5 inches wide by 25.50 inches deep by 10 inches high and weighs 30 lbs empty. Leveling feet are provided for up to four tiers, while a caster option is provided for up to two tiers. Input power for the system is brought into and distributed by the pedestal. A Power Distribution Unit located in the pedestal contains an **EMI** filter and one 30 amp circuit breaker.

One pedestal distributes the input power for one column. Also located in the pedestal are two forced air impellers and a reusable dust filter. The impellers are protected by two 1 amp circuit breakers.

## Top cap (NT7D00)

The top cap is mounted on the top module of each column. It provides additional **EMI** shielding, air exits, and I/O cable exits.

The top cap is approximately 31.5 inches wide by 22 inches deep by 3 inches high and weighs 8 lbs. It consists of a front and a rear air exhaust grills, each secured by two clips underneath the edge of the grill.

Three versions of the top cap are available:

- NT7D00AA AC systems
- NT7D00BA DC systems
- NT7D00AB Meridian 1 System option 21A only

## Expansion kit (NT8D49)

The Expansion kit bolts modules together for side-by-side expansion when in a contiguous row. The Expansion kits also maintain shielding against **EMI/RFI**. See Figures 22 and 23.



**Figure 22**  
Multi-column system equipped with NT8D49 Expansion kits

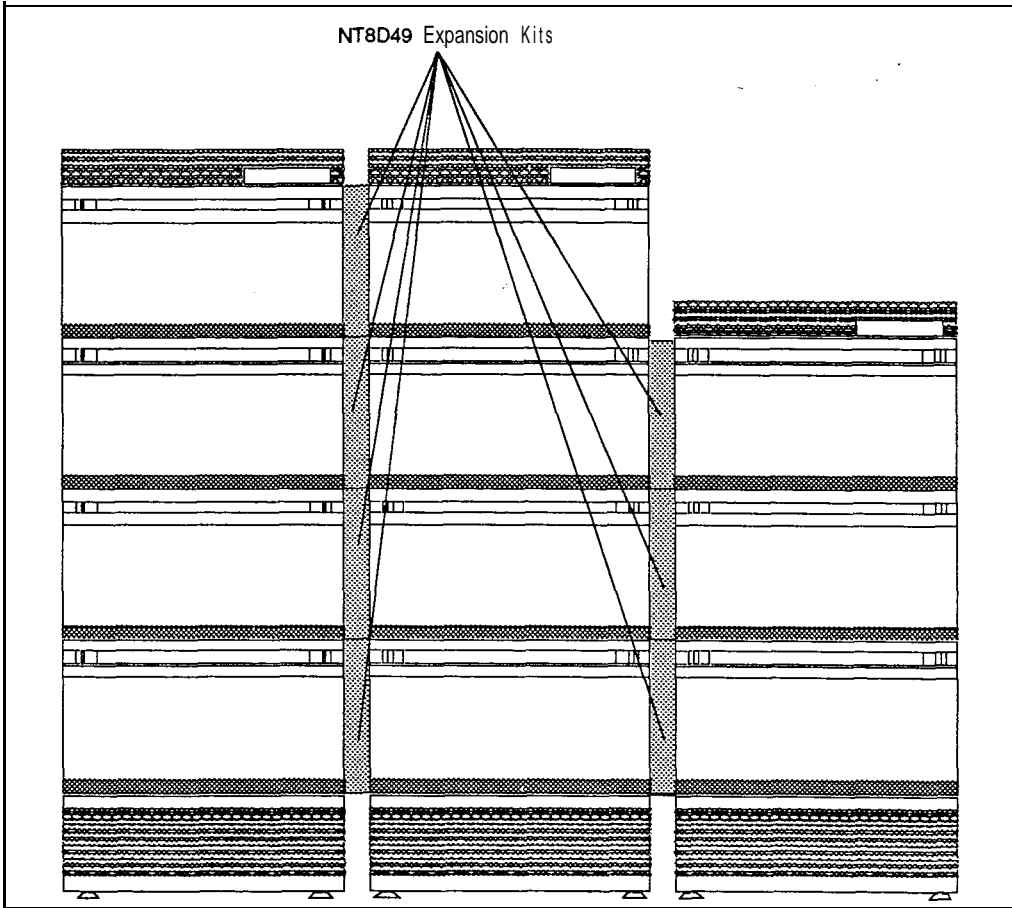

**Figure 23**  
**NT8D49 Expansion kit**

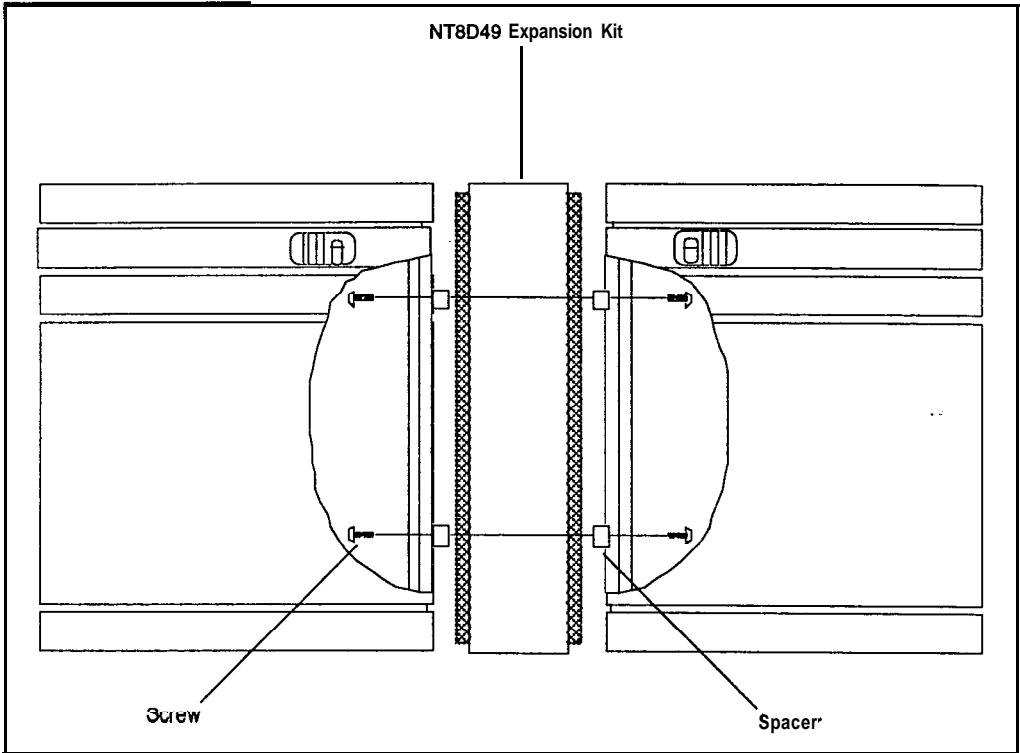

## Meridian 1 system options

Several system options are available. The use of the Universal Equipment Modules allows for seamless growth from one option to another by adding or replacing Universal Equipment Modules or card cages. The options are selected depending upon the application, line size, and other customer requirements:

- Meridian 1 system option 21A — Single CPU-I module only
- Meridian 1 system option 21 — Single CPU
- Meridian 1 system option 51 — Single CPU, Half Network Group
- Meridian 1 system option 61 — Dual CPU, Full Network Group
- Meridian 1 system option 71 — Dual CPU, Multiple Network Groups

### Meridian 1 system option 21A

The Meridian 1 system option 21A package includes the **CE/PE** base hardware, 1 **Network/DTR** card, 1 **Conf/TDS** card, 1 Floppy Disk Unit (FDU), 2 **SDI** paddle boards. The Pedestal and Top Cap assemblies must be added. These assemblies include a **Top Cap-21A**, **System Monitor-21A**, Pedestal, AC power cord and a power distribution Unit-21A. The Meridian 1 system option 21A supports only the AC power option.

**Figure 24**  
**System option 21 A**

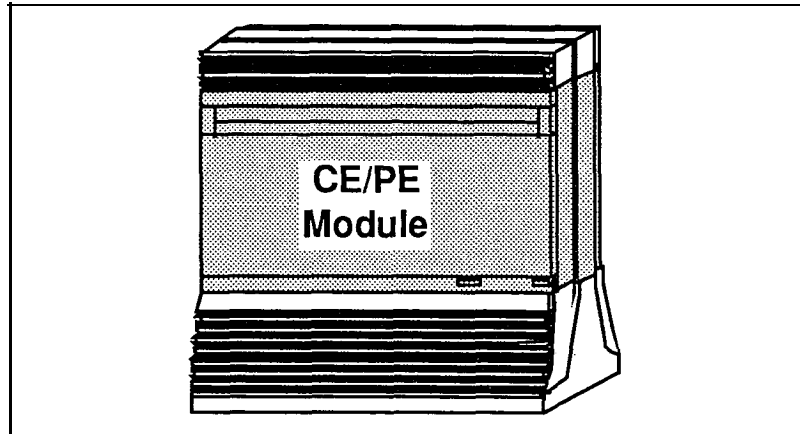

Table 1  
System **option 21A specifications**

<b>Power</b>	<b>AC only</b>
Typical Number of Ports	160
Maximum Number of Ports	320
Maximum Number of Modules	1
AC Input Voltage	208 V ac
Number of CPUs	1
Number of Network Loops	7 <b>SuperLoops</b> or 12 ENET Loops plus two service loops ( <b>Conf/TDS</b> )
Cooling	Fan in Top Cap
Memory	768K
Data Storage	Floppy Disk Unit
Software Generic	1011 <b>Rls</b> 15
Hardware Features	No Power Distribution Unit Contains System Monitor ( <b>NT7D15AA</b> )

*Note:* Additional network loops require expansion modules (Intelligent PE or Peripheral Equipment Modules).

## Meridian 1 system option 21

The Meridian 1 system option 21 package includes the **CE/PE** base hardware, 1 **Network/DTR** card, 1 **Conf/TDS** card, 1 Floppy Disk Unit (**FDU**), 2 **SDI** paddle boards. The Pedestal and Top Cap assemblies must be added. Figure 25 illustrates a typical configuration with the shaded area showing the base package.

**Figure 25**  
System option 21

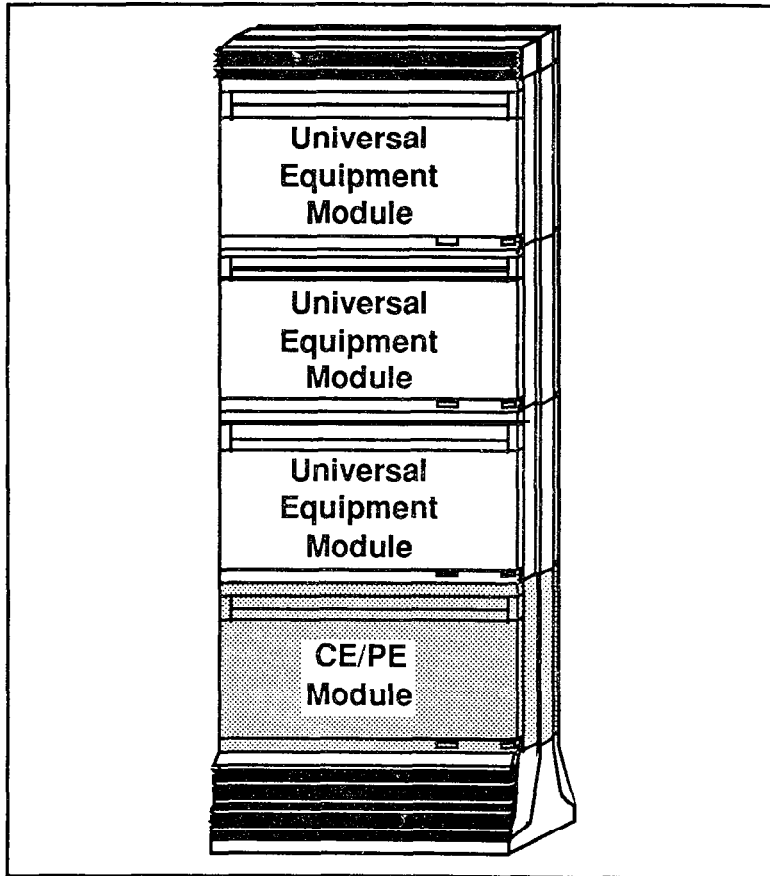

**Table 2**  
**System option 21 specifications**

Power	AC or DC
Maximum Number of Ports	800
Input Voltage	<b>208 V ac or -48 V dc</b>
Number of CPUs	1
Number of Network Loops	7 <b>SuperLoops</b> or 12 ENET Loops plus two service loops <b>(Conf/TDS)</b>
Cooling	Fan Impellers in pedestal
Memory	768K
Storage Media	Floppy Disk Unit
Software Generic	1011 Rls 15
Hardware Features	Standard Power Distribution Unit Contains System Monitor <b>(NT8D22AB)</b>

## Meridian 1 system option 51

The Meridian 1 system option 51 package includes 1 CPU/Network module, 1 Conference and TDS card, 1 SuperLoop Network card, 2 SDI paddle boards, 1 Intelligent Peripheral Equipment module, 1 Pedestal assembly and 1 Top Cap. The FDU or MDU assembly must be added. Figure 26 shows a typical system configuration with the shaded areas showing the base package.

Figure 26  
System option 51

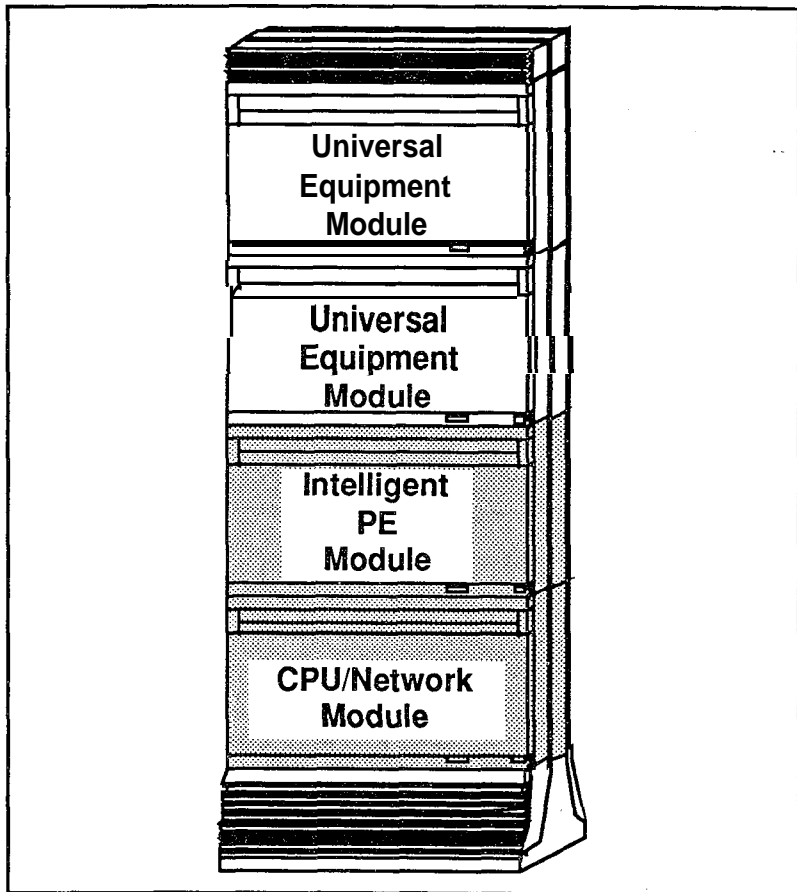

**Table 3**  
**System option 51 specifications**

Power	AC or DC
Maximum Number of Ports	1000
Input Voltage	<b>208 V ac or -48 V dc</b>
Number of CPUs	1
Number of Network Loops	16
Cooling	Fan Impellers in pedestal
Memory	768K
Storage Media	Floppy Disk Unit or Multi Disk Unit
Software Generic	1111 Rls 15
Hardware Features	One Half Network Group, Standard Power Distribution Unit Contains System Monitor (NT8D22AB)



### Meridian 1 System option-61

The Meridian 1 System option 61 package includes 2 CPU/Network Modules, 2 Conference and TDS cards, 1 **SuperLoop** Network card, 2 **SDI** paddle boards, 1 Intelligent Peripheral Equipment module, 1 Pedestal assembly and 1 Top Cap. The FDU or MDU assembly must **be added**. Figure 27 shows a typical system configuration with the shaded areas showing the base package.

Figure 27  
System option 61

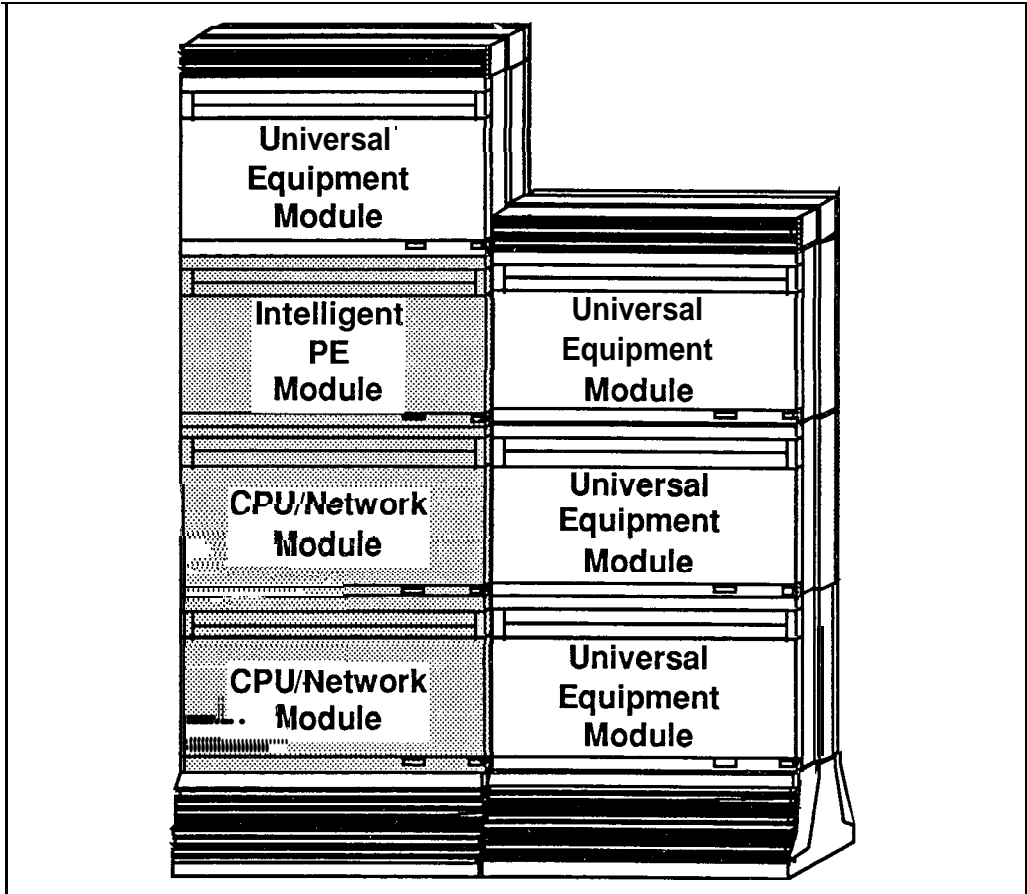

**Table 4**  
**System option 61 specifications**

Power	AC or DC
Maximum Number of Ports	2000
Input Voltage	<b>208 V ac or -48 V dc</b>
Number of <b>CPUs</b>	2
Number of Network Loops	32
Cooling	Fan Impellers in pedestal
Memory	768K
Storage Media	Floppy Disk Unit or Multi Disk Unit
Software Generic	<b>1111</b> Rls 15
Hardware Features	One Network Group, Standard Power Distribution Unit and Contains System Monitor <b>(NT8D22AB)</b>

## Meridian 1 system option 71

The Meridian 1 system option 71 package includes 2 CPU Modules, 1 **InterGroup** module, 1 Network Group assembly, 2 Conference and TDS cards, 1 **SuperLoop** Network card, 2 **SDI** cards, 2 **Intelligent** Peripheral Equipment Modules, 2 Pedestal assemblies and 2 Top Caps. The FDU or MDU assembly must be added. Figure 28 shows a typical configuration with the shaded areas showing the base package.

Figure 28  
System option 71

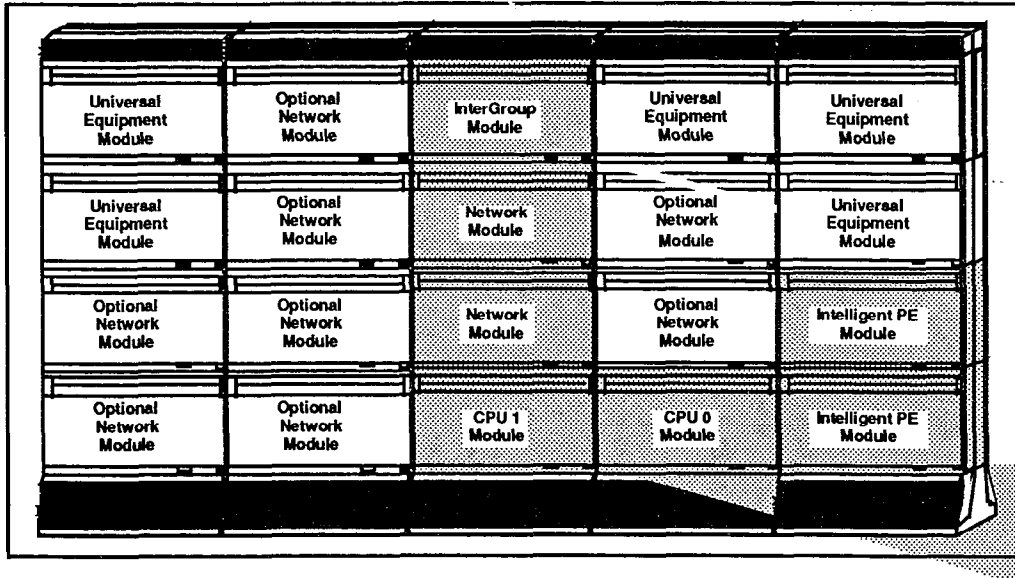

**Table 5**  
**System option 71 specifications**

Power	AC or DC
Maximum Number of Ports	10,000
Input Voltage	208 V ac or -48 V dc
Number of CPUs	2
Number of Network Loops	160
Cooling	Fan Impellers in pedestal
Memory	1.5 Mbyte
Storage Media	Floppy Disk Unit or Multi Disk Unit
Software Generic	1211 Rls 15
Hardware Features	Up to five Network Groups, Standard Power Distribution Unit and Contains System Monitor (NT8D22AB)



---

## List of terms

---

<b>ACD</b>	Automatic Call Distribution.
<b>ADM</b>	Add-On Data Module.
<b>AIM</b>	Asynchronous Interface Module.
<b>ALU</b>	Arithmetic Logic Unit.
<b>Architecture</b>	The interrelationship between the parts of a system. The framework of a system.
<b>ASIM</b>	Asynchronous/Synchronous Interface Module.
<b>Analog</b>	A process which models information in the form of a continuously varying parameter such as current, voltage, or phase.

**Analog signal**

A signal that varies in a continuous manner such as voice or music. An analog signal may be contrasted with a digital signal which represents only discrete states. The signal put out by a data set **has** both analog **and** discrete characteristics.



**ANI**

Automatic Number Identification.

**Ampere**

A unit of electrical current or the rate of flow of electricity which is equal to watts divided by volts.

**Backplane**

A printed circuit board that extends throughout the length of the shelf and connects **to** the circuit pack connectors. Also known as a motherboard.

**Battery back-up**

System power furnished by stand-by batteries that are charged by a charger. If commercial power fails, the batteries will maintain service for a limited period of time determined by the size of the batteries and the traffic on the system.

**BISDN**

Basic Rate Integrated Services Digital Network.

**BTU**

British thermal unit. The quantity of heat required to raise the temperature of one pound of water one degree Fahrenheit at a specified temperature (as 39° F). Also means Bus Terminating Unit.

**Capacity**

The information-carrying ability of a telecommunications facility, group, network, or system measured in Bits Per Second.

**Cards**

See circuit packs.

**Card Cage**

Also referred to as card chassis. A frame for holding circuit cards in a microprocessor. A standard cage holds nine cards; units with motherboards can hold up to 20 cards.



<b>CAS</b>	Centralized Attendant Service.
<b>CASM</b>	Centralized Attendant Service, Main.
<b>CASR</b>	Centralized Attendant Service, Remote.
<b>CC</b>	Clock Controller.
<b>CDR</b>	Call Detail Recording.
<b>CE</b>	Common Equipment.
<b>Central Office (CO)</b>	The site where the telephone companies terminate customer lines and locate the switching equipment which interconnects those lines.
<b>Central Processing Unit (CPU)</b>	The main portion of a computer that contains the primary storage, arithmetic and logic units, and the control unit; Mainframe.
<b>Centralized depot</b>	A repair house for SL-1 systems that serves subdepots.
<b>Centrex</b>	Central Exchange. A telco PBX type of service incorporating Direct Inward Dialing (DID) and Automatic Identification of Outward Dialed Calls (AIOD).
<b>Circuit packs</b>	Also known as cards, circuit packs are individual circuit boards that carry the necessary electronics for particular functions (memory, disk drive control, etc. ). These cards fit into expansion slots provided by Apple, IBM, Radio Shack, and other computer manufacturers.
<b>CMA</b>	Changeover and Memory Arbitrator.



**CO**

Central Office.

**CPU**

Central Processing Unit.

**Common equipment (CE)**

A hardware subsystem that houses one or more Central Processing Units (CPUs), memory circuits, mass storage devices, and service circuits.

**Configuration**

A group of machines (hardware) which are interconnected and are programmed to operate as a system.

**Data Terminal Equipment (DTE)**

Equipment or devices which are capable of transmitting and/or receiving data signals over a communications network commonly called a business machine.

**dB**

Decibel

**DCHI**

D-Channel Handler Interface.

**Diagnostic programs**

Software routines used to test equipment and pinpoint faulty components.

**Digital**

A process which models information as discrete values of some parameter such as voltage, current, or phase. Compare with analog.

**Digital Multiplex Switching System (DMS)**

A family of switching systems using new technology that provides digital circuit switched service for voice and data transmission. DMS is characterized by the use of pulse code modulation (PCM) and time division multiplexing (TDM) throughout the switched network. The system allows the direct switching of PCM signals without their conversion to analog format.

**Digital signal**

A signal made up of discrete, non-continuous pulses whose information is contained in their duration, periods, and/or amplitude.

**Directory number**

The four-digit number or extension given to a Meridian SL-1 telephone set. Also known as DN.

**DSL**

Digital Subscriber Loop.

**DTE**

Data Terminal Equipment.

**DTI**

Digital Trunk Interface.

**DTR**

Digitone Receiver.

**EIA**

Electronics Industry Association.

**EMI**

Electromagnetic Interference. Unwanted electromagnetic coupling. Examples are ham radio heard on electric organs and church music heard in hearing aids. Also known as QRM or "static."

**ESN**

Electronic Switched Network.

**Failure rate**

The estimated number of failures for that item during one million (10<sup>6</sup>) hours of operation.

**Firmware**

A set of instruction sequences stored permanently in hardware (ROM).

**FM**

Frequency Modulation; A process whereby the frequency of a previously single frequency carrier wave is varied in step with the amplitude of a complex modulating wave. Also means Fully Modular.

**Frame**

A distributing frame. The structure on which all distribution and trunk cables into a **central** office are terminated (attached).



**Frequency Division Multiplexing (FDM)**

Combining two or more information channels into a single transmission channel by assigning each information channel an exclusive frequency band within the transmission channel bandwidth. (See "Multiplex" and "Time Division Multiplex.")

**I/O**

Input/Output; Refers to devices that communicate with customer equipment. The result equals a properly functioning communications channel or system.

**I/O Channel**

Input/Output channel; A component in a computer system controlled by the central processing unit that handles the transfer of data between main storage and peripheral equipment.

**I/O Panel**

A separation plane that prohibits RF (Radio Frequency) emissions from passing through the cube and provides mounting for I/O cable connectors.

**ISDN**

Integrated Services Digital Network.

**IVD**

Integrated Voice and Data.

**Kb/s**

**Kilobits** per second.

**Line**

A communications channel or **circuit**; an electrical path.

**Loop**

A bidirectional path between network equipment and peripheral equipment.

**MCDS**

Multi-Channel Data System.



---

MDF	Main Distributing Frame. See " <b>Frame</b> " above.
MF	Multi-Frequency; A method of sending numerical address digits between telephone company switching centers coded as two or more frequencies between 300 and 3400 Hertz.
MFS	Multi-Frequency Signaling. Also means Multi-Frequency Sender.
MGS	Multi-Group Switch.
MSI	Mass Storage Interface.
MSL-1	Meridian SL- 1.
MSU	Mass Storage Unit.
Multiplex (MUX)	The process of combining two or more information channels into a single transmission channel. (See "Frequency Division Multiplexing" and "Time Division Multiplexing.")
Network equipment (NET)	A hardware subsystem that provides digital multiplexed switching for voice, data, and signaling paths.
NFT values	The number of spares required for a field-replaceable item. <b>NFT</b> is calculated by multiplying the number ( <b>N</b> ) of that item in use by the failure rate ( <b>F</b> ) for the item from Appendix 1 by the turnaround time ( <b>T</b> ) in hours. ( $N \times F \times T = \text{NFT value.}$ ) See Appendix 1 for details.
NTP	Northern Telecom Publication.

**ODAS**

Office Data Administration System; provides a method of retrieving administrative information stored in Meridian SL-1 memory.

**Office data**

Office data represents system configuration data, peripheral equipment data, and transient data (temporary) used for call processing.

**PBX**

Private Branch Exchange.

**PCM**

Pulse Code Modulation,

**PDU**

Power Distribution Unit.

**PE**

Peripheral Equipment.

**Pedestal**

Base assembly upon which Universal Equipment Modules are stacked; The pedestal houses the Power Distribution Module, System Monitor, Blower Module (and/or Fan assembly), Harnessing, and Air Grille and Filter units.

**Peripheral equipment**

A hardware subsystem that provides analog and digital telephone and trunk interfaces and houses a combination of line, trunk, and receiver packs.

**Population range**

The quantity of each type of SL-1 switch in the area served by a repair-house depot. See Appendix 1 for details.

**Power supplies**

Individual units that generate the different DC voltages required by backplanes installed in a module. Their primary function is to provide power to a shelf of cards housed within a UEM.

**PRA**

Primary Rate Access.

**PRI**

ISDN Primary Rate Interface.

**Private Branch Exchange**

PBX; A small telephone switching center enabling a customer's telephone stations to connect to the public switched network.

**Private Exchange**

A private (manual) telephone exchange that provides private telephone service to an organization that does not allow calls to be transmitted to or from the public telephone network.

**PROM**

Programmable Read-Only Memory.

**Public Switched Network**

The Direct Distance Dialing (DDD) telephone network; Any exchange type of service that is made available for public use.

**Pulse Code Modulation (PCM)**

A modulation technique whereby the signal is converted from an analog to digital format by sampling the signal at periodic intervals and digitizing the amplitude into a finite number of discrete levels; Five-bit information code.

**RAM**

Random Access Memory; Storage system or computer memory that is accessible by the user for either storing or retrieving information. RAM is volatile memory.

**Redundancy**

The duplication of software/hardware used as a standby in case one fails (redundant CPUs).

**Retrofit**

To furnish with new parts or equipment not available at the time of manufacture.

**RF**

Radio Frequency; A group of electromagnetic energy waves whose lengths are between the audio range and the light range.

**RFI**

The disruption of radio **signal** reception caused by any source which generates radio waves at the same frequency and the same path as the desired wave.



**RH**

Relative Humidity.

**ROM**

Read Only Memory: Storage system or computer memory that is “burned into” the microprocessor chip and can only be read, not written to or modified. Non-volatile memory.

**RPE**

Remote Peripheral Equipment.

**Satellite operation**

The operation of a telecommunications system at a remote location as a completely unattended system connected to the main system by special point-to-point circuits. The two (or more) systems act as one total system served by attendants at the main system.

**SBE**

Segmented Bus Extender.

**SDI**

Serial Data Interface.

**SEQ**

Sequencer.

**Single depot**

A repair house that services SL- 1 systems.

**Software**

A set of programmed instruction sequences stored either as resident programs in the system memory or as non-resident programs on disk which are loaded into memory when needed.



**Software generic**

A term used to describe the software package being used. Each software generic (X11, for example), has a series of releases (like release 8).

**Spare stock size**

The quantity of spares for a given stock item.

**Sparing interval**

The period of time that stocks of replaceable SL-1 items should last without being replenished.

**Stock confidence level**

The allowed probability of not being out of stock when the **sparing** interval of one year is greater than 99.9 percent.

**System hardware**

Hardware configuration.

**System monitor**

A microprocessor-based circuit pack used to monitor the UEM (Universal Equipment Module) power supplies, stack thermal status, **and** fan operation status. Each system monitor reports its status to the system CPU, and the head (master) system monitor checks their statuses. The master system monitor will trip the stack circuit breaker in the event of a problem (excessive temperature, for example).

**TCM**

Time Compression Multiplexing.

**TDS**

Tone and Digit Switch.

**Time Division Multiplex (TDM)**

Combining two or more information channels into a single transmission channel by assigning each information channel an exclusive periodic transmission time interval. (See "Multiplex:" and "Frequency Division Multiplex. ")

**Top cap**

A drip-proof cover for the UEM (Universal Equipment Module). It provides airflow exits, RF/EMI shielding, I/O cable entries/exits, and overhead cable-rack mounting.

**3PE**

Three-Port Extender.



**Trunk**

A single circuit between two points, both of which are switching centers or individual distribution points.

**TTY**

Teletype machine.

**2DFi**

Two-Way Tie, Dial Repeating.

**Turnaround time**

The number of days it takes to replace a failed item and to return a useable item to stock.

**UEM**

Universal Equipment Module; a modular, self-contained hardware cabinet (or cube) that houses a card cage assembly, its associated circuit packs, power supplies, and I/O panels. A Meridian SL-1 system may consist of stacks of **UEMs**.

**UPS**

Uninterrupted Power Supply.

**VAC**

Voltage Alternating Current.

**VDC**

Voltage Direct Current.

**VDT**

Video Display Terminal; monitor.



SL-1

## **System options 21, 51, 61, 71**

**System overview**

Copyright © 1990 Northern **Telecom**

All rights reserved.

Information subject to change without notice.

Release 1 .0

Standard

January 29, 1990

Printed in U.S.A.



553-3001-120

SL-1

# System options 21, 51, 61, 71

Installation planning  
Standard

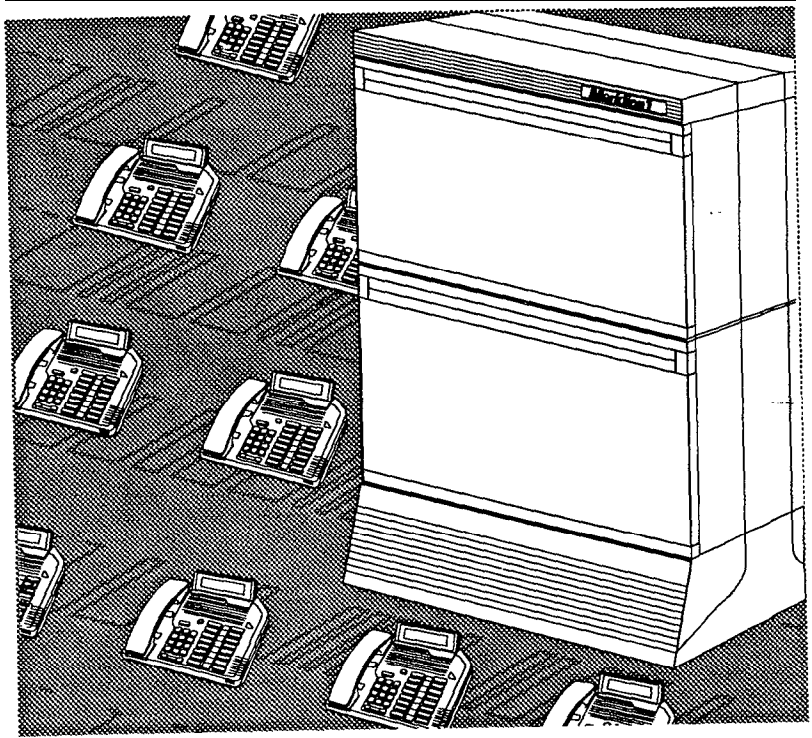

**nt** northern  
telcom

**Meridian 1**  
Communication Systems



---

SL-1

# **System options 21, 51, 61, 71**

## Installation planning

---

Publication number: 553-3001-I 20

Document release: 1 .0

Document status: Standard

Date: January 29, 1990

---

© 1990 Northern Telecom

All rights reserved.

---

installation planning 553-3001-120

---

# Revision history

---

January 29, 1990

Standard, release 1.0

---

# Preface

---

## Notice

The Canadian Department of Communications label identifies certified equipment. This certification means that the equipment meets certain telecommunications network protective, operational and safety requirements. The Department does not guarantee the equipment will operate to the user's satisfaction.

Before installing this equipment, users should ensure that it is permissible to be connected to the facilities of the local telecommunications company. The equipment must also be installed using an acceptable method of connection. In some cases, the company's inside wiring associated with a single line individual service may be extended by means of a certified connector assembly (telephone extension cord). The customer should be aware that compliance with the above conditions may not prevent degradation of service in some situations.

Repairs to certified equipment should be made by an authorized Canadian maintenance facility designated by the supplier. Any repairs or alterations made by the user to this equipment, or equipment malfunctions, may give the telecommunications company cause to request the user to disconnect the equipment.



Users should ensure for their own **protection** that the electrical ground connections of the power utility, telephone lines and internal metallic water pipe system, if present, are connected together. This precaution may be particularly important in rural areas.



**CAUTION**

**Proper electrical ground connections**

Users should not attempt to make electrical ground connections themselves, but should contact the appropriate electrical inspection authority, or electrician, as appropriate.

---

## About this document

---

This section of the Planning and engineering guide deals with planning the environment that the SL-1 (Option 21, 51, 61, and 71) system will inhabit, including equipment location, commercial power requirements (AC and DC), grounding, and cabling requirements. Most of the considerations for site planning and installation are common for both AC- and DC-powered systems. Where there are differences, these are noted in the applicable sections. The information is intended to assist with the site selection, site planning, and installation planning process.

### References

See the *SL-1 planning & engineering guide* for

- ***Muster index*** (553-3001-000)
- System overview (553-3001-100)
- ***Installation planning*** (553-3001-120)
- ***System engineering*** (553-3001-151)
- ***Power engineering*** (553-3001-152)
- ***Spares planning*** (553-3001-153)
- ***Equipment identification and ordering*** (553-3001-154)

See the list of line and trunk circuit descriptions in the ***Muster index*** (553-3001-000) for specific references to lines and trunks.

See the *SL-1 installation and maintenance guide* for

- ***System installation procedures*** (553-3001-210)
- ***Circuit pack installation and testing*** (553-3001-211)

- **Installation procedures for telephone sets and attendant consoles** (553-2201-215)
- **Extended systems installation** (553-3001-250)
- **Disk drive upgrade procedures** (553-3001-251)
- **General maintenance information** (553-3001-500)
- **Fault clearing** (553-3001-510)
- **Hardware replacement** (553-3001-520)

**See the *SL-I XII software guide*** for an overview of software architecture, procedures for software installation and management, and a detailed description of all XI 1 features and services. This information is contained in two documents:

- ***XII software management*** (553-3001-300)
- ***XII features and services*** (553-3001-305)

**See the *SL-I XII input/output guide*** (553-300140) for a description of all administration programs, maintenance programs, and system messages.



## Related documentiori

The following documents contain information that may be of value during the site planning and preparation process.

- 1987. "Maintenance, Testing and Replacement of Large Storage Batteries." IEEE, Vol. **450**: all pages.
- 1987. "Design and Installation of Large Lead Storage Batteries." IEEE, Vol. 484: all pages.
- **1981, 1982, 1983**. ANSI/IEEE Standard, **Vols. 484, 142, 81**: all pages. (484-1981; 142-1982; 81-1983)
- 1984. Gaseous Hydrogen Systems. **NFPA**, Vol. 50A: all pages.
- 1984. National Electrical Code. NFPA, Vol. 70: all pages.
- 1986. Canadian Electrical Code. Canadian Standards Association, **C22-1-1986**
- Grounding Electrode System  
(NBC Articles: **250-23, 250-26, 250-54, 250-8 1, 250-83, 250-84** and, 250-86)  
(**CEC 10-204, 10-206, 10-504, 10-520, 10-700-710**)
- Grounding Electrode Conductor  
(**NEC Articles: 250-23, 250-26, 250-51, 250-53, 250-9 1, 250-92** and, 250-94)  
(**CEC 10-500, 10-502, 10-804, 10-808, 10-812**)

- Grounded Conductor (i.e., Neutral)  
(NEC Articles: 250-26, 250-50, 250-51, 250-53 and, 250-61)  
(CEC 10-206, 10-900-908, 10-500, 10-502, 10-518)
- Equipment Grounding Conductor (NEC Articles: 250-50, 250-51, 250-53, 250-57, 250-91, 250-32, 250-92 and; 250-95)  
(CEC 10-900-908, 10-500, 10-502, 10-510, 10-804, 10-300, 10-302)
- Main Bonding Jumper (NEC Articles: 250-23, 250-26 and, 250-61)  
(CEC 10-204, 10-206, 10-518, 10-520)
- Grounding Evaluation-Practices and Equipment, ECOS Electronics Corporation, 205 West Harrison Street, Oak Park, IL 60304
- Full of Potential, James G Biddle Co. Plymouth Meeting, PA 19462.
- Protection of Electronic Computer/Data Processing Equipment -NFPA 75
- MIL-Handbook • 4 19 (raised floor installation requirements)
- “Network Equipment Building Systems Generic Equipment Requirements” specification TR-EOP-000063, Bellcore.
- OSHA • Occupational Safety and Health Administration Standards (29 CFR 1910)
- Recommended Practice on Static Electricity • NFPA 77
- Soares Grounding Electrical Distribution Systems for Safety
- Uniform Building Code 1982
- Local building codes

Note: If a conflict arises between a code included in this document and a local or national code, follow the local or national code.

---

# Contents

---

<b>Planning activities</b>	<b>1</b>
The installation outline	1
The Milestone chart	4
<hr/>	
<b>Researching the requirements</b>	<b>7</b>
General requirements	7
The equipment room environment	8
Environmental factors	11
Temperature and humidity	11
Static electricity	11
Vibration	11
Electromagnetic Interference (EMI)	12
Dust	12
Lighting	13
Earthquake bracing	13
Structural	13
Air conditioning requirements	13
SL-1 system power options	16
DC-powered SL-1 systems	17
AC-powered SL-1 systems	18
Commercial AC power source	18
Input power specifications	19
Commercial power conditioning	20
Grounding	20
Commercial power and grounding requirements	21
Building ground requirements	21
Isolated ground topology	22
Non-isolated ground topology	22
Grounding guidelines	22

---

AC service panel	23
Dedicated versus shared power	23
Auxiliary power requirements	32
Isolated service receptacles	<b>32</b>
Non-isolated service receptacles	32
Power Fail Transfer Unit (PFTU) powering	32
Cabling	33
Cable types	33
Twisted-pair telephone cables	33
25-Pair MDF cables	33
Twisted-pair shielded cables	33
Interface (I/O) cables	34
UEM cable routing	34
Network to PE cabling	34
Power and ground cables	34
Cable access requirements	35
Fire protection and safety precautions	35
Fire protection and prevention	<b>35</b>
Recommended fire extinguishing systems	36
Security precautions and safeguards	37
Safety procedures and training	37
Occupational noise exposure	37
<hr/>	
<b>Planning the site</b>	<b>39 ---</b>
Selecting a site	39
Space	39
Location	39
Power and grounding	39
Structural integrity	39
Developing the site	40
The equipment room	40
Primary storage	40
Secondary storage	41
Maintenance/Technician area	41
Equipment room accessories	41
The floor plan	42
Floor loading estimates	47
The building cable plan	48
Wire routing	51
Floors	51

---

Ceilings	51
Walls	5-1
Between floors	51
Electromagnetic Interference (EMI)	52
Termination points	52
Distribution frames	52

---

<b>Preparing for delivery</b>	<b>55</b>
Considerations	55
Equipment handling precautions	57

---

<b>Preparing for installation</b>	<b>59</b>
Work orders	59
Equipment room floor plans	60
Cabling plan	61
The installation plan	62
Manuals	62
Preinstallation inspections	62
Equipment room inspections	63
General inspections	64
Reserve power inspections	64





---

# Planning activities

---

## The installation outline

Since installations differ from site to site, no single overall schedule of predelivery activity will apply in all cases. In each instance, prepare a detailed plan when the site has been selected and the equipment ordered. Use Table 1, "Outline for installation planning, " as a guide for making a detailed checklist. Use Table 2 for listing the activities that are involved in site preparation.

**Table 1**  
**Outline for installation planning**

<b>Items</b>	<b>Procedures</b>
<b>Research</b>	<p>Read the requirements identified in this document.</p> <p>Establish equipment environment, air conditioning requirements, floor loading requirements, and other requirements listed in this section.</p>
<b>Select a site</b>	<p>Check space, location, power and grounding, and delivery issues.</p>
<b>Develop the site</b>	<p>Produce a detailed checklist. Use this outline as a guide.</p>
<b>Prepare for delivery</b>	<p>Prepare equipment room environment and delivery route.</p> <p>Ensure safety conditions.</p> <p>Establish fire prevention.</p>
<b>Prepare for installation</b>	<p>Obtain work orders, equipment room floor plans, cabling plans, manuals, installation plans, preinstallation inspections, and delivery equipment.</p>

**Table 2**  
**Site planning activities**

<b>Activities</b>
<p><b>P</b>erform detailed site survey. Determine if building wire needs <b>v</b>erification and gather preliminary customer data.</p>
<p>Hold contract review meeting.</p>
<p>Prepare project <b>p</b>lan.</p>
<p>Hold customer meeting to discuss project plan and division of responsibilities.</p>
<p>Hold Construction Phase site survey to prioriize site development tasks.</p>
<p>Identify environmental, space, power and grounding requirements <b>a</b>nd prepare site accordingly.</p>
<p>Gather customer data.</p>
<p>Perform site inspections to ensure site is ready for installation.</p>
<p>Plan customer user training.</p>
<p>Note: In all the activities above, the Northern Telecom distributor is generally responsible to ensure that these activities have been implemented.</p>

### The Milestone chart

Planning and monitoring site preparation **activities** is easier when you use a Milestone chart. The Milestone chart is a site planning schedule. It shows the sequence of activities necessary to complete a job and will be different with each site. Depending on the complexity of the site, the chart may be more detailed with scheduled due dates for each activity group.

When preparing your Milestone chart, consider not only the individual operations, but **the** overall installation schedule. A Milestone chart may show the necessary operations in order and may assign a start date and end date for each.

Remember to obtain the appropriate sign-offs when the site is ready for delivery and installation of the equipment. Sign-offs may include regulatory items such as electrical and air conditioning inspections and the approval of the cable plan.

Table 3 lists typical activities that should be included in the Milestone chart. Your chart may differ from this one.

The first Milestone prior to delivery should be used to prepare specifications and drawings, request bids, order equipment related to the site preparation, and begin renovations or construction of the equipment room.



**Table 3**  
**Milestone chart**

1	<p>Select the site.</p> <p>Plan the equipment room layout.</p> <p>Plan power and grounding, reserve and/or battery requirements.</p> <p>Plan cable requirements.</p> <p>Plan and start renovations to implement equipment room layout.</p>
2	<p>Continue site construction and renovation tasks.</p> <p>Install power, grounding, reserve power, air conditioning, and heating.</p> <p>Install special rigging such as overhead cable racks and distribution frame equipment as required.</p> <p>Test site wiring to ensure minimum requirements are met.</p>
3	<p>Complete construction and ensure power and grounding are in place.</p> <p>Test air conditioning and heating systems.</p> <p>Complete final equipment room inspection identifying and resolving any delivery constraints.</p> <p>Make equipment delivery arrangements.</p>
<p>Note: The Milestone chart shown is only an example of the activities <b>recommended</b> for site preparation. Depending on the complexity of the site, <b>the chart</b> will be more detailed with scheduled due dates (milestones) for each <b>activity</b> group.</p>	



---

## Researching the requirements

---

Knowing the requirements for system installation saves valuable time and energy when the time comes for system delivery. The first step in planning a site, then, is researching those requirements. The purpose of this section is to **define** the general requirements necessary to plan and develop the site before system installation.

### General requirements

The following general requirements must be considered (in addition to local and national building and electrical codes) when planning the installation of an SL-1 system:

- Equipment room environment (including preliminary floor plan and system layout)
- Power and grounding requirements
- Cabling requirements (including guidelines for ordering correct cable lengths)
- Fire protection (including location of sprinkler heads) and safety precautions



## The equipment room environment

The environment that the SL-1 operates in and that spare parts are **stored in** can influence system performance and reliability. When establishing the equipment environment, control over these factors is necessary:

- temperature and humidity
- static electricity
- vibration
- electromagnetic/radio frequency interference
- dust
- lighting
- floor/walls/ceiling materials

Note: The location must provide sufficient cooling for efficient operation of the equipment and a suitable operating environment for the system.



### CAUTION

#### Heat sources near equipment

Equipment exposure to absolute limits should not exceed 72 hours. Since temperature readings are taken at the front of the equipment and above the floor, no heat sources (such as floor heaters) should be placed near the equipment.

Table 4 shows the SC-1 operating **environment**:

**Table 4**  
**SL-1 operating environment**

<b>Equipment</b>	<b>Temperature and humidity considerations</b>
<b>Terminals (sets)</b>	Absolute <b>0-50° C (32-122° F),</b> RH <b>20-80%</b> , non-condensing
<b>SL-1</b>	
<b>Recommended</b>	Absolute
15-30° C (59-86° F)	<b>10-45° C (50-113° F)</b>
RH 20 to 55%, non-condensing	RH 20 to 80%, non-condensing temperature change less than 1 0° C (18° F) per hour
<b>Auxiliary (terminals and printers, for example)</b>	Refer to specific NTP document or manufacturer's guidelines.
 <b>Note 1:</b> Temperature readings should be taken 30 inches (760mm) from the front of the system.	
 <b>Note 2:</b> Frequent and extended operation above the recommended temperature limits may degrade system reliability.	
 <b>Note 3:</b> The CE/PE power supply, MDU, and FDU units must be located in the lower two module positions when the system is operated above the recommended temperature limits.	

In addition to proper operating **temperatures** and humidity considerations, the SL-1 should be stored and/or transported under the following specifications:

**Table 5**  
**SL-1 storage/transportation environment**

<b>Equipment</b>	<b>Temperature and humidity considerations</b>
<b>Terminals (sets)</b>	Absolute <b>-50 to 70° C (-58 to 158° F)</b> RH <b>5-95%</b> , non-condensing
<b>SL-1</b>	
Recommended	Absolute
<b>1 5-30° C (59-86° F)</b>	<b>-20 to 60° C (-4 to 140° F)</b>
RH 20 to <b>80%</b> , non-condensing	RH 5 to <b>95%</b> , non-condensing temperature change less than <b>20° C (36° F)</b> per hour
<b>Auxiliary</b>	Refer to appropriate Northern Telecom Publication
<b>Floppy diskettes</b>	Absolute <b>4-53° C (39-i 27° F)</b> RH <b>8-90%</b> , non-condensing temperature change less than <b>20° C (36° F)</b> per hour



---

## Environmental factors

### Temperature and humidity

High temperatures tend to increase the rate of deterioration of most materials. Temperature fluctuations can cause temporary or permanent changes to equipment which can affect the grade of service. Low humidity conditions can increase the build up of static electricity, while high humidity can have an adverse effect on the performance of disks, tapes, and printers.

### Static electricity

Microelectronic circuits are extremely sensitive to static discharge. Static discharge can cause permanent damage to any circuitry and/or interruptions in system operation and the loss of data. Static electricity could be the result of physical vibration, friction, and separation of materials. The most common collectors of static electricity are people. Other common causes of static electricity build-up are low humidity, certain types of carpeting, the use of wax on equipment room floors, and plastic-soled shoes.

Plastic-soled shoes, for example, are noted for generating large amounts of static electricity. The insulative nature of the shoes, and certain flooring materials and levels of humidity, can cause the wearer to accumulate and carry body charges in excess of 15 kV.

Note: IEEE Standard 142-1982 recommends that flooring resistance should be more than 25,000  $\Omega$  and less than 1 million megohms, measured by two electrodes 3 feet (0.91 m) apart on the floor. Each electrode must weigh 5 lb (2.2 kg) and have a dry flat contact area of 2.5 inches (63.5 mm) in diameter.

Some products that prevent static discharge include sprays, anti-static mats, and wrist straps.

### Vibration

Vibration can cause slow deterioration of mechanical parts and, where severe, can cause serious disk errors. Structure-borne vibration and consequent noise transferred to the equipment room should be avoided. Raised floors should have extra support jacks at strategic places to prevent the transmission of vibration.

Vibration in the office environment should be limited to a frequency range of **0.5-200** Hz and a G-force magnitude of 0.1 G (according to the **Bellcore** Network Equipment Building Systems Generic Equipment Requirements specification TR-EOP-000063).

### Electromagnetic Interference (EMI)

Sources of EMI located close to the equipment may have an effect on system operation. Common EMI sources known to disturb system operation are:

- thunderstorms, static electricity, high-voltage power lines
- radar, broadcast stations, mobile communications
- power tools, appliances (vacuum cleaners ), and office business machines (copiers)
- industrial machines and ultrasonic cleaners
- vehicle ignition, arc welders, and dielectric heaters
- dimmer switches

*Note:* The SL- 1 system meets the United States Federal Communications Commission (FCC) Rules, Part 15, Subpart J and Canadian Standards Association (CSA) **C108.8** for radio frequency interference and/or electromagnetic interference (**RFI/EMI**) radiation.

### Dust

Average dust density for an office environment must be Zone 4 (**0.00014g/m<sup>3</sup>**) or better. False ceilings and tiled floors help maintain dust density requirements. Accumulation of dust and dirt can:

- scratch gold contacts on printed circuit packs, causing intermittent failures
- have conductive contents, increasing component susceptibility to damage by static electricity
- cause components to operate at higher temperatures
- be detrimental to system reliability and performance and increase maintenance and warranty costs

## Lighting

Lighting illumination of 50-75 footcandles measured 30 inches (76 cm) above the equipment room floor is recommended. Lighting must not be powered from the equipment room power panel. For large system installations, provisions for emergency lighting in the equipment room should be considered. Direct sunlight in the equipment room should be avoided to prevent the malfunctioning of devices which employ light sensors (magnetic tape and disk units).

## Earthquake bracing

In some equipment room environments, the need for earthquake bracing should be considered or may be required. See the ***System installation procedures*** (553-3001-210) for detailed instructions on how to install proper earthquake bracing.

## Structural

Floors should either be sealed concrete, vinyl, or mastic tile and should meet floor loading requirements: avoid using sprayed ceilings or walls.

## Air conditioning requirements

The air conditioning provided must be capable of handling the heat produced by the SL-1 system, as well as the additional heat produced by equipment room personnel, lighting, and the heat input of external walls, windows, **floors** and ceilings enclosing the room. A stable ambient operating temperature of approximately **22° C (72° F)** is generally recommended. The temperature differential in the equipment room should not exceed **±3.0° C (± 5° F)**.

Note: For systems using reserve power batteries, consult the manufacturer's specifications for recommended operating temperatures.

Heat dissipation of a system is estimated in **BTU/hr**. The amount of air conditioning required can be estimated at a rate of one U.S. ton of refrigeration for every 12,000 **BTU/hr** of heat generated by the equipment and equipment room personnel, plus one ton for each 500 square feet of floor space. Each person in the equipment room generates 600 **BTU/hr**.

These guidelines should be used along with the following tables when estimating air conditioning requirements. Exact requirements should be determined by a qualified air conditioning engineer.



**CAUTION**

**Proper air conditioning standards**

Digital systems require constant power regardless of the level of system activity (idle or busy) and therefore generate heat continuously. Ensure that proper air conditioning standards are met at all times.

Table 6 shows the maximum power dissipation in the form of heat for each SL-1 Module. These figures apply to both AC- and DC-powered systems. The power figures listed here do not necessarily correspond to total input power, since some of the power - especially for peripheral equipment - is distributed out to the sets and is not dissipated within the system.

Table 7 shows the maximum heat dissipation for some of the external DC power equipment supplied by Northern Telecom.

**Table 6**  
**SL-1 system heat dissipation**

Module	Heat dissipation	
	Watts	BTU/hr
NT8D11 Common/Peripheral Equipment	450	1530
NT6D39 CPU/Network	400	1360
NT8D34 CPU	300	1020

-continued-

**Table 6 continued**  
**SL-1 system heat dissipation**

Module	Heat dissipation	
	Watts	BTU/hr
NT8D35 Network	300	1020
NT8D13 Peripheral Equipment	300	1020
NT8D37 Intelligent Peripheral Equipment	425	1450
NT8D47 Remote Peripheral Equipment	300	1020
NT8D36 InterGroup	0	0

Note: Thermal load (BTU/hr) = Total power dissipation (Watts) x 3.4

**Table 7**  
**External power equipment heat dissipation**

Equipment	Heat dissipation	
	Watts	BTU/hr
QRF12B 30A Rectifier	200	680
NT5C03 50A Rectifier	290	990

Note: Thermal load (BTU/hr) = Total power dissipation (Watts) x 3.4



## Sk-I system power options

The SL-1 system is available in both AC and DC versions where DC power is connected to the commercial power panel by means of extended power rectifiers or power plants, and the AC power is connected directly to the commercial power panel. If an Uninterruptable Power Supply (UPS) is used in conjunction with the AC SL-1 system, the UPS connects to the commercial AC source and the SL-1 system columns are connected to the UPS. The SL-1 is available with the following power options:

- DC-powered systems
- DC power with reserve power (backup)
- AC-powered systems
- AC power with reserve power (backup)

For AC-powered SL-1 systems each column of equipment should have an AC receptacle provided within 10 feet of the column's pedestal. If the system is equipped with a UPS, the AC source should feed to the location of the UPS (see the UPS vendor's specifications). The UPS will then feed the equipment columns.

For DC-powered SL-1 systems the commercial source feeds to a centralized rectifier rack or to a centralized power plant. The rectifier rack/power plant provides -48 V dc to the system.

In either case the power connections to the SL- 1 system can be provided through the floor or by means of overhead racks.

## DC-powered SL-1 systems

DC-powered SL-1 systems, which use direct current UEM power converters, operate at a nominal -48V dc. UEMs in a column are fed DC power from the pedestal Power Distribution Unit (PDU). The pedestal is powered from an external DC power plant

The NT7D12AA rectifier rack contains up to three NT6D52AA rectifiers which operate from a nominal 120/240 V ac at 30 Amps. This configuration is typically used for Options 21, 51, and 61. The QCA13 power plant contains up to four NT5C03BJ rectifiers which operate from a nominal 208V/230 V ac at 23/21 Amps. This configuration is typically used for Option 71.

A typical column operating at -48 V dc using four UEMs will draw up to 60 Amps depending on the configuration.

Commercial power requirements for the DC power plant depend on the system size and power plant configuration. All SL-1 systems can be powered by customer-supplied or Northern Telecom-supplied -48 V dc. Refer to **Power engineering** (553-3001-152).

Reserve Power-DC-powered systems that require reserve power use battery backup. For battery requirements, refer to **Power engineering** (553-3001-152).

## AC-powered SL-1 systems-

Power converters in SL-1 systems, which use alternating current, operate at a nominal **208/240** V ac. A typical system operating from 208 V using four **UEMs** will draw 15-25 Amps depending on the configuration. These are fed from a central point in the pedestal; access to these connections is provided and should be used to **confirm** that the **line** voltage is within the required range.

Reserve power-AC-powered systems with reserve power use an Uninterruptable Power Supply (UPS). The UPS must be installed according to the vendor's specifications. The UPS installation should be inspected and signed off prior to starting the SL-1 system installation.

## Commercial AC power source

Although some smaller DC systems may use rectifiers that can be configured for 120 volts, Northern **Telecom** recommends that all systems use single-phase 240 volt or 208 volt single phase which is **208Y** derived:

## Input power specifications

The following tables provide input system power specifications as required for **AC** power:

**Table 8**  
Input power specifications

Input	Minimum	Nominal	Maximum
Voltage (VAC) at pedestal	180	208/240	250
Frequency (Hz)	47	50/60	63
<b>Transient tolerance (See note)</b>			
	Amplitude	Duration	
Surges	<b>288 V ac</b>	<b>8.34 mS to 50 mS</b>	
	<b>276 V ac</b>	<b>50 mS to 500 mS</b>	
Sags	146Vac	<b>8.34 mS to 50 mS</b>	
	166Vac	<b>50 mS to 500 mS</b>	
Spikes	815 V pk	< <b>4.17 mS</b>	
	<b>815 V pk to 408 V pk</b>	4.17 to 8.3 mS	
Notches	to 0V	< <b>4.17 mS</b>	
	<b>0 V to 206 V</b>	4.17 mS to 8.3 mS	
<p>Note: These values are taken from the National Electric Code and various <b>Telco</b> specifications. All transients are applied at the peak of the AC waveform.</p>			

## Commercial power conditioning

If the quality of the commercial power source continuously meets the SL-1 system requirements listed in this section, a power conditioner is not required, however, where the commercial power is of poor quality and cannot consistently meet the SL-1 system requirements, a power conditioner may provide some improvement.

*Note:* When using power conditioning equipment, simply install the equipment in series with the commercial power feed. Do not modify the SL-1 system grounding scheme.

## Grounding

Essential to trouble-free system operation and the safety of personnel is the employment of proper grounding. The SL-1 system has several different grounds and signal returns that are generally referred to as grounds: logic return (for DC systems), AC “green wire” ground (in AC systems), and the personal hazard equipment ground.

The SL-1 system does not, by design, need an AC isolated ground (IG) system (though this may be required by local codes), but it does need a single point ground system. This means **that** each of the various grounds from each of the columns should terminate at a single connection point before attaching to the actual ground reference at the main AC panel or transformer. The single point ground may be implemented either by use of the isolated ground bus in the AC panel, or by a separate logic return equalizing bus for battery returns and logic returns where a non-isolated AC system is used.

The SL-1 system power must originate from the supply service (main AC panel or transformer) where the ground conductor and the neutral conductor connect and are referenced to the main building ground (**MGM**). Cold water pipes and ground rods should only be used to improve the ground reference of the building’s main service panel. Do not use the MGM as the ground reference for the SL- 1 system.

The DC resistance of the system ground conductor, which runs from the SL-1 to the main building ground, should be as close to zero as possible with the maximum total resistance on all runs within the building not to exceed 0.5 ohms.

Failure to follow **the grounding** procedures may result in an installation that is:

- unsafe for personnel working on or using the equipment
- not protected **from** lightning or power transients
- subject to service interruptions
- subject to degraded system performance

## Commercial power and grounding requirements

The commercial power source refers to the main AC utility power feed, for either AC-powered or DC-powered systems. For AC systems, this power is wired directly to the system. For DC systems, this power source connects to the rectifiers which convert to -48 V dc for distribution to the system.

In North America, the power supplied can be either **208Y** or 240 V ac nominal. Three phase is not required by single power feeds from alternate phases is normal practice where three phase power is available. Refer to Table 8 for the exact voltage range.

## Building ground requirements

Although the SL- 1 system (by design) does not require an isolated AC ground system, the NEC does. For this reason Northern Telecom --- recommends the use of an isolated AC ground system. Non-isolated ground systems are acceptable only where not required by a national code.

This system does not need an isolated AC ground system, but it does need a single point ground system. Single point ground may be implemented either by the use of an Isolated Ground (IG) bus in the AC panel to terminate all AC grounds and other ground reference conductors, or by a separate logic return equalizer (**LRE**) ground bus for system ground and logic returns where a non-isolated AC system is used.

**Note:** Where required, Northern Telecom will provide an LRE with each system delivery. Multi-column systems require the use of an **LRE**.

### Isolated ground topology

A dedicated Isolated Ground (**IG**) bus bar is required with this method. This IG bus is located in the AC panel and serves as the ground window. It is used for all AC (green wire) grounds as well as logic returns. It also accommodates a conductor which references to the (+) battery bus in a DC system. An alternate form of this isolated topology is to use one or more isolated equalizing bars external to the AC panel but which connects to ground exclusively by means of the AC IG bus.

Isolated orange outlets are required (as per NEC 250-74 Exception 4). Grounding conductors shall be routed with the phase conductors (Article 300-20). All ground wiring-for IG receptacles are to be terminated on the dedicated IG bus per applicable codes (complies with NEC 384-27).

### Non-isolated ground topology

In a non-isolated system the AC equipment ground (ACEG) connects to the metal panel, and the associated conduit may also contact various structural metal. This ground alone is not adequate for the SL-1 system, but a dedicated ground conductor which connects to the main building ground is then used for the main ground window to terminate logic returns and reference the (+) battery bus. Frame grounds will connect to the ACEG.

## Grounding guidelines

The following must be observed to implement the single-point ground:

- All ground conductors must be identified in accordance with local codes and terminated in a manner that is permanent, resulting in low impedance connections.
- Terminations should be accessible for inspection and maintenance during the life of the installation.
- All grounding conductors must be continuous with no splices or junctions and tagged, **“Do not remove or disconnect.”**  
They should also be insulated against contact with foreign grounds.
- Grounding conductors must be no-load, noncurrent carrying cables under normal operating conditions.

- In a steel-framed building, the SL-1 ground interface must have a connecting reference to the building steel on the same floor on which it resides (or within one floor).

**Note:** Northern Telecom does not recommend the use of building steel as part of the SL-1 ground system.

Proper wire sizing of the System Ground Reference conductor ensures compliance with this requirement provided the building ground has been properly installed as per NEC rules and regulations and the associated CEC regulations.

Using an Isolated Ground bus is often a lower cost method but may not be allowed by all telcos and may be prohibited by local ordinances.

Note: All voice and data lines leaving or entering the SL-1 system (which run external to the building) must have fault protectors that connect directly to earth ground. Fault protectors provide **EMI/RFI** protection outside of the SL-1 system.

## AC service panel

### Dedicated versus shared power

Dedicated AC power transformers are preferred; however, a shared transformer or distribution is acceptable.

The following figures identify the differences between dedicated and shared distribution and between isolated and non-isolated grounds:



**Figure 1**  
**Dedicated transformer in isolated ground system**

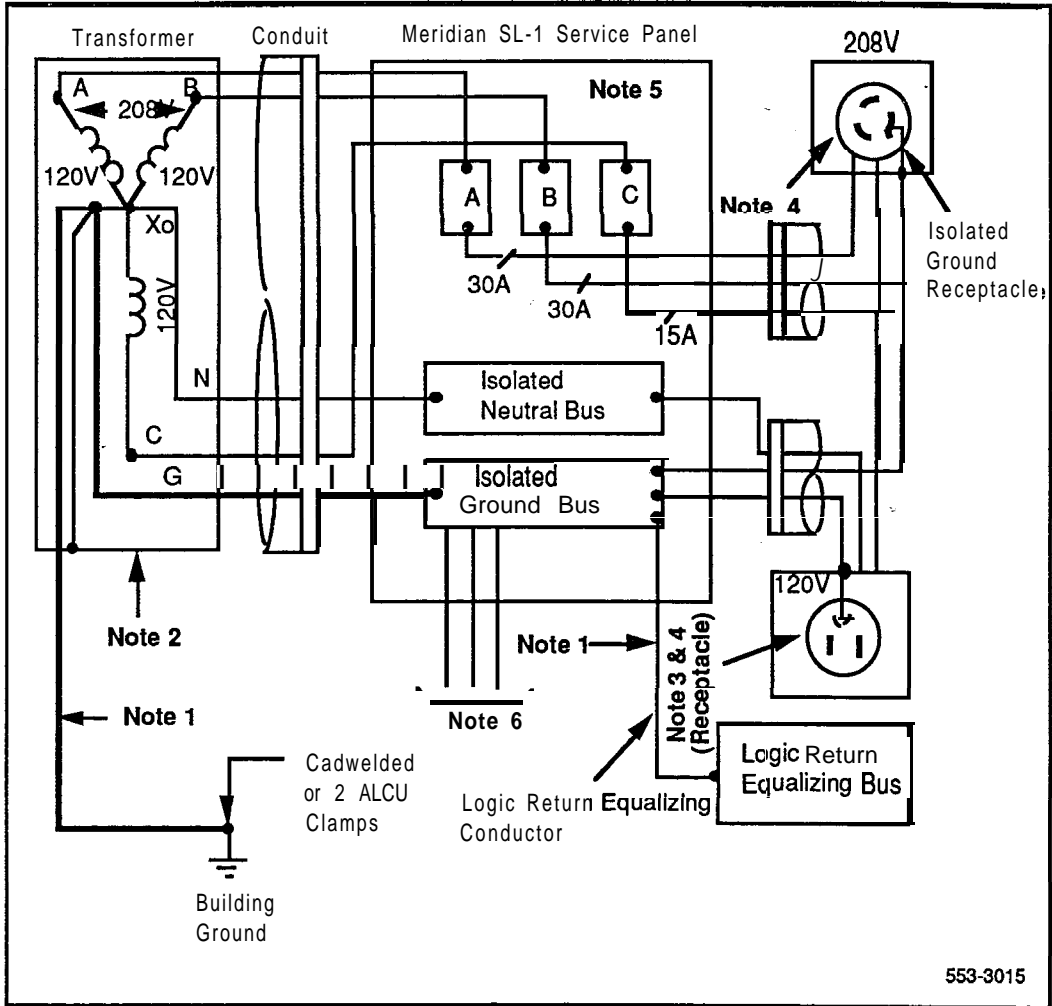

**Notes for Figure 1:**

- 1** Ground conductor should be the same size as the largest conductor run between the transformer and the AC panel.
- 2** Transformer (dedicated for SL-1 and **Telco** Interface Equipment) shall provide a secondary voltage of single phase **120/240** or three phase **208Y/120V** and must have a system ground conductor.
- 3** Receptacles: All 120V service drops in the equipment room must have IG type receptacles. Each circuit must have individual hot, neutral, and ground conductors.
- 4** NEMA numbers for receptacles are:  
208/240 @ 30 A IG-6-30  
120 @ 15 A IG-5-15  
Panel circuit breakers are:  
208V/240V 30A
- 5** A dedicated service panel should be located in the equipment room.
- 6** If the service panel has sufficient terminating points on the isolated ground bus, the logic return equalizer may not be required.

**Figure 2**  
Dedicated transformer in non-isolated ground system

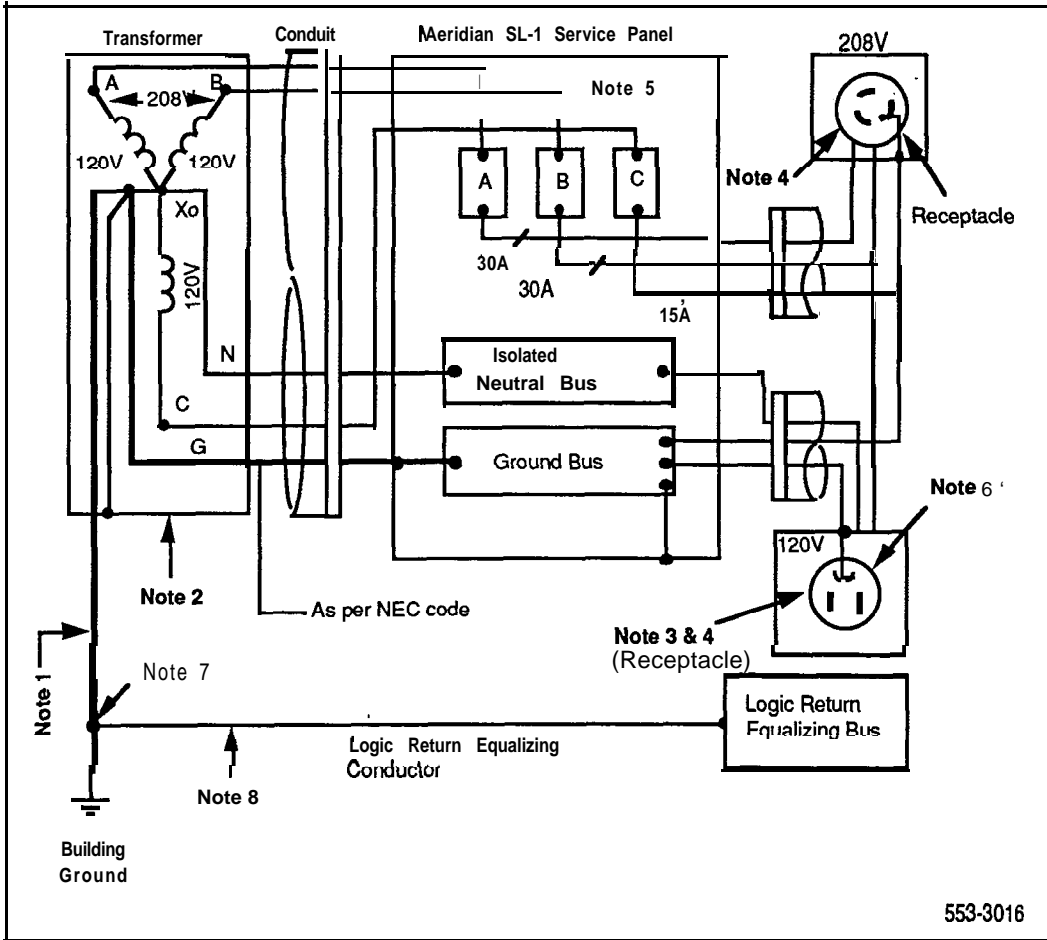

*Notes for Figure 2:*

- 1 Ground conductor should be the same size as the largest conductor run between the transformer and the AC panel.
- 2 Transformer (dedicated for SL-1 and **Telco** Interface Equipment) shall provide a secondary voltage of single phase **120/240** or three phase **208Y/120V** and must have a system ground conductor.
- 3 Receptacles: Each circuit must have individual hot, neutral, and ground conductors.
- 4 **NEMA** numbers for receptacles are:  
208/240 @ 30 A L6-30  
120 @ 15 A 5-15  
Panel circuit breakers are:  
208V/240V 30A
- 5 A dedicated service panel should be located in the equipment room.
- 6 Auxiliary equipment using an RS-232 interface will, if such equipment is too remote to be **powered** from the SL-1 **service** panel, require a modem or fiber link to provide ground isolation.
- 7 Connection to the building ground source should be made at the same physical location as the transformer grounding conductor. If the LRE is connected to a building ground point other than the transformer ground point, a bonding jumper must be installed between the two points.
- 8 Two approved fastening devices or cadwelded devices should be used here.

**Figure 3**  
**Shared AC distribution in an isolated ground system**

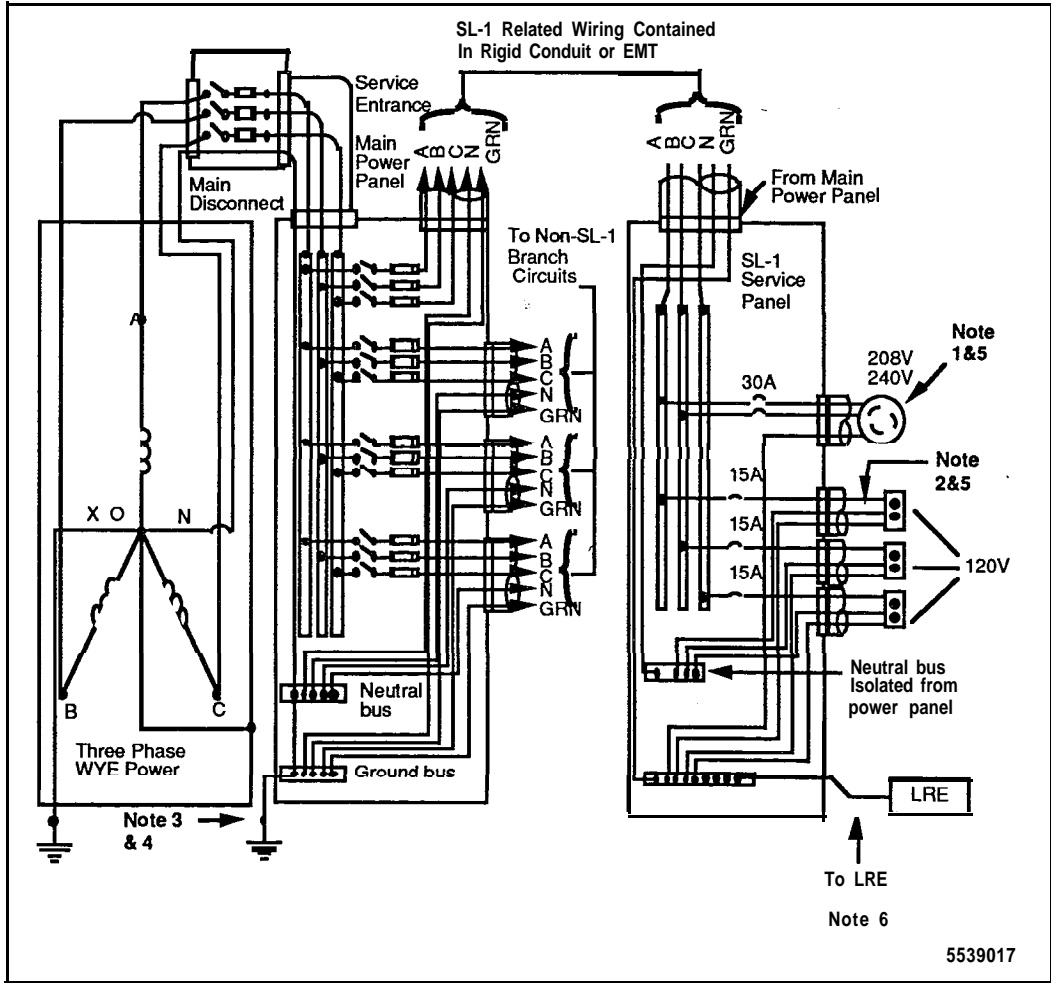

**Notes for Figure 3:**

- 1** An isolated ground receptacle must be used for systems with isolated ground.
- 2** An isolated ground receptacle with individual hot neutral and ground conductors must be used for systems with isolated ground.
- 3** An alternate earthing electrode, if required, must be installed in a minimum of 6 ft. (1.8m) from the building earth reference.
- 4** Connections to the building earth reference must be either cadwelded or provided with two ALCU clamps.
- 5** NEMA numbers for IG ground receptacles are:
  - 208/240 @ 20 A IG-L6-20
  - 208/240 @ 30 A IG-L6-30
  - 120 @ 15 A IG-5-15Panel circuit breakers are:
  - 208V 30A
  - 240V 30A
- 6** Connection to the building ground source should be made at the same physical location as the transformer grounding conductor. If the LRE is connected to a building ground point other than the transformer ground point, a bonding jumper must be installed between the two points.

Figure 4  
Shared AC distribution in a non-isolated ground system

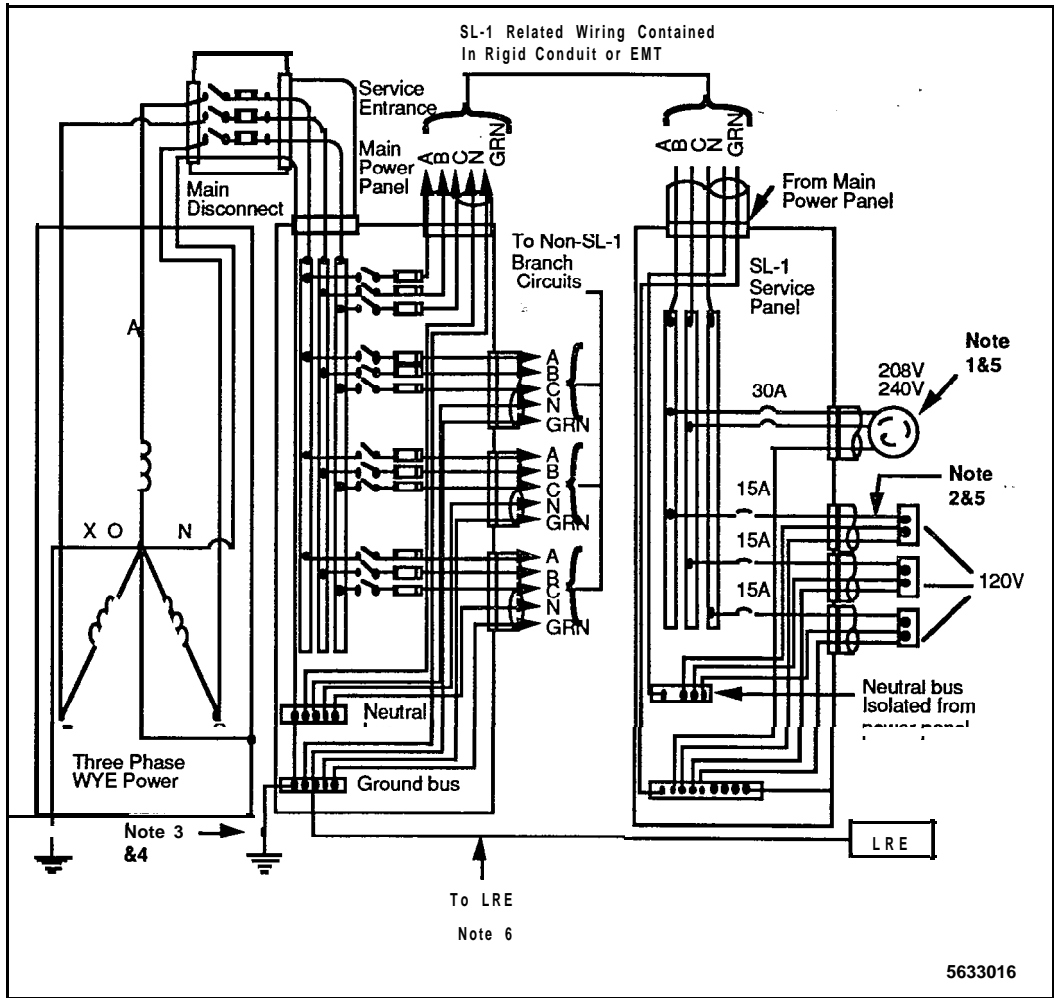

*Notes for Figure 4:*

- 1 An isolated ground receptacle must be used for systems with isolated ground.
- 2 An isolated ground receptacle with individual hot neutral and ground conductors must be **used** for systems **with** isolated ground.
- 3 An alternate earthing electrode, if required, must be installed in a minimum of 6 ft. (1.8m) from the building earth reference.
- 4 Connections to the building earth reference must be either cadwelded or provided with two ALCU clamps.
- 5 NEMA numbers for IG ground receptacles are:  
208/240 @ 30 AIG-L6-30  
120 @ 15 A IG-5-15  
Panel circuit breakers are:  
208V/240V 30A
- 6 Connection of the LRE to the building ground source should be made at the same physical location as the transformer grounding conductor. If the LRE is connected to a building ground point other than the transformer ground point, a bonding jumper must be installed between the two points.



## Auxiliary power requirements

Integrated terminals, printers, modems, and data units require local power. Power for devices located in the equipment room must meet the following criteria:

- wired and fused independently of all other receptacles
- tagged at the power panel to prevent unauthorized interruption of power
- not controlled by a switch
- referenced to the same building interface point on the building system ground as the SL-1 AC panel ground

### Isolated service receptacles

For isolated ground systems, the auxiliary power receptacles used should be **120V, 60Hz, 15A**, individually fused, isolated ground circuits terminating on NEMA non-locking type IG 5-15 such as Hubbell, Cat. No. **IG-5262, 2-Pole, 3-Wire**, orange duplex receptacles. A green conductor must be used for extending the safety ground and must be wired according to the isolated ground specifications.

*Note:* This requirement is based on safety concerns and exceeds NRC/CRC requirements.

### Non-isolated service receptacles

For non-isolated ground systems, the auxiliary power receptacles used should be **120V, 60Hz, 15A**, individually fused circuits terminating on NEMA non-locking type 5-15.

In non-isolated ground systems auxiliary equipment which connects to the SL-1 system should be isolated through the use of fiber optic signal cables such as RS-232-C. Failure to provide this isolation will defeat the single point ground.

### Power Fail Transfer Unit (PFTU) powering

The **PFTU**, when used with AC systems, operates with a separate 120 V ac to 48 V dc power supply. If the AC system is not backed-up (for example, when no UPS is present), the **PFTU** power supply requires a separate and dedicated auxiliary power outlet. Power to the **PFTU** is terminated when the system power goes down and vice versa.

## Cabling

This section identifies the various cabling used in the SL-1 system and provides some guidelines for cabling. Equipment placement in relation to cable lengths should be considered and planned for. Depending on your system and future expansion (of PE modules, for example), the cables you choose must be the right length.

### Cable types

All cables must be designated (tagged) at both ends. The SL-1 uses at least five types of wiring:

- Twisted-Pair Telephone Cables
- 25-Pair MDF Cables
- Twisted-Pair Shielded and Non-Shielded Cables
- Interface (I/O) Cables
- Power and Ground Cables

### Twisted-pair telephone cables

These cables carry analog voice and digitized voice/data information between distribution frames and devices located throughout the office. They run from cross-connect panels to jacks (8-pin modular) located within 8 feet (2.4 m) of each peripheral device.

### 25-Pair MDF cables

These cables carry voice and data information between the SL-1 UEMs and the distribution frame. When the cables are run from the UEM to the distribution frame, one end of the cable must be equipped with a 25-pair female connector which terminates on the cabinet I/O panel.

### Twisted-pair shielded cables

These cables are used to interconnect the trip power monitoring connections between power interface units and the main distributing frame. Typically, a 16 AWG, stranded (Belden type 8408-2 conductor or equivalent) type shielded cable is used for trip connections. All other connections are serviced by non-shielded, 16 AWG stranded cable.

### **Interface (I/O) cables**

I/O cables are typically **25-conductor** flat-ribbon or round cables interfaced through RS-232-C connectors. These cables are used to connect data units to printers, host computers, and modems.

### **UEM cable routing**

Cables may be routed internally in the UEM horizontally in front and at the rear of the card cage, vertically on the right side only and vertically through square holes near the rear of the DEM. Cables may be routed externally in the back of and on the left and right side of the UEM between the **EMI/RFI** I/O panel and the rear cover. The cables may be routed in these channels up to the top of the column or down to the floor through the pedestal.

Note: Routing cables on the inside of a UEM from the front to the back on the left or Power Supply side is not recommended. This is because of the limited access in routing the cables and of the effects of **EMI/RFI** noise generated in this area to signals in the cables.

### **Network to PE cabling**

IPE cabling from Network to PE originates from the faceplate of the Superloop Network card and extends to the backplane connectors on the Controller card of the IPE Module.

PE cabling originates from the faceplate of the Network card to the faceplate of the Dual Loop Buffer.

### **Power and ground cables**

For AC-powered systems, a 9-foot, three-conductor line cord is normally supplied except in areas where conduit will be required. For DC-powered systems, wiring is generally done through conduit.

## Cable access requirements

The customer is responsible for supplying all access for station, feeder, and riser cabling including where necessary:

- conduit
- floor boring
- boring all major walls on a particular floor
- access into hung ceilings, including removal and replacement of ceiling tiles

## Fire protection and safety precautions

### Fire protection and prevention

Building, fire, and safety codes establish the degree of protection required for an installation. Additional information is available from the National Fire Protection Association in its publications entitled “Standard for the Protection of Electronic Computer/Data Processing Equipment (NFPA 75) and “National Electrical Code” (NFPA 70).

Properly locating and installing sprinkler heads, **fire** and smoke sensing devices, and other fire extinguishing equipment require expertise. **Local** codes and experts should be consulted during the planning stage, and the recommendations of insurance underwriters and local building authorities should be sought and followed.

Some fire precautions can be implemented during the construction phase of preparation for an installation. Walls enclosing the equipment area should extend from floor to ceiling, and the walls, floor, and dropped ceiling, if any, should be constructed of noncombustible covering. Shatterproof windows and sprinklers outside and above the windows should be installed to prevent the spread of fire from an adjacent building.

If the structural floor is made from combustible materials, it should be covered with a noncombustible covering, and the space between the raised and permanent floors should be cleared of all debris before the system is installed.

Storage areas and the roof or floor above the equipment room should be watertight since water leakage from the floor above could easily damage the equipment below. In addition, ducts and plumbing work for **air-**

conditioning systems should be designed to inhibit the spread of **fire**, heat, and smoke from one part of a building to another. Smoke detectors should also be installed.

Services such as steam, water, and power should be checked **regularly**, and pipes should be inspected for excess condensation, leaks, and corrosion. If power connections are made beneath a raised floor, waterproof electrical receptacles and connectors should be used.

### **Recommended fire extinguishing systems**

In **most cases**, carbon dioxide or water sprinkler systems are to be used. Water sprinklers are generally less expensive than the carbon dioxide kind. Specifically, dry-pipe water sprinklers are strongly recommended since this type will interrupt power to **the** room and open a master valve to fill the overhead sprinklers.

Carbon dioxide systems are also effective in containing a fire, but they quickly exhaust the available oxygen supply. If a carbon dioxide system **is** used, an alarm should sound warning **onsite** personnel of the release of carbon dioxide. For health and safety reasons, employees must be evacuated within 30 seconds of the release.



#### **CAUTION**

##### **Use of other fire extinguishing systems**

Northern Telecom does not recommend the use of **Halon** or any other fire extinguishing system not stated above. Northern Telecom is supported by the Environmental Protection Agency to enforce any restrictions on the use of other **fire** extinguishing systems.

### Security **precautions** and safeguards

Existing practices of building security should be extended and improved to provide adequate protection for the equipment.

Safeguards such as tamperproof **keylock** door controls and electrically taped glass doors and windows can be tied into an alarm system. A monitoring unit using closed-circuit television can also be installed.

Protect critical data such as business records or other information by storing backups well away from the equipment room. A regular updating program is highly recommended.

### Safety procedures and training

Company personnel should be taught how to respond to emergencies. Some companies designate such individuals as security members. Training could include how and when to evacuate personnel and records, to notify the fire department, to shut off all electrical power, and to properly handle fire extinguishers.

In addition to training, temperature and humidity monitoring devices (both visual and audible alarm signals) should be installed in the equipment and storage rooms so that individuals can respond quickly to an emergency.

### Occupational noise exposure

When employees are subjected to noise levels exceeding those listed in 1910.5 of the OSHA Standards, or local standards internationally, administrative and engineering controls should be initiated. If these controls fail to reduce sound levels effectively, protective equipment should be provided. The acoustic noise generated by an SL-1 UEM column should not exceed **60dBA** (decibels "A"-weighted). Depending on the ambient external temperature, the acoustic noise could be as low as 45 **dBA**.



---

## Planning the site

---

Planning the site is an important element to consider when planning the installation of an SL-1. It impacts the installation costs, operation and maintenance and can have an overall effect on system performance.

### Selecting a site

Sites should be selected and evaluated according to the following criteria and the detailed information given in this document:

#### Space

The proposed site should provide adequate space for system unpackaging, system installation, operation, potential expansion, service, storage of supplies, and system operator area (if applicable). It should also provide sufficient cooling for efficient operation of the equipment and a suitable operating environment for the system.

#### Location

The location should be convenient for delivery of equipment and close to related work areas for efficient operation. The location of related equipment (distribution frame and batteries) must be considered when selecting the site.

#### Power and grounding

Sufficient power and proper grounding facilities must be available.

#### Structural integrity

The floor must be strong enough to support anticipated loads, and the ceiling must be able to support overhead cable racks, if applicable.



## Developing the site

After selecting a site, the following items must be considered during site development:

- Space and equipment layout requirements
- Equipment **room** accessories
- Detailed floor plans and loading requirements
- Building cable plans
- System wire routing
- Cable termination points

## The equipment room

Space and equipment layout requirements differ with each installation, depending upon equipment selected and the available physical area. The following categories of required space should be considered when planning site needs:

- Primary storage
- Secondary storage
- Maintenance/Technician area

### Primary storage

The floor area required for an SL-1 depends on the number of columns of **UEMs** ordered, **the** length-to-width ratio of the area, and the location of walls, partitions, windows, and doors. To determine the exact layout required, prepare a detailed floor plan after reading all of the requirements provided in **this** section.

Operating needs determine the location of free-standing peripherals like printers and terminals. Printers and terminals must not exceed the maximum distances defined for their interface circuits. Wall jacks and outlets must be provided for all devices located in the equipment room. Within a system there are certain requirements that must be met when drawing up **the** equipment room floor plan.

Note: Sample floor plans may **vary** from your own depending on your system needs and the size/arrangement of your equipment room.

**Follow** the engineering guidelines as specified in *System engineering* (553-3001-151).

### **Secondary storage**

Provide space for the storage of disks, printer paper, printouts, and daily reports within the equipment area. A secure storage room for spare parts is recommended.

Similar environmental conditions should be maintained for storage and operation areas. If it is not possible to maintain the storage area environment exactly the same as that of the operating equipment, adequate time must be allowed for stored materials to adjust to the equipment room environment before they are used.

### **Maintenance/Technician area**

The maintenance/technician area is used primarily to store tools, test equipment, manuals, spare parts, and as an online work center. The area should have good lighting and convenient access to the equipment. Typical items that would go into a maintenance/technician area are:

- shelf for instruction books
- spare parts storage room
- paper storage area
- locking cabinet or storage area for back up disks
- table or desk
- **printer/VDT** or equivalent device

### **Equipment room accessories**

The following equipment room accessories are recommended:

- Temperature/humidity recorder(s)
- A key or combination with option **keylock** for the switchroom door (electric locks, such as push button access code or card reader, are not recommended unless battery backup or key override is provided)>
- Desk or table, file cabinet, and storage shelves

- Storage cabinets for spare parts, backup tapes or disks, and printer paper

## The floor plan

Since the space requirements and the overall layout of the equipment room can have an effect on the installation, operation, and maintenance of a system, a detailed floor plan should be drawn up for each site.

The floor plan should show the location of utility closets and cross-connect terminals. All cables running from distribution points to the zones should be clearly designated with the zone ID. The zones are typically the termination point of conduits throughout the office. (See Figure 8 “Sample building cable plan” for an illustration of zones.) Within a zone the cables should be identified by their number within the zone.

**Note:** According to the National Fire Code, equipment must be located at least 12 inches from a sprinkler head. If your system has four UEMs and a cable rack, do not place the equipment directly under any sprinkler heads.

Consider the following guidelines when planning the equipment room floor plans:

- a recommended minimum ceiling height of 8 ft (2436mm) or greater
- a minimum distance between equipment aisles of 30 inches (760mm)
- a minimum distance between end of aisle stacks and wall and between rows of 3 ft (914mm)
- location of modems, printers, and terminals
- size and location of reserve power
- size and location of cross-connect terminal
- size and location of maintenance/technician area
- number of rows and future expansion needs (RPE or Meridian Mail, for example). Refer to **System engineering** (553-3001-151) for guidelines on system expansion.

The weight and **dimensions** of the **SL-1** system should also be considered:

**Table 9**  
**Weight and dimensions of an SL-1 system**

<b>Assembly item</b>	<b>Weight empty</b>	<b>Weight full</b>	<b>Size width</b>	<b>Size depth</b>	<b>Size height</b>
Pedestal	40 lbs.	70 lbs.	32 in.	26 in.	10 in.
Top Cap	15 lbs.	15 lbs.	32 in.	22 in.	4 in.
UEM	50 lbs.	130 lbs.	32 in.	22 in.	17 in.
1 Module stack	<b>N/A</b>	215 lbs.	32 in.	26 in.	31 in.
2 Module stack	<b>N/A</b>	345 lbs.	32 in.	26 in.	48 in.
3 Module stack	<b>N/A</b>	475 lbs.	32 in.	26 in.	65 in.
4 Module stack	<b>N/A</b>	605 lbs.	32 in.	26 in.	82 in.

*Note:* Multi-column systems require a three inch spacer between each column for cable routing and to provide EMI shielding.

Figures 5, 6, and 7 show **some** sample equipment room floor plans. These may vary **from** your own.

**Figure 5**  
**SL-1 Option 21 equipment room floor plan**

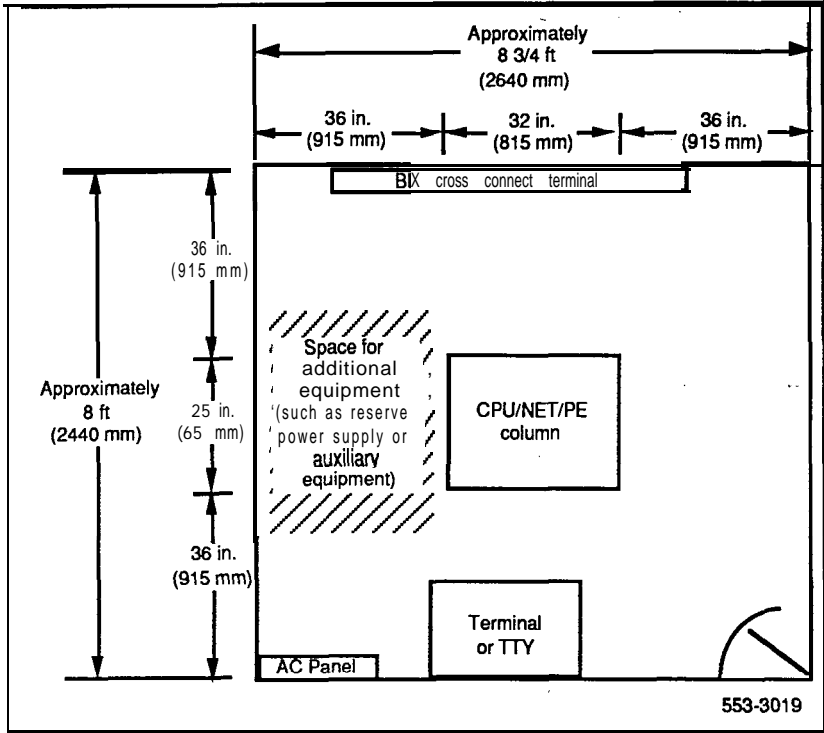

**Note:** This sample floor plan may vary from your own depending on your system needs and the size/arrangement of your equipment room. A template for floor drilling procedures is available. The drawing, (number PO709207), is delivered with the packing instructions.

**Figure 6**  
**SL-1 Options 51 and 61 equipment room floor plan**

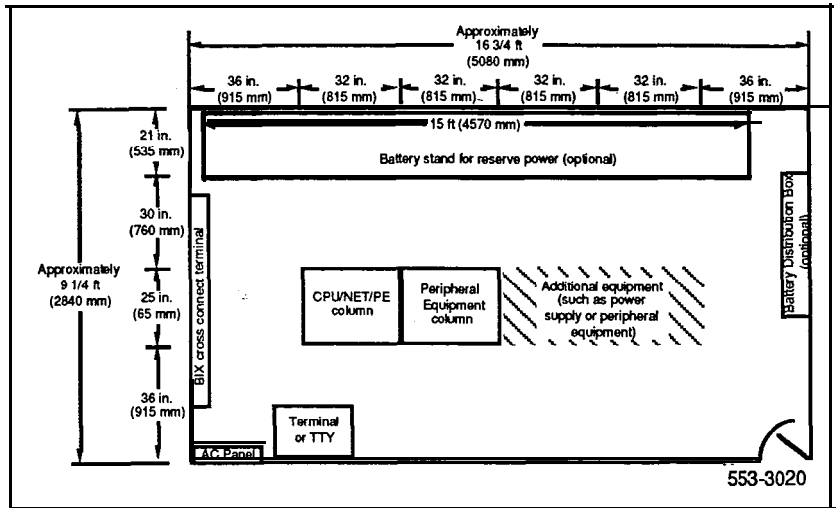

**Note:** This sample floor plan may vary from your own depending on your system needs and the size/arrangement of your equipment room.

Figure 7  
SL-1 Option 71 equipment room floor plan

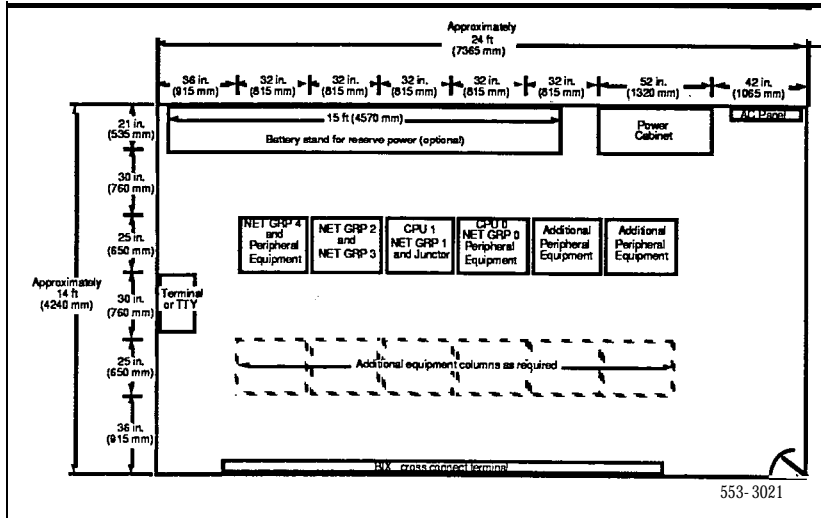

Note: This sample floor plan may vary from your own depending on your system needs and the size/arrangement of your equipment room. SL-1 Option 71 may also expand to a second row of Peripheral Equipment modules.

## Floor loading estimates

Floor loading estimates should be obtained in order to plan for proper stacking of modules. (Floor loading is the weight of the system divided by the occupied floor **area**; Point loading is the local pressure exerted by the system feet on the floor.)

Table 10 shows the floor loading estimates for stacking an SL-1 system. The estimates given represent a fully-loaded module complete with pedestal, maximum circuit pack **allowances**, power supplies, and cables.

**Table 10**  
**Floor loading estimates**

<b>Modules</b>	<b>LBS/FT<sup>2</sup> (kPa)</b>	<b>Point Load (lbs/in<sup>2</sup>) (kPa)</b>
One	38.1 (1.8 kPa)	11.0 (75.8 kPa)
Two	60.3 (2.8 kPa)	17.3 (119 kPa)
Three	82.4 (3.9 kPa)	23.7 (163.4 kPa)
Four	104.6 (5 kPa)	30.0 (206.8 kPa)

Note: The numbers under "**LBS/FT<sup>2</sup> (kPa)**" are based on a floor area of the system of 5.64 square feet. These numbers do not include the weight of the optional overhead cable rack. The numbers under "**Point Load (lbs/in<sup>2</sup>) (kPa)**" are based on distributing the system weight among four feet, each with an area of 4.91 square inches; these numbers do not reflect the use of optional casters.



## The building cable plan

The building cable plan should be divided into zones. The zones are typically the termination point of conduits throughout the office. Each zone on the building cable plan should be identified **with** a letter or number, and a block of numbers should be assigned to each zone. Be sure to leave room for expansion. See Figure 8 “Sample building cable plan” for an illustration of zoning.

In addition, the following information and guidelines should be considered:

Each telephone, console, or data set connected to the SL-1 requires telephone wire run from a nearby telephone jack to a cross-connect location. Also, each component connected to the system requires a termination. (Modular jacks should be within 8 ft [2436 mm] of the device.) The location of all devices that interface with the SL-1 should be known.

- Telephone directory number, features, and Office Data Administration System (ODAS) designator of each telephone in the office should also be known.
- Three-pairs of telephone wire should be provided from the telephone or data set location to the distribution frame. Location of all distribution points (main and intermediate) should be known.
- Consoles require a 16-pair (or **25-pair**) cable equipped with an Amphenol-type connector.
- If any existing wire is to be used, ownership of that wire must be clearly defined.
- All wiring carrying high-speed data must pass a verification test at the time of installation. The test is performed as part of the installation procedures.

- A random sampling of in-place wiring is taken during a site survey to ensure that it meets specifications for high-speed lines.
- When telephone cable is run in conduit, that conduit must not be used for any other wiring. The location of conduits and floor ducts, for example, should be known.
- The wiring plan should show the routing of all wiring, the location of each telephone, console, or data set, and any other relevant information about the device. It should also show the location of any power outlets that the device will require. Power outlets must be equipped with safety ground.
- Flat under-carpet cables are not recommended.
- Bridge taps for sets are not recommended.

Figure 8  
Sample building cable plan

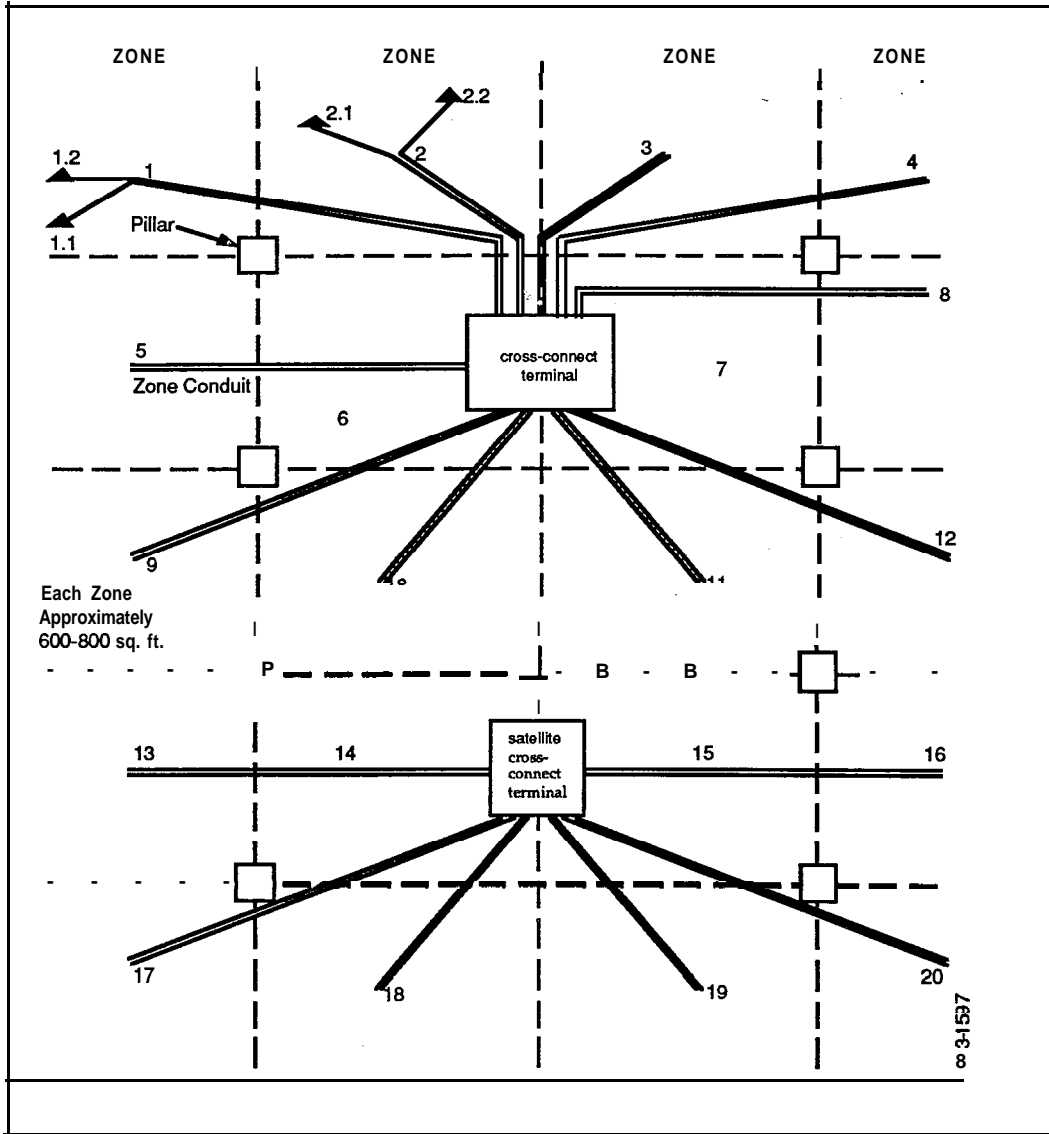

## Wire routing

The routing of all wires for the SL-1 must be specified as part of the plan. To plan wire routing, establish the start and end point of each cable relative to the location of telephones in the office. Remember that each modular jack (8-pin or 6-pin, for example) must be within 8 feet. (2.4 m) of the telephones.

At this point the construction of the office must be investigated to determine the best wiring routes. Consider the following information when performing this task

### Floors

Telephone wire travels along floors in one of two ways:

- **Out in the open:** In some cases wires are tacked to the surface of **walls** and other physical structures. For the safety of employees, wire should never be stretched across the top of floor. Run the wires along baseboards, ceiling mouldings, or door and window casings.
- **Concealed:** In other cases wires are run inside a floor conduit. The conduits can travel between utility closets and jack locations. In some cases the floor conduits connect to a conduit passing through **walls** or ceilings. In all cases the conduit must be used exclusively for telephone cables. The use of under-carpet cables is not recommended.

### Ceilings

The National Electrical Code and local building codes specify what types of telephone wire may be run in each type of ceiling. Local building codes take precedence.

### Walls

Wiring that needs to be run horizontally cannot be blind fed through walls. Cables that need to be run vertically should, when possible, run inside a wall, pole, or similar facility for vertical wire drops.

### Between floors

Telephone utility closets should be located as closely to one another as possible. In many cases, contractors are hired to install the conduit. Local coding laws will specify whether a licensed contractor is required.

### **Electromagnetic Interference (EMI)**

Data degradation may occur if wires travel near strong sources of **electromagnetic** interference. See “The equipment room environment” in this document for common sources of interference.

### **Termination points**

Once the routes for the wires have been determined, the termination points for these wires must be decided. The cables can terminate at various locations:

- main cross-connect terminal-typically in the equipment room
- intermediate cross-connect terminals-typically on each floor in telephone utility closet
- wall jacks or terminal boxes-typically near the **final** device location (within 8 ft [2.4 m])

### **Distribution frames**

House cables terminate on the vertical side of two-sided frames and **cross-connect** to equipment which is typically located on the horizontal. When a color field approach is taken, the house cables typically terminate in the blue field and the equipment terminates on the purple (USA) or white (Canada) field.

In all cases the block where the cables are terminated must be clearly designated with the cable location information and the cable pair assignments.

Note: A log book (cable record) of all termination information should be kept See Table 11 for an example.

Table 11  
Sample cable record

CABLE RECORD									
Customer _____									
Location _____									
Cable _____ Binder _____ Page ____ of ____									
D.M.	TN			NAME	FEATURES / REMARKS	TERMINAL DEVICE	BLOCKS		COLOR
	M	S	C				DF	HOUSE	
									W BL
									W OR
									W OR
									W BR
									W BL
									R BL
									R OR
									R OR
									R BR
									R BL
									R OR
									R OR
									R BR
									R BL
									R OR
									R OR
									R BR
									R BL
									R OR
									R OR
									R BR
									R BL
									R OR
									R OR
									R BR
									R BL
									R OR
									R OR
									R BR
									R BL

553-1595



---

## Preparing for delivery

---

The route the equipment must take from the receiving area to the installation area must be studied in advance. The route should be measured to ensure problem free delivery of the equipment. The following factors must be considered:

### Considerations

- size and security of the loading and storage areas
- capacity and availability of elevators
- the number and size of aisles and doors en route
- restrictions such as bends or obstructions in halls
- floor loading capacity of the loading, storage, and equipment room **areas**
- number of steps and stairways
- dimensions of fully-loaded, packaged system complete with shipping pallet (**39"W x 30"D x 70"H**)

Note: The SL-1 system is shipped with a software package, three **UEMs**, a pedestal, and a shipping pallet (five inches high). The **fourth** UEM is shipped separately. Refer to Table 9 for the weight and dimensions of an SL-1 system.



In addition, here are some questions to consider when preparing for delivery:

- Has a request been made for equipment delivery?
- Is a list of all equipment ordered available on site?
- Are transportation arrangements to premises completed?
- Is assistance available to prepare the switchroom?

**From unloading area to equipment room**

- Are unloading/unpacking facilities available?
- Are unloading/unpacking tools available? (pallet jack, for instance)
- Is there access to and from unloading area to equipment room?
- Is the equipment room threshold large enough for the equipment to enter?

*Note:* The equipment should be located as close to the final installation area as possible. This will provide for an easier, perhaps safer, installation.

## Equipment handling precautions

The following general guidelines should be followed when handling **SL-1** equipment:

- Circuit packs, disks, and tapes are very sensitive to **static** discharge; all static electricity should be discharged from **the** body prior to handling.
- Circuit packs should be handled carefully: only handle packs by the edges, only remove and insert packs when necessary, and only unpack or handle packs away from machinery such as electric motors or transformers.
- If your system is using reserve power, the batteries may weigh in excess of 500 pounds each and may be packaged four to a shipping pallet. To prevent stressing of the floor, do not place the pallets **side-by-side** in the equipment room.
- Special ramps supplied with the product must be used to move the product off the pallet. Follow the instructions on unloading the machine provided on **the** side of the product. (See CAUTION box below.)



### CAUTION Lifting the pedestal

**The** pedestal of the SL- 1 must never be pried up in order to lift the stack. This could cause major damage to the pedestal. Carefully slide the pedestal and associated stack manually, and use the special ramps provided **with** your system.



---

## Preparing for installation

---

The following items should be provided at the time of installation:

- Work orders
- Equipment room floor plan
- Building cable plan
- Installation, Administration and Maintenance Manuals, and User Guides
- Installation plan
- Delivery equipment (pallet jack, for instance)
- **Unloading/unpackaging** instructions

### Work orders

The Work order may include:

- Terminal Number (TN) assignments
- Directory Number (DN) assignments
- individual terminal, data unit feature assignments
- terminals and user profiles
- system and terminal cross-connect assignments
- a detailed listing of the equipment ordered
- administration database entries for features and services

**Note:** The work order will vary depending on the distributor for a specific system.

## Equipment room floor plans

The equipment room floor plans should show the location of:

- each SL-1 module, power module, and future expansion module (UEM)
- a reserve power unit (if applicable)
- maintenance and administration terminal and printer (if equipped) and printer locations (if applicable)
- the cross-connect terminal
- the AC panel and outlets
- any cable racks
- miscellaneous external equipment (data units, modems, etc.)
- auxiliary processors

Note: The suggested floor plans are provided for your assistance. Depending on the complexity of your equipment room, your floor plan may vary from the ones provided in this document.



## Cabling plan

The cabling plan should show:

- cable routing and designation information
- location of peripheral devices and **printers** (if applicable)
- directory numbers (**DNs**) assigned to each peripheral device and Office Data Administration System (**ODAS**) designators (if the software package is equipped)
- features available to each terminal
- type of cable *or* wiring to each terminal, printer, and **PC**
- location of cross-connect terminal
- location of conduits, floor ducts, including access points (junction boxes and hand-holes)
- auxiliary processors

## The installation plan

The installation plan may consist of a floor plan, a cabling plan, and an ITS (Installation and Test Sequence) chart. The chart shows typical installation tasks, the sequence of the tasks, and task start and duration information.

## Manuals

The following manuals should be at hand when installing an SL-1:

- ***SL-1 master index (553-3001-000)***
- ***SL-1 installation and maintenance guide***
- ***SL-1 planning & engineering guide***
- ***SL-1 X11 software guide***
- Product Bulletins (where applicable)
- User Guides

See the References list in “About this document” located at the beginning of this publication for more information.

## Preinstallation inspections

The following items should be inspected and signed off prior to starting the installation:

- Equipment room
- General inspections
- Reserve power (if applicable)

## Equipment room inspections

An equipment room inspection ensures that the following conditions are met:

- physical and environmental requirements met
- system power and utility outlets installed and tested
- lighting installed and working
- AC power distribution installed according to Northern Telecom specifications
- equipment room is dry, clean, and ready for installation
- equipment locations have been marked on the equipment room floor
- entranceways, doorways, halls, and elevators from the loading dock to the equipment room are large enough for system transport
- terminal, printer, and PC locations ready
- sufficient wiring is provided
- single point grounding is implemented
- sufficient and appropriate terminal connecting blocks are provided\_



## General inspections

General inspections ensure that the following conditions are **met**:

- building cross-connect terminals are provided
- conduits or floor ducts to terminal locations **are installed** (including service fittings)
- access conduit for raceway is in place
- sufficient terminal blocks are provided
- sufficient cross-connect **wire** is provided

## Reserve power inspections

For reserve power inspections if batteries are used, ensure that the following conditions are **met**:

- reserve power room is well ventilated and operating at optimum temperature (specific gravity readings are based on a temperature of **77° F (25° C)**)
- proper lighting is available
  - reserve power room is located within manufacturer's recommended proximity to the switch
- protective equipment is available (goggles, face shields, acid-resistant gloves, protective aprons, water for rinsing eyes/skin, and bicarbonate **soda**)
- reserve power room is well secured
- floor loading requirements are met
- reserve power room is accessible (no blocking of doorway)
- noise levels meet OSHA standards 1910.5 or local standards internationally
- reserve power area properly interfaces to the equipment

Note: For detailed instructions on battery usage, see ANSI/IEEE Standard 450-1987: "IEEE Recommended **Practive** for Maintenance, Testing, and Replacement of Large Lead Storage Batteries for Generating Stations and Substations."

An Uninterruptable Power Supply (UPS) **is used** for reserve power in **AC**-powered systems. It includes basic and supporting equipment, including rectifier/charger, inverter, controls and instrumentation. A battery bank is a separate item but may be required together with the UPS. The following items should be inspected and signed off prior to starting the installation:

- Environmental requirements are **met**: both operating and storage/transportation.
- Other requirements are met such as flammability, reliability (**MTBF**), and electrostatic discharge.
- Since a UPS also makes use of batteries, see “Reserve power inspections” above for more details on pre-installation inspections.

Note: Refer to the manufacturer’s specifications for details on the storage and operating environment of UPS. Temperature and humidity ranges should be considered for proper maintenance of the UPS.

SL-1

## **System options 21, 51, 61,71**

Installation planning

Copyright © 1990 Northern Telecom  
All rights reserved.  
Information subject to change without notice.  
Release 1.0  
Standard  
January 29, 1990  
Printed in U.S.A.



553-3001-151

SL-1

# System options 21, 51, 61, 71

System engineering  
Standard

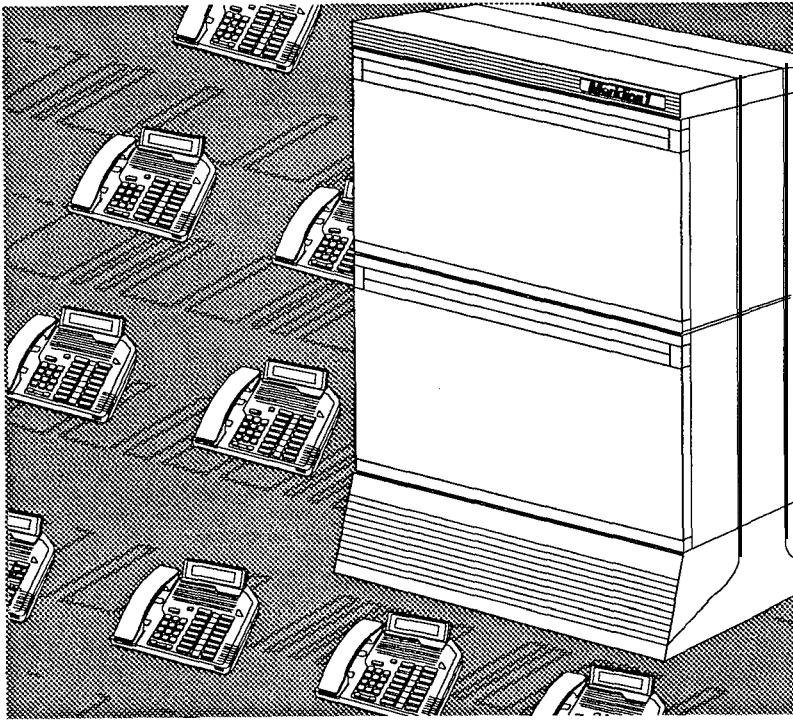

**nt** northern  
telecom

**Meridian 1**  
Communication Systems





---

SL-1

# **System options 21, 51, 61, 71**

System engineering

---

Publication number: **553-3001-151**

Document Status: Standard

Document release: 1.0

Date: January **29, 1990**

---



© 1990 Northern Telecom

All rights reserved.

---

System engineering **553-3001-151**



---

# Revision history

---

**January 29, 1990**

Standard release 1 .0

---

# About this document

---

## General information

The following document has been updated to include new naming conventions and system engineering guidelines for the SL-1 System. Acronyms and abbreviations for the new names are identified in the text using parentheses.

This section provides the necessary information to:

- determine the equipment requirements for an SL-1 installation
- configure and assign equipment in the system
- distribute traffic equally over the system components
- maintain traffic distribution and equipment utilization levels when adding or removing equipment or when altering the system configuration

*Note:* The figures and limits used in this section are not necessarily typical and should not be interpreted as limits of the system capacity. The figures should be altered to suit the application of a particular system. Memory and real time figures, which vary for each generic of SL-1, are given in an appendix to this publication.



## References

See the *SL-I planning & engineering guide* for

- *Master index* (553-3001-000)
- *System overview* (553-3001-100)
- *Installation planning* (553-3001-120)
- *System engineering* (553-3001-151)
- *Power engineering* (553-3001-152)
- *Sparesplanning* (553-3001-153)
- *Equipment identification and ordering* (553-3001-W)

See the list of fine and trunk circuit descriptions in *the Master index* (553-3001-000) for specific references to lines and trunks.

See the *SL-I installation and maintenance guide* for

- *System installation procedures* (553-3001-210)
- *Circuit pack installation and testing* (553-3001-211)
- *Installation procedures for telephone sets and attendant consoles* (553-2201-215)
- *Extended systems installation* (553-3001-250)
- *Disk drive upgrade procedures* (553-3001-251)
- *General maintenance information* (553-3001-500)
- *Fault clearing* (553-3001-510)
- *Hardware replacement* (553-3001-520)

See the *SL-1 XII software guide* for an overview of software architecture, procedures for software installation and management, and a detailed description of all XI 1 features and services. This information is contained in two documents:

- *XII software management* (553-3001-300)
- *XI1 features and services* (553-3001-305)

See the *SL-I XII input/output guide* (553-3001-400) for a description of all administration programs, maintenance programs, and system messages.

---

# Contents

---

<b>System organization and capacities</b>	<b>1</b>
Option 21	1
Options 51 and 61	1
Option 71	5
Universal Equipment Modules	6
<b>CE/PE UEM (NT8D11AC/DC)</b>	<b>7</b>
Description of <b>CE/PE UEM (NT8D11 AC/DC)</b>	8
<b>CPU/Network UEM (NT6D39AA/DC)</b>	<b>10</b>
Description of <b>CPU/Network UEM (NT6D39AA/DC)</b>	11
<b>CPU UEM (NT8D34AA/DC)</b>	<b>12</b>
Description of <b>CPU UEM (NT8D34AA/DC)</b>	13
<b>Network UEM (NT8D35AA/DC)</b>	<b>14</b>
Description of <b>Network UEM (NT8D35AA/DC)</b>	15
<b>Intelligent Peripheral Equipment UEM (IPE)</b> <b>(NT8D37AA/DC)</b>	<b>16</b>
Description of <b>IPE UEM (NT8D37AA/DC)</b>	17
<b>PE UEM (NT8D13AA/DC)</b>	<b>19</b>
Description of <b>PE UEM (NT8D13AA/DC)</b>	20
<b>Remote Peripheral Equipment (RPE) UEM</b> <b>(NT8D47AA/DC)</b>	<b>21</b>
Description of <b>RPE UEM</b>	22
<b>InterGroup UEM (NT8D36AA)</b>	<b>23</b>
Description of <b>InterGroup UEM</b>	23
System capacities	24
Network <b>terminating</b> capacity	24
Network traffic capacity	24
Memory capacity	24
Configuration capacities	25

---

---

<b>Definitions</b>	<b>27</b>
General rules	27
UEM and column designations	27
Configurations	28
Peripherals	29
Traffic distribution	30
Traffic definitions	31
Equipment utilization	33
Network loop traffic	33
Partitioning	33
Network loop assigning	34
PE card distribution	35
IPE card slot assigning	36
Card slot priority	36
Class of service priority	36
Trunks	36
Attendant consoles	37
Telephone sets	37
Card slot assignment	37
Assigning cards	38
Terminal number assigning	39
Ongoing assignment plan	39
Cutover study	39
Threshold study	39
Equipment relief	40
Assignment records	40
<hr/>	
<b>Provisioning guidelines</b>	<b>41</b>
<hr/>	
<b>Step 1</b>	<b>43</b>
Growth forecast	43
Example	43
<hr/>	
<b>Step 2</b>	<b>45</b>
CCS per terminal	45
Comparative method	45
Manual calculation of <b>ccs/t</b>	48
Manual calculation example:	49
Default method	51
Default method example:	51

---

---

<b>Step 3</b>	<b>53</b>
Trunks required	53
Example	53
<hr/>	
<b>Step 4</b>	<b>54</b>
Line, trunk, and console load	54
Line load	54
Trunk load	54
Console load	54
<hr/>	
<b>Step 5</b>	<b>55</b>
DTR requirements	55
Model 1	56
Model 2	56
Model 3	56
Model 4	56
Detailed calculation: method 1	57
Detailed calculation: method 2	59
<hr/>	
<b>Step 6</b>	<b>60</b>
Total system load	60
<hr/>	
<b>Step 7</b>	<b>61</b>
Network loop requirements	61
Non-blocking configuration with Superloop Network	62
Blocking configuration with Superloop Network	62
Enhanced Network Cards (QPC414)	62
DTI/PRI cards	63
<hr/>	
<b>Step 8</b>	<b>65</b>
Network groups	65
<hr/>	
<b>Step 9</b>	<b>66</b>
PE cards	66
<hr/>	
<b>Step 10</b>	<b>67</b>
PE UEMs	67

---

<b>Step 11</b>	<b>68</b>
TDS/Conference loop	68
<b>Step 12</b>	<b>69</b>
Memory	69
<b>Step 13</b>	<b>70</b>
Equipment summary	70
<b>Feature calculations</b>	<b>71</b>
Calculations with Authorization Code	71
Calculations with Centralized Attendant Service (CAS)	72
Calculations with Charge Account for CDR	73
Calculations with Direct Inward System Access (DISA)	74
Example	74
Calculations with Integrated Message Service (IMS)	75
<b>Worksheets</b>	<b>77</b>
Card distribution	103
<b>Tables</b>	<b>115</b>

---

# System organization and capacities

---

The SL-1 System is basically organized into different kinds of systems and can support from 32 to 10,000 analog or digital lines, depending on traffic and feature requirements. System configurations are determined by customer requirements and the physical limitations of the equipment. Both AC and DC power options are available.

The following figures show a high level view of each system configuration. For information on power packs, cooling system, and system monitor, refer to the *System overview* (553-3001-100) document, Both AC and DC power is available.

## Option 21

This cost effective unit comes in two sizes. The standard version is a single-CPU system that may contain up to four **UEMs**. It can be configured with an optional fan shelf for up to two **UEMs** (AC or DC power options). The modified version, Option **21A**, is an optimized single-module AC system. See Figure 1-1.

## Options 51 and 61

Option 51 is a CPU/Network-based (NT-type) system; one shelf contains single CPU/half group; it serves from 800 to 1,000 lines. Option 61 is a CPU/Network-based (NT-type) system; two shelves contain dual CPU/full group; it serves from 1,000 to 2,000 lines. See Figures 2 and 3.

Figure I-1  
Option 21 with multiple UEMs

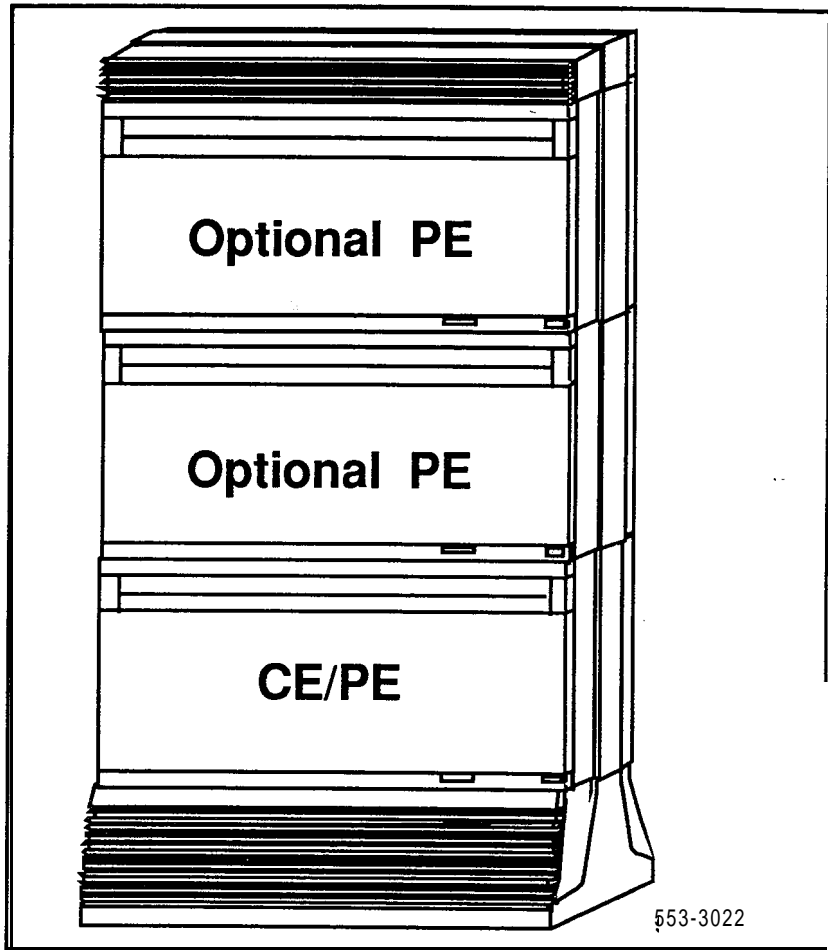

Figure 1-2  
Option 51 with half network group

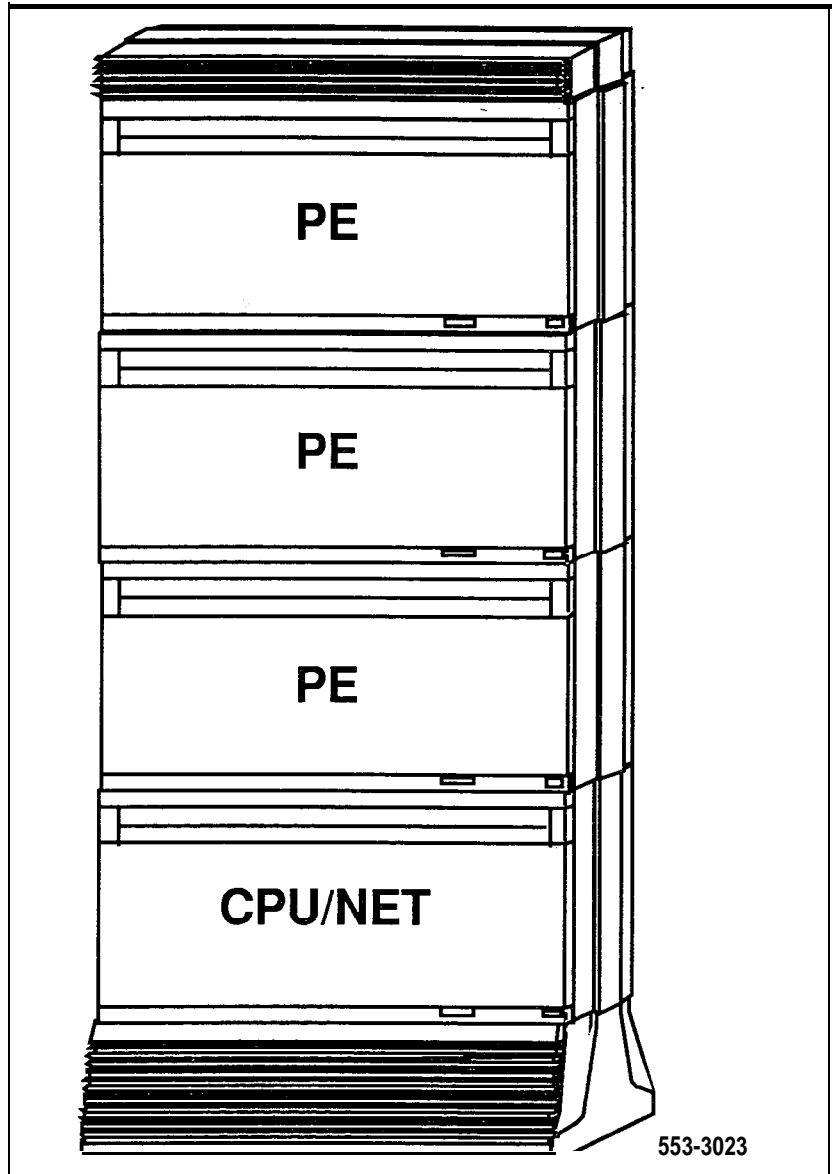
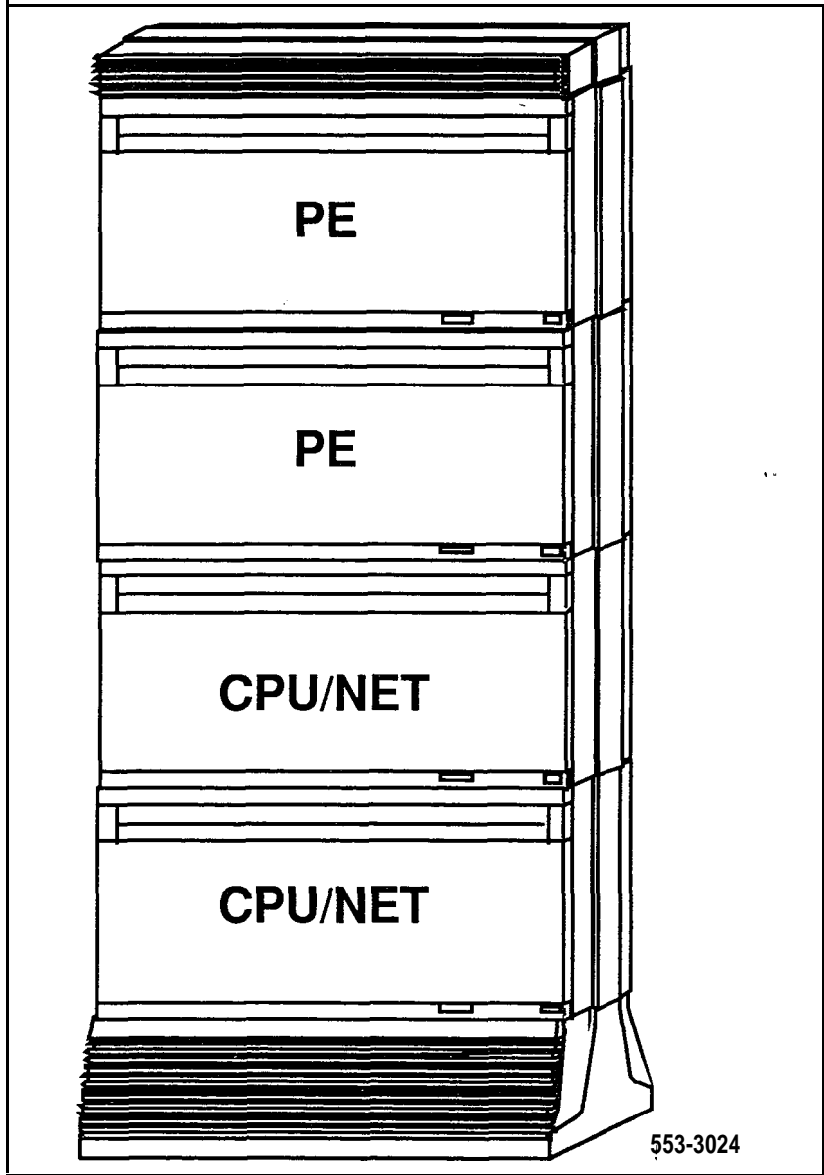



Figure 1-3  
Option 61 with full network group



## Option 71

Option 71 is a multiple network group machine with redundant CPU and serves from 2,000 to 10,000 lines. See Figure 1-4.

Figure 1-4  
Option 71 with multiple network group

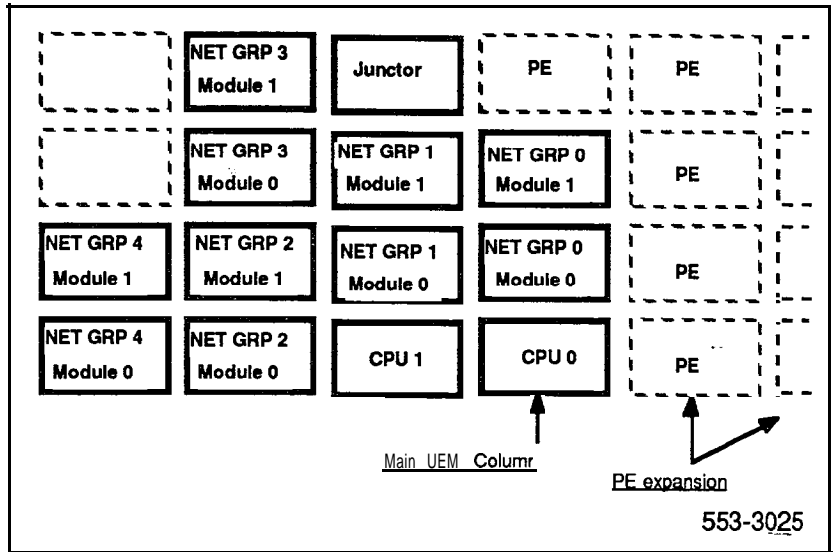

**Note:** This document has been updated to include new naming conventions. Acronyms and abbreviations for the new names are identified in the text using parentheses.

## Universal Equipment Modules

This document has been updated to include new naming conventions. Acronyms **and** abbreviations for the new names are identified in the text using parentheses.

Each configuration of the SL-1 consists of a **number** of **Universal Equipment Modules (UEMs)**. Each module can be identified by its function. There are nine different types of UEMs:

**Table I-1**  
**Identification of UEMs**

Universal Equipment Module	Number required per system
Common/Peripheral Equipment 1 (CE/PE) (NT8D11AC/DC)	1
CPU/Network (NT6D39AA/DC)	1
CPU (NT8D34AA/DC)	2
Network (NT8D35AA/DC)	2 (see note)
Peripheral Equipment (PE) (NT8D13AA/DC)	depends on system size
Intelligent Peripheral Equipment (IPE) (NT8D37AA/DC)	depends on system size
Remote Peripheral Equipment (RPE) (NT8D47AA/DC)	depends on system size
<b>InterGroup (NT8D36AA)</b>	1 (see note)
Meridian Mail (NT6D44AA/DC)	Optional

Note: In Option 61, two network **UEMs** are required per network group; **InterGroup UEMs** are required in SL-1 Option 61 only. For more information on **UEMs**, refer to *Equipment identification and ordering* (553-3001-I 54).

**CE/PE UEM (NT8D1 1 AC/DC)****Table 1-2****Identification of CE/PE UEM (NT8D11 AC/DC)**

<b>Unit</b>	<b>Number required per UEM</b>
Common/Peripheral Equipment Power Supply <b>(CE/PE Pwr Sup)</b> <b>(AC-NT7D14AA) (DC-NT7D04AA)</b>	1
Floppy Disk Interface card (FDI) (QPC742)	1
CPU card (QPC687)	1
Memory/Peripheral Signalling card <b>(NT8D19AA)</b>	1
<b>Network/DTR card (NT8D18AA)</b>	1
<b>Conference/TDS card</b> <b>(NT8D17AA)</b>	1
Network cards	≤ 6
Enhanced Serial Data Interface (ESDI)	
Serial Data Interface Paddle Board (Dual Port) <b>(NT8D41AA)</b> supporting 6 SDI ports	≤ 3
Peripheral Equipment Line Cards	≤ 10

Note: This document has been updated to include new naming conventions. Acronyms and abbreviations for the new names are identified in the text using parentheses.

### Description of **CE/PE UEM (NT8D11AC/DC)**

Slots 1, 2, and 3 are reserved for the following circuit cards:

- Floppy Disk Interface (**FDI**) (QPC742)
- Central Processing Unit (CPU) (QPC687)
- Memory/Peripheral Signalling Card (**NT8D19AA**)

Slots 4 through 9 in the Network area can be used by the following cards:

- Superloop Network Card (**NT8D04AA**) serves one superloop (four loops).
- Enhanced Network Card (QPC4 14) serves two loops.
- **Conference/TDS** Card (**Conf/TDS**) (**NT8D17AA**) uses two loops in the Network area; at least one **Conf/TDS** is required in the system.
- Digital Trunk Interface Card (DTI) (QPC472) occupies two slots.
- D-Channel Interface Card (**DCHI**) (QPC757)
- Quad Serial Data Interface Card (QSDI) (QPC84 1)
- Floppy Disk Unit (**FDU**) (**NT8D68AA**)

*Note:* FDU occupies two slots and resides either in Network slots 4-9 or Peripheral Equipment (**PE**) slots 0-9, depending on slot availability. If all slots in the first column of the **CE/PE UEM** are occupied, FDU can reside in the second PE module.

Slot 10, **Net/Cont**, must **be** occupied by the **Network/DTR** card (**NT8D18AA**) which combines the functions of a Network and Peripheral Equipment controller and a **Digitone** receiver. The card provides ten loops for ten PE cards.

Peripheral Equipment slots 0 through 9 can be occupied by any of the following cards:

- Digital Line Card (**NT8D02AA**)
- Analog Line Card (**NT8D03AA**)
- Analog Message Waiting Line Card (**NT8D09AA**)
- Universal Trunk Card (**NT8D14AA**)
- E&M Trunk Card (**NT8D15AA**)
- Floppy Disk Unit (**NT8D68AA**)—see note above

**CPU/Network UEM (NT6D39AA/DC)**

Table 1-3

**Identification of CPU/Network UEM (NT6D39AA/DC)**

<b>Unit</b>	<b>Number-required per UEM</b>
Common Equipment Power Supply (CE Pwr Sup) ( <b>AC-NT8D29AB</b> ) ( <b>DC-NT6D41AB</b> )	1
Network cards (QPC414)	≤ 8
Superloop Network cards ( <b>NT8D04AA</b> )	≤ 6
Clock Controller/Serial Data Interface (SDI) (QPC471 / <b>QPC139</b> )	1
Peripheral Signalling card (QPC43)	1
Three Port Extender ( <b>QPC441</b> )	1
Mass Storage interface (MSI) (QPC584) or Floppy Disk Interface (FDI) ( <b>NT8D68AA</b> )	1
CPU Function card (QPC579)	1
CPU Interface card (QPC580)	1
Changeover and Memory Arbitrator (CMA) card (QPC581)	1
768K Memory card (QPC583)	1
Serial Data Interface (SDI) card (QPC139)	1
Multi-Drive Unit (MDU) ( <b>NT8D69AA</b> ) or Floppy Disk Unit (FDU) ( <b>NT8D68AA</b> )	1
Note: The Multi-Disk Unit (MDU) requires <b>MSI cards</b> ; the Floppy Disk Unit (FDU) requires FDI cards. <b>MDU/FDU</b> occupies two slots.	

**Description of CPU/Network UEM (NT6D39AA/DC)**

Slots 1 through 8 are reserved for the following cards:

- Network cards (QPC4 14 or NT8D04AA)

The rest of the slots contain the following cards:

- slot 9 : Clock Controller or Serial Data Interface (SDI)
- slot 10: Peripheral Signaling
- slot 11: Three Port Extender (3PE)
- slot 12: Mass Storage Interface (MSI)
- slot 13: SDI
- slot 14: CPU function
- slot 15: CPU interface
- slot 16: Changeover and Memory Arbitrator (CMA)
- slot 17: Memory

**Note:** This document has been updated to include new naming conventions. Acronyms and abbreviations for the new names are identified in the text using parentheses.



**CPU UEM (NT8D34AA/DC)**

**Table I-4**  
**Identification of Single CPU UEM**

Unit	Number- required per UEM
Common Equipment Power Supply (CE Pwr Sup) ( <b>AC-NT8D29AB</b> ) ( <b>DC-NT6D41AB</b> )	1
CPU function card (QPC579)	1
CPU interface card (QPC580)	1
Changeover and Memory Arbitrator ( <b>CMA</b> ) card (QPC581)	1
Memory cards (QPC583)	2
Mass Storage Interface card (MSI) (QPC584) or Floppy Disk interface (FDI) ( <b>NT8D68AA</b> ):	1
Segmented Bus Extender (SBE) cards (QPC215)	≤ 5
Clock Controller card (QPC471 or QPC775 international)	1
Multi-Drive Unit (MDU) ( <b>NT8D69AA</b> ) or one DTI (Digital Trunk Interface) card (QPC742)	1
Bus Terminating Unit (BTU) (QPC477 - <b>A20</b> or - <b>A21</b> )	2
<b>Note:</b> MDU requires MSI cards; FDU requires FDI cards; MDU occupies three slots in the UEM, FDI occupies two.	

**Description of CPU UEM (NT8D34AA/DC)**

Slots 1-2 are reserved for the following cards:

- Memory cards (**QPC581**)

The rest of the slots contain the following cards:

- slot 3: CMA
- slot 4: CPU interface
- slot 5: CPU function
- slot 6: **SDI**
- slot 7: **MSI**
- slots 8-12: Segmented Bus Extender (SBE)
- slot 13: available
- slot 14: Clock Controller
- slot 15: Mass Storage Unit (MSU) or Floppy Disk Unit (**FDU**), or Primary Rate Interface (**PRI**)/**Digital** Trunk Interface (DTI)

*Note:* This document has been updated to include new naming conventions. Acronyms and abbreviations for the new names are identified in the text using parentheses.

**Network UEM (NT8D35AA/DC)**

**Table I-5**  
**Identification of Network UEM**

<b>hit</b>	<b>Number_ required per UEM</b>
Common Equipment Power Supply (CE Pwr Sup) (AC-NT8D29AB) (DC-NT6D41 AB)	1
Three-Port Extender (3PE) QPC441)	1
Inter-Group Switch (IGS) cards QPC412)	2
Peripheral Signalling card QPC43)	1
Serial Data Interface (SDI) card QPC139)	1
Superloop Network cards NT8D04AA)	≤ 4
Network cards (QPC414)	≤ 8
Digital Trunk Interface (DTI) QPC472) cards	≤ 6
Conference/Tone and Digit Switch (Conf/TDS) (NT8D17AA) cards	≤ 8
Bus Terminating Units (BTU) QPC477)	2

Note: IGS cards are for Option 71 only. In Options 51 and 61, these slots are occupied by Clock Controller Cards [QPC471 B or higher vintage].) The four Superloop Network cards (NT8D04AA) or eight QPC414 Network cards can be configured in any combination for a total of 16 loops. Also, as a DTI/PRI-only UEM Network UEM contains one CE Pwr Sup and up to six DTI/PRI cards.

**Description of Network UEM (NT8D35AA/DC)**

The slot assignment of cards is as follows:

- slots 1: Three Port Extender (3PE)
- slots 2-3: Intergroup Switch (**IGS**) (for Option 71 only), **PRI/DTI**, or **SDI**
- slot 4: Peripheral signaling
- slots 5- 12: Network cards
- slot 13: **PRI/DTI** or **SDI**
- slot 14: **PRI/DTI**
- slot 15: not used

**Note:** This document has been updated to include new naming conventions. Acronyms and abbreviations for the new names are identified in the text using parentheses.

**Intelligent Peripheral Equipment UEM (IPE) (NT8D37AA/DC)**  
**Table I-6**  
**Identification of IPE UEM**

Unit	Number required per UEM
Peripheral Equipment Power Supply (PE Pwr Sup) ( <b>AC-NT8D06AA</b> ) ( <b>DC-NT6D41AB</b> )	1
AC Ringing Generator ( <b>NT8D21AA</b> ) (required only when analog cards are present)	1
Controller-2 (Cont-2) ( <b>NT8D01 AD</b> ) Card or Controller-4 (Cont-4) ( <b>NT8D01AC</b> ) Card (See note.)	1
Line cards or a combination of analog, digital, trunk, and <b>Digitone</b> receiver cards (Table I-7 shows the port-to-line card orientation.	≤ 16

**Description of IPE UEM (NT8D37AA/DC)**

The NT8D37 IPE backplane (NT8D3701) contains 16 card slots. Slots 0-15 are for line cards. Slot 16 is for miscellaneous. The Controller Card is situated near **the** center of the module, between slot 7 and slot 8.

If one or two superloops are to be served, use **Cont-2**; If three or **four** superloops are to be served, use **Cont-4**. The Controller-4 card is required when a large number of Integrated Voice and Data (**IVD**) lines are **non**-blocking and when they require, on average, more than four Digital Line Cards (Dgtl **LCs**) per IPE DEM.

The nominal capacity of the IPE UEM is 256 Integrated Voice and Data (IVD) or analog lines; however, a typical configuration of the PE UEM includes a combination of line, trunk, and **Digitone** Receiver cards which provide about 160 lines with the appropriate trunks.

**Table 1-7**  
**Port-to-line card orientation for IPE (NT8D37AA/DC) line cards**

<b>Line card</b>	<b>Ports served</b>
Digital Line Card <b>(NT8D02AA)</b>	16 Digital
Analog Line Card <b>(NT8D03AA)</b>	16 Analog
Analog Message Waiting Line Card <b>(NT8D09AA)</b>	16 Analog with Message Waiting features
Universal Trunk Card <b>(NT8D14AA)</b>	≤ 8 trunks with any combination of CO/DID/RAN/Page
<b>Digitone</b> Receiver Card <b>(NT8D18AA)</b>	8 channels of DTMF or MF receivers
E&M Trunk Card <b>(NT8D15AA)</b>	≤ 4 trunks with any combination of E&M/Page trunks

**PE UEM (NT8D13AA/DC)**

Table I-8

**Identification of PE UEM (NT8D13AA/DC)**

Unit	Number required per UEM
Peripheral Equipment Power Supply (PE Pwr Sup) (AC-NT8D06AA) (DC-NT6D41 AB) See note.	1
AC Ringing Generator (Rng Gen) (NT8D21 AA) (required only when analog cards are present.)	1
Dual Loop Peripheral Equipment Buffer (QPC659)	1
Line cards or a combination of analog, digital, trunk, and <b>Digitone</b> receiver cards	≤ 10
Note: QPC710 DTR can be used if required by the customer; If QPC710 DTR is used <b>with</b> a single loop on the QPC659, then slot 10 cannot be used. Both AC and DC versions of PEPS are available.	

The **NT8D13** PE backplane (**NT8D1302**) contains 10 line card positions. The PE Buffer is situated near the center of the module, with five line cards to the left and five line cards to the right.

The nominal capacity of the PE UEM (**NT8D13AA/DC**) is 160 Integrated Voice and Data (IVD) or analog lines; however, a typical configuration of the PE UEM (**NT8D13AA/DC**) includes a combination of line, trunk, and **Digitone** Receiver cards which provide about 100 lines with the appropriate trunks.



**RPE UEM (NT8D47AA/DC)**

**Table I-9**  
**identification of RPE UEM**

Unit	Number per UEM	Number per RPE loop
Common/Peripheral Equipment Power Supply (CPE Pwr Sup) (NT7D14AA)	1	
1.5Mbps Converter cards (QPC62)	2	1
2Mbps Converter cards (QPC66)	2	1
Carrier Interface cards (QPC99)	2	1
Local Carrier Buffer (QPC63)	2	1
Remote Peripheral Buffer (QPC65)	2	1
Carrier Maintenance card (QPC67)	1	1
Digital Trunk Interface cards (QPC472) / Primary Rate Interface (PRI) (QPC720)	≤ 3	
<b>Note: Each RPE UEM can support up to two RPE loops.</b>		

### Description of RPE UEM

The slot assignment of cards is as follows:

- slot 1: **PRI/DTI** (optional)
- slot 2: 1.5 Mb converter
- slot 3: 2 Mb converter
- slot 4: carrier interface
- slot 5: remote peripheral
- slot 6: local carrier buffer
- slot 7: carrier interface
- slot 8: 2 Mb converter
- slot 9: 1.5 Mb converter
- slot 10: carrier maintenance
- slots 11-12: **PRI/DTI** (optional)

The minimum configuration for RPE consists of an RPE UEM at the main PBX site and the following equipment at the remote site:

- one RPE UEM (NT8D47AA/DC)
- one PE UEM (NT8D13AA/DC)
- one pedestal
- one top cover

The engineering rules for RPE UEM are the same as for the existing RPE shelf except there are three 2" slots available for **DTI/PRI** Cards in the RPE UEM.

### InterGroup UEM (NT8D36AA)

Figure I-5

#### InterGroup UEM

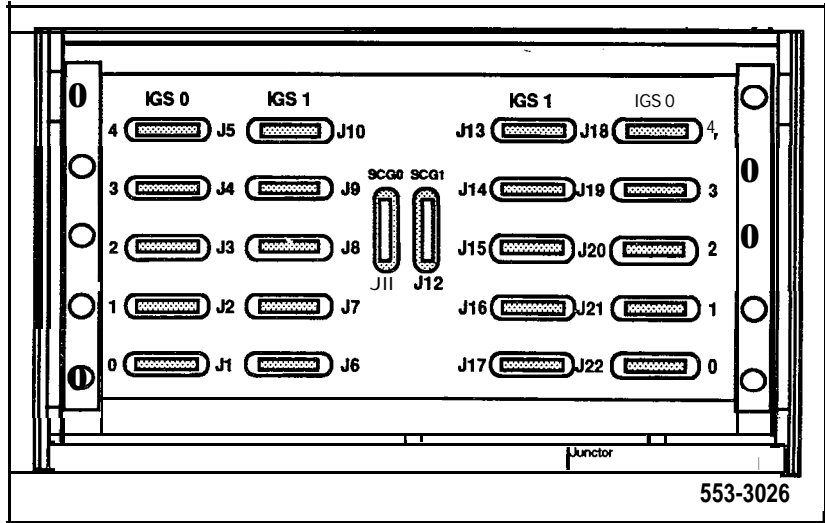

#### Description of InterGroup UEM

The NT8D36AA InterGroup UEM provides a path for the switching of traffic between the network groups in the system. Faceplate cables from the Segmented Bus Extender (SBE), System Clock (SCG), and InterGroup Switch (IGS) circuit cards are connected to the InterGroup Module.

## System capacities

### Network terminating capacity

The Superloop Network Card (NT8D04AA) has four network loops grouped as one superloop. One superloop can serve up to, two Intelligent Peripheral Equipment UEMs (IPE) (NT8D37AA/DC).

### Network traffic capacity

Each superloop is capable of carrying 3500 CCS (or 875 CCS/loop) of combined station, trunk, attendant console and **Digitone** traffic during Average Busy Season Busy Hour (ABSBH) subject to the following grades of service:

- the loss of no more than 1% of the incoming terminating calls, provided the called line is free
- the loss of no more than 1% of the originating outgoing calls in the system, provided an idle trunk is available
- the loss of no more than 4% of the intra-office calls, provided that the called line is free
- no more than 1.5% of the originating calls wait longer than 3 seconds for dial tone
- the loss of no more than 1% of tandem calls, provided an idle outgoing trunk is available

### Memory capacity

The memory capacity is a function of the machine type. Memory requirements are a function of the system size and features available. See Table I-10 for the memory capacities of each system:

**Table I-10**  
Memory capacity per system

System	Memory	Mbytes
Option 21	768K words	1.5
Options 51 and 61	768K words	2.3
Option 71	1.5M words	4.5

### **Configuration capacities**

The maximum configuration capacities of the SL-1 Options **51, 61,** and 71 are:

- 100 customers
- 30 steps in a hunting group
- 8191 speed call lists per system
- 4095 ringing number pickup groups per customer
- 5 12 trunk routes per customer
- 254 members per trunk route
- 4 listed directory numbers per customer (DID only)
- 1 lamp field array per customer, may be repeated once on other console or SL-1 set
- 150 lamps per array (all numbers to be consecutive)
- 63 consoles per customer (Release 8 and later releases)
- 10 feature keys per console
- 20 incoming call indicators per console
- 16 trunk group busy indicators per console
- 2 additional key/lamp strips per console
- 6 additional key/lamp strips per SL-1 set
- 16 input/output devices (TTY etc.)
- 30 appearances of the same directory number

A system may not be able to accommodate simultaneously all the maximum values listed due to system limitations on the real time, memory, or traffic capacity.



---

# Definitions

---

## General rules

Apply the following rules for system engineering when arranging various Universal Equipment Modules (**UEMs**) within an SL- 1.

**Note:** This document has been updated to include new naming conventions. Acronyms and abbreviations for the new names are identified in the text using parentheses.

## UEM and column designations

Columns of Universal Equipment Modules (**UEMs**) are numbered from 0 to 63. The column **with** CPU 0 is Column 0. Within a column, the **UEMs** are numbered as 0 to 3 starting from the bottom UEM.

A UEM column can be built up to a maximum of four **UEMs** before moving to the next column; however, three **UEMs** per column can be configured if it is easier for installation and maintenance.

All the SL-1 Common Equipment (CPU **UEMs**) must be at the bottom or one level up for proper cooling and reliability. The mass storage unit-- Multi-Disk Unit (**MDU**) or Floppy Disk Unit (**FDU**)--is usually located in a CPU UEM and requires lower operating temperatures than the cards. For this reason, do not install **MDU/FDU** in the third or fourth UEM.

The Common Equipment (CE) **UEMs** must be located next to each other at the same horizontal level. The CPU/Network Modules (**NT6D39AA/DC**) (**CNE**) must be located on top of each other.

The CPU, **InterGroup**, and CE **UEMs** must be located in the same vertical column. For these **UEMs**, all inter-UEM cabling must be internal, not

through the I/O panels or EM1 filters. In addition, all vertical routing of the internal signal cables should be done on the right side of a column.

The **InterGroup** UEM should be located at the top of a column and adjacent to the CE **UEMs**.

Peripheral Equipment (**PE** or **IPE**) **UEMs** may be located away from CE and CPU **UEMs** by a maximum network cable length of 45 feet. This means that typically at floor level the CE UEM serving its PE cannot be more than **20** feet apart.

### Configurations

A full network group consists of two half network group **UEMs** stacked one on top of the other. This rule does not apply when the Network Module is used only as a **DTI/PRI** shelf.

SL-1 Option 51 can be configured using one Network Module (half network group) or two Network Modules (full network group). SL-1 Option 71 must be expanded in increments of full network groups.

In multiple-group machines, the addition of network groups should be considered in the floor plans. Make sure the network groups are located in one contiguous equipment bay. One possibility is to provide space for expanding network groups to the left of CPU **UEMs** and Peripheral Equipment (**PE** or **IPE**) to the right of CPU **UEMs**. Another possibility is to keep Peripheral Equipment (**PE** or **IPE**) expansion as a separate bay. See Figure 14 "Option 71 with multiple network group."

## Peripherals

One superloop (the equivalent of four regular loops) should serve two, four, six, or eight segments. A segment is one-fourth of **the** Intelligent Peripheral Equipment (**IPE**)(**NT8D37AA/DC**) shelf containing four slots.

A superloop can serve from one segment to two IPE **UEMs** in increments of one segment, depending on the ratio of TN to TS. Preferably, a superloop should be configured to serve an even number of segments. Assign full traffic and IPE Cards to one superloop before assigning to the next.

For every superloop which has “empty” IPE slots associated with it (because it is not assigned to exact multiples of eight cards), there should be spare traffic to use those slots when the system grows. Future additions of IPE Cards can be made to these superloops.

For traffic purposes, **Network/DTR (Net/DTR)** may be typically assigned to serve 96 lines, 32 trunks, and 8 DTR ports (10 IPE Cards total ) even though it has higher traffic capacity.

The total number of AC Ringing Generators (**Rng Gen**) in a system can be minimized by consolidating all Analog Line Cards in a few IPE **UEMs** and **CE/PE UEM**, if applicable. For traffic and reliability reasons, no more than three-fourths of the IPE and **CE/PE UEMs** should be filled with Analog Line Cards (Anlg **LC**)(**NT8D03AA**) or Analog Message Waiting Line cards (Anlg M/W **LC**) (**NT8D09AA**).

Note: This document has been updated to include new naming conventions. Acronyms and abbreviations for the new names are identified in the text using parentheses.



## Traffic distribution

The traffic distribution in the SL- 1 is **illustrated in** Figure 2-1. This illustration is valid when considering individual customer or system traffic.

**Figure 2-1**  
Traffic distribution over the SL-1

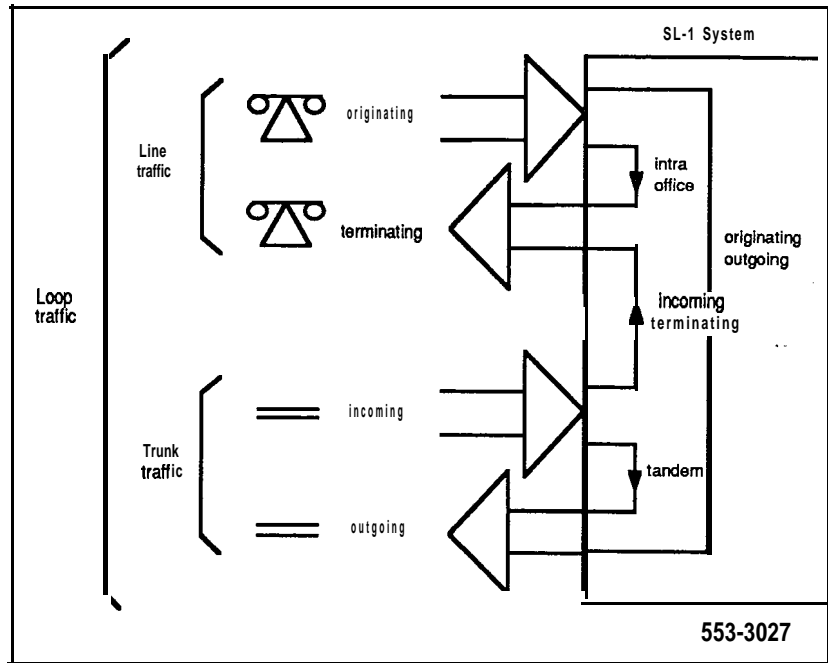

## Traffic definitions

The following are definitions of traffic terminology used in determining the provisioning requirements of an SL-1 System:

- c c s =  
Hundred call seconds. The unit in which amounts of telephone traffic are measured. One **call** which lasts for one hundred seconds equals one c c s.

$$\text{— Line} = \text{IT} + \text{OO} + \text{IOT} + \text{IOO}$$

where:

Line = Line traffic in CCS

IT = Incoming Terminating traffic in CCS.

OO = Originating Outgoing traffic in CCS

IOT = Intra-Office Terminating traffic in CCS

IOO = Intra-Office Originating traffic in CCS

$$\text{— R} = (\text{IOT} + \text{IOO}) / \text{Line}$$

where:

R = Intra-Office Ratio

$$\text{— Loop} = \text{Line} + \text{IT} + \text{OO}$$

where:

Loop = loop traffic in CCS

= Line + Line - R x Line

= Line x (2-R)

$$\text{— Total line capacity} = \text{Total loop capacity} / (2-R)$$

$$\text{— Total trunk capacity} = \text{Total line capacity} \times (1-R)$$

$$= \text{Total loop capacity} \times (1-R) / (2-R)$$

$$\text{— Total I/O capacity} = \text{Total loop capacity} \times R / (2-R)$$

$$\text{— Network} = \text{Total CCS handled by the SL-1 switching network or:}$$

= Traffic received from stations + trunks, attendants, Digitone receivers, conference circuits and special features.

$$\text{— InterGroup} = \text{Traffic flow between two network groups in SL-1s having more than one network group.}$$

## Equipment utilization

Equipment is provided and maintained throughout the SL-1 location life at an 85% utilization level.

## Network loop traffic

The recommended traffic level for a Network superloop is:

- 3500 CCS without Digitone-using apparatus
- 2975 CCS with Digitone-using apparatus

The traffic level per **network** loops depends on whether or not the Peripheral Equipment uses **Digitone** trunks.

## Partitioning

The SL-1 can be configured as a partitioned or non-partitioned system when it is to serve more than one customer.

A partitioned system dedicates each customer and the customer's associated lines and trunks to actual partitioned segments of the system in terms of loops and shelves. Consoles and **Digitone** receivers are normally spread over all loops and shelves in a partitioned system.

In a non-partitioned system, all customers, trunks, lines, consoles, and **Digitone** receivers are spread over all loops and shelves. A non-partitioned system provides the following advantages:

- fewer traffic loops are required
- fewer PE shelves and cards are required
- system call-carrying capacity is more easily achieved and maintained
- customers are distributed evenly over the loops
- load balancing is more easily accomplished by being done on a system basis rather than for each customer

## Network loop assigning

When assigning the loop number in systems equipped with two Network **UEMs**, the load should be distributed evenly across both **UEMs**. Loops should be assigned in the order shown in Table 2- 1. Record the loops used in Worksheet L provided at the end of this document.

The total number of Peripheral Equipment **UEMs** should be distributed over the total number of voice and data loops. Normally, one PE UEM is assigned to a superloop. However, one PE UEM **can** be assigned from one half-superloop to as many as four superloops, depending on the concentration of Terminal Numbers to **Timeslot** ratio. See Table 2-1 for details on loop number assignments.

Total number of loops = 4 x No. of Superloop Network Cards + 2 x No. of **Enhanced** Network Cards

**Table 2-1**  
**Loop number assignment**

Number of groups	Number of loops
1	28
2	56
3	84
4	112
5	140

Note: The assignments shown may vary depending on system configuration and size. Conference (CONF) and Tone and Digit Switch (TDS) may be assigned any even loop number. Do not assign the odd loop number associated with CONF or TDS loop.

## PE card distribution

Using Worksheet M (provided at the end of this document), determine the total **number** of each type of PE cards (500, **SL1**, TRK, DTR, etc.) per PE UEM.

Using Worksheets N and O (also provided at the end of this document), determine the number of Multiple Appearance Groups (MAG) assigned to each loop. (Also refer to Worksheet S for a Multiple Appearance Group Record sheet). Multiple appearance groups should be balanced over all the loops.

Multiple appearance groups that call each other frequently should not be assigned to the same loop, but should be assigned to the same network group to reduce inter-group calls in multiple network group systems. Large multiple appearance groups of more than 10 **TNs** should be avoided, if possible.

Users within a multiple network group system that call each other frequently should be assigned to the same network group. Similarly, **trunk** groups that are used primarily by certain groups of users should be assigned within the same network group as the users.

---

## Intelligent Peripheral Equipment (IPE) card slot assigning

### Card slot priority

Input messages from card slots 1 and 0 in each IPE module (card slot 0 in each EPE shelf) are directed to a high priority input buffer. The input messages from the remaining slots on each IPE module are directed to a priority input buffer. The system processes the low priority input buffer only when the high priority buffer and the SL-1 and 500 output buffers are empty, thereby minimizing input buffer delay on signals from devices in high priority card slots. This mechanism is important for certain types of trunks that require critical timing. It is relatively unimportant for other devices.

### Class of service priority

Class of service priority is completely unrelated to card slot priority. Selected sets and trunks can be assigned a high priority (HPR) class of service. Requests for dial tone from high priority sets and trunks are processed before sets and trunks assigned a low priority (LPR) class of service. The fewer the sets and trunks assigned as high priority, the better the service received during heavy load conditions.

### Trunks

Incoming Delay Dial, Wink Start, and similar trunks have a timing advantage at seizure time when assigned to card slots 1 and 0 in the IPE module. TIE/DID trunks with DTMF pulsing (incoming) used on the high priority card slots (1 and 0) have a better chance of attaching a DTR before the first digit arrives. Trunks using 10 or 20 pps (incoming) should not be assigned to high priority slots to minimize the number of high priority input messages during pulsing.

The recommended card slot assignments for trunks is as follows:

- AIOD type trunks must always be assigned to card slots 1 and 0.
- Delay Dial, Wink Start and DTMF type trunks should be assigned to a high priority card slot if possible.
- Trunks using 10 or 20 pps (incoming) should not be assigned to a high priority card slot if possible.
- Other types of trunks may be assigned to high priority card slots to avoid glare, but can also be assigned card slot 2 through 10.

### **Attendant consoles**

Attendant consoles should never be assigned to a high priority card slot. Too many high priority messages from attendant consoles assigned to these card slots can result in delays in output messages to attendant consoles, sets and trunks. Attendant consoles should always be assigned to card slots 2 through 10. A large number of attendant consoles should not be assigned to the same network loop since buffer overflow may result (ERR030 and **ERR040** messages on the TTY).

### **Telephone sets**

SL-1-, 500-, and 2500-type sets can be assigned to any card slot. However, there is no service or **user advantage** gained by assigning sets to high priority card slots. One disadvantage of assigning a 500-type set to high priority card slots is the possibility of input messages during pulsing delaying output buffer processing.

### **Card slot assignment**

Use Worksheet P (provided at the end of this document) to assign cards to the UEM slots. Calculate the average load after all packs of a particular type have been assigned. Total the load and keep a running total. If this method is followed, cards need not be interchanged at the end of the process because of load imbalance.

---

## Assigning cards

### Procedure 2-1

#### Order for assigning cards

- 1 Assign cards requiring a card slot 1 assignment (high priority slot).
- 2 Assign cards for high-usage trunks, such as CO trunks.
- 3 Assign cards for low-usage trunks, such as paging and dictation.
- 4 Assign cards for attendant consoles.

*Note:* For the PE UEM (NT8D13AA/DC), card slot 1 is reserved for high priority signaling. For the IPE UEM (NT8D37AA/DC), both card slots 0 and 1 are reserved for high priority signaling.

- 5 Assign **Digitone** receiver cards.
- 6 Assign cards for sets associated with multiple appearance groups.
- 7 Assign remaining cards. On a system which has a high density of **Digitone** sets, assign the least number of 500 line cards to loops which have **Digitone** receivers assigned.

*Note:* Loops and Conference/Tone and Digit Switch Cards (**Conf/TDS**) should be evenly distributed across Network **UEMs** and groups.

- 8 Calculate the total load per UEM.
- 9 Calculate the total load per loop.
- 10 If required, rearrange card assignments to balance the load.



### Terminal number assigning

Once the cards are assigned to the PE **UEMs**, the individual units on each card can be assigned. Use Worksheet Q (at the end of this document) to record the Terminal Number (TN) assignments. TN **0000** cannot be used on superloop 0. Therefore, use loop 0 for Enhanced Network or Conference/IDS **Card** to avoid wasting a port.

### Ongoing assignment plan

Use the initial assignment records to complete an SL-1 System assignment plan for each equipped network **loop** in the system. (See Worksheet R at the end of this document). From this system loop profile, an assignment plan can be developed for each loop. Assignments for future trunks, multiple appearance group stations, consoles, and **Digitone** receiver requirements can be developed for each loop according to the profile.

### Cutover study

Once the system has been placed in service, a cutover study should be undertaken. The results of this study are used to update the loop profiles and create a new assignment plan. Ongoing assignments should follow the new assignment plan until the first customer busy-season trunking study. At that time loop threshold measurements are set so that at least one of the predominant busy hours would produce a CCS load output.

### Threshold study

From the threshold study printout the loop profile should be updated, and a new assignment plan should be developed. At this time, it may be advisable to estimate the system capacity for future growth. If the growth capacity is sufficient to last beyond the next annual threshold study, assignments can continue in accordance with the assignment plan. If the growth capacity is not sufficient, plans should be made to establish a tentative date when new equipment (loops or shelves) must be ordered and installed. This date generally should be controlled by physical capacity and tracked by total working physical terminations.

## Equipment relief

When additional equipment is installed, assignments should be concentrated into the new loop or shelves until the **first** threshold study. At that time, the loop profile would be updated and a new loading plan developed. At any time when a loop exceeds **500** CCS (based on 85% traffic level), that loop should be suspended from future assignments. If any loop should encounter service problems, that loop should be suspended and sufficient load removed to reduce service levels to an acceptable level.

## Assignment records

The following printouts are available from the system and should **be** used in addition to worksheets to assist in maintaining assignment records:

- list of trunk route members
  - list of **TN** blocks
- list of unused card positions
  - list of unused units
- DN to TN matrix

Refer to **X11 Features** and **services** (553-3001-305) for information on how to obtain and manipulate data in the SL-1.



---

# Provisioning guidelines

---

## Procedure 3-1 Provisioning guidelines

Note: To determine the equipment requirements, follow the provisioning guidelines in the order shown below. Worksheets and Tables are all provided at the end of this document.

- Step 1 Define and forecast growth.
- Step 2 Estimate ccs per terminal.
- Step 3 Calculate number of trunks required.
- Step 4 Calculate line, trunk, and console load.
- Step 5 Calculate **DTR** requirements.
- Step 6 Calculate total system load.
- Step 7 Calculate number of superloops required.
- Step 8 Calculate number of Network groups required.
- Step 9 Calculate number of PE cards required.

- Step 10** Calculate number of PE **UEMs required.**
- Step 11** Provision **TDS/Conference** loops.
- Step 12** Calculate memory requirements.
- Step 13** Assign the equipment/prepare equipment **summary.**

Note: The provisioning methods described in this document are based on a non-partitioned system using the figures provided. The figures are intended as a guide only.

The details of each step are given below in the following steps:



---

## Step 1: Define and forecast growth

---

The first step in provisioning an initial SL-1 is to forecast the growth of the system at the 2-year and **5-year** interval in terms of telephone stations.

The number of telephones required when the system is placed in service (cutover) is determined by the customer. If the customer is unable to provide a 2-year and 5-year station growth forecast, then a customer estimate of annual growth of personnel in percent is used to estimate the number of stations required at the 2-year and **5-year** interval.

### Example

A customer has 500 employees and requires 275 telephones to meet the system cutover. The customer projects an annual increase of 5% of employees based on future business expansion. The employee growth forecast is:

- 500 employees x 0.05 (% growth) = 25
- 525 employees x 0.05 = 27 additional employees at 1 year
- 552 employees x 0.05 = **28** additional employees at 2 years
- 580 employees x 0.05 = 29 additional employees at 3 years
- 609 employees x 0.05 = 31 additional employees at 4 years
- 640 employees x 0.05 = 32 additional employees at 5 years

The ratio of telephones to employees is  $275/500 = 0.55$ .

To determine the number of telephones required from cutover through a **5**-year interval, the number of employees required at cutover **1, 2, 3, 4,** and 5 years is multiplied by the ratio of telephones to employee.

— 500 (employees) x 0.55 (ratio) = 275 telephones required at cutover

— 525 (employees) x 0.55 (ratio) = 289 telephones required at 1 year

— 552 (employees) x 0.55 (ratio) = 304 telephones required at 2 years

— 580 (employees) x 0.55 (ratio) = 319 telephones required at 3 years

— 609 (employees) x 0.55 (ratio) = 335 telephones required at 4 years

— 640 (employees) x 0.55 (ratio) = 352 telephones required at 5 years

This customer requires 275 telephones at cutover, 304 telephones at 2 years, and 352 telephones at 5 years.

Every Directory Number (**DN**) assigned to an NE-500 or NE-2500 set requires a Terminal Number (TN). Each SL-1 set requires a TN.

Determine the number of NE-500, NE-2500, and SL-1 TN required for each customer, and enter this information on Worksheet A (provided at the end of this document). Perform this calculation for the cutover, 2-year, and **5**-year interval.



---

## Step 2: Estimate ccs per terminal

---

### CCS per terminal

The station and trunk CCS per terminal ( $\text{CCS}/T$ ) for an initial installation of an SL- 1 can be estimated using any one of the following methods.

- Comparative method
- Manual calculation
- Default method

### Comparative method

Three existing systems are selected which have an historical record of traffic study data. The criteria for choosing comparative systems is as follows:

- similar line size ( $\pm 25\%$ )
- similar business (bank, hospital, insurance, manufacturing, etc.)
- similar locality (urban or rural) ---

Once the similar customers have been selected, their station, trunk, and intra  $\text{CCS}/T$  are averaged. These average figures are then applied to calculate trunk requirements for the SL- 1 being provisioned. Table 3- 1 gives an example.



**Table 3-1**  
**Example of station, trunk, and intra ccs/t averaging**

	Customer A	Customer B	Customer C	Total	Average
Line size	200	250	<b>150</b>	<b>600</b>	2.00
Line <b>CCS/T</b>	4.35	4.75	3.5	12.6	4.2
Trunk <b>CCS/T</b>	2.6	3.0	2.0	7.6	2.5
Intra <b>CCS/T</b>	1.7	1.75	1.5	4.95	1.65

If only the trunk **CCS/T** is available, then multiply the trunk **CCS/T** by 0.5 to determine the **intra CCS/T** (assumes a normal traffic pattern of 33% incoming calls, 33% outgoing calls, and 33% **intra-system** calls). The **trunk CCS/T** and **intra CCS/T** are then added to arrive at the line **CCS/T**. Table 3-2 gives an example when only trunk **CCS/T** are known.

**Table 3-2**  
**Example of ccs/t averaging when only trunk ccs/t are known**

Trunk Type	No. of Trunks	Grade of service	Load in CCS	No. of Terms	CCS/T
DID	16	P.01	294	234	1.2
c o	14	P.02	267	234	1.14
TIE	07	P.05	116	215	0.54
Paging	02	10 ccs/trunk	20	207	0.09
Out WATS	04	30 ccs/trunk	120	216	0.54
FX	02	30 ccs/trunk	60	216	0.27
Private Line	04	20 ccs/trunk	60	04	20
			TOTAL	959 ccs	23.79

Note: The individual ccs/t per trunk group are not added to form the trunk ccs/t. The trunk ccs/t is the total trunk load divided by the total number of lines at cutover.

## Manual calculation of ccs/t

Normally, the customer can estimate the number of **trunks** required at cutover and specify the grade of service to be maintained at the **2-year** and **5-year** period. (If not, the comparative method can be used).

The number of trunks can be read **from the** appropriate **trunking** table to select **the** estimated usage on the trunk group. The number of lines at cutover that are accessing the group are divided into the estimated usage. The result is the **CCS/T** which can be used to estimate trunk requirements.

### Manual calculation example:

— Line **CCS/T** = 6.2

— Trunk **CCS/T** = 4.1

— 2 Console = 30 CCS

**Cutover**    Line **ccs** =  $275 \times 6.2 = 1705$   
              Trunk **ccs** =  $275 \times 4.1 = 1128$   
              Subtotal = 2833  
              Console **ccs** = 30  
                          **Total system load = 2663**

**2 Years**    Line **ccs** =  $304 \times 6.2 = 1885$   
              Trunk **ccs** =  $304 \times 4.1 = 1247$   
              Subtotal = 3132  
              Console **ccs** = 30  
                          **Total system load = 3162**

**5 Years**    Line **ccs** =  $352 \times 6.2 = 2183$   
              Trunk **ccs** =  $352 \times 4.1 = 1444$   
              Subtotal = 3627  
              Console **ccs** = 30  
                          **Total system load = 3657**

This method is used for each trunk group **in the** system, with the exception of small special services trunk groups (Tie Trunks, Wats, FX). Normally, the customer will tolerate a lesser grade of service on these trunk groups. Table 3-3 has been developed which lists the estimated usage on special services trunks.

**Table 3-3**  
**Estimated load per trunk (ccs)**

Tie Trunks	30 ccs
Foreign Exchange	30 ccs
Out WATS	30 ccs
In WATS	30 ccs
Paging	10 ccs
Dial Dictation	10 ccs
Individual Bus Lines	20 ccs

## Default method

Studies have been conducted which estimate the average line **CCS/T** to never be greater than 5.5 in 90 percent of all businesses. If attempts to calculate the **CCS/T** using the comparative method or the manual calculation have not been successful, the default-of 5.5 line **CCS/T** can be used.

The network line usage is determined by multiplying the number of lines by 5.5 **CCS/T**. The total is then multiplied by 2 to incorporate the **trunk CCS/T**. Unfortunately, when this method is used, the intra **CCS/T** is added twice to the equation, and the result could be over provisioning if the intra **CCS/T** is high.

Another difficulty experienced with this method is the inability to forecast individual trunk groups. The trunk and intra **CCS/T** is forecasted as a sum group total. Examples of the Default method and the Manual calculation method are shown in Table 3-4 for comparison.

### Default method example:

— 275 Stations at Cutover

— 304 Stations at 2 years

— 352 Stations at 5 years

Cutover  $275 \times 5.5 \text{ (CCS/T)} \times 2 = 3025 \text{ CCS Total System Load}$

2 Year  $304 \times 5.5 \text{ (CCS/T)} \times 2 = 3344 \text{ CCS Total System Load}$

5 Year  $352 \times 5.5 \text{ (CCS/T)} \times 2 = 3872 \text{ CCS Total System Load}$

**Table 3-4**  
**Default Method and Manual Calculations analysis**

	<b>DefaultMethod</b>	<b>Manual Calculations</b>	<b>Difference</b>
<b>Cutover</b>	<b>3025</b>	<b>2863CCS</b>	<b>162 CCS</b>
<b>2Years</b>	<b>3344</b>	<b>3162 CCS</b>	<b>182 CCS</b>
<b>5Year5</b>	<b>3872</b>	<b>3657 CCS</b>	<b>215 CCS</b>

---

## Step 3: Calculate number of trunks required

---

### Trunks required

The values obtained through any of the three previous methods should now be entered on Worksheet A (provided at the end of this document). Add your calculations to the worksheet. Once the trunk **CCS/T** is known, and a grade of service has been specified by the customer, the number of trunks required per trunk group to meet the cutover, 2-year and **5-year** requirements of a customer can be determined as follows:

#### Example

The customer requires a Poisson 1% blocking grade of service (see Table 3-A at the end of this document). The estimated trunk **CCS/T** is 1.14 for a DID trunk group. With the cutover, 2-year and 5-year number of lines, the total trunk CCS is determined by multiplying the number of lines by **the trunk CCS/T**:

Cutover 275 (lines) x 1.14 (trunk **CCS/T**) = 313.5 CCS

2 year 304 (lines) x 1.14 (trunk **CCS/T**) = 346.5 CCS

5 year 352 (lines) x 1.14 (trunk **CCS/T**) = 401.28 CCS

Use Table 6-1 to determine the quantity of trunks required to meet the trunk CCS at cutover, 2-year and **5-year** interval. In this case:

- 17 DID trunks are required at cutover
- 18 DID trunks are required at 2 years
- 21 DID trunk are required at 5 **years**

Note: For trunk traffic greater than 4427 ccs, allow 29.5 **ccs/trunk**.

---

## Step 4: Calculate line, trunk, and console load

---

### Line, trunk, and console load

Once the quantity of trunks required has been estimated, enter the quantities on Worksheet A (in Step 1) for the cutover, **2-year** and **5-year** interval. This calculation must be performed for each trunk group to be equipped. The total trunk **CCS/T** is the sum of each individual trunk group **CCS/T**. This value is also entered on Worksheet A. (See Worksheet A at the end of this document.)

### Line load

The line load is calculated by multiplying the total number of **500** and SL-1 line Terminal Numbers (TN) by the line **CCS/T**. The number of TN is determined as follows:

- one TN for every Directory Number (**DN**) assigned to one or more 500 or **2500-type** set
- one TN for every SL-1 set.
- one TN for every digital set **M2xxx** or **M3xxx** without data option.
- two **TNs** for every **M2xxx** or **M3xxx** set with data option.

### Trunk load

The trunk load is calculated by multiplying the total number of digital sets, 500, and SL-1 line TN having access to the trunk route by the **CCS/T** per trunk route.

### Console load

The console load is determined by multiplying the number of consoles by 30 CCS per console.



## Step 5: Calculate DTR requirements

---

Once station and trunk requirements have been determined for the complete system, the **Digitone Receiver (DTR)** requirements can be calculated. DTR are shared by all customers in the system and should be distributed equally over all the network loops.

Tables 6-3 through 6-6 (at the end of this document) are based on models of PBX traffic environments and can be applied to determine DTR needs in most cases. When the system being provisioned does not fall within the bounds of these models or is equipped with any special features, the detailed calculations must be performed for each feature and **the number of Digitone receivers must accommodate** the highest result.

Some special features are:

- Centralized Attendant Service (CAS)
- Direct Inward System Access (DISA)
- Authorization Code
- Charge Account for Call Detail Recording (CDR)
- Integrated Message Service (IMS)

*Note:* Refer to the section “Feature calculations” for more information on the above features.



From the appropriate table (See **Table 6-3 to Table 6-6** at the end of this document) determine the number of DTR required and the DTR load for cutover, two-year, and five-year interval. Record this information on Worksheet B (located at the end of this document).

The following models are based on some common PBX traffic measurements:

### Model 1

Table 6-3 is based on the following factors:

- 33% intra-office calls, 33% incoming calls, and 33% outgoing calls
- 1.5% dial tone delay grade of service
- no **Digitone** DID trunks or incoming **Digitone** tie trunks

### Model 2

Table 6-4 is based on the following factors:

- assumes same traffic pattern as model 1
- the system has **Digitone** DID trunks or incoming **Digitone** tie trunks
- Poisson 0.1% blockage grade of service

### Model 3

Table 6-5 is based on the following factors:

- 15% intra-office calls, 28% incoming calls, and 56% outgoing calls
- 1.5% dial tone delay grade of service
- no **Digitone** DID trunks or incoming **Digitone** tie trunks

### Model 4

Table 6-6 is based on the following factors:

- assumes same traffic pattern as model 3
- the system has **Digitone** DID trunks or incoming **Digitone** tie trunks
- Poisson 0.1% blockage grade of service

## Detailed calculation: method 1

This method can be used when there are no incoming **Digitone** DID trunks and the following is assumed:

- Receiver traffic is assumed to be inflated by 30% to cover unsuccessful dialing attempts.
- Call holding times used in Intra-office and Outgoing Call calculations can be assumed to be 135 seconds if unknown.
- Receiver holding times assumed to be 6.2 and 14.1 seconds for **intra** and outgoing calls respectively.
- Factor  $(1-R)/2$  in (1) Outgoing, assumes that Incoming calls and Outgoing calls are equal. R is the intra-office ratio.

### Procedure 3-2

#### Detailed calculation method 1

- 1 Calculate **Digitone** calls:

$$\text{Intra-office traffic} = \frac{100 \times \text{Digitone station traffic (ccs)}}{\text{call holding time in seconds}} \times \frac{R}{2}$$

$$\text{Outgoing traffic} = \frac{100 \times \text{Digitone station traffic}}{\text{call holding time in seconds}} \times \frac{(1-R)}{2}$$

- 2 Calculate total receiver traffic:

$$\text{Total receiver traffic} = \frac{1.3 \times [(6.2 \times \text{Intra}) + (14.1 \times \text{outgoing})]}{100}$$



**3** Calculate average holding time:.

$$\text{Average holding time} = \frac{(6.2 \times \text{Intra}) + (14.1 \times \text{outgoing})}{\text{Intra calls} + \text{outgoing calls}}$$

- 4 Refer to Table 6-7 or Table 6-8 (at **the end** of this document) and use answers from (2) and (3) above to determine the number of receivers required.

**Detailed calculation: method 2**

This method can be used when incoming **Digitone** trunks are included in the system. This method uses the same assumptions as method 1, with the receiver holding time assumed to be 2.5 seconds for a DID call.

**Procedure 3-2****Detailed calculation method 1**

- 1** Calculate Intra-office and Outgoing **Digitone** calls as shown in Method 1 (1):

$$\text{DID calls} = \frac{100 \times \text{Digitone station traffic (in ccs)}}{\text{call holding time in seconds}}$$

- 2** Calculate total receiver traffic:

Total receiver **traffic** =

$$\frac{1.3 \times 6.2 \times \text{Intra} + (1.3 \times 14.1 \times \text{outgoing}) + (2.5 \times \text{DID calls})}{100}$$

- 3** Refer to Table 6-9 (at the end of this document) and use the answer from (2) above to determine the number of **digitone** receivers required.

## Step 6: Calculate total system load

---

Total the line, trunk, console, and **Digitone** receiver load for each customer to arrive at a total load figure for each customer for the cutover, **2-year**, and 5-year interval. Enter this figure on Worksheets B and C (at the end of this document).

## Step 7: Calculate number of superloops required

---

The system network loop requirement is the total of all individual customer loops and **superloops** required. The number of network loops and superloops required is calculated for each customer for the cutover, **IL-year**, and 5-year interval. Network loops and superloops are provisioned at cutover on the basis of the 2-year loop requirement figure.

To determine the number of superloops required, first separate the traffic supported by Enhanced Network Cards (QPC414). Enhanced Networks support the traffic carried by Data Line Cards (QPC3 11, **QPC430**, **QPC432**), RPE, and **DTI/PRI**. Remaining traffic including DTR traffic should be engineered for superloops.

Number of Superloop Network Cards or Number of superloops =

Traffic to be handled by Superloop Network  
2975

These figures are based on an 85% utilization level. The value obtained should be rounded to the next higher number. For Option 21, exclude the traffic carried by 10 Intelligent Peripheral Equipment (**IPE**) Cards in the first module before computing the number of Superloop Network Cards.

## Non-blocking configuration with Superloop Network

For non-blocking applications (or non-blocking part of the system), **provide** one superloop per 120 Terminal Numbers (**TNs**). Each line or trunk is one TN except that an integrated voice and data line is two **TNs** (assuming dam port is configured).

## Blocking configuration with Superloop Network

For applications where blocking is allowed, one superloop can serve up to 512 lines (1024 **TNs**). The actual number of lines will depend on the traffic requirement of the lines.

## Enhanced Network Cards (QPC414)

The traffic carried by Enhanced Network Cards includes the data traffic, RPE traffic, and **DTI/PRI** traffic (which includes both the data and voice traffic).

Provide separate loops for RPE and **DTI/PRI** traffic. Based on 85% utilization, the number of loops required is calculated as follows:

$$\text{Number of loops} = \frac{\text{Traffic required to be carried by Enhanced Network Cards}}{560}$$

$$\text{Number of Enhanced Network Cards} = \frac{\text{Number of loops}}{2}$$

The value obtained should be rounded to the next higher number.

## DTI/PRI cards

Digital Trunk Interface Cards (**DTIs**) provide the interface between the SL-1 switch and the **T-1/DS 1** Digital transmission trunks. Digital trunks are offered in the group of 24 trunks. The number of DTI Cards required can be found from Table 3-5 when the **DTI/PRI** traffic is known.

**Note:** The number of **DTI/PRI** loops = number of **DTI/PRI** cards

**Table 3-5**  
**Number of DTI cards required when DTI/PRI**  
**traffic is known**

<b>DTI/PRI traffic (CCS)</b>	<b>Number of DTI cards</b>
1 - 507	1
508 - 1201	2
1202 - 1935	3
1936 - 2689	4
2690 - 3456	5
3457 - 4231	6
4232 - 5006	7
5007 - 5781	8
over 5781	provide <b>8+</b> one DTI for each 774 ccs in excess of 5781 ccs.

Note: In a Network module, if two network slots are available but not contiguous, the Superloop Network Card or Enhanced Network Card can be moved to create a 2" slot for DTI/PRI. The Superloop Network Card can be plugged into the left or right half of the "superslot" to achieve this purpose.

For non-blocking applications, the Ring Again feature must be provided since blocking may occur at the far end of the trunk.

Since the DTI/PRI Card physically occupies two network slots, therefore, the number of DTI/PRI Cards should be multiplied by 2 to obtain the required number of network slots.

DTI/PRI Cards can be plugged into a Network module, a Common/Peripheral Equipment module, a Common Equipment module, a CPU module, or Remote Peripheral Equipment modules. After all essential cards are configured in these UEMs, estimate the available slots for DTI/PRI. If enough slots are not available for all DTI/PRIs required, a special DTI/PRI-only Network module can be added to the system.

## Step 8: Calculate number of Network groups required

Compute the number of Network groups based on the total number of loops required (excluding conference and tone loops). The following equation should be used: (Also refer to Table 3-6.)

$$\text{Total number of loops} = 4 \times \text{no. of Superloop Network Cards} + 2 \times \text{no. of Enhanced Networks}$$

**Table 3-6**  
**Number of groups based on the total number of loops required**

Number of groups	Number of loops
1	28
2	56
3	84
4	112
5	140

*Note:* Use Worksheet C (at the end of this document) if no superloop is required. If the total number of loops required exceeds 22, then a multiple group system should be installed.

Based on the above criteria, installing a multiple group system at the start is more cost-effective than converting to a multiple group system (from a single group system) between the 2-year and 5-year interval.



## Step 9: Calculate number of PE cards required

---

Enter the number of **Digitone** receivers required (from Worksheet B) at the cutover, 2-year, and **5-year** interval on Worksheet D. Use a separate worksheet for the cutover, 2-year, and 5-year intervals.

Using the information on Worksheet A, enter the number of **M2xxx TNs**, **M3xxx TNs**, **NE-500/2500** TN, SL-1 TN, and trunk TN required at the cutover, 2-year, and **5-year** interval (for all customers).

Divide each entry by the number of terminal number assignments per card, round up to the next highest figure, and total the number of cards required.

Calculate the number of new cards and old cards separately.

*Note:* Worksheets are provided at the end of this document.

## Step 10: Calculate number of PE UEMs required

---

The number of PE **UEMs** provided at cutover is based on the **2-year** estimate of PE cards required and an 85% utilization level. The maximum capacity of an Intelligent Peripheral Equipment (IPE) Module is 256 Integrated Voice and Data (IVD) or analog lines; however, a typical configuration should include a combination of line, trunk, and **digitone** receivers which provides up to 160 lines with appropriate trunks.

Divide the number of PE cards required at 2-years by 8.5, round to the next higher figure, and enter this value on Worksheet D (at the end of this document).

To compute the number of Peripheral Equipment (**PE**) **UEMs**, total the number of line cards, trunk cards, and **Digitone** receiver cards required at 2 years by 13.6 and round to the next higher integer figure. Enter this value into Worksheet D (located at the end of this document).

Calculate the number of **IPE UEMs** and **PE UEMs** required.

## Step 11: Provision TDS/Conference loops

---

Tone and Digit Switch (TDS) and Conference (CONF) loops are provisioned according to the two-year figure for the number of network loops required. All systems should be equipped with a minimum of two TDS and two CONF loops.

Refer to Table 6-10 (at the end of this document) to determine TDS and CONF loop requirements for systems other than SL-1 S. Enter these figures on Worksheet F (at the end of this document).

## Step 12: Calculate memory requirements

---

Refer to the end of this document and use Worksheets G through I to calculate memory needs. The two-year figure for sets, consoles, trunks, for example, should be used when calculating. Once the total memory needs are determined, add an additional 10% to the total.

## Step 13: Assign the equipment / prepare equipment summary

---

### Equipment summary

Use Worksheet J (at the end of this document) to record the equipment requirements for the complete system at cutover. Proceed to assign the equipment. The equipment summary may have to be updated as a result of assigning procedures. The equipment summary, once finalized, may be used to order the equipment for the system.



—



Faint, illegible text or markings in the bottom left corner.

---

# Feature calculations

---

## Calculations with Authorization Code

With authorization code, the receiver holding times are changed from 6.2 seconds to 19.6 seconds for intra-office calls, and from 14.1 seconds to 27.5 seconds for outgoing calls.

Use these figures in (2) and (3) of Detailed calculation Method 1, and (2) of Detailed calculation Method 2 when calculating the DTR requirements for a system with the authorization code option.

The following is assumed.

- All **Digitone** intra-office and outgoing calls require authorization.
- The average number of Special Services **Prefix** (SSP) digits is 2 (the maximum is 4).
- The average number of authorization code digits is 10 (range is 1 to 14 digits).
- The average receiver holding time is 13.4 seconds.

*Note:* See Table 6-7 at the end of this document.

## Calculations with Centralized Attendant Service (CAS)

This method is used to determine the DTR requirements for the main location of a system equipped with the CAS option. The following is assumed:

- All attendant calls presented through **Release Link Trunks' (RLT)** from a remote PBX require **Digitone** Receivers.
- The average number of digits dialed is 4.
- Average receiver holding time is 6.2 seconds.

### Procedure 4-1 Calculations with CAS

- 1 Calculate the attendant calls from the remote PBX:  
$$\text{attendant call} = \frac{100 \times \text{attendant traffic from the remote (CCS)}}{\text{attendant work time (in seconds)}}$$
- 2 Add the attendant calls to the intra-office calls calculated in (1) of Method 1, and proceed with the remaining calculations of Method 1.

## Calculations with Charge Account for CDR

The receiver holding time for outgoing calls changes from 14.1 seconds to 20.8 seconds.

Apply this change to (2) and (3) in Method 1 and (3) in **Method 2** to determine DTR requirements for a system with the charge account for CDR option.

The following is assumed:

- 50% of the **Digitone** outgoing calls require charge account.
- The average number of SSP digits is 2 (maximum is 4).
- The average number of digits in the account number is 10 (range is 2 to 23 digits).
- The average receiver holding time is 13.4 seconds. See Table **6-7**.

### Calculations with Direct Inward System Access (DISA)

This method is used when a system is equipped with DISA. The following is assumed:

- The DISA calls come through DISA trunks or DID trunks.
- 75% of DISA calls require security code.
- The average number of digits in the security code is 4 (range is 1 to 8).
- The DISA receiver holding time is 6.2 seconds.

#### Procedure 4-2 Calculations with DISA

- 1 Calculate the number of DISA calls.

$$\text{DISA calls} = \frac{100 \times \text{DISA traffic}}{\text{call holding time}}$$

- 2 Calculate the DISA receiver traffic.

$$\text{DISA receiver traffic} = \frac{6.2 \times \text{DISA calls}}{100}$$

- 3 Add this traffic to (2) in Method 2 and proceed with the remainder of Method 2 calculations.

## Calculations with Integrated Message Service (IMS)

This method is used when a system is equipped with IMS. The following is assumed:

- Only messaging calls from 2500 sets require **Digitone Receiver** service
- 50-50 split of originating and terminating calls and 135 seconds average call holding time were assumed in Step (a).
- 50% of calls from 2500 sets were intra-PBX calls Step (b).
- In general, a caller will not wait until the completion of Recorded **Announcement** to act (press message button or transfer to attendant). The average time is listening to an announcement is four seconds, (Step d).
- If the actual number of 2500 sets is not known, assume it to be 60% of total lines.

### Procedure 4-3 Calculations with IMS

- 1 Calculate originating calls from 2500 sets of the PBX.  
Calls from 2500 sets =  $\text{CCS/line} \times 100 \times \text{Qty 2500 sets} / (2 \times 135) = A$
- 2 Calculate intra-PBX calls from 2500 sets.  
Intra-PBX **2500-set** calls =  $A \times 0.5 = B$
- 3 Calculate calls requiring service of DTR.  
Calls to DTR =  $B \times 0.5 = C$  where 0.5 is the fraction of B which goes to the messaging service.
- 4 Calculate traffic (CCS) to DTR.  
Messaging CCS to DTR =  $C \times 4/100$   
Messaging CCS should be added to the total DTR traffic to determine the overall DTR requirements.



11/11/11



---

# Worksheets

---

<b>Worksheets</b>	<b>5-1</b>
Growth Forecast: Worksheet A	5-2
Line Usage: Worksheet B	5-4
Network Loop Calculation : Worksheet C	<b>5-6</b>
PE Card Calculations : Worksheet D	5-8
Universal Equipment Module Provisioning : Worksheet E	<b>5-10</b>
Conference Loop Requirements : Worksheet F	<b>5-11</b>
Unprotected Memory Calculations : Worksheet G	5-13
Protected Memory Calculations : Worksheet H	5-16
Program Store Calculations : Worksheet I	5-19
Equipment Summary : Worksheet J	5-21
Balancing Network Loops : Worksheet K	<b>5-23</b>
Load Balancing : Worksheet L	5-24
Card Distribution : Worksheet M	5-26
Multiple Appearance Groups Assignments : Worksheet N	5-27
Station Load Balancing : Worksheet O	5-28
Card Assignment : Worksheet P	5-30
TN Assignment Record : Worksheet <b>Q</b>	5-32
System Assignment Plan : Worksheet <b>R</b>	5-35
Multiple Appearance Group Record : Worksheet S	5-36

**Worksheet A**  
**Growth forecast**

One sheet for each customer, one sheet for the system as a whole.

Customer: \_\_\_\_\_

Date: \_\_\_\_\_



	Cutover	2-year	5-year	CCS/T
<b>Stations</b>				
M2xxx sets				
M2xxx TNs				
M3xxx sets				
M3xxx TNs				
SL-1 Sets				
SL-1 TNs				
500 Sets				
2500 Sets				
2500 TNs				
<b>Trunks</b>				
2-Way				
1-Way In				
1-Way Out				
DID				
TIE				
CCSA				
INWATS				
OUTWATS				
FX				
Private Line				
Dial Dictation				
<b>Paging</b>				
RAN				
AIOD				
DII				
E&M 2W				
E&M 4W				
6 0'				

**Worksheet A continued**  
**Growth forecast**

**Customer:** \_\_\_\_\_

**Date:** \_\_\_\_\_

Line CCS/T \_\_\_\_\_

Total Trunk CCS/T \_\_\_\_\_

Intra CCS/T \_\_\_\_\_

**Worksheet B**

One sheet for each customer for cutover, 2-year, and 5-year intervals. One for the system cutover, 2-year, and **5-year** intervals.

Customer: \_\_\_\_\_ Year: \_\_\_\_\_

Address: \_\_\_\_\_

\_\_\_\_\_

**Line usage**

M2xxx	TN	_____	x	_____	ccs/T	=	_____	ccs
M3xxx	TN	_____	x	_____	ccs/T	=	_____	ccs
SL-1	TN	_____	x	_____	ccs/T	=	_____	ccs
500	TN	_____	x	_____	ccs/T	=	_____	ccs
2500	TN	_____	x	_____	ccs/T	=	_____	ccs

**TOTAL LINE LOAD** = \_\_\_\_\_ ccs

**Trunk usage**

Trunk Route	No of TNs Accessing Route		CCS/T Per Trunk Route	Total CCS Load Per Trunk Route
_____	_____	x	_____ =	_____ ccs
_____	_____	x	_____ =	_____ ccs
_____	_____	x	_____ =	_____ ccs
_____	_____	x	_____ =	_____ ccs
_____	_____	x	_____ =	_____ CCS
_____	_____	x	_____ =	_____ CCS

## Worksheet B continued

**TOTAL TRUNK LOAD = \_\_\_\_\_ CCS**

**Console usage**

**No. of**

Consoles \_\_\_\_\_ x 30cccs = \_\_\_\_\_ Total Console Load

**Digital Receivers**

**Table**

\_\_\_\_\_ # of DTR \_\_\_\_\_ Total DTR Load

\_\_\_\_\_ CCS

**Total Load**

\_\_\_\_\_ CCS

**Worksheet c**

One sheet for each customer.  
 One sheet for the complete system.

Customer: \_\_\_\_\_

Year: \_\_\_\_\_

Address: \_\_\_\_\_

\_\_\_\_\_

Network loop calculation

	Total load (CCS)	ccs /Loop	=	No. of loops	=	Round to next highest figure
Cutover	_____	_____	=	_____	=	_____
2-year	_____	_____	=	_____	=	_____
5-year	_____	_____	=	_____	=	_____

Number of Network Loops Required at 2 Years = \_\_\_\_\_

Number of Network Groups Required at 2 Years = \_\_\_\_\_  
 (Use Table C- 1 Below)

---

**Worksheet C continued**

**Table C-1**  
**Network groups required at 2 years**

No. of Network Groups	Maximum No. of Voice Loops	No DGT Trunks in CCS/Loop		With DGT Trunks in CCS/Loop	
		560	500	540	485
1	24	13440	12000	<b>12960</b>	11640
2	48	26880	24000	25920	23280
3	72	40320	36000	38880	34920
4	96	53760	48000	51840	46560
5	120	67200	60000	64800	58200

**Note:** The maximum **CCS/loop** for any SL-1 is 600 **CCS/loop** when no **Digitone** Trunks are used or 580 **CCS/loop** when **Digitone** Trunks are used.



**Worksheet D**

One for the complete system at cutover, 2-year, and **5-year** intervals.

Customer: \_\_\_\_\_

Y e a r : \_\_\_\_\_

Address: \_\_\_\_\_

---

**Table D-1**

PE card calculations	CUT	2-YR	5-YR
No. of <u>ISDgtl C</u>	=		
No. of DTR	=		
No. of <u>500 TN</u> 4	=		
No. of <u>SL-1 TN</u> 4	=		
No. of Consoles	=		
No. of <u>CO/FX/ Wats/Private Link Trunks</u> 2	=		
No. of <u>2-Wire E&amp;M/DX/Paging Trunks</u> 2	=		

## Worksheet D continued

Table D-1 continued

PE card calculations

	CUT	2-YR	5-YR	.
No. of <u>Loop Signaling/DID Trunks</u> 2				
No. of <u>Dictation Trunks</u> 2				
No. of <u>Recorded Announcement Trunks</u> 4				
No. of AIOD Trunks				
No. of <u>4-Wire E&amp;M/DX Trunks</u> 2				
<b>TOTAL CARDS</b>				

## PE UEM calculations

Use the total cards required at 2 years to determine the number of PE UEMs to be provisioned at cutover.

$$\text{PE UEMs required} = \frac{\text{Total cards}}{8.5} \quad (\text{Round to next highest number})$$

Number of PE UEMs required at cutover \_\_\_\_\_

Table D-1 continued  
PE card calculations

	CUT	2-YR	5-YR
No. of Dgtl LC = Number of digital ports in service + number of TCM consoles x 6			
No. of Anlg LCs = <u>Number of analog ports in service</u> 16			
No. of Anlg M/W LCs = <u>Number of analog ports with Message Waiting feature in service</u> 16			
No. of XUT = <u>Total number of CO/DID/RAN/PAGE trunks</u> 8			
No. of XEMs = <u>Total number of E&amp;M/PAGE/Dictation trunks</u> 4			
<b>TOTAL CARDS</b>			

Notes: Do not configure more than one TCM console on one Dgtl LC for higher reliability. Try to spread Dgtl LCs supporting consoles over different XPE UEMs and different superloops for even higher reliability. Use paging trunks on XUT or XEM depending on what combination minimizes the total number of trunk cards required.

---

**Worksheet E**

One sheet for the complete system.

Customer: \_\_\_\_\_

D a t e : \_\_\_\_\_

Address: \_\_\_\_\_

\_\_\_\_\_

**UEM provisioning**

(1) Single network group system

CPU UEM \_\_\_\_\_ 1

PE UEM \_\_\_\_\_

(2) Multiple network group system

CPU UEM \_\_\_\_\_

Network UEM \_\_\_\_\_

PE UEM \_\_\_\_\_

---

**Worksheet F**

One sheet for the complete system.

Customer: \_\_\_\_\_

D a t e : \_\_\_\_\_

Address: \_\_\_\_\_

\_\_\_\_\_

### Conference loop requirements

Conference loops are provisioned according to the 2-year network loop requirements.

Conference Loop Required = \_\_\_\_\_

### Tone and Digit loop requirements

Tone and Digit loops are provisioned according to the 2-year network loop requirements.

Tone and Digit Loops Required = \_\_\_\_\_

### Estimated real time usage calculation

$$E R T U = \frac{\text{Total Line Load} \times 100 \times T}{150}$$

= Percent Utilization of CPU Real Time

---

**Worksheet F continued****Where:**

Total Line Load is the 2-year figure

T = the average processing time for a call in seconds;

use 0.6 for a single network group system, or  
0.24 for a multiple network group system

150 = the average holding time

2100 = the maximum **useable** real time of the CPU in seconds

**Worksheet G**

One sheet for the complete system.

Customer: \_\_\_\_\_

Date: \_\_\_\_\_

	<b>Items</b>	<b>Words</b>	<b>Total</b>
Fixed Amount of Storage Required			
<b>500 + 2500 TN</b>			
SL-1 TN			
Add-On Modules			
Network Groups			
Trunk Circuits			
Consoles			
Customer Groups			
Trunk Routes			
Network Loops (Excluding Conference)			
RPE Loops			

**Total** \_\_\_\_\_ (Include total from second worksheet)

**Total words** \_\_\_\_\_ (Include total words from second worksheet)

## Worksheet G continued

	Items	Words	Total
InterGroup Pairs			
Peripheral Signaling Cards			
Serial Data Interface Cards			
Tone and Digit Switch			
MF Senders			
Conference Card			
Digitone Receivers			
Call Registers			
Low Priority Input Buffers			
High priority Input Buffers			
500-Type Output Buffers			
SL-1 Type Output Buffer			

Total \_\_\_\_\_ (Add to first page total)

Total words \_\_\_\_\_ (Add to first page total words)



**Worksheet G continued**

Memory Card Code

OPC/NT ~ \_\_\_\_\_

Capacity

k words (1k = 1024 Words)

Unprotected Memory Cards Required

\_\_\_\_\_

Memory Card Addresses Required

\_\_\_\_\_



## Worksheet H

One sheet for the complete system.

Customer: \_\_\_\_\_

Date: \_\_\_\_\_

Table H-1

**Protected memory calculations**

	Items	Words	Total
Fixed Amount of Storage Required	1		
500 + 2500 TN			
SL-1 TN			
Add-On Modules			
Network Groups			
Trunk Circuits			
Consoles			
Customer Groups			
Trunk Routes			
Code Restricted Trunk Routes			
Network Loops (Excluding Conference)			
Digitone Receivers			

**Worksheet H continued**

**Total** \_\_\_\_\_ (Include total from third page)

**Add 10%** \_\_\_\_\_

**Total words** \_\_\_\_\_ (Include total words from third page)

Memory Card Code OPCNT

Capacity k words (1k = 1024 Words)

Protected Memory Cards Required \_\_\_\_\_

Memory Card Addresses Required \_\_\_\_\_

## Worksheet H continued

One sheet for the complete system.

Customer: \_\_\_\_\_

Date: \_\_\_\_\_

**Table H-1 continued**  
**Protected memory calculations**

	Items	Words	Total
Speed Call Head Table			
Speed Call Lists (10 Numbers)			
Speed Call Lists (50 Numbers)			
Tone and Digit Switch			
Conference Card			
History File			

**Total** \_\_\_\_\_ (Add to first page total)

**Add 10%** \_\_\_\_\_

**Total words** \_\_\_\_\_ (Add to first page total words)

### Worksheet I

One sheet for the complete system.

Customer: \_\_\_\_\_

Date: \_\_\_\_\_

#### Program store calculations

Program Name	Storage in k (1k = 1024 words)
Basic	
Overlay Area	
Read Only Memory	

**Total** = \_\_\_\_\_ k

**Total x 1024** = \_\_\_\_\_ words

---

**Worksheet I continued**

Memory Card Code

OPC/NT

Capacity

k words (1 k = 1024 Words)

Program Store Cards Required

\_\_\_\_\_

Memory Card Addresses Required

\_\_\_\_\_

---

**Worksheet J**  
**Equipment summary**

One sheet for the complete system.

Customer: \_\_\_\_\_

Date: \_\_\_\_\_

**Table J-I**  
**Equipment summary**

<b>Equipment summary</b>	<b>Quantity</b>	<b>Based on figure</b>
Line and Trunk Cards		Cutover
<b>Digitone</b> Receivers		<b>2 Year</b>
Unprotected Memory Cards		<b>2 Year</b>
Protected Memory Cards		<b>2 Year</b>
Conference Loops		<b>2 Year</b>
Tone and Digit <b>Loops</b>		2Year
Call Registers		<b>2 Year</b>
High Priority Input Buffers		Cutover

## Worksheet J continued

One sheet for the complete system.

Customer: \_\_\_\_\_

Date: \_\_\_\_\_

Table J-1 continued  
Equipment summary

Equipment summary	Quantity	Based on figure
Low Priority Input Buffers		Cutover
500-Type Output Buffers		Cutover
SL-1-Type Output Buffers		Cutover
Central Processing Units		Cutover
Peripheral UEMs		2 Year
Network Loops (Less Conf and TDS)		2 Year
Network Groups		2 Year



### Worksheet K

One sheet for the complete system.

Customer: \_\_\_\_\_

Date: \_\_\_\_\_

**Table K-1**  
Balancing network loops over network groups

Customer	Network Group 0	Network Group 1	Network Group 2	Network Group 3	Network Group 4

---

**Worksheet L**

One sheet for the complete system.

Customer: \_\_\_\_\_

Date: \_\_\_\_\_

**Load balancing**

Total system load = \_\_\_\_\_ c c s

Voice loops required = \_\_\_\_\_

PE UEMs required = \_\_\_\_\_

Average CCS per UEM =  $\frac{\text{Total system load CCS}}{\text{PE UEMs required}}$  = \_\_\_\_\_ c c s

Average CCS per Loop =  $\frac{\text{Total system load CCS}}{\text{Voice loops required}}$  = \_\_\_\_\_ c c s

Table L-I  
Load balancing

Loop number	UEMs assigned	CCS per loop	CCS per UEM

**Worksheet L continued**

One sheet for the complete system.

Customer: \_\_\_\_\_

Date: \_\_\_\_\_



**Table L-I**  
**Load balancing**

Loop number	UEMs assigned	CCS per loop	CCS per UEM



---

**Worksheet M**

One sheet for the complete system.

Customer: \_\_\_\_\_

Date: \_\_\_\_\_

**Card distribution**

Divide the total number of a card type by the total number of BE UEMs to arrive at a **cards-per-UEM** figure:

**Table M-1**  
**Card distribution**

<b>Pack type</b>	<b>Quantity</b>	<b>Total PE UEMs</b>	<b>Packs per UEM</b>

**Worksheet N**

One sheet for the complete system.

Customer: \_\_\_\_\_

Date: \_\_\_\_\_

**Table N-1**  
**Multiple Appearance Group (MAG) assignments**

<b>Loop number</b>	<b>Loop number</b>	<b>Loop number</b>	<b>Loop number</b>
MAG No. SL-1 TN 500 TN	MAG No. SL-1 TN 500 TN	MAG No. SL-1 TN <b>500TN</b>	MAG No. SL-1 TN <b>500TN</b>
MAG No. SL-1 TN <b>500TN</b>	MAG No. SL-1 TN 500 TN	MAG No. SL-1 TN <b>500TN</b>	MAG No. SL-1 TN 500 TN
MAG No. SL-1 TN 500 TN	MAG No. SL-1 TN 500 TN	MAG No. SL-1 TN <b>500TN</b>	MAG No. SL-1 TN <b>500TN</b>
MAG No. SL-1 TN <b>500TN</b>	MAG No. SL-1 TN <b>500TN</b>	MAG No. SL-1 TN <b>500TN</b>	MAG No. SL-1 TN <b>500TN</b>
SL-1 Packs _____ 500 P a c k s	SL - 1 P a c k s <b>500 P a c k s</b>	SL - 1 P a c k s <b>500 P a c k s</b>	SL - 1 P a c k s <b>500 P a c k s</b>

---

**-Worksheet 0**

One sheet for the complete system.

Customer: \_\_\_\_\_

Date: \_\_\_\_\_

**Station load balancing**

Total SL-1 TN to be assigned \_\_\_\_\_

Less number of SL-1 TN assigned to MAG • \_\_\_\_\_

Equals number of SL-1 TN not in MAG = \_\_\_\_\_

**TOTAL PE UEMs** = \_\_\_\_\_ Number of 500 TN not in  
 SL-1 TN not in MAG MAG assigned per UEM

TOTAL 500 TN to be assigned \_\_\_\_\_

Less number of 500 TN assigned to MAG • \_\_\_\_\_

Equals number of 500 TN not in MAG = \_\_\_\_\_

**TOTAL PE UEMs** = \_\_\_\_\_ Number of 500 TN not in  
 500 TN not in MAG MAG assigned per UEM

Worksheet ① continued

Total 2500 TN to be assigned \_\_\_\_\_

Less number of 2500 TN assigned to **MAG** - \_\_\_\_\_

Equals number of 2500 TN not in MAG = \_\_\_\_\_

**TOTAL PE UEMs** = \_\_\_\_\_  
2500 TN not in MAG

Number of 2500 TN not in  
MAG assigned per UEM

## -Worksheet P

Customer: \_\_\_\_\_

Date: \_\_\_\_\_

Table P-1  
Card to UEM assignment

	Type		Type	Total packs	CCS load
Position 1		Position 6			
Position 2		Position 7			
Position 3		Position 8			
Position 4		Position 9			
Position 5		Position 10			

Loop number \_\_\_\_\_ UEM number \_\_\_\_\_

Table P-2  
Card to UEM assignment

	Type		Type	Total packs	CCS load
Position 1		Position 6			
Position 2		Position 7			
Position 3		Position 8			
Position 4		Position 9			
Position 5		Position 10			

Loop number \_\_\_\_\_ UEM number \_\_\_\_\_



**Worksheet P continued**

Customer: \_\_\_\_\_

Date: \_\_\_\_\_

**Table P-3**  
Card to **UEM** assignment

	Type		Type	Total packs	CCS load
Position 1		Position 6			
Position 2		Position 7			
Position 3		Position 8			
Position 4		Position 9			
Position 5		Position 10			

Loop number \_\_\_\_\_ UEM number \_\_\_\_\_

**Table P-4**  
Card to **UEM** assignment

	Type		Type	Total packs	c c s load
Position 1		Position 6			
Position 2		Position 7			
Position 3		Position 8			
Position 4		Position 9			
Position 5		Position 10			

Loop number \_\_\_\_\_ UEM number \_\_\_\_\_

## -Worksheet Q

One sheet for each PE UEM in the system.

Date: \_\_\_\_\_

DN = Directory Number  
RTMB = Route Member Number

Loop number \_\_\_\_\_ UEM number \_\_\_\_\_ Group number \_\_\_\_\_

**Table Q-1**  
**TN assignment record**

Pack pos	Pack type	Pack CKT	DN	RTMB	CUST
1		0			
		1			
		2			
		3			
		4			
		5			
		6			
2		7			
		0			
		1			
		2			
		3			
		4			
		5			
3		6			
		7			
		0			
		1			
		2			
		3			
		4			
5					
		6			
		7			

Worksheet Q continued

Date: \_\_\_\_\_

DN = **Directory** Number  
 RTMB = Route Member Number

Loop number \_\_\_\_\_ UEM number \_\_\_\_\_ Group number \_\_\_\_\_

Table Q-1 continued  
 TN assignment record

Pack pos	Pack type	Pack CKT	DN	RTMB	CUST
4		0			
		1			
		2			
		3			
		4			
		5			
		6			
		7			
5		0			
		1			
		2			
		3			
		4			
		5			
		6			
		7			
6		0			
		1			
		2			
		3			
		4			
		5			
		6			
		7			

## Worksheet Q continued

Table Q-1 continued  
TN assignment record

Loop # \_\_\_\_ U E M # Grp # \_\_\_\_

IPack pos	Pack type	Pack CKT	DN	RTMB	CUST
7		0			
		1			
		2			
		3			
		4			
		5			
		6			
		7			
8		0			
		1			
		2			
		3			
		4			
		5			
		6			
		7			
9		0			
		1			
		2			
		3			
		4			
		5			
		6			
		7			
10		0			
		1			
		2			
		3			
		4			
		5			
		6			
		7			

**Worksheet R**  
**SL-1 system assignment plan**

Prepared by: \_\_\_\_\_

D a t e : \_\_\_\_\_

System: \_\_\_\_\_

Customer: \_\_\_\_\_

One sheet for each equipped voice loop.

Loop number \_\_\_\_\_

Group number \_\_\_\_\_

**UEMs equipped** \_\_\_\_\_

**Trunks working** \_\_\_\_\_

**Trunks equipped** \_\_\_\_\_

**Consoles** \_\_\_\_\_

**Digitone receivers** \_\_\_\_\_

**2500 TN** \_\_\_\_\_

**500 TN** \_\_\_\_\_

**SL-1 TN** \_\_\_\_\_

**MAG assigned** \_\_\_\_\_

**Load capacity** \_\_\_\_\_

**Recommended assignment plan** \_\_\_\_\_



**Worksheet S**  
**Multiple appearance group record**

Prepared by: \_\_\_\_\_

Date: \_\_\_\_\_

System: \_\_\_\_\_

Customer: \_\_\_\_\_

**Table S-1**  
**Multiple appearance group record**

MAG number	LP. number	EXT. number	stat. designator	Set type	Department



---

# Tables

---

<b>Tables</b>	<b>6-1</b>
Table 6-1 : Trunk Traffic	6-1
Table 6-2: Trunk Traffic	6-3
Table 6-3: <b>Digitone</b> Receiver Requirements	6-5
Table 6-4 : <b>Digitone</b> Receiver Requirements	6-7
Table 6-5: <b>Digitone</b> Receiver Requirements	6-9
Table 6-6: <b>Digitone</b> Receiver Requirements	6-1 1
Table 6-7: <b>Digitone</b> Receiver Requirements	6-1 3
Table 6-8: <b>Digitone</b> Receiver Requirements	6-15
Table 6-9: <b>Digitone</b> Receiver Requirements	6-17
Table 6-1 0: TDS and CONF Loop Requirements	6-19
Table 6-1 1: <b>Digitone</b> Receiver Provisioning	<b>6-20</b>



6-2 Tables

Table 6-1  
Trunk traffic (Poisson 1% blocking)

TRKS	CCS	TRKS	CCS	TRKS	CCS	TRKS	CCS	TRKS	CCS
1	0.4	31	703	61	1595	91	2530	121	3488
2	5.4	32	732	62	1626	92	2563	1 2 2	3520
3	15.7	33	760	63	1657	93	2594	123	3552
4	29.6	34	789	64	1687	94	2625	124	3594
5	46.1	35	818	65	1718	95	2657	125	3616
6	64	36	847	66	1749	96	2689	126	3648
7	84	37	876	67	1780	97	2721	127	3681
8	105	38	905	68	1811	98	2752	128	3713
9	126	39	935	69	1842	99	2784	129	3746
10	149	40	964	70	1873	100	2816	130	3778
11	172	41	993	71	1904	101	2847	131	3810
12	195	42	1023	72	1935	102	2879	132	3843
13	220	43	1052	73	1966	103	2910	133	3875
14	244	44	1082	74	1997	104	2942	134	3907
15	269	45	1112	75	2028	105	2974	135	3939
16	294	46	1142	76	2059	106	3006	136	3972
17	320	47	1171	77	2091	107	3038	137	4004
18	346	48	1201	78	2122	108	3070	138	4037
19	373	49	1231	79	2153	109	3102	139	4070
20	399	50	1261	80	2184	110	3135	140	4102
21	426	51	1291	81	2215	111	3166	141	4134
22	453	52	1322	82	2247	112	3198	142	4167
23	480	5 3	1352	83	2278	113	3230	143	4199
24	507	54	1382	84	2310	114	3262	144	4231
25	535	55	1412	85	2341	115	3294	145	4264
26	562	56	1443	86	2373	116	3326	146	4297
27	590	57	1473	87	2404	117	3359	147	4329
28	618	58	1504	88	2436	118	3391	148	4362
29	647	59	1534	89	2467	119	3424	149	4395
30	675	60	1565	90	2499	120	3456	150	4427

Note: For trunk traffic greater than 4427 ccs, allow 29.5 ccs/trunk.

Table 6-2  
Trunk traffic (Poisson 2% blocking)

TRKS	CCS	TRKS	CCS	TRKS	CCS	TRKS	CCS	TRKS	CCS
1	4	31	744	61	1659	91	2611	121	3581
2	7.9	32	773	62	1690	92	2643	122	3614
3	20.9	33	803	63	1722	93	2674	123	3647
4	36.7	34	832	64	1752	94	2706	124	3679
5	55.8	35	862	65	1784	95	2739	125	3712
6	76.0	36	892	66	1816	96	2771	126	3745
7	96.8	37	922	67	1817	97	2803	127	3777
8	119	38	952	68	1878	98	2838	128	3810
9	142	39	982	69	1910	99	2868	129	3843
10	166	40	1012	70	1941	100	2900	130	3875
11	191	41	1042	71	1973	101	2931	131	3810
12	216	42	1072	72	2004	102	2964	132	2941
13	241	43	1103	73	2036	103	2996	133	2974
14	267	44	1133	74	2067	104	3029	134	4007
15	293	45	1164	75	2099	105	3651	135	4039

—continued—

Table 6-2 continued  
Trunk traffic (Poisson 2% blocking)

TRKS	CCS	TRKS	CCS	TRKS	CCS	TRKS	CCS	TRKS	CCS
16	320	46	1194	76	2130	106	3094	136	4072
17	347	47	1125	77	2162	107	3126	137	4105
18	374	48	1255	78	2194	108	3158	138	4138
19	401	49	1286	79	2226	109	3190	139	4171
20	429	50	1317	80	2258	110	3223	140	4204
21	458	51	1348	81	2290	111	3255	141	4237
22	486	52	1374	82	2322	112	3288	142	4209
23	514	53	1352	83	2354	113	3321	143	4302
24	542	54	1441	84	2386	114	3353	144	4335
25	571	55	1472	85	2418	115	3386	145	4368
26	562	56	1503	86	2450	116	3418	146	4401
27	627	57	1534	87	2482	117	3451	147	4434
28	656	58	1565	88	2514	118	3483	148	4467
29	685	59	1596	89	3546	119	3516	149	4500
30	715	60	1627	90	2578	120	3548	150	4533

*Note: For trunk traffic greater than 4533 ccs, allow 30.2 ccs/trunk.*

**Table 6-3**  
**Digitone receiver requirements**

Number of digitone receivers	Maximum number of digitone lines	Digitone receiver load (CCS)	Number of digitone receivers	Maximum number of digitone lines	Digitone receiver load (CCS)
2	7	2	17	1181	319
3	33	9	18	1244	336
4	69	19	19	1348	364
5	120	33	20	1455	393
6	179	49	21	1555	420
7	249	68	22	1662	449
8	332	88	23	1774	479
9	399	109	24	1885	509
10	479	131	25	1988	537
11	564	154	26	2100	567
12	659	178	27	2211	597
13	751	203	28	2325	628
14	848	229	29	2440	659
15	944	255	30	2555	690
16	1044	282			

Nok: Refer to Section 3-15 for the Model assumptions for this table.

**Table 6-4**  
**Digitone receiver requirements**

<b>Number of digitone receivers</b>	<b>Maximum number of digitone line!</b>	<b>Digitone receiver load (CCS)</b>	<b>Number of digitone receivers</b>	<b>Maximum number of digitone lines</b>	<b>Digitone receiver load (CCS)</b>
<b>2</b>	<b>2</b>	<b>2</b>	<b>17</b>	<b>843</b>	<b>253</b>
<b>3</b>	<b>21</b>	<b>7</b>	<b>18</b>	<b>920</b>	<b>276</b>
<b>4</b>	<b>52</b>	<b>15</b>	<b>19</b>	<b>996</b>	<b>299</b>
<b>5</b>	<b>90</b>	<b>27</b>	<b>20</b>	<b>1076</b>	<b>323</b>
<b>6</b>	<b>134</b>	<b>40</b>	<b>21</b>	<b>1153</b>	<b>346</b>
<b>7</b>	<b>183</b>	<b>55</b>	<b>22</b>	<b>1233</b>	<b>370</b>
<b>8</b>	<b>235</b>	<b>71</b>	<b>23</b>	<b>1316</b>	<b>395</b>
<b>9</b>	<b>293</b>	<b>88</b>	<b>24</b>	<b>13%</b>	<b>419</b>
<b>10</b>	<b>353</b>	<b>107</b>	<b>25</b>	<b>1480</b>	<b>444</b>
<b>11</b>	<b>416</b>	<b>126</b>	<b>26</b>	<b>1563</b>	<b>469</b>
<b>12</b>	<b>483</b>	<b>145</b>	<b>27</b>	<b>1650</b>	<b>495</b>
<b>13</b>	<b>553</b>	<b>166</b>	<b>28</b>	<b>1733</b>	<b>520</b>
<b>14</b>	<b>623</b>	<b>187</b>	<b>29</b>	<b>1816</b>	<b>545</b>
<b>15</b>	<b>693</b>	<b>208</b>	<b>30</b>	<b>1903</b>	<b>571</b>
<b>16</b>	<b>770</b>	<b>231</b>			
<i>Note: Refer to Section 3 5 for the Mod assumptions for this table.</i>					

**Table 6-5**  
**Digitone receiver requirements**

<b>Number of digitone receivers</b>	<b>Maximum number of digitone lines</b>	<b>Digitone receiver load (CCS)</b>	<b>Number of digitone receivers</b>	<b>Maximum number of digitone lines</b>	<b>Digitone receiver load (CCS)</b>
2	5	2	17	862	319
3	22	9	18	908	336
4	50	19	19	983	364
5	87	33	20	1062	393
6	132	49	21	1135	420
7	180	68	22	1213	449
8	234	88	23	1294	479
9	291	109	24	1375	509
10	353	131	25	1451	537
11	415	154	26	1532	567
12	481	178	27	1613	597
13	548	203	28	1697	628
14	618	229	29	1781	659
15	689	255	30	1864	690
16	762	282			

Note: Refer to Section 3-15 for the Model assumptions for this table.

**Table 6-6**  
**Digitone receiver requirements**

Number of digitone receivers	Maximum number of digitone lines	Digitone receiver load (CCS)	Number of digitone receivers	Maximum number of digitone lines	Digitone receiver load (CCS)
2	4	2	17	683	253
3	18	7	18	745	276
4	41	15	19	808	299
5	72	27	20	872	323
6	109	40	21	935	346
7	148	55	22	1000	370
8	193	71	23	1067	395
9	240	88	24	1132	419
10	291	107	25	1200	444
11	340	126	26	1267	469
12	391	145	27	1337	495
13	448	166	28	1405	520
14	505	187	29	1472	545
15	562	208	30	1543	571
16	624	231			
<i>Note: Refer to Section 3-15 for the Model assumptions for this table.</i>					

**Table 6-7**  
**Digitone receiver load capacity in CCS**

Average holding time in seconds	6	7	8	9	10	11	12	13	14	15
Number of digitone receivers										
1	0	0	0	0	0	0	0	0	0	0
2	3	2	2	2	2	2	2	2	2	2
3	11	10	10	9	9	9	9	8	8	8
4	24	23	22	21	20	19	19	19	18	18
5	41	39	37	36	35	34	33	33	32	32
6	61	57	55	53	52	50	49	49	48	47
7	83	78	75	73	71	69	68	67	66	65
8	106	101	91	94	91	89	88	85	85	84
9	131	125	120	116	113	111	109	107	106	104
10	157	150	144	140	136	133	131	129	127	126
11	185	176	170	165	161	157	154	152	150	148
12	212	203	196	190	185	182	178	176	173	171
13	241	231	223	216	211	207	203	200	198	196
14	270	259	250	243	237	233	229	225	223	220
15	300	288	278	271	264	259	255	251	248	245
16	339	317	307	298	292	286	282	278	274	271
17	361	346	335	327	310	313	319	306	302	298
18	391	377	365	356	348	342	336	331	327	324
19	422	409	396	386	378	371	364	359	355	351
20	454	438	425	414	405	398	393	388	383	379

—continued—



Table 6-7 continued  
**Digitone receiver load capacity in CCS**

Average holding time in seconds	6	7	8	9	10	11	12	13	14	15
Number Of digitone receivers	0	0	0	0	0	0	0	0	0	0
21	487	469	455	444	435	427	420	415	410	406
22	517	501	487	475	466	456	449	443	438	434
23	550	531	516	504	494	487	479	472	467	562
24	583	563	547	535	524	515	509	502	497	491
25	615	595	579	566	555	545	537	532	526	521
26	647	628	612	598	586	576	567	560	554	548
27	680	659	642	628	618	607	597	589	583	577
28	714	691	674	659	647	638	628	620	613	607
29	746	724	706	690	678	667	659	651	644	637
30	779	758	738	723	709	698	690	682	674	668
31	813	792	771	755	742	729	719	710	703	696
32	847	822	805	788	774	761	750	741	733	726
33	882	855	835	818	804	793	781	772	763	756
34	913	889	868	850	836	825	812	803	795	787
35	947	923	900	883	867	855	844	835	826	818
36	981	957	934	916	900	886	876	866	857	850
37	1016	989	967	949	933	919	909	898	889	881
38	1051	1022	1001	982	966	951	938	928	918	912
39	1083	1055	1035	1015	999	984	970	959	949	941
40	1117	1089	1066	1046	1029	1017	1002	990	981	972

Table 6-8  
Digitone receiver load capacity in CCS

Average holding time in seconds	16	17	18	19	20	21	22	23	24	25
Number Of digitone receivers	0	0	0	0	0	0	0	0	0	0
1										
2	2	2	2	2	2	2	2	2	2	2
3	8	8	8	8	8	8	8	8	8	8
4	18	18	18	18	18	17	17	17	17	17
5	31	31	31	30	30	30	30	30	30	28
6	47	46	46	45	45	45	45	44	44	44
7	64	63	63	62	62	62	61	61	61	60
8	83	82	82	81	80	80	79	79	79	78
9	103	102	101	100	100	99	99	98	98	97
10	125	123	122	121	121	120	119	119	118	117
11	147	145	144	143	142	141	140	140	139	138
12	170	168	167	166	165	164	163	162	161	160
13	193	192	190	189	188	186	185	184	184	183
14	218	216	214	213	211	210	209	208	207	206
15	243	241	239	237	236	234	233	232	231	230
16	268	266	264	262	260	259	257	256	255	254
17	294	292	290	288	286	284	283	281	280	279
18	322	319	317	314	312	311	309	308	306	305
19	347	344	342	339	337	335	334	332	331	329
20	374	371	368	366	364	361	360	358	356	355

Table 6-8 continued  
**Digitone receiver load capacity in CCS**

Average holding time in seconds	16	17	18	19	20	21	22	23	24	25
Number of digitone receivers	0	0	0	0	0	0	0	0	0	0
21	402	399	396	393	391	388	386	385	383	381
22	431	427	424	421	419	416	414	412	410	409
23	458	454	451	448	445	442	440	438	436	434
24	486	482	478	475	472	470	467	465	463	461
25	514	510	506	503	500	497	495	492	490	488
26	544	539	535	532	529	526	523	521	518	516
27	573	569	565	561	558	555	552	549	547	545
28	603	598	594	590	587	584	581	578	576	573
29	631	626	622	618	614	611	608	605	602	600
30	660	655	651	646	643	639	636	633	631	628
31	690	685	680	676	672	668	665	662	659	656
32	720	715	710	705	701	698	694	691	688	686
33	751	745	740	735	731	727	724	721	718	715
34	782	776	771	766	761	757	754	750	747	744
35	813	807	801	796	792	788	784	780	777	774
36	841	835	829	824	820	818	814	810	807	804
37	872	865	859	854	849	845	841	837	834	831
38	902	896	890	884	879	875	871	867	863	860
39	934	927	921	914	909	905	901	897	893	890
40	965	952	952	945	940	936	931	927	923	920

Table 6-9  
**Digitone** receiver requirements  
(Poisson 0.1% blocking)

Number of digitone receivers	Digitone receiver load (CCS)	Number of digitone receivers	Digitone receiver load (CCS)
1	0	26	469
2	2	27	495
3	7	28	520
4	15	29	545
5	27	30	571
6	40	31	597
7	55	32	624
8	71	33	650
9	88	34	676
10	107	35	703
11	126	36	729
12	145	37	756
13	166	38	783
14	187	39	810
15	208	40	837
16	231	41	865
17	253	42	892
18	276	43	919
19	299	44	947
20	323	45	975
21	346	46	1003
22	370	47	1030
23	395	48	1058
24	419	49	1086
25	444	50	1115

6-14 Tables

**Table 6-10**  
**Network group capacities**

Number of network groups	Maximum number of voice loops	No figitonetrunks 744 / 560 / 500 CCS per loop	Digitone trunks 720 / 540 / 485 CCS per loop
1	24	17850 / 13440 / 12000	17280 / 12960 / 11640
2	48	35700 / 26880 / 24000	34560 / <b>25920</b> / 23280
3	72	53550 / <b>40320</b> / <b>36000</b>	51840 / <b>38880</b> / 34920
4	96	71400 / 53760 / 48000	<b>69120</b> / <b>51840</b> / <b>46560</b>
5	120	89250 / <b>67200</b> / 60000	86400 / 64800 / 58200

**Note:** This table is based on an 85% utilization level. The 17850 CCS limit used above is based on **CCS/Loop** figures of 744 **CCS/Loop** with no **Digitone** trunks and 720 **CCS/Loop** with **Digitone** trunks. This constitutes an 85% utilization level of the maximum **CCS/Loop** of the current system which is 875 **CCS/Loop** with no **Digitone** trunks and 848 **CCS/Loop** with **Digitone** trunks and with the use of a Superloop Network Card.

**Table 6-10**  
**TDS and CONF loop requirements**

<b>Network loops required at 2 years</b>	<b>Tone and Digit Switch loops required</b>	<b>Conference loops required</b>
<b>1-12</b>	<b>1</b>	<b>1</b>
<b>13-24</b>	<b>2</b>	<b>2</b>
<b>25-36</b>	<b>3</b>	<b>3</b>
<b>37-48</b>	<b>4</b>	<b>4</b>
<b>49-60</b>	<b>5</b>	<b>5</b>
<b>61-72</b>	<b>6</b>	<b>6</b>
<b>73-84</b>	<b>7</b>	<b>7</b>
<b>85-96</b>	<b>8</b>	<b>8</b>
<b>97-108</b>	<b>9</b>	<b>9</b>
<b>m-120</b>	<b>10</b>	<b>10</b>

Table 6-11

**Digitone** receiver provisioning  
(assumes 1 l-second holding time)

DTR CCS	DTR ports	DTR CCS	DTR ports
1-2	2	730-761	32
3-9	3	762-793	33
10-19	4	794-825	34
20-34	5	826-856	35
35-50	6	857-887	36
51-69	7	888-919	37
70-89	8	920-951	38
90-111	9	952-984	39
<del>114-122</del>	10	985-1017	40
134-157	11	1018-1050	41
158-182	12	1051-1084	42
183-207	13	1085-1118	43
208-233	14	1119-1153	44
234-259	15	1154-1188	45
260-286	16	1189-1223	46
287-313	17	1224-1258	47
314-342	18	1259-1293	48
343-371	19	1294-1329	49
<del>374-398</del>	20	1330-1365	50
399-427	21	1366-1400	51
428-456	22	1401-1435	52
457-487	23	1436-1470	53
488-515	24	1471-1505	54
516-545	25	1506-1540	5 5 1
546-576	26	1541-1575	56
577-607	27	1576-1610	57
608-638	28	1611-1645	58
639-667	29	1646-1680	59
668-698	30	1681-1715	60
699-729	31	1716-1750	61
—continued—			

**Table 6-11 continued**  
**Digitone receiver provisioning**  
 (assumes 11-second holding time)

DTR CCS	DTR ports	DTR CCS	DTR ports
1751-1785	62	2871-2905	94
1786-1820	63	2906-2940	95
1821-1855	64	2941-2975	96
1856-1890	65	2976-3010	97
1891-1925	66	3011-3045	98
1926-1960	67	3046-3080	99
1961-1995	68	3081-3115	100
1996-2030	69	3116-3150	101
2031-2065	70		
2066-2100	71		
2101-2135	72		
2136-2170	73		
2171-2205	74		
2206-2240	75		
2241-2275	76		
2276-2310	77		
2311-2345	78		
2346-2380	79		
2381-2415	80		
2416-2450	81		
2451-2485	82		
2486-2520	83		
2521-2555	84		
2556-2590	85		
2591-2625	86		
2626-2660	87		
2661-2695	88		
2696-2730	89		
2731-2765	90		
2766-2800	91		
2801-2835	92		
2836-2870	93		



SL-1

## **System options 21, 51,61, 71**

System engineering

Copyright © 1990 Northern Telecom  
All rights reserved.  
Information subject to change without notice.  
Release 1.0  
Standard  
January 29, 1990  
Printed in U.S.A.



SL-1

# Generic XI 1

Memory calculations

Standard, release 15

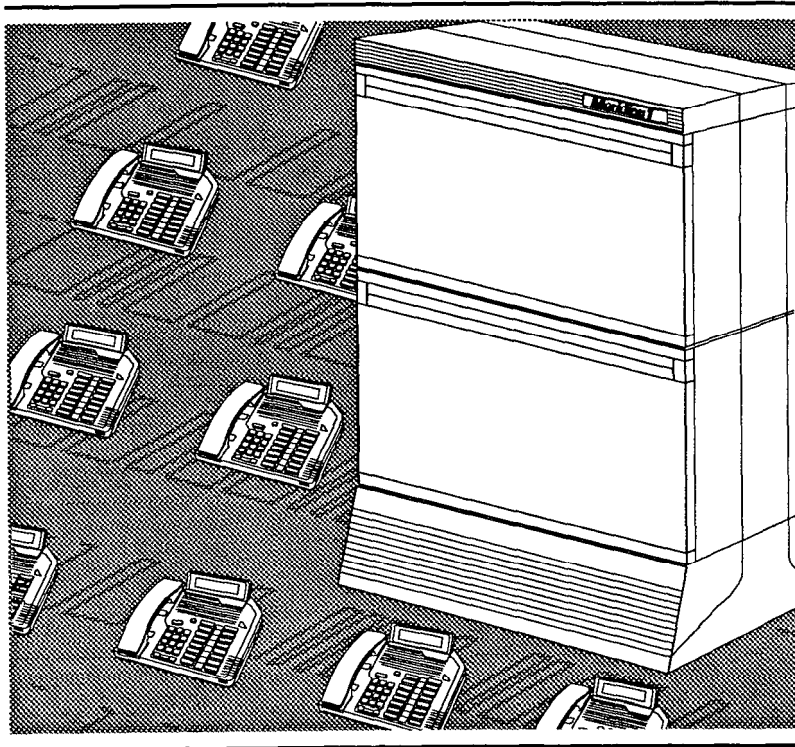





---

SL-1

# Generic XI 1

## Memory calculations

---

Publication number: 553-2201-151 Appendix 1

Product release: XI 1 release 15

Document release: 1 .0

Document status: Standard

Date: December **20, 1989**

---



© 1984 Northern Telecom  
All rights reserved.

---

# Revision history

---

## December 1989

Standard, release 1.0. This Publication is reissued as the Standard version for Relaes 15. Changes are marked with **R15**.

---

# Contents

---

<b>General</b>	<b>1</b>
<hr/>	
<b>Memory description</b>	<b>3</b>
Memory Generic 711 (S and MS)	5
Memory Generics 811 and 911 (N and XN)	5
Memory Generics 1011 (ST)	5
Memory Generics 1111, 1211, and 1311 (NT, XT, and RT)	5
Templates	6
<hr/>	
<b>Memory calculations</b>	<b>9</b>
Package dependencies	10
Program store requirements	11
Unprotected data storage requirements	85
Protected data storage requirements	115
<hr/>	
<b>List of terms</b>	<b>163</b>
<hr/>	



---

## General

---

This Appendix provides memory information relating to the SL-1 Integrated Services Network (ISN).

**Engineering and assigning of equipment** (553-2201-151) provides provisioning information and the associated data worksheets for a complete system. For Generic XI 1, **Engineering and assigning of equipment (553-2201-151)** directs the user to this Appendix for specific memory calculation information. Apply this information in worksheets G, H, I of that document for the machine types in Table 1.

Use these numbers to identify machine types in the following tables.

Note : The memory calculations for the RT (13 11) are the same as-for NT(1111).

**Table 1**  
**Machine type designators**

Machine type		Code number	System option
MS/S	=	711	
N	=	811	
XN	=	911	
ST	=	1011	21
NT	=	1111	<b>51/61</b>
XT	=	1211	71
RT	=	1311	





---

## Memory description

---

Software and office data are stored in a read/write Random Access Memory (RAM). The RAM is organized into modules of **128K, 192K, 256K, 512K** or 768K by **16-bit** words, or 24-bit words for NT, RT, and XT machines in Release 12 and later. Memory size depends on the features programmed into the machine and the number and type of stations served. The memory module pack(s) are mounted in the CE shelf. The following table shows the valid hardware configuration for the various SL-1 systems.

Release 15 introduces other System Options, whose memory calculations coincide with the following current machine types:

- System option 21 has the **same memory** capacity as the 1011 machine **(ST) type** ---
- System options 51, and 61 have the same memory capacity as the 1111 machine (NT) type
- System option 71 has the same memory capacity as the 1211 machine **(XT) type**

**Table 2**  
**QPC memory module packs per system-**

Memory size	MS/S	N	XN	NT/RT	XT	ST
128K	1 - 478		<b>1-479</b>		<b>1 - 479</b>	
192K	1 - 423		1-426		1 - 426	
256K	2 - 478		2-479		2-479	
	OR					
	1 - 674					
320K		1-426	1 - 478			
		+	+			
		1 - 479	<b>1- 479</b>			
384K		2-426	2-426			
512K		1 - 672	1 - 672			1 - 673
576K			3-426			
768K			4 - 426	1 - 583	1 - 583	
1536K				1 - 583	2 - 583	
2304K						3 - 583

Note : **1K** = 1024 words. Storage capacity of the:

- **QPC423** memory circuit pack is 192 x 1024 or 196,608 words
- **QPC426** memory circuit pack is 192 x 1024 or 196,608 words
- **QPC478** memory circuit pack is 128 x 1024 or 131,072 words
- **QPC479** memory circuit pack is 128 x 1024 or 13 1,072 words
- **QPC583** memory circuit pack is 768 x 1024 or 786,432 words, with **25-bit** words for NT and XT machines
- **QPC672** memory circuit pack is 512 x 1024 or 524,288 words
- **QPC673** memory circuit pack is 512 x 1024 or 524,288 words
- **QPC674** memory circuit pack is 256 x 1024 or 262,144 words

## Memory Generic 711 (S and MS)

The memory requirements for a Generic 7 11 system consists of a Read Only Memory (ROM) circuit pack and RAM circuit pack(s). The memory system is divided into pages.

The unprotected and protected data stores are usually assigned to pages 0 and 1.

The bottom 8K words of page 2 are replaced with the QPC486 ROM pack. The remaining top words of page 2 are assigned to program store.

Page 3 (Input/Output memory) is not assigned to a QPC478 module and page 4 is not used.

Additional pages of program store are provided as required, by RAM pack addition or rearrangement.

Configuration Overlay LD 17 is used to assign the RAM type or combination of types for data and program store to a system (see 553-3001-400).

## Memory Generics 811 and 911 (N and XN)

Software and office data for Generics 8 11 and 9 11 are stored in a RAM (as for Generic 7 11) except that QPC426 and/or QPC479 modules (or a QPC672) are used.

The ROM for Generic 8 11 is contained in a QPC486 pack while the ROM for Generic 9 11 is part of the QPC443 Control and Timing pack.

## Memory Generics 1011 (ST)

Software and office data for Generic 1011 system are stored in a RAM (as for Generic 7 11) except that QPC673 (with error correction) is used.

The ROM for Generic 1011 is contained in QPC717 ROM pack which connects to the QPC687 CPU pack.

## Memory Generics 1111, 1211, and 1311 (NT, XT, and RT)

Software and office data for Generic 1111, 1211, and 13 11 systems are stored in a RAM (as for Generic 711) except that QPC583 modules, with 24-bit addressing, are used.

The ROM for Generic 1111; 1211, and 13 11 is contained in a QPC579 CPU Function Unit.

## Templates

A template is a map of the pattern of keys/features assigned to a telephone. The protected data structure for the SL- 1 **NE-500/2500** and digital telephones is based on the concept of shared templates. For example, if two or more telephones have identical key/feature layouts, then the data regarding this layout is contained in a single template, thereby reducing the storage required for data description.

The operation of the template mechanism is internal and is transparent to the user. Templates are created automatically either by service change programs or by the sysload program at system startup. The data print program (Overlay 20) of 553-3001-400 has been extended to assist in optimizing template usage. The program can print:

- individual templates or all templates in the system.
- the number of telephones using a particular template.
- the Terminal Numbers (TNS) using a template.
- the total number of templates defined and the number of templates used by at least one telephone.

**Note :** A large number of telephones clustered around a relative small number of templates indicates efficient use of templates.

When data is entered into the system, use the following guidelines to maximize the protected memory savings provided by the template mechanisms.

- (a) If two or more telephones have the same functions defined, they should, if possible, have the same key/feature layout assigned. This ensures that all such telephones and add-on modules share the same template.
- (b) For telephones that have the same functions defined but their auto-dial and/or call-forward features have different number sizes, it is less expensive (in terms of memory) to make the sizes of the numbers equal rather than assign the telephones to different templates. The rule to be used is that a new template requires at least 12 words of protected data for SL-1 telephone sets and four words for **500/2500** telephones, whereas four extra digits use only 1 word.

- (c) Use Overlay 20 of **553-3001-400** to **maintain** a current list of all templates defined in the system. Consult this list whenever service change of telephones is to be performed.



Page



---

## Memory calculations

---

The memory requirement for XI 1 Generic must be calculated individually using the following tables:

Table	Storage
3	Software Program
4	Unprotected Data
5	Protected Data

Record the memory requirements on worksheets G, H and I and add **this** data to the other completed main practice worksheets to compile the total provisioning data for the SL- 1 system.

*Note:* The memory requirement figures shown in the tables are based on the following software releases:

711	Releases 4 through 13
811	Releases 4 through 14
911	Releases 4 through 14
1011	Releases 9 through 15
<b>1111/1211</b>	Releases 8 through 15
1311	Releases 12 through 15

*Note I:* **711, 811** and 911 Release 6 information is included in Release 7.



**Note 2:**The memory calculations for the RT (1311) machine are the same as for the NT (1111) machine type.

The absence of Generic release indicator R4, **R5**, or R7 in **the Version** column indicates **the** storage words for **the** associated program applies to all Generic releases.



## Package dependencies

Each Generic contains a basic feature group (always provided) to which optional features can be added. For a complete list of the packages available and their related package dependencies, refer **to Equipment identification and ordering (U.S.) (553-2201-153)**.



**Table 3**  
**Software program storage requirements**

<b>Program</b> <b>(1K = 1024 words)</b>	<b>Version</b>	<b>Storage in Ks</b>	<b>Comments</b>
Resident (Basic)	711 R4	73.88	
	711 R5	77.04	
	711 R7	85.59	
	711 <b>R8</b>	87.61	
	711 R9	90.24	
	711 <b>R10</b>	96.70	
	711 R12	112.74	
	711 R13	122.62	
	811 R4	77.15	
	811 R5	81.96	
	811 R7	89.67	
	811 <b>R8</b>	91.10	
	<b>811/1011</b> R9	95.31	
	<b>811/1011</b> <b>R10</b>	102.02	
	<b>811/1011</b> R12	116.75	
	<b>811/1011</b> R13	126.90	
	<b>811/1011</b> R14	136.36	
	911 R4	75.76	
	911 R5	81.65	
	911 R7	89.30	
	911 <b>R8</b>	90.62	
	911 R9	92.51	
	911 <b>R10</b>	73.53	
	911 R12	111.03	
	911 R13	121.59	
	911 R14	136.06	
	1011 R15	158.77	
	<b>1111/1211</b> <b>R8</b>	68.46	
	<b>1111/1211</b> R9	70.02	
	<b>1111/1211</b> <b>R10</b>	73.53	
	<b>1111/1211</b> R12	84.23	
	<b>1111/1211</b> R13	87.84	
	<b>1111/1211</b> R14	94.62	
<b>1111/1211</b> R15	122.20		

— continued —

**Table 3**  
**Software program storage requirements (continued)**

Program (1K = 1024 words)	Version	Storage in Ks	Comments
Read/Write Firmware	711 R4-10	0.74	(Note 1)
	711 R12-13	0.36	
	811 R4	0.34	
	811 R5	0.35	
	811 R7-8	0.35	
	811/1011 R9-10	0.39	
	811/1011 R12-15	0.55	
	911 R4	0.40	
	911 R5	0.77	
	911 R7-10	0.77	
	911 R12-14	Note 1	
	1111/1211 R8-10	0.96	
	1111/1211 R12-15	Note 1	
	— continued —		

**Table 3**  
**Software program storage requirements (continued)**

<b>Program (1K = 1024 words)</b>	<b>Version</b>	<b>Storage in Ks</b>	<b>Comments</b>
Overlay Area	711 R4	10.58	
	711 R5	15.74	
	711 R7	16.46	
	711 R8	16.92	
	711 R9	16.96	
	711 R10	17.12	
	711 R12	18.07	
	711 R13	10.75	
	811 R4	11.00	
	811 R5	15.58	
	811 R7	16.46	
	811 R8	16.94	
	811/1011 R9	17.42	
	811/1011 R10	17.43	
	811/1011 R12	18.07	
	811/1011 R13	10.75	
	811/1011 R14-15	20.51	
	911 R4	11.00	
	911 R5	15.58	
	911 R7	16.46	
	911 R8	16.94	
	911 R9	17.42	
	911 R10	17.43	
	911 R12	18.07	
	911 R13	25.41	
	911 R14	20.51	
	1111/1211 R8	16.46	
	1111/1211 R9	17.42	
	1111/1211 R10	26.14	
	1111/1211 R12	27.10	
	1111/1211 R13	10.60	
	1111/1211 R14-15	30.76	

— continued —

14 Memory calculations

Table 3  
Software program storage requirements (continued)

<b>Program (1K = 1024 words)</b>	<b>Version</b>	<b>Storage in Ks</b>	<b>Comments</b>
OPTF	711, 811, 911, 1011, 1111, 1211	0	All Releases
	1011 R15	17.67	
	1111/1211	12.58	
CUST	711, 811, 911, 1011, 1111, 1211	0	All Releases
	1011 R15	9.19	
	1111/1211 R15	6.38	
AIOD	711 R4-12	0.88	
	711 R13	0.91	
	811 R4-8	0.88	
	811/1011 R9-12	0.88	
	811/1011 R13-15	0.91	
	911 R4-5, 8-12	0.87	
	911 R7	0.86	
	911 R13-14	0.90	
	1111/1211 R8-12	0.65	
	1111/1211 R13-15	0.66	

— continued —

Table 3  
Software program storage requirements (continued)

Program (1K = 1024 words)	Version	Storage in Ks	Comments
CDR	711 R4	1.77	
	711 R5	1.80	
	711 R7	1.94	
	711 R8	1.99	
	711 R9	2.05	
	711 R10	2.20	
	711 R12	2.38	
	711 R13	2.47	
	811 R4	1.77	
	811 R5	1.79	
	811 R7	1.94	
	811 R8	1.98	
	811/1011 R9	2.05	
	811/1011 R10	2.20	
	811/1011 R12	2.38	
	811/1011 R13-14	2.47	
	911 R4	1.74	
	911 R5	1.77	
	911 R7	1.91	
	911 R8	1.95	
	911 R9	2.02	
	911 R10	2.17	
	911 R12	2.35	
	911 R13-14	2.45	
	1011 R15	2.48	
	1111/1211 R8	1.50	
	1111/1211 R9	1.55	
	1111/1211 R10	1.67	
	1111/1211 R12	1.80	
	1111/1211 R13-14	1.75	
	1111/1211 R15	1.76	

continued

Table 3  
Software program storage requirements (continued)

Program (1K = 1024 words)	Version	Storage in Ks	Comments
CDR TTY	711 R4	0.56	
	711 R5	0.57	
	711 R7	0.59	
	711 R8	0.71	
	711 R9	0.72	
	711 R10	0.99	
	711 R12	1.07	
	711 R13	1.16	
	811 R4, 5	0.56	
	811 R7	0.59	
	811 R8	0.71	
	811 R9	0.72	
	811 R10	0.99	
	811/1011 R12	1.07	
	811/1011 R13-15	1.16	
	911 R4, 5	0.56	
	911 R7	0.59	
	911 R8	0.70	
	911 R9	0.72	
	911 R10	0.98	
	911 R12	1.06	
	911 R13-14	1.14	
	1111/1211 R8	0.54	
	1111/1211 R9	0.55	
	1111/1211 R10	0.76	
	1111/1211 R12	0.82	
	1111/1211 R13-15	0.83	

--- continued ---

**Table 3**  
**Software program storage requirements (continued)**

Program (1K = 1024 words)	Version	Storage in Ks	Comments
CDR CLNK	711 R4-5	0.56	
	711 R7-9	0.59	
	711 R10	0.66	
	711 R12	0.69	
	711 R13	0.81	
	811 R4-5	0.56	
	811 R7-8	0.59	
	811/1011 R9	0.59	
	811/1011 R10	0.66	
	811/1011 R12	0.69	
	811/1011 R13	0.81	
	811/1011 R14-15	0.89	
	911 R4	0.56	
	911 R5	0.57	
	911 R7-9	0.59	
	911 R10	0.66	
	911 R12	0.70	
	911 R13	0.82	
	911 R14	0.90	
	1111/1211 R8-9	0.46	
	1111/1211 R10	0.51	
	1111/1211 R12	0.53	
	1111/1211 R13	0.58	
1111/1211 R14-15	0.64		

— continued —



**Table 3**  
**Software program storage requirements (continued)**

<b>Program</b> (1K = 1024 words)	<b>Version</b>	<b>Storage in Ks</b>	<b>Comments</b>
<b>RAN</b>	<b>711 R4</b>	<b>1.34</b>	
	<b>711 R5</b>	<b>1.34</b>	
	<b>711 R7-8</b>	<b>1.36</b>	
	<b>711 R9</b>	<b>1.41</b>	
	<b>711 R10-12</b>	<b>1.49</b>	
	<b>711 R13</b>	<b>1.55</b>	
	<b>811 R4</b>	<b>1.33</b>	
	<b>811 R5</b>	<b>1.34</b>	
	<b>811 R7-8</b>	<b>1.36</b>	
	<b>811/1011 R9</b>	<b>1.40</b>	
	<b>811/1011 R10-12</b>	<b>1.49</b>	
	<b>811/1011 R13</b>	<b>1.55</b>	
	<b>811/1011 R14</b>	<b>1.54</b>	
	<b>911 R4-5</b>	<b>1.31</b>	
	<b>911 R7</b>	<b>1.36</b>	
	<b>911 R8</b>	<b>1.34</b>	
	<b>911 R9</b>	<b>1.38</b>	
	<b>911 R10</b>	<b>1.46</b>	
	<b>911 R12</b>	<b>1.47</b>	
	<b>911 R13-14</b>	<b>1.53</b>	
	<b>1011 R15</b>	<b>1.60</b>	
	<b>1111/1211 R8</b>	<b>1.03</b>	
	<b>1111/1211 R9</b>	<b>1.07</b>	
	<b>1111/1211 R10</b>	<b>1.12</b>	
	<b>1111/1211 R11</b>	<b>1.13</b>	
	<b>1111/1211 R13-14</b>	<b>1.11</b>	
	<b>1111/1211 R14</b>	<b>1.15</b>	

— continued —

**Table 3**  
**Software program storage requirements (continued)**

Program (1K = 1024 words)	Version	Storage in Ks	Comments
TAD	711 R4-5	0.71	
	711 R7-12	0.72	
	711 R13	0.76	
	811 R4-5	0.71	
	811 R7-8	0.72	
	811/1011 R9-12	0.72	
	811/1011 R13-15	0.76	
	911 R4-5	0.72	
	911 R7-12	0.73	
	911 R13-14	0.77	
	1111/1211 R8-12	0.54	
	1111/1211 R13-15	0.56	
DNDI	711 R4-9	0.39	
	711 R10	0.40	
	711 R12	0.42	
	711 R13	0.40	
	811 R4-8	0.39	
	811/1011 R9	0.39	
	811/1011 R10	0.40	
	811/1011 R12	0.42	
	811/1011 R13	0.40	
	811/1011 R14	0.42	
	911 R4-9	0.38	
	911 R10	0.39	
	911 R12	0.41	
	911 R13	0.39	
	911 R14	0.41	
	1011 R15	0.43	
	1111/1211 R8-10	0.29	
	1111/1211 R12	0.30	
	1111/1211 R13	0.28	
	1111/1211 R14	0.30	
1111/1211 R15	0.30		

— continued —

Table 3  
Software program storage requirements (continued)

Program (1K = 1024 words)	Version	Storage in Ks	Comments
EES	711 R4	0.60	
	711 R5	0.79	
	711 R7	0.76	
	711 R8	0.75	
	711 <b>R9</b>	0.79	
	711 <b>R10</b>	0.81	
	711 R12	0.83	
	711 R13	0.87	
	811 R4	0.60	
	811 R5	0.79	
	811 <b>R7-8</b>	0.76	
	811/1011 <b>R9</b>	0.81	
	811/1011 <b>R10</b>	0.83	
	811/1011 R12	0.85	
	811/1011 R13	0.89	
	811/1011 R14	0.91	
	911 R4	0.60	
	911 R5	0.78	
	911 <b>R7-8</b>	0.75	
	911 <b>R9</b>	0.80	
	911 <b>R10</b>	0.82	
	911 R12	0.84	
	911 R13	0.88	
	911 R14	0.90	
	1011 R15	1.00	
	1111/1211 R8	0.54	
	1111/1211 <b>R9</b>	0.58	
	1111/1211 <b>R10</b>	0.59	
	1111/1211 <b>R12-13</b>	0.61	
	1111/1211 R14	0.63	
1111/1211 R15	0.69		
<b>INTR</b>	711, 811, 911, 1011, 1111, 1211	0	All Releases.

— continued —

**Table 3**  
**Software program storage requirements (continued)**

<b>Program</b> <b>(1K = 1024 words)</b>	<b>Version</b>	<b>Storage in Ks</b>	<b>Comments</b>
ANI	711 R4-9	1.54	
	711 R10	1.56	
	711 R12	1.59	
	711 R13	1.65	
	811 R4-8	1.53	
	81 1/1011 R9	1.53	
	811/1011 R10	1.55	
	81 1/1011 R12	1.58	
	811/1011 R13	1.64	
	811/1011 R14	1.66	
	911 R4	1.52	
	911 R5	1.52	
	911 R7-9	1.51	..
	911 R10	1.53	
	911 R12	1.57	
	911 R13	1.62	
	911 R14	1.64	
	1011 R15	1.74	
	1111/1211 R8-9	1.17	---
	1111/1211 R10	1.19	
	1111/1211 R12	1.21	
	1111/1211 R13	1.19	
	1111/1211 R14	1.21	
1111/1211 R15	1.26		

— continued —

**Table 3**  
**Software program storage requirements (continued)**

<b>Program</b> <b>(1K = 1024 words)</b>	<b>Version</b>	<b>Storage in KS</b>	<b>Comments</b>
ANIR	711 R4-12	0.20	
	711 R13	0.22	
	811 R4-8	0.20	
	811/1011 R9-12	0.20	
	811/1011 R13-15	0.22	
	911 R4-12	0.19	
	911 R13-14	0.22	
	1111/1211 R8-12	0.16	
	1111/1211 R13	0.17	
	1111/1211 R15	0.18	
— continued —			

Table 3  
Software program storage requirements (continued)

Program (1K = 1024 words)	Version	Storage in Ks	Comments
<b>BRTE</b>	711 R4	4.95	
	711 R5	5.48	
	711 R7	5.61	
	711 R8	5.68	
	711 R9	5.74	
	711 R10	5.86	
	711 R12	6.81	
	711 R13	7.00	
	811 R4	4.95	
	811 R5	5.47	
	811 R7	5.61	
	811 R8	5.68	
	811/1011 R9	5.74	
	811/1011 R10	5.86	
	811/1011 R12	6.81	
	811/1011 R13	7.00	
	811/1011 R14	7.19	
	911 R4	4.87	
	911 R5	5.39	
	911 R7	5.52	
	911 R8	5.59	
	911 R9	5.65	
	911 R10	5.77	
	911 R12	6.71	
	911 R13	6.93	
	911 R14	7.12	
	1011 R15	7.86	
	1111/1211 R8	6.34	
	1111/1211 R9	4.46	
	1111/1211 R10	4.55	
	1111/1211 R12	5.30	
	1111/1211 R13	5.01	
	1111/1211 R14	5.15	
	1111/1211 R15	5.63	

continued

**Table 3**  
**Software program storage requirements (continued)**

Program (1K = 1024 words)	Version	Storage in Ks	Comments
RPE	711 R4-9	0.99	
	711 R10-12	1.00	
	711 R13	1.02	
	811 R4-8	1.00	
	811/1011 R9	1.00	
	811/1011 R10-12	1.01	
	811/1011 R13	1.03	
	811/1011 R14-15	1.02	
	911 R4-9	0.98	
	911 R10-12	1.00	
	911 R13-14	1.01	
	1111/1211 R8-9	0.77	
	1111/1211 R10-12	0.78	
	1111/1211 R13-156	0.74	
DNDG	711 R4-12	0.47	
	711 R13	0.49	
	811 R4-8	0.47	
	811/1011 R9-12	0.47	
	811/1011 R13-15	0.49	
	911 R4-12	0.46	
	911 R13	0.36	
	911 R14	0.49	
	1111/1211 R8-12	0.36	
1111/1211 R13-15	0.35		

— continued —

**Table 3**  
**Software program storage requirements (continued)**

<b>Program</b> <b>(1K = 1024 words)</b>	<b>Version</b>	<b>Storage in Ks</b>	<b>Comments</b>
MSB	711 R4-5	0.08	
	711 R7-12	0.10'	
	711 R13	0.13	
	811 R4-5	0.08	
	811 R7-8	0.10	
	811/1011 R9-12	0.10	
	811/1011 R13	0.13	
	811/1011 R14	0.19	
	911 R4-5	0.08	
	911 R7-9	0.09	
	911 R10-12	0.10	
	911 R13	0.13	
	911 R14	0.19	
	1011 R15	0.21	
	1111/1211 R8-12	0.07	
	1111/1211 R13	0.09	
	1111/1211 R14	0.13	
1111/1211 R15	0.15		
--- continued ---			---



**Table 3**  
**Software program storage requirements (continued)**

<b>Program</b> (1K = 1024 words)	Version	Storage in <b>Ks</b>	Comments
ss25	711 R8	0.61	
	711 <b>R9-10</b>	0.62	
	711 R12	0.64	
	711 R13	0.67	
	811 R8	0.61	
	<b>811/1011 R9-10</b>	0.62	
	<b>811/1011 R12</b>	0.64	
	<b>811/1011 R13</b>	0.67	
	81 <b>1/1011 R14</b>	0.72	
	911 <b>R4-5, 8-10</b>	0.61	
	911 R7	0.60	
	911 R12	0.63	
	911 R13	0.66	
	911 R14	0.71	
	1011 <b>R15</b>	0.96	
	<b>1111/1211 R8-10</b>	0.49	
	<b>1111/1211 R12</b>	0.50	
	<b>1111/1211 R13</b>	0.49	
	111 <b>1/1211 R14</b>	0.53	
	<b>1111/1211 R15</b>	0.71	

— continued —

**Table 3**  
**Software program storage requirements (continued)**

<b>Program</b> <b>(1K = 1024 words)</b>	<b>Version</b>	<b>Storage in Ks</b>	<b>Comments</b>
DDSP	711 R4	1.81	
	711 <b>R5</b>	1.82	
	711 R7	2.10	
	711 R8	2.11	
	711 R9	2.47	
	711 <b>R10</b>	2.98	
	711 <b>R12-13</b>	3.37	
	811 R4	1.81	
	811 <b>R5</b>	1.82	
	811 R7	2.10	
	811 R8	2.11	
	<b>811/1011 R9</b>	2.47	
	<b>811/1011 R10</b>	2.98	
	<b>811/1011 R12</b>	3.36	
	<b>811/1011 R13</b>	3.67	
	<b>811/1011 R14</b>	3.98	
	911 R4	1.79	
	911 <b>R5</b>	1.79	
	911 R7	2.07	
	911 R8	2.08	
	911 R9	2.43	
	911 <b>R10</b>	2.93	
	911 R12	3.32	
	911 R13	3.63	
	911 R14	3.94	
	1011 R15	4.63	
	<b>1111/1211 R8</b>	1.60	
	<b>1111/1211 R9</b>	1.87	
	<b>1111/1211 R10</b>	2.27	
	<b>1111/1211 R12</b>	2.58	
	<b>1111/1211 R13</b>	2.66	
	<b>1111/1211 R14</b>	2.88	
	<b>1111/1211 R15</b>	3.35	

— continued —

**Table 3**  
**Software program storage requirements (continued)**

<b>Program</b> <b>(1K = 1024 words)</b>	<b>Version</b>	<b>Storage in Ks</b>	<b>Comments</b>
ODAS	711, 811/1011, 911	1.12	
	711, 811/1011, 911 R9	1.22	
	711, 811/1011, 911 R10-12	1.21	
	711, 811/1011 R13	1.22	
	811/1011 R14	1.22	
	911 R13-14	1.20	
	1011 R15	0.72	
	1111/1211 R8	0.88	
	1111/1211 R9	0.96	
	1111/1211 R10-12	0.94	
	1111/1211 R13-15	0.88	
	— continued —		

Table 3  
Software program storage requirements (continued)

Program (1K = 1024 words)	Version	Storage in Ks	Comments
DI	711 R4-5	0.58	
	711 R7	0.61'	
	711 R8-9	0.63	
	711 R10	0.65	
	711 R12	0.68	
	711 R13	0.67	
	811 R4-5	0.58	
	811 R7	0.61	
	811 R8	0.63	
	811/1011 R9	0.63	
	811/1011 R10-12	0.65	
	811/1011 R13	0.67	
	811/1011 R14	0.70	..
	911 R4-5	0.57	
	911 R7	0.59	
	911 R8-9	0.62	
	911 R10	0.62	
	911 R12-13	0.67	
	911 R14	0.69	---
	1011 R15	0.74	
1111/1211 R8-9	0.46		
1111/1211 R10	0.47		
1111/1211 R12	0.50		
1111/1211 R13	0.49		
1111/1211 R14	0.50		
1111/1211 R15	0.54		

----- continued -----

**Table 3**  
**Software program storage requirements (continued)**

<b>Program</b> (1K = 1024 words)	<b>Version</b>	<b>Storage in Ks</b>	<b>Comments</b>
DISA	711 R4-5	0.28	
	711 R7	0.29	
	711 R8-10	0.30	
	711 R12-13	0.32	
	811 R4-5	0.28	
	811 R7	0.29	
	811 R8	0.30	
	811/1011 R9-10	0.30	
	811/1011 R12-13	0.32	
	811/1011 R14	0.34	
	911 R4	0.27	
	911 R5	0.28	
	911 R7-8	0.29	
	911 R9-10	0.30	
	911 R12	0.34	
	911 R13	0.32	
	911 R14	0.34	
	1011 R15	0.35	
	1111/1211 R8-10	0.22	
	111 1/1211 R12	0.26	
	1111/1211 R13	0.23	
	1111/1211 R14-15	0.25	

— continued —

**Table 3**  
**Software program storage requirements (continued)**

Program (1K = 1024 words)	Version	Storage in Ks	Comments
CHG	711 R4-5	0.24	
	711 R7	0.29	
	711 R8	0.34	
	711 R9-12	0.35	
	711 R13	0.37	
	811 R4-5	0.24	
	811 R7	0.29	
	811 R8	0.34	
	811/1011 R9-12	0.35	
	811/1011 R13	0.37	
	811/1011 R14-15	0.38	
	911 R4-5	0.24	
	911 R7	0.28	
	911 R8	0.33	
	911 R9-12	0.34	
	911 R13	0.37	
	911 R14	0.38	
	1111/1211 R8-10	0.25	
	1111/1211 R12	0.26	
	1111/1211 R13	0.27	
1111/1211 R14-15	0.28		

— continued —

Table 3  
Software program storage requirements (continued)

Program (1K = 1024 words)	Version	Storage in Ks	Comments
CAB	711 R4	1.11	
	711 R5-9	1.12	
	711 R10-12	1.14	
	711 R13	1.24	
	811 R4	1.11	
	811 R5-8	1.12	
	811/1011 R9	1.12	
	8 1 1/101 1 R10-12	1.14	
	811/1011R13	1.24	
	811/1011R14	1.26	
	911 R4	1.10	
	911 R5-7	1.11	
	911 R8-9	1.12	
	911 R10-12	1.13	
	911 R13	1.23	
	911 R14	1.25	
	1011R15	1.28	
	111 1/1211 R8-9	0.84	
	1111/1211 R10-12	0.85	
	1111/1211R13	0.88	
1111/1211R14	0.90		
1111/1211R15	0.91		
3AUT	711 R4-12	0.30	
	711 R13	0.31	
	811 R4-8	0.30	
	811 R9	0.30	
	81 1/1011 R10-12	0.30	
	811/1011 R13-15	0.31	
	911 R4-12	0.29	
	911 R13	0.30	
	911 R14	0.31	
	1111/1211 R8-12	0.22	
1111/1211 R13-15	0.21		

— continued —

Table 3  
Software program storage requirements (continued)

<b>Program</b> <b>(1K = 1024 words)</b>	<b>Version</b>	<b>Storage in Ks</b>	<b>Comments</b>
CASM	711 R4-5	0.14	
	711 R7-10	0.15	
	711 R12	0.16	
	711 R13	0.19	
	811 R4-5	0.14	
	811 R7-8	0.15	
	811/1011 R9-10	0.15	
	811/1011 R12	0.17	
	811/1011 R13	0.19	
	811/1011 R14	0.22	
	911 R4-5	0.13	
	911 R7-10	0.15	
	911 R12	0.17	
	911 R13	0.19	
	911 R14	0.22	
	1011 R15	0.23	
	1111/1211 R8-10	0.11	
	1111/1211 R12	0.13	
	1111/1211 R13	0.14	---
	1111/1211 R14	0.16	
1111/1211 R15	0.17		

--- continued ---



**Table 3**  
**Software program storage requirements (continued)**

<b>Program</b> <b>(1K = 1024 words)</b>	<b>Version</b>	<b>Storage in Ks</b>	<b>Comments</b>
<b>CASR</b>	<b>711 R4</b>	<b>6.05</b>	
	<b>711 R5</b>	<b>6.08</b>	
	<b>711 R7</b>	<b>6.53</b>	
	<b>711 R8</b>	<b>6.54</b>	
	<b>711 R9</b>	<b>6.60</b>	
	<b>711 R10</b>	<b>6.64</b>	
	<b>711 R12</b>	<b>6.81</b>	
	<b>711 R13</b>	<b>6.92</b>	
	<b>811 R4</b>	<b>6.06</b>	
	<b>811 R5</b>	<b>6.12</b>	
	<b>811 R7</b>	<b>6.57</b>	
	<b>811 R8</b>	<b>6.59</b>	
	<b>811/1011 R9</b>	<b>6.65</b>	
	<b>811/1011 R10</b>	<b>6.69</b>	
	<b>81 1/101 1 R12</b>	<b>6.86</b>	
	<b>811/1011 R13</b>	<b>6.97</b>	
	<b>81 1/101 1 R14</b>	<b>7.49</b>	
	<b>911 R4</b>	<b>5.97</b>	
	<b>911 R5</b>	<b>6.02</b>	
	<b>911 R7</b>	<b>6.52</b>	
	<b>911 R8</b>	<b>6.53</b>	
	<b>911 R9</b>	<b>6.60</b>	
	<b>911 R10</b>	<b>6.64</b>	
	<b>911 R12</b>	<b>6.80</b>	
	<b>911 R13</b>	<b>6.92</b>	
	<b>911 R14</b>	<b>7.44</b>	
	<b>1011 R15</b>	<b>7.85</b>	
	<b>1111/1211 R8</b>	<b>5.14</b>	
	<b>1111/1211 R9</b>	<b>5.19</b>	
	<b>1111/1211 R10</b>	<b>5.22</b>	
	<b>1111/1211 R12</b>	<b>5.34</b>	
	<b>1111/1211 R13</b>	<b>4.95</b>	
	<b>111 1/121 1 R14</b>	<b>5.33</b>	
	<b>1111/1211 R15</b>	<b>5.56</b>	

— continued —

**Table 3**  
**Software program storage requirements (continued)**

<b>Program (1K = 1024 words)</b>	<b>Version</b>	<b>Storage in Ks</b>	<b>Comments</b>
BQUE	711 R4	2.05	
	711 R5	2.15	
	711 R7	2.27	
	711 R8	2.29	
	711 R9	2.33	
	711 R10	2.42	
	711 R11	2.46	
	711 R12	2.47	
	711 R13	2.55	
	811 R4	2.06	
	811 R5	2.16	
	811 R7	2.27	
	811 R8	2.29	
	811/1011 R9	2.33	
	811/1011 R10	2.43	
	811/1011 R12	2.56	
	811/1011 R13	2.47	
	811/1011 R14	2.52	
	911 R4	2.03	
	911 R5	2.12	
	911 R7	2.24	
	911 R8	2.25	
	911 R9	2.29	
	911 R10	2.39	
	911 R12	2.53	
	911 R13	2.43	
	911 R14	2.59	
	1011 R15	2.70	
	1111/1211 R8	1.76	
	1111/1211 R9	1.79	
	1111/1211 R10	1.86	
	1111/1211 R12	1.89	
	1111/1211 R13	1.83	
	1111/1211 R14	1.87	
	1111/1211 R15	1.93	

— continued —

Table 3  
Software program storage requirements (continued)

Program (1K = 1024 words)	Version	Storage in Ks	Comments
NTRF	711 R4-13	0.54	
	811 R4-8	0.54	
	811/1011 R9-15	0.54	
	911 R4-8	0.52	
	911 R9-14	0.53	
	1111/1211 R8	0.44	
	1111/1211 R9-10	0.45	
	1111/1211 R12	0.45	
	1111/1211 R13-15	0.38	
CMAC	711 R4-5	0.82	
	711 R7-12	0.83	
	711 R13	1.00	
	811 R4-5	0.82	
	811 R7-8	0.83	
	811/1011 R9-12	0.83	
	811/1011 R13-15	1.00	
	911 R4-5	0.81	
	911 R7-12	0.83	
	911 R13	0.97	
	911 R14-15	1.00	
	1111/1211 R8-15	0.70	
MCDR	711 R4-12	1.20	
	711 R13	1.31	
	811 R4	1.20	
	811 R5-8		Note 5
	811/1011 R9-13		Note 5
	811/1011 R14-15	1.31	
	911 R4	1.19	
	911 R5-13		Note 5
	911 R14-15	1.29	
	1111/1211 R8-13		Note 5
	1111/1211 R14-15	0.91	

--- continued ---

Table 3  
Software program storage requirements (continued)

Program (1K = 1024 words)	Version	Storage in Ks	Comments
NCOS	711, 811, 911, 1011	0.10	
	711, 811, 911, 1011 R13	0.08*	
	811, 911, 1011 R14-15	0.08	
	1011 R15	0.08	
	1111/1211 R8-12	0.08	
	1111/1211 R13-15	0.06	
— continued —			

**Table 3**  
**Software program storage requirements (continued)**

<b>Program</b> <b>(1K = 1024 words)</b>	<b>Version</b>	<b>Storage in Ks</b>	<b>Comments</b>
<b>CPRK</b>	711 R4-5	3.41	
	711 R7	3.51	
	711 R8	3.53	
	711 <b>R9</b>	3.54	
	711 <b>R10</b>	3.58	
	711 R12	3.76	
	711 R13	3.98	
	811 R4-5	3.41	
	811 R7	3.51	
	811 R8	3.53	
	<b>811/1011 R9</b>	3.53	
	<b>811/1011 R10</b>	3.58	
	<b>811/1011 R12</b>	3.76	
	<b>811/1011 R13</b>	3.98	
	<b>811/1011 R14</b>	4.12	
	911 R4	3.35	
	911 R5	3.36	
	911 R7	3.45	
	911 <b>R8-9</b>	3.47	
	911 <b>R10</b>	3.52	
	911 R12	3.70	
	911 R13	3.95	
	911 R14	4.09	
	1011 R15	4.23	
	<b>1111/1211 R8-9</b>	2.60	
	<b>1111/1211 R10</b>	2.62	
	<b>1111/1211 R12</b>	2.76	
	<b>1111/1211 R13</b>	2.80	
	<b>1111/1211 R14</b>	<b>2.90</b>	
	<b>1111/1211 R15</b>	2.97	

-- continued --

**Table 3**  
**Software program storage requirements (continued)**

Program (1K = 1024 words)	Version	Storage in Ks	Comments
s s c	711, 811, 911, 1011	0.10	
	811, 911, 1011 R14-15	0.10'	
	1111/1211 R8-15	0.08	
IMS (UST, UMG)	711 R4	7.47	
	711 R5	7.49	
	711 R7	7.59	
	711 R8	7.63	
	711 R9	7.70	
	711 R10	2.80	
	711 R12	2.83	
	711 R13	3.00	
	811 R4	7.47	
	811 R5	7.49	
	811 R7	7.59	
	811 R8	7.63	
	811/1011 R9	7.70	
	811/1011 R10	2.80	
	811/1011 R12	2.83	
	811/1011 R13	3.00	
	811/1011 R14-15	3.02	
	911 R4	7.36	
	911 R5	7.38	
	911 R7	7.47	
	911 R8	7.51	
	911 R9	7.58	
	911 R10	2.75	
	911 R12	2.79	
	911 R13	2.97	
	911 R14	<b>2.98</b>	
	1111/1211 R8	5.97	
1111/1211 R9	6.03		
1111/1211 R10	2.12		
1111/1211 R12	2.14		
1111/1211 R13	2.16		
1111/1211 R14-15	2.17		

— continued —

Table 3  
Software program storage requirements (continued)

Program (1K = 1024 words)	Version	Storage in Ks	Comments
ROA	711	0.36	
	711 R10	0.36	
	711 R12	0.38	
	711 R13	0.40	
	811/1011	0.38	
	811/1011 R10	0.38	
	811/1011 R12	0.38	
	811/1011 R13	0.40	
	811/1011 R14	0.42	
	911 R4-7	0.36	
	911 R8	0.10	
	911 R10	0.27	
	911 R12	0.10	
	911 R13-14	0.11	
	1011 R15	0.43	
	1111/1211 R8-9	0.08	
	1111/1211 R10-14	0.08	
	1111/1211 R15	0.31	

— continued —

Table 3  
Software program storage requirements (continued)

<b>Program</b> (1K = 1024 words)	<b>Version</b>	<b>Storage in K<sub>S</sub></b>	<b>Comments</b>
INSIG	711 R4	2.03	
	711 R5-7	2.30	
	711 R8-10	2.32	
	711 R12-13	2.63	
	811 R4	2.03	
	811 R5-7	2.30	
	811 R8	2.32	
	811/1011 R9-10	2.32	
	811/1011 R12-13	2.63	
	811/1011 R14	2.68	
	911 R4	1.99	
	911 R5-7	2.26	
	911 R8-10	2.27	
	911 R12	2.65	
	911 R13	2.59	
	911 R14	2.64	
	1011 R15	2.69	
	1111/1211 R8-10	1.83	
	1111/1211 R12	2.09	
	1111/1211 R13	1.97	
1111/1211 R14-15	2.01		

— continued —



**Table 3**  
**Software program storage requirements (continued)**

Program (1K = 1024 words)	Version	Storage in Ks	Comments
MCBQ	711 R4	2.53	
	711 R5	2.56	
	711 R7	2.66	
	711 R8	2.67	
	711 R10-12	2.68	
	711 R13	2.76	
	811 R4	2.54	
	811 R5	2.57	
	811 R7	2.68	
	811 R8	2.67	
	811/1011 R9	2.69	
	811/1011 R10-12	2.70	
	811/1011 R13	2.78	
	811/1011 R14	2.81	
	911 R4	2.50	
	911 R5	2.52	
	911 R7-8	2.63	
	911 R9	2.64	
	911 R10-12	2.65	
	911 R13	2.74	
	911 R14	2.78	
	1011 R15	2.86	
	1111/1211 R8	2.07	
	1111/1211 R9	2.08	
	1111/1211 R10-12	2.09	
	1111/1211 R13	1.95	
	1111/1211 R14	1.98	
	111/1211 R15	2.01	
	NSC	711, 811, 911, 1011, 1111, 1211	0

— continued —

Table 3  
Software program storage requirements (continued)

Program (1K = 1024 words)	Version	Storage in Ks	Comments
BACD	711 R4	8.98	
	711 R5	9.01'	
	711 R7	10.68	
	711 R8	10.91	
	711 R9	11.64	
	711 R10	12.79	
	711 R12	15.02	
	711 R13	15.66	
	811 R4	8.99	
	811 R5	9.01	
	811 R7	10.86	
	811 R8	10.92	
	811/1011 R9	11.67	
	811/1011 R10	12.83	
	811/1011 R12	15.05	
	811/1011 R13	15.69	
	811 R14	16.13	
	911 R4	8.85	
	911 R5	8.87	
	911 R7	10.69	
	911 R8	10.75	
	911 R9	11.84	
	911 R10	12.97	
	911 R12	15.17	
	911 Ri3	15.90	
	911 R14	16.35	
	1011 R15	17.63	
	1111/1211 R8	8.50	
	1111/1211 R9	9.35	
	1111/1211 R10	10.24	
	1111/1211 R12	11.97	
	1111/1211 R13	11.36	
1111/1211 R14	11.68		
1111/1211 R15	12.78		

-- continued --

**Table 3**  
**Software program storage requirements (continued)**

<b>Program</b> <b>(1K = 1024 words)</b>	<b>Version</b>	<b>Storage in Ks</b>	<b>Comments</b>
ACDB	711	0.05	
	711 R12	0.09	
	711 R13	0.12	
	811 R4-7	0.05	
	811 R8	0.04	
	811/1011 R9-10	0.05	
	811/1011 R12	<b>0.09</b>	
	811/1011 R13-14	0.12	
	911	0.05	
	911 R12	0.09	
	911 R13-14	0.12	
	1011 R15	0.13	
	1111/1211 R8-10	0.04	
	1111/1211 R12	0.09	
	1111/1211 R13-14	0.08	
	1111/1211 R15	0.09	

**— continued —**

Table 3  
Software program storage requirements (continued)

Program (1K = 1024 words)	Version	Storage in Ks	Comments
ACDC	711 R4	13.54	
	711 R5	13.49	
	711 R7	14.16	
	711 R8	14.19	
	711 R9	14.75	
	711 R10	15.77	
	711 R12	16.97	
	711 R13	17.99	
	811 R4	13.54	
	811 R5	13.49	
	811 R7	14.16	
	811 R8	14.19	
	811/1011 R9	14.75	
	811/1011 R10	15.77	
	811/1011 R12	16.97	
	811/1011 R13	17.99	
	811/1011 R14	17.98	
	911 R4	13.39	
	911 R5	13.34	
	911 R7	14.01	
	911 R8	14.04	
	911 R9	14.60	
	911 R10	15.61	
	911 R12	16.62	
	911 R13-14	17.83	
	1011 R15	20.87	
	1111/1211 R8	11.25	
	1111/1211 R9	11.67	
	1111/1211 R10	12.46	
	1111/1211 R12	13.26	
	1111/1211 R13-14	12.77	
	1111/1211 R15	14.80	
	LMAN	711, 811, 911, 1011, 1111, 1211	0

— continued —

**Table 3**  
**Software program storage requirements (continued)**

<b>Program (1K = 1024 words)</b>	<b>Version</b>	<b>Storage in Ks</b>	<b>Comments</b>
MUS	711 R4-5	1.03	
	711 R7-9	1.04	
	711 R10	1.05	
	711 R12	1.28	
	711 R13	1.29	
	811 R4	1.03	
	811 R5-7	1.04	
	811/1011 R8-10	1.05	
	811/1011 R12	1.06	
	811/1011 R13-14	1.29	
	911 R4-5	1.28	
	911 R7-9	1.01	
	911 R10	1.02	
	911 R12	1.03	
	911 R13	1.26	
	911 R14	1.27	
	1011 R15	1.39	
	1111/1211 R8-9	1.25	
	1111/1211 R10	0.81	
	1111/1211 R12	0.99	
1111/1211 R13-14	0.91		
1111/1211 R15	0.97		
ACDA	711, 811, 911, 1011, 1111, 1211	0	All Releases

— continued —

Table 3  
Software program storage requirements (continued)

Program (1K = 1024 words)	Version	Storage in Ks	Comments
MWC	711 R4-5	1.19	
	711 R7-8	1.24	
	711 R9	1.26	
	711 R10	1.29	
	711 R12	1.38	
	711 R13	1.42	
	811 R4-5	1.19	
	811 R7-8	1.24	
	811/1011 R9	1.26	
	811/1011 R10	1.29	
	811/1011 R12	1.38	
	811/1011 R13	1.42	
	811/1011 R14	1.43	
	911 R4-5	1.16	
	911 R7	1.20	
	911 R8	1.21	
	911 R9	1.23	
	911 R10	1.26	
	911 R12	1.35	
	911 R13	1.40	
	911 R14	1.41	
	1011 R15	2.80	
	1111/1211 R8	0.92	
	1111/1211 R9	0.93	
	1111/1211 R10	0.96	
	1111/1211 R12	1.02	
	1111/1211 R13-14	1.01	
	1111/1211 R15	2.03	

— continued —

**Table 3**  
**Software program storage requirements (continued)**

<b>Program (1K = 1024 words)</b>	<b>Version</b>	<b>Storage in Ks</b>	<b>Comments</b>
AAB	711 R4-5	0.07	
	711 R7-13	0.11	
	811 R4-5	0.07	
	811/1011 R7-14	0.11	
	911 R4-5	0.07	
	911 R7-14	0.11	
	1011 R15	0.12	
	1111/1211 R8	0.08	
	1111/1211 R9-13	0.09	
	1111/1211 R14-15	0.08	
— continued —			

Table 3  
Software program storage requirements (continued)

Program (1K = 1024 words)	Version	Storage in Ks	Comments
GRP	711 R4	2.19	
	711 R5	2.17	
	711 R7	2.20	
	711 R8-9	2.22	
	711 R10	2.26	
	711 R11	2.25	
	711 R12	2.29	
	711 R13	2.13	
	811 R4	2.18	
	811 R5	2.17	
	811 R7	2.19	
	811/1011 R8-9	2.21	
	811/1011 R10	2.25	
	811/1011 R12	2.28	
	811/1011 R13	2.13	
	811/1011 R14	2.32	
	911 R4	2.15	
	911 R5	2.13	
	911 R7	2.16	
	911 R8-9	2.18	
	911 R10	2.22	
	911 R12	2.24	
	911 R13	1.65	
	911 R14	2.30	
	1011 R15	2.35	
	1111/1211 R8-9	2.11	
	1111/1211 R10	1.68	
	1111/1211 R12	1.70	
	1111/1211 R13	1.49	
	1111/1211 R14	1.63	
	1111/1211 R15	1.65	

— continued —



**Table 3**  
**Software program storage requirements (continued)**

Program (1K = 1024 words)	Version	Storage in Ks	Comments
INFCR	7 11 (before R9)	0.29	
	711 R9	0.38	
	711 R10	0.44	
	711 R12	0.46	
	711 R13	0.50	
	8 11 (before R9)	0.29	
	811/1011 R9	0.38	
	811/1011 R10	0.44	
	811/1011 R12	0.46	
	811/1011 R13-15	0.50	
	9 11 (before R9)	0.29	
	911 R9	0.38	
	911 R10	0.43	
	911 R12	0.45	
	911 R13-14	0.49	
	1111/1211 R8	0.23	
	1111/1211 R9	0.30	
	1111/1211 R10	0.33	
	1111/1211 R12-15	0.35	
	LNK	711, 811, 911	0.15
711, 811/1011 R13		3.46	
811/1011 R14		3.46	
911 R13-14		3.43	
1011 R15		4.37	
1011, 1111/1211		0.12	
111/1211 R13-14		2.45	
111/1211 R15		3.08	
— continued —			

**Table 3**  
**Software program storage requirements (continued)**

Program (1K = 1024 words)	Version	Storage in Ks	Comments
ACDD	711 R4-5	2.22	
	711 R7-9	2.23	
	711 R10	2.50	
	711 R12	2.83	
	711 R13	1.50	
	811 R4-5	2.22	
	811/1011 R7-9	2.23	
	811/1011 R10	2.53	
	811/1011 R12	2.83	
	811/1011 R13-15	1.50	
	911 R4-5	2.19	
	911 R7	2.20	
	911 R8-9	2.21	
	911 R10	2.50	
	911 R12	2.80	
	911 R13-14	1.50	
	1111/1211 R8-9	1.85	
	1111/1211 R10	2.07	
1111/1211 R12	2.33		
1111/1211 R13-15	1.03		
FCA	711, 811, 911, 1011, 1111, 1211	0	All Releases

— continued —

**Table 3**  
**Software program storage requirements (continued)**

<b>Program</b> <b>(1K = 1024 words)</b>	<b>Version</b>	<b>Storage in Ks</b>	<b>Comments</b>
SR	711 R4-5	4.13	
	711 R7	4.36	
	711 R8	4.51	
	711 R9	4.87	
	711 R10	5.48	
	711 R12	5.97	
	711 R13	6.19	
	811 R4-5	4.13	
	811 R7	4.36	
	811 R8	4.51	
	811/1011 R9	4.87	
	811/1011 R10	5.48	
	811/1011 R12	5.97	
	811/1011 R13	6.19	
	811/1011 R14	6.50	
	911 R4-5	4.06	
	911 R7	4.29	
	911 R8	4.44	
	911 R9	4.80	
	911 R10	5.41	
	911 R12	5.89	
	911 R13	6.13	
	911 R14	6.44	
	1011 R15	6.56	
	1111/1211 R8	3.52	
	1111/1211 R9	3.73	
	1111/1211 R10	4.20	
	1111/1211 R12	4.56	
	1111/1211 R13	4.35	
	1111/1211 R14	4.57	
	1111/1211 R15	4.61	

— continued —

**Table 3**  
**Software program storage requirements (continued)**

<b>Program (1K = 1024 words)</b>	<b>Version</b>	<b>Storage in Ks</b>	<b>Comments</b>
AA	711 R4-5	<b>0.58</b>	
	711 R7	0.59	
	711 R8-12	0.65	
	711 R13	0.64	
	811 R4-5	0.58	
	811 R7	0.59	
	811/1011 R8-14	0.65	
	911 R4-5	0.57	
	911 R7	0.58	
	911 R8-14	0.64	
	1011 R15	1.00	
	1111/1211 R8-14	<b>0.47</b>	
	1111/1211 R15	<b>0.73</b>	
HIST	711, 811, 911, 1011	0.04	
	811, 911, 1011 R14-15	0.04	
	111 1/1211 R8-15	<b>0.03</b>	

— continued —

**Table 3**  
**Software program storage requirements (continued)**

<b>Program</b> <b>(1K = 1024 words)</b>	<b>Version</b>	<b>Storage in Ks</b>	<b>Comments</b>
AOP	711 R4-5	0.42	
	711 R7	0.54	
	711 R8	0.62	
	711 R9-12	0.63	
	711 R13	0.65	
	811 R4-5	0.42	
	811 R7	0.54	
	811 R8	0.62	
	811/1011 R9-12	0.63	
	811/1011 R13	0.65	
	811/1011 R14	<b>0.64</b>	
	911 R4-5	0.42	
	911 R7	0.52	
	911 R8	0.60	
	911 R10-12	0.61	
	911 R13-14	0.63	
	1011 R15	0.80	
	1111/1211 R8-9	0.44	
	1111/1211 R10-14	0.45	
	1111/1211 R15	0.56	
--- continued ---			

**Table 3**  
**Software program storage requirements (continued)**

Program (1K = 1024 words)	Version	Storage in Ks	Comments
BARS	711, 811, 911, 1011, 1111/1211	0	All Releases
NARS	711, 811, 911, 1011, 1111/1211	0	All Releases
CDP	711, 811, 911, 1011	0.07	
	711, 811/1011 R13	0.08	
	811/1011 R14-15	0.08	
	911 R13	0.09	
	911 R14	0.07	
	1111/1211 R14-15	0.05	
PQUE	711, 811, 911, 1011, 1111/1211	0	All Releases
FCBQ	711, 811, 911, 1011	0.02	All Releases
	1111/1211	0.02	
	1111/1211 R13-15	0.01	
OHQ	711 R4, 5, 7	0.11	
	711 R8-13	0.12	
	811 R4-7	0.11	
	811 R8-9	0.12	
	811/1011 R10-15	0.12	
	911	0.11	
	911 R13-14	0.12	
	1111/1211 R8-12	0.09	
	1111/1211 R13-15	0.08	

— continued —

56 Memory calculations

Table 3  
Software program storage requirements (continued)

<b>Program</b> <b>(1K = 1024 words)</b>	<b>Version</b>	<b>Storage in Ks</b>	<b>Comments</b>
NAUT	711 R4-5	0.49	
	711 R7-12	0.50	
	711 R13	0.51	
	811 R4-5	0.49	
	811 R7	0.50	
	811/1011 R8-12	0.50	
	811/1011 R13	0.51	
	811/1011 R14	0.55	
	911 R4-5	0.48	
	911 R7-12	0.49	
	911 R13	0.50	
	911 R14	0.54	
	1011 R15	0.57	
	1111/1211 R8-10	0.38	
	1111/1211 R12	0.37	
	1111/1211 R13	0.36	
	1111/1211 R14	0.40	
1111/1211 R15	0.41		

— continued —

Table 3  
Software program storage requirements (continued)

Program (1K = 1024 words)	Version	Storage in Ks	Comments
SNR	711 R4-5	0.76	
	711 R7	0.78	
	711 R8-12	0.84	
	711 R13	0.85	
	811 R4-5	0.76	
	811 R7	0.78	
	811/1011 R8-12	0.84	
	811/1011 R13	0.85	
	811/1011 R14	0.93	
	911 R4-5	0.75	
	911 R7	0.77	
	911 R8-12	0.83	
	911 R13	0.85	
	911 R14	0.92	
	1011 R15	0.96	
	1111/1211 R8-12	0.59	
	1111/1211 R13	0.60	
	1111/1211 R14	0.65	
	1111/1211 R15	0.68	---

— continued —



Table 3  
Software program storage requirements (continued)

Program (1K = 1024 words)	Version	Storage in Ks	Comments
TDET	711 R4	0.36	
	711 R5-12	0.39	
	711 R13	0.42	
	811 R4	0.36	
	811 R5-7	0.38	
	811/1011 R8-12	0.38	
	811/1011 R13-14	0.42	
	911 R4	0.35	
	911 R5-12	0.38	
	911 R13-14	0.41	
	1011 R15	0.45	
	1111/1211 R8-14	0.30	
	1111/1211 R15	0.32	
SCC	711, 811, 911, 1011, 1111, 1211	0	All Releases
NXFR	711 R4-5	0.51	
	711 R7-9	0.62	
	711 R10-12	0.65	
	711 R13	0.71	
	811 R4-5	0.51	
	811 R7	0.62	
	811/1011 R8-9	0.62	
	811/1011 R10-12	0.65	
	811/1011 R13-14	0.71	
	911 R4-5	0.51	
	911 R7-9	0.61	
	911 R10-12	0.64	
	911 R13	0.70	
	911 R14	0.71	
	1011 R15	0.72	
1111/1211 R8-9	0.51		
1111/1211 R10-12	0.53		
1111/1211 R13-15	0.50		

— continued —

Table 3  
Software program storage requirements (continued)

Program (1K = 1024 words)	Version	Storage in Ks	Comments
ATVN	711 R4	4.99	
	711 R5-7	5.00	
	711 R8	5.02	
	711 R9	5.03	
	711 R10	5.12	
	711 R12	5.18	
	711 R13	5.25	
	811 R4	4.97	
	811 R5-7	4.98	
	811 R8	5.00	
	811/1011 R9	5.01	
	811/1011 R10	5.10	
	811/1011 R12	5.17	
	811/1011 R13	5.24	
	811/1011 R14	5.29	
	911 R4	4.92	
	911 R5-7	4.93	
	911 R8-9	4.95	
	911 R10	5.04	
	911 R12	5.11	
	911 R13	5.20	
	911 R14	5.25	
	1011 R15	5.52	
	1111/1211 R8	3.92	
	1111/1211 R9	3.93	
	1111/1211 R10	4.00	
	1111/1211 R12	4.05	
	1111/1211 R13	3.80	
	1111/1211 R14	3.84	
	1111/1211 R15	3.99	
ACDR	711, 811, 911, 1011, 1111/1211	0	All Releases

— continued —

**Table 3**  
**Software program storage requirements (continued)**

Program (1K = 1024 words)	Version	Storage in Ks	Comments
HOT	711 (before R10)	0	
	711 R10-12	0.24	
	711 R13	0.26	
	811/1011 (before R10)	0	
	811/1011 R10-12	0.24	
	811/1011 R13	0.25	
	811/1011 R14-15	0.26	
	911 (before R10)	0	
	911 R10-12	0.24	
	911 R13	0.25	
	911 R14	0.26	
	1111/1211 (before R10)	0	
	1111/1211 R10	0.24	
	1111/1211 R12-13	0.18	
	1111/1211 R14-15	0.19	
DHLD	711, 811/1011	0.58	
	711, 811/1011 R12	0.59	
	711, 811/1011 R13-15	0.61	
	911	0.57	
	911 R12	0.59	
	911 R13-14	0.60	
	1111/1211 R8-10	0.46	
	1111/1211 R12	0.47	
	1111/1211 R13-15	0.44	
LSEL	711, 811/1011	0.17	All Releases
	911 R4-5	0.16	
	911 R7-14	0.17	
	1111/1211 R8-15	0.12	

— continued —

Table 3  
Software program storage requirements (continued)

Program (1K = 1024 words)	Version	Storage in Ks	Comments
SS5	711, 811, 911, 1011, 1111/1211	0.01	All Releases
DRNG	711 R4-5, 7	0.41	
	711 R8	0.49	
	711 R9	0.48	
	711 R10	0.68	
	711 R12	0.70	
	711 R13	0.58	
	811 R4-5, 7	0.41	
	811 R8	0.49	
	811/1011 R9	0.48	
	811/1011 R10-12	0.70	
	811/1011 R13	0.60	
	811/1011 R14-15	0.58	
	911 R4-5, 7	0.40	
	911 R8-9	0.48	
	911 R10-12	0.69	
	911 R13-14	0.57	
	1111/1211 R8	0.39	
	1111/1211 R9	0.38	
	1111/1211 R10-12	0.55	
	1111/1211 R13-15	0.42	
--- continued ---			

**Table 3**  
**Software program storage requirements (continued)**

<b>Program (1K = 1024 words)</b>	<b>Version</b>	<b>Storage in Ks</b>	<b>Comments</b>
<b>PBXI</b>	<b>711 R5</b>	<b>2.84</b>	
	<b>711 R7</b>	<b>4.28</b>	
	<b>711 R8</b>	<b>4.70</b>	
	<b>711 R9-10</b>	<b>4.82</b>	
	<b>711 R12</b>	<b>6.26</b>	
	<b>711 R13</b>	<b>6.24</b>	
	<b>811 R5</b>	<b>3.27</b>	
	<b>811 R7</b>	<b>4.72</b>	
	<b>811 R8</b>	<b>4.76</b>	
	<b>811/1011 R9-10</b>	<b>4.89</b>	
	<b>811/1011 R12</b>	<b>6.33</b>	
	<b>811/1011 R13</b>	<b>6.31</b>	
	<b>811/1011 R14</b>	<b>7.14</b>	
	<b>911 R5</b>	<b>3.23</b>	
	<b>911 R7</b>	<b>4.66</b>	
	<b>911 R8</b>	<b>4.70</b>	
	<b>911 R9</b>	<b>4.82</b>	
	<b>911 R10</b>	<b>4.83</b>	
	<b>911 R12</b>	<b>6.25</b>	
	<b>911 R13</b>	<b>6.24</b>	
	<b>911 R14</b>	<b>7.04</b>	
	<b>1011 R15</b>	<b>7.26</b>	
	<b>1111/1211 R8</b>	<b>3.71</b>	
	<b>1111/1211 R9</b>	<b>3.83</b>	
	<b>1111/1211 R10</b>	<b>3.84</b>	
	<b>1111/1211 R12</b>	<b>4.94</b>	
	<b>1111/1211 R13</b>	<b>4.57</b>	
	<b>1111/1211 R14</b>	<b>5.18</b>	
	<b>1111/1211 R15</b>	<b>5.26</b>	

— continued —

**Table 3**  
**Software program storage requirements (continued)**

Program (1K = 1024 words)	Version	Storage in Ks	Comments
DLDN	711 R5-13	0.09.	
	811 R5-7	0.09	
	811/1011 R8-15	0.09	
	911 R5-15	0.09	
	1111/1211 R8-13	0.06	
	1111/1211 R15	0.07	
AMP	711 R5	1.37	
	711 R7-8	1.44	
	711 R9	1.46	
	711 R10-12	1.47	
	711 R13	1.57	
	811 R5	1.37	
	811 R7-8	1.44	
	811/1011 R9	1.46	
	811/1011 R10-12	1.47	
	811/1011 R13	1.57	
	811/1011 R14	1.61	
	911 R5	1.36	
	911 R7	1.44	
	911 R8	1.43	
	911 R9	1.45	
	911 R10-12	1.46	
	911 R13	1.57	
	911 R14	1.61	
	1011 R15	1.62	
	1111/1211 R8	1.09	
	1111/1211 R9	1.11	
1111/1211 R10-13	1.12		
1111/1211 R14	1.15		
1111/1211 R15	1.16		

— continued —

**Table 3**  
**Software program storage requirements (continued)**

<b>Program (1K = 1024 words)</b>	<b>Version</b>	<b>Storage in Ks</b>	<b>Comments</b>
CSL	711 R7	13.96	
	711 R8	14.68	
	711 R9	15.10	
	711 R10	15.08	
	711 R12	17.04	
	711 R13	17.65	
	811 R7	13.96	
	811 R8	14.68	
	811 R9	15.10	
	81 1/1011 R10	15.08	
	81 1/101 1 R12	17.04	
	81 1/1011 R13	17.64	
	811/1011 R14	17.65	
	911 R7	13.55	
	911 R8	14.26	
	911 R9	14.69	
	911 R10	14.67	
	911 R12	16.61	
	911 R13-14	17.24	
	1011 R15	17.80	
	1111/1211 R8	11.23	
	1111/1211 R9	11.51	
	1111/1211 R10	11.49	
	1111/1211 R12	12.99	
	111 1/1211 R13-14	12.45	
	1111/1211 R15	12.54	
	OOD	711, 811, 911, 1011, 1111/1211	0
SCI	711 R7-13	0	
	811/1011 R7-15	0	
	911 R7-14	0	
	111 1/1211 R8-15	0	

— continued —

Table 3  
Software program storage requirements (continued)

Program (1K = 1024 words)	Version	Storage in Ks	Comments
CCOS	711 R7-8	0.22	
	711 R9	0.24	
	711 R10-13	0.25	
	811 R7	0.22	
	811 R8	0.21	
	811/1011 R9	0.24	
	811/1011 R10-14	0.25	
	911 R7-8	0.21	
	911 R9	0.23	
	911 R10-12	0.24	
	911 R13-14	0.25	
	1111/1211 R8	0.17	
	1111/1211 R9	0.18	
	1111/1211 R10-14	0.19	
RESDB	811/1011 R14	4.30	
	911 R14	4.47	
	1111/1211 R14	7.46	
CDRQ	711	0	All Releases
	811/1011	0	
	911	0	
	1111/1211	0	
ATM	711	0	All Releases
	811/1011	0	
	911	0	
	1111/1211	0	

— continued —



**Table 3**  
**Software program storage requirements (continued)**

<b>Program</b> (1K = 1024 words)	<b>Version</b>	<b>Storage in Ks</b>	<b>Comments</b>
CSLA	711	0	All Releases
	811/1011	0	
	911	0	
	1111/1211	0	
TENANT	711 R7	0.38	
	711 R8	0.43	
	711 R9-12	0.44	
	711 R13	0.43	
	811 R7	0.38	
	81 1/1011 R8	0.43	
	811/1011 R9	0.44	
	811/1011 R10-12	0.44	
	811/1011 R13	0.43	
	811/1011 R14	0.48	
	911 R7	0.38	
	911 R8	0.43	
	911 R9-12	0.44	
	911 R13	0.43	
	911 1 R14	0.47	
	1011 R15	0.51	
	1111/1211 R8	0.33	
	1111/1211 R9-12	0.34	
	1111/1211 R13	0.32	
	1111/1211 R14	0.35	
1111/1211 R15	0.38		
FTDS	711	0	All Releases
	811/1011	0	
	911	0	
	1111/1211	0	

— continued —

**Table 3**  
**Software program storage requirements (continued)**

Program (1K = 1024 words)	Version	Storage in Ks	Comments
DSET	711 R12	8.70	
	711 R13	8.75	
	811/1011 R12	8.69	
	811/1011 R13	8.74	
	811/1011 R14	9.67	
	911 R12	8.57	
	911 R13	8.66	
	911 R14	9.57	
	1011 R15	12.53	
	1111/1211 R12	6.66	
	1111/1211 R13	6.34	
	1111/1211 R14	6.99	
	1111/1211 R15	9.12	
	TSET	711	0
811/1011		0	
911		0	
1111/1211		0	
LNR	711 R8	0.24	
	711 R9	0.26	
	711 R10-12	0.28	
	711 R13	0.30	
	811 R8	0.24	
	811/1011 R9	0.26	
	811/1011 R10-12	0.28	
	811/1011 R13-15	0.30	
	911 R8	0.24	
	911 R9	0.26	
	911 R10-12	0.28	
	911 R13-14	0.30	
	1111/1211 R8	0.19	
	1111/1211 R9	0.20	
	1111/1211 R10-15	0.22	

— continued —

**Table 3**  
**Software program storage requirements (continued)**

Program (1K = 1024 words)	Version	Storage in Ks	Comments
DLT 2	711 R9-13	0	
	811/1011 R9-14	0	
	911 R9-14	0	
	1111/1211 R9-14	0	
PRETRANS	711 R8	0.33	
	711 R9	0.34	
	711 R10-13	0.35	
	811 R8	0.33	
	811/1011 R9	0.34	
	811/1011 R10-13	0.35	
	811/1011 R14-15	0.37	
	911 R8	0.33	
	911 R10-13	0.34	
	911 R14	0.36	
	1111/1211 R8	0.24	
	1111/1211 R9-13	0.25	
	1111/1211 R14-15	0.26	
SUPV	711 R8	0.77	
	711 R9-12	0.66	
	711 R13	0.68	
	811 R8	0.78	
	811/1011 R9-12	0.67	
	811/1011 R13-14	0.69	
	911 R8	0.77	
	911 R9-12	0.65	
	911 R13	0.67	
	911 R14	0.68	
	1011 R15	0.72	
	1111/1211 R8	0.56	
	1111/1211 R9-14	0.48	
1111/1211 R15	0.50		

— continued —

Table 3  
Software program storage requirements (continued)

Program (1K = 1024 words)	Version	Storage in Ks	Comments
TDS	711 R8-13	0	
	811/1011 R8-14	0	
	911 R8-14	0	
	1111/1211 R8-14	0	
CPND	711 R10-12	0.88	
	711 R13	0.90	
	811/1011 R10-12	0.88	
	811/1011 R13-15	0.90	
	911 R10-12	0.86	
	911 R13-14	0.88	
	1111/1211 R10-12	0.71	
	1111/1211 R13-15	0.64	
SLST	711	0	A Releases
	811/1011	0	
	911	0	
	1111/1211	0	
JPN	711	0	All Releases
	811/1011	0	
	911	0	
	1111/1211	0	
DNIS	711	0	All Releases
	811/1011	0	
	911	0	
	1111/1211	0	

— continued —

**Table 3**  
**Software program storage requirements (continued)**

Program (1K = 1024 words)	Version	Storage in Ks	Comments
3GD	711 R10	11.21	
	711 R12	11.51	
	711 R13	11.32	
	811/1011 R10	11.21	
	811/1011 R12	11.51	
	811/1011 R13	11.32	
	811/1011 R14	11.33	
	911 R10	11.09	
	911 R12	11.35	
	911 R13-14	11.22	
	1011 R15	11.54	
	1111/1211 R10	8.90	
	1111/1211 R12	9.13	
	1111/1211 R13-14	8.26	
	1111/1211 R15	8.40	
RMS	711 R10	1.55	
	711 R12	1.58	
	711 R13	1.60	
	811/1011 R10	1.55	
	811/1011 R12	1.58	
	811/1011 R13-14	1.60	
	911 R10	1.53	
	911 R12	1.55	
	911 R13-14	1.58	
	1011 R15	1.67	
	1111/1111 R10	1.20	
	1111/1111 R12	1.22	
	1111/1211 R13-14	1.18	
	1111/1211 R15	1.25	

— continued —

**Table 3**  
**Software program storage requirements (continued)**

<b>Program</b> <b>UK = 1024 words)</b>	<b>Version</b>	<b>Storage in Ks</b>	<b>Comments</b>
MR	711 R10	0.85	
	711 R12	0.85	
	711 R13	0.89	
	811/1011 R10	<b>0.85</b>	
	811/1011 R12	<b>0.85</b>	
	811/1011 R13-15	0.89	
	911 R10	<b>0.83</b>	
	911 R12	<b>0.84</b>	
	911 R13-14	<b>0.88</b>	
	1111/1111 R10-15	0.64	
AWU	711 R10	4.49	
	711 R12	<b>4.57</b>	
	711 R13	<b>4.62</b>	
	811/1011 R10	<b>4.48</b>	
	811/1011 R12	<b>4.58</b>	
	811/1011 R13	4.61	
	811/1011 R14	<b>4.62</b>	
	911 R10	<b>4.43</b>	
	911 R12	4.51	
	911 R13-14	<b>4.58</b>	
	1011 R15	<b>4.34</b>	
	1111/1211 R10	<b>3.35</b>	
	1111/1211 R12	<b>3.40</b>	
	1111/1211 R13-14	<b>3.27</b>	
	1111/1211 R15	<b>3.06</b>	
?MSI	711 R10-13	<b>0.05</b>	
	811/1011 R10-15	<b>0.05</b>	
	911 R10-14	<b>0.05</b>	
	1111/1211 R10-15	0.04	

— continued —

**Table 3**  
**Software program storage requirements (continued)**

Program (1K = 1024 words)	Version	Storage in Ks	Comments
DPAO	711 R10-13	0.05	
	811/1011 R10-15	0.05	
	911 R10-14	0.05	
	1111/1211 R10-15	0.04	
LC	711 R10-13	0.08	
	811/1011 R10-15	0.08	
	911 R10-14	0.08	
	1111/1211 R10-15	0.06	
SLP	711 R10	1.11	
	711 R12	1.17	
	711 R13	1.23	
	811/1011 R10	1.10	
	811/1011 R12	1.17	
	811/1011 R13	1.22	
	811/1011 R14-15	1.23	
	911 R10	1.09	
	911 R12	1.16	
	911 R13	1.21	
	911 R14	1.22	
	1111/1211 R10	0.87	
	1111/1211 R12	0.92	
1111/1211 R13-15	0.89		
MCT	711 R10-13	0.34	
	811/1011 R10-15	0.34	
	911 R10-14	0.34	
	1111/1211 R10	0.29	
	1111/1211 R12	0.28	
	1111/1211 R13	0.27	
	1111/1211 R14-15	0.24	

— continued —

**Table 3**  
**Software program storage requirements (continued)**

Program (1K = 1024 words)	Version	Storage in Ks	Comments
ICDR	711 R10-13	0	
	811/1011 R10-15	0	
	911 R10-14	0	
	1111/1211 R10-15	0	
APL-AUX	711 R10	4.76	
	711 R12	4.77	
	711 R13	5.06	
	811/1011 R10	4.77	
	81 1/1011 R12	4.77	
	811/1011 R13	5.06	
	811/1011 R14-15	5.07	
	911 R10	4.89	..
	911 R12	4.70	
	911 R13	5.00	
	911 R14	5.01	
	1111/1211 R10-12	3.80	
111 1/1211 R10-13	3.70		
1111/1211 R14-15	3.71		
TVS	711 R12-13	0	
	811/1011 R12-15	0	
	911 R12-14	0	
	1111/1211 R12-15	0	
TOF	711 R12-13	0	
	811/1011 R12-15	0	
	911 R12-14	0	
	1111/1211 R12-15	0	

— continued —



Table 3  
Software program storage requirements (continued)

Program (1K = 1024 words)	Version	Storage in Ks	Comments
NKL	81 1/1011 R12-15	0	
	911 R12-14	0	
	1111/1211 R12-15	0	
ISA ISDN PRA	711 R12-13	0	Note 7 for R13
	811/1011 R12-14	0	
	911 R12-14	0	
	1111/1211 R12-14	0	

— continued —

**Table 3**  
**Software program storage requirements (continued)**

Program (1K = 1024 words)	Version	Storage in Ks	Comments
IDC	711 R12	0.37	
	711 R13	0.39	
	811/1011 R12	0.38	
	811/1011 R13	0.39	
	811/1011 R14-15	0.44	
	911 R12	0.37	
	911 R13	0.38	
	911 R14	0.43	
	1111/1211 R12	0.20	
	1111/1211 R13	0.28	
1111/1211 R14-15	0.31		
AUX ACD-D	711 R13	0	
	811/1011 R13-15	0	
	911 R13-14	0	
	1111/1211 R13-15	0	
DCP	<del>711 R13</del> 811/1011 R13	<del>0.18</del> 0.18	---
	811/1011 R14-15	0.19	
	911 R13-14	0.19	
	1111/1211 R13-15	0.14	
ACD Priority Agent	711 R13	0	
	811/1011 R13-15	0	
	911 R13-14	0	
	1111/1211 R13-15	0	
EMUS	711 R13	0	
	811/1011 R13-15	0	
	911 R13-14	0	
	1111/1211 R13-15	0	

— continued —

**Table 3**  
**Software program storage requirements (continued)**

<b>Program</b> <b>(1K = 1024 words)</b>	<b>Version</b>	<b>Storage in KS</b>	<b>Comments</b>
FTC	711 R13	0	
	811/1011 R13-15	0	
	911 R13-14	0	
	1111/1211 R13-15	0	
DT12	811/1011 R14	8.55	
	911 R14	8.43	
	1011 R15	8.57	
	1111/1211 R14	6.11	
	1111/1211 R15	6.12	
JDMI	81 1/1011 R14-15	0	
	911 R14	0	
	1111/1211 R14-15	0	
ISDN	711 R13	Note 7	
	811/1011 R13	20.26	
	811/1011 R14	23.34	
	911 R13	20.00	
	911 R14	23.02	
	1011 R15	35.28	
	1111/1211 R13	14.75	
	1111/1211 R14	16.95	
	1111/1211 R15	26.06	
PRA	81 1/1011 R14-15	0	
	911 R14	0	
	1111/1211 R14-15	0	
ISL	711 R13		Note 7
	811/1011 R13-15	0.02	
	911 R13-14	0.01	
	1111/1211 R13-15	0.01	

— continued —

**Table 3**  
**Software program storage requirements (continued)**

<b>Program</b> (1K = 1024 words)	<b>Version</b>	<b>Storage in Ks</b>	<b>Comments</b>
NTWK SRVC	711 R13	Note 7-	
	811/1011 R13	3.57	
	811/1011 R14	3.97	
	911 R13	3.51	
	911 R14	3.91	
	1011 R15	5.42	
	1111/1211 R13	2.56	
	1111/1211 R14	2.85	
	1111/1211 R15	3.89	
DNXP	711 R13	0	
	811/1011 R13-15	0	
	911 R13-14	0	
	1111/1211 R13-15	0	
CDRE	711 R13	0	
	811/1011 R13-15	0	
	911 R13-14	0	
	1111/1211 R13-15	0	
ISDN AP	711 R13	0	
	811/1011 R13-15	0	
	911 R13-14	0	
	1111/1211 R13-15	0	
PR12	811/1011 R14	4.11	
	911 R14	4.03	
	1011 R15	4.19	
	1111/1211 R14	2.91	
	1111/1211 R15	2.97	

— continued —

Table 3  
Software program storage requirements (continued)

<b>Program</b> <b>(1K = 1024 words)</b>	<b>Version</b>	<b>Storage in Ks</b>	<b>Comments</b>
ACNT	811/1011 R14	0.61	
	911 R14	0.60	
	1011 R15	0.62	
	1111/1211 R14	0.43	
	1111/1211 R15	0.44	
ACD Account Package	7 11 R 13	0.61	
	811/1011 R13-14	0.61	
	911 R13-14	0.60	
	1111/1211 R13-14	0.43	

— continued —

**Table 3**  
**Software program storage requirements (continued)**

Program (1K = 1024 words)	Version	Storage in Ks	Comments
Total (base = resident + overlay area + firmware) .			
	711 R4	84.82	
	711 R5	87.96	
	711 R7	100.67	
	711 R8	104.41	
	711 R9	107.50	
	711 R10	114.00	
	711 R12	130.22	
	711 R13	141.05	
	811 R4	88.24	
	811 R5	93.31	
	811 R7	105.64	
	811 R8	107.95	
	811/1011 R9	134.73	
	811/1011 R10	119.84	
	811/1011 R12	122.81	
	811/1011 R13	145.52	
	811/1011 R14	165.42	
	911 R4	87.26	
	911 R5	93.42	
	911 R7	105.84	
	911 R8	108.04	
	911 R9	110.41	
	911 R10	115.42	
	911 R12	128.46	
	911 R13	139.66	
	911 R14	164.57	
	1011 R15	188.92	
	1111/1211 R8	85.66	
	1111/1211 R9	96.17	
	1111/1211 R10	100.42	
	1111/1211 R12	110.37	
	1111/1211 R13	114.94	
	1111/1211 R14	133.38	
	1111/1211 R15	164.57	

— continued —

**Table 3**  
**Software program storage requirements (continued)**

Program (1K = 1024 words)	Version	Storage in Ks	Comments
	No. of R/W Modules (base) (Note 2)		
	711	1 (56k)	
	811/1011	1 (56k)	
	911	1 (56k)	
	1111/1211	1 (56k)	
-continued —			

**Table 3**  
**Software program storage requirements (continued)**

Program (1K = 1024 words)	Version	Storage in Ks	Comments
Overflow (base) (Note 3) .			
	711 R4	28.82	
	711 R5	31.96	
	711 R7	44.67	
	711 R8	48.41	
	711 R9	51.50	
	711 R10	58.00	
	711 R12	74.22	
	711 R13	85.05	
	811 R4	32.94	
	811 R5	37.3 1	
	811 R7	49.64	
	811 R8	51.95	
	811/1011 R9	56.65	
	811/1011 R10	63.84	
	811/1011 R12	78.73	
	811/1011 R13	89.52	---
	911 R4	31.26	
	911 R5	37.42	
	911 R7	49.84	
	911 R8	52.04	
	911 R9	54.41	
	911 R10	59.42	
	911 R12	72.46	
	911 R13	83.66	
	1111/1211 R8	29.66	
	1111/1211 R9	40.16	
	1111/1211 R10	44.42	
	1111/1211 R12	54.37	
	1111/1211 R13	58.94	
— continued —			



**Table 3**  
**Software program storage requirements (continued)**

<b>Program (1K = 1024 words)</b>	<b>Version</b>	<b>Storage in Ks</b>	<b>Comments</b>
<b>Total of All Optional Packages (Note 4)</b>			
	<b>711 R4</b>	93.81	
	711 R5	100.26	
	711 R7	128.01	
	<b>711 R8</b>	142.29	
	711 R9	136.06	
	<b>711 R10</b>	162.92	
	711 R12	174.29	
	711 R13	186.74	
	811 R4	93.92	
	811 R5	100.80	
	811 R7	127.37	
	811 R8	144.01	
	<b>811/1011 R9</b>	135.12	
	<b>811/1011 R10</b>	161.20	
	<b>811/1011 R12</b>	194.96	
	81 1/1011 R13	209.93	
	<b>811/1011 R14</b>	232.04	
	911 R4	92.77	
	911 R5	99.68	
	911 R7	121.58	
	<b>911 R8</b>	142.39	
	911 R9	133.69	
	<b>911 R10</b>	159.96	
	911 R12	192.49	
	911 R13	207.76	
	911 R14	229.67	
	1011 R15	275.69	
	<b>1111/1211 R8</b>	112.29	
	<b>1111/1211 R9</b>	106.13	
	<b>1111/1211 R10</b>	126.92	
	<b>1111/1211 R12</b>	155.19	
	<b>1111/1211 R13</b>	154.70	
	<b>1111/1211 R14</b>	170.68	
	<b>1111/1211 R1</b>	207.69	

— continued —

**Table 3**  
**Software program storage requirements (continued).**

<b>Program</b> (1K = 1024 words)	<b>Version</b>	<b>Storage in K\$</b>	<b>Comments</b>
Overflow (base + all optional packages). (Note 4) .			
	<b>711 R4</b>	<b>122.63</b>	
	<b>711 R5</b>	<b>132.22</b>	
	<b>711 R7</b>	<b>172.68</b>	
	<b>711 R8</b>	<b>190.70</b>	
	<b>711 R9</b>	<b>187.56</b>	
	<b>711 R10</b>	<b>220.92</b>	
	<b>711 R12</b>	<b>248.51</b>	
	<b>711 R13</b>	<b>271.79</b>	
	<b>811 R4</b>	<b>126.16</b>	
	<b>811 R5</b>	<b>138.11</b>	
	<b>811 R7</b>	<b>177.01</b>	
	<b>811 R8</b>	<b>195.98</b>	..
	<b>811/1011 R9</b>	<b>191.77</b>	
	<b>811/1011 R10</b>	<b>225.04</b>	
	<b>811/1011 R12</b>	<b>273.69</b>	
	<b>811/1011 R13</b>	<b>299.45</b>	
	<b>811/1011 R14</b>	<b>397.46</b>	
	<b>911 R4</b>	<b>124.03</b>	---
	<b>911 R5</b>	<b>137.10</b>	
	<b>911 R7</b>	<b>171.42</b>	
	<b>911 R8</b>	<b>194.43</b>	
	<b>911 R9</b>	<b>188.10</b>	
	<b>911 R10</b>	<b>219.38</b>	
	<b>911 R12</b>	<b>264.95</b>	
	<b>911 R13</b>	<b>291.42</b>	
	<b>911 R14</b>	<b>394.25</b>	
	<b>1011 R15</b>	<b>464.61</b>	
	<b>1111/1211 R8</b>	<b>141.95</b>	
	<b>1111/1211 R9</b>	<b>146.30</b>	
	<b>1111/1211 R10</b>	<b>171.34</b>	
	<b>1111/1211 R12</b>	<b>209.56</b>	
	<b>1111/1211 R13</b>	<b>213.64</b>	
	<b>1111/1211 R14</b>	<b>304.06</b>	
	<b>1111/1211 R15</b>	<b>372.26</b>	
— continued —			

**Table 3**  
**Software program storage requirements (continued)**

Program (1K = 1024 words)	Version	Storage in Ks	Comments
ROM	711	8.0	
	<b>811/1011</b>	<b>8.0</b>	
	<b>911</b>	<b>8.0</b>	
	1111/1211	8.0	

Note **1** : On XL and **XN** systems, Read/Write fiware is represented by the set of High-Level **intrinsic**s.

Note **2** :**Only** 56K of the first program store is available.

**Note 3** :**Overflow** into protected data store or page **6, 5** and then **1**.

Note **4** :**Program** is first loaded into page 2, **then** overflow into **the** pages (if equipped) in the following sequences: page **6, 5, 1** (for non-enhanced systems); or page **8, 9, 10, 12, 13, 14, 6, 5, 1** (for enhanced systems).

Note **5** :**MCDR** (Mini CDR) is only available for **SL-1M**.

**Note 6** :**Resident** Programs include packages **0, 1** and 2.

Note **7** :**ISDN** features are not available on 711 version.

Note 8: TSET can only be used when DSET is available and uses the **same** memory.

Note 9: 1011 software must have "SLST" package turned ON.

**Table 4**  
**Unprotected data storage requirements**

Feature	Version	Storage in Words	Comments
<b>Fixed amount of storage required for system operation. .</b>			
	711 R4	3748	1 item only
	711 R5	3983	1 item only
	711 R7	4386	1 item only
	711 R8-14	4397	1 item only
	811 R4	3751	1 item only
	811 R5	3986	1 item only
	811 R7	4386	1 item only
	811 R8	3398	1 item only
	811/1011 R9-15	4400	1 item only
	911 R4	5632	1 item only
	911 R5	5867	1 item only
	911 R7	6267	1 item only
	911 R8	6279	1 item only
	911 R9-14	6281	1 item only
	1111/1211 R8-15	7487	1 item only
<b>For EACH of the following:</b>			
<b>500 and 2500 Sets</b>	711 R4-7	3.5	
	711 R8-10	4.5	
	811 R4-7	3.5	
	811/1011 R8-10	4.5	
	911 R4-7	3.5	
	911 R8-10	4.5	
	1111/1211 R8-10	4.5	
<b>500 sets</b>	711 R12-14	4.5	
	811/1011 R12-15	4.5	
	911 R12-14	4.5	
	1111/1211 R12-15	4.5	
<b>— continued —</b>			

Table 4  
 Unprotected data storage requirements (continued)

Feature	Version	Storage in Words	Comments
<b>2500 sets</b>	711 R12-14	5.5	
	811/1011 R12-15	5.5	
	911 R12-14	5.5	
	1111/1211 R12-15	5.5	
<b>2500 Sets (CFW)</b>	711 R4-7	4.5	
	711 R8-12	5.5	
	811 R4-7	4.5	
	811/1011 R8-12	5.5	
	911 R4-7	4.5	
	911 R8-12	5.5	
	111 1/1211 R8-12	5.5	
<b>SL-1 Sets (NDD)</b>	711	14.25	
	711 R13-14	16.25	
	811/1011	14.25	
	811/1011 R13-15	16.25	
	911 R4-8	14.25	
	911 R9-12	15.25	
	911 R13-14	16.25	
	1111/1211 <b>R8</b>	14.25	
	111 1/1211 R9-12	15.25	
	1111/1211 R13-15	16.25	
<b>SL-1 Sets (ADD)</b>	711	15.25	
	711 R13-14	18.25	
	811/1011	15.25	
	811/1011 R13-15	18.25	
	911 R4-8	15.25	
	911 R9-12	16.25	
	911 R13-14	18.25	
	1111/1211 <b>R8</b>	15.25	
	1111/1211 R9-12	16.25	
	1111/1211 R13-15	18.25	

— continued —

**Table 4**  
**Unprotected data storage requirements (continued)**

Feature	Version	Storage in Words	Comments
Add-on K/L Strips	711	10	
	811/1011	- 10	
	911	10	
	1111/1211	10	
Data Service Access TNs VMS Access TNs	711 R8-13		(Note 15)
	811/1011 R8-15		
	911 R8-14		
	1111/1211 R8-15		
Trunks	711		(Note 1)
	811/1011		
	911		
	1111/1211 R8-14		
Attendants	711 R4-7	89	
	711 R8-9	92	
	711 R10-12	93	
	711 R13-14	97	
	811 R4-7	95	
	811/1011 R8-9	98	
	811/1011 R10-12	99	
	811/1011 R13-14	103	
	911 R4-7	95	
	911 R8-9	98	
	911 R10-12	99	
	911 R13-14	103	
	1011 R15	107	
	1111/1211 R8-9	98	
	1111/1211 R10-12	99	
1111/1211 R13-14	103		
1111/1211 R15	107		

— continued —

**Table 4**  
**Unprotected data storage requirements (continued)**

Feature	Version	Storage in Words	Comments
<b>Customers</b>	711 R4-7	137	
	711 R8-12	152	
	711 R13	142	
	711 R14	144	
	811 R4-7	137	
	811/1011 R8-12	152	
	811/1011 R13	142	
	811/1011 R14-15	144	
	911 R4-7	137	
	911 R8-12	152	
	911 R13	142	
	911 R14	192	
	111 1/1211 R8-12	152	
	1111/1211 R13	142	
	111 1/1211 R14-15	192	
<b>Trunk Routes</b>	711		(Note 2)
	811/1011		
	911		
	1111/1211		
<b>Network-Local</b>	711 R4-14	63	
	811 R4	65	
	811 R5-7	66	
	811/1011 R8-15	66	
	911 R4	65	
	911 R5-14	66	
	1111/1211 R8--15	66	
<b>Network-RPE</b>	711 R4-13	80	
	811 R4	82	
	811 R5-7	83	
	811/1011 R8-15	83	
	911 R4	82	
	911 R5-14	83	
	1111/1211 R8-15	83	

— continued —

Table 4  
Unprotected data storage **requirements (continued)**

Feature	Version	Storage in Words	Comments
Juncture Group Pairs (Note 3)	711 R4-14	0	
	811 R4-7	0	
	811/1011 R8-15	0	
	911 R4-14	74	
	1111/1211 R8-15	74	
Peripheral Signaling	711 R4-14	36	
	811 R4-7	52	
	811/1011 R8-15	52	
	911 R4-14	52	
	1111/1211 R8-15	52	
Secondary Tape	711	539/541	
	811/1011	539/541	
	911	5391541	
	1111/1211	539/541	
TTY	711 R4-5		(Note 4)
	811 R7-14		
	811/1011 R8-15		
	911 R4-5		
	911 R7-14		
	1111/1211 R8--15		
Tone & Digit Switch	711	57	
	811/1011	59	
	911	59	
	1111/1211	59	
MF Sender	711	57	
	811/1011	59	
	911	59	
	1111/1211	59	

— continued —



**Table 4**  
**Unprotected data storage requirements (continued)**

<b>Feature</b>	<b>Version</b>	<b>Storage in Words</b>	<b>Comments</b>
<b>Conference</b>	<b>711 R4-9</b>	<b>141</b>	
	<b>711 R10-14</b>	<b>145</b>	
	<b>811 R4-7</b>	<b>143</b>	
	<b>811/1011 R8-9</b>	<b>143</b>	
	<b>811/1011 R10-15</b>	<b>147</b>	
	<b>911 R4-9</b>	<b>143</b>	
	<b>911 R10--14</b>	<b>147</b>	
	<b>1111/1211 R8-9</b>	<b>143</b>	
	<b>1111/1211 R10--15</b>	<b>147</b>	
<b>Digitone Receiver</b>	<b>711</b>	<b>6</b>	
	<b>811/1011</b>	<b>6</b>	
	<b>911</b>	<b>6</b>	
	<b>1111/1211</b>	<b>6</b>	
<b>LPIB</b>	<b>711</b>	<b>4x LPIB</b>	<b>1 item</b>
	<b>811/1011</b>	<b>4x LPIB</b>	<b>Note 5)</b>
	<b>911</b>	<b>4x LPIB</b>	
	<b>1111/1211</b>	<b>4x LPIB</b>	
<b>HPIB</b>	<b>711</b>	<b>4x HPIB</b>	<b>1 item</b>
	<b>811/1011</b>	<b>4 x HPIB</b>	<b>(Note 5)</b>
	<b>911</b>	<b>4x HPIB</b>	
	<b>1111/1211</b>	<b>4x HPIB</b>	
<b>PBXOB</b>	<b>711</b>	<b>4 x PBXOB</b>	<b>x # Periph. Signals</b>
	<b>811/1011</b>	<b>4 x PBXOB</b>	<b>(Note 5)</b>
	<b>911</b>	<b>4 x PBXOB</b>	
	<b>1111/1211</b>	<b>4 x PBXOB</b>	
<b>BCSOB</b>	<b>711</b>	<b>4 x BCSOB</b>	<b>x # Periph. Signals</b>
	<b>811/1011</b>	<b>4 x BCSOB</b>	<b>(Note 5)</b>
	<b>911</b>	<b>4 x BCSOB</b>	
	<b>1111/1211</b>	<b>4 x BCSOB</b>	

— continued —

**Table 4**  
**Unprotected data storage requirements (continued)**

Feature	Version	Storage in Words	Comments
ACD	711		(Note 6)
	811/1011		
	911		
	1111/1211		
ACD Enhancement	711		(Note 11)
	811/1011		
	911		
	1111/1211		
Extended Agent Observe	711	1	1 per ACD POS
	811/1011	1	
	911	1	
	1111/1211	1	
CMAC	711	534	1 item
	811/1011	534	
	911	534	
	1111/1211	534	
NARS/BARS/CDP	711		(Note 7)
	811/1011		
	911		
	1111/1211		

-- continued --

**Table 4**  
**Unprotected data storage requirements (continued)**

Feature	Version	Storage in Words	Comments
<b>Call Register</b>	711 R4	40	<b>(Note 8)</b>
	711 R5	41	
	711 R7	44	
	711 R8-9	45	
	711 R10-12	48	
	711 R13-14	61	
	811 R4	41	
	811 R5	42	
	811 R7	45	
	811/1011 R8-9	46	
	811/1011 R10-12	49	
	811/1011 R13-14	62	
	911 R4	41	
	911 R5	42	
	911 R7	45	
	911 R8-9	46	
	911 R10-12	49	
	911 R13-14	62	
	1011 R15	64	
	1111/1211 R8-9	46	
1111/1211 R10-12	49		
1111/1211 R13-14	62		
1111/1211 R15	64		
<b>CPRK</b>	711		<b>(Note 9)</b>
	811/1011		
	911		
	1111/1211		
<b>IMS</b>	711	28	<b>1 per list</b> <b>(Note 10)</b>
	811/1011	28	
	911	28	
	1011 R15	16	
	1111/1211	28	
	1111/1211 R15	16	

— continued —

Table 4  
Unprotected data storage requirements(continued)

Feature	Version	Storage in Words	Comments
<b>APL</b>	<b>711</b>	<b>179</b>	<b>1 per APL Link</b>
	<b>811/1011</b>	179	
	<b>911</b>	<b>179</b>	
	<b>1111/1211</b>	<b>179</b>	
<b>TDET</b>	<b>711</b>	<b>10</b>	
	<b>811 R4-5</b>	<b>10</b>	
	<b>811 R7</b>	11	
	<b>811/1011 R8-15</b>	11	
	<b>911 R4-5</b>	<b>10</b>	
	<b>911 R7-14</b>	11	
	<b>1111/1211 R8--15</b>	11	
<b>DTI</b>	<b>711</b>		<b>(Note 12)</b> "
	<b>811/1011</b>		
	<b>911</b>		
	<b>1111/1211</b>		
<b>ATM - Schedule Blk</b>	<b>711</b>		<b>(Note 13)</b>
	<b>811/1011</b>		
	<b>911</b>		
	<b>1111/1211</b>		
<b>ATM - Data Blk</b>	<b>711</b>		<b>(Note 13)</b>
	<b>811/1011</b>		
	<b>911</b>		
	<b>1111/1211</b>		
<b>Digital Sets</b>	<b>711</b>		<b>(Note 14)</b>
	<b>811/1011</b>		
	<b>911</b>		
	<b>1111/1211</b>		

— continued —

**Table 4**  
**Unprotected data storage requirements (continued)**

Feature	Version	Storage in Words	Comments
<b>Multi-Tenant</b>	711	32	
	811/1011	32	
	911	32	
	1111/1211	32	
<b>CSL</b>	711		<b>(Note 16)</b>
	811/1011		
	911		
	1111/1211		
— continued —			

**Table 4**  
**Unprotected data storage requirements (continued)**

Feature	Version	Storage in Words	Comments
DTI/DLI Loops	711		(Note 17)
	811/1011		
	911		
	1111/1211		
CUST	711	13	
	811/1011	13	
	911	13	
	1111/1211	13	
BGD	711	60	
	711 R13-14	66	
	811/1011	60	
	811/1011 R13-15	66	
	911	60	
	911 R13-14	66	
	1111/1211	60	
	1111/1211 R13-15	66	
BGD Disp	711	6x DNIS	1 item
	711 R13-14	9x DNIS	(Note 18)
	811/1011	6x DNIS	
	811/1011 R13-15	9x DNIS	
	911	6x DNIS	
	911 R13-14	9x DNIS	
	1111/1211	6x DNIS	
	1111/1211 R13-15	9x DNIS	
BGD/AWU Loop	711	100	1 item
	811/1011	100	
	911	100	
	1111/1211	100	

— continued —

**Table 4**  
**Unprotected data storage requirements (continued)**

<b>Feature</b>	<b>Version</b>	<b>Storage in Words</b>	<b>Comments</b>
<b>ISDN PRA</b>	<b>711 R12-14</b>		<b># of DCHIs</b> <b>(Note 19)</b>
	<b>811/1011 R12--15</b>		
	<b>911 R12-14</b>		
	<b>1111/1211 R12-14</b>		
<b>Overlay Data Space</b>	<b>711 R12-14</b>	260	
	<b>811/1011 R12-15</b>	260	
	<b>911 R12-14</b>	260	
	<b>1111/1211 R12-15</b>	260	
<b>ISL</b>	<b>711 R13-14</b>		<b># of DCHIs</b> <b>(Note 19)</b>
	<b>811/1011 R13-15</b>		
	<b>911 R13-14</b>		
	<b>1111/1211 R13-15</b>		
<b>ISDN Utility</b>	<b>711</b>		<b>(Note 21)</b>
	<b>811/1011</b>		
	<b>911</b>		
	<b>1111/1211</b>		
<b>ISDN PR12</b>	<b>711</b>		<b>(Note 19)</b>
	<b>811/1011</b>		
	<b>911</b>		
	<b>1111/1211</b>		
<b>JDMI/DTI2</b>	<b>711</b>		<b>Note 22</b>
	<b>811/1011</b>		
	<b>911</b>		
	<b>1111/1211 R13</b>		
<b>LEBLF</b>	<b>1011 R15</b>		<b>Note 23</b>
	<b>1111/1211 R15</b>		
<b>EOVF</b>	<b>1011 R15</b>		<b>Note 24</b>
	<b>1111/1211 R14</b>		

Note I : The size of the trunk block is **calculated** from:

$CT + X$  (words),

where:

$CT = 7$  words (3 average card block + 4 trunk timing block)

$X =$  (see the following table).

Trunk Types	Value of X	
	N or XN	Other
RLA	15	14
AUTOVON	8	8
ADM	14	13
Others	5	5
	10 (Note)	10 (Note)

Note: These numbers are for Release 12.



For Release 13 through 14, the size of the trunk block is calculated from:

$$CT + X \text{ (words)} + Y$$

where:

CT = 9 words (5 average card block + 4 trunk timing block)

X = (see the following table)

Y = 0 if the trunk belongs to a route which does not have CDR or which has CDR with dialed digits.

= 9 if the trunk belongs to a route which has CDR with outpulsed digits.

Trunk Types	Value of X	
	MS	Other
RAN	5	5
RLA	14	15
AUTOVON	8	8
ADM	15	15
Others (includes ISA)	10	10

**Note 2 :** The size of the route block is calculated from:

24 + ceiling (number of **members/16**) (words).

**Releases 12 and 13**

27 + ceiling (number of **members/16**) (words).

**Releases 14 through 15**

43 + ceiling (number of **members/16**) (words)

Note 3 : The number of Junctor Group Pairs is  $(N \times (N-1))/2$  in a system with N network groups.

**Note 4 :** The size of the TTY blocks is calculated from:

**For Releases 4 and 5:**

$141 + x$  (words),

where:  $x = 8$  for CDR TTYs; 128 otherwise.

**For Releases 7 through 15:**

$t + x$  (words),

**where:**

$t = 16$  (size (TTYIOBLOCK) + 128 (TTY output buffer) = 144

and  $x =$  the following table

	Input Buffer	Data	Output Q
CDR link:	128		
HS link:	<b>128 +</b>	15	
APL link:	<b>128 +</b>	(179 +	<b>4)</b>
PMS Link:	<b>20 +</b>	2	
other:	8		

**Note 5 :** The size of the Input/Output buffers is specified in “messages”. Each message uses 4 words of unprotected data store. The recommended size for I/O buffers is:

LPIB (Low Priority Input Buffers) = 96 messages

HPIB (High Priority Input Buffers) = M, **LE:16** messages  
 S, MS: 16 messages  
 N, VLE: 32 messages  
 XL: 16 x # of groups  
**XN:32** x # of groups

PBXOB (Non SL1 Output Buffers) = 160 messages

BCSOB (SL1 Output Buffers) = 160 messages

*Note 6 :* For ACD features the following additional storage is required (total for system):

$$(K0 \times [(K1 \times CROUT) + (K2 \times CPID) + (K3 \times CDN) + CTM + (K4 \times CRT)]) + (K5 \times CCUST) + (K6 \times DN) + (K7 \times PID)$$

*where* the multiplication constants (**K<sub>i</sub>**) are:

**K<sub>0</sub> = 0** if ACD-C package is not equipped,

**K<sub>0</sub> = 1** if ACD-C package is equipped.

**K<sub>1</sub> = 32** size (U\_ACD\_RTE\_EXTN) (=20)  
+ word offset (TRUNK-SEIZE-TIME) (=12)

**K<sub>1</sub> = 32** size (U\_ACD\_BLOCK\_EXTN) (=78)  
(R12)

**K<sub>1</sub> = 46** size (U\_ACD\_RTE\_EXTN) (=28)  
(R13-15) + word offset (TRUNK-SEIZE-TIME) (=18)

if long report is selected.  
**K<sub>2</sub> = 11** size (U\_ACD\_POS\_BASIC) (= 11)

**K<sub>2</sub> = 11** size (U\_ACD\_POS\_BASIC) (= 13)  
(R12)

**K<sub>2</sub> = 14** size (U\_ACD\_POS\_BASIC) (= 14)  
(R13-15)

if short report is selected  
**K<sub>2</sub> = 22** size (U\_ACD\_POS\_EXTN) (= 22)

**K<sub>2</sub> = 22** size (U\_ACD\_POS\_EXTN) (= 39)  
(R12)

**K<sub>2</sub> = 42** size (U\_ACD\_POS\_EXTN) (= 42)  
(R13-14)

**K<sub>3</sub> = 50** size (U\_ACD\_BLOCK\_EXTN) (=50)  
(R4-5)

**K<sub>3</sub> = 66** size (U\_ACD\_BLOCK\_EXTN) (=66)  
(R7-9)

---

K3 =74	size (U_ACD_BLOCK_EXTN) (=74) for R10
K3 =78 (R12-15)	size (U_ACD_BLOCK_EXTN) (=78)
K4 = 25	size (U_ACD_IOAREA) (=25)
K5 = 71 (R4-5)	size (U_ACD_PRINT) (=15) + size (U_ACD_RTE_SYS) (=13) + size (U_ACD_SYS_Q_POS) (=43)
K5 = 79 (R7-10)	size (U_ACD_PRINT) (=15) + size (U_ACD_RTE_SYS) (=13) + size (U_ACD_SYS_Q_POS) (=51)
K5 = 79 (R12)	size (U_ACD_PRINT) (= 19) + size (U_ACD_RTE_SYS) (= 34) + size (U_ACD_SYS_Q_POS) (= 57)
K5 = 114 (R13-15)	size (U_ACD_PRINT) (= 20) + size (U_ACD_RTE_SYS) (= 34) + size (U_ACD_SYS_Q_POS) (= 60)
K6 = 90 (R4-5)	size (U-ACD-BLOCK) (=90)
K6 = 100 (R7-8)	size (U-ACD-BLOCK) (=100)
K6 = 117 (R10)	size (U_ACD_BLOCK) (=117)
K6 = 118 (R12)	size (U-ACD-BLOCK) (=123)
K6 = 123 (R13-14)	size (U-ACD-BLOCK) (=123)
K6 = 128 (R15)	size (U-ACD-BLOCK) (=128)
K7 = 24	size (U_ACD_POS) (=24)

---

**K7 = 29** size (**U\_ACD\_POS**) (= 29)  
**(R13-15)** + 2 for DN Expansion  
+ 1 for **ACD\_ACNT\_CODE**

**K8 = 48** for NT, RT, and XT systems  
**(R13)**

**K8 = 48** for XT, and NT  
**(R14-15)**

**K8 = 32** for XN, and ST systems  
**(R13-15)**

and the variables are represented by:

CCUST = total no. of customers with ACD-C package  
CDN = total no. of ACD **DNs** for ACD-C customers  
CPID = total no. of AGENT POSITIONs for ACD-C customers  
CROUT = total no. of ACD routes in ACD-C customers  
CTM = total no. of TRUNK members in CROUT  
DN = total no. of ACD **DNs** (for the system)  
PID = total no. of AGENT POSITIONs (for the system)  
CRT = total no. of ACD CRTs.

*Note 7* : The **unprotected** data store requirements (on a per-customer basis) for **NARS/BARS/CDP**:

**2 x (8 x RL + 6 x NCOS) Release 4**

2 x (12 x RL + 6 x NCOS) Releases 5-8

2 x (16 x RL + 6 x NCOS) Releases 9-12

If FCBQ & OHQ is equipped:

**2 x (11 x RL + 10 x NCOS) Release 4**

2 x (17 x RL + 10 x NCOS) Releases 5-8

2 x (21 x RL + 10 x NCOS) Releases 9-12

**Releases 13 through 15**

If OHQ or MCBQ is equipped:

**RLSIZE + NCOSIZE + QROUTSIZE**

Otherwise:

**RLSIZE + NCOSIZE**

*where:*

<b>RL</b>	= number of route lists
<b>RLSIZE</b>	= <b>2 x (45 x RL) (FCBQ &amp; OHQ equipped)</b> = 2 x (40 x RL) (otherwise)
<b>NCOS</b>	= number of NCOS defined
<b>NCOSIZE</b>	= <b>2 x (1045 x NCOS) (RLBQ &amp; OHQ equipped)</b> = 2 x (6 x NCOS) (otherwise)
<b>QROUTE</b>	= number of routes with either CBQ or OHQ
<b>QROUTSIZE</b>	= <b>2 x (7 x QROUTE)</b>

Note 8 : N, the recommended number of Call Registers is:

$$N = (T + 815)/33.8 + M$$

where:

$$T = A/2 \times C \times 1.42 - B.$$

M = the number of ACD incoming trunks.

A = the total voice loop traffic in CCS.

B = M x 1 (1 is average CCS per ACD trunk).

C = the total call register traffic factor

The Total Call Register Traffic Factor is equal to 1 + any of the following factors:

0.037 if CDR Charge Account

0.074 if Authorization Code

0.037 if Parallel CDR Ports Per Customer

0.150 if **NARS/BARS/CDP**

0.150 if FCBQ and OHQ

0.033 if ACD RAN

0.019 if Telset Messaging

0.140 if **IMS**

0.083 if Ring Again

0.033 if Music Trunk

0.067 if CPRK

0.003 if NFCR

0.039 if ESN Signalling

0.0 if Stored Number **Redial** (negligible impact)

0.184 if IVMS (with **R4-5**)

0.044 if individual hold (with **R4-5**)

## Assumptions:

- (1) The peak day traffic =  $1.42 \times$  ABSBH traffic for business offices.
- (2) All outgoing calls require authorization (worst case assumption).
- (3) An additional call register is required for 20 s to hold the **authorization** code.
- (4) 50% of outgoing calls use the charge account feature (worst case assumption).
- (5) An additional call register is required for 20 s to hold the charge account.
- (6) The additional holding time of the call register for CDR purposes is 5 seconds.
- (7) The average number of ports used in the multiple CDR ports feature is 2.
- (8) A call register is required for each incoming ACD trunk.
- (9) The intra-office ration  $R = 0$  (worst case assumption).
- (10) The number of originating calls = the number of terminating calls.
- (11) The blocking peak of the day traffic is **P0.01**.
- (12) The average **NARS/BARS** call takes 20 s to dial and 20 s to complete outpulsing and delay for answer.
- (13) The average holding time of a RAN is 15 s.
- (14) The average Telset Message takes 6 s to dial and 20 s to complete outpulsing and delay for answer.
- (15) The average IMS call takes 8 s to dial, 15 seconds ringing and 40 s with message attendant. During the busy hour, 60% of tenninating calls are unanswered, of which 50% require IMS.
- (16) A call register is required for active Ring Again call.



- (17) Music Trunk holding time is 30 s.
- (18) Average Call Park holding time is 1 min.
- (19) Average holding time for New Flexible Code Restriction is 4 s.
- (20) ESN Signalling Feature holding time is 15 s and 35% of calls need signalling feature.
- (21) The average IVMS call takes 8 s to dial, 15 s ringing, 10 s listening to greeting and 50 seconds leaving message. During the busy hour, 60% of terminating calls are unanswered, of which 50% require IVMS **(R4-5)**.
- (22) Individual Hold call holding time is 30 s **(R4-5)**.

**Note 9** : Size per item for Call Park

k + ceiling (s/16), for **UCALL\_PARK\_BLOCK**

**where:**

s = number of System Park **DNs** per customer

$$k = 2 \quad \frac{\text{UCPRKBLOCKLENGTH}(1.0)}{\text{FREE\_DN\_INDEX}(0.5) \times \text{NUM\_SYS\_PRK\_USED}(0.5)}$$

**Note 10 : IMS Unprotected Memory Requirements**

Release 4:

LINK Q TBL HDR = 1 word

LINK OQ TBL = 16 words

APL REQ TO SENDS = 1 word

APL RDY TO SENDS = 1 word

APL MONITOR S = 10 words

APL MAINTENANCE S = 1 word

APL PRINT MODE S = 1 word

APL PRT MSG S = 1 word

APL PRT PACK S = 1 word

MSG MONITOR S = 1 word

PACK MONITOR S = 1 word

APL INTERCEPT S = 1 word

**APL I LINK SEL S = 1 word**

APL LINK DATA = 179 words x N

QUEUE DATA BLOCK = 4 words x N

N = # of APL links defined in CFN Block

Total Unprotected       $12 + (182 \times N)$  words or  $(0.117 + 0.178 \times N) K$   
 N = # of APL links defined in CFN Block

**Releases 5 and 7:**

LINK OQ TBL = 16 words

APL LINK DATA = 178 words x N

QUEUE DATA BLOCK = 4 words x N

N = # of APL links defined in CFN Block

**Releases 8 through 15:**

LINK OQ TBL = 16 words

APL LINK DATA = 179 words x N

QUEUE DATA BLOCK = 4 words x N

N = # of APL links defined in CFN Block

Total Unprotected (Releases 5 through 14)

(16 + (182 x N)) words or (0.016 + 0.178 x N) K words

N = # of APL links defined in CFN Block.

Total Unprotected (**Releases 15**)

(16 + (183 x N)) words or (0.016 + 0.178 x N) K words

N = # of APL links defined in CFN Block.

Note **11** : For Releases 4 and 5: ACD Enhancement — For each customer with historical reports active add:

62 words for the customer (U ACD PRINT)

24 words per ACD Group (U ACD BLOCK)

11 words per Route that auto terminates on an ACD group (U ACD RTE BLK)

2 words per ACD position (U ACD POS)

plus 11 words per ACD position if short reports are active on the customer.

For Releases 7 through 14: ACD Enhancement — AN ACD — C customer (see Note 6).

**Note 12** : DTI unprotected memory requirement:

**Releases 4 and 5**

13 + 9 x number of DTI loops.

**Releases 7 through 15 (per DTI loop)**

local network loop data + DTI data

= 66 (for 811 and 911 machines) + 9 = 75 words

= 63 (for all other machines) + 9 = 72 words.

Note 13 : In Releases 7 through 15, there is no **unprotected** data store impact.

**Note 14** : Unprotected data store for digital set voice port:  
**Releases 7 and 8**

	<b>N/XN (words)</b>	<b>Others (words)</b>
M2009	25.25	24.25
M2018	35.25	34.25
M2112	25.25	24.25
M2317	36.25	35.25
M3000	46.25	45.25

Unprotected data store for digital set data port with Digit Display Class Of Service (COS). Note that data ports without digital COS require one word less than those with Digit Display.

	<b>N/XN (words)</b>	<b>Others (words)</b>
M2009	26.25	25.25
M2018	36.25	35.25
M2112	26.25	25.25
M2317	16.25	15.25
M3000	16.25	15.25

**Releases 9 through 12**

	<b>N/XN (words)</b>	<b>Others (words)</b>
<b>M2009</b>	18.25	17.25
M2018	29.25	-28.25
M2112	20.25	19.25
<b>M2317</b>	36.25	35.25
M3000	46.25	45.25

Unprotected data store for digital set data ports. Note that data ports without digit class of service require one word less than those with digit display.

**Releases 13 through 15**

	<b>With Digit Display (size in words)</b>	<b>Without Digit Display (size in words)</b>
M2009	21.25	19.25
M2018	32.25	30.25
M2112	23.25	21.25
M2317	38.25	36.25
M3000	48.25	46.25

*Note 15* : The additional unprotected data store for a virtual terminal (DS access TN or VMS access TN) is dependent on the shelf/card to which the terminal is assigned. For all machine types, the increments (in words) are as follows:

**Releases 8 through 12**

DS/VMS Access TN    **Preallocated Card 14**  
   Otherwise 15.25

**Releases 13 through 15**

**DS/VMS Access TN**    **Preallocated** Card 15  
 Otherwise 16.25

Where a preallocated card is one of the following shelf/cards:

O/1 - 0/7, 1/1 - 1/8, 2/1 - 2/8, or 3/8 on a DLI loop.  
 See Note 17.

**Note 16** : CSL Unprotected Data is comprised of:

**Per system (with CSL package, Release 8):**

CSL IQ HDRTBL + Queues	= 3 + (3 x 4) words
CSL OQ HDRTBL	= 16 words
CSL MONITOR BLK	= 112 words
Total	= 143 words.

**Per system (with CSL package, Releases 9 through 15):**

CSL IQ HDRTBL + Queues	= 3 + (3 x 4) words
CSL OQ HDRTBL	= 16 words
Total	= 31 words.

**Per CSL Link (Releases 8 through 15):**

U CSL DATA BLK	= 123 words
CSL I ARRAY BLK	= 128 words
CSL O ARRAY BLK	= 128 words
QUEUE DATA BLOCK	= 4 words
Total	= 383 words.

**Note 17** : DLI unprotected memory requirements (per DLI loop):

= DTI requirements (Note 12) + DLI data + preallocated card data  
 = 75 (811 and 911 machines) + 18 + 120 words. = 213 words  
 = 72 (all other machines) + 18 + 120 = **210** words.

**Note 18** : NDIS is the number of display messages defined in Overlay 17 for the Background Terminal.

*Note 19* : Each DCHI consists of the following unprotected data blocks:

1. DCH U BLOCK = 43 words  
     **44 for R13 and R14**  
     47 for R15
2. Output request buffers = 5 x # of OTBFs
3. Output buffer = 261 words
4. Input buffer = 261 words
5. Unprotected call reference table = 2 + M
6. Unprotected message link table = 1 + M

M is computed as follows:

- (a) If PRI 111 nn is defined for the DCH link:  
     **M = 24 x (max (NN) + 1)**
- (b) If PRI 111 nn is not defined and the backup D-channel is defined for the DCH link:  
     **M = 24 x 2**
- (c) If PRI 111 nn and the backup D-channel are not defined:  
     **M = 24.**
- (d) If DCHI is in ISL mode:  
     M = maximum number of ISL trunks defined
- (e) If DCHI is in SHARED mode:  
     M = (a) or (b) or (c) + maximum number of ISL trunks defined.
- (f) PR12 ONLY: unprotected data block of 65 words.

*Note 20* : SIZE (BG\_INPUT AREA) (= 15)  
 + SIZE (BGW\_WORK\_ENTRY) (= 26)  
 + SIZE (BGS\_SCAN\_ENTRY) (= 25)  
 Total=66

---

**Note 21:** One bit map table for **TCAP per system.**

Size of bit map (**words**) $1/16$  x number of **CRs** defined per system

Traffic for TCAP4 words per Application ID (1)

**Note 22 :** Each DTI loop requires the following:

<b>DTI_UDATA_LPBLK</b>	<b>47</b> words
<b>DTI2_UDATA_CATD</b>	<b>9</b> words

**Note 23:** Two words in the attendant unprotected data block per attendant console is required. This is accounted for in the attendant data block size.

If Enhanced Busy Lamp field (**EBLF**) is ON, a bit is required to indicate idle/busy status of each DN. This equals 7 (16 bit) words per hundreds group defined.

**Note 24 :** Enhanced Overflow requires an additional 4 words per ACD DN.





**Table 5**  
**Protected data storage requirements**

Feature	Version	Storage in Words	Comments
<b>Fixed amount of storage required for system operation.</b>			
	711 R4	2981	
	711 R5	3077	
	711 R7	3253	
	711 R8	3249	
	711 R9-14	3250	
	811 R4	3109	
	811 R5	3148	
	811 R7	3253	
	811 R8	3305	
	811/1011 R9-14	3306	
	911 R4	3379	
	911 R5	3460	
	911 R7	3568	
	911 R8	3620	
	911 R9-14	3621	
	1011 R15	3461	
	1111/1211 R8	2981	
	1111/1211 R9-14	2982	
	1111/1211 R15	3092	
<b>For EACH of the following:</b>			
500 and 2500 Sets	711 R4-7		(Note 1)
	711 R8-10		
	811 R4-7		
	811/1011 R8-15		
	911 R4-7		
	911 R8-14		
SL-1 Sets	1111/1211 R8-15		(Note 2)
	711		
	811/1011		
	911		
	1111/1211		

— continued —

**Table 5**  
**Protected data storage requirements (continued)**

Feature	Version	Storage in Words	Comments
Add-on K/L strips	711	10/rs	
	811/1011	10/rs	
	911	10/rs	
	1111/1211	10/rs	
Data Service Access TNs	711 R8-14		(Note 29)
VMS Access TNs	811/1011 R8-15		
	911 R8-14		
	1111/1211 R8-15		
Template Head Table	711	1 + # Templates	
	811/1011	1 + # Templates	
	911	1 + # Templates	
	1111/1211	1 + # Templates	
Templates	711 R4-5	3 + # Entries	(Note 21)
	711 R7-14	4 + # Entries	
	811 R4-7	4 + # Entries	
	811/1011 R8-15	4 + # Entries	
	911 R7-14	4 + # Entries	
	1111/1211 R8-15	4 + # Entries	
Trunks	711 R4-9	10.5	(Note 22)
	711 R10-12	13.5	
	711 R13-14	16.5	
	811 R4-7	10.5	
	811/1011 R8-12	13.5	
	811/1011 R13-15	16.5	
	911 R4-9	10.5	
	911 R10-12	13.5	
	911 R13-14	16.5	
	1111/1211 R8-9	10.5	
	1111/1211 R10-12	13.5	
	1111/1211 R13-15	16.5	

— continued —

**Table 5**  
**Protected data storage requirements (continued)**

Feature	Version	Storage in Words	Comments
Attendants	711		(Note 3)
	<b>811/1011</b>		
	<b>911</b>		
	<b>1111/1211</b>		
Customers	711 R4	161	(Note 38 for) Releases 13 through 15)
	711 R5	166	
	711 R7	181	
	711 R8	203	
	711 R9	201	
	711 <b>R10</b>	207	
	711 R12	211	
	811 R4	161	
	811 R5	166	
	811 R7	181	
	811 R8	203	
	<b>811/1011 R9</b>	201	
	<b>811/1011 R10</b>	207	
	81 1/1011 R12	211	
	911 R4	161	
	911 R5	166	
	911 R7	181	
	911 R8	203	
	911 R9	201	
	911 <b>R10</b>	207	
	911 R12	211	
	<b>1111/1211 R8</b>	203	
	<b>1111/1211 R9</b>	201	
<b>1111/1211 R10</b>	207		
<b>1111/1211 R12</b>	211		
1011 R15	46		
<b>1111/1211 R15</b>	46		

— continued —

**Table 5**  
**Protected data storage requirements (continued)**

Feature	Version	Storage in Words	Comments	
Trunk Routes	711 R4	31	# of Routes (Note 35 for Release 14 through 15)	
	711 R5	33		
	711 <b>R7-8</b>	34		
	711 R9	35		
	711 <b>R10</b>	37		
	711 R12	43		
	711 R13	50		
	811 R4	31		
	811 R5	33		
	811 <b>R7-8</b>	34		
	811/1011 R9	35		
	811/1011 <b>R10</b>	37		
	811/1011 R12	43		
	811/1011 R13	50		
	911 R4	31		
	911 R5	33		
	911 <b>R7-8</b>	34		
	911 R9	35		
	911 <b>R10</b>	37		
	911 R12	43		
	911 R13	50		
		<b>1111/1211 R8</b>		34
		<b>1111/1211 R9</b>		35
	<b>1111/1211 R10</b>	37		
	<b>1111/1211 R12</b>	43		
	<b>1111/1211 R13</b>	50		
Code Restrictions	711	51	x # Code Restriction Routes	
	811/1011	51		
	911	51		
	1111/1211	51		
INFCR	711		(Note 17)	
	811/1011			
	911			
	1111/1211			

-continued —

**Table 5**  
**Protected data storage requirements (continued)**

Feature	Version	Storage in Words	Comments
Peripheral Signaling	711	30	1 item
	811/1011	30	
	911	30	
	1111/1211	30	
Network Group	711	16	
	811 R4-7	32	
	811/1011 R8-15	32	
	911	38	
	1111/1211	38	
Network-LOC	711 R4-5	68	
	811 R4-5 <sup>14</sup>	70	
	811 R7	70	
	811/1011 R14-15	70	
	911 R4-5	68	
	911 R7-14	70	
	1111/1211	70	
Network-RPE	711 R4-5	71	
	711 R7-14	73	
	811 R4-5	71	
	811 R7	73	
	811/1011 R8-15	73	
	911 R4-5	71	
	911 R7-14	73	
	1111/1211	73	
TDS	711	2	
	811/1011	2	
	911	2	
	1111/1211	2	

— continued —

**Table 5**  
**Protected data storage requirements (continued)**

Feature	Version	Storage in Words	Comments
MF Sender	711	2	
	811/1011	2	
	911	2	
	1111/1211	2	
Conference	711	2	
	811/1011	2	
	911	2	
	1111/1211	2	
Digitone Receiver	711	8	
	811/1011	8	
	911	8	
	1111/1211	8	
DN Translator (Note 4)	711		
	811/1011		
	911		
	1111/1211		
DIG Translator (Note 5)	711		
	811/1011		
	911		
	1111/1211		
SCL Master Head Table for	711	1 + Number of Lists	1 item
	811/1011	1 + Number of Lists	(Note 39 for
	911	1 + Number of Lists	Releases 13
	1111/1211	1 + Number of Lists	through 15)
SCL Head Table	711		1 perlist
	811/1011		(Note 15)
	911		
	1111/1211		

— continued —

**Table 5**  
**Protected data storage requirements (continued)**

Feature	Version	Storage in Words	Comments
<b>SCL</b>	711		#SC Lists (Note 6)
	811/1011		
	911		
	1111/1211		
<b>CAS—Main</b>	711	0	#Customers
	811/1011	0	
	911	0	
	1111/1211	0	
<b>CAS—Remote</b>	711	15	#Customers
	811/1011	15	
	911	15	
	1111/1211	15	
<b>BARS</b>	711		#Customers (Note 7)
	811/1011		
	911		
	1111/1211		
<b>FTC</b>	711		32 Tables (Note 42)
	811/1011		
	911		
	1111/1211		
<b>EFTC</b>	711		32 Tables (Note 44)
	811/1011		
	911		
	1111/1211		
<b>NARS</b>	711		#Customers (Note 8)
	811/1011		
	911		
	1111/1211		

— continued —



Table 5  
Protected data storage requirements(continued)

Feature	Version	Storage in Words	Comments
CDP	711		# Customers (Note.9)
	811/1011		
	911		
	1111/1211		
ACD	711		# Customers (Note 10)
	811/1011		
	911		
	1111/1211		
Group DND	711		# Customers (Note 11)
	811/1011		
	911		
	1111/1211		
DISA	711		# Customers (Note 12)
	811/1011		
	911		
	1111/1211		
AUTH	711		# Customers (Note 13)
	811/1011		
	911		
	1111/1211		
HIST	711		1 item (Note 14)
	811/1011		
	911		
	1111/1211		
CPRK	711		# Customers (Note 4)
	811/1011		
	911		
	1111/1211		

— continued —

Table 5  
Protected data storage requirements (continued)

Feature	Version	Storage in Words	Comments
IMS	711	370	1 per list
	811/1011	370	(Note 16)
	911	370	
	1111/1211	370	
NFCR	711		1 per customer
	811/1011		(Note 17)
	911		
	1111/1211		
Soft Memory	711	35	1 item
	811/1011	35	
	911	35	
	1111/1211	35	
TDET	711	3	# TDET
	811/1011	3	
	911	3	
	1111/1211	3	
DTI	711 R4, 7-14		1 item
	811 R5-7		(Note 18)
	811/1011 R8-15		
	911 R5, 7-14		
	1111/1211		
AMP	711 R4, 7-14		# Modem Pools
	811 R5, 7		(Note 19)
	811/1011 R8-15		
	911 R5-14		
	1111/1211		

-- continued --

**Table 5**  
**Protected data storage requirements (continued)**

Feature	Version	Storage in Words	Comments
Multiple Office Code Screening	711 R4, 7-14 811 R5-7 811/1011 R8-15 911 1111/1211		1 per location code (if defined) (Note 20)
M2009 Telephone	711 811/1011 911 1111/1211		# telephones (Note 23)
M2018 Telephone	711 811/1011 911 1111/1211		# telephones (Note 25)
M2112 Telephone	711 811/1011 911 1111/1211		# telephones (Note 24)
M23 17 Digital Set	711 811/1011 911 1111/1211		# of sets (Note 3 1)
M3000 Touchphone	711 811/1011 911 1111/1211		# telephones (Note 26)
Multi-Tenant	711 811/1011 911 1111/1211		# of Customers (Note 27)

— continued —

**Table 5**  
Protected data storage requirements (continued)

Feature	Version	Storage in Words	Comments
ATM Schedule Block	711		(Note 28)
	811/1011		
	911		
	1111/1211		
ATM Data Block	711	12	# ATM Routes
	811/1011	12	
	911	12	
	1111/1211	12	
DLI	711		# DLI Loops (Note 18)
	811/1011		
	911		
	1111/1211		
ESDI	711	16 + Nx 7	N = # Ports
	811/1011	16 + Nx 7	
	911	16 + Nx 7	
	1111/1211	16 + Nx 7	
CSL	711	2	# Links
	711 R13-14	4	
	811/1011	2	# Links
	811/1011 R13-15	4	
	911	2	
	911 R13-14	4	
	1111/1211	2	# Links
	1111/1211 R13-15	4	# Links
VAS	711	16 + N	N = # Servers
	811/1011	16 + N	
	911	16 + N	
	1111/1211	16 + N	

— continued —

**Table 5**  
**Protected data storage requirements (continued)**

Feature	Version	Storage in Words	Comments
VAS DSDN	711		# Customers (Note 30)
	811/1011		
	911		
	1111/1211		
CPND	711		Per system (Note 32)
	811/1011		
	911		
	1111/1211		
LLC	711	5	
	811/1011	5	
	911	5	
	1111/1211	5	
Auxiliary Customer	711	187	# Customers
	811/1011	187	
	911	187	
	1111/1211	187	
ISDN PRA	711 R12-14		# PRI (Note 33)
	811/1011 R12-15		
	911 R12-14		
	1111/1211 R12-15		
ISDN PRA (Note 34)	711 R12		# DCHI
	811/1011 R12-13		
	911 R12-13		
	1111/1211 R12-13		
ISDN PRA	711 R12-14		SID tables (Note 36)
	811/1011 R12-15		
	911 R12-14		
	1111/1211 R12-15		

— continued —

**Table 5**  
**Protected data storage requirements (continued)**

Feature	Version	Storage in Words	Comments
<b>AWU Count</b>	<b>711</b>	<b>144</b>	
	<b>811/1011</b>	<b>144</b>	
	<b>911</b>	<b>144</b>	
	<b>1011 R15</b>	<b>288</b>	
	<b>1111/1211</b>	<b>144</b>	
	<b>1111/1211 R15</b>	<b>288</b>	
<b>ISL</b>	<b>711 R12-14</b>		<b>#DCHI</b>
	<b>811/1011 R12-15</b>		<b>(Note 37)</b>
	<b>911 R12-14</b>		
	<b>1111/1211 R12-15</b>		
<b>ISDN PR12</b>	<b>711</b>		<b># PR12</b>
	<b>811/1011</b>		<b>(Note 33)</b>
	<b>911</b>		
	<b>1111/1211</b>		
<b>ISDN PR12</b>	<b>711</b>		<b># DCHI</b>
	<b>811/1011</b>		<b>(Note 34)</b>
	<b>911</b>		
	<b>1111/1211</b>		
<b>Pretranslation</b>	<b>711</b>		<b># PREXL</b>
	<b>811/1011</b>		<b>(Note 40)</b>
	<b>911</b>		
	<b>1111/1211</b>		
<b>JDMI/DTI2</b>	<b>711</b>		<b>(Note 41)</b>
	<b>811/1011</b>		
	<b>911</b>		
	<b>1111/1211</b>		
<b>EBLF</b>	<b>1011</b>		<b>(Note 44)</b>
	<b>1111/1211</b>		
<b>EOVF</b>	<b>1011 R15</b>		<b>(Note 45)</b>
	<b>1111/1211 R15</b>		

**Note 1**: The size of the protected line block for **PBX** telephones is determined from the following:

Basic Line Block	4 words Release 4
	5 words Releases 5 through 9
	6 words in Release <b>10</b>
	7 words in Releases 12 through 15
Basic Line Block (ODAS)	7 words Releases 4 and 5
	8 words Releases 7 through 12
	10 words Releases 13 through 15
Card Block Component	1.5 words

The key layout portion of the template requires  $(2 + \mathbf{nf}/\mathbf{rs})$  words in Release 4 or,  $(4 + \mathbf{nf}/\mathbf{rs})$  words in Releases 5 through 15, where “nf” is the number of features defined for the telephone, and “rs” is the number of telephones sharing the same template.

In addition to the basic line block, each feature requires extra data space as follows:

Feature	R4-5	R7-12	R13	R14-15
Associate Set	—	2 words	2 words	2 words
Automatic Wake-Up		1 word	1 word	1 word
Call Forward Key (4-24 digits)	1-6 words	1-6 words		1-6 words
Call Forward by Call Type		2 words	2 words	2 words
Call Party Name Display		1 word + 3 to 13 words (6-26 characters, 2 characters per word)	1 word + 4 to 14 words (6-26 characters, 2 characters per word)	1 word + 4 to 14 words (6-26 characters, 2 characters per word)
CFNA/Hunting Key	1 word	1 word	2 words	2 words
Dial Intercom Key	1 word	1 word		1 word
DN Key	1 word	1 word	2 words	2 words
EFD/EHT DN	—	1 word (R12)	2 words	2 words
Hot Line DN (1-31 digits)	—	1-8 words	2-10 words	2-10 words
— continued —				



Feature	R4-5	R7-12	R13	R14-15
Enhanced Hot Line (1-31 digits)		2-10 words (R10-12)	2-10 words	2-10 words
Last Number Redial (3-32 digits)		1 word (R8)	1 word	
(4-32 digits)		1-8 words (R9-10)	1-8 words	1-8 words
Manual Line	—	1 word	2 words	2 words
Message Center DN	—	1 word	2 words	2 words
Message Registration		1 word	1 word	1 word
Pretranslation Enhancement				1/2 word (for 255 calling groups)
SCI/CCOS/RMS		1 word	1 word	1 word
Speed Call Controller	—	1 word	1 word	1 word
Speed Call Key	1 word	—	—	
Speed Call User	—	1 word	1 word	1 word
— continued —				

Feature	R4-5	R7-12	R 13	R14-15
Stored Number <b>Redial</b> (4-32 digits)	1-8 words	1-8 words	1-8 words	1-8 words
System Speed Call User	—	1 word	1 word	1 word
Tenant Number	—	1 word	1 word	1 word

Note 2 : The size of the protected line block for SL-1 telephones is determined from the following:

Basic Line Block	7 words in Release 4 8 words in Release 5 9 words in Release 7 10 words in Releases 8-13 13 words in Release 14-15
Basic Line Block (ODAS)	10 words Releases 4 and 5 12 words Releases 7-12 16 words Releases 13-15
Card Block Component	1.5 words

The key layout portion of the template in Release 4 requires  $12/rs$  words, where  $rs$  = the number of telephones sharing the same template.

The key layout portion of the template, in Releases 5 through 15, requires  $(4 + \text{the number of key lamp strips} \times 10)/rs$  words, where  $rs$  = the number of telephones sharing the same template.

132 Memory calculations

In addition to the basic **line** block requirement, each feature requires extra data space as follows:

Feature	R4-5	R7-12	R13	R14-15
ACD Agent Key	1 word	1 word	1 word	1 word
ACD Display Queue Key	1 word	1 word	2 words	2 words
ACD <b>Interflow</b> Key	1 word	1 word	2 words	2 words
ACD IN-CALLS key	9 words	11 words	11 words	11 words
ACD Night Service DN			2 words	2 words
<b>Autodial</b> Key (4-32 digits)	1-8 words			
<b>Autodial</b> Key (4-24 digits)		1-6 words	1-6 words	1-6 words
Automatic Wake-Up		1 word (R10-12)	1 word	1 word
Call Forward Key (4-24 digits)	1-6 words	1-6 words	1-6 words	1-6 words
Call Forward by Call <b>Type</b>		2 words (R10-12)	2 words	2 words
-- continued --				

Feature	R4-5	R7-12	R13	R14-15
CFNA DN	1 word	1 word	2 words	2 words
Conference <b>Autodial</b>				1-6 words
Conference Hotline				3-10 words
Conference Speed Call				1 word
DIG Key	1 word	1 word	1 word	1 word
DN Key	1 word	1 word	2 words	2 words
EFD/EHT DN		1 word	2 words	2 words
Flash Call Key	1 word	1 word	1 word	1 word
Flash Override Call Key	1 word	1 word	1 word	1 word
Hot Line (1-31 digits)				3-10 words
Hot Line, Enhanced		2-10 words (R10-12)	2-10 words	
Hunt DN	1 word	1 word	2 words	2 words
Immediate Call Key	1 word	1 word	1 word	1 word

— continued —

Feature	R4-5	R7-12	R13	R14-15
Last Number Redial (4-32 digits)		1 word (R8)	1 word	1-8 words
		1-8 words (R9-12)		
Message Center DN		1 word	2 words	2 words
Message Registration		1 word (R10)	1 word	1 word
Park Key	1 word	1 word	1 word	1 word
Pretranslation Enhancement				1/2 word (for 255 calling groups)
Priority Call Key	1 word	1 word	1 word	1 word
Private Line Key		1 word	2 words	2 words
SCI/CCOS/RMS (131 digits)		1 word (R10-12)	1 word	
Signal Key	1 word	1 word	2 words	2 words
Speed Call Controller		1 word	1 word	1 word
Speed Call Key	1 word			

— continued —

Feature	R4-5	R7-12	R13	R14-15
Speed Call User		1 word	1 word	1 word
Stored Number Redial <b>Key</b> (4-32 digits)	1-8 words	1-8 words	<b>1-8</b> words	<b>1-8</b> words
Tenant Number		1 word	1 word	1 word
Time and Date Key		1 word	1 word	1 word
Voice Call Key	1 word	1 word	<b>2</b> words	<b>2</b> words

Note 3 : The size of the protected line block for attendant telephones is determined from the following:

Card Block Component	3 words
Primary Line Block	14 words in Release 4 15 words in Releases 5 through 12 21 words in Releases 13 and 14 24 words in Release 15
Secondary Line Block	4 words 3 words in Release 15

In addition to the basic lineblock, each **feature** requires extra data space as follows:

Feature	Requirements
<b>Autodial</b> Key	<b>8</b> words
	<b>6</b> words in Releases 7-15)
Flash Call Key	1 word ( <b>R8-12</b> )
Flash Override Call Key	1 word
Group DND Key	1 word
Immediate Call Key	1 word
Paging Key	1 word
	<b>2</b> words in Releases 13-1 5
Priority Call Key	1 word
Speed Call Key	1 word
Store Number Redial Key	<b>8</b> words



*Note 4* : Prior to **Release 13**, the memory requirements for **the Directory Number Translator** are (in words of protected data store):

$(2 \times S) + AS + 12 \times (1 + N1 + N2 + N3)$   
 $+ AD \times (2 + AI \times 2) + (DD \times 2) + SPDN$   
 + number of listed DN  
 + 1 per defined DN  
 + 16 (+ 64 **with Releases 8 and 9**)  
     (+ 65 with Release 10)  
     (+ 66 with Release 12)  
     if any attendants are defined  
 + 1 if special service prefix defined  
 + 3 per **NARS/BARS** access code defined  
 + 7 if RSANI access code defined  
 + 1 if CAS Hold DN is defined  
 + 2 if CAS RLT DN is defined  
 + 3 per CDP steering code defined  
 + 2 per defined Test Line DN  
 + 1 per defined ACD-DN  
 + 1 per defined DIG Group  
**+ 1 per SL1 DN**

**Releases 13 through 15:**

$(2 \times S) + AS + 12 \times (1 + N1 + N2 + N3 + N4 + N5 + N6)$   
 $+ AD \times (2 + AI \times 2) + (DD \times 2) + SPDN$   
 + number of listed **DNs**  
 + 2 per defined DN  
 + 16 (+ 66)  
     if any attendants are defined  
 + 1 if special service prefix defined  
 + 3 per **NARS/BARS** access code defined  
 + 10 if RSANI access code defined  
 + 2 if CAS Hold DN is defined  
 + 2 if CAS RLT DN is defined  
 + 3 per CDP steering code defined  
 + 2 per defined Test Line DN  
 + 1 per defined ACD-DN  
 + 1 per defined DIG Group  
**+ 1 per SL1 DN**



where:

S = number of different DN appearing on SL- 1 telephones, **500/2500** telephones mixed with SL- 1 telephones, and private line **500/2500** telephones

AS = number of appearance of DN within S

**N1** = number of different **first** digit in the numbering plan

N2 = number of different sequence of the **first** two digits in the numbering plan (if DN is more than 2 digits)

N3 = number of different sequence of the first three digits in the numbering plan (if DN is more than 3 digits)

N4 = number of different sequence of the first four digits in the numbering plan (if DN is more than 4 digits)

**N5** = number of different sequence of the first five digits in the numbering plan (if DN is more than 5 digits)

N6 = number of different sequence of the first six digits in the numbering plan (if DN is more than 6 digits)

AD = number of ACD-DNs

AI = number of ACD POSITION-IDs in each ACD-DN

DD = number of DISA-DNs

SPDN = number of System Park **DNs**

Note 5 : The protected data store requirements for the Dial Intercom feature for each customer using the package are as follows:

$$1 + Gx (1 + 2x M)$$

where:

G = number of groups

M = number of members in each group

**Release 14 through 15:**

$$(n + 1) + (x x (2 + (yx2) ) )$$

**where:**

n = maximum number of dial intercom groups in Overlay 15

x = actual number of dial intercom groups configures

y = average number of members in each dial intercom group

Note 6 : The size of a Speed Call List is:

$$((NB - 1) x 256) + (NBR x WE)$$

**where:**

NB and WE is calculated as described in Note 15 under the Speed Call List Head Table

NBR is the remainder of the calculation to determine NB, which was

$$NB = EL/EB$$

When  $EL/EB$  is zero, use the following formula:

$$((NB - 1) x 256) + (EB x WE)$$

The following quick reference chart facilitate the programming of the Speed Call List memory requirements. Locate the intersect point of the required DN and list sizes to determine the number of words needed.

**Speed Call Quick Reference Chart**

List Size	DN Size							
	4	8	12	16	20	24	28	31
1	6	7	8	9	10	<b>11</b>	1 2	13
5	10	15	20	25	30	35	40	45
10	15	25	35	45	55	65	75	85
20	25	45	65	85	105	125	145	165
25	30	55	80	105	130	155	180	205
30	35	65	95	125	155	185	215	245
40	45	85	125	165	205	245	290	326
50	55	105	155	205	255	310	360	406
60	65	125	185	245	312	370	340	486
70	75	145	215	290	362	430	500	568
75	80	155	230	310	402	460	538	608
80	85	165	245	330	442	490	576	648
90	95	185	280	370	462	556	646	728
100	105	205	310	410	512	616	716	808
200	205	412	615	820	1026	1226	1431	1612
250	255	511	765	1020	1284	1531	1787	2013
300	312	619	920	1226	1541	1841	2147	2416
400	412	826	1226	1636	2055	2542	2863	3220
500	512	1026	1531	2041	2570	3063	3573	4023
600	619	1234	1853	2708	3085	3678	4289	4827
700	719	1441	2147	2862	3599	4289	5004	5631
750	769	1541	2297	3062	3856	4594	5359	6033
800	826	1648	2452	3268	4113	4904	5720	6435
900	926	1855	2667	3678	4628	5515	6431	7240
1000	1018	1955	3050	4083	5142	6125	7146	8043

Note 7 : The protected data store requirements for BARS (on a per-customer basis) are:

#### Release 4

$$137 + 2.73 \times (\text{HNPA} + \text{NPA}) + 2.73 \times (1\text{HNPA} + 1\text{NPA}) + \text{RL} \times (8 + 3 \times \text{RLE}) + \text{DME} \times (3 + \text{I/4}) + \text{FCAS}$$

#### Releases 5 and 7

$$137 + 2.73 \times (\text{HNPA} + \text{NPA}) + 2.73 \times (1\text{HNPA} + 1\text{NPA}) + \text{RL} \times (8 + 3 \times \text{RLE}) + \text{DME} \times (3 + \text{I/4}) + \text{FCAS} + \text{SDRR} \times (3 + 2 \times \text{SDE}) + \text{ITGE}$$

#### Releases 8 through 12

$$16 + \text{SUM} + \text{RL} \times (8 + 3 \times \text{RLE}) + \text{DME} \times (3 + \text{I/4}) + \text{FCAS} + \text{SDRR} \times (3 + 2 \times \text{SDE}) + \text{ITGE}$$

#### Releases 13 and 14

$$\text{BASICESN} + \text{SUM} + \text{RL} \times (8 + 3 \times \text{RLE}) + \text{DME} \times (3 + \text{I/4}) + \text{FCAS} + \text{SDRR} \times (3 + 2 \times \text{SDE}) + \text{ITGE}$$

#### Release 15

$$\text{BASICESN} + \text{SUM} + \text{RL} \times (8 + 3 \times \text{RLE}) + \text{DME} \times (4 + \text{I/4}) + \text{FCAS} + \text{SDRR} \times (3 + 2 \times \text{SDE}) + \text{ITGE}$$

where:

$$\text{SUM} = 11 \times \frac{[(10 \times \text{R}) \times \text{n}] - 1}{(10 \times \text{R}) - 1} \text{ words}$$

**n** = maximum level of tree ( $n > 0$ )

**HNPA** = number of NXX in the home NPA of the SL-1

I =	the average number of digits that must be inserted as part of digit manipulation
NPA=	number of NPA (area codes) in the North American dialing plan
IHNPA=	number of 1 + NXX in the home NPA of the SL-1
INPA =	number of 1 + NPA (area codes) in the North American dialing plan
R =	the rate of digits equipped in each level of the tree (translator)
RL=	the number of route lists
RLE=	the average number of route lists entries per route list
DME =	the number of distinct digit manipulation entries (included the default 0th entry)
FCAS =	$(N + 1) + N(M + 1) + MN[4 + (100P + 15)/16]$

where:

N = the number of defined FCAS tables  
M = the average number of NPA codes per table  
P = the average number of first digit of NXX codes

SDRR =	Number of supplemental digit restricted/recognized blocks defined for NPA, NXX, LOC, SPN
SDE =	Average number of SDRR entries for each SDRR block
ITGE =	9 x ITEI; where ITEI = the number of Incoming <b>Trunk</b> Group Exclusion Index
BASICESN =	SIZE (ESN_DATA_BLOCK)+SIZE (NCTL_DATA_BLOCK

$$129 + 305 = 434$$

$$\text{SIZE (ESN\_TRAN-BLOCK)} = 11$$

This formula is based on the assumption that the **NPA/NXX** translation tree is half full and distributed evenly. This should represent the typical case. For more precise calculation, use NABS formula.

Note 8 : The protected data store requirements for NABS (on a per-customer basis) are:

#### Release 4

$$137 + 12 \times (1 + A1 + A2) + 12 \times (A3 + A4)$$

$$+ 12 \times (1 + B1 + B2) + 12 \times (B3 + B4)$$

$$+ 4 \times RN + RL \times (8 + 3 \times RLE) + DME$$

$$\times (3 + I/4) + LOC \times 6 + FCAS + SCC$$

#### Releases 5 and 7

$$137 + 11 \times (1 + A1 + A2) + 11 \times (A3 + A4)$$

$$+ 11 \times (1 + B1 + B2) + 11 \times (B3 + B4)$$

$$+ SDRR \times (3 + 2 \times SDE) + RL \times (8 + 3 \times RLE) + DME$$

$$\times (3 + I/4) + LOC \times 6 + FCAS + SCC + ITGE + MDID$$

#### Releases 8 through 12

$$16 + \text{SUM1} + \text{SUM2}$$

$$+ SDRR \times (3 + 2 \times SDE) + RL \times (8 + 3 \times RLE) + DME$$

$$\times (3 + I/4) + LOC \times 6 + FCAS + SCC + ITGE + MDID$$

#### Releases 13 and 14

$$\text{BASICESN} + \text{SUM1} + \text{SUM2}$$

$$+ SDRR \times (3 + 2 \times SDE) + RL \times (8 + 3 \times RLE) + DME$$

$$\times (3 + I/4) + LOC \times 6 + FCAS + SCC + ITGE + MDID$$

#### Release 15

$$\text{BASICESN} + \text{SUM1} + \text{SUM2}$$

$$+ SDRR \times (3 + 2 \times SDE) + RL \times (8 + 3 \times RLE) + DME$$

$$\times (4 + I/4) + LOC \times 6 + FCAS + SCC + ITGE + MDID$$

where:

**SUM1** = (SUM of network translator 1)

**SUM2** = (SUM of network translator 2)

**SUM** = 
$$1 \times \frac{[(10 \times R) \times n] - 1}{(10 \times R) - 1} \text{ words}$$

**n** = maximum level of tree ( $n > 0$ ).

**A1** = number of different **first** digit in network translator 1.

**A2** = number of different sequence of the **first** two digits in the non **1+** number in network translator 1.

**A3** = number of different second digits in the **1+** number in network translator 1.

**A4** = number of different sequence of the second and third digits in the **1+** number in network translator 1.

**B1** = number of different first digit in network translator 2.

**B2** = number of different sequence of the first two digits in the non **1+** number in network translator 2.

**B3** = number of different second digits in the **1+** number in network translator 2.

**B4** = number of different sequence of the second and third digits in the **1+** number in network translator 2.

**R** = is the rate of digits equipped in each level of the tree (translator).

**RL** = the number of route lists.

**RLE** = the average number of route lists entries per route list.

**DME** = the number of distinct digit manipulation entries (included the default 0th entry).

I = the average number. of digits that must be inserted as part of digit manipulation.

LOC = number of on-net or virtual locations.

FCAS =  $(N + 1) + N(M + 1) + MN[4 + (100P + 15)/16]$

**where:**

N = the number of defined FCAS tables

M = the average number of NPA codes per table

P = the average number of first digit of NXX codes

SCC = Number of entries in the SCC table.

SDRR = Number of supplemental digit restricted/recognized blocks defined for NPA, NXX, LOC, SPN.

SDE = Average number of SDRR entries for each SDRR block.

ITGE = 9 x ITEI; where ITEI = the number of Incoming Trunk Group Exclusion Index.

MDID = (2 x number of total office codes) + (2 x number of total DID ranges regardless of which office codes they belong to). Maximum of 20 ranges or office codes can be **defined** per location code, (i.e., 1 office code and 20 ranges, or 20 office codes and 1 range for each office code).

BASICESN =  

$$\text{SIZE(ESN\_DATA\_BLOCK)} + \text{SIZE(NCTL\_DATA\_BLOCK)}$$

$$129 + 305 = 434$$



**Note 9** : Prior to Release 13, the protected data store requirements for CDP (on a per-customer basis) are:

$$137 + SC \times 2 + RL \times (8 + 3 \times RLE) + DME \times (3 + I/4)$$

**Releases 13 through 15**

$$BASICESN + SC \times 3 + RL \times (8 + 3 \times RLE) + DME \times (3 + I/4)$$

where:

- SC = number of steering codes
- RL = the number of route lists
- RLE = the average number of route lists entries per route list
- DME = the number of distinct digit manipulation entries
- I = the average number of digits that must be inserted as part of digit manipulation.

$$BASICESN = \underset{129}{\text{SIZE(ESN\_DATA\_BLOCK)}} + \underset{305}{\text{SIZE(NCTL\_DATA\_BLOCK)}} = 434$$

CDP Steering Codes also occupy SL- 1 DN tree spaces. This portion of data store is calculated in DN tree formula (See Note 4).



**Note 10** : The ACD feature requires the following additional data store (total for system):

For ACD-C not equipped

$$(K3 \times DN) + (K4 \times PID) + AID + (K5 \times CUST)$$

Simplified

$$(46 \times DN) + (12 \times PID) + AID + (3 \times CUST)$$

For ACD-C equipped

$$[K1 + (K2 \times CCUST)] + (K3 \times DN) + (K4 \times PID) + AID + (K5 \times CUST)$$

Simplified

$$[25 + (8 \times CCUST)] + (46 \times DN) + (12 \times PID) + AID + (3 \times CUST)$$

where the multiplication constants (Ki) are:

$$K1 = 25 \quad \text{size (P\_ACD\_IO\_BLK) (=25).}$$

$$K2 = 8 \quad \text{size (P\_ACD\_SCHED\_BLK) (=8).}$$

$$K3 = 46 \quad \text{size (P\_ACD\_BLOCK) (=32)} \\ (R4-5) \quad + \text{ ptr to blk from ACD LIST (=1)} \\ + \text{ word offset (ACD-POS-TN) (=13).}$$

$$K3 = 47 \quad \text{size (P\_ACD\_BLOCK) (=33)} \\ (R7-8) \quad + \text{ ptr to blk from ACD LIST (=1)} \\ + \text{ word offset (ACD-POS-TN) (= 13).}$$

$$K3 = 48 \quad \text{size (P\_ACD\_BLOCK) (=34)} \\ (R10) \quad + \text{ pointer to block from the ACD List (=1)} \\ + \text{ word offset (ACDPOS-TN) (=13).}$$

$$K3 = 49 \quad \text{size (P\_ACD\_BLOCK) (=39)} \\ (R12) \quad + \text{ pointer to block from the ACD List (=1)} \\ + \text{ word offset (ACD-POS-TN) (=13).}$$

<b>K3 = 57</b> <b>(R13-14)</b>	size ( <b>P_ACD_BLOCK</b> ) (=40) + pointer to block from the ACD List (=1) + word offset ( <b>ACD_POS_TN</b> ) (=16).
<b>K4 = 12</b>	size ( <b>P_ACD_KEY_DATA</b> ) (=11) + store for <b>ACD_POS_TN</b> (=1).
<b>K4 = 14</b> <b>(R13-14)</b>	size ( <b>P_ACD_KEY_DATA</b> ) (=13) + store for <b>ACD_POS_TN</b> (=1).
<b>K5 = 3</b>	header ( <b>ACD_LIST</b> ) (=1) + header ( <b>ACD_AGENT_ID_TBL</b> ) (=2).

and the variables are represented by:

AID = total no. of AGENT **IDs** (for the system)  
 CCUST = total no. of customers with ACD-C package  
 CUST = total no. of customers with ACD-C/D packages  
 DN = total no. of ACD **DNs** (for the system)  
 PID = total no. of AGENT POSITIONs (for the system).

Note **II**: The protected store requirements for Group DND (on a per-customer basis) are:

$$1 + G \times (1 + M)$$

Release 13 through 15:

$$1 + G \times (1 + 2 \times M)$$

where:

G = number of groups

M = number of members in each group (2 words per member for **R13-14**)

**Note 12:** The **protected** store requirements for DISA (on a per-customer basis) are:

$$1 + (\text{DN} \times 6)$$

**Release 13 through 15**

$$1 + (\text{DN} \times 7) \text{ ----- } 1 + (\text{DN} \times 7)$$

**where:**

DN = number of DISA-DNs.

**Note 13:** The protected store requirements for Authorization Code (on a per-customer basis) are:

$$1250 + (A \times ((L/4 \times 128) + 64)) + (B \times (1018 + (C \times 32)))$$

**Releases 13 through 15:**

$$1308 + (A \times ((L/4 \times 128) + 64)) + (B \times (1018 + (C \times 32)))$$

*where:*

L = digit length

T = **total** authcode

A = number of **overflow** blocks

B = number of **auth** blocks

C = number of resolution blocks per auth block.

**For L less than 4 or L greater than 7**

$$A = (T/128) + 1$$

$$B = C = 0.$$

**For L in the range of 4 - 7**

$$A = ((0.2 \times T)/128 + 1)$$

$$B = ((0.8 \times T)/1000 + 1)$$

$$C = 8$$

**Note 14** : History file buffer can be **1—64K per** customer option.

**Note 15** : For System Speed Call List (**SCL**) Head Table:

$$3 + \text{NB}/4 + \text{NB} \text{ (round } \text{NB}/4 \text{ up)}$$

$$\text{NB (no. of blocks)} = \text{EL}/\text{EB} \text{ (round any remainder up)}$$

where:

EL = entries per list (given),

EB = entries per block, **256/WE** (round up remainder)

**where:**

WE = words per entry, **DNS/4** (round up)

where: DNS is DN size (given).

**Note 16** : IMS protected memory requirements:

**APP\_SIZE\_TBL** = 10 words

**MSG\_SIZE\_TBL** = 40 words

**LTN\_TN\_TBL** = 255 words

**LTN\_LINK\_TBL** = 65 words

---

Note 17: New **Flexible** Code Restriction (**NFCR**) requires the following memory requirements:

- 1) A 129 word block that contains:
  - (a) A 128 word table that contains the pointers to **the.FRL** block for each route.
  - (b) A pointer to the tree root address table.
- 2) A table that contains the pointers to the NFCR trees. Its length is defined by the maximum number of trees (defined in the customer data block).
- 3) Four words are required for each route that has defined FRL codes.
- 4) Storage for customer defined trees. Amount of memory used depends on the size of the code restriction trees the customer has defined.

It is possible to calculate an upper bound for the amount of memory that a tree is using by applying the following formula:

- 1) The **INIT** condition occupies 12 words, or 14 words in **R12-14**.
- 2) For each digit sequence after the **INIT** condition:
  - (a) If the digit sequence is greater than 1 digit, memory required = (3 x number of digits) + 4.
  - (b) If the digit sequence has a count field, memory required for digit sequence increases by 1.
  - (c) If the digit sequence is from a **BYPS**, memory required for digit sequence increases by 1.

Note **18** : **DTI/DLI Protected** Data Store requirements:

**Releases 4 and 5**

PDD-BLOCK =	12 words
PAD-TABLE =	36 words
MISCELLANEOUS =	2 words
TOTAL=	50 words

**Release 7**

= PDD-BLOCK + (N x P\_DTI\_TSET\_BLOCK) + (T x local network data)

$$= 18 + (N \times 10) + (T \times 70)$$

**Releases 8 through 15**

= PDD-BLOCK + (N x P\_DTI\_TSET\_BLOCK) + (T + L) x local network data+ (L x (P LOOP DLI + preallocated card data))

$$= 18 + (N \times 10) + [(T + L) \times 70] + [L \times (19 + 144)]$$

where: N = the number of threshold sets  
 T = the number of DTI loops  
 L = the number of DLI loops.

Note 19 : The protected data store requirements for the modem pools on a per route basis (Modem Data Block):

$$1 + (1 \times M)$$

where:

M = greatest member number in modem **pool** route

Other AMP **data** store requirements have been added to their respective fields.

Note 20 : The size of the protected multiple office code screening line block is determined from the following:

2 words for each NXX code defined

2 words for each range defined (maximum\_ 20 ranges per location code • 80 words **pds**).

Note 21 : Templates are incremented in blocks of 10 words.

Note 22 : The trunk block size is 11.5 words with ODAS,  
or 14.5 words in Releases 10 and 12,  
or 19.5 words in Releases 13 and 15.

Note 23 : Requirements for voice/data port are the same as an SL-1 basic telephone (Note 2) except the key layout portion of the template requires:

**Before Release 9:**

$(24 + \# \text{ of non-key features})/\#$  of telephones sharing the same template-

**After Release 9:**

$(10 + \# \text{ of non-key features})/\#$  of telephones sharing the same template.

Note 24 : Requirements for voice/data port are the same as an SL-1 basic telephone (Note 2) except the key layout portion of the template requires:

**Before Release 9:**

$(24 + \# \text{ of non-key features})/\#$  of telephones sharing the same template.

**After Release 9:**

$(12 + \# \text{ of non-key features})/\#$  of telephones sharing the same template.



Note 25 : Requirements for voice/data port are the same as an SL- 1 basic telephone (Note 2) except the key layout portion of the template requires:

**Before Release 9:**

$(34 + \# \text{ of non-key features})/\#$  of telephones sharing the same template.

**After Release 9:**

$(21 + \# \text{ of non-key features})/\#$  of telephones sharing the same template.

**Note 26** : Requirements for voice/data port are the same as an SL-1 basic telephone (Note 2) except the key layout portion of the template requires  $(44 + \# \text{ of non-key features})/\#$  of telephones sharing the same template. For M3000 data port, requirements are the same as an SL- 1 basic set (see Note 2).

Note 27 : Protected-data store **required** by the Multi-Tenant Service feature includes the following:

1028 words per customer that enables Tenant Service for:

**Releases 4, 5 and 7:**

= size (P\_TENANT\_PTRS) (=644)  
+ size (TEN\_CPG\_ORDLS) (=256)  
+ size (RTE\_CPG\_ORDLS) (= 64)  
+ size (CPG\_DEFS) (= 64)

**Releases 8-14:**

= size (P\_TENANT\_PTRS) (=644)  
+ size (TEN\_CPG\_ORDLS) (=256)  
+ size (RTE\_CPG\_ORDLS) (= 64)  
+ size (CPG\_DEFS) (=256)

32 words per Tenant access map  
= size (ACCESS-ARRAY)

32 words per Outgoing Route access map  
= size (ACCESS-ARRAY)

**Note 28** : Protected data store requirements for ATM schedule block are as follows:

**Releases 4, 5 and 7:**

$$24 + ((9 \times NC + 1) \times NH)$$

**Releases S-15:**

$$24 + ((9 \times NC + 1) \times NH) + 13 \times AR$$

where:

NC = Number of Customers.

NH = Number of hours to be scheduled.

AR = Number of routes to be tested.

Note 29 : For all machine types, the additional protected data store for a virtual terminal (DS access TN or VMS access TN) is exactly the same as for an SL-1 set, with one exception. For any of the two TN types, the Card Block Component is dependent on the shelf/card to which the terminal is assigned. The component is 0 if the TN is on a preallocated card, or 1.5 words otherwise. A preallocated card may be one of the following shelf/cards: 0/1 - 0/7, 1/1 - 1/8, 2/1 - 2/8 or 3/8 on a DLI loop. See Note 18.

Note 30 : The protected data store requirement (in words) for VAS Data Services per customer, for each customer that has at least one DSDN, is:

$$= \text{DSDN\_VAS\_TBL} + (\text{DSDN-LIST} \times \text{N})$$

$$16 + (39 + \text{N})$$

where:

N = the number of VAS for which at least one DSDN is defined.

**Releases 10 and 12**

$$= \text{DSDN\_VAS\_TBL} + (\text{DSDN LIST} \times \text{N})$$

$$16 + (248 \times \text{N})$$

**Release 14 and 15**

$$= \text{DSDN\_VAS\_TBL} + (\text{DSDN\_LIST} \times \text{N})$$

$$16 + (76 \times \text{N})$$

where:

N = number of VAS for which at least one DSDN is defined.

Note 31 : Requirements for a Voice/Data port are the same as an SL- 1 basic set (see Note 2), except that the key **layout** portion of the template requires 34 + # of non-key features / # of sets sharing the same template.

For M2317 data ports, **the** requirements are the same as the SL- 1 basic set (see Note 2).

**Note 32** : Protected data **store** requirements for CPND **per** system in words is:

$$32 + (10 \times C) + (1 \times SP) + (11* \times DIG) + ((1 + N/2) \times NA) + (1 \times SL)$$

where:

C = number of customers

SL = number of non-PBX **DNs** with or without name defined  
(including trunk routes, ACD **ATTN**, and SL- 1)

SP = number of single appearance PBX **DNs** with name defined

DIG = number of DIG Groups  
\* = 101 for **2-digit** DIG Groups

N = Name length

NA = number of Names.

Note 33 : For each PR loop configured, add 5 words for the P-PREP-BLOCK to the PTERM LOOP-BLOCK.

**Note 34** : Each system that has **DCHIs** shares **P\_DCH\_TBL** which has 16 words in length. Each DCHI consists of the following protected data blocks:

**P\_DCH\_BLOCK** = 23 words

**Releases 13 and 14:**

**P\_DCH\_BLOCK** = 25 words

**Release 15:**

**P\_DCH\_BLOCK** = 26 words

Protected call reference table =  $1 + (24 \times \text{\# of PRI loops controlled by DCHI})$ . If DCHI is in PRA mode, add the following:

Protected call reference table =  $1 + (\text{maximum number of ISL trunks defined})$  if DCHI is in ISL mode

Protected call reference table =  $1 + (24 \times \text{\# of PRI loops controlled by DCHI}) + (\text{maximum number of ISL trunks defined})$  if DCHI is in SHARED mode.

**Note 35** : For each ISA route configured for **IFC = ESS4**, add 2 words for the **ISA-SRVCBLOCK**.

With Releases 14 and 15, if **IFC = ESSY**, add 4 words for the **ISA-SRVCBLOCK**.

**Note 36** : A pointer named **ISA\_SID\_MTHPTR** has been added to fix memory. This pointer is set to nil when SID is not defined for ISDN routes.

A data block of 32 words is defined and accessed through this pointer if **SID** is defined for at least one ISDN route in the system. This data block contains pointer to **SID** tables for each customer. The structure mapping onto this data block is **ISA\_CUSTID\_TPTR**.

A data block of 64 words is **allocated** for each customer if at least one route is defined to have SID. The structure mapping onto this data block is **ISA\_SID\_RT\_LIST**.

Note 37 : Protected ISL Trunk TN table = **1+** maximum number of ISL Trunks defined.

**Note** 38 : The protected customer data per customer defined is as follows:

$$B + (X \times (P + A))$$

where:

P = Protected customer data block (255) (262 in Release 15)

A = auxiliary customer data (14)

B = 1000 for XN, XT, RT, and NT machines  
320 for all other machine types

X = number of customer groups defined

If background terminal is equipped, an additional auxiliary data block is allocated which requires 35 words. This brings the total requirement to 305 words.

Note 39 : No protected storage is required unless the system is equipped with the Speed Call package (66) and the entry to MSCL prompt in Overlay 17 is greater than 0. In this case, the protected memory required for SCL main header table is:

$$\text{words required} = N + (1 \times A)$$

where:

N = 1 (number of header words)

A = number of SCL as defined in Overlay 17 (**MSCL** prompt)

Note **40** : For each customer, an additional 255 words is needed for **PREXL\_SCLN** in pool CDB (compool).

Note 41 : The protected data store requirements for **DTI2** is as follows:

<b>DTI2_SYSTEM_DATA</b>	9 words
<b>DTI2_SCAT_NT</b>	16 words
<b>DTI2_SCTA</b>	16 words
<b>DTI2_PCADA_NT</b>	16 words
<b>DTI2_PCADA</b>	16 words

Note 42 : There are 32 pointers to FTC protected structures. Each FTC table has 90 words

Note 43 : There are 256 pointers to **EFTC** protected structures. Each EFTC table has an additional 27 words.

Note 44: A bit is required in the customer data block to indicate EBLF allowed/denied. A bit is required in the protected attendant block if attendant consoles have the Console **GGraphics** Module (CGM) configured. Additional memory is required only if EBLF is ON. 104 words are allocated in the fixed protected memory even if EBLF is not used.

Words required:

$$x + ((z - 3) \times y \times 11)$$

where:

x = number of customers with EBLF

y = average number of hundreds groups per customer

z = average DN length (4, 5, 6, 7)



*Note 45* : **EOVF** requires the following **in-Release 15**:

per target table	113 words
per source table	174 words
per ACD DN	6 words

The words required for the source table **are** allocated for every target ACD DN.

---

## List of terms

---

**AA**

Attendant Administration

**AAB**

Automatic Answerback

**ACDA**

ACD Basic

**ACDB**

ACD Advanced

**ACDC**ACD Management **Reoprts****ACDD**

ACD Auxiliary data System

**ACDR**

AUTOVON CDR

**AIOD**

Automatic Identification od Inward Dial

**AMP**

Automated Modem Pooling

**ANI**Automatic Number **Identification**ANI Route Selection

<b>ANIR</b>	<b>ANI</b> Route Selection
<b>AOP</b>	Attendant Overflow Position
<b>ATVN</b>	AUTOVON
<b>AUTH</b>	Authorization code
<b>AWU</b>	Automatic Wakeup
<b>BACD</b>	Automatic Call Distribution-Base
<b>BARS</b>	Basic Automatic Route Selection
<b>BAUT</b>	Basic Authorixation Code
<b>BCSOB</b>	SL- 1 Output Buffer
<b>BGD</b>	Background Terminal Facility
<b>BQUE</b>	Basic Queuing
<b>BRTE</b>	Basic Routing
<b>CAB</b>	Charge/Authorization Base Package
<b>CAS</b>	Centralized Attendant Service



---



<b>CASM</b>	CAS Main
<b>CASR</b>	CAS Remote
<b>CCBQ</b>	Coordinated Call Back Queuing
<b>CCBQCM</b>	Coordinated Call Back Queuing to Conventional Mains
<b>CDP</b>	Coordinated Dialing Plan
<b>CDR</b>	Call Detail Recording
<b>CDRE</b>	CDR Expansion
<b>CDRQ</b>	Emergency <b>Acces</b> Enhancement (911 Option)
<b>CFCT</b>	Call Forward by Call Type
<b>CFNA2</b>	Call <b>Fortward</b> No Answer - Second Level
<b>CHG</b>	CDR with Charge Account
<b>CLNK</b>	CDR with Magnetic Tape
<b>CMAC</b>	ESN Communication Management Center
<b>CPND</b>	Call Party Name Display

<b>CPRK</b>	Call Park
<b>CTY</b>	<b>CDR TTY</b>
<b>CUST</b>	Multi-Customer
<b>DDSP</b>	Digit Display SL- 1 Set
<b>DHLD</b>	Deluxe Hold
<b>DI</b>	Dial Intercom
<b>DISA</b>	Direct System Inward Access
<b>DLDN</b>	Departmental LDN
<b>DND</b>	Do Not Disturb
<b>DNDG</b>	DND Group
<b>DNDI</b>	DND Individual
<b>DNIS</b>	Dial Number Identification Service
<b>DNXP</b>	Directory Number Expansion
<b>DRNG</b>	Distinctive Ringing

<b>DSET</b>	Digital Set <b>M2000</b>
<b>DTI</b>	Digital Trunk Interface
<b>EES</b>	END-to-End Signaling
<b>EOVF</b>	<b>EW</b> nhanced Overflow ( <b>NACD</b> )
<b>FCA</b>	Forced Charge Account
<b>FCBQ</b>	Flexible Call Back Queuing
<b>FTC</b>	Flexible Tone and Digit Switch Control
<b>GRP</b>	<b>Groupe</b> Call
<b>HIST</b>	History File
<b>HOT</b>	Hot <b>L</b> ine Services Enhanced Hot Line Flexible Hot <b>L</b> ine
<b>IAP3P</b>	Integrated Services Digital Network Application Protocol
<b>ICDR</b>	Internal CDR Records
<b>IDC</b>	Incoming DID Digit Conversion
<b>IMS</b>	Integrated Messaging System

**INTR**

Intercept

**ISA**

Integrated Services Access  
Integrated Services Digital Network

**ISDN**

**Integrated** Services Digital Network

**ISL**

Integrated Services Digital Network Signaling Link

**IVMS**

Integrated Voice Messaging System

**LLC**

Line Load Control

**LMAN**

ACD Load Management

**LNK**

Auxiliary Processor Link

**LSEL**

Line Selection

**MCBQ**

Network Queuing - Main

**MCT**

Malicious Call Trace

**MOD**

Music on Delay

**MOH**

Music on Hold

**MR**

Message Registration

---

<b>MSB</b>	Make Set Busy
<b>MUS</b>	Music on Hold
<b>MWC</b>	Message Center
<b>NARS</b>	Network Automatic Route Selection
<b>NAUT</b>	Network Authorization Code
<b>NCOS</b>	Network Class of Service
<b>NFCR</b>	New Flexible Code Restriction
<b>NSC</b>	Network Speed Calling
<b>NSIG</b>	Network Signaling
<b>NTRF</b>	Network Traffic
<b>NTWK</b>	Network Ring Again
<b>NXFER</b>	Network Transfer
<b>o c c</b>	Other Common Carriers
<b>ODAS</b>	Office Data Administration System



<b>OHQ</b>	Off Hook Queuing
<b>OPAO</b>	Out-pulsing of Asterisk and Octothorpe
<b>OPTF</b>	Advanced Features
<b>PBXI</b>	PBX Interface/Digital Trunk Interface
<b>PBXOB</b>	Non SL-1 Output Buffer
<b>PMSI</b>	Property Management system Interface
<b>PQUE</b>	Priority Queuing
<b>PRA</b>	Primary Rate Access
<b>RAN</b>	Recorded Announcement
<b>RESDB</b>	Resident Debug
<b>RMS</b>	Room Status Service
<b>ROA</b>	Recorded Attendant Overflow Announcement
<b>RPE</b>	Remote Peripheral Equipment (1.5 Mb/s)
<b>SCC</b>	Special Common Carrier

---

<b>SCI</b>	Station Category Indication
<b>SLP</b>	Station Loop Preemption
<b>SNR</b>	Stored Number Redial
<b>SR</b>	Set Relocation
<b>SSC</b>	System Speed Call
<b>SS5</b>	500 Set Access to 2500 Set Features
<b>SS25</b>	2500 Set Features
<b>TAD</b>	Time and Date
<b>TDET</b>	Tone Detector
<b>TENS</b>	Multi Tenant Services
<b>TOF</b>	Time Overflow Queuing
<b>TSET</b>	Digital Set <b>M3000</b> (Touchphone)
<b>UMG</b>	User-to-User Teleset Messaging
<b>UST</b>	User Status





SL-1

# Generic XI 1

Memory calculations

© 1984 Northern Telecom

All rights reserved.

Information subject to change without notice.

Release 1 .0

Standard

December 1989

Printed in U.S.A.



553-3001-152

SL-1

## System options 21, 51, 61, 71

Power engineering  
Standard

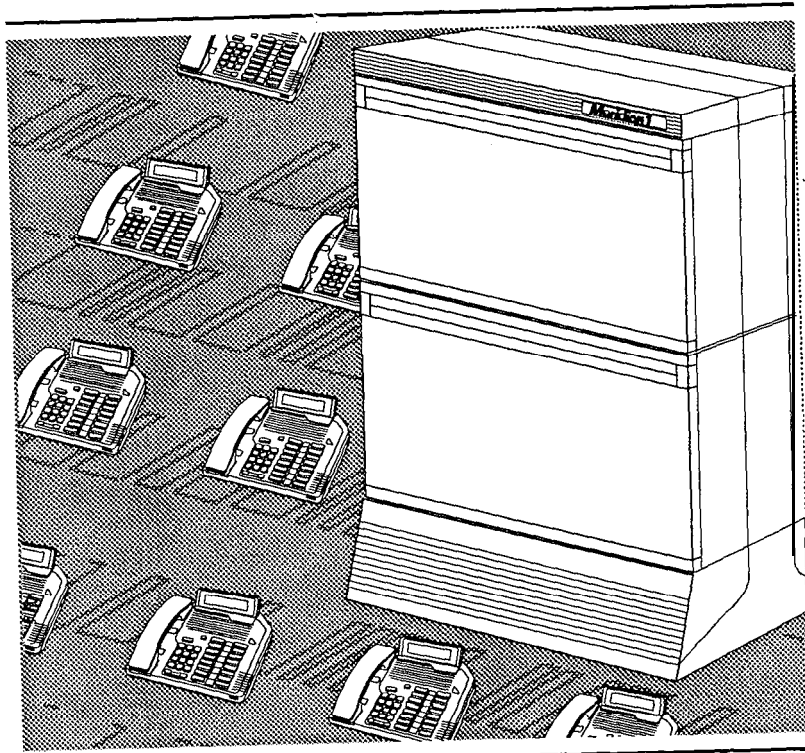

**nt** northern  
telecom

**Meridian 1**  
Communication Systems



---

SL-1

# **System options 21, 51, 61, 71**

Power engineering

---

Publication number: 553-3001-I 52

Document status: Standard

Document release: 1 .0

Date: January 29, 1990

---

© 1990 Northern Telecom

All rights reserved.

---

Power engineering 553-3001-I 52



---

# Revision history

---

**January 29, 1990**

Standard, release 1 .0

---

## About this document

---

This document describes the SL-1 System power and grounding architecture for both AC and DC systems and provides guidelines for calculating system power consumption as well as reserve power requirements.

### References

For information about the power plant used with DC-powered system option 7 1, see the following publications:

- *J2412A—Description, Engineering, Ordering Information, Installation, Connections, Operation and Maintenance* (167-2191-200)
- *NT5C03 Switched Mode Rectifier -48V/50A -Description, Maintenance and Ordering Information PO673491* (169-2031-200)

See the SL-1 planning & engineering guide for

- *Master index* (553-3001-000)
- *System overview* (553-3001-100)
- *Installation planning* (553-3001-120)
- *System engineering* (553-3001-151)
- *Power engineering* (553-3001-152)
- *Spares planning* (553-3001-153)
- *Equipment identification and ordering* (553-3001-W)

See the list of line and trunk circuit descriptions in the *Master index* (553-3001-000) for specific references to lines and trunks.

**See the *SL-I installation and maintenance guide*** for

- ***System installation procedures*** (553-3001-210)
- ***Circuit pack installation and testing*** (553-3001-211)
- ***Installation procedures for telephone sets and attendant consoles*** (553-2201-215)
- ***Extended systems installation*** (553-3001-250)
- ***Disk drive upgrade procedures*** (553-3001-251)
- ***General maintenance information*** (553-3001-500)
- ***Fault clearing*** (553-3001-510)
- ***Hardware replacement*** (553-3001-520)

**See the *SL-I XII software guide*** for an overview of software architecture, procedures for software installation and management, and a detailed description of all XI 1 features and services. This information is **contained** in two documents:

- ***XII software management*** (553-3001-300)
- ***XII features and services*** (553-3001-305)

**See the *SL-I XII input/output guide*** (553-300140) for a description of all administration programs, maintenance programs, and system messages.

---

# Contents

---

<b>SL-1 system power overview</b>	<b>1</b>
General information	1
AC or DC powering	2
<hr/>	
<b>AC power system description</b>	<b>5</b>
Input power specifications	5
Internal power distribution	6
External power distribution and ground connections	11
General notes for AC figures	13
<hr/>	
<b>DC power system description</b>	<b>19</b>
Input power specifications	19
Internal power distribution	20
External power distribution and ground connections	25
General notes for DC figures	25
<hr/>	
<b>System grounding</b>	<b>31</b>
Single Point Ground	32
Additional requirements	33
Isolated ground topology	33
Non-isolated ground topology	34
<hr/>	
<b>Operating power requirements</b>	<b>35</b>
Introduction	35
Circuit pack power consumption	35
Module power consumption	37
System power calculation guidelines	38
Thermal considerations	44

<b>Reserve power</b>	<b>47</b>
AC reserve power	47
DC reserve power	53
<hr/>	
<b>Engineering and configuration guidelines</b>	<b>57</b>
AC power architecture	56
Internal AC power equipment components	56
DC power architecture	61
internal DC power equipment components	62
External DC Power equipment components	63
Commercial power and grounding requirements	66
<hr/>	
<b>Power conductors</b>	<b>69</b>
Wire size calculation guidelines	69
Examples	71
<hr/>	
<b>List of terms</b>	<b>73</b>
<hr/>	

---

# SL-1 system power overview

---

The SL-1 system is an advanced telecommunications system providing state of the art functionality to the customer. The associated power system provides the necessary power for system operation.

## General information

The power system required by the SL- 1 system can be divided into two main categories: external and internal.

The external system consists of the power source and power plant which is located outside of the SL-1 system. This includes the power plant and the reserve power plant, if required, as well as the distribution and grounding components.

The internal system consists of the hardware within the SL-1 system which distributes and converts power. This is made up of a specific power distribution unit (**PDU**), shelf power converters or power supplies as well as distribution cables and grounding hardware. The internal system is chosen to suit the existing or specified external power system and cannot be changed in the field.

There are two basic powering schemes which cause both the internal and the external hardware to change — AC powering and DC powering. The choice of which powering scheme to use is up to the customer and is determined by system cost, reserve power requirements and the type of existing equipment at **the** site. See Installation **planning** (553-3001-120). Figures 1 and 2 show the two basic schemes. Note that both require a source of commercial AC power. In Figure 2, because of the required rectifier, it is referred to as the DC system, which means that the PBX will require a nominal 48 V dc at its input terminals located in the pedestal. The PBX in Figure 1 requires a nominal 208 or 240 V ac at its input terminals located in the pedestal.

In discussing these powering schemes, unless otherwise specified, AC distribution will mean a single phase circuit without a neutral conductor, but with an accompanying green wire ground conductor. The nominal voltage is assumed to be either 208 or 240 volts but any voltage within the range shown in Table 1 is applicable. DC distribution is typically a nominal 48 volts at the input to a UEM power converter under load.



## AC or DC powering

DC powering and AC powering differ primarily in the use of rectifiers. DC systems always require the use of rectifiers (see Figure 2). This is a cost disadvantage for DC in applications that do not require “backup” in the event of a utility power failure. The reason for this is due to the double conversion that is required: line voltage to -48 V dc and then 48 V dc to the required circuit voltages. AC powering, on the other hand, requires only a single conversion — line voltage to the required circuit voltages.

**The** use of a rectifier in DC powering does however become a cost advantage in applications **that** require battery backup. The reason for this cost advantage is that an AC Uninterruptible Power System (UPS) consists of not only a rectifier but also requires the additional cost of an inverter. Both AC and DC require similar battery banks so there will not be much of a cost advantage or disadvantage with these battery plants.

The actual distribution of DC and AC power is similar. DC power will **be** brought into the Pedestal and distributed to the Modules in a similar way to AC power, the difference being that AC uses AC-to-DC Power Supplies rather **than** DC-to-DC Converters.

*Note:* The DC system requires the use of additional input wires in order to handle the lower voltage and its associated higher current.



**Figure 1**  
AC powered system

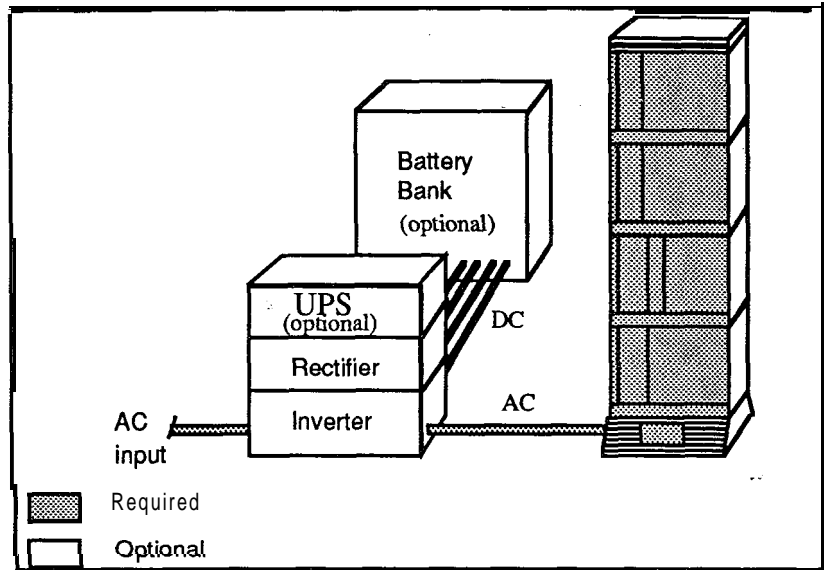

**Figure 2**  
DC powered system

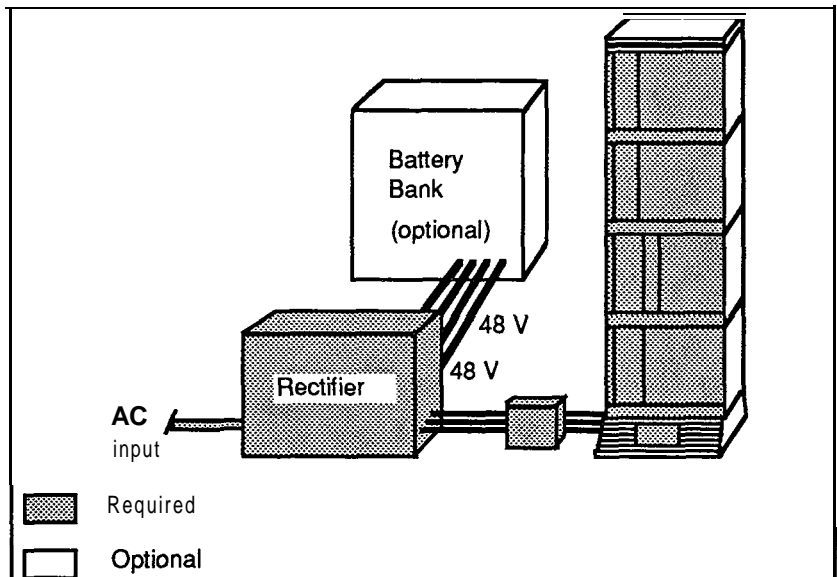





---

## AC power system description

---

This section describes the characteristics of the Meridian SL-1 system where equipment columns are **directly** powered by commercial power.

The commercial power voltage is brought directly into the Pedestal Power Distribution Unit. From there it is passed through separate wiring to the individual modules in order to provide power to the module power supplies.

### Input power specifications

AC power supplies operate at a nominal 208/240 V. A typical system operating from 208 V using four **UEMs will** draw 15-24 Amps, depending on the configuration. These are fed from a central point in the pedestal, access to these connections is provided and should be used to confirm that the line voltage is within the required range as indicated in Tables 1 and 2.

**Table 1**  
**AC input specifications**

Input	Minimum	Nominal	Maximum
Voltage (V ac) at pedestal	180	208/240	250
Frequency (Hz)	47	<b>50/60</b>	63
Current to a pedestal	—	see note	24A
Note: Current is dependent on equipment installed see "Operating power calculation guidelines."			

**Table 2**  
**Transient tolerance**

Transient tolerance (See note)	Amplitude	Duration
Surges	288 U ac	8.34 mS to 50 ms
	276 U ac	50 mS to 500 ms
Sags	146Uac	8.34 mS to 50 ms
	166Uac	50 mS to 500 ms
Spikes	815 Upk	<4.17 ms
	815 U pk to 408 U pk	4.17 to 8.3 ms
Notches	to ou	<4.17 mS
	0 V to 206 V	4.17 mS to 8.3 ms

Note: All transients are applied at the peak of the AC waveform.

## Internal power distribution

Figure 3 shows the internal AC power distribution elements:

- Pedestal Power Distribution Unit (PDU)
- Module to Module Harness
- Module Power Distribution Unit (MPDU)
- Module to Backplane Harness
- AC Power Supplies

The power cables enter the Pedestal and connect to the Field Wiring Terminal Block which is located in the Power Distribution Unit (PDU). From that terminal block, the AC voltage passes into the Power Distribution Unit (PDU) which has a single circuit breaker providing power to each of the four modules and the cooling fans. The System monitor runs off a small AC Power Supply which operates independent of the circuit breaker. Module to Module distribution produces individual AC power to each module.

Figure 3  
AC internal power distribution

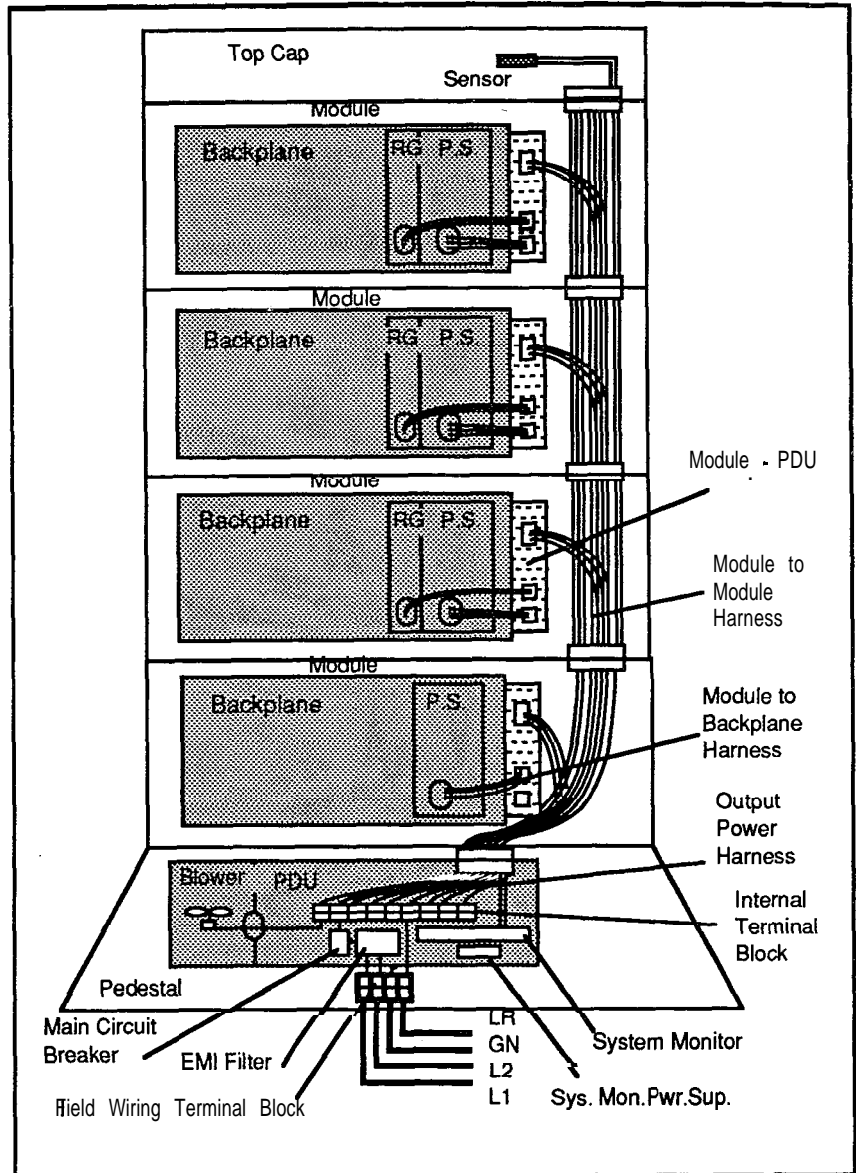

## **Pedestal Power Distribution Unit (PDU)**

The Pedestal PDU provides the following:

- The Field Wiring Terminal Block provides a connection point for the external wiring that is brought into the Pedestal.
- The EM1 Filter provides filtering of the wires connecting back to the Utility in order to meet FCC and DOC requirements.
- The Main Circuit Breaker provides both a single protection device for overload currents and a single trip device to shut down the column in the event of a thermal overload.
- The Internal Terminal Block provides individual power hand-off points so that each Module is independently powered from the Pedestal in order to minimize wire size.
- The Power/Signal Harness provides the Power and Signal interconnections in the Pedestal for the Blower Unit and System Monitor.
- The System Monitor Power Supply (a small **+5V** power supply) provides power to the System Monitor, even when the main circuit breaker has **tripped**.
- The Output Power Harness provides the independent power connections from the Pedestal to the Module above it.

## **Module to Module Harness**

The Module to Module Harness provides the following:

- The Module Feed provides the independent power feed(s) to the Module above itself.
- The Module PDU Feed provides the power feed to the Module PDU.

## **Module Power Distribution Unit (MPDU)**

The Module PDU provides the following functions:

- The Circuit Breaker provides a Module level of current protection so that a fault on one Module will be disconnected while the other Modules remain functional.
- The MPDU to Backplane Harness feed provides the power feed to the backplane harness which in turn provides power to the AC Power Supplies through the backplane power connector.

## Module to Backplane Harness

The Module to Backplane Harness provides the power to the AC Power Supplies through the backplane power connector.

## AC Power Supplies

There are three different power supplies that provide power to the Peripheral Equipment, Common Equipment and Common/Peripheral Equipment Modules. In addition, the Ringing Generator provides ringing voltage for the Peripheral Equipment Modules.

At each shelf, the 208/240 V ac is received through the backplane distribution harness and converted to the necessary voltages for the individual module. Circuit breakers are located on each MPDU to provide for safe operation and easy maintenance.

The output voltages and currents of the power supplies are listed in Tables 3 through 6.

Table 3

### Peripheral Equipment Power Supply

NT8D06AA	
output v	Output A
+5.1 v	28 A
+8.5 V	4.0 A
+10 v	0.5 A
-10 v	0.5 A
+15 v	17A
-15 v	15 A
-48V	7.7 A

**Table 4**  
**Common Equipment Power Supply**

<b>NT8D29AA</b>	
output v	output A
+5.1 V	60 A
+12 V	2.5 A
-12 v	1.0 A

**Table 5**  
**Ringling Generator**

<b>NT8021 AA</b>	
Output VNA	Output F
<b>70 V ac/8 VA</b>	<b>25/50 Hz</b>
80 V ac/8 VA	25/50 Hz
<b>86 V ax/8 VA</b>	<b>20/25 Hz</b>
output v	Output A
▪ 150v	0.200 A

**Table 6**  
**Common/Peripheral Equipment Power Supply**

<b>NT7D14AA</b>	
<b>output v</b>	<b>Output A</b>
+5.1 V	60 A
+8.5 V	2.5 A
+12	1.0 A
-12	0.75 A
+15 V	10 A
-15 v	10 A
-48 V	4.75 A
-150 v	0.13 A
<b>output V/VA</b>	<b>Output F</b>
86 V ac / 5 VA	20 Hz

## External power distribution and ground connections

The external distribution for AC powered systems is very simple. No additional equipment is required; simply connect to an AC source of power. One 208 or 240 volt circuit with 30 amps protection (circuit breaker or fuse) should be used to feed each pedestal.

Figure 4 shows the important grounding connections and the use of the ACEG (AC Equipment Ground) or IGB (Insulated Ground Bus). For a general discussion of the grounding philosophy, see the section "System grounding."

Figures 5 through 8 for AC distribution in this section are shown for connection to standard utility power. If an Uninterruptible Power System (UPS) is used, refer to the later section on AC reserve power.



**Figure 4**  
**Grounding and equalizing nodes**

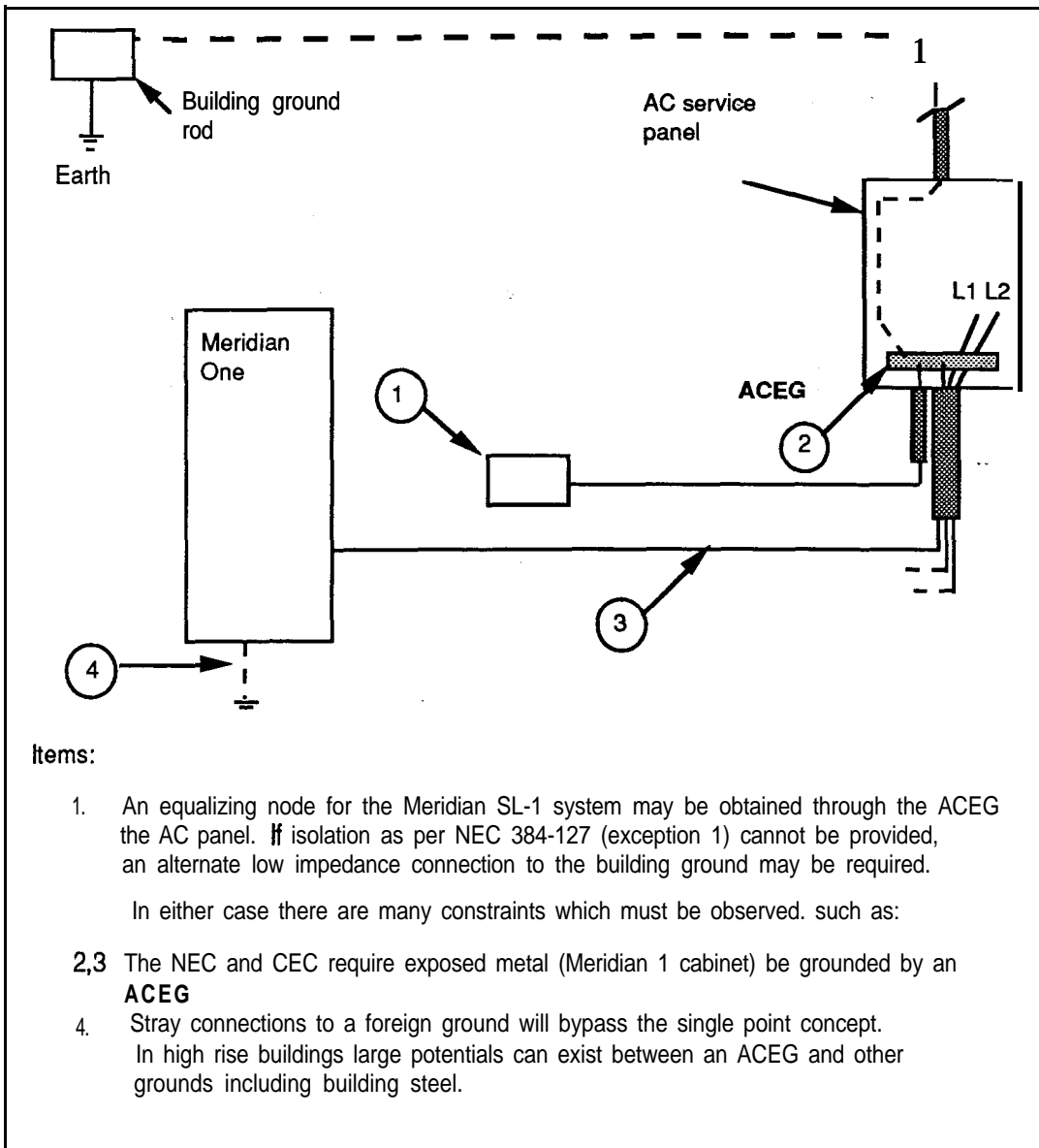

**Items:**

1. An equalizing node for the Meridian SL-1 system may be obtained through the ACEG the AC panel. If isolation as per NEC 384-127 (exception 1) cannot be provided, an alternate low impedance connection to the building ground may be required.  
 In either case there are many constraints which must be observed, such as:
- 2,3 The NEC and CEC require exposed metal (Meridian 1 cabinet) be grounded by an **ACEG**
4. Stray connections to a foreign ground will bypass the single point concept.  
 In high rise buildings large potentials can exist between an ACEG and other grounds including building steel.

## General notes for AC figures

**Permanent connection to Branch Circuit** When conduit or a raceway is used it should be metal and regardless of the type, it must contain an insulated ground wire (green), 6 AWG or larger.

**Cord connection to Branch Circuit** A separate safety ground is always required when removable line cords are used for the following reasons:

- a telephone wire could contact AC elsewhere in the building while the cord is unplugged (during installation)
- to minimize hazards from lightning transients when unplugged
- to minimize the effects of stray grounds (pedestal to floor RS-232 links to monitors) during normal operation

The additional safety ground must be 6 AWG or larger, preferably insulated and must be connected from the pedestal Frame Ground to the Service Panel Ground Bus

One 30 Amp circuit per pedestal is required. Isolation as required by NEC 250-74 and 384-27 (Exception 1) is preferred.

**Single Point Ground (SPG) and Isolated Ground Bus (IGB)** The SPG in this grounding scheme is the Equipment Grounding Terminal Bar in the AC distribution panel (**ACEG**). If this bar is isolated from the distribution panel, as is recommended, then it is referred to as an IGB. In the following figures, the preferred method using an ACEG is illustrated.

**Logic Return (LR) wiring and Logic Return Equalizer (LRE) location** When multiple columns are present or where links will be made to existing SL-1 equipment, the LRs of the different columns must be joined. See **System installation procedures** (553-3001-210). An LRE (a bar or plate) in the immediate vicinity allows the LRs to be joined to a single equalizing point. A 6 AWG conductor then connects the LRE to the IGB in the AC panel.

For these multiple column applications, the LRE is typically located in a nearby rack, overhead trough or under a raised floor. It must be insulated from its support structure.

Note: This single point equalizing is **required** because communication between modules that are not in the same physical line-up would put small amounts of DC on the AC (green wire) ground. Likewise residual AC voltages would be superimposed (longitudinally) on the logic. There is only a few volts of common mode rejection capability on these lines. Refer also to the System Grounding section later in this document.

120 V receptacles and cord or conduit items in **the** figures are used only as required.

### Single column AC powered system

A single column system can be easily powered as shown in Figure 5.

**Figure 5**  
Single-column distribution

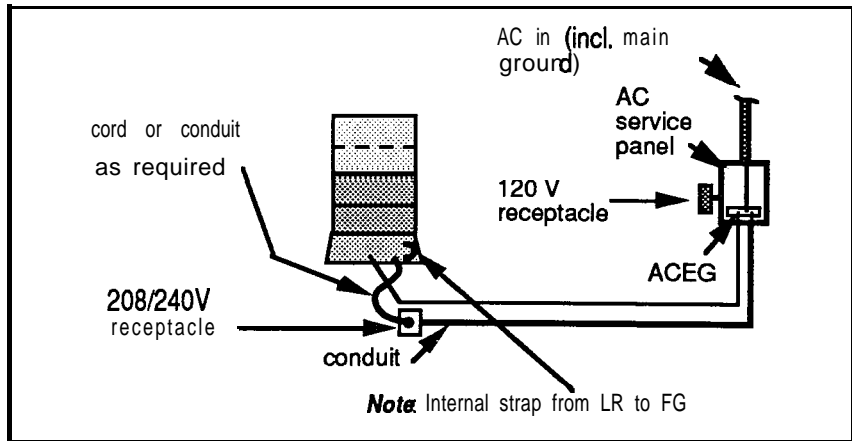

## Multi-column AC powered system

A multi-column system (with one or more columns physically adjacent to each other) can be powered as shown in Figure 6.

**Figure 6**  
Multi-column distribution

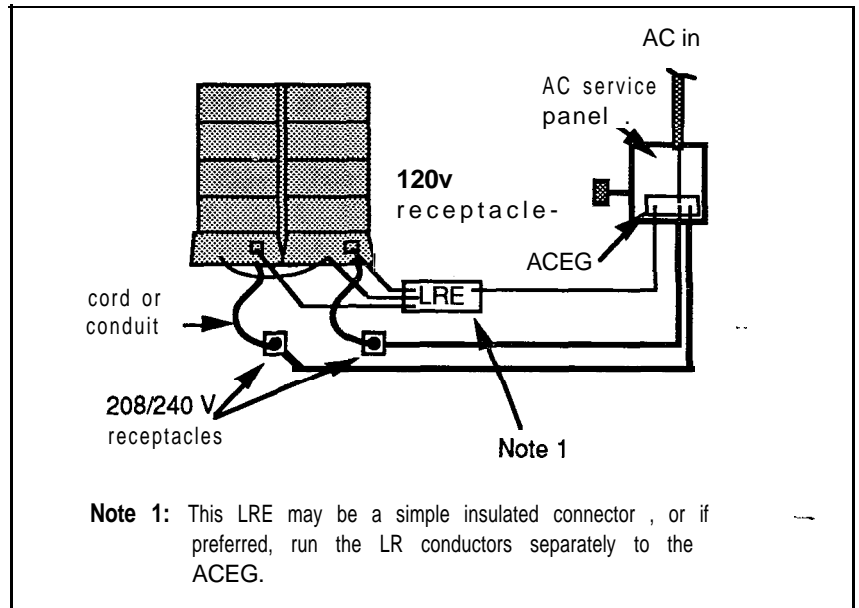

### Multi-row AC powered system

A multi-row system (with several rows of one or more columns physically adjacent to each other) can be powered as shown in Figure 7.

Figure 7  
Multi-row distribution

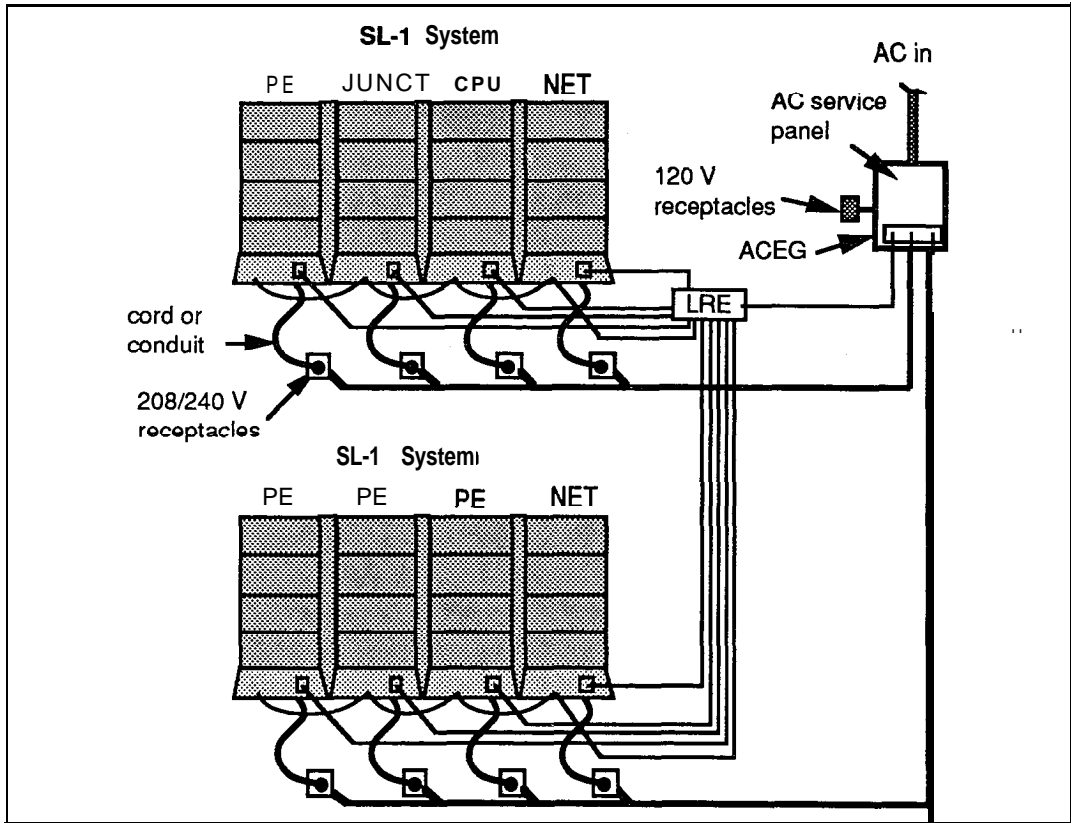

## Extended systems

A typical large extended system with both new and existing equipment is shown in Figure 8.

Figure 8  
External distribution for AC systems

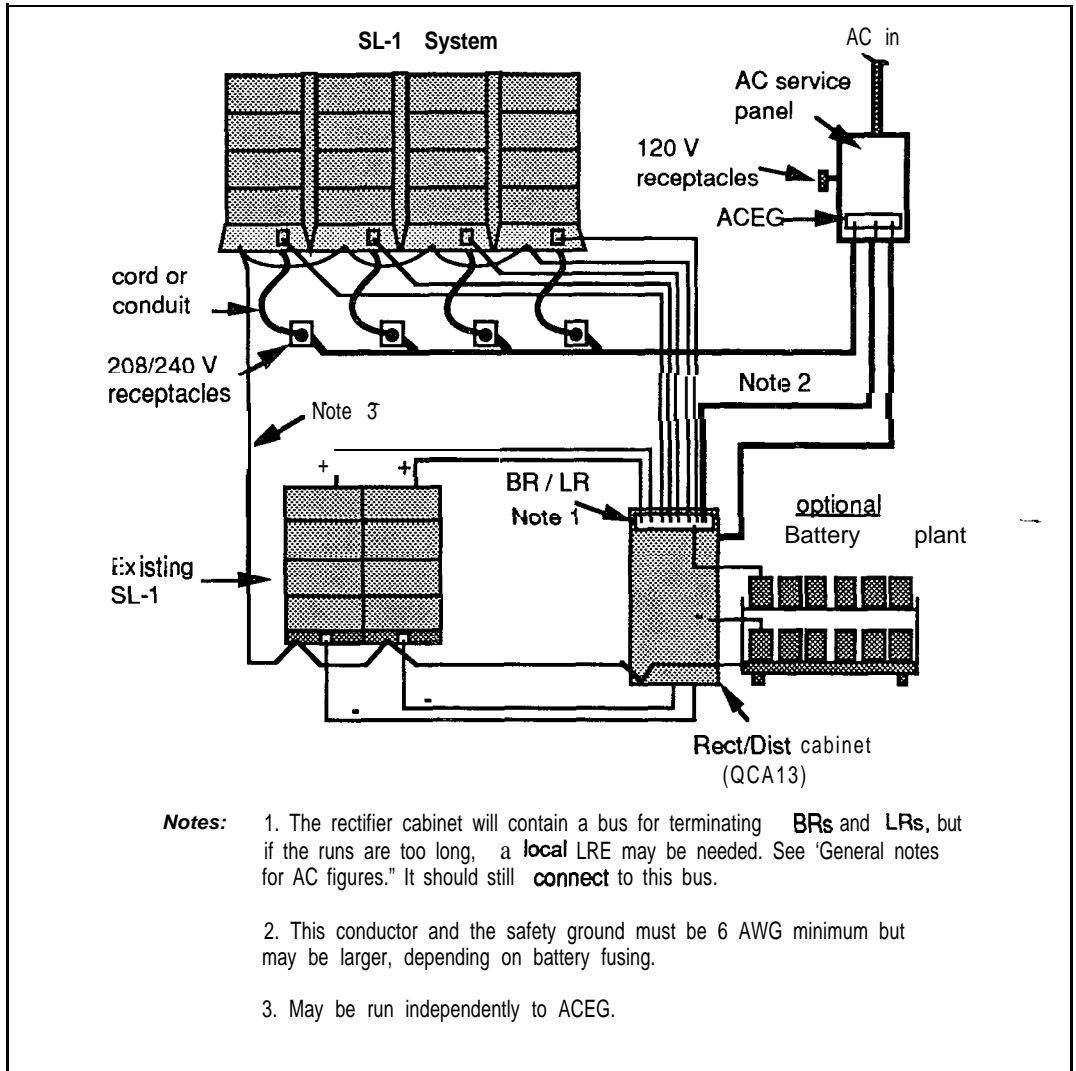



1



---

## DC power system description

---

This section outlines the characteristics and requirements for the DC auxiliary power that the system is connected to.

### Input power specifications

The DC supply chosen must **accept** the calculated current drain and operate within the following specifications:

**Table 7**  
**input specifications**

<b>Input</b>	<b>Pedestal</b>	<b>Battery</b>
Maximum range	-40.0 to -56.5	-42 to -56.5
Expected nominal (with 24 stationary cells)	—	-52.08
Expected nominal (with 23 sealed cells)	—	-51.75
Expected nominal (with 24 sealed cells)	—	-54.00
Noise (max C msg)	—	32 dBrnC



## Internal power distribution

Figure 9 shows the internal DC power distribution elements:

- Pedestal Power Distribution Unit (**PDU**)
- Module to Module Harness
- Module to Backplane Harness
- DC Power Converters

The power cables enter the Pedestal and connect to an internal terminal block located in the pedestal. From there, the DC voltage enters the Power Distribution Unit (**PDU**) which has five circuit breakers, one for each of the four modules and one for the cooling fans. The System monitor runs off a DC-to-DC converter. Module to Module distribution brings individual DC power to each module similar to AC distribution.

### Pedestal Power Distribution Unit (PDU)

The Pedestal PDU provides the following:

- The Field Wiring Terminal **Block** provides a connection point in the bottom of the Pedestal for the external wiring.
- The Circuit Breakers provide individual Module protection devices for Module overload currents and a single trip function to shut down the Stack in the event of a thermal overload.
- The Internal Terminal Block provides individual power hand-off points so that each Module is independently powered from the Pedestal in order to minimize wire size.
- The Power/Signal Harness provides the Power and Signal connections in the PDU for the Blower Unit and System Monitor.
- The System Monitor Power Supply (a small **+5V** DC-DC Converter) provides power to the System Monitor, even when all of the Circuit Breakers have been tripped.
- The Output Power Harness provides the independent power connections from the Pedestal to the Module above it.

Figure 9  
DC internal power distribution

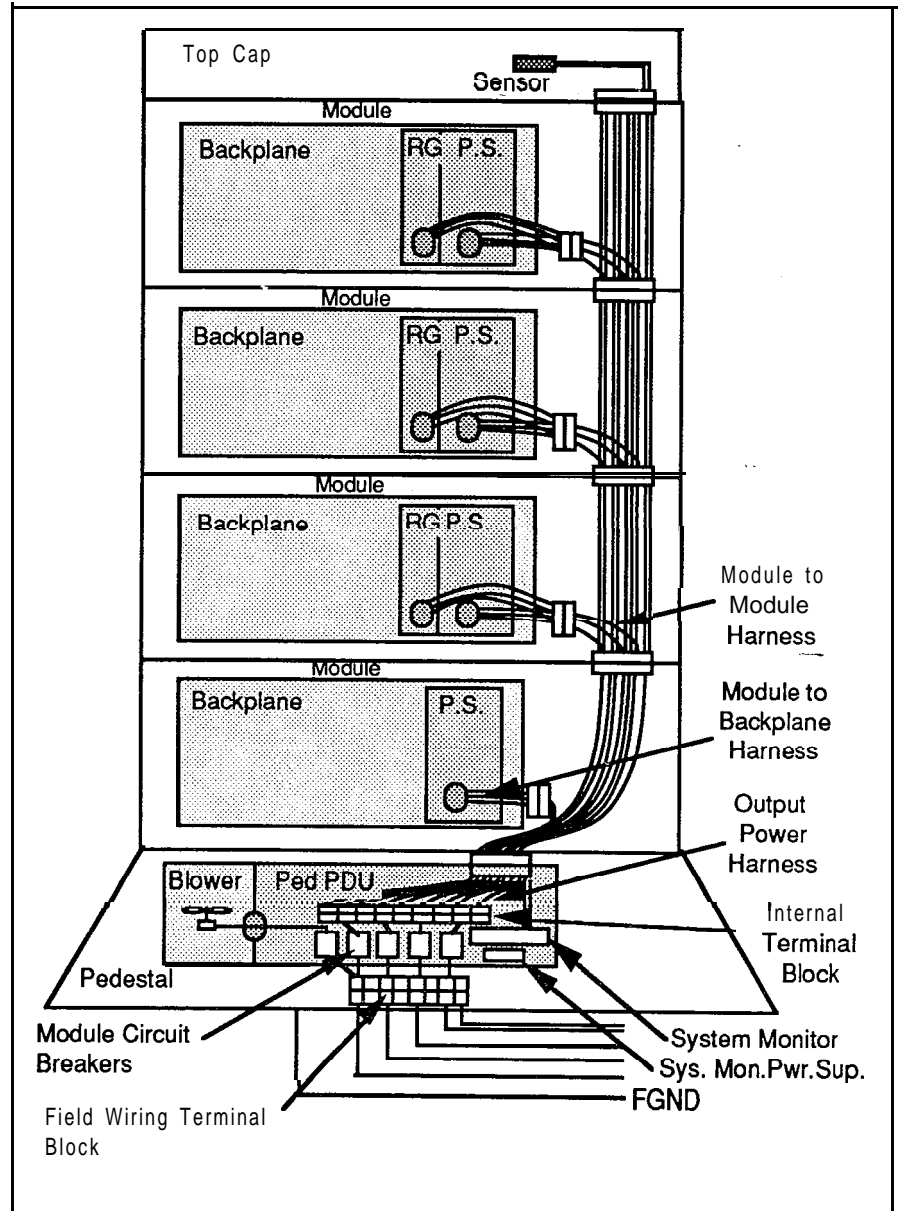

### **Module to Module Harness**

The Module to Module Harness provides the following:

- The Module Feed provides the independent power feed to the Modules above itself.
- The Module Harness Feed provides the power feed to the Module backplane Harness.

### **Module to Backplane Harness**

The Module to Backplane Harness provides the power feed to the backplane connector which in turn provides power to the DC Power Converters.

### **DC Power Converters**

Three different DC Power Converters provide power to the Peripheral Equipment, Common Equipment and Common/Peripheral Equipment Modules. The Ringing Generator provides ringing voltage for Peripheral Equipment Modules.

At each shelf, -48 V is received through the backplane distribution harness and converted to the necessary voltages for the individual module. Switches are located on each converter to provide for safe operation and easy maintenance. With separate Module breakers located in the Pedestal PDU, the Module Power Distribution Unit (**MPDU**) is not necessary.



The output voltages and currents of the power converters are listed in Tables 8 through 11.

**Table 8**  
Peripheral Equipment Converter

<b>NT6D40AA</b>	
<b>Output v</b>	<b>Output A</b>
+5.1 v	28A
+8.5 V	4.0 A
+10 v	0.5 A
-10 v	0.5 A
+15 v	<b>17 A</b>
-15 v	<b>15 A</b>
-48v	7.7 A

**Table 9**  
Common Equipment Converter

<b>NT6D41 AA</b>	
<b>output v</b>	<b>Output A</b>
+5.1 v	60 A
+12 v	3.5 A
-12v	<b>1.0 A</b>

**Table 10**  
**Ringling Generator**

<b>NT7D03AA</b>	
<b>Output VNA</b>	<b>Output. F</b>
70 V ac/16 VA	20/25/50 Hz
80 V ac/16 VA	20/25/50 Hz
86 V ac/16 VA	20/25/50 Hz
<b>output v</b>	<b>output A</b>
-150 v	0.200 A

**Table 11**  
**Common/Peripheral Equipment Converter**

<b>NT7D04AA</b>	
<b>output v</b>	<b>output A</b>
+5.1 v	5 a A
+8.5 V	2.5 A
+12	1.0 A
-12	0.75 A
+15 v	10 A
-15 v	10 A
-48V	4.75 A
-150 v	0.2 A
<b>Output VIVA</b>	<b>Output F</b>
70 V ac/16 VA	20/25/50 Hz
80 V ac/16 VA	20/25/50 Hz
86 V ac/16 VA	20/25/50 Hz

## External power distribution and ground connections

The power plants shown in the following figures are typical but there are many variations possible for the item labeled "Rect/Dist." It could be existing customer equipment or a system that Northern Telecom either supplies or recommends. In any case, the rectifier and **distribution** equipment are required; the batteries are optional.

**Note:** The **NT6D52** Switched Mode Rectifier is a QRF12 mounted within an **EMI** enclosure.

In all cases it will be necessary to carefully plan ahead. Refer to the chapter entitled "Engineering and configuration guidelines."

Figures 10 through 13 also show the important grounding connections and the use of the IGB (Insulated Ground Bus). For a general discussion of the grounding philosophy, see "System grounding."

### General notes for DC figures

**Permanent Connection of the rectifier(s) to Branch Circuit** When conduit or a raceway is used it should be metal and regardless of **the type**, it must contain an insulated ground wire (green), 6 AWG or larger.

**Cord Connection of the rectifier(s) to Branch Circuit** A separate **safety-ground** is **always** required when removable line cords are used for the following reasons:

- a telephone wire could contact AC elsewhere in the building while the cord is unplugged (during installation)
- to minimize hazards from lightning transients when unplugged
- to minimize the effects of stray grounds (pedestal to floor RS-232 links to monitors) during normal operation

This additional safety ground must be 6 AWG or larger, preferably insulated and must be connected from the pedestal Frame Ground to the Logic Return Equalizer (with Northern Telecom power units). With customer provided power, the safety ground must go directly to the ACEG. See Figure 12.

It is preferred that the outlets for rectifier powering be isolated according to **NEC 250-74** and 384-27 (Exception 1).

**Single Point Ground (SPG) and Isolated Ground Bus (IGB)** The SPG in this grounding scheme is the AC Equipment Grounding bar in the AC distribution panel (ACEG). If this bar is insulated from the distribution panel, as is recommended, then it is referred to as an IGB. In the following figures, the preferred methods for using an ACEG and an IGB are illustrated.

**Logic Return (LR) wiring and Logic Return Equalizer (LRE) location**

When multiple columns are present or where links will be made to existing SL-1 equipment, the LRs of the different columns must be joined. Refer to **System installation procedures** (553-3001-210). When using a Distribution Unit such as the QBL15, QCA13 and most others, the existing Battery Return (BR) bus will serve double duty as the LRE. The logic return wire must be run in conduit to the LRE. A 6 AWG conductor then connects the BR (LRE) to the ACEG in the AC panel.

This single point equalizing is required because communication between modules that are not in the same physical line-up would put small amounts of DC on the AC (green wire) ground. Residual AC voltages would be superimposed (longitudinally) on the logic. There are only a few volts of common mode rejection capability on these lines. Refer to "System grounding."

120 V receptacles and cord or conduit items in the figures are used as required.

**Junction Box** A junction box close to the pedestal may be required depending on the wire size required between the pedestal and the distribution point. See the chapter entitled "Power conductors."

**Figure 10**  
**Multi-column distribution with NT6D52 and QBL15**

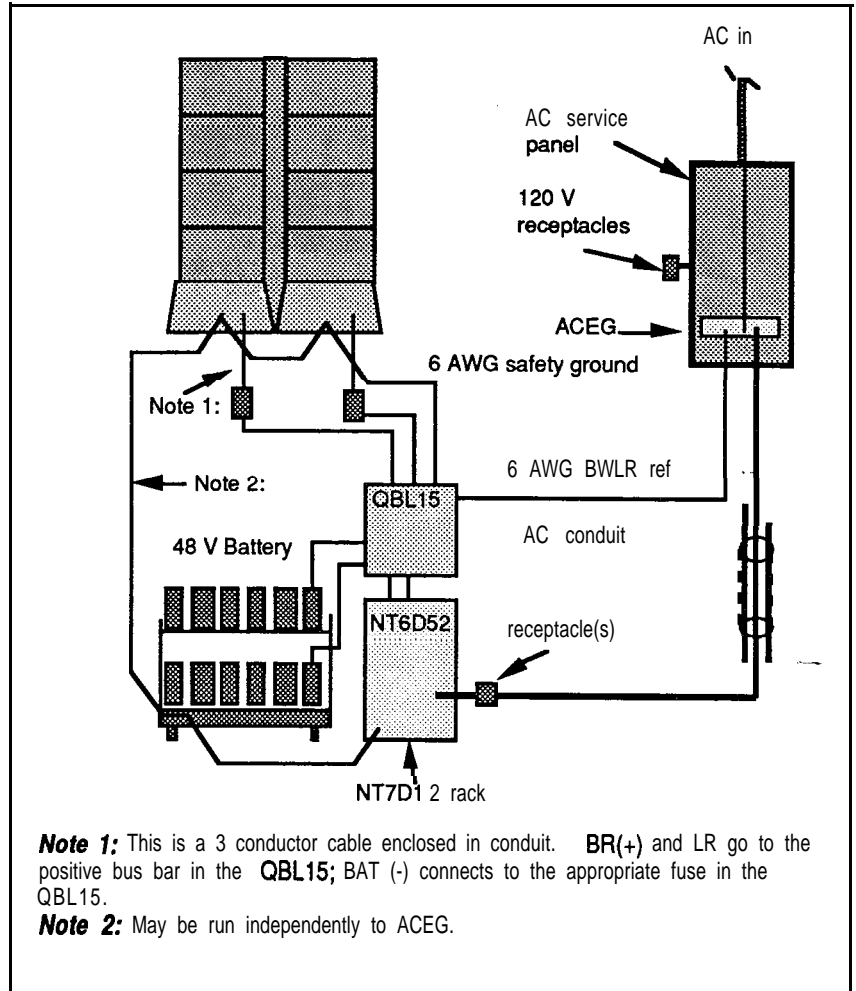
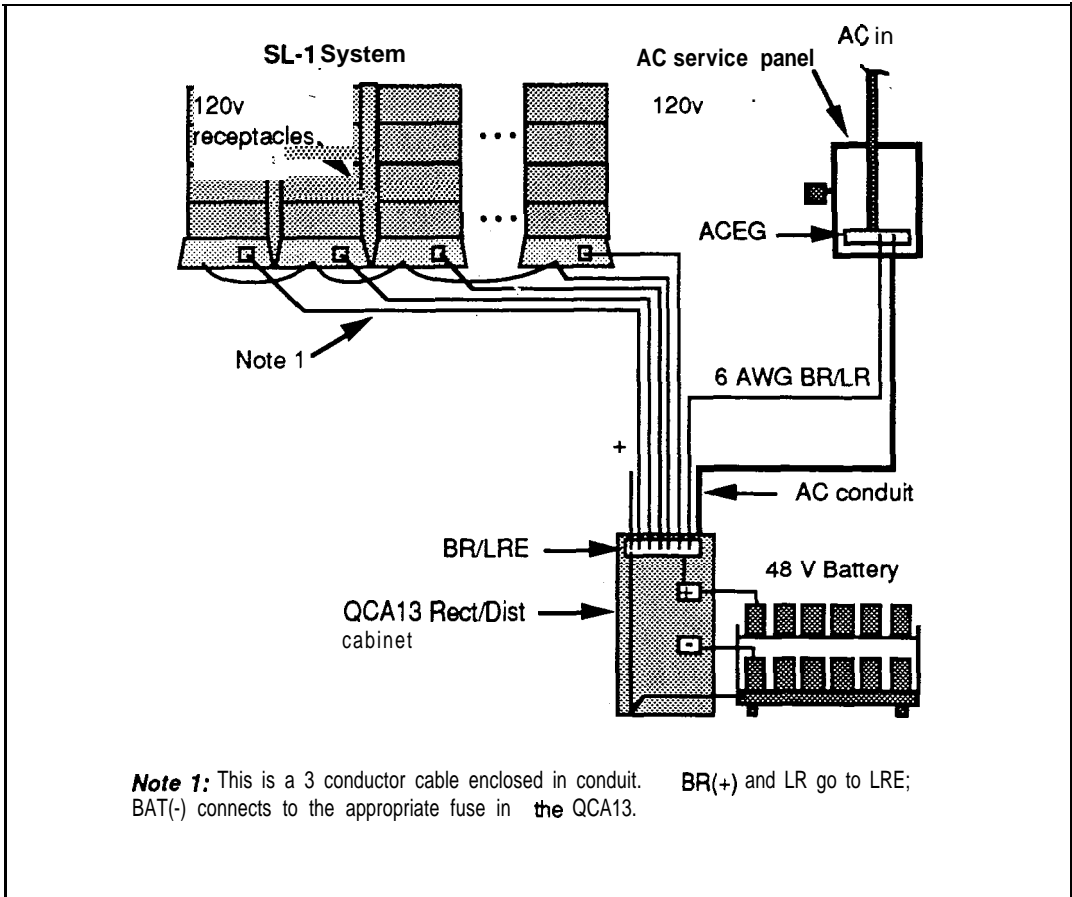
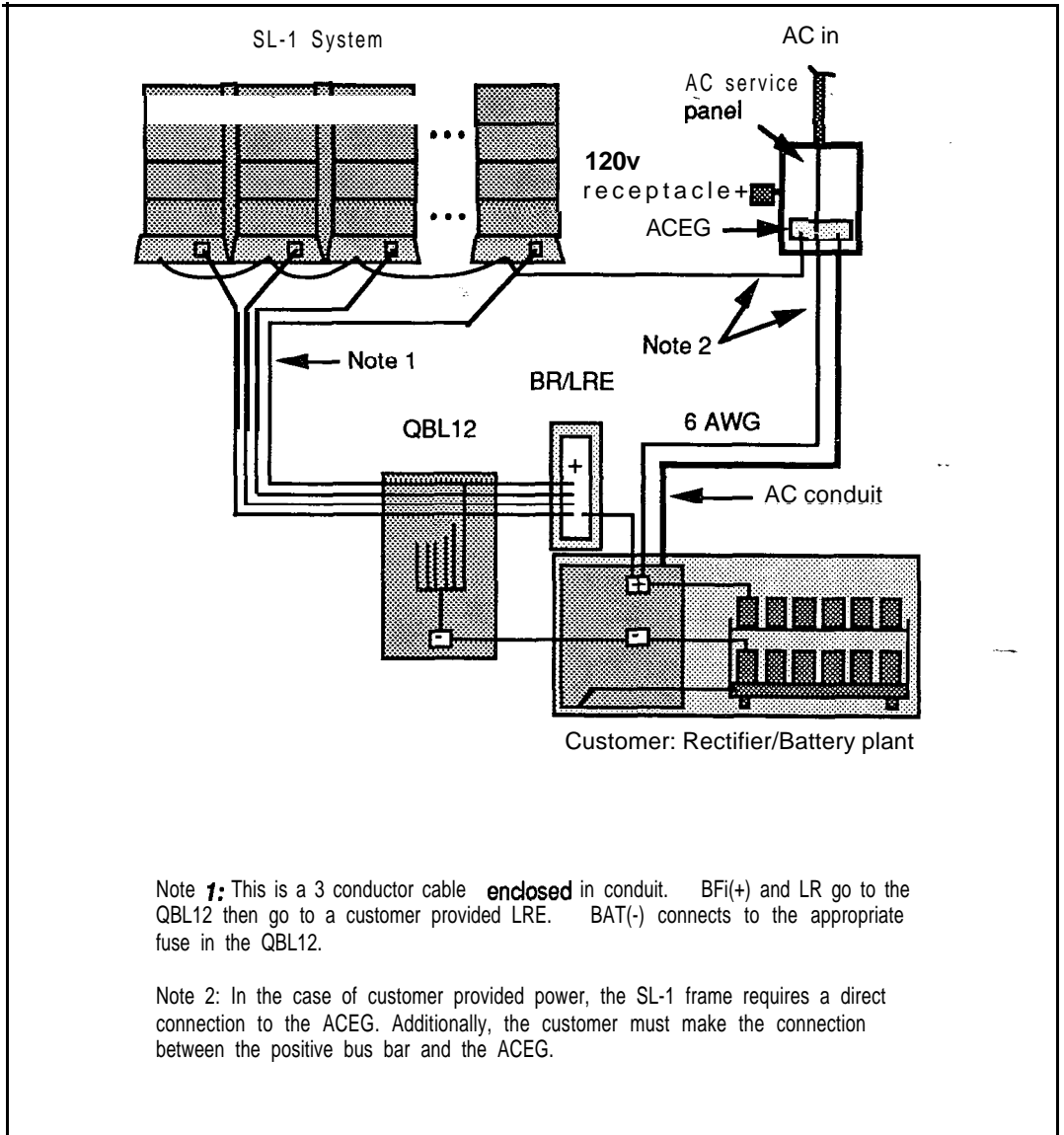



Figure 11  
Multi-column distribution with QCA13



**Figure 12**  
Multi-column distribution with **QBL12** customer power



**Figure 13**  
Extended systems

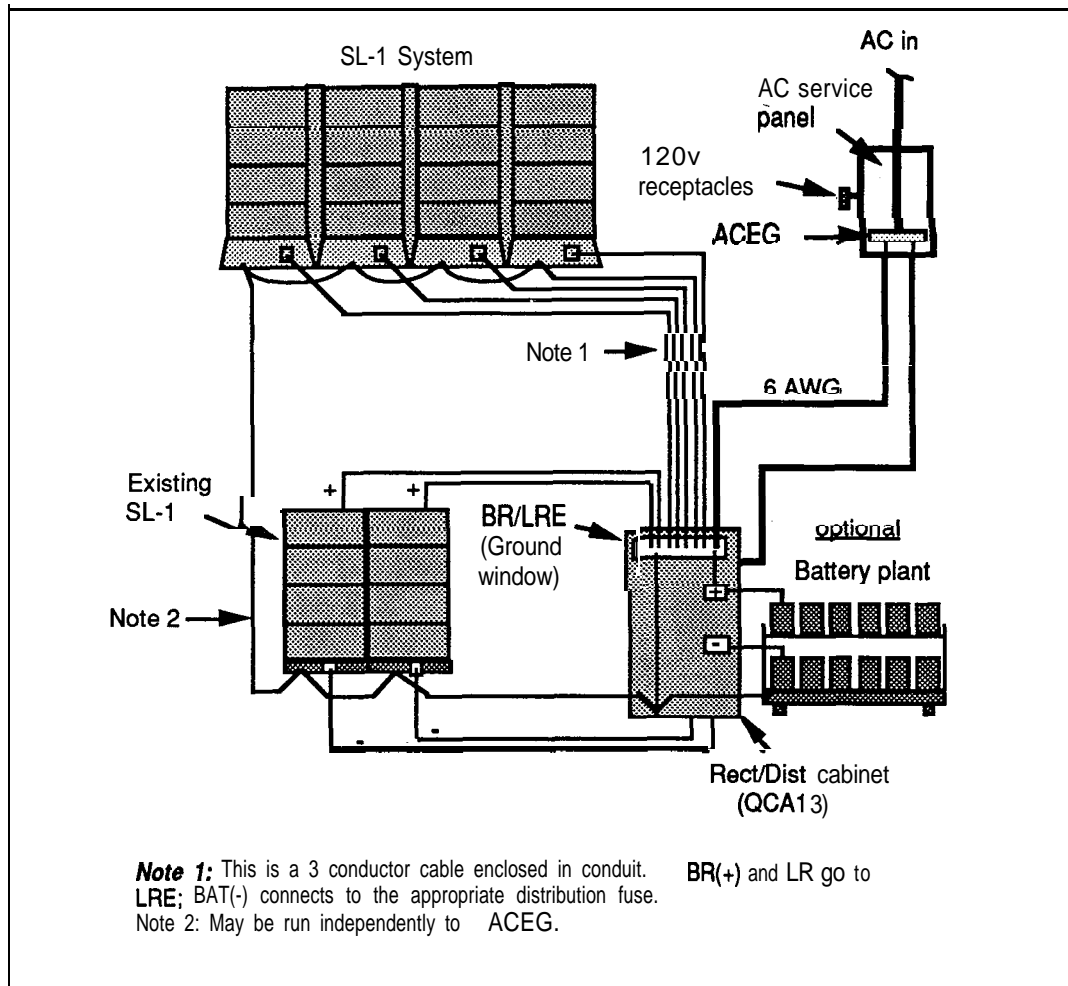

---

## System grounding

---

Proper grounding is essential to system operation. The SL-1 system requires a single-point ground. Proper grounding is required for trouble-free operation and for the safety of personnel. The DC resistance of the conductor joining the SL-1 system system ground reference to the main building ground should be as close to zero as possible. The maximum total resistance from an SL-1 System pedestal to the main building ground cannot exceed 0.5 ohms, The external earth ground should meet **NEC/CEC** requirements.

Lack of proper grounding can result in an installation that is not protected from lightning or power related faults and does not provide an optimum path for residual AC or DC currents. This may cause:

- Hazards for personnel working on or using the equipment
- Various service interruptions
- Excess noise on analog circuits
- High bit error rate on digital circuits

**Note:** All voice and data lines leaving or entering the SL- 1 system which mn external to the building must have fault protectors that connect directly to earth ground. This is not the ground being discussed here.

## Single Point Ground

This system does not, by design, require an isolated AC ground (**IG**) system (although local codes may require it). The system **does** require a single point ground (SPG) system. The SPG is needed because several conductors are used as returns. These include battery returns (**BR**) and logic returns (**LR**). Logic return is the name used to bring this particular return out of the pedestal. But, internally, several other internal ground returns (also called analog ground or talk battery return) are connected to the LR.

In its simplest form, the SPG may be the Isolated Ground (**IG**) bus or AC Equipment Ground (ACEG) bus in the AC panel. This can be implemented if:

- The electrical code allows isolated grounds (as per **NEC 384-27** exception 1. in the USA).
- **This** ground bar located in the AC panel has sufficient terminal points.
- There is no non isolated communication links to existing PBX or other communication equipment.

Using an Isolated Ground bus is often a lower cost method but is not allowed by all telcos and may be prohibited by local ordinances. An alternate ground will be needed where an AC panel with an IG bus cannot be provided. When an alternate SPG is used or where there are too many return conductors to terminate on an IG bus in the AC panel, one or more ground collector nodes -- may be required. A grouping of like returns, prior to attaching to the SPG window is preferred to many long runs of smaller diameter cable. See "List of terms" for an explanation of these ground nodes.

**LRE** A Logic Return Equalizing bus (copper plate or bar) is needed on **multi-**column systems where the IG bus in the AC panel is:

- not being used because of local electrical code requirements
- too far removed from the pedestals being served
- too small (insufficient connection points)
- not expected to be the best ground available (for example, it is known to be noisy or there is a more direct ground connection)

When the LRE function is served by something like an ACIG bus or the **LRE** bus is also used to terminate system returns other than logic returns, there can be confusion over terms. In general, large spread out systems require a **star-**

like ground system with local ground references like the LRE and ACIG coming together at a main ground window, while small systems tend to use a ground bar or plate for several purposes and it ends up taking on the name of its primary function.

## Additional requirements

The following must also be observed to implement the single-point ground concept:

- All ground conductors must be identified in accordance with local codes and terminated in a manner that is permanent, resulting in low impedance connections.
- Terminations should be accessible for inspection and maintenance during the life of the installation.
- All grounding conductors must be continuous with no splices or junctions and tagged, **“DO not remove or disconnect.”** They should also be insulated against contact with foreign grounds.
- Grounding conductors must be no-load, noncurrent carrying cables under normal operating conditions.
- The use of building steel as part of the ground system (in the series path) is not recommended. However, in a steel-framed building, the SL- 1 System main ground interface must be referenced to structural steel (either on the same floor or within one floor) in order to minimize lightning hazards.

## Isolated ground topology

A dedicated Isolated Ground (IG) bus bar is required with this method. This IG bus is located in the ac panel and serves as the ground window. It is used for all AC (green wire) grounds as well as logic returns. It also accommodates a conductor which references to the (+) battery bus in a DC system. An alternate form of this isolated topology is to use one or more isolated equalizing bars external to the AC panel but which connect to ground exclusively through the AC IG bus.

Isolated orange outlets are required (as per **NEC 250-74** exception 4). Grounding conductors shall be routed with the phase conductors (Article 300-20). All ground wiring for IG receptacles are to be terminated on the dedicated IG bus according to applicable codes (complies with NEC 384-27).

## Non-isolated ground topology

In a non isolated system the AC equipment ground (ACEG) connects to the metal panel, and the associated conduit may also contact various structural metal. This ground alone is not adequate for the SL-1 system. A true SPG system will not be possible, but a dedicated ground conductor which connects to the main building ground is then used for the main ground window to terminate logic returns and reference the (+) battery bus. Frame grounds will connect to the ACEG.

---

# Operating power requirements

---

## Introduction

This section contains:

- power consumption data for both circuit packs and full modules
- guidelines and methods to help you determine total system power requirements, for both AC and DC systems

## Circuit pack power consumption

The power consumption of all currently-supported peripheral equipment circuit cards is given in Tables 12 and 13.

All of the power data is stated in Watts for simplicity, with conversion to AC or DC current occurring only at the last step in the calculation. In addition, all of the stated numbers have *already* taken the average efficiency of the Module power converters into account.

The traffic assumptions used in these figures are 25% active (9 CCS) for digital and analog lines, and 100% active (36 CCS) for trunks. Note that the power consumption of digital line cards does not vary greatly with traffic, as it may with analog line cards.



**Table 12**  
**NT8D37 Intelligent peripheral equipment power consumption**

Circuit pack	Typical power (Watts)
NT8D01 AC Controller-4	3 2
NT8D01AD Controller-2	32
NT8D02AA Digital LC	28
NT8D03AA Analog LC	20
NT8D09AA Analog/Msg Waiting LC	20
NT8D14AA Universal Trunk	36
NT8D15AA E&M Trunk	34
NT8D16AA Digitone Receiver	7

**Table 13**  
**NT8D13 Peripheral equipment power consumption**

Circuit pack	Typical power (Watts)
QPC71 F	2.5
QPC192B	12.0
QPC250B	2.5
QPC297	7.1
QPC422A	10.9
QPC430E	14.8
QPC432C	10.2
QPC449D	15.6
QPC450E	7.0
QPC578D	24.6
QPC594D	32.8
QPC659C	40.4
QPC723A	14.8
QPC789A	26.4

## Module power consumption

The typical and worst case power consumption data for each fully configured module are shown in Table 14.

The “typical power” data is generally adequate for use in **system** power engineering calculations, since it is representative of most systems with Modules fully loaded (configured) with cards, and under moderate traffic conditions.

The “maximum power” data is shown for reference and planning purposes when needed, and was calculated for each module based on a fully-loaded card cage, in the worst-possible operational configuration (in terms of power consumption), with each card consuming typical power, plus 10% added margin. For example, the maximum power consumption for the **NT8D37** Intelligent Peripheral Equipment Module was based on a configuration of sixteen **NT8D14AA** Universal Trunk cards, all under 100% traffic conditions, along with a Controller card and additional power margin.

**Table 14**  
**SL-1 System UEM power consumption**

Module	Power consumption (Watts)	
	Typical	Maximum
<b>NT6D39 CPU/Network</b>	<b>400</b>	<b>420</b>
<b>NT6D44 Meridian Mail</b>	<b>400</b>	<b>450</b>
<b>NT8D11 Common/Peripheral Equip.</b>	500	690
<b>NT8D13 Peripheral Equipment</b>	<b>400</b>	<b>575</b>
<b>NT8D34 CPU</b>	<b>300</b>	<b>335</b>
<b>NT8D35 Network</b>	<b>300</b>	<b>325</b>
<b>NT8D36 Junctor</b>	0	0
<b>NT8D37 Peripheral Equipment</b>	<b>550</b>	<b>720</b>
<b>NT8D47 Remote Peripheral Equipment</b>	<b>300</b>	<b>350</b>
Pedestal (Blowers)	<b>50</b>	<b>80</b>

## System power calculation guidelines

The SL- 1 system was designed so that there would be no restrictions as a result of power or thermal limitations. In other words, any card can go in any slot, and all modules can be filled to capacity with any (logically) valid combination of cards, with no engineering rules.

Two system power calculation methods are shown below. For configuring rectifiers as well as configuring reserve power, it is recommended to use typical current drain values.

### “Wired-for” method

This method is based simply on the number of modules and columns in the system, regardless of how many cards are initially equipped. This method will insure that the external power supply will have adequate capacity under all conditions and all possible **growth** scenarios within the modules installed.

Using Worksheet A, simply enter the quantity of each module, multiply by the power per module, and add up the total power. To calculate the current drain, divide by the nominal voltage. AC current is calculated by dividing 230 V ac nominal. DC current is calculated by dividing 52 V dc nominal. Both typical and maximum current may be calculated.

### “As-equipped” method

This method provides a way to tailor the system power supply more closely to the actual power consumption of the system as installed. The method is to take the Common Equipment power consumption as a constant, then add the power consumption for the actual PE cards equipped (or planned) from Tables 12 and 13.

Using Worksheet B and C, enter the quantity of each circuit pack, multiply by the power per card, and add up the total power. Enter these numbers into Worksheet D, and follow the same steps used above. AC current is calculated by dividing 230 V ac nominal. DC current is calculated by dividing 52 V dc nominal. Both typical and maximum current may be calculated.

### Notes on AC vs. DC systems

To calculate current drain at values other than the nominal values given in the worksheets, simply divide by the desired nominal value. For example, 208 V ac or 42 V dc.

For calculations normally done in apparent or complex power (such as AC wire and panel size, UPS rating for AC reserve power, etc.), simply divide the total real power (in Watts) by the typical system power factor of 0.6 to obtain the complex power (in VA).

40 Operating power requirements

---

**Worksheet A**  
**System power consumption - "Wired for"**

Module	Qty	Typical Power =	Qty	Maximum Power =
NT6D39	_____	x400= _____	_____	x420= _____
NT6D44	_____	x400= _____	_____	x 450 = _____
NT8D11	_____	x 500 = _____	_____	x690= _____
NT8D13	_____	x400= _____	_____	x 575 = _____
NT8D34	_____	x300= _____	_____	x 335 = _____
NT8D35	_____	x300= _____	_____	x325= _____
NT8D37	_____	x550= _____	_____	x720= _____
NT8D47	_____	x300= _____	_____	x 350 = _____
P e d e s t a l s	_____	x50= _____	_____	x 80 = _____

Typical Power (Watts) = \_\_\_\_\_

Max. Power (Watts) = \_\_\_\_\_

AC System Current Drain (Amps ac)

Nominal: Typical Power / 230= \_\_\_\_\_

Max. Power / 230 = \_\_\_\_\_

DC System Current Drain (Amps dc)

Nominal: Typical Power / 52 = \_\_\_\_\_

Max. Power / 52 = \_\_\_\_\_

**Worksheet B**  
**NT8D13 Power calculation**



Circuit Pack	Qty	x Power =	_____
QPC71F	_____	x 2.5 =	_____
QPC192B	_____	x 12.0 =	_____
QPC250B	_____	x 2.5 =	_____
QPC297	_____	x 7.1 =	_____
QPC422A	_____	x 10.9 =	_____
QPC430E	_____	x 14.8 =	_____
QPC432C	_____	x 10.2 =	_____
QPC449D	_____	x 15.6 =	_____
QPC450E	_____	x 7.0 =	_____
QPC578D	_____	x 24.6 =	_____
QPC594D	_____	x 32.8 =	_____
QPC659C	_____	x 40.4 =	_____
QPC723A	_____	x 14.8 =	_____
QPC789A	_____	x 26.4 =	_____

Total NT8D13 Power (Watts)= \_\_\_\_\_



**Worksheet C**  
**NT8D37 Power calculation**

Circuit Pack	<u>Qty</u>	x	Power =	_____
NT8D01AC	_____	x32=	_____	_____
NT8D01AD	_____	x32=	_____	_____
NT8D02AA	_____	x28=	_____	_____
NT8D03AA	_____	x 20 =	_____	_____
NT8D09AA	_____	x 20 =	_____	_____
NT8D14AA	_____	x36=	_____	_____
NT8D15AA	_____	x34=	_____	_____
NT8D16AA	_____	x 7 =	_____	_____
Total NT8D37 Power (Watts)=				_____



**Worksheet D**  
**System Power Consumption - "As equipped"**

Module	Qty	Typical Power = _____	otv	Maximum x Power = _____
NT6D39	_____	x400= _____	_____	x420= _____
NT6D44	_____	x400= _____	_____	x450= _____
NT8D11	_____	x500= _____	_____	x690= _____
NT8D13	(from Worksheet B) = _____		(from Worksheet B) = _____	
NT8D34	_____	x300= _____	_____	x335= _____
NT8D35	_____	x300= _____	_____	x 325 = _____
NT8D37	(from Worksheet C) = _____		(from Worksheet C) = _____	
NT8D47	_____	x300= _____	_____	x350= _____
P e d e s t a l s	_____	x50= _____	_____	x80= _____

Typical Power (Watts) = \_\_\_\_\_ Max. Power (Watts) = \_\_\_\_\_

AC System Current Drain (Amps ac)

Nominal: Typical Power / 230= \_\_\_\_\_ Max. Power / 230 = \_\_\_\_\_

DC System Current Drain (Amps dc)

Nominal: Typical Power / 52 = \_\_\_\_\_ Max. Power / 52 = \_\_\_\_\_



### Upgrades to existing installations

Total power consumption of an installed system can be determined in several different ways. Two methods are listed below, in order of decreasing accuracy.

- Measure current drain for **the** complete installation over at **least** a two-week period under actual operating conditions. Determine peak current drain from these measurements.
- Measure idle (or near idle) current drain for the complete installation. Estimate peak current drain by multiplying the number of idle amperes by 1.5.

When adding or upgrading equipment, use either of these methods to determine existing current drain/power consumption. Use **the** guideline in this document to determine the added power consumption. The existing power plant may have to be replaced or its capacity increased to accommodate the additional power requirements. As always, be sure to provide sufficient      capacity to accommodate planned growth of the SL-1 System.

Upgrades to existing systems may use either AC or DC equipment. Existing capacity, reserve power requirements, and available floor space are some of the factors to consider.

### Thermal considerations

The maximum power dissipation in the form of heat for each UEM is listed in Table 15. These figures apply to both AC and DC powered systems. The power figures listed here are different than those shown in previous tables for system power consumption, since some of the power, especially for peripheral equipment, is distributed out to the loops and sets and is not dissipated within the UEM itself. Table 16 shows the maximum heat dissipation for some of the external DC power equipment supplied by Northern Telecom.

**Table 15**  
**SL-1 system heat dissipation**

Module	Heat dissipation	
	Watts	BTU/hr
NT8D11 Common/Peripheral Equipment	450	1530
NT6D39 CPU/Network	400	1360
NT8D34 CPU	300	1020
NT8D35 Network	300	1020
NT8D13 Peripheral Equipment	300	1020
NT8D37 Peripheral Equipment	425	1450
NT8D47 Remote Peripheral Equipment	300	1020
NT6D44 Meridian Mail	400	1369
NT8D36 Junctor	0	0
<b>Note:</b> Thermal load (BTU/hr) = Total power dissipation (Watts) x 3.4		

**Table 16**  
**External power equipment heat dissipation**

Equipment	Heat Dissipation	
	Watts	BTU/hr
NT6D52AA 30A Rectifier	200	680
NT5C03 50A Rectifier	290	990
Note: Thermal load (BTU/hr) = Total power dissipation (Watts) x 3.4		



1



---

## Reserve power

---

Reserve power is available for both AC and DC systems. AC reserve power is provided by a separate Uninterruptible Power Supply (UPS), installed in series with the main system AC power feed. A UPS generally consists of a combination battery charger (AC-DC converter) and inverter (DC-AC converter), along with its associated batteries. The batteries may be internal or external to the UPS unit itself.

DC systems use the “traditional” telecommunications powering method of an external power plant consisting of rectifiers (AC-DC converters) continuously charging a bank of batteries, while the system power rails “float” in parallel on the battery voltage.

### AC reserve power

There are a wide variety of UPS vendors and systems available. Some of the factors to consider when choosing a UPS are:

- Input and output voltage and frequency range
- Number and type of output receptacles
- Regulatory and safety agency approvals
- Efficiency, crest factor, and other performance considerations
- Alarm and status indications
- Battery recharge time
- Backup time required
- Existing batteries or other power equipment at the site
- Planned system growth

### UPS sizing

Since power distribution for AC systems is provided on a per-column basis, partial system backup is available for all system options, thus reducing reserve power requirements. In other words, it is possible to back up all of the common equipment, but only a portion of the peripheral equipment, reducing both UPS and battery costs.

**Even** if it is desired to back up the entire system, the per-column powering allows the choice of provisioning one UPS per column, one UPS for the entire system (all columns), or any combination.

In order to determine the **size** of UPS needed, the total system (or column) power requirements are first determined as in the previous section “Operating power requirements.” The real power in Watts (**W**) is then converted to complex or “apparent” power in Volt-Amps (VA) by dividing the real power by the typical system power factor of 0.6. The UPS is then sized in terms of its rating in VA (or **kVA**).

The sizing and provisioning of the UPS batteries will be determined by following the specific instructions provided by the manufacturer of the **UPS** that has been selected. The general approach, however, is to take the total system power in Watts, divide by the UPS inverter efficiency, and convert to battery current drain by dividing by the nominal discharge voltage of the battery string. The battery current drain is then multiplied by the time that is needed for the reserve power to operate to determine the battery requirements in Amp-hours (A-hrs).

### Recommended UPS vendors and models

As of the publication date of this document, the following UPS systems have been tested by Northern Telecom and verified to work with the SL-1 system. These vendors and models meet high standards of both quality and functionality and are recommended to be used with the SL-1.

This list may change at any time in the future. Other UPS vendors may have products which work fine with SL-1 systems, and the vendors listed here may have other models and sizes that are also suitable. In particular, there are UPS systems larger than 10 **kVA** available that could be used with some of the larger system option 71 configurations.

**Table 17**  
**Verified UPS systems**

<b>Vendor</b>	<b>KVA Rating</b>	<b>Battery Voltage</b>
Alpha Technologies	1	48
Alpha Technologies	1.5	48
Alpha Technologies	3	48
Best Power Technoby	3	48
Best Power Technology	5	48
Exide Electronics	1.5	<b>120</b>
Exide Electronics	3	120
Exide Electronics	5	120
Exide Electronics	6	240
Exide Electronics	8	240
Exide Electronics	10	240

The UPS systems are available directly from the recommended vendors. For application assistance and direct sales information, the UPS vendor contacts in the U.S. are listed below:

**Alpha** Technologies, Inc.

3767 Alpha Way  
Bellingham, WA 98225  
(206) 647-2360  
Fax: (206) 671-4936

Best Power Technology, Inc.

P.O. Box 280  
**Necedah, WI 54646**  
(608) 5657200  
(800) 356-5794  
Fax: (608) 565-2221

Exide Electronics

3201 Spring Forest Road  
Raleigh, NC 27604  
(919) 872-3020  
Fax: (919) 878-1541

### Alarm Monitoring

A UPS to System Monitor Alarm cable is available from Northern Telecom for **each** of the recommended UPS vendors. The alarm interface consists of an “inverter on” signal to indicate that the commercial power is down and the UPS is supplying power to the system, and a “summary **alarm**” signal from the UPS to indicate a fault or alarm condition. The cables are listed below:

**Table 18**  
**UPS to System Monitor Alarm cables**

UPS vendor	NT part number
Alpha Technologies	NT8D46AU
Best Power Technology	NT8D46A.I
Exide Electronics	NT8D46AQ

### Installation

For UPS installation information, refer to the appropriate UPS vendor installation manual. It is recommended, however, that a UPS bypass switch be installed during the initial wiring if this switch function is not inherently a part of the UPS itself. The UPS bypass switch allows for the PBX to be run directly from commercial AC power while the UPS is taken off line during installation or service, or during battery maintenance.

#### CAUTION

Proper care must be taken when connecting the DC battery leads to the UPS. A battery reversal at the UPS can result in severe damage to the UPS.

A general block diagram of a UPS installation and associated wiring is shown in Figure 14.



Figure 14  
AC reserve power configuration

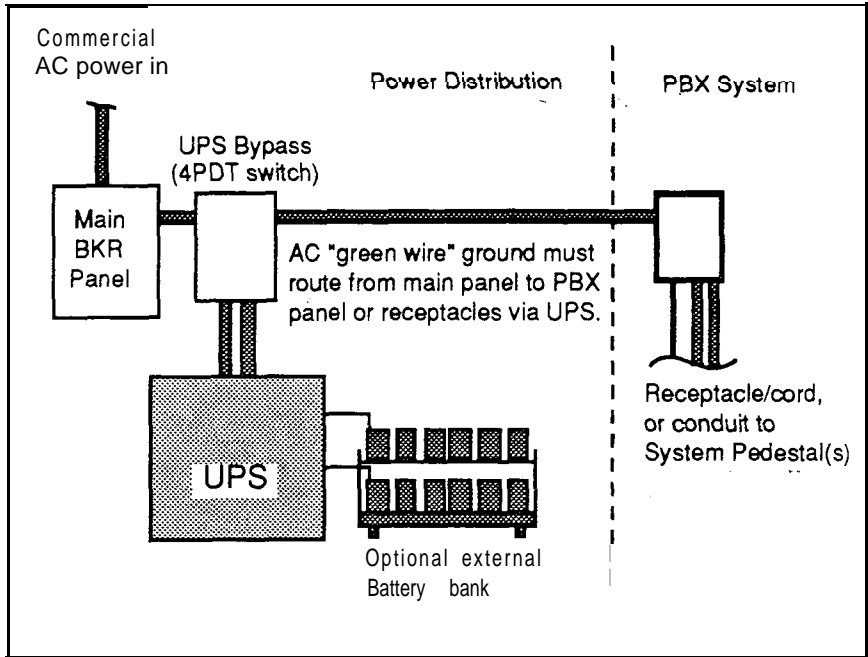

## DC reserve power

Reserve power for DC systems can be provided simply by adding batteries to the external distribution. The reserve battery capacity is determined by multiplying the system current drain by the time that is needed for the reserve power to operate. This will determine the total Ampere-Hour requirements of the batteries. Refer to Worksheets A through D.

The following guidelines should be used in determining DC reserve power requirements.

### Current required

When considering battery backup you should know with reasonable accuracy the total system power requirement.

For new installations, Northern Telecom provides the operating company with data listing the total current drain for each configured system. A rectifier and distribution panel which has the capacity to meet these current drain figures, and some added capacity to charge batteries can then be selected. For existing **installations**, the total current drain of an installed system can be calculated in several ways. Refer to "Operating power requirements" for more information.

The amount of reserve battery capacity depends on the system line size (load), the time the reserve supply must last in the event of power failure, and the battery end voltage.

### Batteries

Reserve batteries for a DC powered SL- 1 system must meet the following requirements as defined in Table 19.

**Table 19**  
**Battery requirements**

Battery configuration	Float voltage (V)		Equalize voltage (V)	
	cell	String	cell	String
24 stationary cells	-2.17	-52.08	-2.25	-54.08
23 sealed cells	-2.25	-51.75	-2.35	-54.05
24 sealed cells	-2.25	-54.00	-2.35	-56.40

The float and equalization voltages defined in Table 19 are not an exact requirement as long as voltages do not exceed -56.5 V. See Table 7 in “DC power description.”

Not all sealed cells require equalization, but the equalization voltage can be used for fast charging.

Batteries to be used with the SL-1 should be sized by using an end voltage of **44 V**.

The noise limitations for a battery string are:

- 20 mV rms maximum ripple
- 32 dBmC maximum noise

End cells and **CEMF** cells are not recommended because they are a noise source.

### **Other considerations**

-Planned growth

- Backup time required
- Existing power system capability
- Space and thermal conditions
- Other equipment, lights, alarm systems

---

## Engineering and configuration guidelines

---

Configuring the Meridian 1 power system requires attention to the following points:

- Both AC and DC-powering are available.
- The AC power supply or DC-DC Converter that is used in a particular module is virtually identical as far as external configuration purposes are concerned.
- Equipment Module power and cooling criteria are also the same for both AC and DC.
- A wide variety of Uninterruptible Power Supply (UPS) systems are available for AC-powered Meridian 1 systems that require reserve **power**.
- AC-powered systems, suited for those applications that do not need reserve power, require no external power components and connect directly to utility power.
- All DC systems can be configured as complete systems, with rectifiers provided by Northern Telecom. They can also be configured to connect to customer-provided external power.

AC and DC powering schemes differ primarily in the external power components (external, that is, to the Equipment Modules themselves).

The choice of which powering scheme to use is determined mainly by reserve power requirements and preferences, and by the existing power equipment at the site.

## AC power architecture

The internal AC power system consists of the following main elements:

- Pedestal Power Distribution Unit (PDU)
- Module Power Distribution Unit (MPDU)
- AC Power Supplies

No arbitrary selection of these components is required — they are included automatically in the System functional determination process.

There are three different AC power supplies that provide power to all of the common equipment, peripheral equipment, and combined common/peripheral equipment modules, as well as a ringing generator that provides AC ringing (and message waiting lamp voltages) when required for the peripheral equipment modules.

No additional external power components are required for AC-powered systems. Reserve power, if needed, is accomplished through the use of an external Uninterruptible Power Supply (UPS).

### Internal AC power equipment components

The following components are required to configure and AC powered system.

#### **Common Equipment Power Supply AC (NT8D29AA)**

The Common Equipment Power Supply AC is used in the Common Equipment modules in AC systems. It is located in the first slot on the left in the module labeled “CE Pwr Sup,” and converts 208/240 V ac to +5 V and  $\pm 12$  V dc, to provide all required voltages for CE and network circuit cards.

**Configuration guidelines** One Common Equipment Power Supply AC is used in each of the following AC modules:

- CPU Module (NT8D34AA)
- Network Module (NT8D35AA)
- CPU/Network Module (NT6D39AA)

**Peripheral Equipment Power Supply AC (NT8D06AA)**

The Peripheral Equipment Power Supply AC is used to provide power to all peripheral equipment modules in AC systems. It converts 208/240 V ac to +5 V, +8.5 V,  $\pm 10$  V,  $\pm 15$  V, and -48 V dc voltages used to power peripheral equipment logic cards and to supply "talk battery" to lines and trunks. This power supply is located in the far left hand card slot labeled "PE Pwr Sup."

**Configuration guidelines** One Peripheral Equipment Power Supply AC is used in each of the following AC modules:

- Intelligent Peripheral Equipment Module (NT8D37AA)
- Peripheral Equipment Module (NT8D13AA)

**Common/Peripheral Equipment Power Supply AC (NT7D14AA)**

The Common/Peripheral Equipment Power Supply AC converts 208/240 V ac to +5 V, +8.5 V,  $\pm 15$  V,  $\pm 12$  V, -48 V, -150 V dc, and 86 V ac/20 Hz ringing voltages used to power peripheral and common equipment, supply talk battery, and light Message Waiting lamps on 500/2500 sets. It is located in the left of the Module in the slot labelled "CE/PE Pwr sup. "

**Configuration guidelines** One Common/Peripheral Equipment Power Supply AC is used in each of the following AC modules:

- Common/Peripheral Equipment Module (NT8D11AB or NT8D11AC)
- Remote Peripheral Equipment Module (NT8D47AA)

**Ringing Generator AC (NT8D21AA)**

The AC Ringing Generator AC operates from a nominal 208/240 V ac input and provides selectable AC ringing voltage outputs superimposed on -48 V dc. The frequency and voltage options are 70 V ac at 25/50 Hz, 80 V ac at 25/50 Hz, and 86 V ac at 20/25. It also supplies -150 V dc message waiting lamp 500/2500 set applications. The Ringing Generator mounts in the PE modules to the right of the Peripheral Equipment Power Supply.

**Configuration guidelines** One Ringing Generator AC is used in each of the following, when these AC modules support 500- or 2500-type analog sets:

- Intelligent Peripheral Equipment Module (NT8D37AA)
- Peripheral Equipment Module (NT8D13AA)

### **Pedestal (NT8D27AB) \***

The Pedestal supports the column of Equipment Modules, and houses the Power Distribution Unit, the Blower Unit, and a reusable dust filter.

The Field Wiring Terminal Block is mounted in the bottom of the Pedestal.

#### **Configuration guidelines**

- One per column in AC systems
- The Field Wiring Terminal Block is factory wired with the following straps:
  - . LRTN - FGND

### **Power Distribution Unit (NT8D53AB)**

The AC Power Distribution Unit (PDU) distributes power to the entire column. It is located in the rear of the pedestal. It houses a main circuit breaker and the System Monitor.

**Configuration guidelines** One per Pedestal/column in AC systems

### **Module Power Distribution Unit (NT8D56AA)**

The NT8D56AA Module Power Distribution Unit (MPDU) protects the power supply and distributes power within a module. It houses a single breaker and is used in conjunction with the NT8D29AA Common Equipment Power Supply AC.

**Configuration guidelines** One per Module in AC systems

### **Module Power Distribution Unit (NT8D56AB)**

The NT8D56AB MPDU protects the power supply and distributes power within a module. It houses a single breaker and is used in conjunction with the NT7D14 Common/Peripheral Equipment Power Supply AC.

**Configuration guidelines** One per Module in AC systems

### **Module Power Distribution Unit (NT8D57AA)**

The NT8D57AA MPDU protects the power supply and distributes power within a module. It houses a dual breaker and is used in conjunction with the NT8D06AA PE Power Supply AC and the NT8D21AA Ring Generator AC.

**Configuration guidelines** One per **Module** in AC systems

## DC power architecture

The internal DC power system consists of **the** following main elements:

- Pedestal Power Distribution Unit (**PDU**)
- DC Power Converters

Like AC **systems**, there are three different DC power converters that provide power to all of the common equipment, peripheral equipment, and combined common/peripheral equipment Modules, as well as a ringing generator that provides AC ringing (and message waiting lamp voltages) when required for the peripheral equipment modules.

The external portion of DC-powered systems is generally referred to as the power plant, and mainly consists of the rectifiers and distribution equipment, as well as reserve batteries if required. For system options **21**, **51**, and **61**, Northern Telecom offers a power plant based on the **NT6D52AA** Rectifier, with an output capacity of 30A per rectifier, along with a rectifier/battery connection and distribution box (**QBL15**). For system option **71**, Northern Telecom offers the **QCA13** power plant based on the **NT5C03BJ** Rectifier, with an output capacity of 50A per rectifier, with a total system capacity of **500A**.

Customer-provided power is an option for all Meridian 1 systems. The **QBL12** Battery Distribution Box is available to connect a wide variety of customer-provided power equipment to the system.



## internal DC power equipment components.

The following components are required to configure and DC powered system.

### **Common Equipment Power Supply DC (NT6D41 AA)**

The Common Equipment Power Supply DC is used in the common equipment Modules in DC systems. It is located in the first slot on the left in the module labeled “CE Pwr Sup,” and converts -48 V **dc** to **+5 V** and **±12 V dc**, to provide all required voltages for CE and network circuit cards.

**Configuration guidelines** One Common Equipment Power Supply DC is used in each of the following DC modules:

- CPU Module (NT8D34DC)
- Network Module (NT8D35DC)
- CPU/Network Module (NT6D39DC)

### **Peripheral Equipment Power Supply DC (NT6D40AA)**

The Peripheral Equipment Power Supply DC is used to provide power to all peripheral equipment Modules in DC systems. It converts -48 V dc to **+5 V**, **+8.5 V**, **±10 V**, **±15 V**, and -48 V dc voltages used to power peripheral equipment logic cards and to supply “talk battery” to lines and trunks. This power supply is located in **the** far left hand card slot labeled “PE Pwr Sup”.

**Configuration guidelines** One Peripheral Equipment Power Supply DC is used in each of the following DC modules:

- Intelligent Peripheral Equipment Module (NT8D37DC)
- Peripheral Equipment Module (NT8D13DC)

### **Common/Peripheral Equipment Power Supply DC (NT7D04AA)**

The Common/Peripheral Equipment Power Supply DC converts 48 V dc to **+5 V**, **+8.5 V**, **±15 V**, **±12 V**, -48 V, and -150 V dc voltages used to power peripheral and common equipment, supply talk battery, and light Message Waiting lamps on **500/2500** sets. The supply provides the following selectable ringing voltage options: **70/80/86 V ac** at **20/25/50 Hz**. It is located in **the** left of the Module in the slot **labelled CE/PE Pwr Sup**.

**Configuration guidelines** One Common/Peripheral Equipment Power Supply DC is used in each of the following DC Modules:

- Common/Peripheral Equipment Module (NT8D11DC )
- Remote Peripheral Equipment Module (NT8D47DC)

### **RinginGeneratorDC(NT7D03AA)**

The AC Ringing Generator DC operates from a nominal -48 V dc input and provides selectable AC ringing voltage outputs superimposed on -48 V dc. The frequency and voltage options are 20/25/50 Hz and 70/80/86 V ac. It also supplies -150 V dc message waiting lamp 50012500 set applications. The Ringing Generator mounts in the PE modules to the right of the Peripheral Equipment Power Supply.

**Configuration guidelines** One Ringing Generator DC is used in each of the following, when these DC Modules support 500- or 2500-type analog sets:

- Intelligent Peripheral Equipment Module (NT8D37DC)
- Peripheral Equipment Module (NT8D13DC)

### **Pedestal (NT7D09AA)**

The Pedestal supports the column of equipment modules, and houses the Power Distribution Unit, the Blower Unit, and a reusable dust filter.

The Field Wiring Terminal Block is mounted in the bottom of the Pedestal.

**Configuration guidelines** One per column in DC systems

### **Power Distribution Uni(NT7D10AA)**

The DC Power Distribution Unit (PDU) distributes power to the entire column. It is located in the rear of the pedestal. It houses five circuit breakers (one for each module and one for the Blower Unit) and the System Monitor.

**Configuration guidelines** One per pedestal/column in DC systems

### **Module Power Distribution Unit**

Not applicable to DC systems.

## **External DC Power equipment components**

The following components are required to configure DC powered system.

**Switched Mode Rectifier -48V/30A (NT6D52AA)**

**Converts** 208/240 V ac (nominal) to -48 V dc (nominal), with a 30A output.

**Connects** to the system through the **QBL15** Battery Distribution Box. Based on QRF12.

**Configuration guidelines System** options 21/51/61 (DC versions).

Generally one rectifier per every two fully loaded modules. Exact quantity depends on system configuration and power requirements.

**Rectifier Rack Assembly (NT7D12AA)**

This is a **19-inch** open relay rack which is approximately 4'6" feet high. **It** supports up to three **NT6D52AA** Rectifiers.

**Configuration guidelines System** options 21/51/61 (DC versions). One rack per every three **NT6D52AA** Rectifiers, up to a maximum of two racks per system.

**Rectifier Baffle/Mounting Kit (NT7D1201)**

The Rectifier Baffle/Mounting Kit consists of a set of support brackets for mounting the **NT6D52AA** Rectifier to to **NT7D12AA** Rack, together with a heat baffle plate. The baffle directs exhaust air **from** the lower rectifier away from the inlet to the upper rectifier, thereby allowing cooling by natural convection.

**Configuration guidelines** System options **21/51/61** (DC versions). One per **NT6D52AA** Rectifier.

**Battery Distribution Box (QBL15)**

Allows the parallel connection of up to three **NT6D52AA** rectifiers, for connection to the SL-1 System and to reserve batteries. Includes main fuses, diode blocking, test points, QPC188 battery monitor card, and sense lead fusing on connections from each rectifier.

**Configuration guidelines** System options **21/51/61** (DC versions). One per every three **NT6D52AA** Rectifiers, up to a maximum of two Battery Distribution Boxes per system.

**Battery Distribution Box (QBL12)**

Connects customer-provided power equipment and batteries to the SL-1 System. Allows connection of up to 24 modules.

**Configuration guidelines** System option **71** (DC versions). Generally one per system.

**DC Power Plant (QCA13)**

Consists of a primary power cabinet with fusing and distribution hardware, monitoring and control, and up to four **NT5C03** 50A rectifiers. Up to two supplemental cabinets can be added, with up to four rectifiers in the **first** supplemental cabinet and up to two rectifiers in the second cabinet, for a total of 10 rectifiers and a total system capacity of 500A. (This power system is also referred to as the J2412 power **plant**; QCA13 is actually the cabinet designation, but is the more commonly used name.)

**Configuration guidelines** Used with system option 71 (DC version).  
**Quantity** as required by system power consumption.

**Switched Mode Rectifier - 48V/50A (NT5C03BJ)**

This is a solid state, switched-mode rectifier. Converts 208/240 V ac (nominal) to -48 V dc (nominal), with a 50A output. Used in the QCA13 power plant, with up to ten rectifiers in parallel.

**Configuration guidelines** Used with system option 71 (DC version).  
**Quantity** as required by system power consumption.

## Commercial power and grounding requirements

**Commercial power source** The commercial power source refers to the main AC utility power feed, for either AC-powered or DC powered systems. For AC systems, this power is wired directly to the system. For DC systems, this power source would connect to the rectifiers, which would convert to -48V dc for distribution to the system.

In North America, the power supplied can be either 208Y or 240 V ac nominal. Three phase is not required but single power feeds from alternate phases would be normal practice where three phase power is available. The following Table shows the exact input voltage range:

**Table 19**  
**AC power ranges**

Input	Minimum	Nominal	Maximum
Voltage (V ac) at pedestal	180	208/240	250
Frequency (Hz)	47	50/60	63

All power feeds used should contain a separate safety conductor (green wire). Northern Telecom strongly recommends that the supply conductors be dedicated and uninterrupted from a building primary source to a dedicated equipment room sub-panel.

**Power sub-panel** Power sub-panels must meet the following requirements or be modified when used for the Meridian 1:

- Panels should be located in the equipment room.

- No lighting, air conditioning, heating, generators or motors shall be serviced from this equipment room panel.
- In areas where isolated ground systems are permissible, this panel will provide sufficient ground connection points on the isolated ground plate or bar to handle the AC circuit grounds as well as the other ground reference conductors associated with the Meridian 1.

**Service receptacles** One dedicated outlet per pedestal (column) is a typical requirement for AC systems that are cord connected. For DC systems, or if reserve power is being used, the receptacles or conduit will serve the centralized rectifiers or UPS system directly, with power then routing to the columns.

Unless otherwise specified, these circuits should be rated for 30 Amps. All circuits must **be**:

- Wired and fused independently **of** all receptacles.
- Tagged at the power panel to prevent unauthorized interruption of power.
- Not controlled by a switch

The NEMA receptacle types are as follows:

- Isolated Ground systems:                   IG-L6-30
- Non-Isolated Ground systems:           **L6-30**

**System grounding requirements** Proper grounding is essential to **trouble-free** system operation and the safety of personnel. The Meridian 1 has several different grounds and signal returns that are generally referred to as grounds: logic return, battery return (for DC systems), AC “green wire” ground (in AC systems), and the personal hazard equipment ground.

The Meridian 1 does not, by design, need an AC Isolated Ground (IG) system (though this may be required by local codes), but it does need a single point ground system. This means that each of the various grounds, from each of the columns, should terminate at a single connection point before attaching to the actual ground reference at the main AC panel or transformer. The **single-point** ground may be implemented either by the use of the Isolated Ground bus in the AC panel, or by a separate logic return equalizing bus for battery returns, frame grounds, and logic returns where a non-isolated AC system is used.

The following must also be-observed to implement the single-point ground:

- All ground conductors must conform to local codes and terminate in a manner that is permanent, resulting in low impedance connections.
- All terminations should be accessible for inspection and maintenance.
- All grounding conductors must be continuous **with** no splices or junctions and tagged “WARNING - Ground Connection - Do not remove or disconnect.”
- Conductors should be insulated against contact **with** foreign grounds.
- Grounding conductors must be no-load, non-current carrying cables under normal operating conditions.
- The use of building steel as part of the ground system is not recommended.

The DC resistance of the system ground reference wire from the I to the building ground should be as close to zero as possible with the maximum total resistance on all runs, within the building, not to exceed 0.5 ohms. The insulated grounding wire size shall conform to **the** National Electric Code (NEC) 250-294, 250-295 and sections 310-316 (equivalent CSA requirements when used in Canada).

---

# Power conductors

---

## Wire size calculation guidelines

Determining wire gauges to connect a pedestal to a rectifier or other external distribution hardware is a very simple procedure, but it can be tedious if a lot of external components are involved. A programmable calculator or computer can help if it is going to be done often.

### **CAUTION**

#### **Do not over engineer the job!**

Too many wire gauges delivered to a site can cost more money than what will be saved in copper.

## The method

Using the maximum **current** in a conductor, determine the **length** that the conductor must be (remember that the vertical portions are sometimes longer than the horizontal portion) in order to meet the required maximum **voltage drop**.



### The formula

The following formula may be used to calculate the minimum wire size in Circular Mils (CM) required to connect any two points knowing current, distance and the desired drop for a specific cable:

$$CM = 11.1 \times I \times D / V$$

*where:* CM = wire size required in Circular Mils

I = current in amps (use the maximum expected)

D = distance in feet

V = Allowable voltage drop.

### Typical wire values

The following are typical values for circular mils and nominal maximum current for some of the more common wire sizes.

**Table 20**  
**Wire characteristics**

Wire gauge	CircMils	A max
4	41,750	90
6	26,250	65
<b>8</b>	16,510	50
10	10,380	35
12	6,530	25

Note: Maximum amperage is affected by many factors including temperature and insulation. Consult a wire handbook for precise tables.

**Table 21**  
**Maximum allowable voltage drops**

Conductor	From	To	V drop
- BAT	Pedestal	Dist. <b>DisChg</b>	1.0
+ BR	Pedestal	Dist. Corn	1.0
-BAT	Dist.	(-) Battery term	0.25
+ <b>BR</b>	Dist.	(+) Battery term	0.25
-BAT	Rectifier	<b>Dist. Chg</b>	0.5
+ BR	Rectifier	Dist. Corn	0.5

**Note 1:** Dist. is an abbreviation for Battery Distribution Box (i.e. **QBL15**, CtBLI2).

### CAUTION

Although **0.25/0.5/1.0** volts is the maximum drop allowed, the insulation and temperature rating vs current will often dictate a wire size that will create smaller voltage drops on short lengths. After using the formula, consult wire tables to ensure that the temperature rise is acceptable.

## Examples

The following three examples show how to make wire size calculations.

1. A Bat or BR conductor from the **QBL15** to a pedestal is 18 feet long and must carry a maximum of 36 Amps:

$$\text{Using } CM = 11.1 \times I \times D/V \quad CM = 11.1 \times 36 \times 18/0.5 = 14385.6$$

Choosing a standard gauge equal to or larger than this will mean 8 AWG which has a cross section of 16510 CM.

Up to 40 amps is allowable with 8 AWG even when the insulation is rated only 20 degrees C above the expected maximum ambient temperature.

2. A Bat or BR conductor from the **QBL15** to the Battery is 25 feet long and must carry a maximum of 70 Amps:

$$\text{Using } CM = 11.1 \times I_x \times D/V \quad CM = 11.1 \times 70 \times 25/0.5 = 38850$$

Choosing a standard gauge equal to or larger than this will mean 4 AWG which has a cross section of 41740 CM.

3. Example of the “Caution Note” for short distances - a Bat or BR conductor from the **QBL15** to the Rectifier is only 4 feet long and must carry a maximum of 25 Amps:

$$\text{Using } CM = 11.1 \times I_x \times D/V \quad CM = 11.1 \times 25 \times 4/0.5 = 2220$$

Choosing a standard gauge equal to or larger than this will mean 16 AWG which has a cross section of 2600 CM.

But, 16 AWG is nominally rated for only 13 Amps. In this case, 12 AWG which is rated at **25** Amps (but **with** only a 0.17 V drop over the 4 feet) is required.

### Sense lead wire size

The loop resistance of the wire used to connect the  $\pm$  Sense terminals to the TBC of the **QBL12** to the  $\pm$  terminals of the customer-provided batteries must not exceed 2.5 ohms.

### Simplified chart

Table 22 provides a simple means for determining the wire size between the distribution box and the pedestal.

Table 22 takes into account the two constraints of wiring into the pedestal.

- The loop voltage drop **from** the distribution point to the pedestal cannot exceed 2 V.
- The five wires (two **BAT/BR** pairs plus a logic return ) must physically fit inside a **3/4** inch conduit.

Additionally, the table assumes that the worst case current drain does not exceed 60 Amps per column. Other wire gauges can/should be used if the

column draws more **or** less than 60 Amps. Consult a wire handbook for precise calculations.

There are four options available for bringing wire into the pedestal:

**Single conduit** One  $3/4$  inch conduit access.

**Dual conduit** Two  $3/4$  inch conduit accesses.

**Junction box (single 4 AWG)** A junction box can be used to interface to one of the  $3/4$  inch conduit access points in the pedestal. Single runs of #4 AWG per feed are used between the junction box and the distribution point.

**Junction box (double 4 AWG)** This is the same as the case above, but double runs of #4 AWG per feed are used between the junction box and the distribution point.

**Table 22**  
**Pedestal wire guage requirements with two 30 A feeds (five'wiresj**

Length	Wire AWG			
	Single conduit	Dual conduit	Junction box with single #4 AWG*	Junction box with double #4 AWG*
	8	6	4	4
<b>0 - 10 ft</b>	Yes	Yes	Yes	Yes
<b>0-20ft</b>	Yes	Yes	Yes	Yes
<b>0-30ft</b>	Yes	Yes	Yes	Yes
<b>0 - 40 ft</b>	Yes	Yes	Yes	Yes
<b>0 - 50 ft</b>	Yes	Yes	Yes	Yes
<b>0-60ft</b>	No	Yes	Yes	Yes
<b>0 - 70 ft</b>	No	Yes	Yes	Yes
<b>0-80ft</b>	No	Yes	Yes	Yes
<b>0 - 90 ft</b>	No	No	Yes	Yes
<b>0 - 100 ft</b>	No	No	Yes	Yes
<b>0 - 200 ft</b>	No	No	No	Yes
<b>200 + ft</b>	No	No	No	No

Note 1: Two 30 A feeds are typically adequate for a full column of 4 modules (two 30 A feed pairs plus Logic return).

**Note 2:** When using dual conduit, the wires must be run in **BAT/BR** pairs. One pair in one conduit and one pair plus LRTN in the other conduit.

\* A single or double run of 4 AWG wire from the distribution point to a junction box near the pedestal. 10 AWG wire is run from the junction box into the pedestal PDU terminal board.

**Legend:** Yes = Wire size is adequate for the distance.  
 No = Wire size has too high a voltage drop and is inadequate for the distance.

---

## List of terms

---

<b>AC</b>	Alternating Current
<b>ACEG</b>	AC Equipment Ground
<b>AWG</b>	American Wire Gauge
<b>BAT</b>	Battery
<b>BR</b>	Battery Return
<b>bkr</b>	breaker (abbreviation)
<b>BRTN</b>	Battery Return
<b>CE</b>	Common Equipment
<b>CEC</b>	Canadian Electrical Code
<b>ckt</b>	circuit (abbreviation)
<b>CPC</b>	Common Product Code
<b>CSA</b>	Canadian Standards Association
<b>DC</b>	Direct Current
<b>DisChg</b>	Discharge
<b>EPE</b>	Existing PE
<b>FGND</b>	Frame Ground

<b>HZ</b>	Hertz (cycles per second)
<b>IG</b>	Isolated Ground
<b>inverter</b>	DC to AC converter
<b>LR</b>	Logic Return
<b>LRE</b>	Logic Return Equalizer
<b>MPDU</b>	Module <b>(UEM)</b> Power Distribution Unit
<b>mS</b>	millisecond
<b>NEC</b>	National Electrical Code (USA)
<b>P B X</b>	Private Branch Exchange
<b>Pcord</b>	Power Cord (abbreviation)
<b>PDU</b>	Power Distribution Unit (in pedestal)
<b>PE</b>	Peripheral Equipment (line card equipment)
<b>PEC</b>	Product Engineering Code
<b>PFTU</b>	Power Fail Transfer Unit
<b>Pwr</b>	Power (abbreviation)
<b>QBL12</b>	75 Amp external power distribution unit
<b>QBL15</b>	150 Amp external power distribution unit
<b>QCA13</b>	50 - 200 Amp rectifier/distribution (cabinet]
<b>QRF12</b>	25 Amp rectifier
<b>RPE</b>	Remotely located PE
<b>SPG</b>	Single Point Ground
<b>telco</b>	telephone company (abbreviation)

<b>UEM</b>	Universal <b>E</b> quipment Module
<b>UL</b>	Underwriters Laboratories
<b>UPS</b>	Uninterruptible Power System
<b>VAC,Vac</b>	Volts AC
<b>VDC.Vdc</b>	Volts DC
<b>Vpk</b>	Volts peak





SL-1

## **System options 21, 51, 61, 71**

Power engineering

Copyright © 1990 Northern Telecom

All rights reserved.

information subject to change without notice.

Release 1.0

Standard

January, 1990

Printed in U.S.A.



553-3001-153

SL-1

## System options 21, 51, 61, 71

Spares planning  
Standard

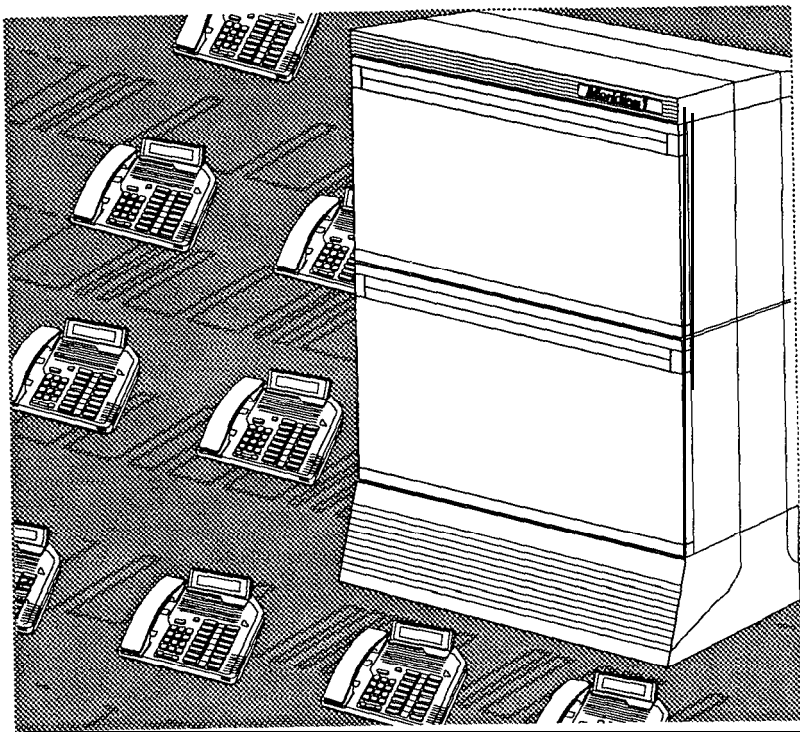

**nt** northern  
telecom

**Meridian1**  
Communication Systems



---

SL-1

# **System options 21, 51, 61, 71**

## **Spares planning**

---

Publication number: 553-3001-153

Document release: 1 .0

Document status: Standard

Date: January 29, 1990

---

© 1990 Northern Telecom

All rights reserved.

---

Spares planning 553-3001-I 53

---

# Revision history

---

**January 29, 1990**

Standard, release 1.0

---

# About this document

---

## General information

The Spares planning guide provides all the information necessary for the calculation and planning of spares (replaceable) items and provides failure rates for the SL-1 hardware.

The success of a maintenance program depends largely on the availability of an adequate stock of replaceable items. To ease maintenance and system reliability, follow the procedures given here for calculating spares stocks.

Spares requirements can be calculated to service SL-1 systems from a single depot (repair house) or a centralized depot serving subdepots. Read on for more information.

This document has been updated to include new naming conventions. Since the SL-1 is available in both AC and DC versions, the Product Engineering Code (PEC) is given, in some cases, for both AC and DC power options. The failure rates of some items may not appear in this release.

Note: Running the SL-1 system at lower temperature levels will increase the life expectancy of the components and improve overall system reliability.

## References

- See *the SL-1 planning & engineering guide* for
- **Muster index** (553-3001-000)
- **System overview** (553-3001-100)
- **Installation planning** (553-3001-120)

- **System engineering** (553-3001-151)
- **Power engineering** (553-3001-152)
- **Sparesplanning** (553-3001-153)
- **Equipment identification and ordering** (553-3001-154)

See the list of line and trunk circuit descriptions in **the Master index** (553-3001-000) for specific references to lines and trunks.

See the **SL-1 installation and maintenance guide** for

- **System installation procedures** (553-3001-210)
- **Circuit pack installation and testing** (553-3001-211)
- **Installation procedures for telephone sets and attendant consoles** (553-2201-215)
- **Extended systems installation** (553-3001-250)
- **Disk drive upgrade procedures** (553-3001-251)
- **General maintenance information** (553-3001-500)
- **Fault clearing** (553-3001-510)
- **Hardware replacement** (553-3001-520)

See the **SL-1 XII software guide** for an overview of software architecture, procedures for software installation and management, and a detailed description of all XI 1 features and services. This information is contained in two documents:

- **XII software management** (553-3001-300)
- **XII features and services** (553-3001-305)

See the **SL-1 XII input/output guide** (553-3001-400) for a description of all administration programs, maintenance programs, and system messages.



---

# Contents

---

<b>Spares planning</b>	<b>1</b>
Definitions and assumptions	1
Calculating spares requirements	5
<hr/>	
<b>Tables: NFT values</b>	<b>7</b>
<hr/>	
<b>Failure rates</b>	<b>15</b>





---

# Spares planning

---

## Definitions and assumptions

**Failure rate**-Failure rate equals the estimated number of failures for that item during one million ( $10^6$ ) hours of operation. The only exception is to measurements for cabling or other items with low failure rates. Rates are also measured in Failures in Time (FIT) measurements. One FIT equals one billion ( $10^9$ ) hours of operation.

**Sparing interval**-The sparing interval is the period of time that stocks of replaceable items should last without being replenished. This period is assumed to be one year following the installation of the system.

**Stock confidence level**-The stock confidence level is the allowed probability of not being out of stock when the sparing interval of one year is greater than 99.9 percent.

**Pack ambient temperature**-The pack ambient temperature is the average temperature of the air immediately surrounding the circuit pack (usually higher than the ambient room temperature). Pack failure rates in this document are based on a pack ambient temperature of  $40^{\circ}$  C.

## 2 Definitions and assumptions

---

**Turnaround time for rep&r-**The turnaround time for the return to stock of a failed item is about 10 working days (240 hours) from a repair house. (See Figure 1.)

**Figure 1**  
**Single depot or repair house service**

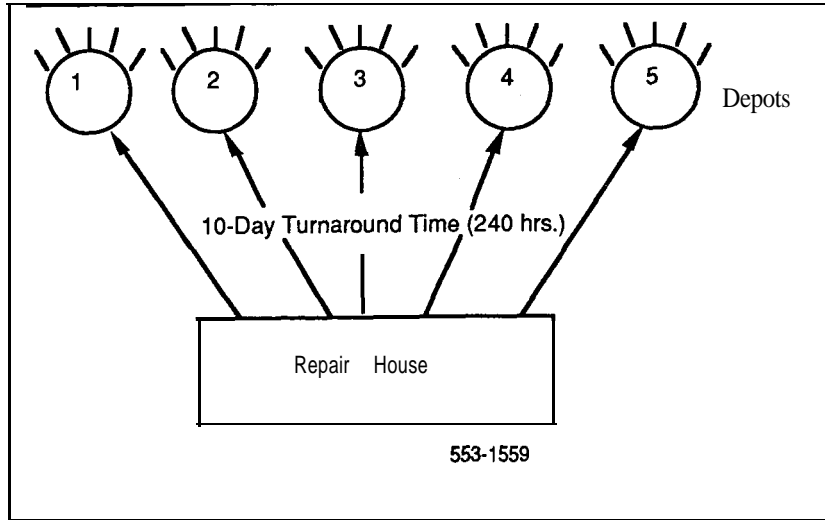

The turnaround time for the return to stock of a failed item is about two days from a centralized depot, (See Figure 2.)

**Figure 2**  
Centralized depot service

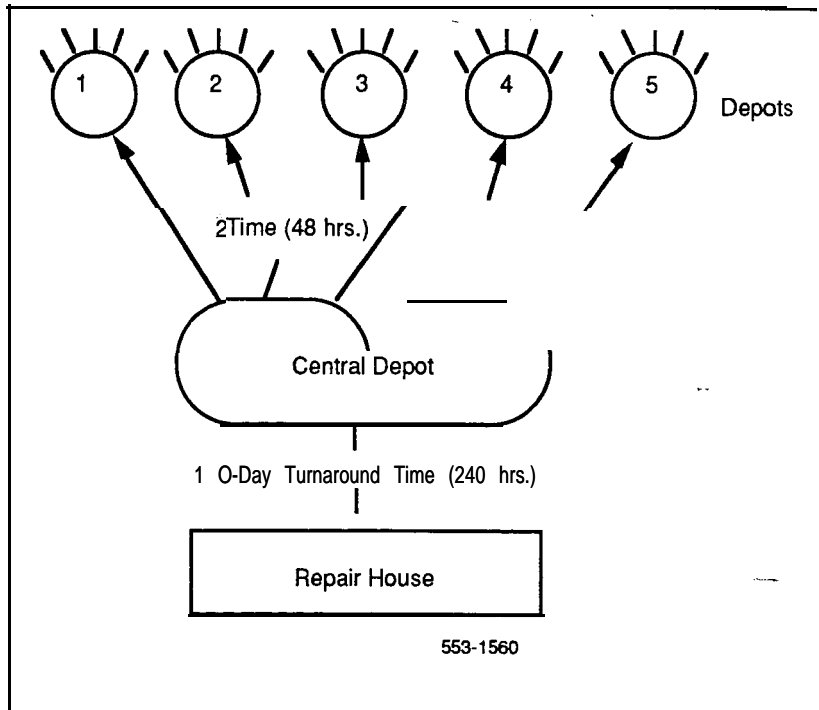

Actual turnaround periods Will vary in the field. As the number of systems served increases, the percentage of replaceable items required for stock is reduced. (See Figure 3.)

**Figure 3**  
Effect of turnaround on spares stock

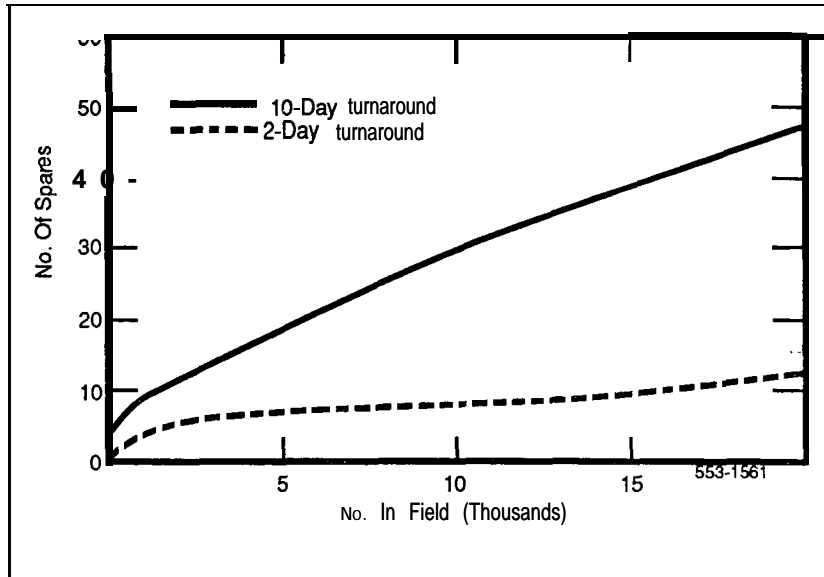

**Population range-**Population range is the quantity of each type of SL-1 switch in the area served by the depot.

**Spare stock size-**The quantity of spares for a given stock item depends on the sparing interval, stock confidence level, failure rate, turnaround time for repair, and population range.

## Calculating spares requirements

Replaceable items and their associated failure rates are listed in this document. Quantities of spares required to stock a depot for the one-year sparing interval can be calculated by following the procedures. Table 1 translates the **NFT** values to the number of spares required for that item. The following values are used:

N-The number of a spares item in use.

F-The failure rate for a particular spares item.

T-The turnaround time for repairing a failed spares item in hours.

Procedure 1 explains how to calculate the quantities of spares required to stock a depot for the one-year sparing interval:

**Procedure 1**

**Determining spares quantities to stock a depot for the one-year sparing interval**

- 1 Determine the number (N) of in-service specified circuit packs serviced by the depot.
- 2 Determine the pack failure rate (F) for the specified circuit pack in the Spares planning guide. (See Note 1 below.)
- 3 Determine turnaround time (T) in hours. (See Note 2 below.)
- 4 Calculate the NFT value by multiplying N x F x T.
- 5 Determine the number of spares required by using the NFT values in Table 4.

**Note 1:** Pack failure rates are expressed in terms of the number of failures per million hours.

**Note 2:** For a single depot or repair house service, turnaround time is typically 10 working days or 240 hours. For a centralized depot service, it is typically two days or 48 hours.

**For example:**

A single depot services 10,000 Peripheral Equipment Power Supply (PE Pwr Sup) (AC-NT8D06AA) (DC-NT6D41AB) packs. From the failure rates listed in Table 2, the failure rate for this pack is 1.84 failures per one million hours. If the turnaround time for a single depot is 48 hours, then:

$$\text{NFT} = 10,000 \times \frac{1.84}{1,000,000} \times 48 = 0.8832$$

From the NFT values in Table 1, the number of spares required for NFT value 0.8832 = 6. See Table 1.

## Tables: NFT values

Table 1  
Stock quantity of spares

NFT values		Number of spares	NFT values		Number of spares
0	0.0010	1	6.37	6.99	17
0.0010	0.0452	2	6.99	7.62	18
0.0452	0.1890	3	7.62	8.26	19
0.189	0.425	4	8.26	8.91	20
0.425	0.734	5	8.91	9.57	21
0.734	1.090	6	9.57	10.20	22
1.09	1.50	7	10.2	10.90	23
1.50	1.95	8	10.9	11.50	24
1.95	2.43	9	11.5	12.20	25
2.43	2.94	10	12.2	12.90	26
2.94	3.46	11	12.9	13.60	27
3.46	4.01	12	13.6	14.30	28
4.01	4.58	13	14.3	15.00	29
4.58	5.16	14	15.0	15.80	30
5.16	5.76	15	15.8	16.50	31
5.76	6.37	16	16.5	17.20	32

- continued -



8 Tables: NFT values

Table 1 continued  
Stock quantity of spares

NFT values		Number of spares	NFT values		Number of spares
17.2	17.9	33	29.2	30.0	49
17.9	18.7	34	30.0	30.8	50
18.7	19.4	35	30.8	31.6	51
19.4	20.1	36	31.6	32.4	52
20.1	20.9	37	32.4	33.2	53
20.9	21.6	38	33.2	33.9	54
21.6	22.4	39	33.9	34.7	55
22.4	23.1	40	34.7	35.5	56
23.1	23.9	41	35.5	36.3	57
23.9	24.6	42	36.3	37.1	58
24.6	25.4	43	37.1	37.9	59
25.4	26.2	44	37.9	38.7	60
26.2	26.9	45	38.7	39.5	61
26.9	27.7	46	39.5	40.3	62
27.7	28.5	47	40.3	41.1	63
28.5	29.2	48	41.1	41.9	64
—continued—					

Table 1 continued  
 Stock quantity of spares

NFT values		Number of spares	NFT values		Number of spares
41.9	42.7	65	55.0	55.8	81
42.7	43.5	66	55.8	56.6	82
43.5	44.3	67	56.6	57.5	83
44.3	45.2	68	57.5	58.3	84
45.2	46.0	69	58.3	59.1	85
46.0	46.8	70	59.1	60.0	86
46.8	47.6	71	60.0	60.8	87
47.6	48.4	72	60.8	61.6	88
48.4	49.2	73	61.6	62.5	89
49.2	50.0	74	62.5	63.3	90
50.0	50.9	75	63.3	54.1	91
50.9	51.7	76	64.1	65.0	92
51.7	52.5	77	65.0	65.8	93
52.5	53.3	78	65.8	66.6	94
53.3	54.2	79	66.6	67.5	95
54.2	55.0	80	67.5	68.3	96

-continued-

Table 1 continued  
 Stock quantity of spares

NFT values		Number of spares	NFT values		Number of spares
68.3	69.2	97	81.9	82.7	113
69.2	70.0	98	82.7	83.6	114
70.0	70.9	99	83.6	84.4	115
70.9	71.7	100	84.4	85.3	116
71.7	72.5	101	85.3	86.2	117
72.5	73.4	102	86.2	87.0	118
73.4	74.2	103	87.0	87.9	119
74.2	75.1	104	87.9	88.7	120
75.1	75.9	105	88.7	89.6	121
75.9	76.8	106	89.6	90.4	122
76.8	77.6	107	90.4	91.3	123
77.6	78.5	108	91.3	92.2	124
78.5	79.3	109	92.2	93.0	125
79.3	80.2	110	93.0	93.9	126
80.2	81.0	111	93.9	94.7	127
81.0	81.9	112	94.7	95.6	128
—continued—					

Table 1 continued  
 Stock quantity of spares

NFT values		Number of spares	NFT values		Number of spares
95.6	96.5	129	109.5	110.3	145
96.5	97.3	130	110.3	111.2	146
97.3	98.2	131	111.2	112.1	147
98.2	99.1	132	112.1	113.0	148
99.1	99.9	133	113.0	113.8	149
99.9	100.8	134	113.8	114.7	150
100.8	101.7	135	114.7	115.6	151
101.7	102.5	136	115.6	116.4	152
102.5	103.4	137	116.4	117.3	153
103.4	104.3	138	117.3	118.2	154
104.3	105.1	139	118.2	119.1	155
105.1	106.0	140	119.1	119.9	156
106.0	106.9	141	119.9	120.8	157
106.9	107.7	142	120.8	121.7	158
107.7	108.6	143	121.7	122.6	159
108.6	109.5	144	122.6	123.5	160
—continued—					

Table 1 continued  
 Stock quantity of spares

NFT values		Number of spares	NFT values		Number of spares
123.5	124.3	161	137.5	138.4	177
124.3	125.2	162	138.4	139.3	178
125.2	126.1	163	139.3	140.2	179
126.1	127.0	164	140.2	141.1	180
127.0	127.8	165	141.1	141.9	181
127.8	128.7	166	141.9	142.8	182
128.7	129.6	167	142.8	143.7	183
129.6	130.5	168	143.7	144.6	184
130.5	131.4	169	144.6	145.5	185
131.4	132.2	170	145.5	146.4	186
132.2	133.1	171	146.4	147.3	187
133.1	134.0	172	147.3	148.1	188
134.0	134.9	173	148.1	149.0	189
134.9	135.8	174	149.0	149.9	190
135.8	136.6	175	149.9	150.8	191
136.6	137.5	176	150.8	151.7	192
—continued—					

Table 1 continued  
Stock quantity of spares

NFT values		Number of spares	NFT values		Number of spares
151.7	152.6	193	165.9	166.8	209
152.6	153.5	194	166.8	167.7	210
153.5	154.4	195	167.7	168.6	211
154.4	155.2	196	168.6	169.5	212
155.2	156.1	197	169.5	170.4	213
156.1	157.0	198	170.4	171.3	214
157.0	157.9	199	171.3	172.2	215
157.9	158.8	200	172.2	173.1	216
158.8	159.7	201	173.1	174.0	217
159.7	160.6	202	174.0	174.9	218
160.6	161.5	203	174.9	175.8	219
161.5	162.4	204	175.8	176.7	220
162.4	163.3	205	176.7	177.5	221
163.3	164.1	206	177.5	178.4	222
164.1	165.0	207	178.4	179.3	223
165.0	165.9	208	179.3	180.2	224

—continued—

Table 1 continued  
 Stock quantity of spares

NFT values		Number of spares	NFT values	Number of spares	
180.2	181.1	225	194.6	195.5	241
181.1	182.0	226	195.5	196.4	242
182.0	182.9	227	196.4	197.3	243
182.9	183.8	228	197.3	198.2	244
183.8	184.7	229	198.2	199.1	245
184.7	185.6	230	199.1	200.0	246
185.6	186.5	231	200.0	200.9	247
186.5	187.4	232	200.9	201.8	248
187.4	188.3	233	201.8	202.7	249
188.3	189.2	234	202.7	203.6	250
189.2	190.1	235	203.6	204.5	251
189.2	190.1	236	204.5	205.4	252
191.0	191.9	237	205.4	206.3	253
191.9	192.8	238	206.3	207.2	254
192.8	193.7	239	207.2	208.1	255
193.7	194.6	240	208.1	209.0	256

---

## Failure rates

---

This section lists replaceable items used in SL-1s and provides their associated failure rates. Some failure rates are not available (N/A) at this time but will be offered in a supplement to this document. The replaceable items are grouped according to equipment types as follows:

- universal equipment modules
- cooling equipment
- circuit packs
- station equipment
- power equipment
- mass storage equipment

Note: The failure rates are based on a circuit pack ambient temperature of  $40^{\circ}$  C. This temperature is usually higher than the surrounding room temperature.



**Table 2**  
Failure rates of modules

PEC/NT Code	Description	Failure Rate per 10 <sup>6</sup> hrs
NT6D39AA NT6D39DC	CPU/Network Module	1.1
NT8D11AA NT8D11DC	Common/Peripheral Equipment Module	0.7
NT8D13AA NT8D13DC	Peripheral Equipment Module	0.5
NT8D34AA NT8D34DC	CPU Module	0.6
NT8D35AA NT8D35DC	Network Module	0.9
NT8D36AA	InterGroup Module	1.7
NT8D37AA NT8D37DC	Intelligent Peripheral Equipment Module	0.8
NT8D47AA NT8D47DC	Remote Peripheral Equipment Module	N/A

**Table 3**  
Failure rates of cooling equipment

PEC/NT Code	Description	Failure Rate per 10 <sup>6</sup> hrs
A0367754	Top Cap Fan	N/A
NT7D00AA	UEM Top Cap (AC)	.14
NT7D00BA	UEM Top Cap - Option 21A	.14
NT7D00DC	UEM Top Cap (DC)	.14
NT7D17AC	Fan Unit (AC)	6.14
NT7D17DC	Fan Unit (DC)	6.04
NT8D52AA	Blower Unit (AC)	2.00
NT8D52DC	Blower Unit (DC)	N/A

**Table 4**  
**Failure rates of circuit packs**

<b>PEC/NT Code</b>	<b>Description</b>	<b>Failure Rate per 10<sup>6</sup> hrs</b>
NT8D01AD	Controller-2	6.5
NT8D01AC	Controller-4	7.0
NT8D02AA	Digital Line Card	1.8
NT8D03AB	Analog Line Card	5.1
NT8D04AA	Superloop Network Card	5.1
NT8D09AB	Message Waiting Line Card	5.8
NT8D14AA	Universal Trunk Card	3.4
NT8D15AA	E&M Trunk Card	3.7
NT8D16AA	Digitone Receiver Card	2.7
NT8D17AA	Conference/Tone and Digit Switch (TDS) Card	5.1
NT8D18AA	Network/DigitoneReceiver Card	7.3
NT8D19AA	Memory/Peripheral Signaling Card	4.2
NT8D41AA	Serial Data Interface Paddle Board (Dual Port)	N/A
—continued—		

Table 4 continued  
Failure rates of circuit packs

PEC/NT Code	Description	Failure Rate per 10 <sup>6</sup> hrs
QPC43	Peripheral Signaling	1.73
QPC62	1.5M Baud Converter	9.60
QPC63	Local Carrier Buffer	7.04
QPC65	Remote Peripheral Switch	13.38
QPC66	2M Baud Converter	11.00
QPC67	Carrier Maintenance	9.20
QPC71	E&M/DX Signaling and Paging Trunk	3.10
QPC99	Carrier Interface	12.51
QPC130	CDR Tape Control	10.30
QPC139	Dual Serial Data Interface	1.67
QPC162	AIOD C25 Data Trunk	7.30
QPC164	Bus Terminating Unit	0.45
QPC192	Off-Premises Extension Line	12.97
QPC197	Tone and Digit Switch	
	—prior to vintage D	12.52
	—vintage D and later	5.04
QPC215	Segmented Bus Extender	2.20
QPC234	CDR ROM1	9.03
QPC235	CDR ROM2	8.34
QPC237	4-Wire E&M Trunk	1.50
QPC250	Release Link Trunk	7.73
QPC251	Tone and Digit Switch	2.33
QPC252	Tone and Digit Switch	14.66
QPC253	Tone and Digit Switch ( $\mu$ -Law)	14.66
QPC254	Tone and Digit Switch (A-Law)	14.66
--continued--		

Table 4 continued  
Failure rates of circuit packs

PEC/NT Code	Description	Failure Rate per 10 <sup>6</sup> hrs
QPC266	ACD Interface	0.37
QPC267	500 Line Message Waiting	11.33
QPC268	Control Interface and Memory (7 PROMS)	10.37
QPC271	Control and Timing	24.02
QPC272	CO and FX Trunk	10.90
QPC280	Conference (A-Law)	13.95
QPC284	500 Line Circuit (A-Law)	8.53
QPC285	SL- 1 Line Circuit (A-Law)	5.45
QPC286	500 Line Message Waiting (A-Law)	8.61
QPC287	E&M, DX, Paging Trunk (A-Law)	6.97
QPC288	Loop Signaling Trunk (A-Law)	7.09
QPC289	Recorded Telephone Dictation Trunk (A-Law)	8.19
QPC290	Recorded Announcement Trunk (A-Law)	5.61
QPC291	DIGITONE Receiver (A-Law)	6.68
QPC292	OPX 500 Line Circuit (A-Law)	12.75
QPC293	CO, FX Trunk Circuit (A-Law)	6.44
QPC294	Recorded Telephone Dictation Trunk (A-Law)	7.22
—continued—		

Table 4 continued  
Failure rates of circuit packs

PEC/NT Code	Description	Failure Rate per 10 <sup>6</sup> hrs
QPC295	CO, FX, MR DET Trunk Circuit (A-Law)	10.46
QPC296	4-Wire E&M Trunk (A-Law)	8.38
QPC297	Attendant Console Monitor ( $\mu$ -Law)	7.85
QPC301	CDR ROM	10.05
QPC302	Ground Button Recall Line	10.10
QPC311	Data Line Card	
	—prior to vintage F	13.91
	—vintage F and later	8.26
QPC319	RPE Processor (2 Mb/s RPE)	12.31
QPC320	Carrier Interface Circuit (2 Mb/s RPE)	7.93
QPC321	Phase Locked Loop	4.65
QPC322	Path Switch	2.78
QPC326	Daughter Board for Data Line Card	1.54
QPC327	MFC Sender/Receiver	20.07
QPC330	Buffered Message Register Trunk	9.78
QPC331	Buffered Message Register Trunk (A-Law)	16.64
—continued—		

Table 4 continued  
 Failure rates of circuit packs

PEC/NT Code	Description	Failure Rate per 10 <sup>6</sup> hrs
QPC353	Modem Pool Line Card ( $\mu$ -Law)	8.23
QPC342	Attendant Console Monitor (A-Law)	10.50
QPC343	Ground Button Recall Line (A-Law)	12.50
QPC354	Modem Pool Line Card (A-Law)	6.26
QPC357	Italian DID Trunk	12.64
QPC371	Codec Switched	0.45
QPC376	Dual Network	
	—vintage A	9.80
	—vintage B	8.01
QPC411	System Clock Generator	2.00
QPC412	Intergroup Switch	2.14
QPC414	Network Card	3.00
QPC417	Junctor Card	1.70
QPC422	Tone Detector	17.40
-continued-		

Table 4 continued  
Failure rates of circuit packs

PEC/NT Code	Description	Failure Rate per 10 <sup>6</sup> hrs
QPC432	Four Port Data Line Card	8.15
QPC441	Three-Port Extender	2.00
QPC443	Control and Timing	9.62
QPC444	Conference Card	3.20
QPC446	$\mu$ -Law Conference (Warning Tone)	11.20
QPC449	Loop/DID Signaling Trunk	2.27
QPC450	$\mu$ -Law CO/FX/Wats Trunk	3.34
QPC451	SL-1 Line ( $\mu$ -Law)	5.15
QPC452	500/2500 Line ( $\mu$ -Law)	
	—prior to vintage C	8.70
	—vintage C and later	5.20
QPC464	Peripheral Buffer	9.00
QPC471	Clock Controller	2.44
QPC472	Digital Trunk Interface	6.00
QPC473	DTI Carrier Interface	6.60
QPC475	Digitone Receiver	3.10
QPC477	Bus Terminating Unit	0.64
-continued-		

Table 4 continued  
 Failure rates of circuit packs

PEC/NT Code	Description	Failure Rate per 10 <sup>6</sup> hrs
QPC494	500/2500 Message Waiting	8.00
QPC496	Extender	0.69
QPC500	PE Backplane	3.24
QPC501	PE Backplane	3.24
QPC503	CE Backplane	3.24
QPC513	Enhanced Serial Data Interface Card	6.00
QPC526	PPM CO Trunk (A-law)	16.82
QPC527	CO/FX/WATS trunk (A-law)	12.37
QPC528	CO/IX/WATS trunk - (EIA)	14.23
QPC532	Grd Button Line Card	13.93
QPC536	Digital Trunk Interface	12.36
QPC540	Tone Detector	6.49
—continued—		



Table 4 continued  
Failure rates of circuit packs

PEC/NT Code	Description	Failure Rate per 10 <sup>6</sup> hrs
QPC578	Integrated Services Digital Line	2.72
QPC579	CPU Function	2.60
QPC580	CPU Interface	3.36
QPC581	Changeover and Memory Arbitrator	2.80
QPC583	Memory	2.93
QPC585	Power Converter	2.63
QPC591	Double Density Line	6.22
QPC594	16-Port 500/2500 Line	3.70
QPC595	Dual DT Receiver (A-law)	6.28
QPC602	Read-Only Memory	3.2
QPC609	Tone and Digit Switch	2.33
QPC611	Tone and Digit Switch with Centralized Attendant Service (CAS)	10.67
QPC628	CO Loop Start Supervisory Trunk	7.41
QPC659	Dual Loop Peripheral Buffer	2.75
—continued—		

Table 4 continued  
Failure rates of circuit packs

PEC/NT Code	Description	Failure Rate per 10 <sup>6</sup> hrs
Q1C673	512K RAM Memory Card	5.04
QPC674	256K Memory with Error Correction	5.80
QPC706	Half PE Expansion Power Converter, 1st tier	1.14
QPC710	$\mu$ -Law Digitone Receiver	5.20
QPC720	Primary Rate Interface Card	6.00
QPC723	RS-232 Interface Line Card	N/A
QPC757	D-Channel Handler Interface Card	N/A
QPC775	Clock Controller Card	2.44
QPC789	16-Port 500/2500 Line (Message Waiting)	N/A
QPC814	Memory	N/A
QPC841	Four-Port Serial Data Interface Card	2.2
QPC918	High-Speed Data Card	N/A
QPC939	Read-Only Memory	N/A
QPC940	Read-Only Memory	N/A

**Table 5**  
**Failure rates of station equipment**

<b>PEC/NT Code</b>	<b>Description</b>	<b>Failure Rate per 10<sup>9</sup> hrs</b>
	M1250 Console	N/A
	M2250 TCM Console	N/A
	<b>M2006</b> Digital Telephone	N/A
	<b>M2008</b> Digital Telephone	3.10
	<b>M2016S</b> Digital Telephone	3.90
	M2216 Digital Telephone	N/A
	M2616 <b>D</b> igital Telephone	N/A
	<b>M3000</b> Touchphone	N/A
<b>NE-500/2500</b>	<b>500/2500</b> Telephone Set	N/A
<b>NE-DGQC-35</b>	Line Cord	3.50
<b>NE-G3AR-35</b>	Handset	0.50
<b>NE-G3DRN-3</b>	Console Handset	0.50
<b>NE-T1</b>	Transmitter	0.50
<b>NE-U1</b>	Receiver	0.50
<b>NT1F05AA</b>	<b>M2009</b> Digital Tel Set	12.22
<b>NT1F06AA</b>	M2012 Digital without hands free	12.44
<b>NT1F06AA</b>	<b>M2112</b> Digital with hands free	14.04
<b>NT1F07AA</b>	<b>M2018</b> Digital	13.36
<b>NT1F11AA</b>	<b>M3000</b> Touch Phone	21.01
—continued—		

Table 5 continued  
Failure rates of station equipment

PEC/NT Code	Description	Failure Rate per 10 <sup>6</sup> hrs
QKK1	Handsfree Interface/Remote Powering Kit	0.33
QKK3	Automatic Handsfree Interface Kit	0.82
QKN1	Headset Kit	0.25
QMT1	10-Button Key Lamp Expansion Module	2.89
QMT2	20-Button Key Lamp Expansion Module	4.73
QMT3	Lamp Field Array Module	13.99
QMT4	Handset Module	0.50
QMT11	Asynchronous/Synchronous Interface Module	6.34
QMT12	Add-On Data Module	9.92
QMT15	Amplified Handset Module	N/A
QMT21	High-Speed Data Module	N/A
QPF23	Terminating Plug	0.16
QSAM2/3	Group Listening Switch Kit	0.50
QSR2	Venture 1 Headset	N/A
QSU1E	SL-1 Telephone Set (Phase I)	14.64
QSU1F	SL-1 Telephone Set (Phase II)	13.09
QSU1G	SL-1 Telephone Set (Phase III)	11.48
QSU3C	SL-1 Telephone Set (16-Digit Display)	19.16
QSU3D	SL-1 Telephone Set (16-Digit Display)	19.16
QSU6	ACD Telephone Set	13.57
QSU7	ACD 16-Digit Display Telephone Set	14.37
QSU60	SL-1 Telephone Set (U.S. Model)	13.18

Table 6  
Failure rates of power equipment

PEC/NT Code	Description	Failure Rate per 10 <sup>6</sup> hrs
NT5C03BJ	Switched Mode Rectifier -48V/50A	N/A
NT6D40AA	DC Peripheral Equipment Power Supply	1.6
NT6D41AA	DC Common Equipment Power Supply	0.6
NT6D52AA	Switched Mode Rectifier -48V/30A	1.2
NT7D03AA	DC Ringing Generator	1.81
NT7D04AA	DC Common/Peripheral Equipment Power Supply	3.14
NT7D10AA	DC Power Distribution Unit	N/A
NT7D12AA	Rectifier Rack	N/A
NT7D14AA	AC Common/Peripheral Equipment Power Supply	2.34
NT7D15AA	System Monitor - Option 21A	N/A
NT8D06AA	AC Peripheral Equipment Power Supply	2.1
NT8D21AA	AC Ringing Generator	2.02
NT8D22AB	System Monitor	1.0
NT8D29AA	AC Common Equipment Power Supply	1.27
NT8D39AA	Power Failure Transfer Unit	5.7
NT8D53AB	AC Power Distribution Unit	N/A
NT8D53AD	Power Distribution Unit Option 21 A	N/A
NT8D56AA	Module Power Distribution Unit	N/A
NT8D56AB	Module Power Distribution Unit	N/A
NT8D57AA	Module Power Distribution Unit	N/A
—continued—		

Table 6 continued  
Failure rates of power equipment

PEC/NT Code	Description	Failure Rate per 10 <sup>6</sup> hrs
NT8D62AA NT8D62DC	Temperature Sensor Panel	N/A
QBL12	Battery Distribution Box	1.10
QBL15	Power/Battery Distribution Box	2.81
QCA13	DC Power Plant	N/A
QCA321	Junction Box	N/A
QPC188	Battery Monitor	N/A
QRF12	48V Rectifier	1.20
QRF12	I-52V Rectifier	N/A

Table 7  
Failure rates of mass storage equipment

PEC/NT Code	Description	Failure Rate per 10 <sup>6</sup> hrs
NT8D68AA	Floppy Disk Unit	46.00
NT8D69AA	Multi-Disk Unit	65.00
QMT102	Disk Drive Controller	3.23
QMT103	Hard Disk Drive (Winchester)	16.31
QMT104	Floppy Disk Drive	22.83
QPC584	Mass Storage Interface	2.26
QPC742	Floppy Disk Interface	3.23

**Note:** There are many replacement cables (not listed here) in lengths appropriate for various configurations available from Northern Telecom. The approximated failure rates for most cables are the same (0.50); the measurement is based on failures in time per billion hours (FIT) or 10<sup>9</sup>. For a detailed listing of the cables available from Northern Telecom, see *Equipment identification and ordering* (553-3001-154).

SL-1

## **System options 21, 51, 61,71**

Spares planning

Copyright © 1990 Northern Telecom  
All rights reserved.  
Information subject to change without notice.  
Release 1.0  
Standard  
January 29, 1990  
Printed in U.S.A.



553-3001-154

SL-1

## System options 21, 51, 61, 71

Equipment identification and  
ordering information

Standard

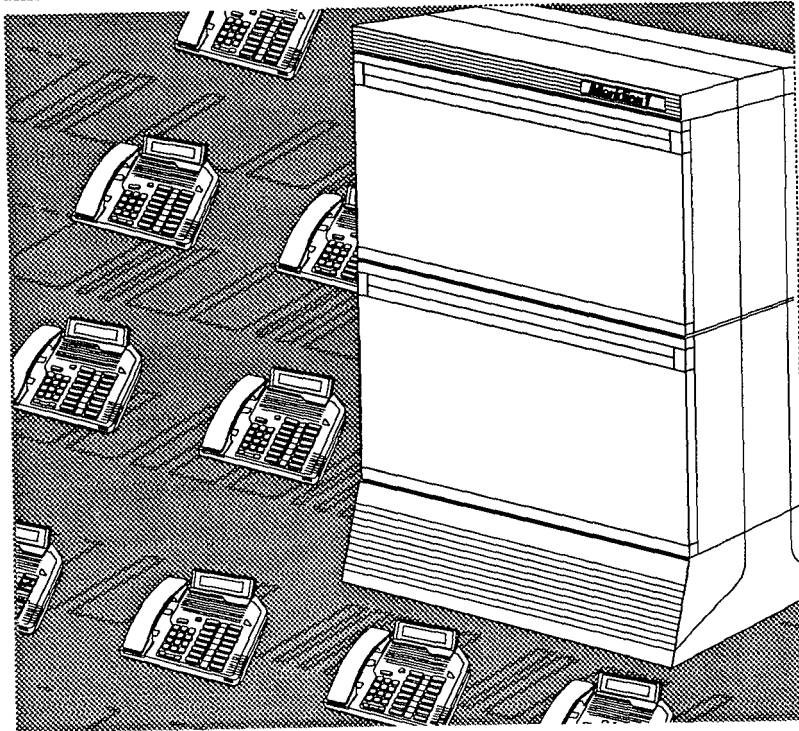

**nt** northern  
telecom

**Meridian 1**  
Communication Systems





4





---

SL- 1

# **System options 21, 51, 61, 71**

Equipment identification and ordering information

---

Publication number: 553-3001-154

Document release: 1 .0

Document status: Standard

Date: January **29, 1990**

---



© 1990 Northern Telecom

All right reserved

---

Equipment identification and ordering information 553-3001-154

ii

---

# Revision history

---

**January 29, 1990**

Standard, release 1.0

---

## About this document

---

This document identifies equipment of the Meridian 1 System options 21, 51, 61, 71 that can be ordered individually. The items are described in terms of purpose, quantity required, and system hardware (system option), as appropriate.

### References

See the *SL-1 planning & engineering guide* for

- *Master index* (553-3001-000)
- *System overview* (553-3001-100)
- *Installation planning* (553-3001-120)
- *System engineering* (553-3001-151)
- *Power engineering* (553-3001-152)
- *Sparesplanning* (553-3001-153)

See the list of line and trunk circuit descriptions in *the Master index* (553-3001-000) for specific references to lines and trunks.

See the *SL-1 installation and maintenance guide* for

- *System installation procedures* (553-3001-210)
- *Circuit pack installation and testing* (553-3001-211)
- *Installation procedures for telephone sets and attendant consoles* (553-3001-215)
- *Extended systems installation* (553-3001-250)
- *Disk drive upgrade procedures* (553-3001-251)

— **General maintenance information** (553-3001-500)

— **Fault clearing** (553-3001-510)

— **Hardware replacement** (553-3001-520)

**See the SL-1 XI1 software guide** for an overview of software architecture, procedures for software installation and management, and a detailed description of all XI 1 features and services. This information is contained in two documents:

— **XI1 software management** (553-3001-300)

— **XI1 features and services** (553-3001-305)

**See the SL-1 XI1 input/output guide (553-3001-400)** for a description of all administration programs, maintenance programs, and system messages.

---

# Contents

---

<b>General</b>	<b>1</b>
Equipment packages	1
Conversion and expansion packages	1
Equipment availability	2
Special features	2
Product coding	2
<hr/>	
<b>Universal Equipment Modules and packaging</b>	<b>5</b>
NT6D39AA, NT6D39DC CPU/Network Module	5
NT6D44AA, NT6D44DC Meridian Mail Module	6
NT8D11AC, NT8D11DC CE/PE Module	7
NT8D13AA, NT8D13DC Peripheral Equipment Module	-- 8
NT8D34AA, NT8D34DC CPU Module	8
NT8D35AA, NT8D35DC Network Module	9
NT8D36AA Inter Group Module	10
NT8D37AA, NT8D37DC Intelligent PE Module	10
NT8D47AA, NT8D47DC Remote PE Module	11
NT8D49 Spacer Kit	12
NT8D55AA Universal Equipment Module cover	12
Universal Equipment Module side panel	12
Card cage assemblies	12
Top Cap	13
Pedestal	13
<hr/>	
<b>Power and cooling equipment</b>	<b>15</b>
A0367754 Top Cap Fan	15
NT5C03BJ Switched Mode Rectifier -48V/50A	15
NT6D40AA Peripheral Equipment Power Supply DC	15
NT6D41 AA Common Equipment Power Supply DC	16

---

NT6D52AA	Switched Mode Rectifier -48V/30A	16
NT6D53AA	Junction Box	17
NT6D5303	Logic Return Equalizer	17
NT7D0003	Fan and Sensor Panel	<b>17</b>
NT7D03AA	Ringing Generator DC	<b>18</b>
NT7D04AA	CE/PE Power Supply DC	18
NT7D10AA	Power Distribution Unit DC	18
NT7D12AA	Rectifier Rack	19
NT7D14AA	CE/PE Power Supply AC	19
NT7D15AA	System Monitor - System option 21 A	19
NT7D17AC	Fan Unit AC	20
NT7D17DC	Fan Unit DC	20
NT7D1201	Rectifier Baffle/Mounting Kit	20
NT8D06AA	Peripheral Equipment Power Supply AC	20
NT8D21 AA	Ringing Generator AC	21
NT8D22AB	System Monitor	21
NT8D29AA	Common Equipment Power Supply AC	<b>22</b>
NT8D39AA	Power Failure Transfer Unit	22
NT8D52AA	Blower Unit	23
NT8D52DC	Blower Unit	23
NT8D53AB	Power Distribution Unit AC	23
NT8D53AD	Power Distribution Unit - System option 21A	24
NT8D56AA	Module Power Distribution Unit	24 --
NT8D56AB	Module Power Distribution Unit	24
NT8D57AA	Module Power Distribution Unit	24
NT8D62AA, NT8D62DC	Temperature Sensor Panel	25
QBL12	Battery Distribution Box	25
QBL15	Power/Battery Distribution Box	26
QCA13	DC Power Plant	26
QPC188	Battery Monitor	26
QRF12	-52 V Rectifier	27

---

<b>Common Equipment cards</b>	<b>29</b>	
NT8D04AA	Superloop Network	29
NT8D17AA	Conference/Tone and Digit Switch (TDS)	29
NT8D18AA	Network/Digitone Receiver	30
NT8D19AA	Memory/Peripheral Signaling	30
NT8D41AA	Serial Data Interface paddle board (Dual Port)	30
NT8D68AA	Floppy Disk Unit	31
NT8D69AA	Multi Disk Unit	31

---

QMM42 Security Data Cartridge	32
QPC43 Peripheral Signaling	32
QPC215 Segmented Bus Extender	32
QPC412 Intergroup Switch	32
QPC414 Network	33
QPC417 Junctor Board	33
QPC441 Three-Port Extender	33
QPC471 Clock Controller	33
QPC477 Bus Terminating Unit	34
QPC513 Enhanced Serial Data Interface	34
QPC579 CPU Function	35
QPC580 CPU Interface	35
QPC581 Changeover and Memory Arbitrator	35
QPC583 Memory	35
QPC584 Mass Storage Interface	36
QPC687 CPU with SDI/RTC	36
QPC720 Primary Rate Interface	36
QPC742 Floppy Disk Interface	37
QPC757 D-Channel Handler Interface	37
QPC841 Four-Port Serial Data Interface	37
QPC939 Read-Only Memory	38
QPC940 Read-Only Memory	38

---

<b>Peripheral Equipment cards</b>	<b>39</b>
NT8D01 AD Controller-2	39
NT8D01 AC Controller-4	39
NT8D02AA Digital Line card	40
NT8D03AB Analog Line card	40
NT8D09AB Analog Message Waiting Line card	40
NT8D14AA Universal Trunk	41
NT8D15AA E&M Trunk	42
NT8D16AA Digitone Receiver	43
QPC62 1.5 Baud Converter	43
QPC63 Local Carrier Buffer	43
QPC65 Remote Peripheral Switch	44
QPC66 2M Baud Converter	44
QPC67 Carrier Maintenance	45
QPC71 E&M/DX Signaling and Paging Trunk	45
<b>QPC99</b> Carrier Interface	46
QPC192 Off-Premises Extension Line	46

---



---

QPC237 4-wire <b>E&amp;M/DX</b> signaling trunk	46
QPC250 Release Link Trunk	47
QPC297 Attendant Console Monitor	47
QPC422 Tone Detector	47
QPC430 Asynchronous Interface Line	48
QPC432 <b>4-Port</b> Data Line	48
<b>QPC449</b> Loop Signaling Trunk	48
QPC450 <b>CO/FX/WATS</b> Trunk	49
QPC578 Integrated Services Digital Line	49
<b>QPC594 16-Port 500/2500</b> Line	49
QPC659 Dual Loop Peripheral Buffer	49
QPC723 RS-232 4-Port interface Line	50
QPC789 16-Port <b>500/2500</b> Line (Message Waiting)	50
QPC918 High-Speed Data Card	50

---

<b>Station equipment</b>	<b>51</b>
Meridian Modular Telephones	<b>51</b>
M2000 series digital telephones	60
<b>M3000 Touchphone</b>	61
<b>NE-500/2500</b> telephone set	61
MI 250 and 2250 attendant consoles	61
Attendant administration overlay template	62
<b>QMT1</b> and <b>QMT2</b> key/lamp expansion modules	62
QMT3 lamp field array module	62
QMT4 handset module	62
<b>QMT1 1 asynchronous/</b> synchronous interface module	63
QMT12 add-on data module	63
<b>QMT15</b> amplified handset module	63
QMT21 high-speed data module	63
<b>QUS1</b> logic handsfree unit	64
<b>QKK1</b> handsfree remote powering kit	64
QKK3 automatic handsfree interface kit	64
QKK8 automatic handsfree interface kit	64
QKM13 light probe kit	64
<b>QKN1</b> headset kit	64
QSR2 venture 1 headset	65
<b>QSAM2A</b> and <b>QSAM3A</b> group listening switch kit	<b>65</b>
Asynchronous data options	65
<b>Meridian</b> programmable data adapter	66
<b>Teledapt™</b>	67

---

Station equipment replaceable items	67
<hr/>	
<b>Cabling</b>	<b>71</b>
NT7D11 AE module-to-module power harness	71
NT8D40AA AC power cord	72
NT8D40AM module-to-module power-harness	72
NT8D40AY AC power cord	72
NT8D40BJ System Monitor to backplane cable	72
NT8D40BK System Monitor trip cable	72
NT8D46AA System Monitor column cable	72
NT8D46AC Thermostat harness	72
NT8D46AD System Monitor SDI cable	73
NT8D46AG System Monitor to SDI paddle board cable	73
NT8D46AH System Monitor to MDF cable	73
NT8D46AJ System Monitor to UPS (Best) cable	73
NT8D46AL System Monitor Serial Link cable	73
NT8D46AM Air Probe harness AC	73
NT8D46AP Extended System Monitor Serial Link cable	74
NT8D46AQ System Monitor to UPS (Exide) cable	74
NT8D46AS System Monitor inter-CPU cable	74
NT8D46AT System Monitor to QBL15 cable	74
NT8D46AU System Monitor to UPS (Alpha) cable	74
NT8D46AV System Monitor to QCA13 cable	74
NT8D46AW System Monitor to QBL12 cable	75
NT8D46DC Air Probe harness DC	75
NT8D73 Inter-cabinet Network cable	75
NT8D74 Clock Controller to Inter Group cable	75
NT8D75 Clock Controller to Clock Controller cable	76
NT8D76 Intergroup Switch to Inter Group cable	76
NT8D77 FDI to FDU cable	76
NT8D78AA CPU cable	77
NT8D79 PRI/DTI to Clock Controller cable	77
NT8D80 CPU interface cable	77
NT8D81 AA Tip and Ring cable	78
NT8D82 SDI to I/O cable	78
NT8D83 PRI/DTI to I/O cable	78
NT8D84AA SDI paddle board (Dual Port) to I/O cable	79
NT8D85 Network to PE cable	79
NT8D86 Network to I/O cable	79
NT8D87 Conference/TDS to music trunk cable	80

---

NT8D88	Network to I/O cable	80
NT8D90AF	SDI multiple-port cable - internal	80
NT8D91	Network to Controller cable	81
NT8D92AB	Controller to I/O cable	81
NT8D93	SDI paddle board (Dual Port) I/O to DTE/DCE cable	81
NT8D95	SDI I/O to DTE/DCE cable	82
NT8D97AX	PRI/DTI I/O to MDF cable	82
NT8D98	Inter-cabinet Network cable	82
NT8D99	CPU to Network cable	83
NT9J93AD	PRI/DTI Echo Cancellor to I/O cable	83
NT9J94AB	RPE to I/O cable	83
NT9J96	Intra-cabinet Network cable	83
NT9J97	Intra-column Network cable	84
NT9J98	Intra-cabinet Network cable	84
NT9J99	Intra-cabinet Network cable	84
QCAD128	connector cable	85
QCAD274A	AC power cord	85

---

<b>Miscellaneous equipment</b>	<b>87</b>	
Field Wiring Kit	87	
Blank Faceplates	87	
NT8D63AA	Overhead Cable Tray Kit	87
Earthquake Bracing Kit	88	
QRY551	Channel Service Unit	88
TELLABS 251	<b>24-Channel</b> Digital Echo <b>Cancellor</b>	88
BIX	Cross-Connect System	88
Northern Telecom	Publications	90

---

<b>List of terms</b>	<b>91</b>
----------------------	-----------

---

## General

---

The selection of a system option that best meets individual requirements is determined by the following factors:

- Number and type of terminal devices required
- Number and type of trunks required
- Traffic requirements for lines, trunks and consoles
- Special features required
- Growth forecast in terms of ports and features

Refer to *System engineering (553-3001-151)* and *Power engineering (553-3001-152)* to determine the proper system requirement.

### Equipment packages

There are various equipment packages available to provide basic systems. Information on these packages can be obtained from a Northern Telecom sales office.

### Conversion and expansion packages

In addition to the basic equipment packages, there are conversion and expansion packages available to upgrade existing systems. Contact a Northern Telecom sales office for details.

## **E q u i p m e n t   a v a i l a b i l i t y**

The equipment listed in this Northern Telecom Publication is available through Northern Telecom. Equipment may not be available in all market areas and may be discontinued at any time. Contact a Northern Telecom sales office for equipment availability.

## **S p e c i a l   f e a t u r e s**

Special features are purchased as options to the basic system. These features may consist of software or hardware only, or both. Those special features that include hardware (e.g., the Data Feature, Call Detail Recording, Caller's Name Display and Remote Peripheral Equipment) are described in separate Northern Telecom Publications which include ordering information.

## **P r o d u c t   c o d i n g**

With the application of Modular Documentation System (MDS) by Northern Telecom, the product code takes on a new form but does contain similar attributes as the apparatus system (QPC code). Figure 1-1 provides a comparison of the old and the new product codes.

The primary difference between the two systems is that the modular code is of a constant length (eighth characters) and the suffix is defined as family member. The "release number" and "series" are incremented as change is applied to the product.

Figure I-1  
 Modular and apparatus coding comparison

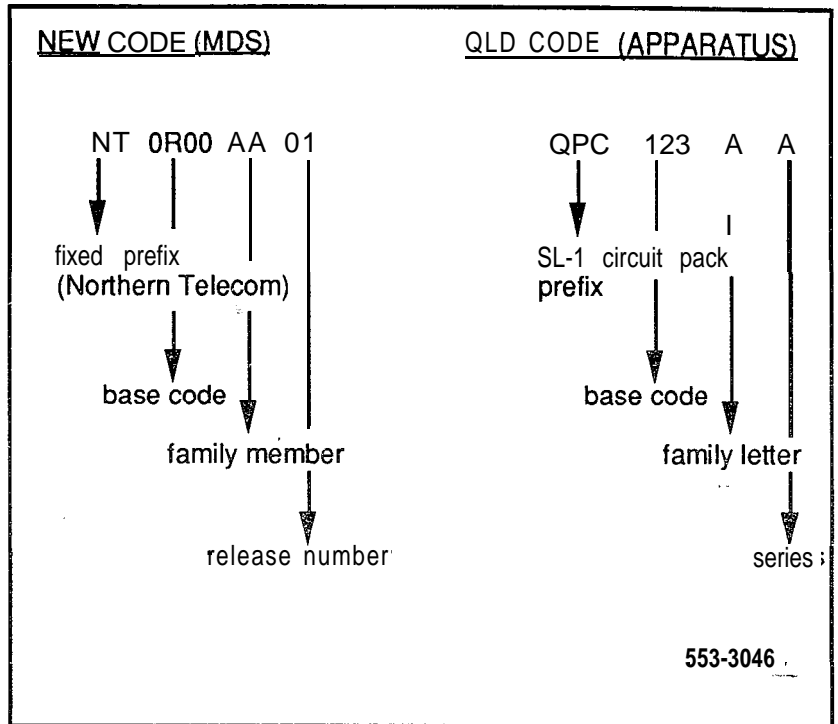



---

# Universal Equipment Modules and packaging

---

Universal Equipment Modules (**UEMs**) are self-contained equipment modules which house system components such as card cages, circuit cards, power units, mass storage units, and cabling.

Each UEM is approximately 80 cm (31.5 in.) wide, 52.1 cm (20.5 in.) deep (55.9 cm (22.0 in.) with covers), and 43.2 cm (17 in.) high. The weight of a UEM is approximately 21.8 kg (48 lbs) empty, including the top, bottom, sides, side trim panels, card cage, Input/Output (I/O) panel, and miscellaneous hardware.

All **UEMs** are equipped with a card cage assembly and a cover assembly. Refer to *Circuit puck installation and testing* (553-3001-211) for the identification and location of the different cards within each UEM.

A UEM that is populated with various hardware components is referred to as a module. The different types of modules available are described in this chapter.

Also described in **this** chapter are the main components of a system option which can be ordered as a separate package. These components are the Top Cap, the card cages, the pedestal, the Spacer Kit, and the Module Covers.

## **NT6D39AA, NT6D39DC CPU/Network Module**

**System hardware-System option 51/61**

**Purpose-**The **NT6D39** CPU/Network Module (hereafter referred to as **NT6D39** CPU/NET) houses a Central Processor Unit (CPU) and network cards.



This module is available in two versions:

- **NT6D39AA** for AC systems
- **NT6D39DC** for DC systems

The **NT6D39** CPU/NET card cage contains 18 card slots which support the following:

- network cards
- Clock Controller
- Serial Data Interface (**SDI**)/Enhanced Serial Data Interface (ESDI)
- Peripheral Signaling
- 3-Port Extender (3PE)
- mass storage unit
- CPU Function
- CPU Interface
- Changeover Memory Arbitrator (CMA)
- Memory
- D-Channel Handler Interface (**DCHI**)
- Primary Rate Interface (**PRI**)/Digital Trunk Interface (DTI)

The **NT6D39** CPU/NET Module is powered by a Common Equipment Power Supply.

Quantity-One per System option 51 system; two per System option 61 system

## **NT6D44AA, NT6D44DC Meridian Mail Module**

System hardware-System option 21/51/51/71

Purpose-The **NT6D44** Meridian Mail Module is a self-contained unit, complete with power converters and cooling units. It is designed to integrate with Meridian 1 Communication Systems but is also available as a stand-alone system.

This module is available in two versions:

— NT6D44AA for AC systems

— NT6D44DC for DC systems

The Meridian Mail Module is powered by two Common Equipment Power Supplies.

Refer to the Meridian Mail suite of documents (553-7041-xxx) for detailed information.

Quantity-Maximum of five per system

## **NT8D11 AC, NT8D11 DC CE/PE Module**

System hardware—System option 21 and 21A

**Purpose**—The NT8D11 Common/Peripheral Equipment Module (hereafter referred to as **NT8D11 CE/PE**) supports CPU, network, and Intelligent Peripheral Equipment (**IPE**) cards in a single module.

This module is available in two versions:

— NT8D11AC for AC systems

— NT8D11DC for DC systems

The **NT8D11 CE/PE** card cage contains 20 card slots which support the following:

— Floppy Disk Interface (**FDI**)/Floppy Disk Unit (**FDU**)

— CPU

— Memory

— **SDI/ESDI**

— network

— network/Digitone Receiver (**DTR**)

— **DCHI**

— **DTI/PRI**

— **IPE**

The NT8D11 CE/PE Module is powered by a Common/Peripheral Equipment (CE/PE) Power Supply.

Quantity-One per system

## NT8D13AA, NT8D13DC Peripheral Equipment Module

System hardware—System option 21/51/61/71

**Purpose**-The NT8D13 Peripheral Equipment Module (hereafter referred to as NT8D13 PE) supports the Dual Loop Buffer (DLB), and 10 card slots. The PE Buffer is situated near the center of the module, with five cards to the left and five cards to the right.

This module is available in two versions:

- NT8D13AA for AC systems
- NT8D13DC for DC systems

The NT8D13 PE Module is powered by a Peripheral Equipment Power Supply, and a Ringing Generator when 500/2500 sets are supported by the module.

Quantity-As required; refer to *System engineering* (553-3001-151)

## NT8D34AA, NT8D34DC CPU Module

System hardware-System option 71

**Purpose**-The NT8D34 CPU Module (hereafter referred to as NT8D34 CPU) houses the CPU, memory cards, and the mass storage.

This module is available in two versions:

- NT8D34AA for AC systems
- NT8D34DC for DC systems

The NT8D34 CPU card cage contains 15 card slots which support the following:

- Memory
- CMA

- CPU Interface
- CPU Function
- SDI/ESDI
- MSI
- Segmented Bus Extender (SBE)
- DCHI
- PRI/DTI
- Clock Controller
- Mass Storage Unit (MSU) or Floppy Disk Unit (FDU)

The NT8D34 CPU Module is powered by a Common Equipment Power Supply.

**Quantity-Two** per system

## **NT8D35AA, NT8D35DC Network Module**

**System hardware-System option 71**

**Purpose-The NT8D35 Network Module** (hereafter referred to as **NT8D35 NET**) provides the signal interface between the Common Equipment (CE) cards located in the module.

This module is available in two versions:

- **NT8D35AA** for AC systems
- **NT8D35DC** for DC systems

The **NT8D35 NET** card cage contains 15 card slots which support the following:

- 3PE
- Intergroup Switch (IGS) (for System option 71 only)
- peripheral signaling
- network cards
- **SDI/ESDI**

— PRI/DTI

The NT8D35 NET Module is powered by a Common Equipment Power Supply.

**Quantity-A** maximum of 10 per system (five network groups)

## NT8D36AA Inter Group Module

**System hardware--System option 71**

**Purpose-The** NT8D36AA Inter Group Module provides a path for the switching of traffic between the network groups in the system. Faceplate cables from the Clock Controller (CC) and Intergroup Switch (IGS) circuit cards are connected to the Inter Group Module. This module uses a QPC417 Junctor Board.

This module is used in both AC and DC systems.

**Quantity—One** per system

## NT8D37AA, NT8D37DC Intelligent PE Module

**System hardware-System option 21/51/61/71**

**Purpose-The** NT8D37 Intelligent Peripheral Equipment Module (hereafter referred to as NT8D37 IPE) supports a Controller card and 16 IPE cards. The Controller card is situated near the center of the module, between slot 7 and slot 8.

This module is available in two versions:

- NT8D37AA for AC systems
- NT8D37DC for DC systems

The card slots in the NT8D37 IPE card cage support the following:

- Universal Trunk
- E&M Trunk
- Digitone Receiver
- Analog Line card (ALC)

- Digital Line card (DLC)
- Analog Message Waiting Line card (MLC)

The **NT8D37 IPE** Module is powered by a Peripheral Equipment Power Supply, and a Ringing Generator when **500/2500** sets are supported by the module.

**Quantity**-As required; refer to *System* engineering (553-3001-151)

## **NT8D47AA, NT8D47DC Remote PE Module**

**System hardware**-System option 21/51/61/71

**Purpose**-The **NT8D47** Remote Peripheral Equipment Module (hereafter referred to as **NT8D47 RPE**) is an interface module used to extend the interconnection distance between local and remote sites.

The same module is used for **both** local and remote applications. **On** the local side, it interfaces to the QPC4 14 Network card for up to two network loops; on the remote side, it supports the **NT8D13** PE Module.

This module is available in two versions:

- **NT8D47AA** for AC systems
- **NT8D47DC** for DC systems

The **NT8D47** RPE card cage contains 12 card slots which support the following:

- 1.5 Mb converter
- 2 Mb converter
- carrier interface
- remote peripheral
- local carrier buffer
- carrier interface
- 2 Mb converter
- 1.5 Mb converter
- carrier maintenance

- PRI/DTI (optional)

The **NT8D47 RPE** Module is powered by a Common Equipment/Peripheral Equipment Power Supply.

Quantity-Since each **NT8D47 RPE** Module serves two network loops, the number of modules required per system depends on the number of stations in the remote site.

## **NT8D49 Spacer Kit**

### **System Hardware-All**

Purpose-Bolts modules together for side-by-side expansion. The Spacer Kit includes:

- expansion spacer
- RF gasketing
- eight bushings

## **NT8D55AA Universal Equipment Module cover**

### **System Hardware-All**

Purpose-This is the front or rear cover that is part of the UEM. Two covers are required for each UEM.

## **Universal Equipment Module side panel**

### **System Hardware-All**

Purpose-This is the side panel (P0699724) that is part of the UEM. A maximum of eight panels are required for multi-column systems.

## **Card cage assemblies**

A card cage assembly consists of a sheet metal case and an associated backplane. The card cage provides the physical framework that houses the circuitry and power supplies within the UEM.

The following is a list of all the card cage assemblies available and their corresponding UEMs:

- NT6D3903      NT6D39AA/DC CPU/Network Module
- NT8D1103      NT8D1 1AC/DC Common/Peripheral Equipment Module
- NT8D1303      NT8D13AA/DC Peripheral Equipment Module
- NT8D3403      NT8D34AA/DC CPU Module
- NT8D3503      NT8D35AA/DC Network Module
- NT8D3703      NT8D37AA/DC Intelligent Peripheral Equipment Module
- NT8D4703      NT8D47AA/DC Remote Peripheral Equipment Module

## Top Cap

### System Hardware-All

**Purpose-**The top cap is mounted on the highest module of each column. The top cap is approximately 80 cm (31.5 in.) wide by 55.9 cm (22 in.) deep by 7.6 cm (3 in.) high and weighs 3.6 kg (8 lbs). It consists of a front and a rear air exhaust grill and thermal sensors. System option 21A contains a small fan to cool the power supply.

Three versions of the top cap are available:

- NT7D00AA      AC systems
- NT7D00BA      DC systems
- NT7D00AC      System option 21A only

## Pedestal

### System Hardware-All

**Purpose-**The Pedestal is a base unit made of die-cast construction. It is approximately 80 cm (31.5 in.) wide by 64.8 cm (25.5 in.) deep by 25.4 cm (10 in.) high and weighs 13.6 kg (30 lbs) empty. Leveling feet are provided for up to four tiers, while a caster option is provided for up to two tiers.

The pedestal is available in three versions:

- NT8D27AB      for AC systems



- NT8D27AC for System **option 21A** only
- NT7D09AA for DC systems

The pedestal for AC and DC systems (except System option 21A) can house any of the following field replaceable assemblies:

- Power Distribution Unit NT8D53AB or NT7D10AA
- Blower Unit NT8D52AA or NT8D52DC
- Fan Unit NT7D17AC or NT7D17DC
- Leveling foot A03 18207
- Air grill (molded) PO699797
- Air filter PO699798

The pedestal for System option 21A is basically the same as the one used for other system options except it can only house the following field replaceable assemblies:

- Power Distribution Unit NT8D53AD
- Leveling foot A03 18207
- Air grill (molded) PO699797

---

## Power and cooling equipment

---

### A0367754 Top Cap Fan

System Hardware-System option 21A

**Purpose-**The A0367754 Top Cap Fan is located in the Fan and Sensor Panel. It provides cooling for the NT7D14AA CE/PE power Supply AC. There is no speed or temperature control provided with it. Power to the Top Cap Fan is controlled by the circuit breaker located on the back panel of the pedestal.

Quantity-One per system

### NT5C03BJ Switched Mode Rectifier -48V/50A

System Hardware-System option 71 (DC version)

**Purpose-Solid** state, switched-mode rectifier. Converts 208/240 VAC (nominal) to -48 VDC (nominal), with a 50A output. Used in the QCA13 power plant, with up to ten rectifiers in parallel.

Quantity-As required by system power consumption

### NT6D40AA Peripheral Equipment Power Supply DC

System Hardware-All

**Purpose-The** Peripheral Equipment Power Supply DC is used to provide power to all peripheral equipment modules in DC systems. It converts -48V DC to +5V, +8.5V, ±10V, ±15V, and -48V DC voltages used to power peripheral equipment logic cards and to supply talk battery to lines and trunks. This power supply is located in the far left hand card slot labeled "PE Pwr Sup".

**Quantity**—One Peripheral Equipment Power Supply DC is used in each of the following DC modules:

- Intelligent Peripheral Equipment Module (NT8D37DC)
- Peripheral Equipment Module (NT8D13DC)

## NT6D41AA Common Equipment Power Supply DC

### System Hardware-All

**Purpose**—The Common Equipment Power Supply DC is used in the common equipment modules in DC systems. It is located in the first slot on the left in the module labeled “CE Pwr Sup”. It converts -48V DC to +5V and  $\pm 12$  V DC to provide all required voltages for CE and network circuit cards.

**Quantity**—One Common Equipment Power Supply DC is used in each of the following DC modules:

- CPU Module (NT8D34DC)
- Network Module (NT8D35DC)
- CPU/Network Module (NT6D39DC)

Two Common Equipment Power Supply DC is used in the Meridian Mail Module (NT6D44DC).

## NT6D52AA Switched Mode Rectifier -48V/30A

### System Hardware-System option 21/51/61 (DC versions)

**Purpose**—The Switched-Mode Rectifier is a QRF12 rectifier shielded to limit electromagnetic interference. It converts 208/240 VAC (nominal) to -48 VDC (nominal), with a 30A output. It connects to the system through the QBL15 Battery Distribution Box.

**Quantity**—Generally one rectifier per every two fully loaded modules. Exact quantity depends on system configuration and power requirements.

---

## NT6D53AA Junction Box

System Hardware-All (DC version)

**Purpose**-The Junction Box is **required** when the distance from the rectifier to the pedestal is over 0.74 m (8 ft), which requires wire larger than 10 AWG. It provides a set of connection terminals for the 4-AWG wire that comes from **the** rectifier, and a set of connection terminals for the **10-AWG** wire that goes into the pedestal.

Refer to *Power* engineering (553-3001-152) for more information.

**Quantity**—One per DC pedestal

## NT6D5303 Logic Return Equalizer

System Hardware-System option 71 (DC version)

**Purpose**-The Logic Return Equalizer (**LRE**) mounts on top of the QCA13 cabinet. It is used as the single point ground for System option 7 1.

Quantity--One per system

## NT7D0003 Fan and Sensor Panel

System Hardware-System option 21A

**Purpose**-The **NT7D0003** Fan and Sensor Panel contains a 230 VAC tubeaxial fan (A0367754) and a thermal sensor for a high temperature/shutdown alarm to the option 21A System Monitor. The fan provides cooling for the **NT7D14AA** Common/Peripheral Equipment Power Supply. It is on **continously** and receives power directly **from** the Power distribution Unit via the module power harness.

The **NT7D0003** Fan and Sensor Panel consists of the following:

- a perforated top shield (**P0703062**)
- a Top Cap Fan (A0367754)
- a fan power harness (**NT7D0004**)
- a thermostat harness (**NT8D46AC**)

**Quantity**—One per system

## NT7D03AA Ringing Generator DC

### System Hardware-All

**Purpose-**The Ringing Generator DC operates from a nominal **-48V** DC input and provides selectable AC ringing voltage outputs superimposed on **-48 VDC**. The frequency and voltage options are **20/25/50** Hi and **70/80/86** VAC. It also supplies **-150V** DC Message Waiting lamp **500/2500** set applications. The Ringing Generator DC mounts in the PE modules to the right of the Peripheral Equipment Power Supply DC.

**Quantity**—One Ringing Generator DC is used in each of the following, when these DC modules support **500-** or **2500-type** analog sets:

- Intelligent Peripheral Equipment Module (NT8D37DC)
- Peripheral Equipment Module (NT8D13DC)

## NT7D04AA CE/PE Power Supply DC

### System Hardware-All (DC versions)

**Purpose-**The Common/Peripheral Equipment Power Supply DC converts **-48V** DC to **+5V, +8.5V, ±15V, ±12V, -48V**, and **-150V** DC voltages used to power peripheral and common equipment, supply talk battery, and light Message Waiting lamps on **500/2500** sets. It provides selectable AC ringing voltage outputs superimposed on **-48 VDC**. The frequency and voltage options are **20/25/50** Hz and **70/80/86** VAC. It is located to the left of the module, in the slot labeled “**CE/PE Pwr Sup**”.

**Quantity-**One Common/Peripheral Equipment Power Supply DC is used in each of the following DC Modules:

- Common/Peripheral Equipment Module (NT8D 11DC )
- Remote Peripheral Equipment Module (NT8D47DC)

## NT7D10AA Power Distribution Unit DC

### System Hardware-All

**Purpose-**The **NT7D10AA** Power Distribution Unit DC distributes power to the entire column. It is located in **the** rear of the pedestal. It houses five circuit breakers (one for each Module and one for the Blower Unit) and the System Monitor.

**Quantity-One** p&pedestal/column in DC systems

## NT7D12AA Rectifier Rack

**System Hardware**—21/51/61 (DC versions)

**Purpose**—This is a 48.3-cm (19-in.) open relay rack which is approximately 1.5 m (5 ft) high. It supports up to three NT6D52AA Rectifiers in a single column.

**Quantity**—One rack per every three NT6D52AA Rectifiers, up to a maximum of three racks per system

## NT7D14AA CE/PE Power Supply AC

**System Hardware**—All

**Purpose**—The Common/Peripheral Equipment Power Supply AC converts 208/240V AC to +5V, +8.5V, ±15V, ±12V, -48V, and -150V DC voltages used to power peripheral and common equipment, supply talk battery, and light Message Waiting lamps on 500/2500 sets. It provides selectable AC ringing voltage outputs superimposed on -48 VDC. The frequency and voltage options are 20/25/50 Hz and 70/80/86 VAC. It is located to the left of the module, in the slot labeled “CE/PE Pwr Sup”.

**Quantity**—One Common/Peripheral Equipment Power Supply AC is used in each of the following AC modules:

- Common/Peripheral Equipment Module (NT8D1 1AC)
- Remote Peripheral Equipment Module (NT8D47AA)

## NT7D15AA System Monitor - System option 21A

**System Hardware**—System option 21A

**Purpose**—The NT7D15AA System Monitor - System option 21A provides an interface to communicate and monitor the NT7D14AA CE/PE Power Supply AC, the CPU, and the thermal switches. In the event of failure, the System Monitor - System option 21A is notified and the appropriate alarm is set. A system alarm LED located below the top cap lights to indicate CPU failure.

**Quantity**—One per system

## **NT7D17AC Fan Unit AC**

**System Hardware-**System option 21 with up to two tiers

**Purpose-**The NT7D17AC Fan Unit AC is housed within the pedestal and provides cooling for the entire column. It consists of three fans and a circuit breaker located in the front.

**Quantity-**One per pedestal

## **NT7D17DC Fan Unit DC**

**System Hardware-**System option 21 with up to two tiers

**Purpose-**The NT7D17DC Fan Unit DC is the same as the NT7D17AC Fan Unit AC except that it is used for DC systems. It has an on/off switch in the front and its own separate circuit breaker located on the Power Distribution Unit.

**Quantity--**One per pedestal

## **NT7D1201 Rectifier Baffle/Mounting Kit**

**System Hardware-**System option 21/51/61 (DC versions)

**Purpose-**The Rectifier Baffle/Mounting Kit consists of a set of support brackets for mounting the NT6D52AA Rectifier to an NT7D12AA Rack, and a heat baffle plate. The baffle directs exhaust air from the lower rectifier away from the inlet to the upper rectifier, thereby allowing cooling by natural convection.

**Quantity-**One per NT6D52AA Rectifier

## **NT8D06AA Peripheral Equipment Power Supply AC**

**System Hardware-**All

**Purpose-**The Peripheral Equipment Power Supply AC is used to provide power to all peripheral equipment modules in AC systems. It converts 208/240V AC to +5V, +8.5V,  $\pm 10V$ ,  $\pm 15V$ , and -48V DC voltages used to power peripheral equipment logic cards and to supply talk battery to lines and trunks. This power supply is located in the far left-hand card slot labeled "PE Pwr Sup".

**Quantity--One** Peripheral Equipment Power Supply AC is used in each of the following AC modules:

- Intelligent Peripheral Equipment Module (NT8D37AA)
- Peripheral Equipment Module (NT8D13AA)

## **NT8D21AA Ringing Generator AC**

### **System Hardware-All**

**Purpose-The** Ringing Generator AC operates from a nominal 208/240 VAC input and provides selectable AC ringing voltage outputs superimposed on -48 VDC. The frequency and voltage options are 20/25/50 Hz and 70/80/86 VAC. It also supplies -150V DC Message Waiting lamp 500/2500 set applications. The Ringing Generator AC mounts in the PE modules to the right of the Peripheral Equipment Power Supply.

**Quantity-One** Ringing Generator AC is used in each of the following, when these AC Modules support 500- or 2500-type analog sets:

- Intelligent Peripheral Equipment Module (NT8D37AA)
- Peripheral Equipment Module (NT8D13AA)

## **NT8D22AB System Monitor**

### **System Hardware-All** except System option 21A

**Purpose-The** NT8D22AB System Monitor monitors the status of **all** internal power and cooling related components, as well as external DC rectifiers, batteries, and **Uninterruptable** Power Supplies (UPS). The System Monitor is mounted in the Power Distribution Unit, within the Pedestal.

The System Monitor that handles the communication with the system CPU (via SDI port) is the master; all others function as slaves. There is a serial communication link between the master and **the** slave System Monitors. In addition to CPU status reporting, the System Monitor also controls all external visual status indications.

**Quantity-One** master and up to 63 slave System Monitors are allowed per system.



## NT8D29AA Common Equipment Power Supply AC

**System Hardware--System** option 51/61/71

**Purpose-The** Common Equipment Power Supply AC is used in the common equipment modules in AC systems. It is located in the first slot on the left in the module labeled "CE Pwr Sup". It converts 208/240V AC to +5V and  $\pm 12$  V DC to provide all required voltages for CE and network circuit cards.

**Quantity-One** Common Equipment Power Supply AC is used in each of the following AC Modules:

- CPU Module (NT8D34AA)
- Network Module (NT8D35AA)
- CPU/Network Module (NT6D39AA)

Two Common Equipment Power Supply AC is used in the Meridian Mail Module (NT6D44AC).

## NT8D39AA Power Failure Transfer Unit

**System Hardware-All**

**Purpose-Provides** an interface between CO lines, Private Branch Exchange (PBX), and 500/2500 phones (rotary dial and pushbutton). The Power Failure Transfer Unit allows eight phones to be connected to the CO lines in the event of a PBX power failure or malfunction. The Power Fail Transfer Unit is invisible to the switch and CO lines during normal PBX operations.

The Power Fail Transfer Unit is approximately 22.8 cm (9 in) long by 22.8 cm (9 in) wide by 8.8 cm (3.5 in) deep. It is screw-mounted to the Distribution Frame and connects to the Main Distribution Frame and switch by two 25-pair cables.

**Note:** The Power Fail Transfer Unit is not recommended for use in international applications.

**Quantity-One** per system

## NT8D52AA Blower Unit

### System Hardware-All

**Purpose-**The Blower Unit is part of the system cooling assembly and provides forced-convection cooling. Housed within the pedestal, it contains two backward-curved impellers (rotor blades) which are cylindrically shaped, approximately 22.8 cm (**9.in**) in diameter, and 6.9 cm (2.75 in) thick. A circuit breaker is located on **the** front of the blower chassis to turn the unit on and off. Each unit weighs about 1.5 kg (3.5 lbs).

The unit communicates **with** the power distribution section by engaging a connector in the rear of the pedestal.

**Quantity-**One per pedestal in AC systems

## NT8D52DC Blower Unit

### System Hardware-All

**Purpose—**This Blower Unit is the same as the **NT8D52AA** Blower Unit except that it is used for DC systems. It has its own separate circuit breaker located on the Power Distribution Unit. Also, for maintainability in the field, a switch is located on the front of **the** blower chassis to turn the unit on and off.

**Quantity-**One per pedestal in DC systems

## NT8D53AB Power Distribution Unit AC

### System Hardware-All

**Purpose-**The Power Distribution Unit AC distributes power to the entire column. It is located in **the** rear of the pedestal. It houses a main circuit breaker and the System Monitor.

**Quantity-**One per pedestal/column in AC systems

## **NT8D53AD Power Distribution Unit - System option 21A**

**System Hardware-System** option 21A

**Purpose**—The Power Distribution Unit - System option 21A is a panel located in the pedestal. It contains a circuit breaker, a terminal block, and an EM1 filter. The power cable enters the pedestal and connects to the circuit breaker. From the circuit breaker, the AC voltage goes to the terminal block through the EM1 filter and back to the terminal block where it is distributed to the NT7D 14AA CE/PE Power Supply AC and the fan located in the top cap.

**Quantity**—One per system

## **NT8D56AA Module Power Distribution Unit**

**System Hardware-All**

**Purpose**—The NT8D56AA Module Power Distribution Unit protects the power supply and distributes power within a module. It houses a single breaker and is used in conjunction with the NT8D29AA CE Power Supply AC.

**Quantity**—One per NT8D35AA NET, NT6D39AA CPU/NET, or NT8D34AA CPU Module

## **NT8D56AB Module Power Distribution Unit**

**System Hardware-All**

**Purpose**—The NT8D56AB Module Power Distribution Unit protects the power supply and distributes power within a module. It houses a single breaker and is used in conjunction with the NT7D14AA CE/PE Power Supply AIC.

**Quantity**—One per NT8D47AA RPE Module

## **NT8D57AA Module Power Distribution Unit**

**System Hardware-All**

**Purpose**—The NT8D57AA Module Power Distribution Unit protects the power supply and distributes power within a module. It houses a dual

breaker and is **used in** conjunction with the **NT8D06AA** PE Power Supply AC and the **NT8D21AA** Ringing Generator AC.

Quantity-One per **NT8D13AA** PE or **NT8D37AA** IPE Module

## **NT8D62AA, NT8D62DC Temperature Sensor Panel**

**System Hardware**-AN except System option 21A

**Purpose**-The **NT8D62** Temperature Sensor Panel communicates with the System Monitor in the event of overheating. It contains hvo temperature sensors which protect against **thermal** damage by detecting extreme temperature.

The Temperature Sensor Panel is available in two versions:

- **NT8D62AA** for AC systems
- **NT8D62DC** for DC systems

The Temperature Sensor Panel consists of the following:

- a perforated shield panel (**P0703062**)
- an LED bracket (**P0703061**)
- a thermostat harness (**NT8D46AC**)
- an air probe harness (**NT8D46AM** or **NT8D46DC**)
- an air probe connector bracket (**P0703064** or **P0708 186**)

Quantity-One per top cap

## **QBL12 Battery Distribution Box**

**System Hardware**-All (DC versions)

**Purpose**—**Connects** customer-provided power supplies to the system. Allows connection of up to 24 modules.

Quantity-One per system

## **QBL15 Power/Battery Distribution Box.**

**System Hardware-System** option 21/51/61 (DC versions)

**Purpose**—Allows the parallel connection of up to three **NT6D52AA** Rectifiers, for connection to the system and to reserve batteries. Includes main fuses, diode blocking, test points, QPC188 battery monitor card, and sense lead fusing on connections from each rectifier.

**Quantity**—One per every three **NT6D52AA** Rectifiers, up to a maximum of two **QBL15s** per system

## **QCA13 DC Power Plant**

**System Hardware-System** option 71 (DC version)

**Purpose**—Consists of a primary power cabinet with fusing and distribution hardware, monitoring and control, and up to four **NT5C03** 50A Rectifiers. Up to two supplemental cabinets can be added, with up to four **rectifiers** in the first supplemental cabinet and up to two rectifiers in the second cabinet, for a total of 10 rectifiers and a total system capacity of 500A. (This power system is also referred to as the J2412 power plant; QCA13 is actually the cabinet designation, but is the more commonly used name.)

**Quantity**—As required by system power consumption

## **QPC188 Battery Monitor**

**System Hardware**—All

**Purpose**—Located in each Battery Distribution Box to monitor rectifier and battery voltages. Generates low float alarm, low voltage trip alarm and sense lead fuse conditions.

**Quantity**—One circuit card in **QBL12** or **QBL15**

## QRF12 -52 V Rectifier

System Hardware--System option 21/51/61 (DC version)

**Purpose**—Converts 115 V AC and 220 V AC to -52 V DC (nominal).

**QRF12B** voltage conversions from 90V to 129V, and 190V to 250V.

Connects to the columns through the **QBL15** Power/Battery Distribution Box.

Quantity—One for every two modules



---

## Common Equipment cards

---

### **NT8D04AA Super-loop Network**

#### **System Hardware-All**

**Purpose-** Provides 120 time slots (one superloop) interface between Network and Intelligent Peripheral Equipment. Utilizes the equivalence of four network loops. May be connected to one or two **NT8D01** Controller card(s).

The Superloop Network card is equipped with a Motorola **68000-type** microprocessor which performs network diagnostics and signaling control, and communicates with the Intelligent Peripheral Controller.

**Quantity-**As required. Refer to *System* engineering (553-3001-151) for engineering details.

### **NT8D17AA Conference/line and Digit Switch (TDS)**

#### **System Hardware—All**

**Purpose-**Provides both Conference and TDS functions. This card accesses two network loops, one for each function.

The Conference circuitry has a warning tone option and supports broadcast mode. Up to 15 simultaneous conferences can be controlled with the restriction that the total number of conferees in all conferences is not greater than 30.

The TDS circuitry provides tones for different countries (up to 256 tones and cadences).



Quantity—As required. **Refer** to *System* engineering (553-3001-151) for engineering details.

## **NT8D18AA Network/Digitone Receiver**

**System Hardware-System** option 21 and 21A

**Purpose**—Combines the functionality of the Network Controller and **Digitone** Receiver cards in a **mother/daughterboard** assembly. The motherboard plugs into a dedicated slot on the backplane. The daughterboard attaches to the motherboard through an **SDI/ESDI** connector and does not connect to the backplane.

**Quantity**—One per NT8D11 CE/PE Module

## **NT8D19AA Memory/Peripheral Signaling**

**System Hardware-System** option 21 and 21A

**Purpose**—Combines the functionality of the Memory and Peripheral Signaling cards, as well as miscellaneous CPU functions.

The CPU functions include interrupt and fault monitoring.

The Peripheral Signaling function provides:

- signaling interface between CPU and Peripheral Equipment for up to 32 network loops
- clock and timing signals for real-time transmission functions

**Quantity**—One per NT8D11 CE/PE Module

## **NT8D41AA Serial Data Interface paddle board (Dual Port)**

**System Hardware-System** option 21/51/61

**Purpose**—Provides two serial ports between the SL-1 processor and an external device. Each port supports

- RS-232-C interface
- **8-bit** ASCII data with parity and stop bit
- asynchronous, start-stop operation

- data rates of 300, 600, 1200, 2400, 4800, and 9600 baud
- Data Terminal Equipment (DTE) mode
- Data Communication Equipment (DCE) mode

**Quantity-Three** maximum per NT8D11 CE/PE Module; two maximum per NT6D39 CPU/NET Module

## NT8D68AA Floppy Disk Unit

System **hardware**—System option 21/51/61/71

**Purpose**--The Floppy Disk Unit (FDU) is used to load the programs and office data into the system memory. The FDU contains two **3.5-inch** floppy drives and is controlled by the QPC742 Floppy Disk Interface (FDI). Each floppy drive has a formatted capacity of 1.44 MB.

The FDU occupies two adjacent card slots in the CPU, Network, or PE Module. It is powered through the cable connecting it to the FDI. The FDU can be connected to one or two FDI's as required by the system.

Quantity-One per system

## NT8D69AA Multi Disk Unit

System **hardware**-System option 51/61/71

**Purpose**-The Multi Disk Unit (MDU) is used to load the programs and office data into the system memory. The MDU contains the following:

- two 3.5-inch floppy drives which are connected to the SCSI interface through the SCSI/floppy controller; each drive has a formatted capacity of 1.44 MB
- a **3.5-inch** hard disk drive which has a built-in SCSI interface and a capacity of 20 MB
- an SCSI/floppy controller

The MDU occupies three adjacent card slots in the CPU, CPU/NET, or Network Module and requires **5V** and 12V from the module. The MDU is controlled by the QPC584 Mass Storage Interface (MSI). The MDU can be connected to one or two **MSIs** as needed.

**Quantity—One per system**

## **QMM42 Security Data Cartridge**

**System Hardware—All**

**Purpose—**This is a security measure that allows a customer access only to software packages purchased for his system. This security data cartridge is mounted on either the **QPC584** Mass Storage Interface or **QPC742** Floppy Disk Interface card.

**Quantity—One per MSI/FDI card**

## **QPC43 Peripheral Signaling**

**System Hardware—System option 51/61/71**

**Purpose—Provides** a signaling interface between the CPU and PE via the Network cards. Provides basic bit rate 2.048 MHz clock and timing signals for real-time functions.

**Quantity—One per NT8D35 NET or NT6D39 CPU/NET Module**

## **QPC215 Segmented Bus Extender**

**System Hardware—System option 71**

**Purpose—The** Segmented Bus Extender (SBE) extends CPU bus signals (address, data, and control) to the Network Module. It also allows recovery of calls by isolating bus faults to a single network group.

Note: **QPC215C** or later vintage is required.

**Quantity—One** circuit card in each CPU per network group, with a maximum of five per CPU

## **QPC412 Intergroup Switch**

**System Hardware—System option 71**

**Purpose—Provides** space switching between network groups in multigroup systems.

**Quantity-Two** per Network Module (use vintage C when two or more groups are installed)

## QPC414 Network

### System Hardware-All

**Purpose—Provides** 30 time slots interface per each of two network loops. Provides speech path switching, signaling and control circuits for two network loops. Interfaces between network and **NT8D13** PE, **NT8D47** RPE, and Meridian Mail Modules, and **PRI/DTI** cards,

**Quantity-As** required; refer to *System engineering (553-3001-151)*

## QPC417 Junctor Board

System Hardware-System option 71

**Purpose-Provides** space switching paths between network groups in multigroup systems for up to five groups.

**Quantity-One** per system

## QPC441 Three-Port Extender

System Hardware-System option 61/71

**Purpose-Extends** CPU data, address and control signals between one **NT8D35** NET Module and a **QPC215** Segmented Bus Extender on a CPU Module in System option 71. In System option **61**, interfaces between two **NT6D39** CPU/NET Modules.

**Quantity-One** per **NT8D35** NET or **NT6D39** CPU/NET Module

## QPC471 Clock Controller

### System Hardware-All

**Purpose-The** Clock Controller (CC) is used in System option 71 to synchronize the Meridian 1 network to an external source clock and to generate and distribute clock to the Meridian 1 system. It is also used with **PRA/DTI** in all system options.

*Note:* **QPC471C** or later vintage is required.

**Quantity-Two** for System option 71, and one per CPU when DTI or **PRA** is required in other options.

## QPC477 Bus Terminating Unit

**System Hardware-System** option 51/61/71

Purpose-Bus Terminating Units (**BTUs**) are installed in the CE Modules. They provide a logical termination to the CPU and network buses. They are paddle boards installed in dedicated slots, between circuit cards from the front of the module.

**Quantity-The** following vintages are required for the modules listed:

- **QPC477-A9**  
One required for each **NT6D39 CPU/NET** and each **NT8D35 NET**
- **QPC477-A10**  
One required for each **NT6D39 CPU/NET** and each **NT8D35 NET**
- **QPC477-A20**  
One required for each **NT8D34 CPU**
- **QPC477-A21**  
One required for each **NT8D34 CPU**
- **QPC477-A22**  
One required for each **NT6D39 CPU/NET**

## QPC513 Enhanced Serial Data Interface

**System Hardware-All**

Purpose-Provides two serial data interface circuits that can be configured for either synchronous or asynchronous data communications at rates of up to 64 kbps (synchronous) or 19.2 kbps (asynchronous).

**Note:** Use **QPC5 13D** with Meridian Mail option and other applications requiring Integrated Services Digital Network (**ISDN**) Application Protocol.

**Quantity-As** required per application

---

## QPC579 CPU Function

System Hardware-System option 51/61/71

**Purpose**—The CPU Function card works in conjunction with the CPU Interface card (QPC580). It contains the main CPU logic circuitry. The CPU provides a 24-bit data bus. The CPU Function card contains a QPC939 system ROM.

Quantity-One per CPU Module

## QPC580 CPU Interface

System Hardware-System option 51/61/71

**Purpose**-Contains the logic required to interface the CPU with the external address bus and detects, identifies and isolates bus faults. Works in conjunction with QPC579 CPU Function card.

Quantity-One per CPU Module

## QPC581 Changeover and Memory Arbitrator

System Hardware-System option 51/61/71

**Purpose**-The Changeover and Memory Arbitrator (CMA) card controls CPU access to the duplicated memory in dual CPU systems, automatically disables faulty memory cards and controls CPU changeover. The CMA switches from one CPU to the other in the event of a CPU fault.

Quantity-Two CMA cards are required per system (one per CPU/Memory configuration).

## QPC583 Memory

System Hardware-System option 51/61/71

**Purpose**-Provides 768K of Random Access Memory (RAM).

Quantity-One per CPU for System option 51/61; two maximum per System option 71

## QPC584 Mass Storage Interface

System Hardware-System option 51/61/71

**Purpose-Interface** between the Multi Disk Unit (**MDU**) and CPU(s). Provides address matching, disk drive control, data buffering and interrupt control circuits.

The **MSI** is used with the MDU and contains:

- two high capacity floppy disk drives or
- one Winchester disk drive with two high capacity floppy drives as backup

Note: **QPC584D** or later vintage is required.

**Quantity-One** MSI circuit card for each CPU/MDU.

## QPC687 CPU with SDI/RTC

System Hardware-System option 21 and 21A

**Purpose**—This is a stand-alone CPU card with error correction, real-time clock, and one **SDI** port

Note: **QPC687B** or later vintage is required.

**Quantity-One** per system

## QPC720 Primary Rate Interface

System Hardware-All

**Purpose-The** ISDN Primary Rate Interface (**PRI**) card allows twenty **three** 64 Kbps clear channel operation with a single 64 Kbps common signaling channel. It is used in conjunction **with** DCHI to provide PRA. The PRI circuit card provides the physical DS-1 interface and is also used for DTI applications.

**Quantity-One** per Primary Rate Access (**PRA**) or DTI link

## QPC742 Floppy Disk Interface

### System Hardware-All

**Purpose—Interface** between the **Floppy** Disk Unit (**FDU**) and one CPU. Provides address matching, disk drive control, data buffering and interrupt control circuits.

**Quantity—One** per CPU

## QPC757 D-Channel Handler Interface

### System Hardware-All

**Purpose—The** D-Channel Handler Interface (**DCHI**) card processes the LAPD protocol for ISDN primary rate signaling channel and ISDN Signaling Link (ISL). It also provides a single asynchronous Serial Data Interface (SDI) port.

**Quantity—One** per 16 PRI links to the same location (eight maximum per system)

## QPC841 Four-Port Serial Data Interface

### System Hardware-All

**Purpose—Provides** four serial ports between the system processor and an external device. Each port supports

- RS-232-C interface
- 8-bit ASCII data with parity and stop bit
- asynchronous, start-stop operation
- data rates of **300, 600, 1200, 2400, 4800,** and 9600 baud
- Data Terminal Equipment (DTE) mode
- Data Communication Equipment (DCE) mode

**Quantity—Up** to four per system



## QPC939 Read-Only Memory

System Hardware-System option 5 1/61/71

Purpose-Read-Only Memory (ROM) daughterboard on the QPC579 CPU Function card.

Quantity-One per CPU

## QPC940 Read-Only Memory

System Hardware-System option 21

Purpose-ROM daughterboard on the QPC687 CPU with SDI/RTC card.

Quantity-One per CPU

---

## Peripheral Equipment cards

---

### NT8D01 AD Controller-2

#### System Hardware-All

**Purpose-Provides** a primary interface and control function between the Superloop Network card and the IPE Module over up to two **10.24Mbs** superloops. Each Controller-2 card serves up to 16 IPE cards.

The Controller-2 card interfaces with up to two **NT8D04AA** Superloop Network cards. It is equipped with a Motorola **68000-type** microprocessor which performs some local call processing and maintenance diagnostics, thus off-loading the system CPU.

**Quantity-One** per **NT8D37 IPE Module**

### NT8D01 AC Controller-4

#### System Hardware-All

**Purpose-Provides** a primary interface and control function between the Superloop Network card and the IPE Module over up to four **10.24Mbs** superloops. Each Controller-4 card serves up to 16 IPE cards.

The Controller-4 card interfaces with up to four **NT8D04AA** Superloop Network cards. It is equipped with a Motorola **68000-type** microprocessor which performs some local call processing and maintenance diagnostics, thus off-loading the system CPU.

**Quantity-One** per **NT8D37 IPE Module**

## NT8D02AA Digital Line card

### System Hardware-All

**Purpose—Provides** interface to up to 16 digital integrated voice and data sets for a total of 32 ports. It is equipped with an Intel **8051-type** microprocessor which performs several functions; some of which are as follows:

- control of card operation
- card identification
- self-test
- status reporting to the Controller
- maintenance diagnostics

Quantity-Up to sixteen cards per NT8D37 IPE Module

## NT8D03AB Analog Line card

### System Hardware-All

**Purpose-Provides** interface to up to 16 analog sets (500/2500). It is equipped with an Intel **8051-type** microprocessor which performs several functions, some of which are as follows:

- control of card operation
- card identification
- self-test
- status reporting to the Controller
- maintenance diagnostics

Quantity-Up to sixteen cards per NT8D37 IPE Module

## NT8D09AB Analog Message Waiting Line card

### System Hardware—All

**Purpose-Provides** interface to up to 16 analog sets (500/2500) with Message Waiting lamp feature. It is equipped with an Intel 8051-type

microprocessor which performs several functions, some of which are as follows:

- control of card operation
- card identification
- self-test
- status reporting to the Controller
- maintenance diagnostics

**Quantity-Up** to sixteen cards per NT8D37 IPE Module

## **NT8D14AA Universal Trunk**

### **System Hardware-All**

**Purpose-Provides interface** connecting the trunk facility to the NT8D37 IPE Module. It is equipped with an Intel 8052-type microprocessor which performs several functions, some of which are as follows:

- control of card operation
- card identification
- self-test
- status reporting to the Controller
- maintenance diagnostics

This card interfaces eight 600 or 900  $\Omega$  trunks with the system in A-Law or  $\mu$ -Law application. Each of these eight ports can be individually configured to operate as:

- Central Office (CO) trunk
- Direct Inward Dialing (DID) trunk
- 2-way Tie, Dial Repeating (2DR)
- 2-way Tie, Outgoing Automatic Incoming Dial (OAID) trunk
- Outgoing Automatic Number Identification (OANI) trunk
- Recorded Announcement (RAN) trunk
- Music trunk

— Paging trunk

The Universal Trunk card is software selectable and complies with CSA Standard C82.2 No. 0.7 - M1985 and **EIA** Standard 464A.

**Quantity-Up to sixteen cards per NT8D37 IPE Module**

## **NT8D15AA E&M Trunk**

### **System Hardware-All**

Purpose-Used in both A-Law and  **$\mu$ -Law** applications. Provides interface connecting the trunk facility to the **NT8D37 IPE** Module. It is equipped with an Intel **8052-type** microprocessor which performs several functions, some of which are as follows:

- control of card operation
- card identification
- self-test
- status reporting to the Controller
- maintenance diagnostics

The E&M Trunk provides four analog trunks, each of which can be individually configured to operate as:

- E&M signaling trunk
- two-wire Tie trunk
- four-wire Tie trunk
- Paging trunk

The E&M Trunk card is software selectable and complies with CSA Standard C82.2 No. 0.7 • M1985 and EIA Standard **464A**.

**Quantity-Up to sixteen cards per NT8D37 IPE Module**

## NT8D16AA Digitone Receiver

### System Hardware-All

Purpose--Provides a total of eight channels of Dual Tone Multi Frequency (DTMF) detection. These channels are assigned on the DS30X loop. There is one 8 Kbps signaling channel provided for maintenance messaging and tone reporting.

The NT8D16AA Digitone Receiver allows access to the filters for parameter alterations in order to service different environments (e.g. international applications).

Quantity-Refer to *System engineering* (553-3001-151) for engineering details.

## QPC62 1.5 Baud Converter

### System Hardware-System option 21/51/61/71

Purpose-Used for Remote Peripheral Equipment (RPE) applications. Converts an SI-1 loop into two carrier loops. Used with 1.5 Mb/s Remote Peripheral Equipment (RPE). Contains switch-selectable line equalizers.

**Note:** QPC62F or later vintage is required.

Quantity-Two for each network loop, one in the local module and one in the remote module

## QPC63 Local Carrier Buffer

### System Hardware-System option 21/51/61/71

Purpose-Used for RPE applications. Performs the following functions:

- Generates from the 2.048 MHz clock a 1.544 MHz clock
- Decodes and provides enables for outgoing and incoming data
- Delays the data incoming **from** the carrier so that its frame relative to the outgoing data frame is equivalent to that returning from a peripheral buffer

- Relays line status **information** to the processor
- Decodes line control information from the processor

Note: **QPC63F** or later vintage is required.

**Quantity-One** for each network loop connected to the RPE Module at the local equipment location

## QPC65 Rernote Peripheral Switch

System Hardware-System option 21/51/61/71

Purpose-Used for **RPE** applications. Performs the following functions:

- Module, card, and line enables plus the bypass bit to the modules it serves at the remote site,
- Cyclic scanning of the terminals it serves for incoming signaling messages
- Monitoring of time slot 0 for outgoing messages
- Assembling incoming messages

Note: **QPC65G** or later vintage is required.

**Quantity—One** per network loop

## QPC66 2M Baud Converter

System Hardware-System option 21/51/61/71

**Purpose-Used** for **RPE** applications. Converts two carrier loops in to an Meridian 1 loop.

Note: **QPC66E** or later vintage is required.

**Quantity-Two** required for each network loop, one in the local module and one in the remote module.

## QPC67 Carrier Maintenance

**System Hardware**-System option 21/51/61/71

**Purpose**—Used for RPE applications. Contains an M-type (3017 Hz) **fault-locate** filter. Provides DC detection circuitry for the fault-locate pair, and carrier **loopback** relays to facilitate software maintenance testing. Terminates and gives access to the order wire pair via a jack and binding posts on the faceplate.

Note: **QPC67E** or later vintage is required.

**Quantity**—One per RPE Module

## QPC71 E&M/DX Signaling and Paging Trunk

**System Hardware**-All

Purpose-Used in **μ-Law** applications in one of the following ways to interface with appropriate types of trunk facilities:

- E&M signaling, 2-way dial repeating trunk
- 2-wire DX signaling, 2-way dial repeating **trunk**
- 4-wire DX signaling, 2-way dial repeating **trunk** (a **24V4** repeater, externally mounted, converts the trunk from 2- to 4-wire) --
- paging trunk or externally mounted loudspeaker

Refer to ***E&M/DX signaling and paging trunk- Circuit description (553-2001-187)*** for more details.

Each card contains two separate, identical trunk circuits. Trunk usage option is selected by switches on the circuit card.

**Note:** **QPC71F** or later vintage is required.

**Quantity**-One per two trunk circuits



## QPC99 Carrier Interface

System Hardware-System option 21/51/61/71

**Purpose-Used** for RPE applications. Contains two carrier line receivers with **7.5 dB pads built-in**. **Converts bipolar line signals into TTL level signals**. Provides facilities for carrier looping. Monitors **system** and invokes emergency transfer if carrier fails.

*Note:* **QPC99F** or later vintage is required.

Quantity-Two per network loop

## QPC1 92 Off-Premises Extension Line

System Hardware-All

**Purpose---**The Off-Premises Extension (OPX) line circuit interfaces with **500/2500-type** sets in  **$\mu$ -Law** applications. The loop range from the PE Module to station apparatus is **1400  $\Omega$**  excluding the set. This trunk may also be used when the line-to-line loss required is less than **5 dB**. Refer to **50012500 line packs-Description and operation** (553-2201-183) for more information.

Quantity-One per two OPX lines

## QPC237 4-wire E&M/DX signaling trunk

System Hardware-All

**Purpose!**-Used in  **$\mu$ -Law** applications in one of the following modes to interface with appropriate types of trunk facilities:

- E&M Signaling, 2-way dial repeating **trunk**
- 4-wire DX signaling, 2-way dial repeating trunk (**QPC237A/B** only)

Each trunk card has two **separate**, identical **trunk** circuits with a balanced terminating impedance of **600  $\Omega$** . **Trunk** usage options are selected by option switches on the pack. Refer to **Four-wire E&M/DX trunk circuit description** (553-2001-190).

*Note:* **QPC237D** or later vintage is required.

Quantity-Maximum of 10 cards per NT8D13 PE Module

## QPC250 Release Link Trunk

### System Hardware-All

Purpose-Used to interface a remote system, arranged for the Centralized Attendant Service (CAS) option, with the main system where CAS attendant is located. Refer to **Centralized Attendant Service (CAS) — Feature description and engineering** (553-2681-100) and **Release Link Trunk- Description, operation, and installation** (553-2681-180) for more information.

The card contains two separate, identical trunk circuits, with balanced terminating impedance of 900  $\Omega$ .

Note: QPC250B or later vintage is required.

Quantity-One per two Release Link Trunks

## QPC297 Attendant Console Monitor

### System Hardware—All

Purpose-Interfaces attendant consoles (including add-on modules) when the supervisory console feature is used. Allows the supervisory attendant to monitor calls being handled by attendants within the customer group.

Quantity-One per M1250/QCW4 console in systems using Supervisory Console feature

## QPC422 Tone Detector

### System Hardware-All

Purpose--Identifies tones and reports to CPU appropriately. Each card contains two tone detector circuits controlled by two microprocessors. Refer to **Tone Detector — Circuit description** (553-2001- 191) for more information.

Quantity-One per system

## QPC430 Asynchronous Interface Line

### System Hardware-All

**Purpose-**Provides four asynchronous line ports. Used in the SL- 1 Data Feature to interface to data equipment conforming to the EIA RS-422 standard. Refer **to *SL-1 Data Feature-General-description and provisioning*** (553-2731-100) for more information.

**Note:** QPC430F or later vintage is required.

**Quantity-**One per four data lines

## QPC432 4-Port Data Line

### System Hardware-All

**Purpose-**Provides four data-only ports for the SL-1 Dam Feature. Refer to ***SL-1 Data Feature — General description and provisioning (553-273 1-100)*** for more information.

**Note:** QPC432C or later vintage is required.

**Quantity—**One per four data ports

## QPC449 Loop Signaling Trunk

### System Hardware-All

**Purpose-**Interfaces the following 600 or 900  $\Omega$  trunks in p-Law applications:

- Direct Inward Dialing (DID)
- 2-way Tie, Dial Repeating (2DR)
- 2-way Tie, Outgoing Automatic Incoming Dial (OAID)
- Outgoing Automatic Number Identification (OANI)

The card contains four separate identical trunk circuits. Trunk usage option is selected by switches on the circuit card. Refer **to *Circuit pack option settings*** (553-3001-211) for more information.

**Quantity-**One per four loop signaling trunks

## QPC450 CO/FX/WATS Trunk

### System Hardware-All

Purpose-Interfaces four 600 or **900  $\Omega$**  CO, **FX** or WATS trunks with the system in  **$\mu$ -Law** applications. The card can also detect ringing on either the tip or ring leads and has provision to extend **the** normal loop range **from** 1200  $\Omega$  to 2600  $\Omega$  using balanced battery boost from the Central Office. Refer to **CO/FX/WATS trunk engineering description** ( 553-2201-185) for more information.

The card contains four separate identical trunk circuits. Trunk usage option is selected by switches on the circuit card.

Note: **QPC450E** or later vintage is required.

Quantity-One per four CO/IX/WATS trunks

## QPC578 Integrated Services Digital Line

### System Hardware-All

Purpose-Interfaces the Digital telephone sets and the associated ASCII terminals on Time Compression Multiplexing (**TCM**) loops to the system. Each card contains 16 separate line circuits, 8 Data circuits and 8 Voice-circuits.

Quantity--One per 16 digital lines

## QPC594 16-Port 500/2500 Line

### System Hardware-All

Purpose-Allows for 16 circuits per card (quad density) using p-law.

Quantity-One per 16 500/2500 lines

## QPC659 Dual Loop Peripheral Buffer

### System Hardware-All

Purpose-Interfaces one or two network loops. Also, a **Digitone** daughterboard can be used to convert multifrequency dialing signals from a

DIGITONE station to dc pulses suitable for processing in the system control.

Quantity-One per NT8D13 PE Module

## QPC723 RS-232 4-Port Interface Line

System Hardware-All

Purpose-This card provides four direct interfaces to RS-232 asynchronous ASCII computer equipment, such as asynchronous hosts, modems, standard off-the-shelf X.25 Packet Assembler/Disassembler (PAD), data PABXs and multiplexers.

Quantity-One per NT8D13 PE Module

## QPC789 16-Port 500/2500 Line (Message Waiting)

System Hardware-All

Purpose--Provides interface to up to 16 analog sets (500/2500) with Message Waiting lamp feature.

Quantity-One per 16 500/2500 Message Waiting lines

## QPC918 High-Speed Data Card

System Hardware-All

Purpose-Supports two data ports that operate independently of each other in synchronous/ssynchronous mode. Interfaces with any port on the QPC432 4-Port Data Line Card.

The High-Speed Data Card (HSDC) provides an interface to high speed synchronous devices, such as front end processors or video conferencing ports, through the Multi-Channel System (MCDS) and the PBX. In synchronous mode, it supports data speeds of up to 64 kbps. Refer to *QPC918 High-Speed Data Card -Description, installation, and operation* (553-2731-108) for more information.

Quantity-As required

---

# Station equipment

---

## Meridian Modular Telephones

The Meridian Modular Telephones are designed to provide cost effective integrated voice and data communication capability.

The following Meridian Modular Telephones are available:

- **M2006**—a single line telephone with 6 programmable keys
- **M2008**—a multi-line set with 8 programmable keys
- **M2616**—a high performance multi-line set with 16 programmable keys and integrated **Handsfree** unit
- **M2016S**—a Telephone Security Group Class II approved telephone designed to provide on-hook security. It is similar to the M2616, with 16 programmable keys, but has no handsfree capability.
- **M2216ACD-1**—a multi-line set for ACD operations. It has 15 programmable function keys, a special ACD Display Module and two FU-32 jacks for modular **electret** headsets
- **M2216ACD-2**—a multi-line set for ACD operations. It has 15 programmable function keys, and a special ACD Display. It is similar to model 1, but with one PJ-327 jack for a carbon agent headset and one RJ-32 jack for an **electret** supervisor headset

The following hardware options can be add on to Meridian Modular Telephones:

- External Alerter Interface Board
- Display Module
- Programmable Data Adapter

--- Key Expansion Module

Table 1 lists the ordering codes for the Meridian Modular Telephones, alone and with hardware options installed.

Table 2 lists the hardware options that can be purchased **separately**, and Table 3 lists miscellaneous items.

Refer to **Meridian Modular Telephones-Description and specifications** (553-2201-116) for additional information.

Table 1  
Order codes for Meridian Modular Telephones and factory installed options

Description	Ordering code
<b>M2006 (Basic)</b>	
Black	NTZK06AA-03
Chameleon Ash	NTZK06AA-35
Dolphin Gray	NTZK06AA-93
<b>M2006 (with MPDA)</b>	
Black	NTZK06AB-03 (with power board)
Chameleon Ash	NTZK06AB-35 (with power board)
Dolphin Gray	NTZK06AB-93 (with power board)
<b>M2008 (Basic)</b>	
Black	NTZK08AA-03
Chameleon Ash	NTZK08AA-35
Dolphin Gray	NTZK08AA-93
-continued ---	

**Table 1**  
**Order codes for Meridian Modular Telephones and factory installed options**  
**(continued)**

Description	Ordering code
<b>M2008 (with MPDA)</b>	
Black	<b>NTZK08AB-03</b> (with power board)
Chameleon Ash	<b>NTZK08AB-35</b> (with power board)
Dolphin Gray	<b>NTZK08AB-93</b> (with power board)
<b>M2008 (with Display)</b>	
Black	<b>NTZK08BA-03</b> (with power board)
Chameleon Ash	<b>NTZK08BA-35</b> (with power board)
Dolphin Gray	<b>NTZK08BA-93</b> (with power board)
<b>M2008 (with MPDA and Display)</b>	
Black	<b>NTZK08BB-03</b> (with power board)
Chameleon Ash	<b>NTZK08BB-35</b> (with power board)
Dolphin Gray	<b>NTZK08BB-93</b> (with power board)
<b>M2616 (basic)</b>	
Black	<b>NTZK16AA-03</b>
Chameleon Ash	<b>NTZK16AA-35</b>
Dolphin Gray	<b>NTZK16AA-93</b>
<b>M2616 (with MPDA)</b>	
Black	<b>NTZK16AB-03</b> (with power board)
Chameleon Ash	<b>NTZK16AB-35</b> (with power board)
Dolphin Gray	<b>NTZK16AB-93</b> (with power board)
-continued —	



**Table 1**  
**Order codes for Meridian Modular Telephones and factory installed options**  
**(continued)**

Description	Ordering code
<b>M2616 (with Display)</b>	
Black	<b>NTZK16BA-03</b>
Chameleon Ash	<b>NTZK16BA-35</b>
Dolphin Gray	<b>NTZK16BA-93</b>
<b>M2616 (with MPDA and Display)</b>	
Black	<b>NTZK16BB-03</b> (with power board)
Chameleon Ash	<b>NTZK16BB-35</b> (with power board)
Dolphin Gray	<b>NTZK16BB-93</b> (with power board)
<b>M2016S (basic)</b>	
Black	<b>NTZK20AA-03</b> (with power board)
Chameleon Ash	<b>NTZK20AA-35</b> (with power board)
Dolphin Gray	<b>NTZK20AA-93</b> (with power board)
<b>M2016S (with MPDA)</b>	
Black	<b>NTZK20AB-03</b> (with power board)
Chameleon Ash	<b>NTZK20AB-35</b> (with power board)
Dolphin Gray	<b>NTZK20AB-93</b> (with power board)
-continued —	

**Table 1**  
**Order codes for Meridian Modular Telephones and factory installed options**  
**(continued)**

Description ,	Ordering code
<b>M2016S (with Display)</b>	
Black	NTZK20BA-03 (with power board)
Chameleon Ash	NTZK20BA-35 (with power board)
Dolphin Gray	NTZK20BA-93 (with power board)
<b>M2016S (with MPDA and Display)</b>	
Black	
Chameleon Ash	NTZK20BB-03 (with power board)
Dolphin Gray	NTZK20BB-35 (with power board)
	NTZK20BB-93 (with power board)
<b>M2216ACD-1 (basic-with ACD Display)</b>	
Black	NTZK22AA-03
Chameleon Ash	NTZK22AA-35
Dolphin Gray	NTZK22AA-93
<b>M2216ACP1 (with MPDA and ACD Display)</b>	
Black	NTZK22AB-03 (with power board)
Chameleon Ash	NTZK22AB-35 (with power board)
Dolphin Gray	NTZK22AB-93 (with power board)
-continued —	

Table 1

Order codes for Meridian Modular Telephones and factory **installed options**  
(continued)

Description	Ordering code
<b>M2216ACP2 (basic-with ACD Display)</b>	
Black	<b>NTZK23AA-03</b> (with power board)
Chameleon Ash	<b>NTZK23AA-35</b> (with power board)
Dolphin Gray	<b>NTZK23AA-93</b> (with power board)
<b>M2216ACD-2 (with MPDA)</b>	
Black	<b>NTZK23AB-03</b> (with power board)
Chameleon Ash	<b>NTZK23AB-35</b> (with power board)
Dolphin Gray	<b>NTZK23AB-93</b> (with power board)

**Table 2**  
**Ordering codes for optional hardware**

Description	Ordering code	Additional requirements
<b>Meridian Progammable Data Adapter</b>	<b>NT2K64WA</b>	Power Supply Board
<b>Display Module</b>		Power Supply Board (M2008)
Black	<b>NT2K24WA-03</b>	
Chameleon Ash	<b>NT2K24WA-35</b>	
Dolphin Gray	<b>NT2K24WA-93</b>	
<b>ACD Display Module</b>		Power Supply Board (M2008)
Black	<b>NT2K25YH-03</b>	
Chameleon Ash	<b>NT2K25YH-35</b>	
Dolphin Gray	<b>NT2K25YH-93</b>	
<b>Top cover filler plate</b>		
Black	<b>PO778303-03</b>	
Chameleon Ash	<b>PO77833535</b>	
Dolphin Gray	<b>PO778393-93</b>	
<b>22 Key Expansion Module</b>		Power Supply Board
Black	<b>NT2K22WA-03</b>	
Chameleon Ash	<b>NT2K22WA-35</b>	
Dolphin Gray	<b>NT2K22WA-93</b>	
<b>Single Key Module Footstand</b>		
Black	<b>PO7801 03-03</b>	
Chameleon Ash	<b>PO7801 35-35</b>	
Dolphin Gray	<b>PO7801 93-93</b>	
-continued —		

**Table 2**  
**Ordering codes for optional hardware (continued)**

Description	Ordering code	Additional requirements
<b>Double Key Module Footstand</b>		
<b>Black</b>	<b>PO780203-03</b>	
Chameleon Ash	PO78023535	
Dolphin Gray	<b>PO780293-93</b>	
External Alerter Interface	<b>NT2K40WA</b>	Power Supply Board
Power Supply Board	<b>NT2K10WA</b>	Transformer or closet power
120 V Transformer	A0367335	Power Supply Board
240 V Transformer	A036791 4	Power Supply Board

**Table 3**  
**Ordering codes for miscellaneous items**

Description	Ordering code
<b>Card, Directory Number</b>	
<b>Black</b>	P O 6 6 5 3 5 2
Chameleon Ash	PO665352
Dolphin Gray	PO652746
Card, key labels	PO657709
Lens, Directory Number	PO652720
<b>Handset</b>	
Black	<b>A0338908</b>
Chameleon Ash	A0329 173
Dolphin Gray	A03291 74
<b>Handset cord, 2.7m. (9 ft)</b>	
Black	A0334590
Chameleon Ash	<b>A031</b> 8327
Dolphin Gray	A031 8330
<b>Handset cord, 3.6 m. (12 ft)</b>	
Black	A0274233
Chameleon Ash	A0274243
Dolphin Gray	A031 4423
Line cord	A0346862
<b>-continued --</b>	

**Table 3**  
**Ordering codes for miscellaneous items (continued)**

<b>Description</b>	<b>Ordering code</b>
Set User Guide (regular)	PO703991
Set Reference Card	PO704094
Display Module Reference Card	PO704096
Display Installation Sheet	PO706836
Meridian Programmable Data Adapter User Guide	PO705986
<b>M2216ACD</b> User Guide	PO704747
ACD Reference Card	PO705952

## **M2000 series digital telephones**

The following types of **M2000** digital telephones are available for integrated voice and **data communications**:

The **M2009 (NT1F05)** has 9 keys for features and lines

— The **M2018 (NT1F07)** has 18 keys for features and lines

The **M2112 (NT1F07)** has 12 keys which are as follows:

- 11 keys for features and lines
- one key **to** control the built-in **handsfree** feature

— The **M2317** has 17 keys which are as follows:

- 11 programmable keys
- one key to control the built-in **handsfree** feature
- five soft keys which are programmable for software features

An asynchronous data option circuit board (**NT1F09**) and data option power supply (**NPS50220-04L1**) are available for the **M2000** series digital telephones to provide for connecting data terminals to the sets.

For additional information on these telephones, refer to **M2000 Digital Telephones • Description, Installation, Operation, and Maintenance** (553-2201-110).

## M3000 Touchphone

The **M3000** (**NT1F1 1**) Touchphone is a digital integrated voice and data telephone with a touch sensitive Liquid Crystal Display (LCD) screen for feature implementation. Refer to **Meridian M3000 Touchphone — Description, installation, operation, and maintenance** (553-2201-115) for additional information.

An asynchronous data option circuit board (**NT1F10**) and data option power supply (**TEC 00020**) are available to provide for connecting data terminals to the sets.

## NE-500/2500 telephone set

These are standard single line **500-type** rotary dial sets and **2500-type** **Digitone** pushbutton dial sets that may be used with the Meridian 1 system.

Standard 48-V talk battery and **20-Hz** ringing voltage are available so that conventional equipment such as telephone answering, dictation, data sets, modems, key telephones, can be used with the Meridian 1 system.

If the message waiting lamp feature is required, use **NE-500YR**, **NE-2500YQA** sets.

## MI250 and 2250 attendant consoles

The **MI250** and **M2250** incorporate design improvements based on the Attendant Console **QCW4E** and are functionally compatible with the **QCW4**. The **MI250** is driven and powered by analog line cards and is compatible with **QCW4** console cabling schemes. The **M2250** is driven and powered by a digital line card and has a modified cabling scheme. The following list describes the applications for **SL-1** System attendant consoles.

- The **MI250** is designed to work in analog mode and functions through an analog line card when connected to a digital switch.



- The M2250 is a digital version of **the M1250**, offering additional features. A digital link connects the M2250 to the switch.

Refer to **M1250** and **M2250** Attendant **Consoles description** (553-2201-117) for additional information.



## Attendant administration overlay template

This plastic overlay is placed over the attendant console to indicate the key functions when using the Attendant Administration feature. Order number is PO613887. Refer to **X11 features and services** (553-3001-305) for more details.

## QMT1 and QMT2 key/lamp expansion modules

These modules allow the expansion of key/lamp field of QSU-type telephone sets or QCW-type attendant consoles for additional directory number and feature activation facilities. These modules require a **local 24 V** plug-in transformer or a **QUT1** centralized power unit.

- **QMT1** - consists of one XI-button nonlocking key strip
- **QMT2** - consists of two lo-button nonlocking key strips.

## QMT3 lamp field array module

This is an add-on module for QSU-type telephone sets or QCW-type attendant consoles to display the busy-idle status of 150 consecutive stations. It requires a local 15 V plug-in transformer or a **QUT1** centralized power unit. Refer to **QSU-Telephone Sets, Add-On Modules, interface kits and Meridian M1000 Series Telephones description** (553-2001-1 10) for more information.

## QMT4 handset module

This module is used as a handset cradle to hold the attendant console handset. No active components are contained inside the module.

This module includes the NE-G3 handset. It may be attached to the console or left freestanding. It contains two jacks to accommodate a standard headset or handset plug when module is attached to the console. It also allows hearing aids to be coupled with telephone adaptors to the handsets. Refer to **Attendant Consoles and Add-On Modules-Description** (553-2001-1 15) for more information.



If QCW4E or later vintage is used, either a QMT4C must be used or the QMT4A or QMT4B must be used as standalone cradles.

## QMT1 1 asynchronous/ synchronous interface module

The Asynchronous/Synchronous Interface Module (ASIM) is similar to the QMT9 but provides added dialing capabilities and six data feature keys and associated lamps and data control switches. Refer to *SL-1 Data Feature — General description and provisioning* (553-2731-100) for more information.

## QMT12 add-on data module

The synchronous ADM provides a CCITT V.35 interface between the Meridian 1 system and customer-supplied dam equipment. Refer to *SL-1 Data Feature-General description and provisionin* (553-2731-100) for more information.

Each ADM requires a local supplementary power supply such as the PO593922 or PO610756 transformer.

## QMT1 5 amplified handset module

This module is similar to the QMT4 module, with addition of an amplifier for the hearing impaired. It includes a volume control, 2 headset plugs on the right side of the module which plug into the headset jacks on the console. It also has 2 headset/handset plugs on the left side. One (attendant jack) is under control of the amplifier; the second (supervisor jack) cannot have its volume adjusted.

## QMT21 high-speed data module

This module is similar to the QMT11 module. It provides RS-232/V.35 interface and allows synchronous data transmission of up to 64 kbps. It provides connectivity to the Data Terminal Equipment (DTE) for intra-switch communications, as well as wide area communications over DTI/PRI links to other Northern Telecom switches. Refer to *QMT21 High-Speed Data Module -Description, installation, and operation* (553-2731-107) for more information.

## QUS1 logic handsfree unit

This unit provides handsfree voice switching facilities on the SL-1 telephone. Refer to 512-6251-200 for a complete description.

## QKK1 handsfree remote powering kit

This kit is used to modify SL- 1 telephone sets for use **with** the QUS 1 Logic **handsfree** unit and to extend the SL-1 set operating range from 1830 m (6000 ft) to 2438 m (8000 ft). It requires a 24 V ac local transformer (ordered separately).

This kit is field-installable inside a set. Refer to **QSU-Telephone Sets, Add-On Modules, interface kits and Meridian M1000 Series Telephones description** (553-2001-1 10) for more information.

## QKK3 automatic handsfree interface kit

This kit is the same as **QKK1** for systems with the Automatic Answer feature. It automatically answers calls after a single ring (see **QKK8** and refer to **QSU-Telephone Sets, Add-On Modules, interface kits and Meridian M1000 Series Telephones description** (553-2001-1 10)).

## QKK8 automatic handsfree interface kit

This kit is the same as **QKK3** but for **QSU71** sets only.

## QKM13 light probe kit

This kit enables a sight-impaired person to use existing consoles and SL-1 sets. The probe consists of a small hand-held box with a light sensor. When the sensor is placed over an LED that is on, a tone is heard in the handset or headset. Refer to **Attendant Consoles and Add-On Modules description** (553-2001-1 15) for more information. Two PO590352 connector kits are required to install the light probe into an SL-1 set.

## QKN1 headset kit

This kit is used to modify QSU-type telephone set for **NE-52-type** Venture 1 or equivalent headset operation. Refer to **QSU-Telephone Sets, Add-On Modules, interface kits and Meridian M1 000 Series Telephones description** (553-2001-1 10) for more information.

This kit provides the following features:

- field-installable inside a set
- jack and ON-OFF switch are located in the filler plate position on the left-hand side of the set



--



- no supplementary power is required

## QSR2 venture 1 headset

This set is used in conjunction with the **QKN1** headset kit to provide head telephone set operation. Refer to **QSU-Telephone Sets, Add-On Modules, interface kits and Meridian M1 000 Series Telephones description** (553-2001-110) for more information.

This headset provides the following features:

- lightweight (17 g)
- ear-mounted — left or right
- six different sizes of **ear tips**
- acoustic, noise-canceling transmitter held close to user's mouth by a thin, plastic covered, stainless steel arm attached to **the** headset capsule

## QSAM2A and QSAM3A group listening switch kit

This kit allows the speech of both parties to be heard through the speaker of the SL-1 set. Refer to **QSU-Telephone Sets, Add-On Modules, interface kits and Meridian M1000 Series Telephones description** (553-2001-110) for more information.

An ON/OFF switch is mounted in the left-hand filler plate of a QSU-type set. When ON, the speech of the SL-1 set user and the connected party are heard through the speaker of the SL-1 set. When OFF, the SL-1 set functions normally.

- **QSAM2A** used on phase I SL-1 sets
- **QSAM3A** used on phase II SL-1 sets, (**QSU1F** and later vintage)

## Asynchronous data options

These microprocessor-controlled devices provide the interface (RS-232 compatible) through which ASCII Data Terminal Equipment (DTE) may be connected to the Meridian 1 network. Two types of asynchronous data options are available for use with the following digital telephones:

- **NT1F09AA** printed circuit board for use with **M2009**, **M2018** and **M2112** digital telephones. Refer to **Meridian M2000 Digital**

**Telephones -Description, installation, operation, and maintenance** (553-2201-1 10) for more information.

- **NT1F10AA** printed circuit board assembly and housing for **M3000** digital touchphone. Refer to **Meridian M3000 Touchphone — Description, installation, operation, and maintenance** (553-2201-1 15) for additional information.

The following features are available:

- Automatic data rate detection at all rates using the ASCII “Carriage Return” character
- Keyboard dialing for originating data calls to local and remote hosts or DTE from the terminal keyboard
- Break detection and generation

## Meridian programmable data adapter

This adapter provides the interface (RS-232 compatible) through which ASCII Data Terminal Equipment (DTE) may be connected to the Meridian 1 network. It is available with the **M2006, M2008, M2016S, and M2616** Meridian Modular Telephones

Some of the features available are as follows:

- keyboard dialing for originating data calls to local or remote hosts or DTE
- telephone keypad dialing for originating and releasing data calls
- parameter setting from telephone keypad
- voice call origination from terminal keyboard
- script file capabilities to pre-program resource locations via mnemonic address names

## Teledapt™

Teledapt standardized telephone connectorization for QSU-type sets provides an alternative to the conventional spade tip form of set termination.

QSU-type sets possessing the Teledapt capability are designated by “**QM**” suffix on the set code (i.e., the **QSUIEQM**). while “QM” sets use a 2 m (7 ft) cord, the **NE-D6QF** Teledapt cord assembly may be ordered

separately in 2 m (7 ft), 4 m (14 ft), or 7.5 m (25 ft) lengths for conversion of existing SL-1 sets. These assemblies are compatible only with the Teledapt jacks designed for the system.

## Station equipment replaceable items

Table 4 lists the individual parts of the station equipment that **are field-replaceable**. These parts may be ordered by using the given apparatus number.

**Table 4**  
**Station equipment replaceable items**

Equipment	Replaceable items	Apparatus number
<b>QCW-Type</b> Attendant Consoles  <b>QCW1, QCW2</b> only  <b>QCW3, QCW4</b> only (see Note)  <b>M2006, M2008, M2016S, M2216,</b> and M2616 sets	Cover Assembly	PO538435
	Attendant Administration	PO61 3887
	Overlay	PO58631 2
	Console Caps Package	PO567037
	Bezel	PO578254
	Bezel	PO536503
	Dial Pad	PO548801
	LED Assembly (1 strip)	PO548799
	LED Assembly (2 strips)	P O 5 4 8 8 0 0
	LED Assembly (3 strips)	<b>NE-D50QE-35</b>
	Line Cord	PO578270
	8-Digit Display (QCW2)	QPC246
	Key button strip PCB (QCW3 only)	QPC247
	Key button strip PCB	QPC248
	Key button strip PCB	P0665352, P0652740
	Directory Number Card	P0657709
	Key Label Card	P0652720
	Directory Number Lens	
	Handset	
	Black	A0338908
Chameleon Ash	A03291 73	
Dolphin Gray	A0329 174	
Handset Cord (2.7 m/g ft)		
Black	A0334590	
<b>-continued -</b>		

**Table 4**  
**Station equipment replaceable items (continued)**

Equipment	Replaceable items	Apparatus number
All Sets and Consoles	Chameleon Ash	AO318327
	Dolphin Gray	A031 8330
	Handset Cord (3.6 m/l 2 ft)	
	Black	A0274233
	Chameleon Ash	A0274243
	Dolphin Gray	A031 4423
	Line Cord	A0346862
	Card Holder	PO535652
Filler Plate	PO523535	
<p><b>Note:</b> The QCW3 houses one QPC246, one QPC247 and one QPC248. The QCW4 houses one QPC247 and two QPC248 PCBs (right and left).</p>		





---

## Cabling

---

The cables are differentiated by the cabling method used. Two types of cables are available.

Intra-UEM cables are cables that connect to different cards within a UEM, or cables that go to the I/O connector panels at the rear of the UEM.

Intra-UEM cables are not shielded. These cables are typically round and use bail locks or screws to prevent accidental removal.

Inter-UEM cables are cables that are routed internally between UEMs. These cables are used primarily for interconnecting the following subsystems together:

- CPU to CPU
- CPU to Network
- Network to Network
- Network to Peripheral Equipment

All of the faceplate connectors use a **90-degree** cable egress and all of the backplane connectors use a **180-degree** cable egress.

### **NT7D1 1AE** module-to-module power harness

**Purpose**—This power wiring harness is used in DC modules to connect the input DC power and speed control signals vertically through the column. It is constructed in a modular form, and can be disconnected when necessary to allow for the removal and/or replacement of modules. The DC power harness is larger than that of the AC system since it requires the use of more input wires in order to handle the lower voltage and its associated higher current.

### **NT8D40AA AC power cord**

Purpose--This cable conducts AC power into the pedestal for AC systems. It is 9.1 m (30 ft) long.



### **NT8D40AM module-to-module power harness**

Purpose--This power wiring harness is used in AC modules to connect the input AC power and speed control signals vertically through the column. It is constructed in a modular form, and can be disconnected when necessary to allow for the removal and/or replacement of modules.

### **NT8D40AY AC power cord**

Purpose--This cable conducts AC power into the pedestal for System options 21A. It is 2.7 m (9 ft) long.

### **NT8D40BJ System Monitor to backplane cable**

Purpose--This cable is used for System option 21A. It connects the System Monitor to the common/peripheral equipment backplane to allow control and monitoring of the system.

### **NT8D40BK System Monitor trip cable**

Purpose--This internal cable is used for System option 21A. It connects the System Monitor to the power distribution unit. It allows the System Monitor to trip the circuit breaker.

### **NT8D46AA System Monitor column cable**

Purpose--This cable is used to connect the monitoring signals vertically through the column. It is constructed in a modular form, and can be disconnected when necessary to allow for the removal and/or replacement of modules.

### **NT8D46AC Thermostat harness**

Purpose--The thermostat harness is part of the Temperature Sensor Assembly. It contains two thermal sensors and a fault LED. At 70degree Celsius, the thermal sensors trip and cause system shutdown. The thermostat harness plugs into the backplane of the top module.



## NT8D46AD System Monitor SDI cable

**Purpose**—This cable is used to connect an SDI card to the System Monitor. It replaces the NT8D46AA System Monitor column cable when the SDI is in the same UEM.

## NT8D46AG System Monitor to SDI paddle board cable

**Purpose**—This cable is used to connect the System Monitor to the NT8D41AA SDI paddle board (dual port). It replaces the NT8D46AA System Monitor column cable when the NT8D41AA SDI paddle board (dual port) is in the same UEM.

## NT8D46AH System Monitor to MDF cable

**Purpose**—This cable is used to connect the System Monitor Power Fail Transfer Unit to the MDF.

This cable is 9.7 m (32 ft) long.

## NT8D46AJ System Monitor to UPS (Best) cable

**Purpose**—This cable is used to connect the System Monitor to the Best Uninterruptable Power Supply (UPS). It is used for UPS monitoring.

This cable is 13.7 m (45 ft) long.

## NT8D46AL System Monitor Serial Link cable

**Purpose**—This cable is used to connect the System Monitor from one column to another.

This cable is 2.1 m (7 ft) long.

## NT8D46AM Air Probe harness AC

**Purpose**—The Air Probe harness AC is part of the Temperature Sensor Assembly and is used in AC systems. It uses a 24-pin connector. It senses exit air temperature and relates the information to the blower unit.

## **NT8D46AP Extended System' Monitor Serial Link cable**

**Purpose**—This cable is used to connect the System Monitor from one column to another.

This cable is 7.6 m (25 ft) long.

## **NT8D46AQ System Monitor to UPS (Exide) cable**

**Purpose**—This cable is used to connect the System Monitor to the Exide UPS. It is used for UPS monitoring.

This cable is 13.7 m (45 ft) long.

## **NT8D46AS System Monitor inter-CPU cable**

**Purpose**—This cable is used to connect the dual CPUs in Meridian 1 System option 71 together for System Monitor monitoring. It replaces the NT8D46AA System Monitor column cable in both CPU modules.

## **NT8D46AT System Monitor to QBL15 cable**

**Purpose**—This cable connects the System Monitor to the QBL15 power/battery distribution box. It is used to monitor the DC power plant.

This cable is 9.7 m (32 ft) long.

## **NT8D46AU System Monitor to UPS (Alpha) cable**

**Purpose**—This cable is used to connect the System Monitor to the Alpha UPS. It is used for UPS monitoring.

This cable is 13.7 m (45 ft) long.

## **NT8D46AV System Monitor to QCA13 cable**

**Purpose**—This cable connects the System Monitor to the QCA13 DC power plant. It is used to monitor the DC power plant.

This cable is 9.7 m (32 ft) long.

## NT8D46AW System Monitor to QBL12 cable

**Purpose**—This cable connects the System Monitor to the QBL12 battery distribution box. It is used to monitor the DC power plant.

This cable is 9.7 m (32 ft) long.

## NT8D46DC Air Probe harness DC

**Purpose**—The Air Probe harness DC is part of the Temperature Sensor Assembly and is used in DC systems. It uses a 36-pin connector. It senses exit air temperature and relates the information to the blower unit.

## NT8D73 Inter-cabinet Network cable

**Purpose**--This cable is used to interconnect QPC414 Network cards:

- from Network Module to PE Module via the I/O connector panels
- from QCA55 cabinet to PE Module

This cable is available in the following lengths:

- NT8D73AD 1.8 m (6 ft)
- NT8D73AF 3.6 m (12 ft)
- NT8D73AL 6 m (20 ft)
- NT8D73AS 9.1 m (30 ft)

## NT8D74 Clock Controller to Inter Group cable

**Purpose**—This cable is used to connect the QPC47 1 Clock Controller card to the NT8D36AA Inter Group Module.

This cable is available in the following lengths:

- NT8D74AC 1.2 m (4 ft)
- NT8D74AD 1.8 m (6 ft)
- NT8D74AE 2.4 m (8 ft)
- NT8D74AF 3 m (10 ft)
- NT8D74A.I 4.8 m (16 ft)

## NT8D75 Clock Controller to Clock Controller cable

**Purpose-**This cable is used to interconnect QPC471 Clock Controller cards.

This cable is available in the following lengths:

- NT8D75AC 1.2 m (4 ft)
- NT8D75AD 1.8 m (6 ft)

## NT8D76 Intergroup Switch to Inter Group cable

**Purpose-**This cable is used to connect the QPC412 Intergroup Switch card to the NT8D36AA Inter Group Module.

This cable is available in the following lengths:

- NT8D76AC 1.2 m (4 ft)
- NT8D76AD 1.8 m (6 ft)
- NT8D76AE 2.4 m (8 ft)
- NT8D76AF 3 m (10 ft)
- NT8D76AG 3.6 m (12 ft)
- NT8D76A.1 4.8 m (16 ft)
- NT8D76AL 6 m (20 ft)
- NT8D76AP 7.6 m (25 ft)

## NT8D77 FDI to FDU cable

**Purpose!**-This cable is used to connect the QPC742 FDI card to the NT8D68AA FDU card.

This cable is available in the following lengths:

- NT8D77AB 0.6 m (2 ft)
- NT8D77AA 0.9 m (3 ft)
- NT8D77AC 1.2 m (4 ft)
- NT8D77AD 1.8 m (6 ft)

---

## NT8D78AA CPU cable

Purpose--This cable is used to connect the QPC580 CPU Interface card to QPC579 CPU Function card.

This cable is 5 cm (2 in.) long.

## NT8D79 PRI/DTI to Clock Controller cable

Purpose--This cable is used to connect the PRI/DTI card to the QPC471 Clock Controller card.

This cable is available in the following lengths:

- NT8D79AB 0.6 m (2 ft)
- NT8D79AC 1.2 m (4 ft)
- NT8D79AD 1.8 m (6 ft)
- NT8D79AE 2.4 m (8 ft)
- NT8D79AF 3 m (10 ft)

## NT8D80 CPU interface cable

Purpose--This cable is used to connect the following:

- QPC581 CMA card to QPC581 CMA card in a dual CPU configuration
- QPC584 MSI card to NT8D69AA MDU
- QPC215 Segmented Bus Extender in CPU to Network via QPC441 3PE
- QPC441 3PE in Network 0 to QPC441 3PE in Network 1 (Meridian 1 System option 61 only)

This cable is available in the following lengths:

- NT8D80AB 0.6 m (2 ft)
- NT8D80AC 1.2 m (4 ft)
- NT8D80AZ 1.5 m (5 ft)
- NT8D80AD 1.8 m (6 ft)
- NT8D80AE 2.4 m (8 ft)



- NT8D80AF      3 m (10 ft)
- NT8D80AG      3.6 m (12 ft)
- NT8D80AJ      4.8 m (16 ft)
- NT8D80AL      6 m (20 ft)
- NT8D80AP      7.6 m (25 ft)



## NT8D81AA Tip and Ring cable

Purpose-This cable is used to connect a line card to the I/O connector panel.

This cable is 50 cm (20 in.) long.

## NT8D82 SDI to I/O cable

Purpose-This cable is used to connect the the following cards to the I/O connector panel:

- QPC757 D-Channel Handler Interface
- QPC513 Enhanced Serial Data Interface
- QPC84 1 Four-Port Serial Data Interface
- QPC687 CPU with SDI/ RTC

This cable is available in the following lengths:

- NT8D82AC      1.2 m (4 ft)
- NT8D82AD      1.8 m (6 ft)

## NT8D83 PRI/DTI to I/O cable

Purpose-This cable is used to connect the PRI/DTI card (T1 port) to the I/O connector panel.

This cable is available in the following lengths:

- NT8D83AC      1.2 m (4 ft)
- NT8D83AD      1.8 m (6 ft)



---

## NT8D84AA SDI paddle board (dual. port) to I/O cable

Purpose-This cable is used to connect the NT8D41AA SDI paddle board (dual port) to the I/O connector panel.

This cable is 45.7 cm (18 in.) long.

## NT8D85 Network to PE cable

Purpose-This cable is used to connect the following:

- QPC58 1 CMA card to QPC58 1 CMA card in dual CPU configuration
- QPC414 Network card to PRI/DTI card
- QPC414 Network card to QPC659 Dual Loop Peripheral Buffer card (for internal cabling only)
- QPC659 Dual Loop Peripheral Buffer card to QPC659 Dual Loop Peripheral Buffer card when connecting two NT8D13 PE Modules together

This cable is available in the following lengths:

- NT8D85AB 0.6 m (2 ft)
- NT8D85AC 1.2 m (4 ft)
- NT8D85AZ 1.5 m (5 ft)
- NT8D85AD 1.8 m (6 ft)
- NT8D85AE 2.4 m (8 ft)
- NT8D85AF 3 m (10 ft)
- NT8D85AJ 4.8 m (16 ft)
- NT8D85AL 6 m (20 ft)
- NT8D85AP 7.6 m (25 ft)
- NT8D85AT 10.6 m (35 ft)
- NT8D85AV 13.7 m (45 ft)

## **NT8D86 Network to I/O cable-**

Purpose!-This cable is used to connect the following to the I/O connector panel:

- QPC414 Network card
- PRI/DTI card
- QPC659 Dual Loop Peripheral Buffer card
- NT8D47 RPE

This cable is available in the following lengths:

- NT8D86AC      1.5 m (5 ft)
- NT8D86AD      1.8 m (6 ft)

## **NT8D87 Conference/TDS to music trunk cable**

Purpose-This cable is used to connect the **NT8D17AA** Conference/IDS card to the music trunk or I/O connector panel.

This cable is available in the following lengths:

- NT8D87AC      1.2 m (4 ft)
- NT8D87AD      1.8 m (6 ft)

## **NT8D88 Network to I/O cable**

Purpose--This cable connects the **NT8D04AA** Superloop Network card to the I/O connector panel.

This cable is available in the following lengths:

- NT8D88AC      1.5 m (5 ft)
- NT8D88AD      1.8 m (6 ft)

## **NT8D90AF SDI multiple-port cable - internal**

Purpose-This is a multiple-port extension cable for QPC841 Four-Port SDI card. This cable is used to connect from the I/O connector panel to the **NT8D96AB** cable.

This cable is 3 m (10 ft) long.



## NT8D91 Network to Controller cable

Purpose-This cable is used for internal cabling to connect NT8D04 Superloop Network card to NT8D01AD Controller-2 or NT8D01AC Controller-4 card.

This cable is available in the following lengths:

— NT8D91AC	1.2 m (4 ft)
— NT8D91AD	1.8 m (6 ft)
— NT8D91AE	2.4 m (8 ft)
— NT8D91AF	3 m (10ft)
— NT8D91AG	3.6 m (12 ft)
— NT8D91AJ	4.8 m (16 ft)
— NT8D91AP	7.6 m (25 ft)
— NT8D91AT	10.6 m (35 ft)
— NT8D91AV	13.7 m (45 ft)

## NT8D92AB Controller to I/O cable

Purpose-This cable is used to connect the NT8D01 Controller card to the I/O connector panel. This method of cabling is used only when the Network loop is cabled externally to the UEM.

This cable is 50 cm (20 in.) long.

## NT8D93 SDI paddle board (dual port) I/O to DTE/DCE cable

Purpose-This cable is used to connect the NT8D41AA SDI paddle board (dual port) to the DTE or DCE via the I/O connector panel.

This cable is available in the following lengths:

— NT8D93A.1	4.8 m (16 ft)'
— NT8D93AW	14.6 m (48 ft)

## NT8D95 SDI I/O to DTE/DCE cable

Purpose--This cable is used to connect the following cards to the DTE or DCE via the I/O connector panel:

- QPC513 Enhanced **Serial** Data Interface
- **QPC841** Four-Port Serial Data Interface
- QPC687 CPU **with SDI/ RTC**

This cable is available in the following lengths:

- **NT8D95AJ** 4.8 m (16 ft)
- **NT8D95AT** 10.3 m (34 ft)
- **NT8D95AW** 14.6 m (48 ft)

### **NT8D97AX PRI/DTI I/O to MDF cable**

**Purpose**—This cable connects the **PRI/DTI** card to the MDF via the I/O connector panel.

This cable is 15.2 m (50 ft) long.

### **NT8D98 Inter-cabinet Network cable**

**Purpose**—This cable is used to interconnect **NT8D04AA** Superloop Network cards:

- from Network Module to IPE Module via the I/O connector panels
- from **QCA55** cabinet to IPE Module

This cable is available in the following lengths:

- **NT8D98AD** 1.8 m (6 ft)
- **NT8D98AF** 3.6 m (12 ft)
- **NT8D98AL** 6 m (20 ft)
- **NT8D98AS** 9.1 m (30 ft)
- **NT8D98AT** (not for **QCA55** cabinet application) 11.5 m (38 ft)

---

## NT8D99 CPU to Network cable

Purpose-This cable is used to:interconnect NT8D35 NET Modules in full group configuration

This cable is available in the following lengths:

- NT8D99AB 0.6 m (2 ft)
- NT8D99AC 1.2 m (4 ft)
- NT8D99AD 1.8 m (6 ft)

## NT9J93AD PRI/DTI Echo Canceler to I/O cable

Purpose-This cable is used to connect the PRI/DTI Echo Canceler port to the I/O connector panel.

This cable is 1.8 m (6 ft) long.

## NT9J94AB RPE to I/O cable

Purpose-This cable is used to connect the NT8D47 RPE to the I/O connector panel.

This cable is 0.6 m (2 ft) long.

## NT9J96 Intra-cabinet Network cable

Purpose-This cable is used to connect the QPC414 Network card to the I/O connector panel within an existing SL-1 cabinet (QCA55).

This cable is available in the following lengths:

- NT9J96AC 1 m (40 in.)
- NT9J96AD 1.8 m (70 in.)
- NT9J96AE 2.2 m (85 in.)
- NT9J96AG 3.6 m (12 ft)
- NT9J96AH 4.3 m (14 ft)
- NT9J96AJ 4.9 m (16 ft)

## NT9J97 Intra-column Network cable

Purpose-This cable is used to connect the **NT8D04AA** Superloop Network card to the I/O connector panel in a **QCA55** cabinet.

This cable is available in the following lengths:

- **NT9J97AC**      1 m (40 in.)
- **NT9J97AD**      1.8 m (70 in.)
- **NT9J97AE**      2.2 m (85 in.)
- **NT9J97AG**      3.6 m (12 ft)
- **NT9J97AH**      4.3 m (14 ft)
- **NT9J97AJ**      4.9 m (16 ft)

## NT9J98 Intra-cabinet Network cable

Purpose-This cable is used to connect the QPC414 Network card to the I/O connector panel of the **QCA108** or **QCA136** cabinet.

This cable is available in the following lengths:

- **NT9J98AC**      1 m (40 in.)
- **NT9J98AD**      1.8 m (70 in.)
- **NT9J98AE**      2.2 m (85 in.)

## NT9J99 Intra-cabinet Network cable

Purpose-This cable is used to connect the **NT8D04AA** Superloop Network card to the I/O connector panel of the **QCA108** or **QCA136** cabinet.

This cable is available in the following lengths:

- **NT9J99AC**      1 m (40 in.)
- **NT9J99AD**      1.8 m (70 in.)
- **NT9J99AE**      2.2 m (85 in.)

## **QCAD1 28 connector cable**

Purpose-Connects **QPC472 DTI** Carrier Interface (J5) connector to the cabinet filter panel. It is a 15-conductor flat ribbon cable with a **15-pin** D-type female connector at one end and a **15-pin** D-type male connector at the other.

## **QCAD274A AC power cord**

Purpose-This cable conducts AC power to the **NT6D52AA** rectifier. It is 2.7 m (9 ft) long.





---

## Miscellaneous equipment

---

### Field Wiring Kit

#### System Hardware-All

**Purpose-**The NT6D54AA Field Wiring Kit is used in conjunction with the System Monitor to QBL15 cable. It provides the necessary hardware to connect four NT6D52AA rectifiers to a System Monitor.

### Blank Faceplates

#### System Hardware-All

**Purpose-**An NT7D05AA blank faceplate is required in a slot reserved for the Ringing Generator when the Ringing Generator is not in place. Although not required, other unoccupied slots can be covered by any of the following blank faceplates, depending on the width of the slot:

- 2.2 cm (0.875 in.) NT8D31AA
- 2.5 cm (1 in.) NT8D31AB

### NT8D63AA Overhead Cable Tray Kit

#### System Hardware-All

**Purpose-**Holds I/O cables that go from the system to the Main Distribution Frame (MDF). Provides support for overhead cabling tray. Mounts to the highest module in each column. Each kit consists of the following:

- support brackets
- front and rear top cap air grills with cut-outs

*Note:* This kit does not include the cable tray.

## Earthquake Bracing Kit

### System Hardware-All

Purpose-Provides a means to hold together all modules that are stacked up in vertical expansion so that in the case of an earthquake, the whole column will move as a unit. Used only for non-raised floor. Each kit contains the following:

- four threaded rods
- two tie bars
- miscellaneous hardware (nuts and washers)

Three different Earthquake Bracing Kits are available:

- two-tier NT8D64AA
- three-tier NT8D64AB
- four-tier NT8D64AC

## QRY551 Channel Service Unit

**Purpose-When** required under FCC regulations (FCC 03), provides a 24-channel digital interface between a PRI/DTI and T1 line when connecting to registered common carrier trunks.

## TELLABS 251 24-Channel Digital Echo Canceller

Purpose-For use **with** PRI/DTI when echo control is required on voice calls.

## BIX Cross-Connect System

**Purpose-The** BIX In-Building Cross-Connect System provides modular terminations and cross-connections for Meridian 1 system. (See 63 1-451 1-100 for ordering information for the BIX system and Table 5 for designation label ordering information.)



**Table 5**  
**Order Numbers for BIX Designation Labels for NT8D13 PE Modules**

Description	Color	Order number
Basic <b>500/2500</b> set labels (eight circuits per card). A set of four labels for each PE shelf is used	White	PO641 810
SL-1 set (eight circuits)	Blue	PO641 813
<b>CO/FX/WATS</b> trunk (four circuits)	Green	PO641812
<b>CO/FX/WATS</b> trunk (two circuits)	Green	<b>P0587230</b>
Loop Signaling trunk (four circuits)	Red	PO641 811
Loop Signaling trunk (two circuits)	Red	<b>P0587231</b>
<b>E&amp;M/DX</b> and Paging trunk (two circuits)	Yellow	<b>P0587233</b>
Recorded Telephone Dictation trunk (two circuits)	Orange	<b>P0587232</b>
Recorded Announcement trunk (two circuits)	Purple	<b>P0587234</b>
Four-Wire <b>E&amp;M/DX</b> Type I trunk (two circuits)	Yellow	PO631 <b>858</b> **
Four-Wire <b>E&amp;M/DX</b> Type II trunk (two circuits)	Yellow	PO631 859
Power Fail Transfer cables ( <b>P10, PFJ1, PFJ2</b> )	Yellow	PO641 814
Power Fail Transfer cables ( <b>P1 0, PFJ1</b> ) QUA6 Power Fail Transfer Unit	Yellow	PO686506
Blank labels for sets	Yellow	<b>P0588401</b>
	Blue	<b>P0588403</b>
	Silver	<b>P0588404</b>
Blank labels for trunks and riser cables	Green	<b>P0588415</b>
	Blue	<b>P0588416</b>

## Northern Telecom Publications

Northern Telecom Publications are packaged in standard Northern Telecom binders to support the various Meridian 1 systems.

Title and description	Order number
Installation and maintenance guide — System options <b>21, 51, 61, 71</b>	PO71 0530
Planning and engineering guide — System options 21, 51, 61, 71	PO71 0531
X1 1 software guide	PO71 0532
XI 1 input/output guide	PO71 0533
Special features guide	PO71 0534
Automatic Call Distribution reference guide	PO71 0535
Meridian Link general guide	PO71 0536

---

## List of terms

---

<b>ACD</b>	Automatic Call Distribution
<b>ASIM</b>	Asynchronous/Synchronous Interface Module
<b>BPS</b>	Bits Per Second
<b>BTU</b>	Bus Terminating Unit
<b>CAS</b>	Centralized Attendant Service
<b>CC</b>	Clock Controller
<b>CE</b>	Common Equipment
<b>CMA</b>	Changeover Memory Arbitrator
<b>CO</b>	Central Office
<b>CPU</b>	Central Processing Unit

<b>CRT</b>	Cathode Ray Tube
<b>DCE</b>	Data Communication Equipment
<b>DCHI</b>	D-Channel Handler Interface
<b>DID</b>	Direct Inward Dialing
<b>DTE</b>	Data Terminal Equipment
<b>DTI</b>	Digital Trunk Interface
<b>DTMF</b>	Dual Tone Multi Frequency
<b>DTR</b>	<b>Digitone</b> Receiver
<b>EIA</b>	Electronics Industry Association
<b>FDI</b>	Floppy Disk Interface
<b>FDU</b>	Floppy Disk Unit
<b>HSDC</b>	High-Speed Data Card
<b>IGS</b>	Intergroup Switch
<b>I/O</b>	Input/Output

---

<b>ISDLC</b>	Integrated Services Digital Line card
<b>ISDN</b>	Integrated Services Digital Network
<b>LRE</b>	Logic Return Equalizer
<b>MCDS</b>	Multi-Channel System
<b>MDF</b>	Main Distribution Frame
<b>MDU</b>	Multi-Disk Unit
<b>MSI</b>	Mass Storage Interface
<b>MSU</b>	Mass Storage Unit
<b>OAID</b>	Outgoing Automatic Incoming Dial
<b>OANI</b>	Outgoing Automatic Number Identification
<b>OPX</b>	Off-Premises Extension
<b>PAD</b>	Packet Assembler/Disassembler
<b>PBX</b>	Private Branch Exchange
<b>PCM</b>	Pulse Code Modulation



<b>PE</b>	Peripheral Equipment
<b>PRA</b>	Primary Rate Access
<b>PRI</b>	primary Rate <b>Interface</b>
<b>RAM</b>	Random Access Memory
<b>RAN</b>	Recorded Announcement
<b>ROM</b>	Read-Only Memory
<b>RPE</b>	Remote Peripheral Equipment
<b>SBE</b>	Segmented Bus Extender
<b>SCG</b>	System Clock Generator
<b>SDI</b>	Serial Data Interface
<b>TCM</b>	Time Compression Multiplexing
<b>TDS</b>	Tone and Digit Switch
<b>UEM</b>	Universal Equipment Module

**UPS**

**Uninterruptable** Power Supply

**3PE**

3-Port Extender

SL-1

## **System options 21, 51, 61, 71**

Equipment identification and  
ordering information

© 1990 Northern Telecom

All rights reserved.

Information subject to change without notice.

Release 1 .0

Standard

January 29, 1990

Printed in U.S.A.



---

INTEGRATED SERVICES NETWORK

# MERIDIAN . SERIES DIGITAL TELEPHONES

LINE ENGINEERING

---

## CONTENTS

CHECKLIST .....	CK 0000
ENGINEER TELEPHONE LINE .....	TP 0010
INDEX .....	IX 9999

**Note:** The module indicated by a bullet (●) in the checklist has been revised. The reason for this revision is given in the first page of the affected module.

\* MERIDIAN is a trademark of Northern Telecom







Vertical text or markings along the left edge of the page, possibly a page number or header.

Faint, illegible text at the bottom of the page, possibly bleed-through from the reverse side.

Page 1 of 10	0010
553-2201-180	TP
Standard	86 06 05

## NOTES

Note: This module is reissued ~~to~~ change the minimum loop length requirement to 100 ft, and to add metric equivalents.

- (1) Cable pair selections must meet the following requirements:
- AC signal loss must be **less** than 12.9 **dB** at 256 **kHz** due to all sources
  - **DC** loop resistance must be less than 175 Ohm
  - Minimum loop length (mainframe bulkhead to telephone) of 30 m (100 ft)
  - Near end crosstalk coupling loss **>38 dB** at **Nyquist** frequency of 256 **kHz** (not an issue for typical 22, 24, and 26 AWG twisted pair cable)
  - No bridge taps are permitted
  - No loading coils are permitted
  - Protection devices of the carbon-block and gas-filled type are permitted if the off-state shunting impedance is better than 10 **Megohm** resistive, and less than **0.5-pF** capacitive.
- (2) The following criteria have to be met where undercarpet cabling is used.
- characteristic impedance at 256 **kHz**, **100 ± 10 Ohm**
  - insertion loss at 256 **kHz**, **< 4.6 dB/kft.**
  - next pair-to-pair coupling loss at 256 **kHz**, **> 40 dB**
- (3) For the typical system of 22, 24, or 26 AWG standard twisted pair cable, the requirements translate to the following allowable loops.
- up to 915 m (3000 ft) of 22 or 24 AWG cable
  - up to 640 m (2100 ft) of 26 AWG cable
- (4) If selected cable pair does not work satisfactorily, select another cable pair using the following flowchart (Page 2):



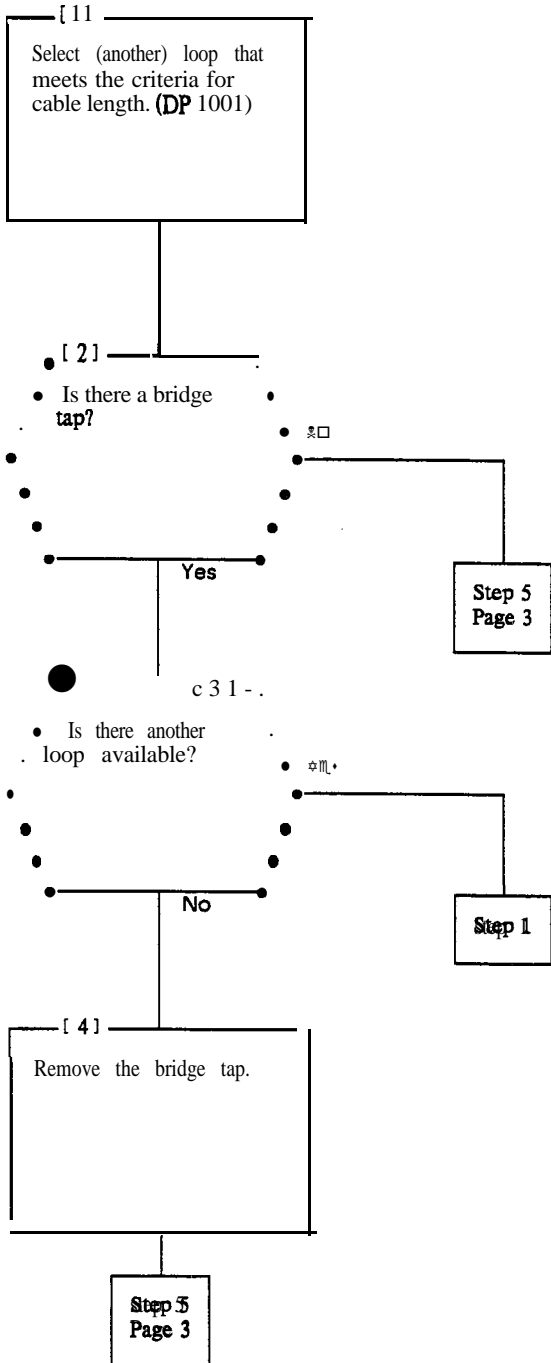

Page 3 of 10	0010
553-2201-180	TP
Standard	86 06 05

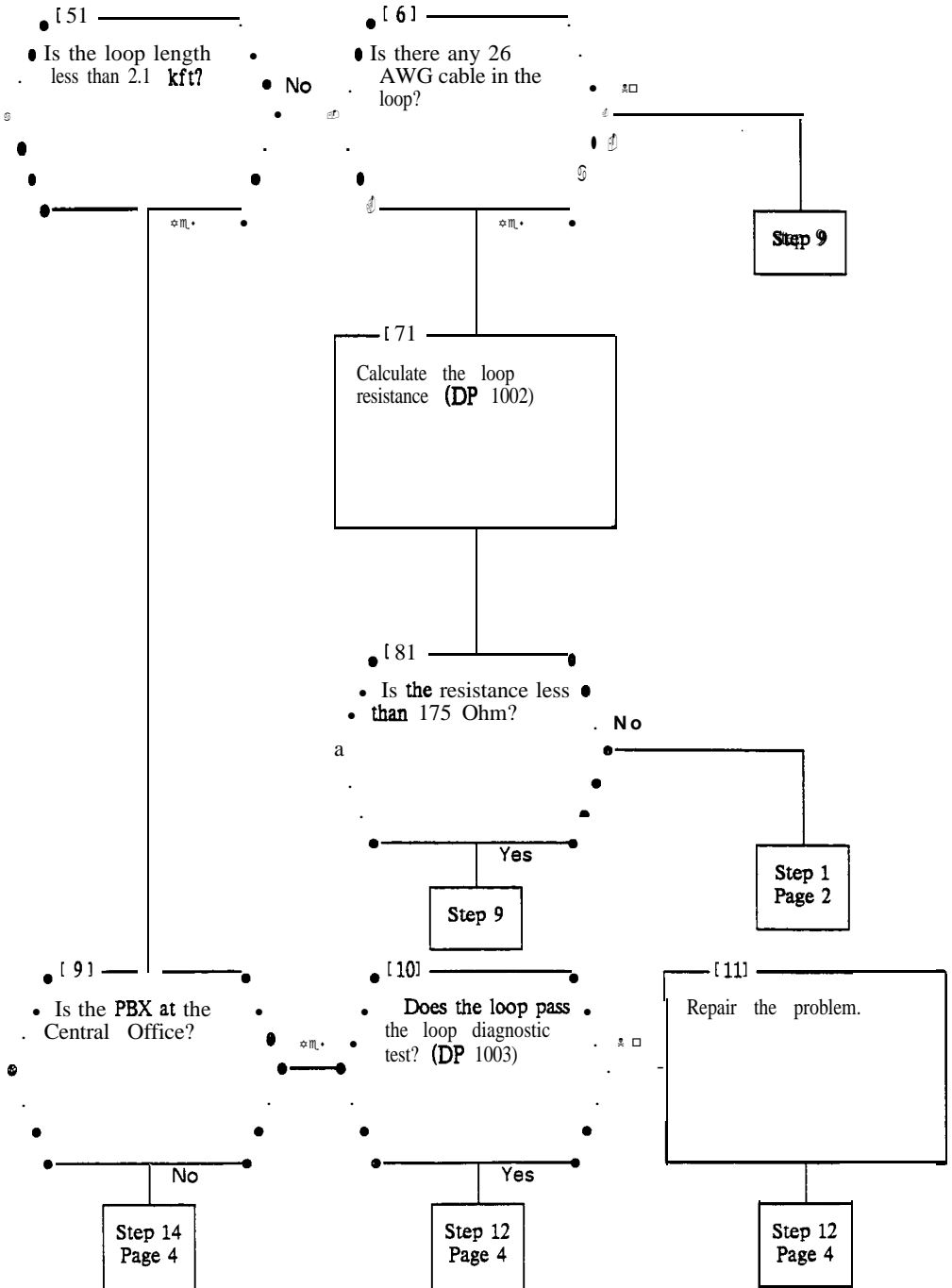

ENGINEER of 10 E	0010 E
553-2201-180	TP
Standard	86 06 05

P H O N E L I N E

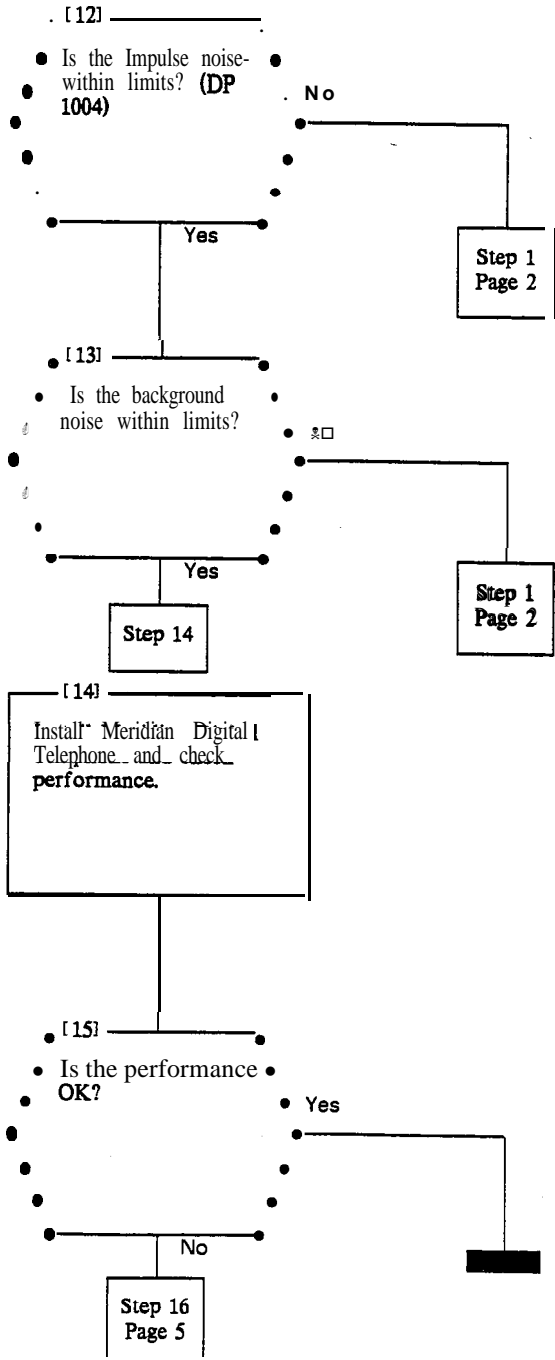

Page 5 of 10	0010
553-2201-180	TP
Standard	86 06 05

[161] \_\_\_\_\_

Is there another pair available?

No

Step 18

Yes

[17] \_\_\_\_\_

Is this the second time around?

No

Step 1  
Page 2

Yes

[18]

Collect more detailed loop data and calculate EPL (DP 1006)

[19] \_\_\_\_\_

Is EPL less than 12.0 dB?

No

Step 27  
Page 8

Yes

Step 20  
Page 6

Page 6 of 10	0010
553-2201-180	TP
Standard	86 06 05

## ENGINEER TELEPHONE LINE

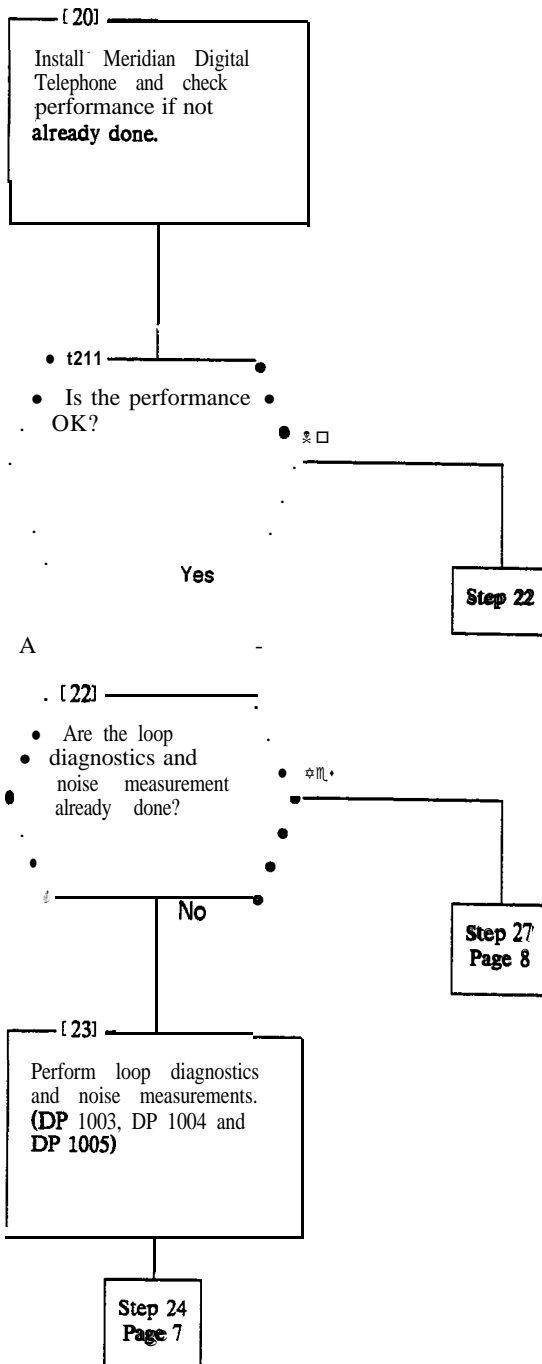

Page 7 of 10	0010
553-2201-180	TP
Standard	86 06 05

[24] \_\_\_\_\_

• Are impulse noise  
and background  
noise within limits?

No

Step 27  
Page 8

[25] \_\_\_\_\_

• Is the problem  
fixed?

Yes

Step 27  
Page 8

[26] \_\_\_\_\_

• Is the performance  
OK?

Yes

Step 27  
Page 8

E Page 6 of 110 N	E001B	R
553-2201-180	TP	
Standard	86 06 05	

TELEPHONE L I N E

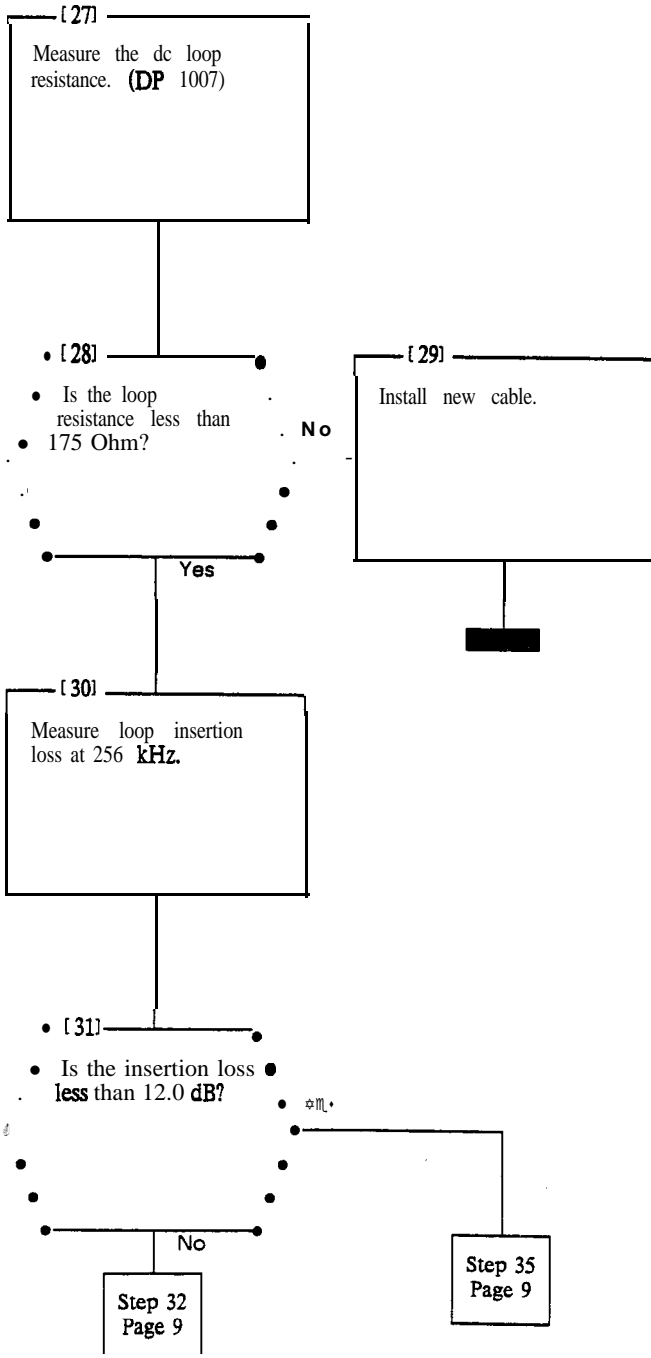

Page 9 of 10	0010
553-2201-180	TP
Standard	86 06 05

[ 32 ]  
Replace any under-carpet cable if insertion loss can be reduced.

[ 33 ]  
Install Meridian Digital Telephone and check **performance.**

[ 34 ]  
● Is the performance ●  
OK?

[ 35 ]  
At this point there may be other problems as listed in Table 0010-A

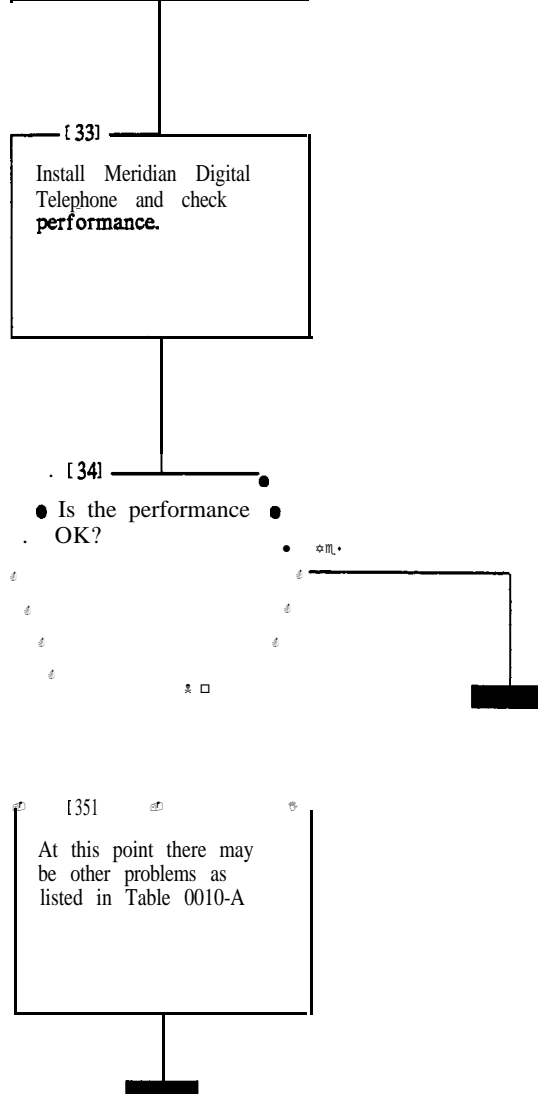



E Page 19 of 110 N	E010
553-2201-180	TP
Standard	86 06 05

R TELEPHONE L I N E

Table 0010-A  
POSSIBLE FAULTS

---

- EMI
  - Unrecorded bridge taps
  - Under-carpet cable
  - Split cable pairs
  - Impulse noise - not recorded due to speed limitations of the impulse counter.
  - Faulty telephone
-

**SELECT A LOOP**

Page 1 of 1	1001
553-2201-180	DP
Standard	86 01 27

**NOTES**

0.01 The requirements for a Meridian Digital Telephone are that the loop be without bridge taps, and be less than 175 Ohm dc resistance, and less than 12.0 dB loss at 256 kHz. For a single gauge cable, the length limits are 3000 ft for 22 and 24 AWG cable and D inside wiring, and 2100 ft for 26 AWG cable.

0.02 The allowable loop length assumes that there is no under-carpet cable. If there is under-carpet cable of a type that is different from Western Electric 4-pair cable, reduce the allowable loop length using the following equation:

$$LM = 112 - (UC \times UL) / LL$$

where

LM = loop length limit in km (kft) (excluding the length of the under-carpet cable).

LL = loop loss in dB/km (dB/Kft) at 256 kHz.

UC = length of the under-carpet cable in km (kft).

UL = loss of the under-carpet cable in dB/km (dB/kft) at 256 kHz. Refer to Table 1006-B for dB-values.



# CALCULATE DC LOOP RESISTANCE

Page 1 of 2	1002
553-2201-180	DP
Standard	86 01 27

## Chart 1002-I CALCULATE DC LOOP RESISTANCE

---

STEP	PROCEDURE
------	-----------

---

- 1 Calculate the dc loop resistance by adding the resistance of each cable section. Calculate the resistance of each cable section using the following formula (Cable resistances are given in Table 1002-A.):

$$LR_i = CR_i \times SL_i$$

where:

- $LR_i$  = dc resistance for cable section "i"
  - $CR_i$  = conductor resistance per unit length for the cable section "i"
  - $SL_i$  = length of cable section "i"
- 2 Add the total of all cable sections. If the total of all sections exceeds 175 Ohm, select another loop.

Note: The loop resistance limit of 175 Ohm must be reduced by 1 Ohm for each 1% of the loop which is aerial cable.

---

Page 2 of 2	1002
553 2201 180	DP
Standard	86 01 27

CALCULATE DC LOOP RESISTANCE

Table 1002-A  
CONDUCTOR RESISTANCE PER UNIT

Gauge	Ohm per loop kft	Ohm per loop km
26		
24	111	278
22	33	109
19	16	54



Page 1 of 2	1003
553-2201-180	DP
Standard	86 01 27

Chart 1  
PERFORM LOOP DIAGNOSTIC TESTS

---

## APPARATUS:

- 1 Volt-Ohmmeter (VOM)
  - 1 77 Cable Analyser or equivalent
- 

---

**STEP PROCEDURE**

---

**FOREIGN VOLTAGE TEST**

- 1 Set the VOM range switch to a scale 60 Vdc/Vac or more.
- 2 Connect the VOM test probes to the loop at the line card or distributing frame.
- 3 Measure the dc and ac voltage between the following points under no-load conditions.
  - T and R
  - T and GND
  - R and GND

**Requirement:** Voltage readings should be less than 1 Vdc/Vac.

**INSULATION RESISTANCE TEST**

- 1 Set the VOM range switch to OhmX10.000 and adjust the meter to zero.
- 2 Connect the VOM test probes to the loop at the line card or distributing frame.
- 3 Measure the resistance between the following points under no-load conditions.
  - T and R
  - T and GND
  - R and GND

**Requirement:** Resistance readings should be greater than 10 MOhm.

**DC CONTINUITY TEST**

- 1 Short circuit the T and R at the far end.
- 2 Using the VOM, measure the resistance between the T and R.

**Requirement:** Resistance measurement should be approximately equal to the calculated loop resistance per DP1002.

Page 2 of 2	1003
553-2201-180	DP
Standard	86 01 27

## PERFORM LOOP DIAGNOSTIC TESTS

Chart 1 Continued

### PERFORM LOOP DIAGNOSTIC TESTS

---

#### STEP PROCEDURE

---

#### CAPACITANCE UNBALANCE TEST

- 1 Using the 77 Cable Analyser or equivalent, measure the capacitance between the following points:
  - T and GND
  - R and GND

**Requirement:** Difference between the two readings should be  $<0.002$  microfarads.

---

Page 1 of 2	1004
553-2201-180	DP
Standard	86 01 27

Chart 1004-I  
MEASURE IMPULSE NOISE

---

**STEP PROCEDURE**

---

- 1 Measure impulse noise on selected lines during busy hours. Use an NE-58B Noise measurement set, or equivalent.

**Note:** The termination and weighting filter required are 135 Ohm and 100 kHz respectively, and the blanking interval 25 microseconds.

- 2 Using Figure 1004-L Determine that for a given loop loss and noise threshold, the impulse noise counts per 15 minutes are below the corresponding curve.

**Note:** The values in Figure 1004-I were derived assuming the counter has a count rate of 512 pulses per second.

**Note:** Due to the inaccuracy of the Noise Measuring Set, it is possible that additional errors may occur during the blanking interval and the reading will consequently be lower than actual.

---



MEASURE IMPULSE NOISE

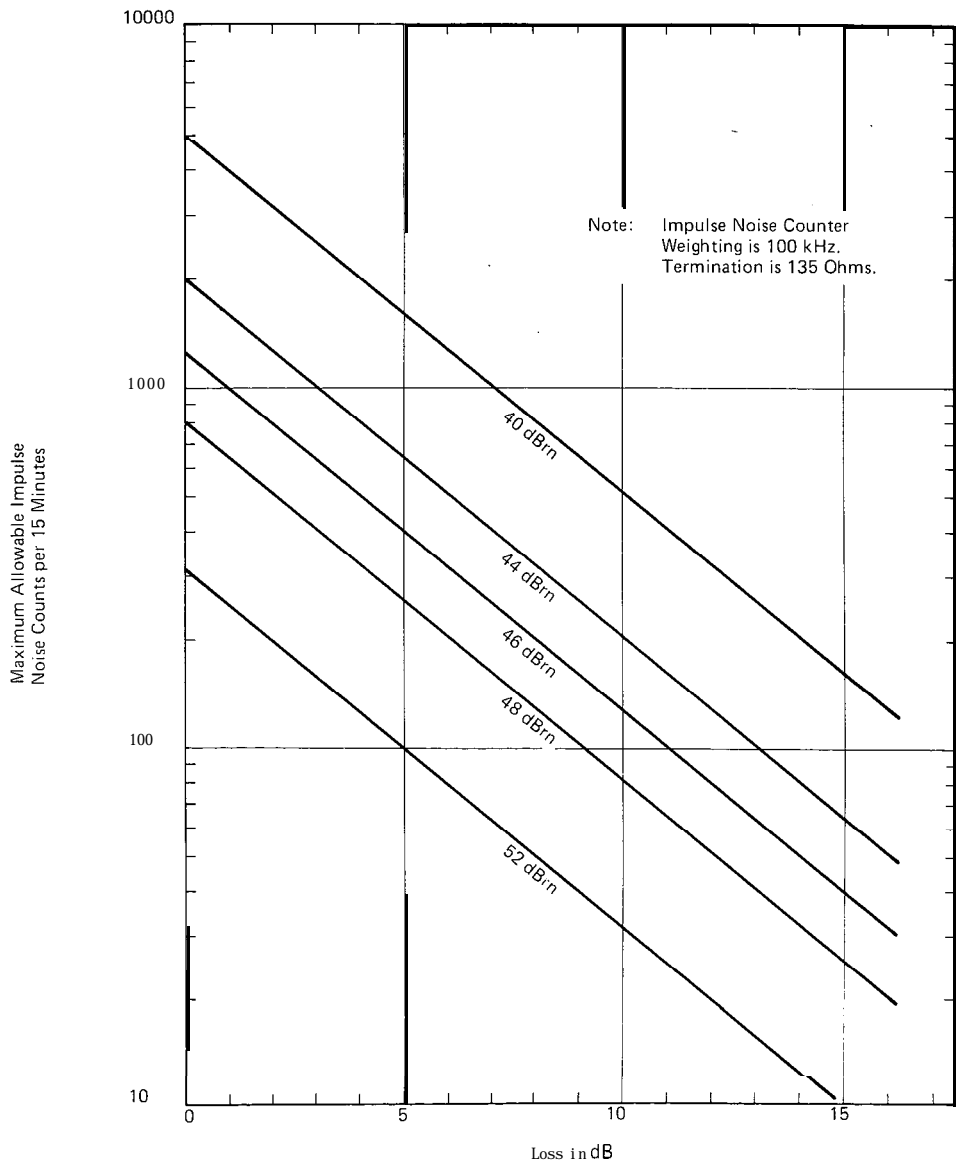

Fig. 1004-I  
Maximum Allowable Impulse Noise Counts Versus Loop Loss

MEASURE BACKGROUND NOISE

Page 1 of 1	1005
553-2201-180	DP
Standard	86 01 27

Chart 1005-I  
MEASURE BACKGROUND NOISE

---

STEP PROCEDURE

---

- 1 Measure background noise on the loop using an **NE-58B** noise measuring set.

**Note:** The weighting and termination to be used are 100 kHz flat and 135 Ohm respectively.

- 2 Reject the loop being tested if the background noise measured is not less than **51dBrn**.
-



Page 1 of 4	1006
553-2201-180	DP
Standard	86 01 27

**Chart 1006-I**  
**COLLECT LOOP MAKEUP DATA AND CALCULATE EPL**  
**(EXPECTED PULSE LOSS)**

---

**STEP PROCEDURE**

---

- 1 Collect loop makeup data between the line card and the terminal, For each cable section, the data required is:
  - the cable type (PIC or pulp)
  - gauge
  - length
  - type of plant construction (underground, aerial, inbuilding)

Calculate individual cable section losses using the figures in Tables 1006-A, 1006-B, 1006-C, and the following equation.

$$CSL_i = SL_i \times L_i$$

- $CSL_i$  = cable section loss for section "i".
- $SL_i$  = section length of section "i".
- $L_i$  = loss per unit length for section "i".

- 3 Correct individual cable section losses for maximum cable temperature using the following equation.

$$TCL_i = CSL_i \times TCF_i$$

- $TCL_i$  = temperature corrected loss for section "i"
- $TCF_i$  = temperature correction factor for section "i"

**CORRECTION FACTORS**

Aerial Cable TCF = 1.1

Underground cable TCF = 1.04

Inbuilding cable TCF = 1

- 4 Determine junction loss. (Figure 1006-I)

**Note:** Junction loss due to gauge discontinuity of outside plant cables and D-inside wire varies between 0.03 dB and 0.07 dB and can be ignored. However, AMP 25-pair under-carpet wiring has a characteristic impedance of 40 Ohm at 256 kHz and its junction loss is approximately 2 dB. This must be included in the calculation.

- 5 Calculate the EPL by finding the sum of the above items.

Page 2 of 4	1006
553-2201-180	DP
Standard	86 01 27

COLLECT LOOP MAKEUP DATA AND CALCULATE EPL

Chart 1006-I Continued  
 COLLECT LOOP MAKEUP DATA AND CALCULATE EPL  
 (EXPECTED PULSE LOSS)

---

**STEP PROCEDURE**

---

6 Reject loops whose expected pulse loss is not less than 12.0 dB.

**EXAMPLE**

**Section 1:**

Mainframe bulkhead to DF1 = 500m. 26 AWG PIC, underground

**Section 2:**

DF1 to DF2 = 200m, 26 AWG PIC, inside

**Section 3:**

DF2 to terminal = 24 AWG NT D-inside

**Therefore:**

SL1 = 0.5km, SL2 = 0.2km, SL3 = 0.1km

**From Tables 1006A and 1006C:**

L1 = 13.7 dB/km. L2 = 13.7 dB/km. L3 = 13.3 dB/km.

**Using the equation in Step 2 we arrive at:**

CSL1 = 6.85 dB, CSL2 = 2.74 dB, and CSL3 = 1.33 dB

**Temperature Corrections:**

Using correction factors of TCF1 = 1.04. TCF2 and TCF3 = 1, and using the equation in Step 3 results in TCL1 = 7.12 dB. TLC2 = 2.14 dB, and TCL3 = 1.33 dB.

**EPL Value:**

Neglecting any junction loss per explanation in Step 4.

Step 5 results in an EPL value of:

TSL1 + TSL2 + TSL3 + 0 = 11.19 dB.

This is under the 12 dB limit and meets the criteria.

---

Page 3 of 4	1006
553-2201-180	DP
Standard	86 01 27

Table 1006-A  
CABLE ATTENUATION AT 256 KHZ AND 21.1 °C (70° F)

	26 AWG		24 AWG		22 AWG		19 AWG	
	dB/kft	dB/km	dB/kft	dB/km	dB/kft	dB/km	dB/kft	dB/km
PIC	4.2	13.7	3.1	10.2	2.5	8.1	1.7	5.6
PULP	4.3	14.3	3.5	11.4	2.1	9.0	2.0	6.6

Table 1006-B  
ATTENUATION AT 256 KHZ FOR U/C CABLE

	WE 4 pairs		AMP 25 pair	
	dB/kft	dB/km	dB/kft	dB/km
	3.6	15.3	19.0	63.3

Table 1006-C  
ATTENUATION AT 256 KHZ FOR D INSIDE WIRING CABLE

	NT		WE		SUPERIOR		GENERAL	
	dB/kft	dB/km	dB/kft	dB/km	dB/kft	dB/km	dB/kft	dB/km
	4.0	13.3	3.2	10.7	3.1	13.3	4.6	15.3

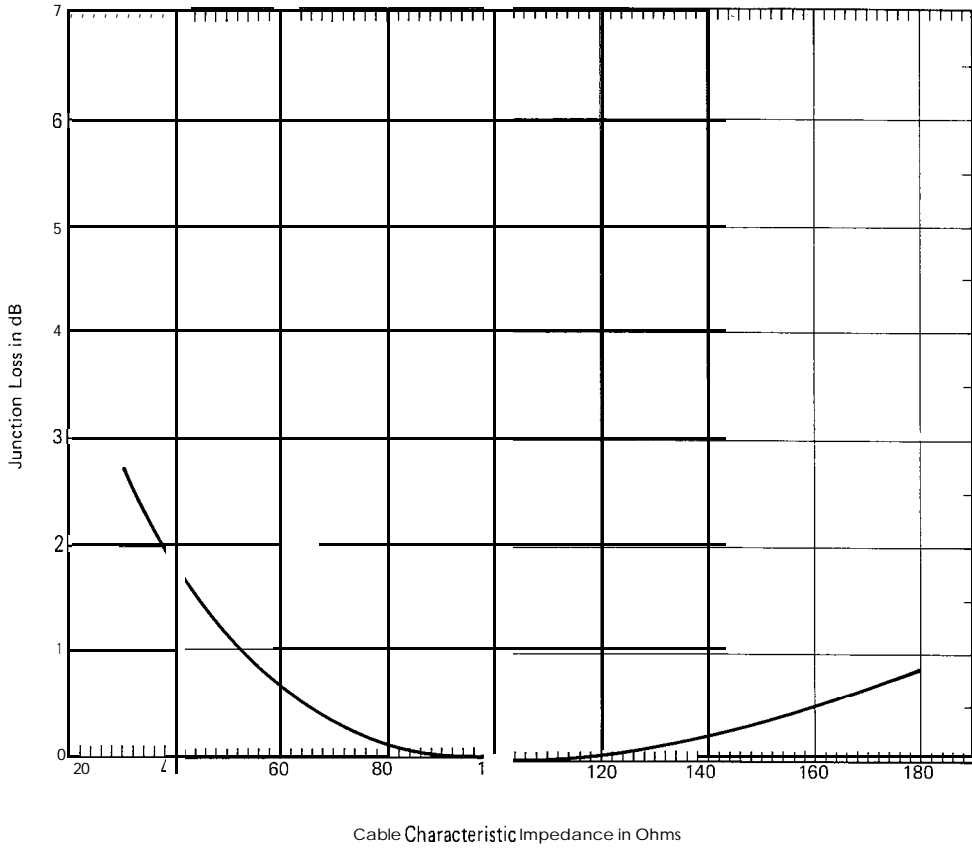

(III. 06440)

**Fig. 1006-1**  
**Junction Loss vs Cable Characteristic Impedance**

# MEASURE DC LOOP RESISTANCE

Page 1 of 1	1007
553-2201-180	DP
Standard	86 01 27

## Chart 1007-I MEASURE LOOP RESISTANCE

---

### STEP PROCEDURE

---

- 1 Measure loop resistance using standard procedures.

**Note:** The dc loop resistance limit of 175 Ohm should be reduced by 1 Ohm for each 1% of the total loop that is aerial cable.

---





—



INDEX

Page 1 of 1	9999
553-2201-180	IX
Standard	86 01 27

TITLE	PROCEDURE NUMBER
CALCULATE DC LOOP RESISTANCE	DP 1002
CHECKLIST	<b>CK 0000</b>
COLLECT LOOP MAKEUP DATA AND CALCULATE <b>EPL</b>	DP 1006
ENGINEER TELEPHONE LINE	TP 0010
INDEX	Ix 9999
MEASURE BACKGROUND NOISE	DP <b>1005</b>
MEASURE DC LOOP RESISTANCE	DP 1007
MEASURE IMPULSE NOISE	DP 1004
PERFORM LOOP DIAGNOSTIC TESTS	<b>DP 1003</b>
SELECT A LOOP	DP 1001



1



---

**INTEGRATED SERVICES NETWORK**
**MERIDIAN SL-1\***
**SUMMARY OF TRANSMISSION PARAMETERS**

---

<b>CONTENTS</b>	<b>PAGE</b>
1. u-LAW TRANSMISSION PARAMETERS	1-1
2. A-LAW TRANSMISSION PARAMETERS	2-1
3. D T I L O S S T A B L E S	3 - 1

**Tables**

1-A Insertion Loss at 1020 Hz ("Connections Between Analog Ports) .....	1-1
1-B Frequency Response (Amplitude Distortion)	1-1
1-C Overload Levels .....	1-2
1-D Tracking (Linearity) .....	1-2
1-E Transhybrid Loss .....	1-2
1-F Input Impedance .....	1-3
1-G Idle Channel Noise .....	1 - 3
1-H Longitudinal Balance .....	1-3
1-I Impulse Noise .....	1-4
1-J Intermodulation Distortion .....	1-4
1-K Envelope Delay Distortion .....	1-4
1-L Quantization Distortion .....	1-5
1-M Crosstalk .....	1 - 5
1-N Return Loss (Design Requirements)	1-5
1-o Return Loss (In-Service Requirements) .....	1-6
1-P Harmonic Distortion .....	1-6
2-A Insertion Loss At 820 Hz .....	2 - 1
2-B Maximum Inband Amplitude Distortion .....	2-1
2-c Return Loss (Design Requirements) .....	2-2
2-D Return Loss (In-Service Requirements) .....	2-3
2-E Distortion and Modulation Products .....	2-4
2-F Linearity .....	2-4
2-G Envelope Delay Distortion .....	2-5
2-H Crosstalk .....	2-5
2-J Overload Levels .....	2-5
2-K Message Circuit Noise .....	2-6
2-L Impulse Noise .....	2-6
2-M Longitudinal Balance .....	2-6
2-N Quantization Distortion .....	2 - 7

\*MERIDIAN and SL-1 are trademarks of Northern  
Telecom Limited

CONTENTS	PAGE
3 - A 1000 Hz Insertion Loss for Connections between an Analog Port and a Digital Trunk Interface (DTI) Port	3-2
3-B 1000 Hz Insertion Loss for Connections' between Two Ports of a Digital Trunk interface (DTI)	3-3
3 - c 1000 Hz Insertion Loss for Connections between an Analog Port and a Digital Trunk Interface (DTI) Port for Connections to a Satellite PBX	3-4
3 - D 1000 Hz Insertion Loss for Connections between Two Ports of a Digital Trunk Interface (DTI) for Connections to a Satellite PBX	3-6

**Reason for Reissue:** This practice is reissued to include transmission parameters for the Digital Trunk Interface, and to revise and add LO the parameters for the Meridian SL-1. Changes have been marked with bracketing arrows and arrowheads.

**1.  $\mu$ -LAW TRANSMISSION PARAMETERS**

1.01 The tables in this part provide the transmission requirements which Meridian SL-1 is designed to meet or exceed in  $\mu$ -Law applications. The specified performance applies in the temperature range of 0 to 50° C.

1.02 Unless otherwise specified, all specifications are stated in terms of being met by 95% of connections.

**Table 1-A**  
**INSERTION LOSS AT 1020 Hz (Connections Between Analog Ports)**

TYPE OF CONNECTION	NOMINAL INSERTION LOSS (dB)	LOSS VARIATION (dB)
Line-to-Line	5	± 1.0
Line-to-Trunk	1	± 0.7
Trunk-to-Trunk	1	± 0.7

**Note:** The above loss values apply to connections between analog ports. Port-to-port losses for connections involving a Digital Trunk Interface (DTI) port are given in Part 3.

**Table 1-B**  
**FREQUENCY RESPONSE (AMPLITUDE DISTORTION)**

Frequency Response in dB at the specified frequencies (Hz) for line-to-line, line-to-trunk, or trunk-to-trunk connections.

60 Hz		200 Hz		300 Hz		3000 Hz		3200 Hz		3400 Hz	
MIN	MAX	MIN	MAX	MIN	MAX	MIN	MAX	MIN	MAX	MIN	MAX
+20	-	0.0	+5.0	-0.5	+1.0	-0.5	+1.0	-0.5	+1.5	0.0	+3.0

**Note:** Values are stated relative to loss at 1000 Hz. The symbol + denotes more loss; the symbol - denotes less loss than that measured at 1000 Hz.

Table 1-C  
OVERLOAD LEVELS

TYPE OF CIRCUIT	NOMINAL OVERLOAD LEVEL (dBm)	
	RECEIVE (A/D)	TRANSMIT (D/A)
Line	+7	+2
Trunk	+3	+6

**Note:** Receive and Transmit relate to Switch.

Table 1-D  
TRACKING (LINEARITY)

	INPUT SIGNAL (dB) BELOW OVERLOAD	TRACKING ERROR (dB)	
		MAXIMUM	AVERAGE
→	+3 to -40	±0.5	±0.25
→	-40 to -53	±1.0	±0.5

**Note 1:** Signal at 1020 Hz.  
**Note 2:** Maximum specification for 99% of all connections.

Table 1-E  
TRANSHYBRID LOSS

TWO-WIRE PORT	TRANSHYBRID LOSS (dB)	
	200 to 3400 Hz	500 to 2500 Hz
Line	>17	>19
Trunk	>18	>21

**Note 1:** This parameter is for EIA-compatible trunks only.  
**Note 2:** Measurement of transhybrid loss (THL) is made from equal-level (transmit and receive) four-wire port towards the two-wire port.  
**Note 3:** Two-wire port compromise impedance: 600 Ω or 350 Ω in series with 100 Ω, 0.21 μF.

**Table 1-F  
INPUT IMPEDANCE**

CONNECTION FROM 4W TRUNK TO PORT	REFERENCE IMPEDANCE	FREQUENCY RANGE	MINIMUM RETURN LOSS
Line	600 Ω	200-500 Hz	20 dB
		500-3400 Hz	26 dB
Trunk	600 Ω	200-500 Hz	20 dB
		500-1000 Hz	26 dB
		1000-3400 Hz	30 dB

**Note 1:** This parameter is for EIA-compatible trunks only.

**Note 2:** A reference impedance of 600 Ω resistive is used.

**Table 1-G  
IDLE CHANNEL NOISE**

CONNECTION TYPE	C-MESSAGE WEIGHTED (dBrnC)	3 kHz FLAT (dBrn)
Line-Line	<20	<29
Line-Trunk	<20 at line <23 at trunk	<29 at line <29 at trunk
Trunk-Trunk	<20	<29

**Table 1-H  
LONGITUDINAL BALANCE**

FREQUENCY (Hz)	MINIMUM BALANCE (dB)	AVERAGE BALANCE (dB)
200	58	63
500	58	63
1000	58	63
3000	53	58

**Note:** Measured according to IEEE Standard 455-1983.



**Table 1-I  
IMPULSE NOISE**

CONNECTION	NUMBER OF COUNTS ABOVE 55 dBmC
All	0

**Note:** For test purposes, a five-minute counting interval is used.

**Table 1-J  
INTERMODULATION DISTORTION**

CONNECTION TYPE	DISTORTION LIMITS (dB BELOW RECEIVED LEVEL)		TEST SIGNAL INPUT LEVEL
	R2	R3	(dBm)
Line-to-Line	40	43	- 9
Line-to-Trunk	45	53	-9 at line -13 at trunk
Trunk-to-Trunk	45	53	-13

**Note 1:** Four-tone method is used.

**Note 2:** Test Signal Input Level is the composite power level of all four tones.

**Table 1-K  
ENVELOPE DELAY DISTORTION**

BANDWIDTH (Hz)	ENVELOPE DELAY DISTORTION (μs) LINE-LINE	ENVELOPE DELAY DISTORTION (μs) LINE-TRUNK/ TRUNK-TRUNK
800 to 2700	750	375
1000 to 2600	380	190
1150 to 2300	300	150

**Table 1-L  
QUANTIZATION DISTORTION**

INPUT LEVEL BELOW OVERLOAD	SIGNAL/DISTORTION RATIO (dB)
+3 to -33	33
-33 to -43	27
-43 to -48	22

**Note:** Input signal is 1 kHz sinewave; output measured with C-message weighting. (See Table 1-C for overload definition.)

**Table 1-M  
CROSSTALK**

CONNECTION	MINIMUM CROSSTALK ATTENUATION (dB)
Line-to-Line	>75
Line-to-Trunk	>75
Trunk-to-Trunk	>75

**Note:** Input frequency range of 200 to 3200 Hz, 0 dBm level.

**Table 1-N  
RETURN LOSS (Design Requirements)**

CONNECTION	ECHO RETURN LOSS (dB)	SINGING RETURN LOSS (dB)
Line Interfaces:		
Line Side (Note)	>18	>12
4W Trunk Side (Note)	>25	>19
2W Trunk Interfaces:		
2W Trunk Side (Note)	>22	>17
4W Trunk Side (Note)	>28	>22

The design requirements in this table are intended to ensure the satisfaction of the in-service requirements in Table 1-0.

**Note:** Terminating impedances are:  
 - 600Ω for SL-1 line  
 - 600Ω for PBX line.

**Table 1-O**  
**RETURN LOSS (In-Service Requirements)**

CONNECTION FROM 4W VNL TIE TRUNK TO THE FOLLOWING:	CIRCUIT TERMINATION	ECHO RETURN LOSS	LOW/HIGH SINGING RETURN LOSS	NOTES
4W VNL Tie Trunk (through balance)	4W legs of Hybrid terminated in 600/900Ω	27	20/20	1.3
4W Non-VNL Tie Trunk (terminal balance)	600/900Ω + 2.16 μF at distant PBX	22	15/15	1.3
2W Non-VNL Tie Trunk (terminal balance)	600/900Ω + 2.16 μF at distant PBX	18	10/10	1.5
CO or FX Trunk (terminal balance)	900R + 2.16 μF at c o	18	10/10	2.5
PBX Station Line (terminal balance)	600Ω + 2.16 μF	24	18/18	1.4
SL-1 Station Line (terminal balance)	600Ω	24	18/18	1.4
PBX Station Line (terminal balance)	Station off-hook	12	8/8	1.4

**Note 1:** Reference impedance is 600/900Ω + 2.16 μF.

**Note 2:** Reference impedance is 900Ω + 2.16 μF.

**Note 3:** Switchable pads set for nominal loss of 1 dB.

**Note 4:** Switchable pads set for nominal loss of 3 dB.

**Note 5:** If facility loss is less than 2 dB or adequate impedance correction is not provided, nominal loss has to be increased to 3 dB by switching in the 2 dB pad.

**Table 1-P**  
**HARMONIC DISTORTION**

	BANDWIDTH (Hz)	MAX. LEVEL OF DISTORTION PRODUCT (dB)	TEST SIGNAL INPUT LEVEL (dBm)
4	200 to 4600	≥ 28	0

2. A-LAW TRANSMISSION PARAMETERS

2.01 The tables in this part provide the transmission requirements which Meridian SL-1 is designed to meet on 95% of all connections in A-Law applications.

Table 2-A  
INSERTION LOSS AT 820 HZ

TYPE OF CONNECTION	NOMINAL INSERTION LOSS (dB) at 25°C	MAXIMUM INSERTION LOSS (dB) at 0° to 50°C	MINIMUM INSERTION LOSS (dB) at 0° to 50°C
Station line-to-line	5	6	4
Station line-to-trunk	1	2	0
Trunk-to-trunk	1	2	0

Table 2-B  
MAXIMUM INBAND AMPLITUDE DISTORTION

CONNECTION	AMPLITUDE DISTORTION (dB) 0.2 kHz		DISTORTION (dB) 3.4 kHz	
	MIN	MAX	MIN	MAX
Line-to-line	-0.5	3.5	0.0	3.5
Trunk-to-trunk	0.0	3.0	0.0	3.0
Trunk-to-line	0.0	4.0	0.0	3.0

**Note:** Performance limits quoted apply to 95% of all connections.

**Table 2-C**  
**RETURN LOSS (Design Requirements)**

CONNECTION	ECHO RETURN LOSS (dB)	SFRL LOSS (dB) (300-3200 Hz)
Line Interfaces:		
Line Side (Note 1)	$\geq 18$	$\geq 12$
4W Trunk Side (Note 2)	$\geq 21$	$\geq 19$
2W Trunk Interfaces:		
2W Trunk Side (Note 2)	$\geq 22$	$\geq 14$
4W Trunk Side (Note 2)	$\geq 21$	$\geq 19$
<p>The design requirements in this table are intended to ensure the satisfaction of the in-service requirements in Table 2-D.</p>		
<p><b>Note 1:</b> Terminating impedances are:</p>	<ul style="list-style-type: none"> <li>- 600Ω for SL-1 line</li> <li>- 600Ω and 2.16 μF for PBX.</li> </ul>	
<p><b>Note 2:</b> Terminating impedances are:</p>	<ul style="list-style-type: none"> <li>- 600Ω for SL-1 line</li> <li>- 600 or 900Ω and 2.16 μF for PBX line.</li> </ul>	

**Table 2-D**  
**RETURN LOSS (In-Service Requirements)**

CONNECTION FROM 4W VNL TIE TRUNK TO THE FOLLOWING:	CIRCUIT TERMINATION	ECHO RETURN LOSS	LOW/HIGH SINGING RETURN LOSS	NOTES
4W VNL Tie Trunk (through balance)	4W legs of Hybrid terminated in $600\Omega$	27	20/20	1,3 ←
4W Non-VNL Tie Trunk (terminal balance)	$600R \cdot k$ $2.16 \mu F$ at distant PBX	22	15/15	1.3 ←
2W Non-VNL Tie Trunk (terminal balance)	$600\Omega + 2.16 \mu F$ at distant PBX	18	10/10	1.5
CO or FX Trunk (terminal balance)	$900R + 2.16 \mu F$ at c o	18	10/10	2.5
PBX Station Line (terminal balance)	$600\Omega + 2.16 \mu F$	24	18/18	1,4
SL-1 Station Line (terminal balance)	$600\Omega$	24	18/18	1,4
PBX Station Line (terminal balance)	Station off-hook	12	8/8	1,4

**Note 1:** Reference impedance is  $600/900\Omega + 2.16 \mu F$ .

**Note 2:** Reference impedance is  $900\Omega + 2.16 \mu F$ .

**Note 3:** Switchable pads set for nominal loss of 1 dB.

**Note 4:** Switchable pads set for nominal loss of 3 dB.

**Note 5:** If facility loss is less than 2 dB or adequate impedance correction is not provided, nominal loss has to be increased to 3 dB by switching in the 2 dB pad.

**Table 2-E  
DISTORTION AND MODULATION PRODUCTS**

DISTORTION TYPE	INPUT LEVEL (dB) BELOW OVERLOAD	INPUT FREQUENCY/s (Hz) (excluding submultiples of 8 kHz)	MAXIMUM LEVEL OF DISTORTION PRODUCT
Harmonic	3	700-1100	≥ 40 dB below fundamental output signal
Intermodulation	13	300-3400 (see Note)	≥ 35 dB below fundamental output signal
Sideband Suppression	3	700-1100	≥ 40 dB below fundamental output signal
Quantization	0-33	700-1100	≥ 33 dB
	33-43	700-1100	≥ 27 dB
	43-48	700-1100	≥ 22 dB

**Note:** Using two oscillators, each with an output impedance of 1200/1800Ω.

**Table 2-F  
LINEARITY**

820 Hz SIGNAL INPUT LEVEL (dB) BELOW OVERLOAD	VARIATION IN INSERTION LOSS (dB)
0 to 43	±0.5
43 to 53	±1
53 to 58	±3

**ENVELOPE DELAY DISTORTION**

BANDWIDTH (Hz)	ENVELOPE DELAY DISTORTION ( $\mu$ s)	
	LINE-LINE	LINE-TRUNK/ TRUNK-LINE/ TRUNK-TRUNK
1000 to 2600	380	190
1150 to 2300	300	150
800 to 2700	750	375

**Note:** The limits above apply to 95% of all connections.

**Table 2-H  
CROSSTALK**

CONNECTION	CROSSTALK ATTENUATION (dB)
Line-to-Line	>75
Line-to-Trunk	>75
Trunk-to-Trunk	>75

**Note:** Frequency range of test signal 0.2 to 3.4 kHz at -10 dBm.

**Table 2-J  
OVERLOAD LEVELS**

TYPE OF CIRCUIT	NOMINAL OVERLOAD LEVEL (dBm)	
	TRANSMIT	RECEIVE
Line	+7	+2
Trunk	+3	+6



**Table 2-K  
MESSAGE CIRCUIT NOISE**

CONNECTION	NOISE LEVEL	
	dBm0p	dBm 3 kHz FLAT
Line-to-Line	≤ -65	≤ 29
Line-to-Trunk:		
(a) Trunk side	≤ -65	≤ 29
(b) Line side	≤ -65	≤ 29
Trunk-to-Trunk (2 dB pads out)	≤ -65	≤ 29

**Table 2-L  
IMPULSE NOISE**

With all circuits at the MDF correctly terminated, the impulse noise measured at line terminals should be as follows.

NOISE LEVEL (dB)	COUNTS
50	<5 counts/S min for 50% of the connections
50	<100 counts/5 min for all connections
59	<5 count.45 min for all connections

**Table 2-M  
LONGITUDINAL BALANCE**

FREQUENCY (Hz)	MINIMUM BALANCE (dB)	AVERAGE BALANCE (dB)
200	58	63
500	<b>58</b>	63
1000	<b>58</b>	63
3000	53	58

Table 2-N  
QUANTIZATION DISTORTION

INPUT LEVEL BELOW OVERLOAD	SIGNAL/DISTORTION RATIO (dB)
3 to 33	33
33 to 43	27
43 to 48	22

**Note:** Input signal is 820 Hz sinewave; output measured with psophometric weighting. (See Table 2-J for a definition of overload.)



### 3. DTI LOSS TABLES

---

3.01 Tables 3-A through 3-D provide the insertion loss specifications of the SL-1 Business Communications System when it is equipped with a QPC472 Digital Trunk Interface (DTI).

3.02 The insertion loss for connections between analog ports of the SL-1 and the DTI or between DTI ports is connection-specific in order to be compatible with end-to-end network connection loss requirements. SL-1' connection loss specifications are in agreement with U.S. and Canadian standards which are formulated to provide satisfactory transmission on connections between switches in a \*private network and between a private network and the public network. (EIA Communications Interim Standard, CIS-4 (U.S.); Department of Communications Standard CS-03 (Canada).) This formulation is based on the use of a fixed loss plan for digital portions of these connections. As a result, certain connections through the SL-1 are asymmetrical: this asymmetry is resolved at the far end of the connection.

3.03 Tie trunk connections to a satellite PBX require different loss treatment than non-satellite tie trunks. The insertion loss for satellite tie trunk connections is given in Tables 3-C and 3-D. Loss values associated with tie trunks in Tables 3-A and 3-B should not be applied to satellite PBX tie trunk connections.

Note: In this NTP, "satellite" denotes a PBX which homes on a main PBX and does not have a directory number for incoming calls: satellite tie trunks are trunks connecting such a PBX to the main PBX. There is no explicit or implied reference to facilities using satellite (i.e., space vehicle) circuits.

3.04 In these tables, the notation "1000 Hz Insertion Loss" refers to a sinusoidal signal having a frequency between 1000 and 1020 Hz; the value of 1004 Hz has been standardized in the telephone industry in order to avoid frequency beating of an exact 1000 Hz signal in the presence of PCM carrier systems.

Table 3-A  
 1000 Hz INSERTION LOSS FOR CONNECTIONS BETWEEN AN ANALOG PORT  
 AND A DIGITAL TRUNK INTERFACE (DTI) PORT

TYPE OF CONNECTION	ANALOG PORT	DIGITAL PORT	NOMINAL INSERTION LOSS (dB)	
			Analog port to DTI	DTI to Analog port
Station to Trunk	Local Station	Tie Trunk	3	9
	Local Station	CO/FX/WATS	3	3
	Local Station	Toll WATS (Note 1)	3	9
	OPS	Tie Trunk	0	6
	OPS	CO/FX/WATS	0	0
	OPS	Toll WATS (Note 1)	0	6
Trunk to Trunk	Tie Trunk	Tie Trunk	- 2	4
	Tie Trunk	CO/FX/WATS	3	3
	Tie Trunk	Toll WATS (Note 1)	- 2	4
	Tie Trunk-ESN	Tie Trunk	-2.5	3.5
	Tie Trunk-ESN	CO/FX/WATS	2.5	2.5
	Tie Trunk-ESN	Toll WATS (Note 1)	-2.5	3.5
	CO/FX/WATS	Tie Trunk	0	6
	CO/FX/WATS	CO/FX/WATS	0	0
	CO/FX/WATS	Toll WATS (Note 1)	0	6
	Toll WATS (Note 1)	Tie Trunk	- 3	3
	Toll WATS (Note 1)	CO/FX/WATS	3	3
	Toll WATS (Note 1)	Toll WATS (Note 1)	0	6

**Note 1:** Toll WATS is a trunk to a Toll (Class 4) office for WATS access.

**Note 2:** Insertion loss limits are nominal loss  $\pm 0.7$  dB.

**Table 3-8**  
**1000 Hz INSERTION LOSS FOR CONNECTIONS BETWEEN TWO PORTS**  
**OF A DIGITAL TRUNK INTERFACE (DTI)**

TYPE OF CONNECTION	DIGITAL PORT (A)	DIGITAL PORT (B)	NOMINAL INSERTION LOSS (dB)	
			DTI port (A) to DTI port (B)	DTI port (B) to DTI port (A)
Trunk to Trunk	Tie Trunk	Tie Trunk	0	0
	Tie Trunk	CO/FX/WATS	6	0
	Tie Trunk	Toll WATS (Note 1)	0	0
	CO/FX/WATS	CO/FX/WATS	3	3
	CO/FX/WATS	Toll WATS (Note 1)	0	6
	Toll WATS (Note 1)	Toll WATS (Note 1)	0	0

**Note 1:** Toll WATS is a trunk to a Toll (Class 4) office for WATS access.

**Note 2:** Insertion loss limits are nominal loss  $\pm 0.2$  dB.

**Table 3-C**  
**1000 Hz INSERTION LOSS FOR CONNECTIONS-BETWEEN AN ANALOG PORT**  
**AND A DIGITAL TRUNK INTERFACE (DTI) PORT**  
**FOR CONNECTIONS TO A SATELLITE PBX**

TYPE OF CONNECTION	ANALOG PORT	DIGITAL PORT (Note 1)	NOMINAL INSERTION LOSS (dB)	
			Analog port to DTI	DTI to Analog port
Station to Satellite Tie Trunk	Local Station	Comb. STT	3	9
	Local Station	Digital STT	3	3
	OPS	Comb. STT	0	6
	OPS	Digital STT	2	2
Non-satellite Trunk to Satellite Tie Trunk	Tie Trunk	Comb. STT	- 2	4
	Tie Trunk	Digital STT (Note 3)	3	3
	Tie Trunk-ESN	Comb. STT	-2.5	3.5
	Tie Trunk-ESN	Digital STT (Note 4)	2.5	2.5
	CO/FX/WATS	Comb. STT	- 3	3
	CO/FX/WATS	Digital STT	0	0
	Toll WATS (Note 2)	Comb. STT	- 3	3
	Toll WATS (Note 2)	Digital STT	3	3
Satellite Tie Trunk to DTI Trunk	STT	Comb. STT	1	7
	STT	Digital STT	1	1
	STT	Tie Trunk (non-satellite)	1	7
	STT	CO/FX/WATS	1	1
	STT	Toll WATS (Note 2)	1	7
	STT-ESN	Comb. STT	0.5	6.5
	STT-ESN	Digital STT	0.5	0.5
	STT-ESN	Tie Trunk (hoc-satellite)	0.5	6.5

Table 3-C Continued  
 1000 Hz INSERTION LOSS FOR CONNECTIONS BETWEEN AN ANALOG PORT  
 AND A DIGITAL TRUNK INTERFACE (DTI) PORT  
 FOR CONNECTIONS TO A SATELLITE PBX

TYPE OF CONNECTION	ANALOG PORT	DIGITAL PORT (Note 1)	NOMINAL INSERTION LOSS (dB)	
			Analog port to DTI	DTI to Analog port
	STT-ESN	CO/FX/WATS	0.5	0.5
	STT-ESN	Toll WATS (Note 2)	0.5	6.5

**Note 1:** DTI port to Combination or Digital Satellite Tie Trunks (STT) unless otherwise noted.

**Note 2:** Toll WATS is a trunk to a Toll (Class 4) office for WATS access.

**Note 3:** Optionally. 1 dB loss each direction may be specified, provided the satellite PBX does not serve OPS lines.

**Note 4:** Optionally. 0.5 dB loss each direction may be specified, provided the satellite PBX does not serve OPS lines.

**Note 5:** Insertion loss limits are nominal loss  $\pm 0.7$  dB.



↖ Table 3-D  
**1000 Hz INSERTION LOSS FOR CONNECTIONS BETWEEN TWO PORTS  
 OF A DIGITAL TRUNK INTERFACE (DTI)  
 FOR CONNECTIONS TO A SATELLITE PBX**

TYPE OF CONNECTION	DIGITAL PORT (A) (Note 1)	DIGITAL PORT (B) (Note 1)	NOMINAL INSERTION LOSS (dB)	
			DTI port (A) to DTI port (B)	DTI port (B) to DTI port (A)
Satellite Trunk to Trunk	Comb. STT	Comb. STT	0	0
	Comb. STT	Digital STT	6	0
	Comb. STT	Tie Trunk (non-satellite)	0	0
	Comb. STT	CO/FX/WATS	6	0
	Comb. STT	Toll WATS (Note 2)	0	0
	Digital STT	Digital STT	0	0
	Digital STT	Tie Trunk (non-satellite)	0	6
	Digital STT	CO/FX/WATS	0	0
	Digital STT	Toll WATS (Note 2)	0	6

**Note 1:** DTI port to Combination or Digital Satellite Tie Trunks (STT) unless otherwise noted.

**Note 2:** Toll WATS is a trunk to a Toll (Class 4) office for WATS access.

**Note 3:** Insertion loss limits are nominal loss  $\pm 0.2$  dB.

4



553-3001-161

SL-1

# System options 21, 51, 61, 71

Analog line card description  
Standard

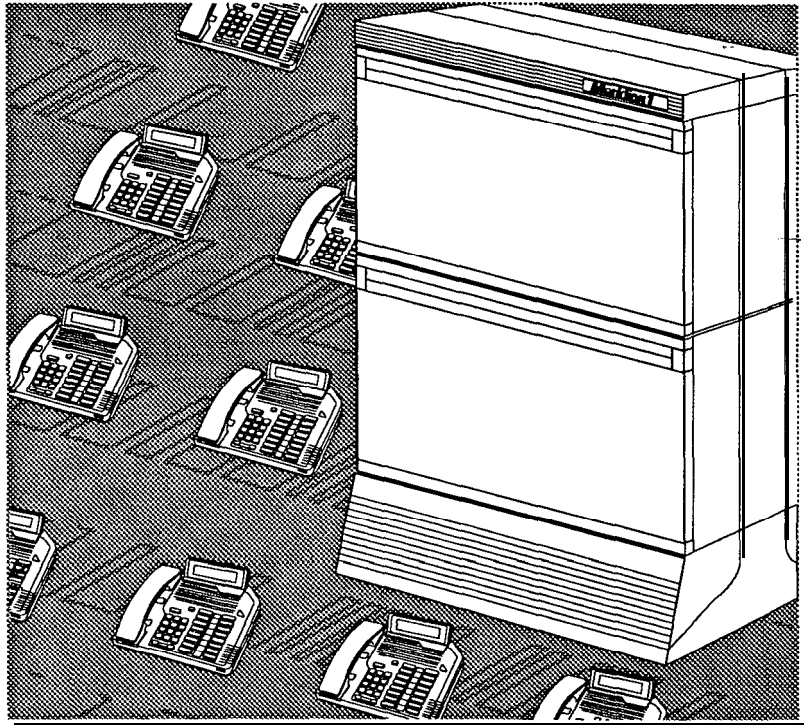

**nt** north  
telecom

**Meridian 1**  
Communication Systems



---

SL-1

# **System options 21, 51, 61, 71**

Analog line card description

---

Publication number: 553-3001-I 61

Document release: 1 .0

Document status: Standard

Date: January 29, 1990

---

© 1990 Northern Telecom

All rights reserved.

---

Analog line card description 553-3001-I 61

---

# Revision history

---

**January 29, 1990**

Standard, release 1.0

---

## About this document

---

This practice outlines the characteristics, application, and operation of the NT8D03AB Analog Line Card. The information is intended to be used as a guide when connecting customer-provided apparatus to the line circuit. New naming conventions are applied to this release. The following documents should be used as references to this document:

### References

*See the SL-I planning & engineering guide* for

- *Master index* (553-3001-000)
- *System overview* (553-3001-100)
- *System engineering* (553-3001-151)
- *Sparesplanning* (553-3001-153)
- *Equipment identification and ordering* (553-3001-M)

See the list of line and trunk circuit descriptions in the *Master index* (553-3001-000) for specific references to lines and trunks.

*See the SL-1 installation and maintenance guide* for

- *Circuit pack installation and testing* (553-3001-211)
- *Fault clearing* (553-3001-510)
- *Hardware replacement* (553-3001-520)

See the *SL-1 XII software guide* for an overview of software architecture, procedures for software installation and management, and a detailed description of all XI 1 features and services. This information is contained in two documents:

- ***XII software management*** (553-3001-300)
- ***XII features and services*** (553-3001-305)

**See the *SL-I XII input/output guide* (553-3001-400)** for a description of all administration programs, maintenance programs, and system messages.

See the following Northern Telecom Publications for references to specific telephone sets:

- ***Meridian M2000 digital telephones: description, installation, operation and maintenance*** (553-2201-110)
- ***Meridian M2317 digital telephone with alphanumeric display: description, installation, operation, and maintenance*** (553-2201-113)
- ***Meridian M3000 touchphone: description, installation, operation and maintenance*** (553-2201-115)
- ***Meridian modular telephones: description and specifications*** (553-2201-116)

---

# Contents

---

<b>General information</b>	<b>1</b>
<b>Application</b>	<b>2</b>
<b>Characteristics</b>	<b>3</b>
Functional	3
<b>Technical summary</b>	<b>4</b>
Analog line interface	<b>4</b>
Input impedance	4
Insertion loss	4
Frequency response	4
Message channel noise	5
Power requirements	6
Foreign and surge voltage protections	6
Overload level	6





---

## General information

---

This publication outlines the characteristics, application and operation of the Analog Line Card. The information is intended to be used as a guide when connecting customer-provided apparatus to the line circuit. The following Analog Line Card is available:

— **NT8D03AB** — Analog Line Card ( **$\mu$ -Law**)

The Analog Line Card provides talk battery and signaling for regular **2-wire** common battery **500-type** (rotary dial), **2500-type** (DIGITONE dial) telephones and key telephone equipment.

*Note:* **DIGITONE** is a trademark of Northern Telecom.

The **NT8D03AB** Analog Line Card mounts in an **NT8D37AA** Intelligent Peripheral Equipment Module (**IPE**). The circuit connects with the switching system and with the external apparatus via an **80-pin** connector at the rear of the pack. The pack is 3 18 mm (12.5 in) in height and 254 mm (10 in) in depth.

The circuits are connected to the shelf backplane and fed to the I/O panel via I/O cables. From the I/O panel, the circuits are connected to the **cross-connect** terminal via **25-pair** cables. Connection to the station apparatus is made at the cross-connecting terminal.

---

# Application

---

The line circuit interfaces and is compatible with the equipment listed in Table 1.

Table 1  
Line circuit application and **compatibility**

Equipment	Specifications
<b><i>NE-500 type rotary dial sets (or equivalent)</i></b>	
Dial Speed	8.0 to 22.5 <b>pps</b>
Percent Break	58 to 70%
Interdigital Time	240 ms
<b><i>NE-2500 type Digitone sets (or equivalent)</i></b>	
Frequency Accuracy	<b>± 1.5 %</b>
Pulse Duration	40 ms
Interdigital Time	40 ms
<b>Speed</b>	12.5 digits/s

---

# Characteristics

---

## Functional

The Analog Line Card contains an 8050 microprocessor that provides the following functions:

- card self-identification
- self-test
- control card operation
- status report to the controller
- diagnostics for maintenance purposes

The Analog Line Card also provides the following:

- **600Ω** balanced terminating impedance
- analog-to-digital and digital-to-analog conversion of transmission and reception signals for 16 audio phone lines
- transmission and reception of SSD signalling messages over a **DS30X** signalling channel in A10 format
- detection of on-hook/off-hook status
- connection of 20 Hz ringing signal and automatic disconnection when the station goes **offhook**
- synchronization for connecting and disconnecting the ringing signal to zero crossing of ringing voltage
- **loopback** of SSD messages and PCM signals for diagnostic purposes
- indication of board status with faceplate-mounted LED
- correct initialization of all features at power-up
- direct reporting of digit dialed (500 sets) by collecting dial pulses

# Technical summary

---

## Analog line interface

### Input impedance

The impedance at tip and ring is 600 Ohm with a return loss of  
20 dB for 200-500 Hz  
26 dB for 500-3400 Hz

### Insertion loss

On a station line-to-line **connection**, the total insertion loss at 1 KHz is 6dB  $\pm$  1dB. This is arranged as 3.5dB loss for analog to PCM and 2.5dB loss for PCM to analog.

### Frequency response

The loss values in the table below are measured relative to the loss at 1 KHz:

**Table 2**  
Frequency response

Frequency	Minimum	Maximum
60 Hz	20.0 dB	
200 Hz	0.0 dB	5.0 dB
300 Hz	-0.5 dB	1.0dB
3000 Hz	-0.5 dB	1.0dB
3200 Hz	-0.5 dB	1.5 dB
3400 Hz	0.0 dB	3.0 dB

## Message channel noise

The message channel noise C-weighted (**dBmC**) on 95% of the connections (line to line) with both ends terminated in **600** ohms does not exceed 20 **dBmC**.

A technical summary of the Analog line **circuit** pack is given in Table 3.

Table 3

### Technical summary of Analog Line Card

<b>Impedance:</b>	<b>600 <math>\Omega</math></b>
<b>Loop limit (excluding set)</b>	1000 $\Omega$ at nominal <b>-48 V</b> (excluding set)
<b>Leakage resistance</b>	30,000 $\Omega$
<b>Ring trip</b>	During silent or ringing intervals
<b>Ringling voltage</b>	86Vac
<b>Signaling</b>	Loop start
<b>Supervision</b>	<b>Normal</b> battery conditions are continuously applied ( <b>-48 V</b> on ring; ground on tip)
<b>Power input from shelf backplane</b>	<b>-48, +15, -15, +8.5 V</b> and ringing voltage; also -150 V on Message Waiting Line card.
<b>Insertion loss</b>	6dB $\pm$ 1dB at 1020 Hz 3.5dB loss for analog to F'CM, 2.5dB loss for PCM to analog
<b>Effective gain</b>	1.5dB at 1020 Hz

## Power requirements

### NT8D03AB

The NT8D03AB Analog Line Card has the following power requirements:

Voltage (+/-)	Tolerance	Idle Current	Active Current	Max
+ 15.0 V dc	0.50 V dc	48 ma	0 ma	48 ma
+ 8.5 V dc	1.00 V dc	150 ma	8 ma	280 ma
▪ 48.0 V dc	2.40 V dc	48 ma	40 ma	688 ma
▪ 48.0 V dc	2.40 V dc	0 ma	(1) 10 ma	320 ma
86.0 V ac	5.00 V ac	0 ma	(2) 10 ma	160 ma
-150.0 V dc	5.00 V dc	0 ma	2 ma	32 ma

**Note:** (1) Each active ringing relay requires 10 ma of battery voltage.

(2) Reflects the current for ringing a single station set. There may be as many as five ringers on each line.

## Foreign and surge voltage protections

When telephone lines connected to the line circuit are exposed to foreign voltages by direct contact or induction (for example, power line crosses or lightning), protection devices must be installed on the customer's premises. These devices must be capable of providing a path to ground from tip and ring for foreign voltages that exceed 600 V peak.

## Overload level

Signal levels exceeding + 7 dBm applied to the tip and ring cause distortion in speech transmission.





SL-1 System

## **Options 21, 51, 61, 71**

Analog line card description

Copyright © 1990 Northern Telecom  
**All** rights reserved.  
Information subject to change without notice.  
Release 1.0  
Standard  
January **29, 1990**  
Printed in U.S.A.



553-3001-162

SL-1

# System options 21, 51, 61, 71

Digital line card description  
Standard

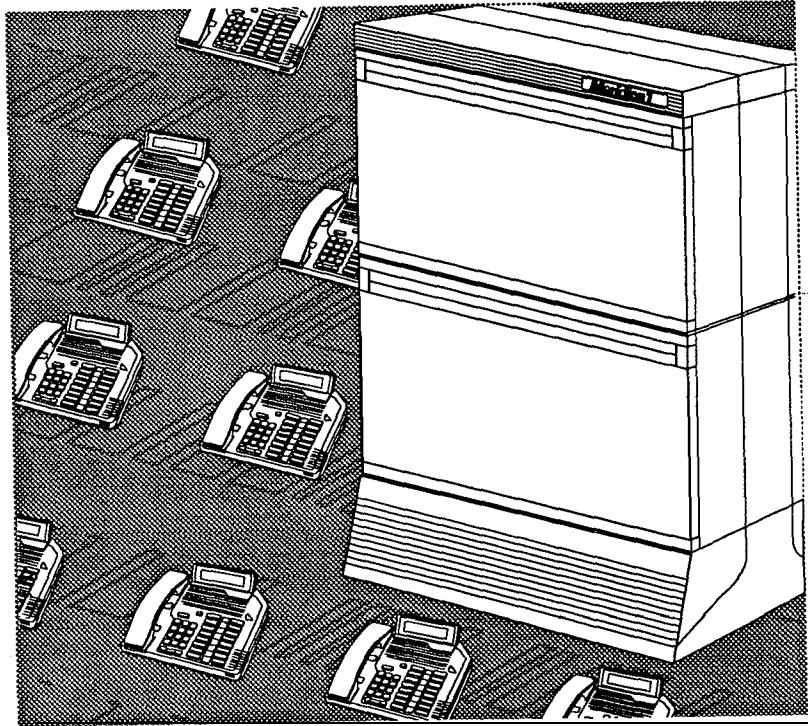

**nt** northern  
telecom

**Meridian1**  
Communication Systems



11



---

SL-1

# System options 21, 51, 61, 71

Digital line card description

---

Publication number: 5533001-I 62

Document status: Standard

Document release: 1 .0

Date: January **29, 1990**

---

© 1990 Northern **Telecom**

All rights reserved.

---

Digital line card description 553-3001-I 62

ii

---

## Revision history

---

**January 29, 1990**

First issue of this document.

---

## About this document

---

This practice outlines the characteristics, application, and operation of the **NT8D02AA** Digital Line Card (**Dgtl LC**). The information is intended to be used as a guide when connecting customer-provided apparatus to the line circuit. New naming conventions are applied to this release. The following documents should be used as reference material:

### References

See the **SL-1 Planning & Engineering Guide** for

- **Muster Index** (553-3001-000)
- **System Overview** (553-3001-100)
- **System Engineering** (553-3001-151)
- **Spares Planning** (553-3001-153)
- **Equipment Identification and Ordering** (553-3001-154)

See the list of Line and Trunk Circuit Descriptions in the **Muster Index** (553-3001-000) for specific references to lines and trunks.

See the **SL-1 Installation and Maintenance Guide** for

- **Circuit Pack Installation and Testing** (553-3001-211)
- **Fault Clearing** (553-3001-510)
- **Hardware Replacement** (553-3001-520)

See the **SL-1 XI 1 Software** Guide for an overview of software architecture, procedures for software installation and management, and a detailed description of all XI 1 features and services. This information is contained in two documents:

— *XII Software Management* (553-3001-300)

— *XII Features and Services* (553-3001-305)

See the *SL-I XII Input/Output Guide* (553-300140) for a description of all administration programs, maintenance programs, and system messages.

See the following Northern Telecom Publications for references to specific telephone sets:

— *Meridian M2000 digital telephones: description, installation, operation and maintenance* (553-2201-110)

— *Meridian M2317 digital telephone with alphanumeric display: description, installation, operation, and maintenance* (553-2201-113)

— *Meridian M3000 touchphone: description, installation, operation and maintenance* (553-2201-115)

— *Meridian modular telephones: description and specifications* (553-2201-1 16)

---

# Contents

---

<b>General information</b>	<b>1</b>
Requirements	1
<hr/>	
<b>Description</b>	<b>3</b>
Meridian SL-1 data block	3
Physical	3
Functional	4
Configuration	4
Power supply to digital telephones	4
<hr/>	
<b>Characteristics</b>	<b>5</b>

---





---

## General information

---

The **NT8D02AA** Digital Line Card (**Dgtl LC**) is based on the design of the **QPC578** Integrated Services Digital Line Card. See 553-2201-193 for a complete description of the QPC578. The Dgtl LC is a voice and data communication link **between** the Meridian SL-1 switch and modular digital telephones. When a digital telephone is equipped with the data option, an asynchronous ASCII terminal or PC can be connected to SL-1 System through the digital telephone.

The **Dgtl LC** supports voice only or simultaneous voice and data service over a single twisted pair of standard telephone wiring.

This publication describes the Dgtl LC. New naming conventions are applied to this document.

For more information on modular digital telephones, see 553-2201-110 and 553-2201-111 for the **M2000** series telephones, 553-2201-115 for the **M3000** telephone, and **553-2201-113** for the M23 17 telephone.

### Requirements

To use the Dgtl LC, the following SL-1 requirements must be met:

- Intelligent Peripheral Equipment (**IPE**) Modules must be used
- Generic XI 1, Release 15 software must be running
- Superloops must be defined in the software



---

## Description

---

The **NT8D02AA** Digital Line Card (**Dgtl LC**) is equipped with 16 identical line circuits housed within an **NT8D37AA** Intelligent Peripheral Equipment Module (**IPE**). Each line circuit provides a multiplexed voice, data, and signaling path to and from digital apparatus over a **2-wire** full duplex 5 12 **KHz** Time Compression Multiplexed (**TCM**) digital link.

### Meridian SL-1 data block

Each digital telephone and each associated data terminal is assigned a separate Terminal Number (TN) in the SL-1 System data base.

### Physical

Dgtl LC circuitry is contained on a 320 mm (12.5 in.) by 254 mm (10 in.) double-sided printed circuit board. The pack connects to the backplane via a **120-pin** edge connector.

The faceplate of the Dgtl LC (**7/8** in. wide) snaps in place on the front of the pack and is equipped with a red LED which lights only when the pack is disabled. Upon power-up, the **Dgtl LC** resets and **the** red LED will turn off after the Dgtl LC is enabled. The card provides self-identification and fault detection.

For information on the Mean Time Between Failure rate for **the** Dgtl LC, see *Spares Planning* (553-3001-153).

### Functional

The Dgtl LC contains an 8050 microprocessor that provides **the** following functions:

- card self-identification
- self-test
- control card operation
- status report to the controller
- diagnostics for maintenance purposes

### Configuration

Up to 16 **Dgtl** LC circuit packs can be mounted in one PE shelf if the remaining slots are not used. In addition, up to 16 Dgtl LC packs can be supported by a single **NT8D06AA** Peripheral Equipment Power Supply (**PE Pwr Sup**). The PE Pwr Sup is available for both ac and dc power. ..

### Power supply to digital telephones

The Dgtl LC needs  **$\pm 15V$**  dc over each loop at a maximum current of 80 **mA**. The line feed interface can supply power to one loop of varying length up to 1067 m (3500 ft) using 24 AWG gauge wire with a maximum allowable ac signal loss of 15.5 **dB** at 256 KHz, and a maximum dc loop resistance of 210 ohms.; 26 AWG gauge wire is limited to 745 m (2450 ft). --

For a detailed description of the exact power requirements of each set type, refer **to Meridian modular telephones** (553-2201-1 16)

---

# Characteristics

---

Table 1  
Digital Line Card circuit characteristics

Characteristics	Description
Circuits per pack	16 voice, 16 data
Options	Nil
Impedance	1008
Loop limits	100 ft (30 m) to 3000 ft (900 m) with 24 AWG PVC cable ( $\pm 15$ VDC at 80 mA)] 0 to 3500 ft (1067 m) with 24 AWG PVC cable ( $\pm 15$ VDC at 80 mA)]

## 6 Characteristics

---

Table 1 continued  
Digital Line Card circuit characteristics

Characteristics	Description
Line rate	512 kbps $\pm$ 100 ppm
Power supply	+ 5vdc $\pm$ 15 V dc +10 V dc
Transmitter output voltage	
-successive "1" bits	$+1.5 \pm 0.15$ V and $-1.5 \pm 0.15$ V
—"0" bits	$0 \pm 50$ mV

**Note:** The Dgtl LC requires +15V, -15V, and +5V from the backplane.





SL-1

## System options **21, 51, 61, 71**

Digital line card description

© 1990 Northern Telecom  
All rights reserved.  
Information subject to change without notice.  
Release 1.0  
Standard  
January 29, 1990  
Printed in U.S.A.



553-3001-163

SL-1

## System options 21, 51, 61, 71

Analog message waiting line card description  
Standard

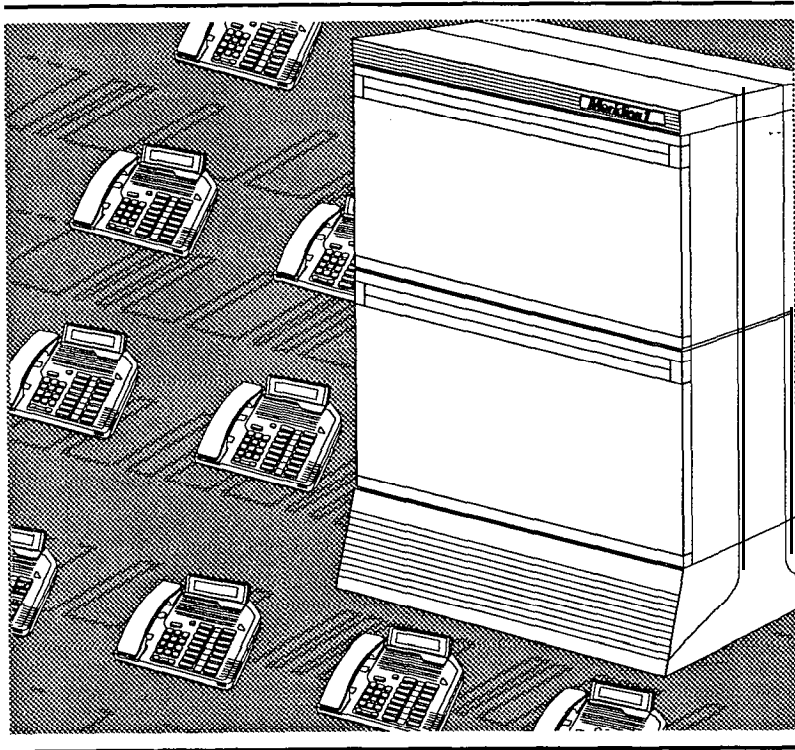

**nt** northern  
telcom

**Meridian 1**  
Communication Systems





---

SL- 1

# **System options 21, 51, 61, 71**

Analog message waiting line card description

---

Publication number: 553-3001-I 63

Document release: 1 .0

Document status: Standard

Date: January **29, 1990**

---



© 1990 Northern **Telecom**

All rights reserved.

ii

---

## Revision history

---

January 29, 1990

Standard, release 1.0

---

## About this document

---

This practice outlines the characteristics, application, and operation of the **NT8D09AB** Analog Message Waiting Line Card. The information is intended to be used as a guide when connecting customer-provided apparatus to the line circuit. New naming conventions are applied to this release. The following documents should be used as a reference:

### References

*See the **SL-1 planning & engineering guide** for*

- **Master index** (553-3001-000)*
- **System overview** (553-3001-100)*
- **System engineering** (553-3001-151)*
- **Sparesplanning** (553-3001-153)*
- **Equipment identification and ordering** (553-3001-154)*

See the list of line and trunk circuit descriptions in the **Master index** (553-3001-000) for specific references to lines and trunks.

*See the **SL-1 installation and maintenance guide** for*

- **Circuit pack installation and testing** (553-3001-211)*
- **Fault clearing** (553-3001-510)*
- **Hardware replacement** (553-3001-520)*

See the **SL-1 X11 software guide** for an overview of software architecture, procedures for software installation and management, and a detailed description of all X 11 features and services. This information is contained in two documents:

- *X11 software management* (553-3001-300)
- *X11 features and services* (553-3001-305)

**See the *SL-1 XII input/output guide* (553-3001-400)** for a description of all administration programs, maintenance programs, and system messages.

See the following Northern Telecom Publications for references to specific telephone sets:

- ***Meridian M2000 digital telephones: description, installation, operation and maintenance*** (553-2201-110)
- ***Meridian M2317 digital telephone with alphanumeric display: description, installation, operation, and maintenance*** (553-2201-113)
- ***Meridian M3000 touchphone: description, installation, operation and maintenance*** (553-2201-1 15)
- ***Meridian modular telephones: description and specifications*** (553-2201-1 16)

---

# Contents

---

<b>General information</b>	<b>1</b>
<b>Application</b>	<b>3</b>
<b>Characteristics</b>	<b>5</b>
Functional	5
<b>Technical summary</b>	<b>7</b>
Analog line interface	<b>7</b>
Input impedance	7
Insertion loss	-- 7
Frequency response	7
Message channel noise	8
Power requirements	9
Foreign and surge voltage protections	9
Overload level	9





---

## General information

---

This publication outlines the characteristics, application, and operation of the Analog Message Waiting Line Card. The information is intended to be used as a guide when connecting customer-provided apparatus to the line circuit. The following Analog Message Waiting Line Card is available:

— **NT8D09AB** — Analog Message Waiting Line Card @-Law)

The Analog Message Waiting Line Card provides talk battery and signaling for regular 2-wire common battery **500-type** (rotary dial), **2500-type** (DIGITONE dial) telephones and key telephone equipment.

*Note:* **DIGITONE** is a trademark of Northern Telecom.

The **NT8D09AB** Analog Message Waiting Line Card mounts in any of the 16 slots in an **NT8D37AA** Intelligent Peripheral Equipment Module (IPE). The 16 circuits connect with the switching system and with the external apparatus via a **160-pin** connector at the rear of the pack. The pack is 320 mm (12.5 in) in height and 254 mm (10 in) in depth.

The circuits are connected to the shelf backplane and fed to the I/O panel via I/O cables. From the I/O panel, the circuits are connected to the **cross-connect** terminal via **25-pair** cables. Connection to the station apparatus is made at the **cross-connecting** terminal

## 2 General information

---



---

# Application

---

The line card interfaces and is compatible with the equipment **listed** in Table 1.

**Table 1**  
Line card application and compatibility

Equipment	Specifications
<b><i>NE-500 type rotary dial sets (or equivalent)</i></b>	
Dial Speed	<b>8.0</b> to 12.5 pps
Percent Break	<b>58</b> to 70%
Interdigital Time	<b>240 ms</b>
<b><i>NE-2500 type Digitone sets (or equivalent)</i></b>	
Frequency Accuracy	$\pm 1.5\%$
Pulse Duration	<b>40 ms</b>
Interdigital Time	<b>40 ms</b>
<b>Speed</b>	12.5 digits/s

## 4 Application

---



---

# Characteristics

---

## Functional

The Analog Message Waiting Line Card contains a microprocessor that provides the following functions:

- card self-identification
- self-test
- control card operation
- status report to the controller
- diagnostics for maintenance purposes

The Analog Message Waiting Line Card also provides the following: --

- **600Ω** balanced terminating impedance
- analog-to-digital and digital-to-analog conversion of transmission and reception signals for 16 audio phone lines
- transmission and reception of SSD signalling messages over a **DS30X** signalling channel in A10 format
- detection of on-hook/off-hook status and switchhook flash
- connection of 20 Hz ringing signal and automatic disconnection when the station goes **offhook**
- synchronization for connecting and disconnecting the ringing signal to zero crossing of ringing voltage
- **loopback** of SSD messages and PCM signals for diagnostic purposes
- indication of board status with faceplate-mounted LED

## 6 Characteristics

---

- correct initialization of all features at **power-up**
- connection of -150 Vdc at 1 Hz to activate message waiting lamps
- direct reporting of digit dialed (500 sets) by collecting dial pulses
- detection of lamp status
- disable/enable-selected circuits for maintenance



---

# Technical summary

---

## Analog line interface

### Input impedance

The impedance at tip and ring is 600 Ohm with a return loss of  
20 dB for 200-500 Hz  
26 dB for 500-3400 Hz

### Insertion loss

On a station line-to-line connection, the total insertion loss at 1 KHz is 6dB  $\pm$  1dB. This is arranged as 3.5dB loss for analog to PCM and 2.5dB loss for PCM to analog.

### Frequency response

The loss values in the table below are measured relative to the loss at 1 KHz:

Table 2  
Frequency response

Frequency	Minimum	Maximum
60 Hz	20.0 dB	
200 Hz	0.0 dB	5.0 dB
300 Hz	-0.5 dB	1.0 dB
3000 Hz	-0.5 dB	1.0 dB
3200 Hz	-0.5 dB	1.5 dB
3400 Hz	0.0 dB	3.0 dB



**Message channel noise-**

The message channel noise C-weighted (**dBmC**) on 95% of the connections (line to line) with both ends terminated in 600 ohms does not exceed 20 **dBmC**.

A technical summary of the line card is given in **Table 3**.

**Table 3**  
**Technical summary of Analog Message Waiting**  
**Line Card**

<b>Impedance:</b>	<b>600 Ω</b>
<b>Loop limit (excluding set)</b>	<b>1000 Ω</b> at nominal -48 V
<b>Leakage resistance</b>	<b>30,000 Ω</b>
<b>Ring trip</b>	During silent or ringing intervals
<b>Ringling voltage</b>	86Vac
<b>Signaling</b>	Loop start
<b>Supervision</b>	Normal battery conditions are continuously applied ( <b>-48 V</b> on ring; ground on tip)
<b>Power input from shelf backplane</b>	-48, <b>+15</b> , -15, <b>+8.5 V</b> and ringing voltage; also - 150 V on Message Waiting Line card.
<b>Insertion loss</b>	6dB <b>±1dB</b> at 1020 Hz <b>3.5dB</b> loss for analog to PCM, <b>2.5dB</b> loss for PCM to analog
<b>Effective gain</b>	<b>1.5dB</b> at 1020 Hz

## Power requirements

### NT8D09AB

The **NT8D09AB** Analog Message Waiting Line Card has the following power requirements:

**Table 4**  
Power requirements

Voltage (+/-)	Tolerance	Idle current	Active current	Max
+ 12.0 V dc	0.36 V dc	48 ma	0 ma	48 ma
+ 8.0 V dc	0.40 V dc	150 ma	8 ma	280 ma
- 48.0 V dc	2.00 V dc	48 ma	40 ma	688 ma
• 48.0 V dc	5.00 V dc	0 ma	(1) 10 ma	320 ma
88.0 V ac	5.00 V ac	0 ma	(2) 10 ma	160 ma
-150.0 V dc	3.00 V dc	0 ma	2 ma	32 ma

Note: (1) Each active ringing relay requires 10 ma of battery voltage.

(2) Reflects the current for ringing a single station set. There may be as many as five ringers on each line. --

## Foreign and surge voltage protections

When telephone lines connected to the line circuit are exposed to foreign voltages by direct contact or induction (for example, power line crosses or lightning), protection devices must be installed on the customer's premises. These devices must be capable of providing a path to ground from tip and ring for foreign voltages that exceed 600 V peak.

## Overload level

Signal levels exceeding + 7 dBm applied to the tip and ring cause distortion in speech transmission.

SL-1

## **System options 21, 51, 61,71**

Analog message waiting line card  
description

Copyright © 1990 Northern Telecom  
All rights reserved.  
Information subject to change without notice.  
Release 1 .0  
Standard  
January **29, 1990**  
Printed in U.S.A.



---

**INTEGRATED SERVICES NETWORK** ←**MERIDIAN SL-1.** ←**SL-1 LINE AND CONSOLE LINE PACKS  
DESCRIPTION AND OPERATION**

---

<b>CONTENTS</b>	<b>PAGE</b>
1. <b>GENERAL</b>	1-1
2. <b>DESCRIPTION</b>	2-1
<b>Functions</b>	2-1
<b>Physical Description</b>	2-1
<b>Interconnection with Shelf</b>	2-2
<b>Power Supply to Terminals</b>	2-2
3. <b>CIRCUIT CHARACTERISTICS</b>	3-1
4. <b>OPERATION WITH SL-1 SET</b>	4-1
<b>Idle Circuit States</b>	4-1
<b>Call Originated from an SL-1 Set</b>	4-1
<b>Call to SL-1 Set</b>	4-2
<b>Class-of -Service and Features</b>	4-6
5. <b>DESIGN CONSIDERATIONS</b>	5-1
<b>Foreign and Surge Voltage Protection</b>	5-1
<b>Overload Level</b>	5-1

\* Meridian and SL-1 are trademarks of Northern  
Telecom Limited



## 1. GENERAL

---

1.01 This practice outlines the functions, interconnections, characteristics and operation of the SL-1 Business Communications System, SL-1 Line and Console Line circuit packs. The information is intended to be used as a guide when designing or engineering the connection of apparatus to the line circuit.

1.02 The information in this practice applies to the following packs:

- QPC451 SL-1 Line ( $\mu$ -Law)
- QPC520 SL-1 Line (A-Law)
- QPC518 Console Line ( $\mu$ -Law) (superseded by the QPC451) ←
- QPC519 Console Line (A-Law).

1.03 The four packs use identical circuit boards but are configured for their respective operation. The SL-1 line packs can each interface to up to eight SL-1 sets. The console line packs can interface to two attendant consoles. The QPC451 SL-1 line pack can be used for four attendant-consoles without console power or two attendant consoles with console power. ↴



1. The first part of the document discusses the importance of maintaining accurate records of all transactions and activities. It emphasizes the need for transparency and accountability in financial reporting.

2. The second part of the document outlines the various methods and techniques used to collect and analyze data. It includes a detailed description of the experimental procedures and the statistical tools employed.

3. The third part of the document presents the results of the study, showing the trends and patterns observed in the data. It includes several tables and graphs to illustrate the findings.

4. The fourth part of the document discusses the implications of the results and provides recommendations for future research. It highlights the areas that need further exploration and the potential applications of the findings.

5. The final part of the document is a conclusion that summarizes the key points of the study and reiterates the importance of the research.

## 2. DESCRIPTION

---

### FUNCTIONS

2.01 The SL-1 and console line circuit packs each contain eight line circuits (see Fig. 2-1). The SL-1 line pack can use all eight circuits, each circuit interfacing to an SL-1 set. The console line pack uses pairs of line circuits to interface to attendant consoles: one pair may be used from the upper four circuits and one pair from the lower four to interface to two consoles.

**Note:** Line circuits on the SL-1 line pack are automatically powered up during signaling and transmission. The connected circuit pairs on the console line pack are continuously powered on.

2.02 For SL-1 set connections, one pair of wires is used for transmission and a second pair for signaling (see Fig. 2-2). For attendant console connections, two pairs of wires are used for transmission connections and two pairs for signaling connections. These connections:

- (a) terminate the loop tip and ring conductors with a balanced 600-ohm termination;
- (b) provide  $\pm 15$  V power, phantomed over the transmission and signaling pairs, to the set or console terminals;
- (c) provide a measure of isolation of foreign potentials on the loop from portions of the transmission and signaling circuitry;
- (d) convert from the 2-wire transmission path of the loop to a 4-wire transmission path;
- (e) provide analog-to-digital and digital-to-analog conversion of transmission signals.

2.03 The circuit pack includes two common multiplexing circuits to:

- (a) interface the individual line circuits with the peripheral bus signaling channel;
- (b) retime digital signals received from the peripheral bus;
- (c) decode address information received from the peripheral bus and enable individual line circuits during selected time slots.

2.04 The information and signaling relevant to the SL-1 set or console passes through the line circuit pack and is multiplexed with information from other circuit packs. A multiplex loop connects the input and output of up to two Peripheral Equipment (PE) shelves to the Common Equipment (CE) where switching takes place (see Fig. 2-2 and 2-3).

### PHYSICAL DESCRIPTION

2.05 The line circuits and common circuitry of the pack are mounted on a 12.5 in (320-mm) by 10 in (254-mm) printed circuit board. The front of the pack is equipped with two pack extractors and a Light Emitting Diode (LED). The rear of the pack is equipped with a connector capable of accepting 80 pins. Ten of these circuit packs may be mounted in one PE shelf but not to exceed 50% of the packs in a cabinet.



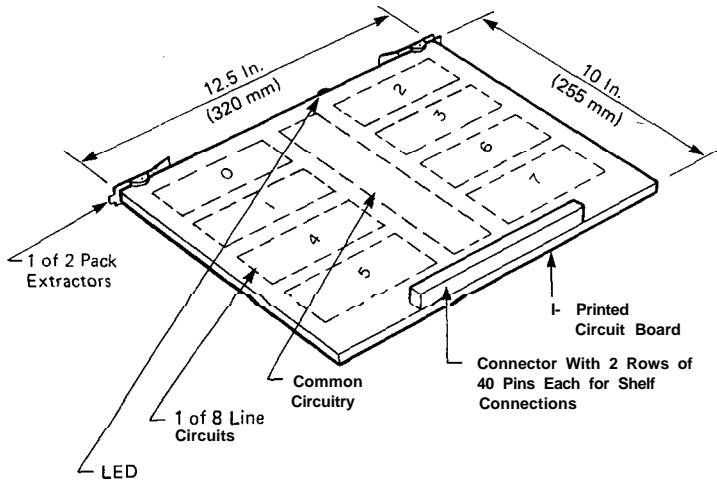

Fig. 2-1  
Identification of the Circuits on the Board

**INTERCONNECTION WITH SHELF**

2.06 The IO-pin connector on the rear of the circuit pack connects to an 80-line bus system at the rear of the PE shelf. The bus lines feed into eight multi-pin connectors. Seven of these connectors link the line circuits to the corresponding terminal equipment and one feeds power to the PE shelf from the power converter shelf.

2.07 Thirty-two of the 80 pins per circuit pack are connected to terminal equipment, 2 pins provide ground, 13 pins interface with the CE via the peripheral buffer and 15 pins provide voltages to the circuit pack.

2.08 For detailed information on terminal set line connections to the four PE shelf connectors, refer to **553-2YY1-210**.

**POWER SUPPLY TO TERMINALS**

2.09 The SL-1 set battery supply is -30 V dc phantom over the audio and signaling leads to each terminal set.

→  
→

2.10 As a general installation guideline, sufficient power is available for the SL-1 set at a normal operating range of 189 ohms (see Loop Limits in Table 3-A).

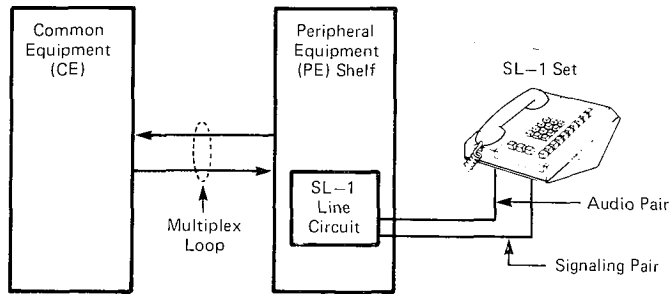

**Fig. 2-2**  
Line Circuit Connection to SL-1 Set

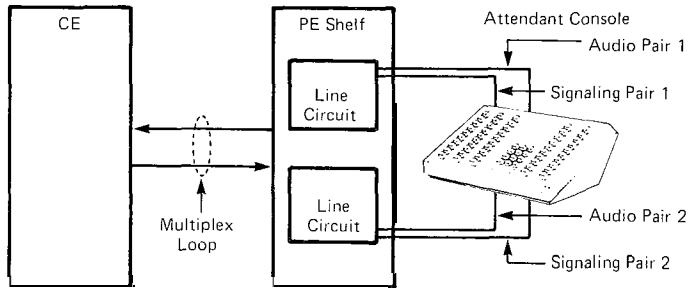

**Fig. 2-3**  
Line Circuit Connection to Attendant Console



1



3. CIRCUIT CHARACTERISTICS

3.01 The circuit characteristics of the line pack are listed in Table 3-A.

**Table 3-A**  
**CIRCUIT CHARACTERISTICS OF THE LINE PACK**

CHARACTERISTICS	AS RELATED TO THE CIRCUIT PACK	
CIRCUITS PER PACK	Eight individual circuits	
OPTIONS	Nil	
IMPEDANCE		
Voice Pair	600 ohms	
Signaling Pair	600 ohms	
NOMINAL INSERTION LOSS	5 dB line-to-line	
LOOP LIMITS	<b>WIRE GAUGE</b>	<b>DISTANCE</b>
	22	6000 feet (1830 m)
	24	3700 feet (1150 m)
	26	2300 feet (675 m)
		--
	<b>Note:</b> Under certain conditions the loop limits may be extended to 8000 feet (2450 m). See 553-2YY1-210.	
SIGNALING PAIR		
Mode	Diphase	
Rate	2.37K bit/s	
Level	0.75 ±0.05 V peak-to-peak across the line.	
AUDIO PAIR		
Mode	Analog (audio)	

Table 3-A Continued  
 CIRCUIT CHARACTERISTICS OF THE LINE PACK

CHARACTERISTICS	AS RELATED TO THE CIRCUIT PACK
PHANTOMED POWER	30 $\pm$ 1 V divided as:
Audio Pair Level	+15 $\pm$ 0.05 v
Signaling Pair Level	-15 $\pm$ 0.05 v
POWER INPUT FROM SHELF BACKPLANE	+6, -6, +2.5 V, 30 V dc balanced



85 06

#### 4. OPERATION WITH SL-1 SET

---

##### IDLE CIRCUIT STATES

**4.01 SL-1 Set On-Hook.** Multiplex control generates and sends scan message to SL-1 set (2.5 ms message every 10 ms). Message is sent via the signaling pair and hybrid transformer (Fig. 4-1).

- (1) Message detected by Scan and Signal Distributor (**SSD**). (See Fig. 4-2 and 4-3.)
- (2) No message is being sent to line circuit on signaling pair.
- (3) In time slot 0, CE scans each line circuit on loop in sequence, detecting any change in signaling on the data input bus.
- (4) Line circuit 0 is enabled in time slot 0. Signaling on data output bus indicates that CE is ready to receive data.
- (5) No message on data input bus to CE indicates line circuit 0 is idle.

##### CALL ORIGINATED FROM AN SL-1 SET

**4.02 Originating the Call.** SL-1 is off-hook (key operated). Off-hook is detected by SSD in SL-1 set.

- (1) SSD sends off-hook signaling to line circuit on signaling pair at 2.37K bit/s when scanned by message from multiplex control.
- (2) Off-hook message from line circuit 0 is multiplexed with messages from other line circuits and sent at a rate of 64K bit/s to the CE.
- (3) CE line scan detects change in signaling for line circuit 0.
- (4) CE line scan stops.
- (5) For the next 31 times, time slot 0 signaling message is sent to CE on data input bus from line circuit 0, then line scan continues.
- (6) CE detects signaling from line circuit 0 and determines circuit number (TN number).
- (7) CE assigns message time slot to line circuit from time slots 2 through 31.
- (8) Signaling from CE is applied to the SL-1 set or console on signaling pair. Rate is changed from 64K bit/s to 2.37K bit/s by multiplex control.
- (9) Signaling is detected by SSD.
- (10) SL-1 set directory number lamp is lit.
- (11) PCM codec is enabled during message time slot assigned by CE.
- (12) Dial tone on the data output bus is applied to SL-1 set via multiplex control, PCM codec, digital-to-analog filter, hybrid transformer and audio pair (during message time slot).
- (13) Dialed information from SL-1 set on signaling pair is applied to the data input bus during time slot 0 (signaling).

- (14) CE detects dialing and removes dial tone at start of dialing.
- (15) CE encodes dialed information.
- (16) Ringback tone on the dam output bus is applied to SL-1 set over audio pair during message time slot assigned by CE (busy tone received if called number is busy).

**4.03 Talking Connection.** Called number answers.

- (1) Ringback tone is removed by CE.
- (2) Digital voice on dam output bus is applied to SL-1 set via multiplex control, PCM codec, digital-to-analog filter, hybrid transformer and audio pair during message time slot.
- (3) Analog voice on audio pair from SL-1 set is applied to dam input bus via hybrid transformer, analog-to-digital filter, PCM codec, multiplex control, and buffer (during time slot).

**4.04 Terminating the Call.** Assume SL-1 set goes on-hook first.

- (1) On-hook message is transmitted from set to line circuit.
- (2) Signaling on data output bus changes: SL-1 set lamp extinguishes.
- (3) ADD inputs removed (no signaling for line circuit 0).
- (4) Line circuit enable inputs are removed (message time slot is no longer assigned to line circuit).
- (5) Circuitry in IDLE condition, ready for next call.

**CALL TO SL-1 SET**

**4.05 Signaling to the Terminal.** In time slot 0, CE scans each line on the loop-in sequence.

- (1) CE has call for line circuit 0.
- (2) CE determines line circuit 0 is idle (no signaling from circuit on data input bus during time slot 0).
- (3) CE assigns message time slot for audible signaling (from time slots 1 through 31).
- (4) Line circuit is enabled during time slot 0.
- (5) Visual signaling data on data output bus during time slot 0 is applied to multiplex control. Visual signaling data is applied to SL-1 set over signaling pair.
- (6) Signaling is detected by SSD (Line lamp of SL-1 set flashes).
- (7) PCM codec is enabled during message time slot.
- (8) Audible signaling applied to SL-1 set via digital-to-analog filter, hybrid transformer and audio pair.
- (9) SL-1 set signaled audibly (tone ringing).



8888 1 1 1

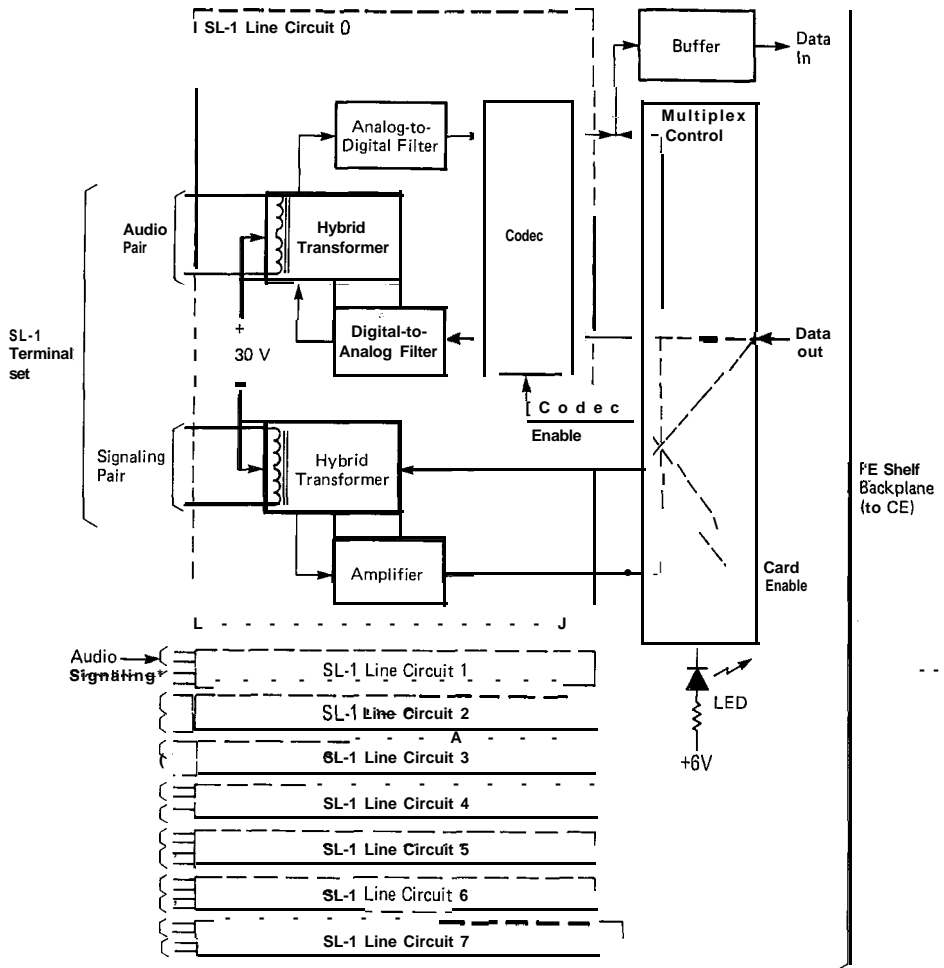

Fig. 4-1  
Simplified Functional Block Diagram of Line Circuit Pack



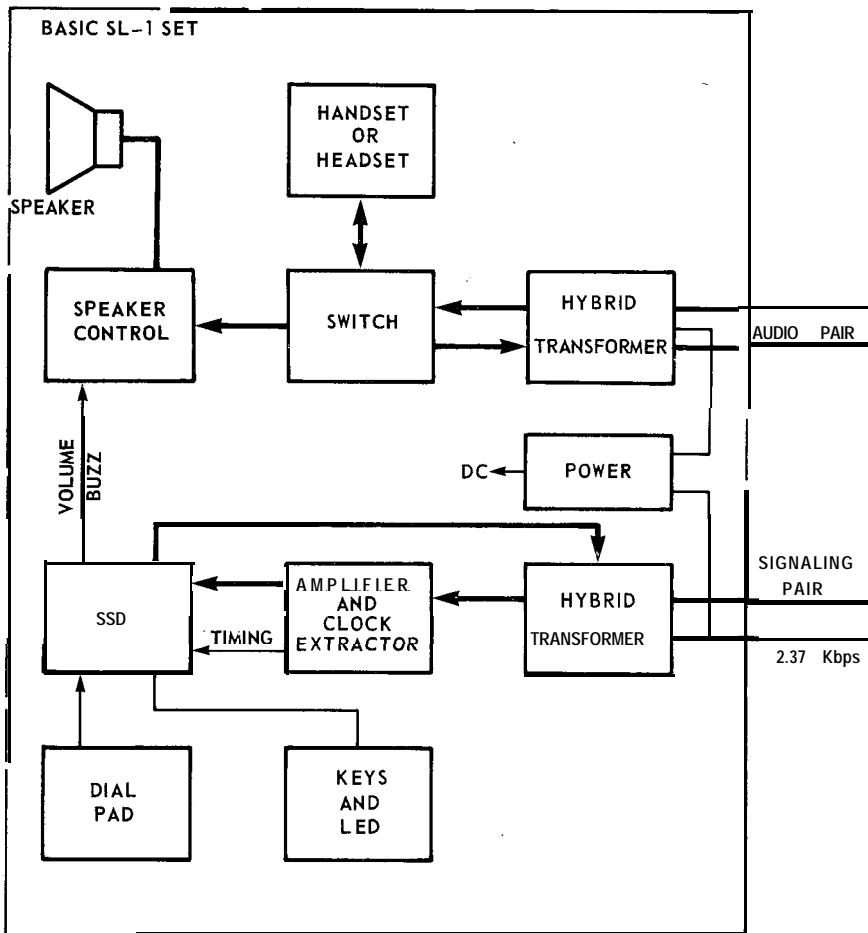

Fig. 4-2  
SL-1 Line Circuit Connected to Basic SL-1 Set

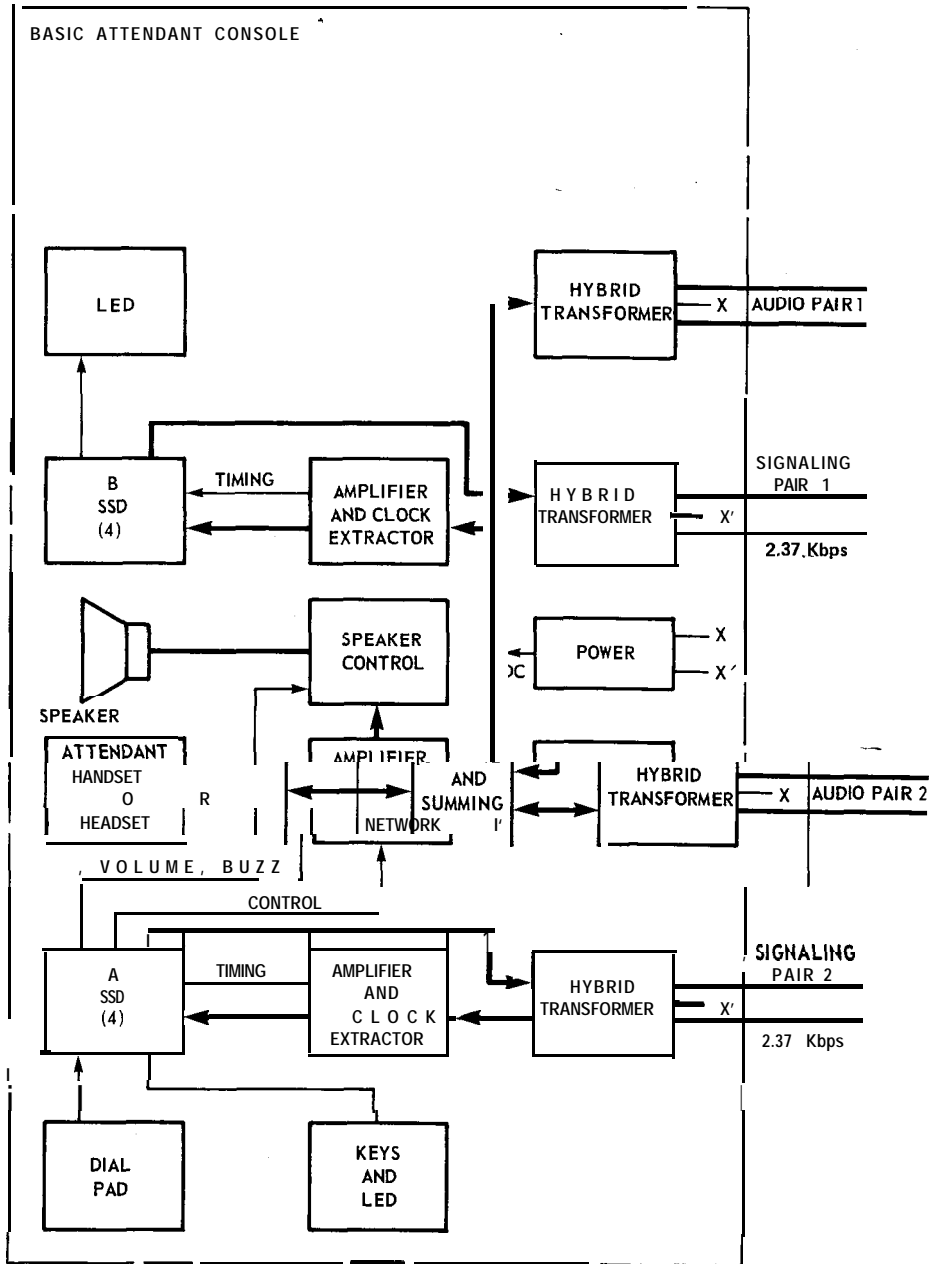

Fig. 4-3 Console Line Circuit Connected to Basic Attendant Console

**4.06 Terminal Answers.** SSD in SL-1 set sends off-hook signaling to line circuit on signaling pair.

- (1) Off-hook signaling data on data input bus during time slot 0 (via multiplex control and buffer).
- (2) CE detects signaling.
- (3) CE changes visual signaling on data output bus during time slot 0. Visual signaling is applied to SL-1 set on signaling pair. Line lamp of SL-1 set changes from flashing to steady light.
- (4) CE removes audible signaling from data output bus during message time slot (message time slot now assigned for voice communications).
- (5) Audible signaling at SL-1 set stops.

**4.07 Talking Connection.** PCM codec is enabled during message time slot.

- (1) Digital voice on data output bus is applied to SL-1 set via multiplex control, PCM codec, digital-to-analog filter, hybrid transformer, and audio pair.
- (2) Analog voice from SL-1 set is applied to data input bus via audio pair, hybrid transformer, analog-to-digital filter, PCM codec, multiplex control, and buffer.

**4.08 Terminating the Call.** Assume SL-1 is put on-hook first.

- (1) SSD transmits on-hook message to line circuit.
- (2) On-hook message transmitted to CE through data input bus during time slot 0 at a rate of 64K bit/s.
- (3) CE detects a change in signaling.
- (4) Signaling on data output bus changes; SL-1 set line lamp extinguishes.
- (5) ADD inputs are removed (no signaling for line circuit 0).
- (6) Enable inputs are removed (message time slot no longer is assigned to line circuit 0).
- (7) Circuitry in IDLE condition: ready for next call.

**CLASS-OF-SERVICE  
AND FEATURES**

4.09 All calls originating from and terminating on stations connected to line and trunk circuits may be controlled with or without attendant assistance. Call restrictions to the exchange network and special services, are assigned through unique station/line circuit data blocks contained in the system memory. Similarly, feature assignments are arranged through the same data blocks. Refer to 553-2YY1-105 for a complete list and description of features and services. Refer to 553-2YY1-310 for a description of how features and services are created in the system memory.

5. DESIGN CONSIDERATIONS

---

**FOREIGN AND SURGE  
VOLTAGE PROTECTION**

5.01 When telephone lines connected to the line circuit are exposed to foreign voltages by direct contact or induction (e.g., power line crosses or lightning), protection devices must be installed on the customer's premises. These devices must be capable of providing a path to ground from tip to ring for foreign voltages that exceed 600 V peak.

**OVERLOAD LEVEL**

5.02 Signal levels exceeding **+7 dBm** applied to the tip and ring will cause distortion in the system.



INTEGRATED SERVICES NETWORK

**MERIDIAN SL-1\***

**500/2500 LINE PACKS**  
DESCRIPTION AND OPERATION

CONTENTS	PAGE
1. GENERAL .....	1-1
2. DESCRIPTION 2 -	1
3. APPLICATION	3-1
4. CHARACTERISTICS	4-1
Functional .....	4-1
Technical Summary	4-3
Limitations	4-4
Power Requirements	4-4
Environmental	4-6
Foreign and Surge Voltage Protection	4-6
Overload Level	4-6
5. OPERATION	5-1
Idle Circuit State	5-1
Call Originated from a 500/2500 Telephone	5-1
Call to Telephone	5-2
Message Waiting Lamp Operation	5-3
Ground Button Operation	5-4
Class of Service and Features	5-5

**Reason for Reissue:** This practice is reissued to include information related to the QPC789 16-Port Message Waiting 500/2500 Line circuit pack. Changes are indicated by margin arrows. ←

\* SL-1 and Meridian are trademarks of Northern Telecom



## 1. GENERAL

---

**1.01** This practice outlines the characteristics, application and operation of the **500/2500** line circuit packs. The information is intended to be used as a guide when connecting customer-provided apparatus to the line circuit.

**1.02** The following **500/2500** line packs are available:

- QPC192 - Off-Premise Extension (OPX) Line pack ( $\mu$ -Law)
- QPC292 - Off-Premise Extension (OPX) Line pack (A-Law)
- QPC452 - Basic 500/2500 Line pack for  $\mu$ -Law applications
- QPC494 - Message Waiting Line pack ( $\mu$ -Law)
- QPC521 - Basic 500/2500 Line pack for A-Law applications
- QPC532 - Ground Button Recall Line pack (A-Law and  $\mu$ -Law)
- QPC558 - Message Waiting Line pack (A-Law)
- QPC594 - 16-Port Basic 500/2500 Line pack ( $\mu$ -Law)
- QPC681 - Parallel Message Waiting Line pack ( $\mu$ -Law)
- QPC682 - Parallel Message Waiting Line pack (A-Law).
- QPC729 - 16-Port Basic 500/2500 Line pack (A-Law)
- QPC789 - 16-Port Message Waiting 500/2500 Line pack ( $\mu$ -Law) ←





## 2. DESCRIPTION

---

2.01 All versions of the **500/2500** line packs provide talk battery and signaling for regular 2-wire common battery **500-type** (rotary dial), **2500-type (DIGITONE\*** dial) telephones and key telephone equipment. The various special versions serve additional purposes as described in Part 4.

2.02 The line circuit packs mount in a Peripheral Equipment (**PE**) shelf. The circuits connect with the switching system and with the external apparatus via an 80-pin connector at the rear of the pack. The pack is 318 mm (12.5 in) in height and 254 mm (10 in) in depth.

2.03 The 80-pin connector plugs into an IO-line bus system on the back of the PE shelf. These 80 bus lines feed into seven multi-pin connectors. Seven connectors link the line circuits to the cross-connect terminal; two faceplate connectors on the Peripheral Buffer link the PE shelves to each other and to the Common Equipment (**CE**); and one connector feeds power to the PE from the converter shelf.

2.04 Connection to the station apparatus is made at the cross-connecting terminal, as shown in the following block diagram of the line circuit connected to a **500/2500** telephone:

\* **DIGITONE** is a trademark of Northern Telecom



### 3. APPLICATION

3.01 The line circuit interfaces and is compatible with the equipment listed in Table 3-A.

**Table 3-A**  
**LINE CIRCUIT APPLICATION AND COMPATIBILITY**

EQUIPMENT	SPECIFICATIONS
NE-500 TYPE ROTARY DIAL SETS (or equivalent)	
Dial Speed	8.0 to 12.0 pps
Percent Break	58 to 69%
Interdigital Time	240 ms
NE-2500 TYPE DIGITONE SETS (or equivalent)	
Frequency Accuracy	±1.5 %
Pulse Duration	40 ms
Interdigital Time	40 ms
Speed	12.5 digits/s
KEY TELEPHONE EQUIPMENT	NE-1A1, NE-1A2, or equivalent
RECORDED ANNOUNCEMENT	*CODE-A-PHONE 200 VCA RDY (unattended telephone answering set)
DIAL LONG LINE CIRCUIT	J99234T-2/SD96555-01
LOOP EXTENDERS	Various
24V4 REPEATERS	598615 AJ-1/SD97747-01 598615 BJ-1/SD97747-01

\* CODE-A-PHONE is a trademark of Ford Industries Inc



1



## 4. CHARACTERISTICS

---

### FUNCTIONAL

#### Common Features

4.01 The following features are provided:

- 600 $\Omega$  balanced terminating impedance
- -48 V through a battery feed resistance and ground
- supervise the loop current to determine on-hook/off-hook status
- ringing current to the loop
- isolation of foreign potentials on the loop from the transmission and signaling circuit
- conversion from a 2- to a 4-wire transmission path
- analog-to-digital and digital-to-analog conversion of transmission signals
- common multiplexing' circuit to interface with the peripheral bus signaling channel
- retime the digital signals received from the peripheral bus
- decode address information received from the peripheral bus to enable individual line circuits during selected time slots
- control the disconnection timing of ringing current to the loops to avoid switching during current peaks.

#### Unique Features

4.02 The various special versions of the 500/2500 line pack have additional features as follows:

##### 4.03 QPC192 and QPC292 OPX Line packs:

- serve lines up to a maximum loop resistance of 1400  $\Omega$
- serve Dataphone sets
- have line-to-line insertion loss of 1 dB.

##### 4.04 QPC494 and QPC558 Message Waiting Line packs:

- provides connection of -150 V in a steady or 1 Hz flash rate to activate the Message Waiting lamp on the telephone
- provides for one Message Waiting lamp per line
- maintain all Message Waiting lamps off and do not allow phones to ring during power-up sequence.

- generate diagnostics an “ERROR 500” message when the Message Waiting lamp is defective or the telephone is unplugged provided -150 V is present. If -150 V is missing (blown fuse) no message is generated under any condition.

**4.05 QPC681 and QPC682 Parallel Message Waiting Line packs:**

- provides the same features as the QPC494 and QPC558 Message Waiting Line packs
- provides a -48 V connection to a lamp bank.

**4.06 QPC532 Ground Button Recall Line pack:**

- provides detection of ground on tip or ring with 40 ms validation time
- strap-selectable A-Law or  $\mu$ -Law coding
- strap-selectable 0, 1, 2 or 4 dB pad in each transmission path
- impedance-matching to 3-component complex impedances
- trans hybrid balance against 3-component complex impedances.

**4.07 QPC594 and QPC729 16-Port Basic 50012500 Line Packs:**

- sixteen individual line circuits per pack.

**4.08 QPC789 16-Port Message Waiting 50012500 Line Pack:**

- sixteen message waiting individual line circuits per pack.

→  
→

**TECHNICAL SUMMARY** 4.09 A technical summary of the line circuit pack is given in Table 4-A.

**Table 4-A**  
**TECHNICAL SUMMARY OF LINE CIRCUIT PACK**

---

Impedance:	
QPC452/521, QPC494/558	600 $\Omega$
QPC594/729/789, QPC681/682	600 $\Omega$
QPC192/292	900 $\Omega$
QPC532	600 $\Omega$ , matches 3-component complex impedances
Loop Limit (excluding set):	
QPC192/292	1400 $\Omega$ at nominal -48 V
All others	1000 $\Omega$ at nominal -48 V
Leakage Resistance	
QPC532	20,000 $\Omega$
All others	30,000 $\Omega$
Ring Trip	During silent or ringing intervals
Ringing Voltage	Determined by the type of ringing generator provided in the system
Signaling	Loop start
Supervision	Normal battery conditions are continuously applied (-48 V on ring; ground on tip) --
Power input from shelf backplane	-52, -48, i-6, -6, i-2.5 V and ringing voltage: also -150 V on Message Waiting Line cards.
Insertion loss	5, $\pm 1$ dB, at 1020 Hz
Effective Gain (QPC192/292)	1.5 dB at 1020 Hz

---



➔ LIMITATIONS

4.10 The maximum number of **Ringers** that can be connected to each DN loop is shown below:

LOOP RESISTANCE	MAXIMUM NUMBER OF RINGERS	
	QPC452/QPC494 QPC521/QPC558	QPC594/QPC789 QPC729
1000	2	2
850	3	3
600	4	4
350	5	4

**Note:** Loop resistance excludes impedance of telephone sets.

4.11 Supervision limitations are given in Table 4-B.

4.12 To maintain transmission quality, the following shows the maximum number of **Voice Calls** (number of telephone sets off-hook on the same DN) recommended:

RESISTANCE (OHMS)	QPC452/QPC494 QPC521/QPC558		QPC594/QPC789 QPC729	
	17ma	20ma	17ma	20ma
	up to 40	2	2	2
41 to 100	2	1	2	1
101 to 250	2	1	1	1
251 to 1000	1	1	1	1

**Note 1:** Loop resistance **excludes** impedance of telephone sets.

**Note 2:** 17ma/20ma is the current that a typical telephone set requires in an off-hook condition.

↳

POWER REQUIREMENTS

4.13 The **QPC452, QPC521, QPC681 and QPC682 packs** have the following typical power requirements:

VOLTAGE	IDLE CURRENT (mA)	ACTIVE CURRENT (mA)
+2.5 V, ±0.5%	<0.1	<0.1
+6 V, ±1%	50	140
-6 V, ±1%	50	140
-48 V, ±3%	1	320
+52 V, ±4%	1	85

4.14 The QPC494 and QPC558 packs have the following typical power requirements:

VOLTAGE	IDLE CURRENT (mA)	ACTIVE CURRENT (mA)
-150 v, ±5%	0	30
+2.5 V, ±0.5%	<0.1	co.1
+6 V, ±1%	50	140
-6 V, ±1%	50	140
-48 v, ±3%	1	320
+52 V, ±4%	1	85

4.15 The QPC532 pack has the following typical power requirements:

VOLTAGE	IDLE CURRENT (mA)	ACTIVE CURRENT (mA)
+2.5 V, ±0.5%	<0.1	<0.1
+6 V, ±1%	50	150
-6 V, ±1%	50	150
-48 V, ±3%	1	320
+52 V, ±4%	1	85

4.15 The QPC594, QPC729 and QPC789 have the following typical power requirements:

VOLTAGE	IDLE CURRENT (mA)	ACTIVE CURRENT (mA)
+6 V, ±1%	120	300
-6 V, ±1%	120	300
-48 V, ±3%	2	550
+52 V, ±4%	2	10
-150 V, ±5%(QPC789 only)	0	20

4.17 The QPC594, QPC729 and QPC789 Quad Density Line Cards use the following configurations on a per shelf basis when used with the QPC464 buffers (note 1):

Max # of QPC594/QPC729 QPC789 per shelf	Max # of Double Density Packs per shelf	# of Empty Slots
3	7	0
4	5	1
5	3	2 (note 2)
6	1	3

Note 1: One QPC80 is required for every 5 PE shelves.



**Note 2:** The Meridian SL-1 S **QPC501** optional backplane is equipped with only 8 slots.

4.18 When the QPC594, QPC729 or QPC789 Quad Density line card is used with the QPC659 (note) Dual Loop buffer, there are no restrictions to the number of packs in a Dual Loop shelf.

**Note:** In cabinets equipped with **QSD65** Dual Loop shelves, one **QPC80** is required for every 14 PE shelves.

4.19 There are no **Thermal Restrictions** for the QPC594, QPC729 and QPC789 Quad Density line cards even though no cooling unit is available.

4

**ENVIRONMENTAL**

**4.20** The 500/2500 Line packs have the following environmental specifications:

- (a) Operating Temperature Range: 0 to 50° C, ambient.
- (b) Operating Humidity Range: 5 to 95 %.
- (c) Storage Temperature: -40 to +70° C.

**Table 4-B  
SUPERVISION LIMITATIONS**

SUPERVISION	LIMITATION
Answer	Does not reverse the battery when the terminating end answers.
Disconnect	Does not momentarily open-circuit the Tip and Ring leads or disconnect.

**FOREIGN AND SURGE  
VOLTAGE PROTECTION**

**4.21** When telephone lines connected to the line circuit are exposed to foreign voltages by direct contact or induction (e.g., power line crosses or lightning), protection devices must be installed on the customer's premises. These devices must be capable of providing a path to ground from tip and ring for foreign voltages that exceed 600 V peak.

**OVERLOAD LEVEL**

**4.22** Signal levels exceeding  $-7$  dBm applied to the tip and ring cause distortion in speech transmission.

## 5. OPERATION

---

5.01 This part contains signaling and supervision operations which apply to the line circuit during various states of operation. Refer to Fig. 5-1 for a block diagram of a typical 500/2500 line circuit, Fig. 5-2 for a block diagram of the QPC192 and QPC292 packs, and Fig. 5-3 for a block diagram of the QPC594, QPC729 and QPC789. ←

### IDLE CIRCUIT STATE

#### 5.02 The 50012500 Telephone is On-Hook:

- No current is drawn from the -48 V supply.
- Off-hook detector continuously monitors the state of the 500/2500 line.
- In time slot 0, the CE scans each line circuit on the loop in sequence, detecting any change in signaling on the data input bus.
- In time slot 0, the circuit is enabled. Signaling on the data output bus indicates that the CE is ready to receive data. If no message is returned from the line circuit to CE, then line circuit is idle.

### CALL ORIGINATED FROM A 50012500 TELEPHONE

#### 5.03 Originating the Call.

- (1) Telephone goes off-hook.
- (2) Current is drawn from the -48 V supply.
- (3) Off-hook state is detected by off-hook detector.
- (4) Multiplex control sends off-hook signaling to CE on data input-bus during time slot 0 (via the buffer).
- (5) CE detects signaling from line circuit and determines circuit number (terminal number).
- (6) CE assigns message time slot to line circuit (from time slots 2 to 31)
- (7) The line circuit and PCM codec are enabled during the message time slot assigned to the line circuit.
- (8) CE applies dial tone (during message time slot) to telephone via data output bus, multiplex control, digital-to-analog filter and hybrid transformer.
- (9) Dialed information from telephone is applied to data input bus during time slot 0 (signaling).
- (10) CE detects dialing and removes dial tone at start of dialing.
- (11) CE decodes dialed information.

- (12) Ringback tone on the data output bus is applied to telephone during message time slot assigned by CE (busy tone received if called number is busy).

#### 5.04 Talking Connection.

- (1) Called party answers.
- (2) Ringback tone removed by CE.
- (3) During message time slot, digital voice on data output bus is applied to telephone via multiplex control, PCM codec, digital-to-analog filter and hybrid transformer.
- (4) During the message time slot, analog voice from telephone is applied to the data input bus via hybrid transformer, analog-to-digital filter, PCM codec, multiplex control and buffer.

#### 5.05 Terminating Call.

- (1) Telephone goes on-hook.
- (2) On-hook condition is detected by off-hook detector.
- (3) Message sent to CE.
- (4) CE detects removal of signaling.
- (5) The circuit enable inputs are removed and the message time slot is no longer assigned to the line circuit.
- (6) Circuitry in 'idle' condition, ready for next call.

### CALL TO TELEPHONE

#### 5.06 Signaling the Called Telephone.

- (1) CE is continuously monitoring the status of line circuit (time slot 0 signaling).
- (2) CE has call for line circuit 0.
- (3) CE determines that line circuit 0 is idle (no signaling from circuit on the data input bus during time slot 0).
- (4) Signaling on the data output bus during time slot 0 is applied to multiplex control.
- (5) Ring Control (RC) signal from the multiplex control energizes circuit at the rate determined by software.
- (6) The 20 Hz ringing is applied to the 500/2500 telephone via K1 make-contacts and hybrid transformer.

#### 5.07 Called Telephone Answers.

- (1) Telephone goes off-hook, closing loop.
- (2) Off-hook condition is detected by the off-hook detector during the silent or ringing interval.

- (3) Ring **control** signal is removed.. Relay **K1** is deenergized.
- (4) Ringing voltage is removed from called telephone.
- (5) Multiplex control sends off-hook signaling data to CE on the data input bus during time slot 0.
- (6) CE detects signaling.
- (7) **CE removes** ringing signaling on the data output bus during time slot 0.

#### 5.08 Talking Connection.

- (1) Circuit and codec enable inputs are received during message time slot assigned by CE.
- (2) During message time slot, digital voice on the data output bus is applied to the telephone via multiplex control, PCM **codec**, digital-to-analog filter and hybrid transformer.
- (3) During message time slot, analog voice from telephone is applied to the data input bus via hybrid transformer, analog-to-digital filter, PCM codec, multiplex control and buffer.

#### 5.09 Terminating the Call.

- (1) Called telephone goes on-hook.
- (2) On-hook condition detected by off-hook detector.
- (3) No signaling on the data input bus during time slot 0.
- (4) CE detects removal of signaling.
- (5) Signaling for line circuit is removed from data output bus.
- (6) Circuit enable inputs removed (message time slot is no longer assigned to line circuit 0).
- (7) Circuitry in 'idle' condition, ready for next call.

### MESSAGE WAITING LAMP OPERATION

#### 5.10 Message Waiting Lamp Activation.

- (1) Telephone idle.
- (2) CE receives a signal from the message center and sends it to the message waiting line circuit.
- (3) The message waiting lamp control on the message waiting line circuit places -150 V across tip and ring to light the lamp at the telephone and -48 V **across** -48 V and GND pair to the lamp bank.
- (4) Telephone goes off -hook.

- (5) The off-hook condition is detected by the line circuit and the lamp control removes the -150 V from the tip and ring of the telephone. The message waiting lamp is deactivated.
- (6) Telephone goes on-hook.
- (7) The on-hook condition is detected by the line circuit, the lamp control places -150 V on the tip and ring of the telephone and restores the message waiting lamp to the lit state.

**5.11 Message Waiting Lamp Cancellation from Telephone.**

- (1) Telephone originates a call to the message center.
- (2) The off-hook condition is detected by the message waiting line circuit and the lamps at the telephone and at the lamp bank are deactivated.
- (3) The message center answers.
- (4) The CE signals the line circuit and the message lamp control cancels the message waiting condition.
- (5) Telephone goes on-hook.
- (6) Message waiting lamp remains unlit.

**5.12 Message Waiting Lamp Cancellation from Message Center.**

- (1) The CE receives a signal from the message center to cancel the message waiting condition.
- (2) The message waiting line circuit receives the signal from the CE and the message waiting lamp control removes the -150 V from the tip and ring of the telephone and the -48 V from the lamp bank.
- (3) The lamp is deactivated and the message waiting condition is cancelled.

--

**GROUND BUTTON  
OPERATION**

**5.13 Ground Button Depressed While on an Established Call:**

- (1) Ground button detector on the QPC532 sends a 'ground detected signal to the scan and signal distributor.
- (2) The SSD encodes a signal and sends it to the central processing unit (CPU).
- (3) The CPU provides a special tone to the party that depressed the ground button and places the other party on hold.

**CLASS OF SERVICE  
AND FEATURES**

5.14 All calls originating from and terminating on stations connected to line and trunk circuits may be controlled with or without attendant assistance. Call restrictions to the exchange network and special services are assigned through unique station/line circuit data blocks contained in the system memory. Similarly, feature assignments are arranged through the same data blocks. Refer to **552-2YY1-105** for a complete list and description of features and services. Refer to **552-2YY1-310** for a description of how features and **services** are created in the system memory.



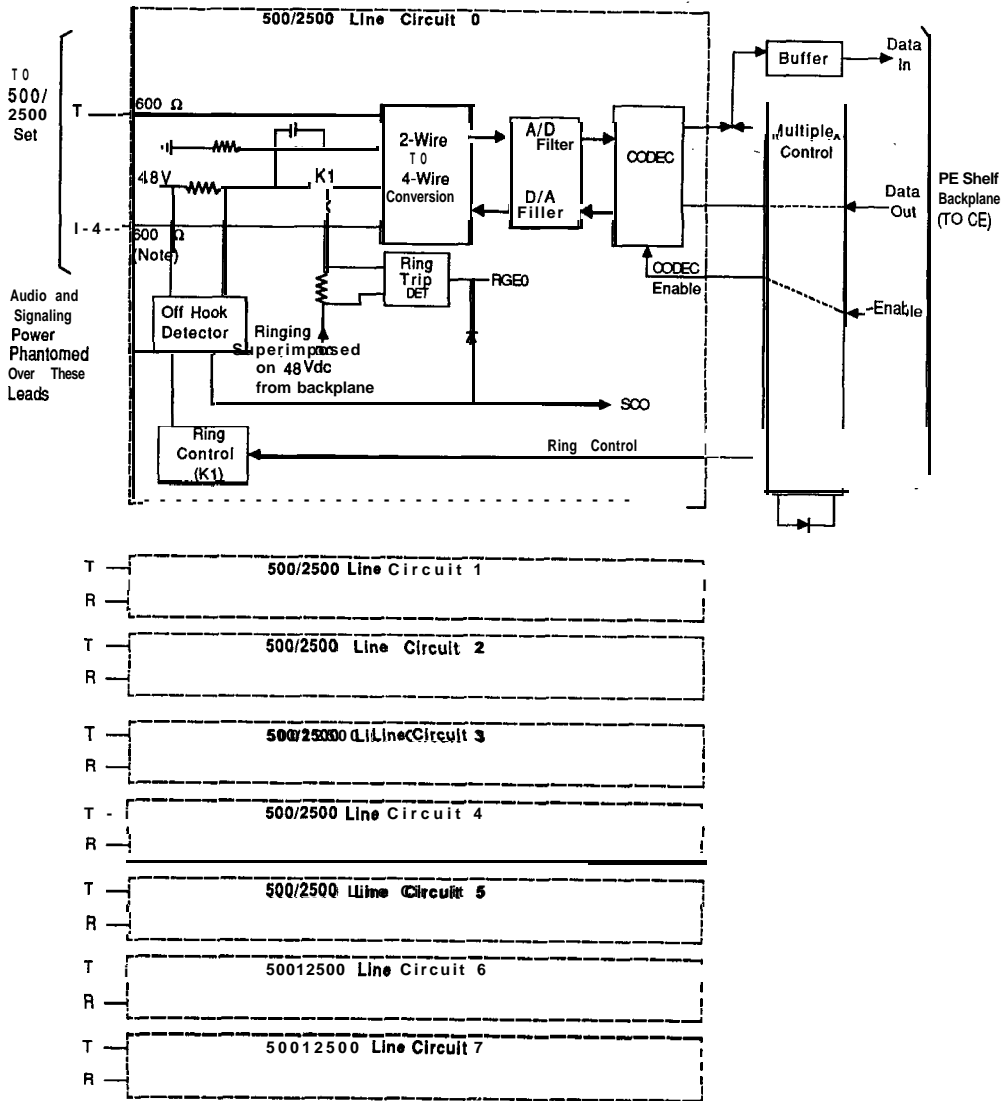

(III.553-1471)

Note: QPC532 matches 3 component complex impedance.

Fig. 5-1  
 → Block Diagram of a double density 50012500 Line Pack

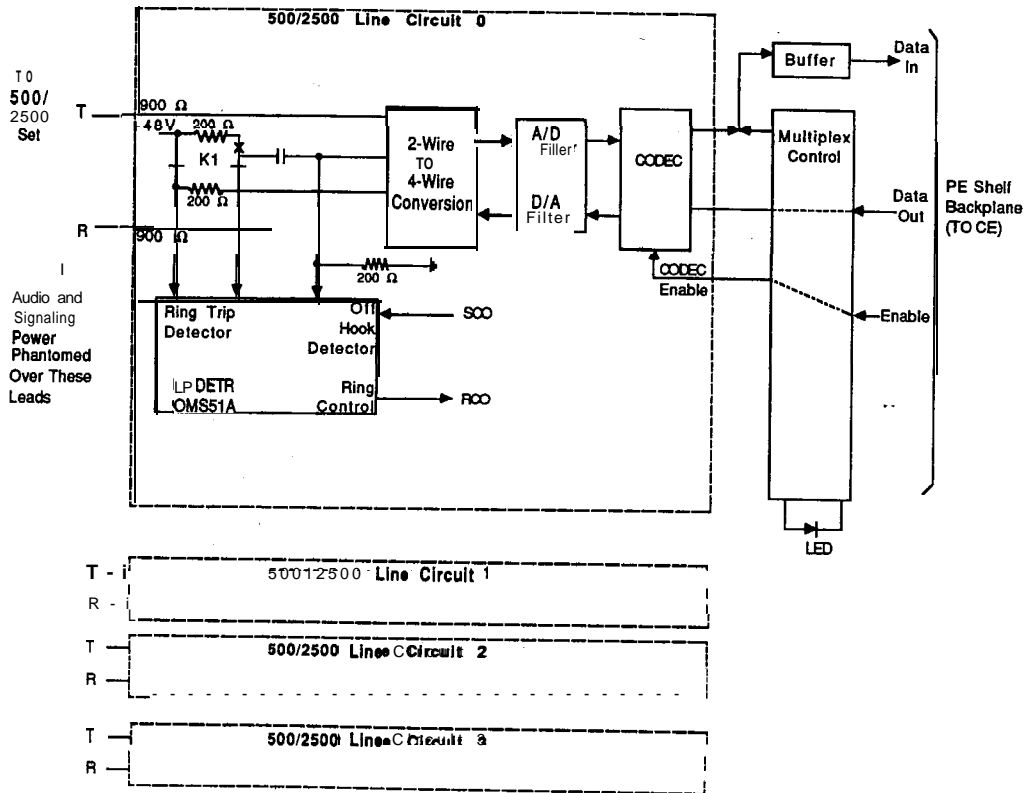

**Note:** A ringing value may differ depending upon type of ringing generator pack used.

GRD, -48V, ±10V, ±6V — Power  
 85V rms 20 Hz (Note) — Ringing  
 Superimposed on -48V dc

(III.553-1472)

**Fig. 5-2**  
**Block Diagram of QPC192/292 Line Pack**

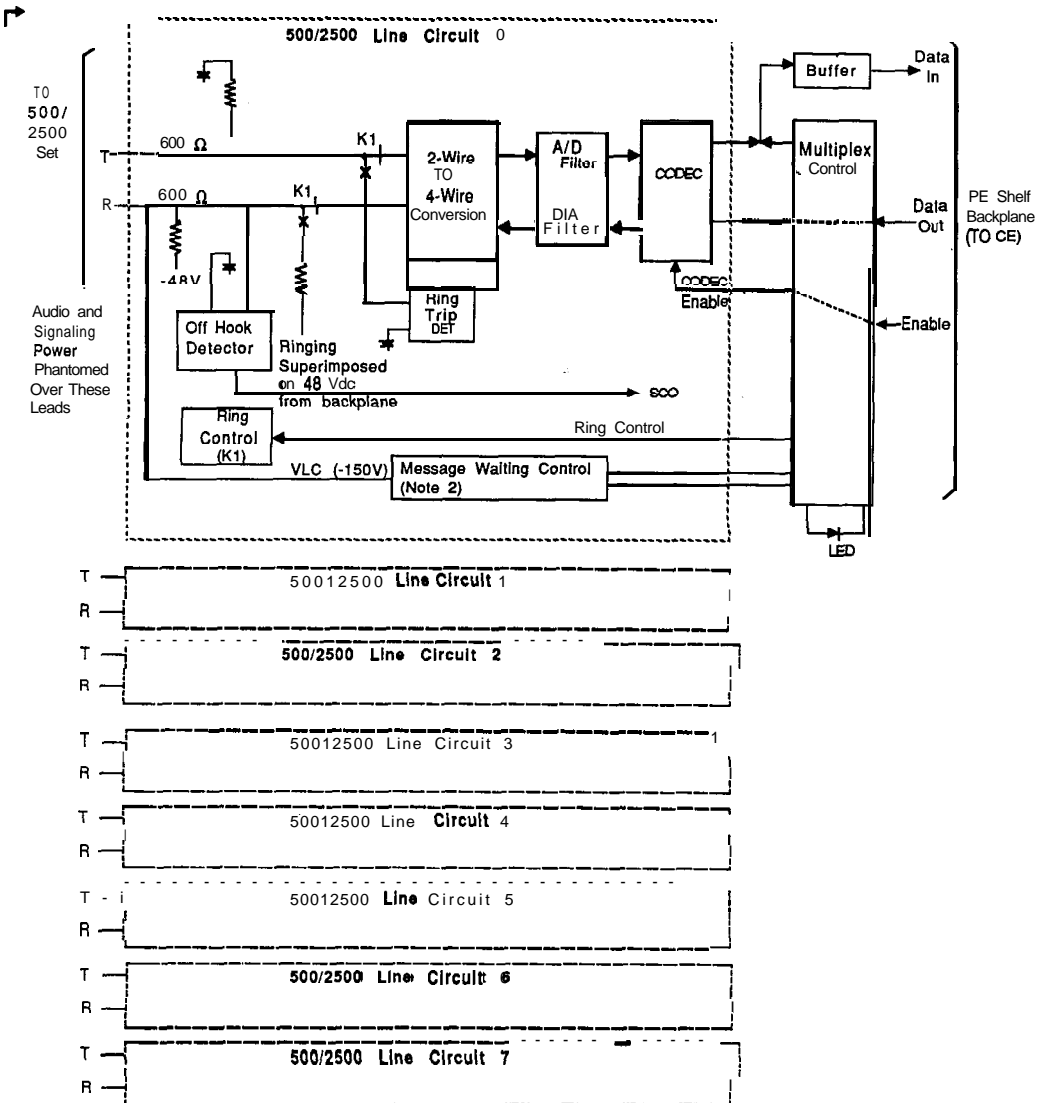

**Note 1:** There is an additional 8 line circuits (line circuits 6-15) on the QPC594/QPC729/QPC789 16-port line cards.

**Note 2:** This circuitry is only supplied on the QPC789 circuit Packs.

(III.553-1470)

**Fig. 5-3**  
 ↳ **Block Diagram of QPC594/729/789 Line Pack**

---

INTEGRATED SERVICES NETWORK

# MERIDIAN SL-1\*

QPC578 INTEGRATED SERVICES DIGITAL LINE CARD

DESCRIPTION

---

CONTENTS	PAGE
1. QPC578 INTEGRATED SERVICES DIGITAL LINE CARD	I-I
Description	1-1
F u n c t i o n s . . . . .	2

**Reason for Reissue:** This practice is reissued to add further reference information on digital telephones. Changes are indicated by arrows in the margin.

\*Meridian and SL-1 are trademarks of Northern Telecom



## 1. QPC578 INTEGRATED SERVICES DIGITAL LINE CARD

---

**1.01** The QPC578 Integrated Services Digital Line Card (ISDLC) is a voice and data communication link between a Meridian SL-1 and the Meridian M2000/M3000 series of digital telephones. When a digital telephone is equipped with the data option, an asynchronous ASCII terminal or PC can be connected to Meridian SL-1 through the digital telephone. The ISDLC circuit pack supports voice only or simultaneous voice and data service over a single twisted pair of standard telephone wiring. This practice describes the ISDLC. For more information on Meridian digital telephones, see 553-2201-110 and 553-2201-111 for the M2000 series telephones, the 553-2201-115 for the M3000 telephone, and the 553-2201-113 for the M2317 telephone.

**1.02 Requirements.** To use the ISDLC, the following Meridian SL-1 requirements must be met:

- Double Density Peripheral Shelves must be equipped (one shelf per loop)
- Generic X11, Release 7 (or later) or Generic X08, Release 10 (or later) software must be running.
- Quadruple Density loops must be defined in hardware (SW5 set to ON on the associated Peripheral Buffer) and software (OVL 17)
- At remote locations using Remote Peripheral Equipment (RPE), ISDLC packs must be QPC578B, series C or higher.

### Description

**1.03** The QPC578 ISDLC is equipped with eight identical line circuits. Each line circuit provides a multiplexed voice, data and signaling path to and from digital apparatus over a 2-wire full duplex 512 KHz Time Compression Multiplexed (TCM) digital link.

**1.04 Time Compression Multiplexing.** Once every 125  $\mu$ second, the ISDLC transmits a 23 bit message to a digital telephone. At the end of the 23 bit message a 2.7 bit guard band delay is inserted. Then the digital telephone begins transmitting a similarly formatted 23 bit message to the ISDLC. Each 23 bit message consists of:

- start (1 bit)
- voice signaling (1 bit)
- voice valid (1 bit)
- PCM voice (8 bits)
- data signaling (1 bit)
- data valid (1 bit)
- data (8 bits)
- parity (1 bit)
- stop (1 bit)

**1.05 Meridian SL-i Data Block.** Each digital telephone and each associated data terminal is assigned a separate Terminal Number (TN) in the Meridian SL-1 data base.

**1.06 Physical.** ISDLc circuitry is contained on a 320 mm (12.5 in) by 254 mm (10 in) printed circuit board. The faceplate of the pack is equipped with a red LED which lights if the pack is disabled. The rear of the pack is equipped with an IO-pin connector which provides access to:

- digital telephones (and associated ASCII terminals or PCs if equipped)
- Peripheral Bus
- power supply

**1.07 Configuration.** Up to six ISDLc circuit packs can be mounted in one PE shelf if the remaining slots are used: up to eight ISDLc circuit packs can be equipped if the remaining slots are left unused. In addition, up to 18 ISDLc packs can be supported by a single QPC82 Power Converter. This assumes that no other packs exist that require power from that converter. If ISDLc circuit packs co-exist with other peripheral packs associated with the same power converter, the total number of ISDLc circuit packs is calculated as follows:

$$D = 3/4 (24 - X)$$

where

D, an integer, is the maximum number of ISDLc packs allowed

X is the number of other circuit packs (e.g., QPC451) associated with the same power converter.

**Note:** When ISDLc circuit packs serve M3000 Touchphones, this restriction does not apply because Touchphones are locally powered.

**1.06 Power Supply to Digital Telephones.** The ISDLc provides +30 VDC over each loop at a maximum current of 60 mA. The line feed interface can supply power to loops of up to 1067 m (3500 ft) length using 22 or 24 AWG gauge wire. 26 AWG gauge wire is limited to 745 m (2450 ft). Typical cabling and cross-connections are shown in Fig. 1-1.

**Functions**

**1.09** The ISDLc handles messages sent to and from Meridian SL-1 and digital telephones. Because the message formats and clocking used by Meridian SL-1 and the digital telephones are different, the ISDLc must be able to correctly format and synchronize all messages going to and from these devices. The ISDLc performs the following major tasks:

- (a) Provides 8 bidirectional BPRZ-AM1 coded TCM lines at 512 kbps to interface up to 8 digital telephones and their associated Data Options.
- (b) Multiplexes and demultiplexes 8 integrated voice and data lines and a 2.56 Mbps DS-30X data stream (used internally by ISDLc)

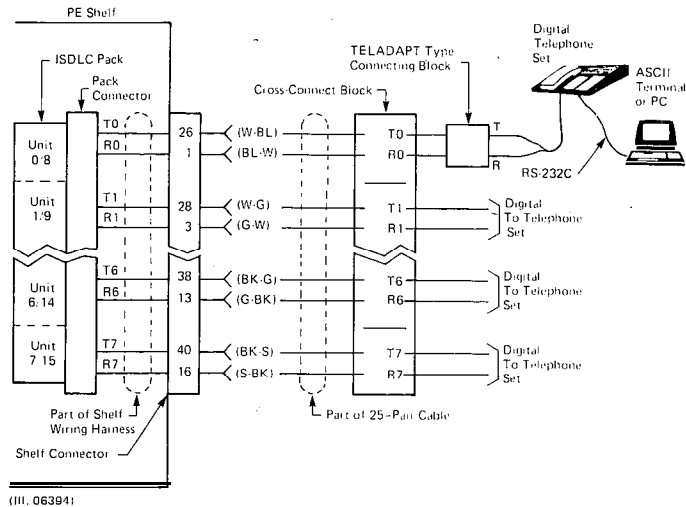

**Fig. 1-1**  
**Typical ISDL Cabling and Cross-Connections**

- (c) Converts the Meridian SL-1 bit interleaved data format to DS-30X format and vice versa.
- (d) Converts Meridian SL-1 SSD (signaling) messages to TCM format and vice versa.
- (e) Synchronizes the digital telephones and their data options to the Meridian SL-1.
- (f) Provides buffering of messages to compensate for different signaling rates

1.10 The ISDL consists of the functional blocks shown in Fig. 1-2. Each block incorporates the following main functions:

- (a) **TCM Loop interface.**
  - Couples 8 identical TCM loops from the Digital Line Interface (DLIC) functional block of the ISDL to the Digital Set Interface (DSIC) functional block located in each digital telephone in both the transmit and receive directions.
  - Provides i-30 V battery feed to each digital telephone through a voltage regulator, configured as a 60 mA constant current source.
- (b) **Digital Line Interface (DLIC).** The DLIC provides the communication link between 8 digital telephones (including their associated Data Options) and the Meridian SL-1 peripheral bus. The DLIC performs the following functions:



- Multiplexes 8 integrated voice and data TCM lines into a 2.56 Mbps DS-30X formatted data stream (used internally in the pack) when the transmission is from the digital telephone or associated terminal to the Meridian SL-1.
  - De-multiplexes the 2.56 Mbps DS-30X formatted data stream into 8 integrated voice and data TCM line-s when the transmission is from the Meridian SL-1 to the digital telephone or associated terminal.
  - Provides a station line transmitter for 8 channels, each of which transmits BPRZ-AM1 coded data over the TCM loop at 512 kbps.
  - provides 8 station line receivers, each of which receives BPRZ-AM1 data from a TCM loop independantly at 512 bps.
- (c) **Set Gate Array.** The Set Gate Array handles **signalling** conversion for up to 8 integrated voice and data lines.
- Receives signaling bits (8 voice and 8 data) from digital telephones and transfers the data in bytes via the FIFO to the Receive  $\mu$ P.
  - Accepts DS-30X signaling messages from the Transmit  $\mu$ P and inserts the packets bit by bit to the appropriate signaling channel.
- (d) **Transmit  $\mu$ Processor.** The Transmit  $\mu$ Processor receives outgoing Meridian SL-1 SSD messages (i.e., signaling) from the Peripheral Gate Array and:
- Converts outgoing SSD messages to DS-30X format.

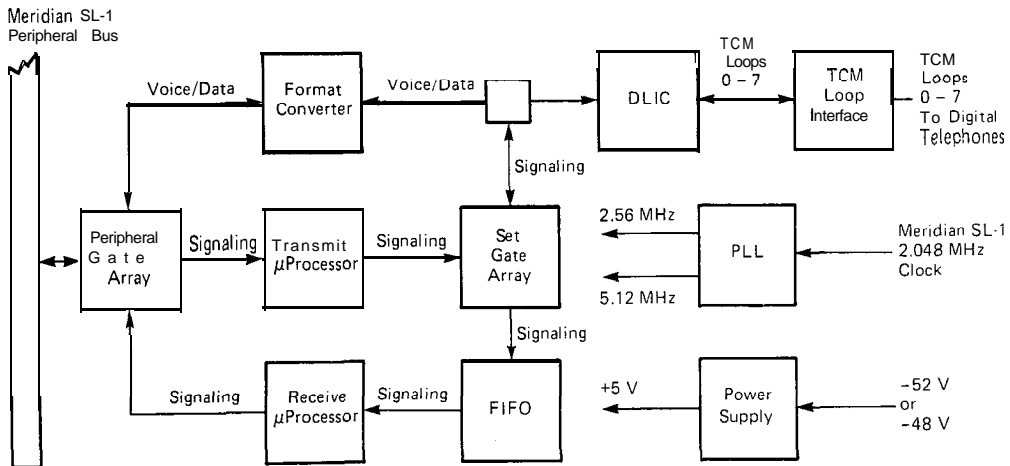

(III. 06395)

Fig. I-2  
ISDLC Block Diagram

- If required, packetizes several SSD messages into one DS-30X message.
- (e) **Receive  $\mu$ Processor.** The Receive  $\mu$ Processor receives incoming signaling messages from digital telephones, via the Set Gate Array and:
- Converts incoming DS-30X signaling messages to SSD message format.
  - Will repacketize a long message into several SSD sized (2-bytes) messages when required.
- (f) **Format Converter.**
- Converts the Meridian SL-1 voice and data bit-interleaved format to DS-30X byte-interleaved format.
  - Converts the incoming DS-30X byte-interleaved format to Meridian SL-1 bit-interleaved format.
- (g) **Peripheral Gate Array.**
- Provides a bi-directional interface for voice and data-between the Meridian SL-1 Peripheral Bus and the Format Converter.
  - Provides serial to parallel conversion of signaling data received from the Meridian SL-1 Peripheral Bus and transfers the data to the Transmit  $\mu$ P.
  - Provides parallel to serial conversion of signaling data received from the Receive  $\mu$ P and transfers the data to the Meridian SL-1 Peripheral Bus.
- (h) **Phase Locked Loop.**
- Ensures phase and frequency stability and correlation between incoming signals from the digital telephones and signals on the ISDL.
  - Three clocks, 2.56 MHz, 4.096 MHz and 5.12 MHz, are derived from the PLL and synchronized to the 2.048 MHz Meridian SL-1 clock.
- (i) **Power Supply.**
- An onboard DC-to-DC converter takes either -52 VDC or -48 VDC input and generates the -5 VDC required by the ISDL logic circuits.
  - up to 2 A with 5% regulation

Table 1-A  
ISDL C CIRCUIT CHARACTERISTICS

CHARACTERISTICS	DESCRIPTION
circuits per pack	8 voice/data
options	nil
impedance	100 $\Omega$
↳ loop limits -QPC578A and B	100 (30 m) to 3000 feet (900 m) with 24 AWG PVC cable (i-30 VDC at 60 mA)
↳ -QPC578C	0 to 3500 feet (1067 m) with 24 AWG PVC cable (i-30 VDC at 60 mA)
line rate	512 kbps $\pm$ 100 ppm
line coding	bipolar return-to-zero alternate mark inversion (BPRZ-AMI)
power supply	-52 VDC unregulated  or -48 VDC regulated  and $\pm 6$ VDC, $\pm 15$ VDC. i-10 VDC
transmitter output voltage -successive '1' bits -'0' bits	i-1.5 $\pm$ 0.15V and -1.5 $\pm$ 0.15V 0 $\pm$ 50mV