

HARRIS

DRACON DIVISION

Technical Support Group

PAGEPAC CONNECTIONS

FOR THE

PARTNER PLUS / II

JANUARY 1995

TABLE OF CONTENTS

	PAGE
PAGEPAC 6 WITH TRUNK ADAPTER	1
PAGEPAC 6 WITH PORTSAVER (ONE SHARED LINE PORT)	2
PAGEPAC 6 (PAGE VIA PAGE PORT/4-WIRE)	3
PAGEPAC 6 PLUS (ONE DEDICATED LINE PORT)	4
PAGEPAC 6 PLUS (ONE SHARED LINE PORT)	5
PAGEPAC 6 PLUS (TWO SHARED LINE PORTS)	6
PAGEPAC 6 PLUS (PAGE VIA PAGE PORT/2-WIRE)	7
PARTNER PAGEPAC	8
PAGEPAC 20 WITH TRUNK ADAPTER	9
PAGEPAC 20 (PAGE VIA PAGE PORT/4-WIRE)	10
PAGEPAC 20 AND TALKMATE WITH TRUNK ADAPTER	11
PAGEPAC 20 AND TALKMATE (PAGE VIA PAGE PORT/4-WIRE)	12
PAGEPAC 20 AND ZONEMATE	13
PAGEPAC 20 AND ZONEMATE (PAGE VIA PAGE PORT/2-WIRE)	14
PAGEPAC 20 AND ZONEMATE (PAGE VIA PAGE PORT/4-WIRE)	15
PAGEPAC VS	16
PAGEPAC VS (PAGE VIA PAGE PORT/2-WIRE)	17
PAGEPAC VS (PAGE VIA ANALOG STATION)	18
PAGEPAC 50, 100, AND 200	19
PAGEPAC 50, 100, AND 200 (PAGE VIA PAGE PORT/2-WIRE)	20
PAGEPAC 50, 100, AND 200 (PAGE VIA PAGE PORT/4-WIRE)	21
PAGEPAC 50, 100, AND 200 (PAGE VIA ANALOG STATION)	22
AMPLICENTER (PAGE VIA PAGE PORT)	23

TABLE OF CONTENTS (CONT.)

	PAGE
AMPLICENTER WITH TRUNK ADAPTER	24
PAGEPAC PLUS D-SERIES AMP. (PAGE VIA LOOP START TRUNK)	25
PAGEPAC PLUS D-SERIES AMP. (PAGE VIA PAGE PORT/2-WIRE)	26
PAGEPAC PLUS D-SERIES AMP. (PAGE VIA PAGE PORT/4-WIRE)	27
PAGEPAC PLUS D-SERIES AMP. & CONTROLLER (LOOP START TRNK)	28
PAGEPAC PLUS D-SERIES AMP. & CONTROLLER (PAGE PORT/2-WIRE)	29
PAGEPAC PLUS D-SERIES AMP. & CONTROLLER (PAGE PORT/4-WIRE)	30
PAGEPAC PLUS D-SERIES AMP. & CONTROLLER (ANALOG STATION)	31

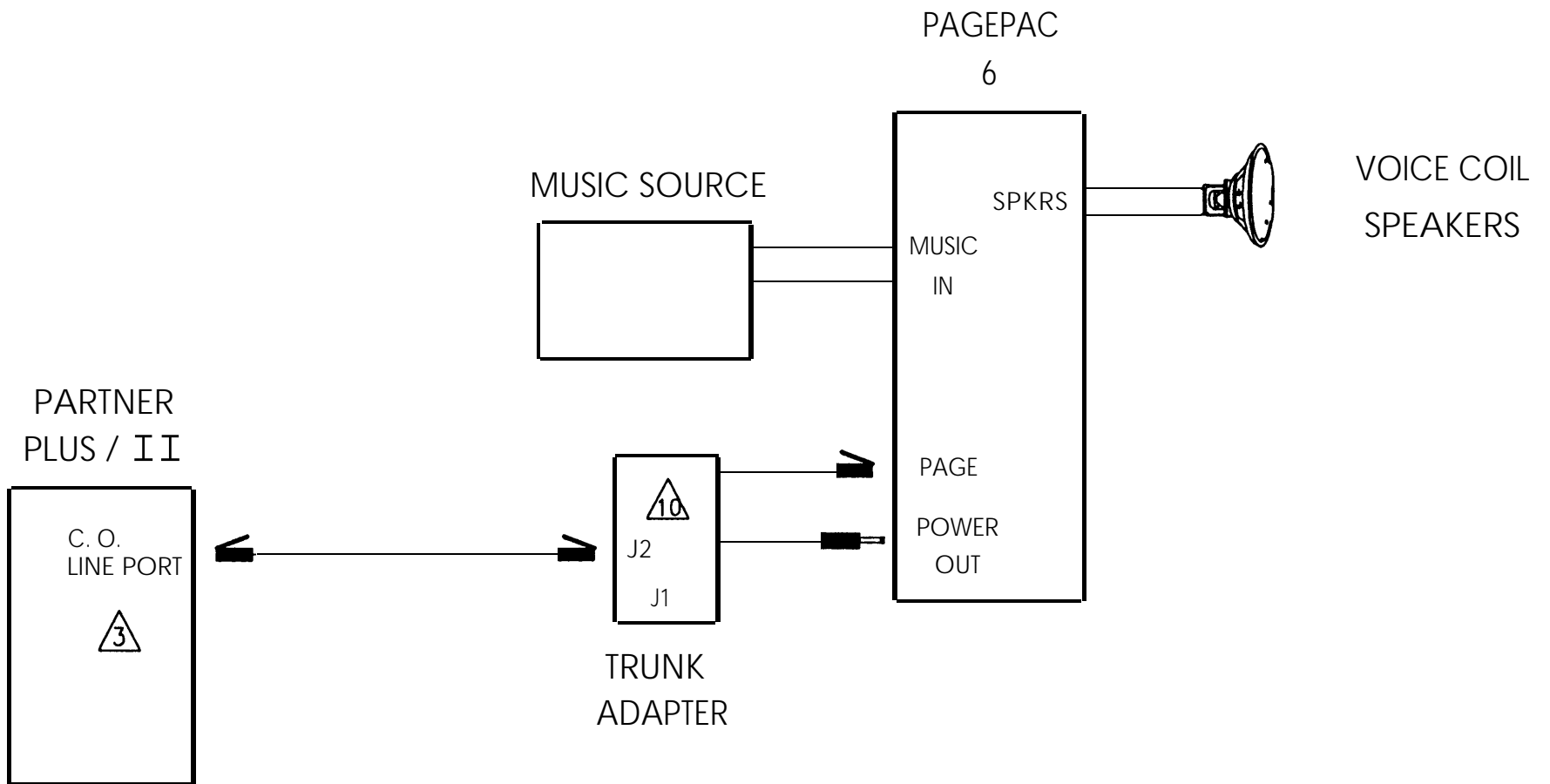

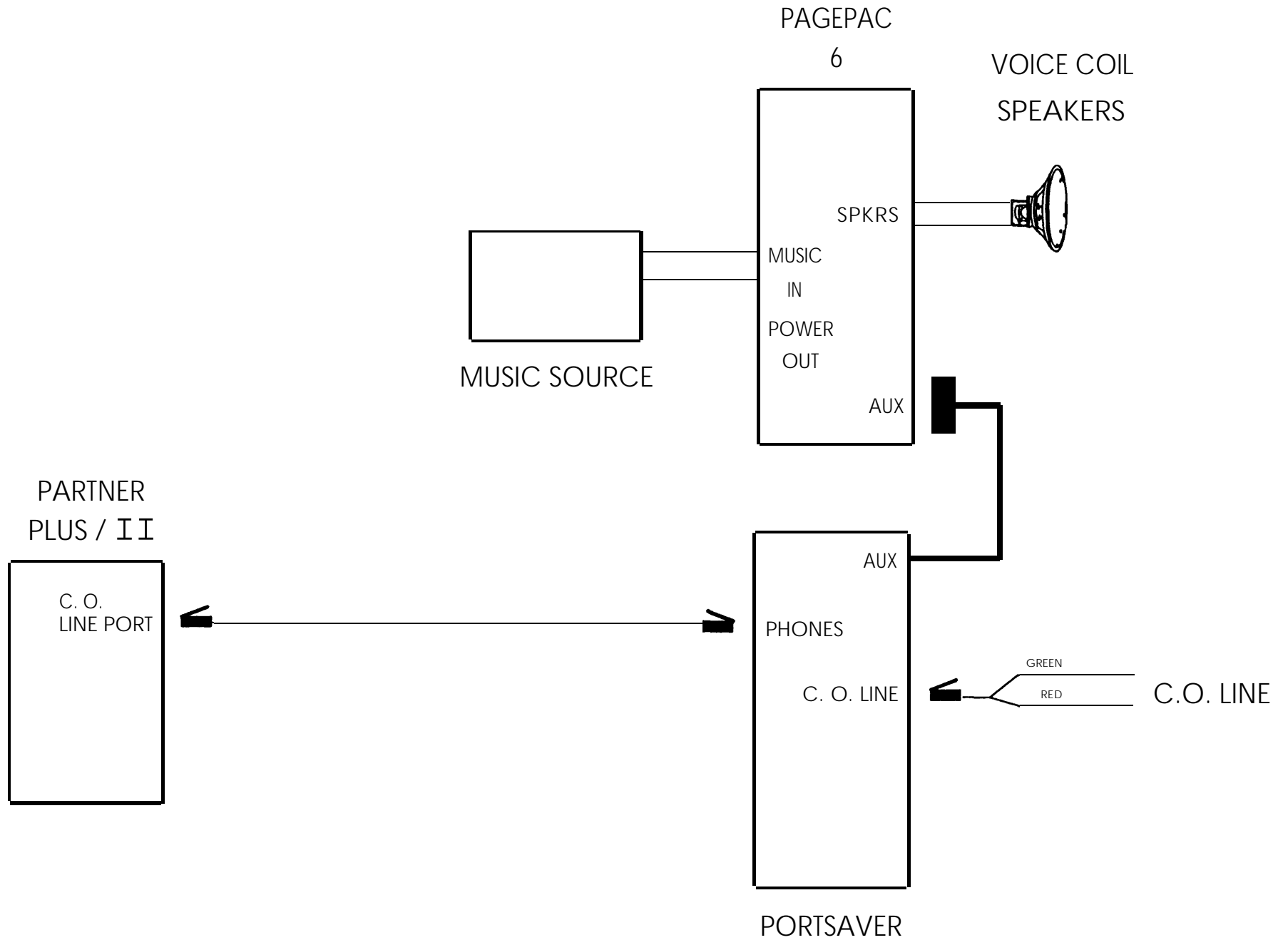

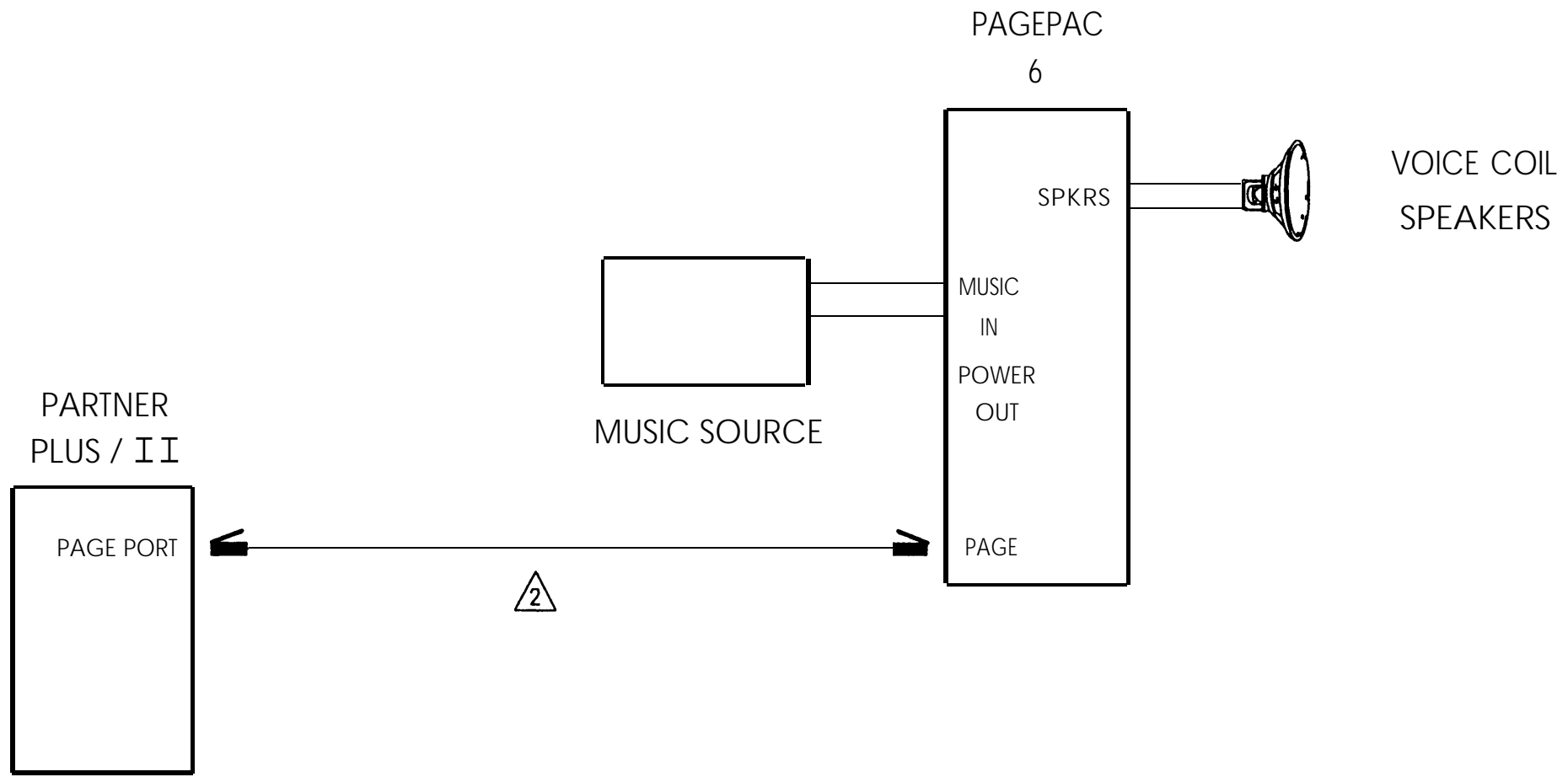

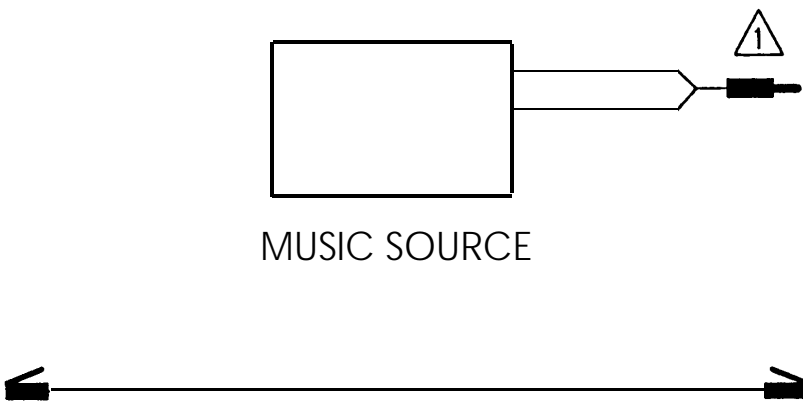
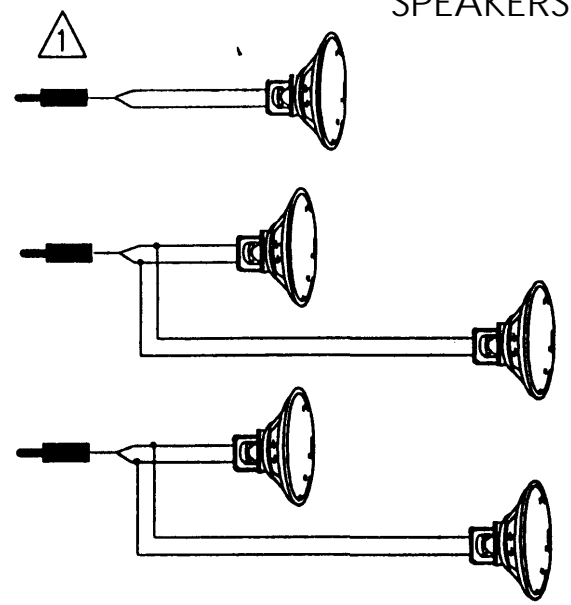
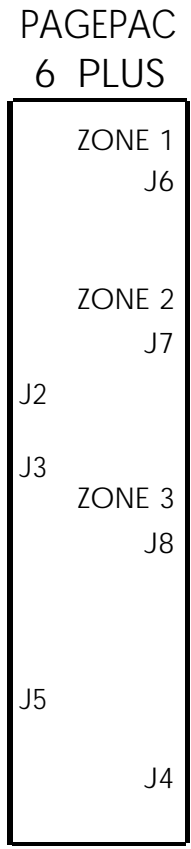
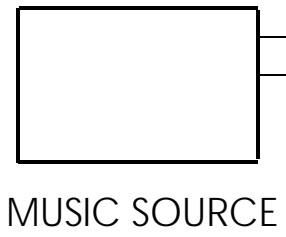
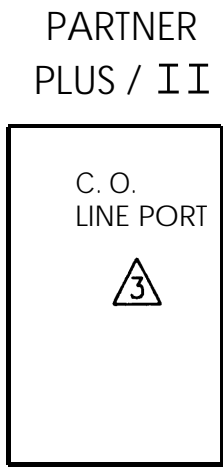

PARTNER PLUS / II

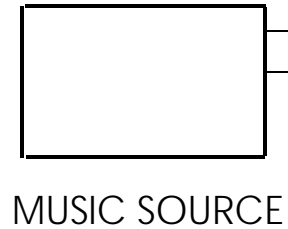
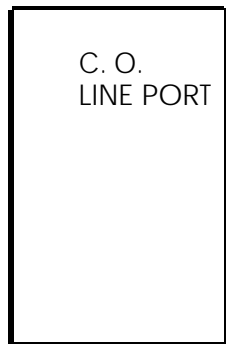

PAGEPAC 6 PLUS

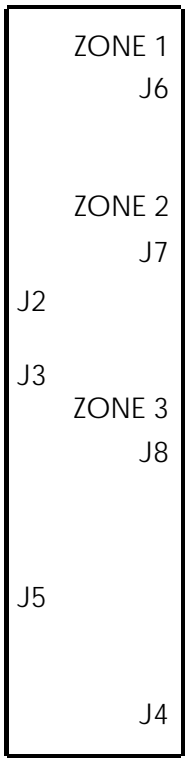

VOICE COIL SPEAKERS

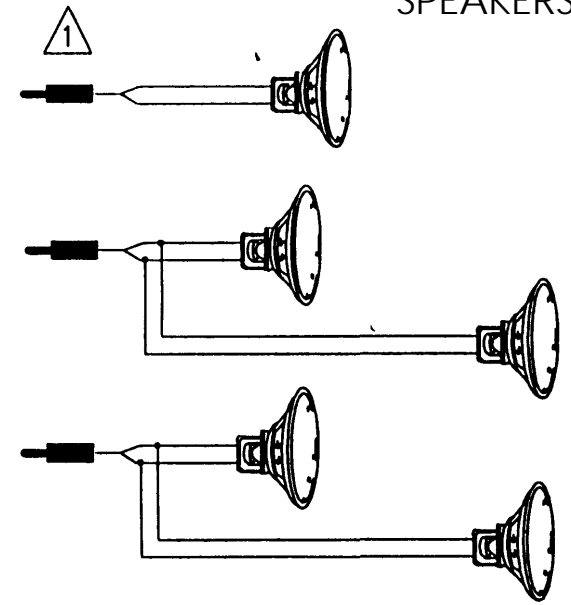

PARTNER PLUS / II

MUSIC SOURCE

PAGEPAC 6 PLUS

VOICE COIL SPEAKERS

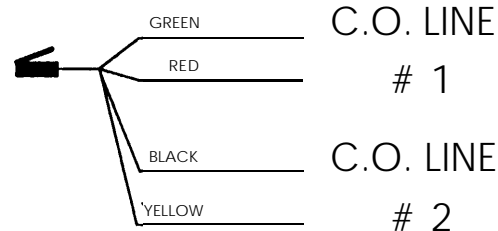
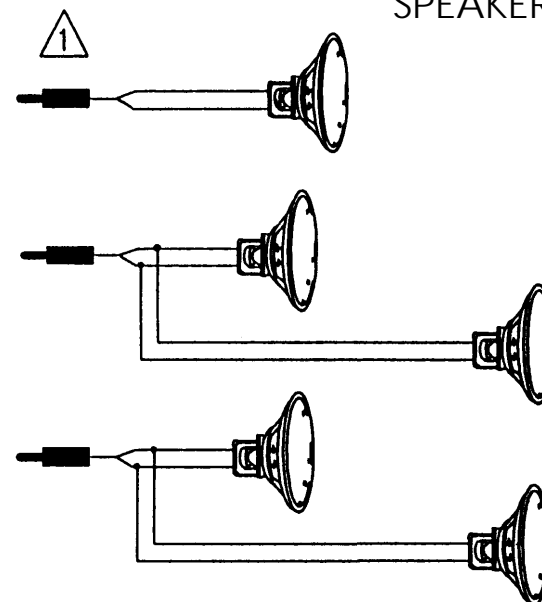
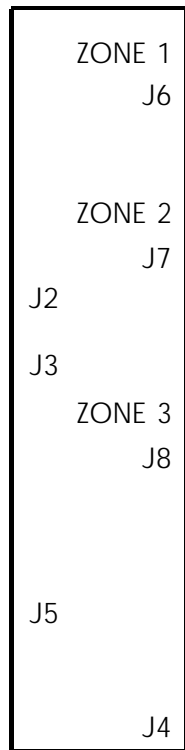
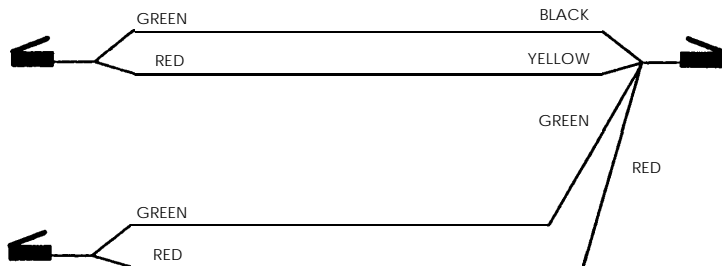
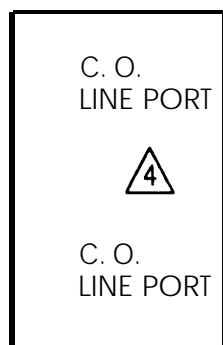

PARTNER PLUS / II



MUSIC SOURCE

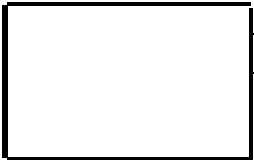

PAGEPAC 6 PLUS

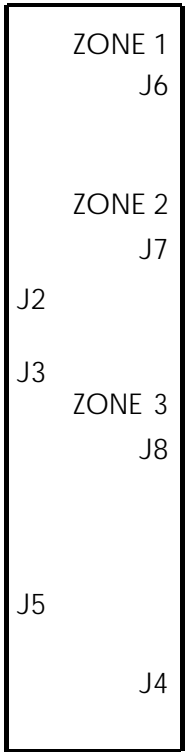

VOICE COIL SPEAKERS

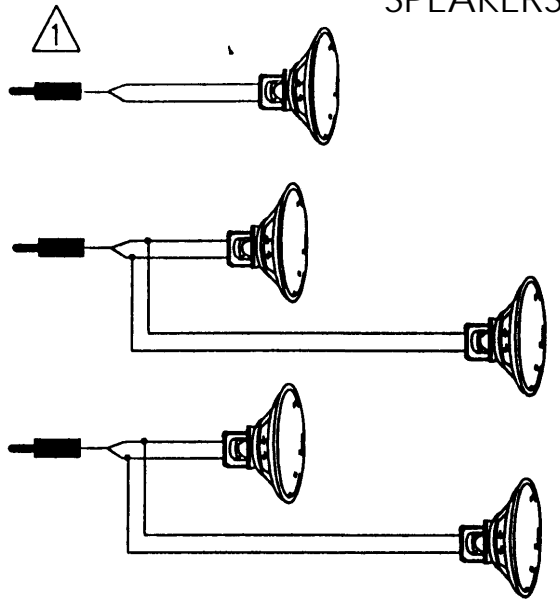

PARTNER PLUS / II

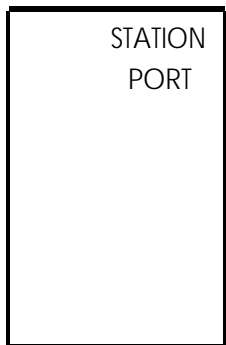

PARTNER PAGEPAC

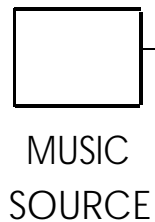
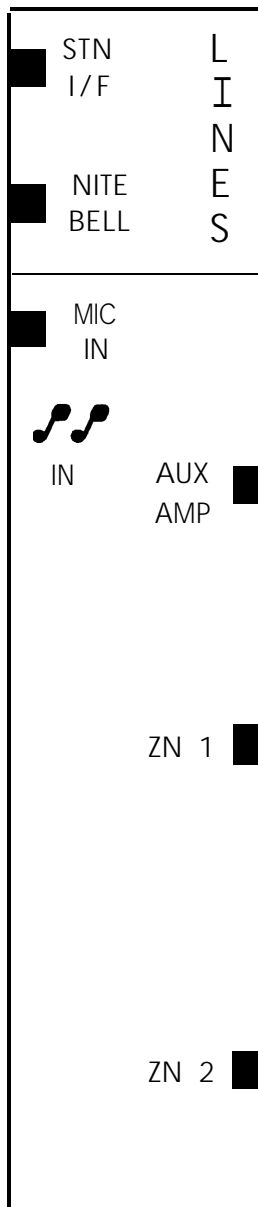

PARTNER PLUS / II

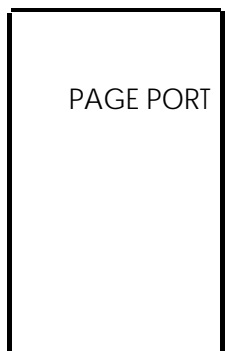

103 BLOCK

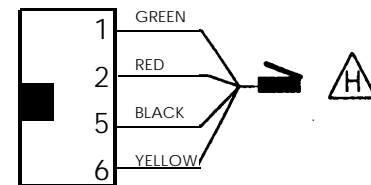

ZN 1

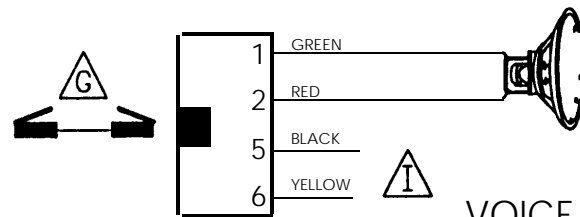

VOICE COIL SPEAKERS

103 BLOCK

ZN 2

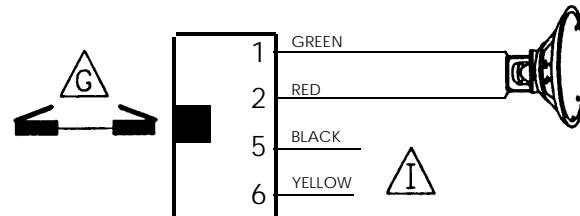

103 BLOCK



PAGEPAC 20
POWERMATE

MUSIC SOURCE

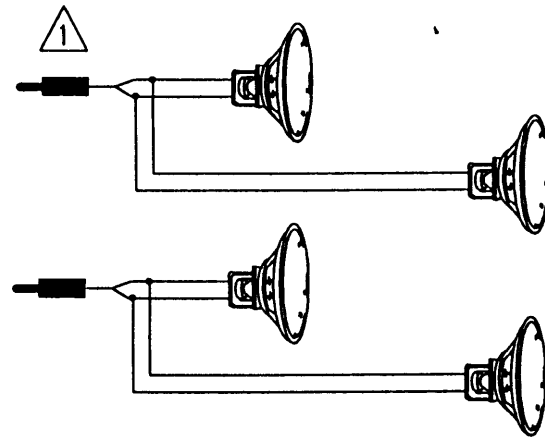
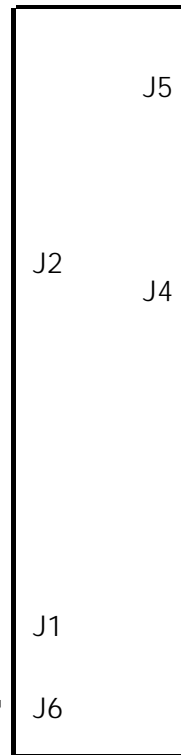
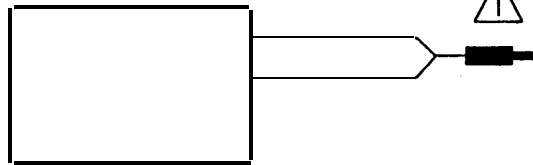

VOICE COIL
SPEAKERS

70 VOLT
SPEAKERS

PARTNER
PLUS / II

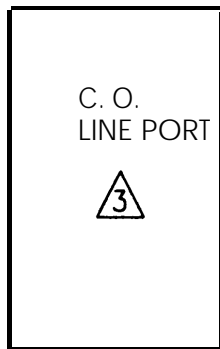

TRUNK
ADAPTER

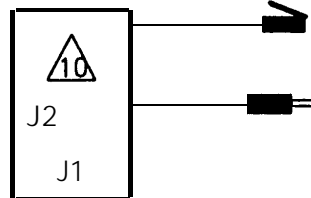

PAGEPAC 20
POWERMATE

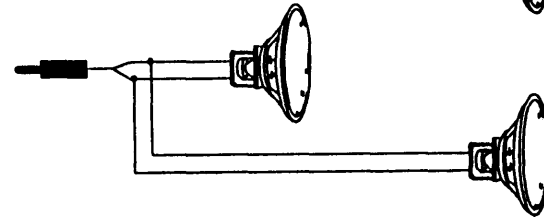
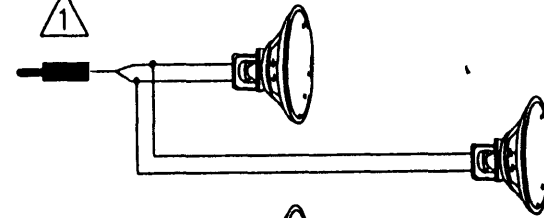
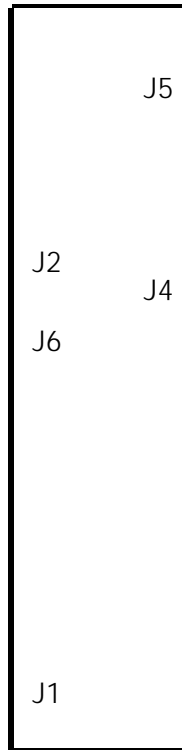

VOICE COIL
SPEAKERS

70 VOLT
SPEAKERS

PARTNER
PLUS / II

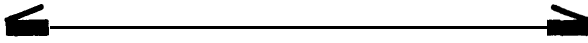
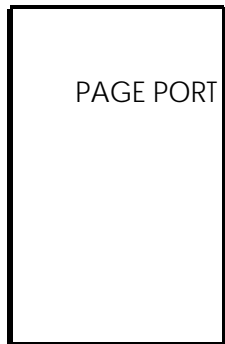

PAGEPAC 20
POWERMATE

PAGEPAC 20
TALKMATE

VOICE COIL
SPEAKERS

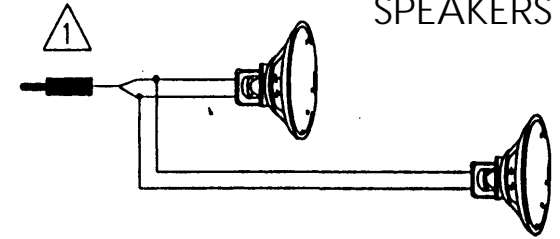
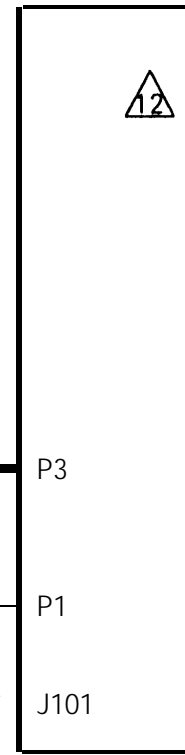
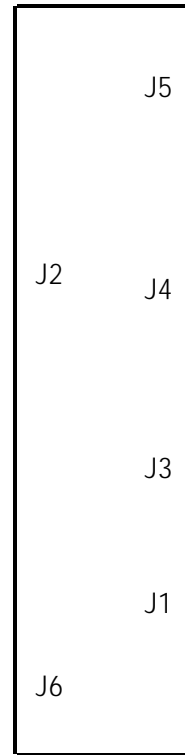
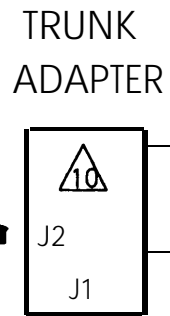
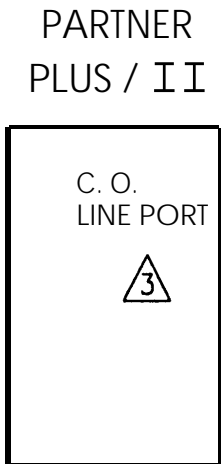
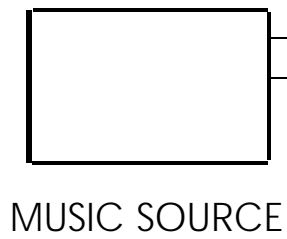

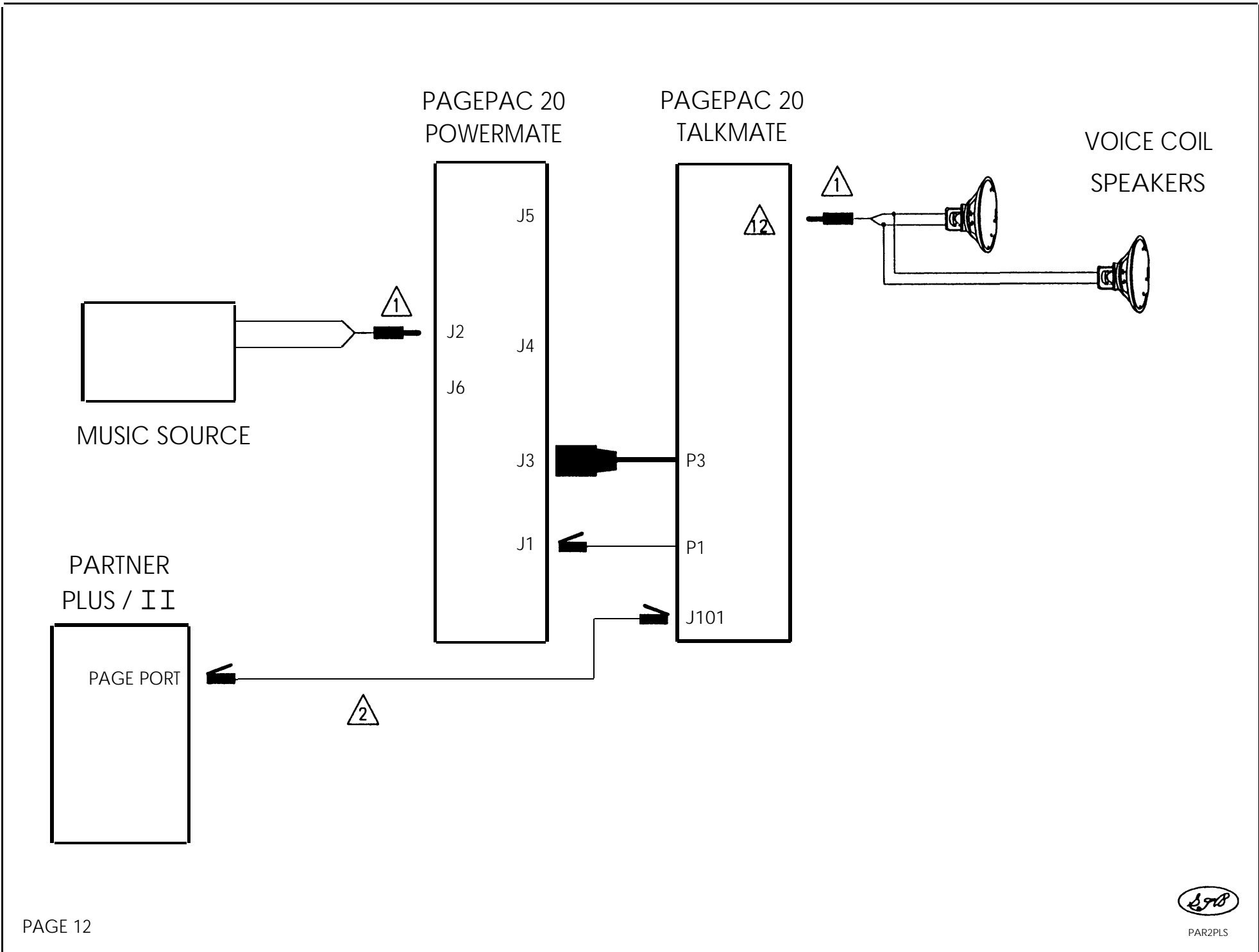

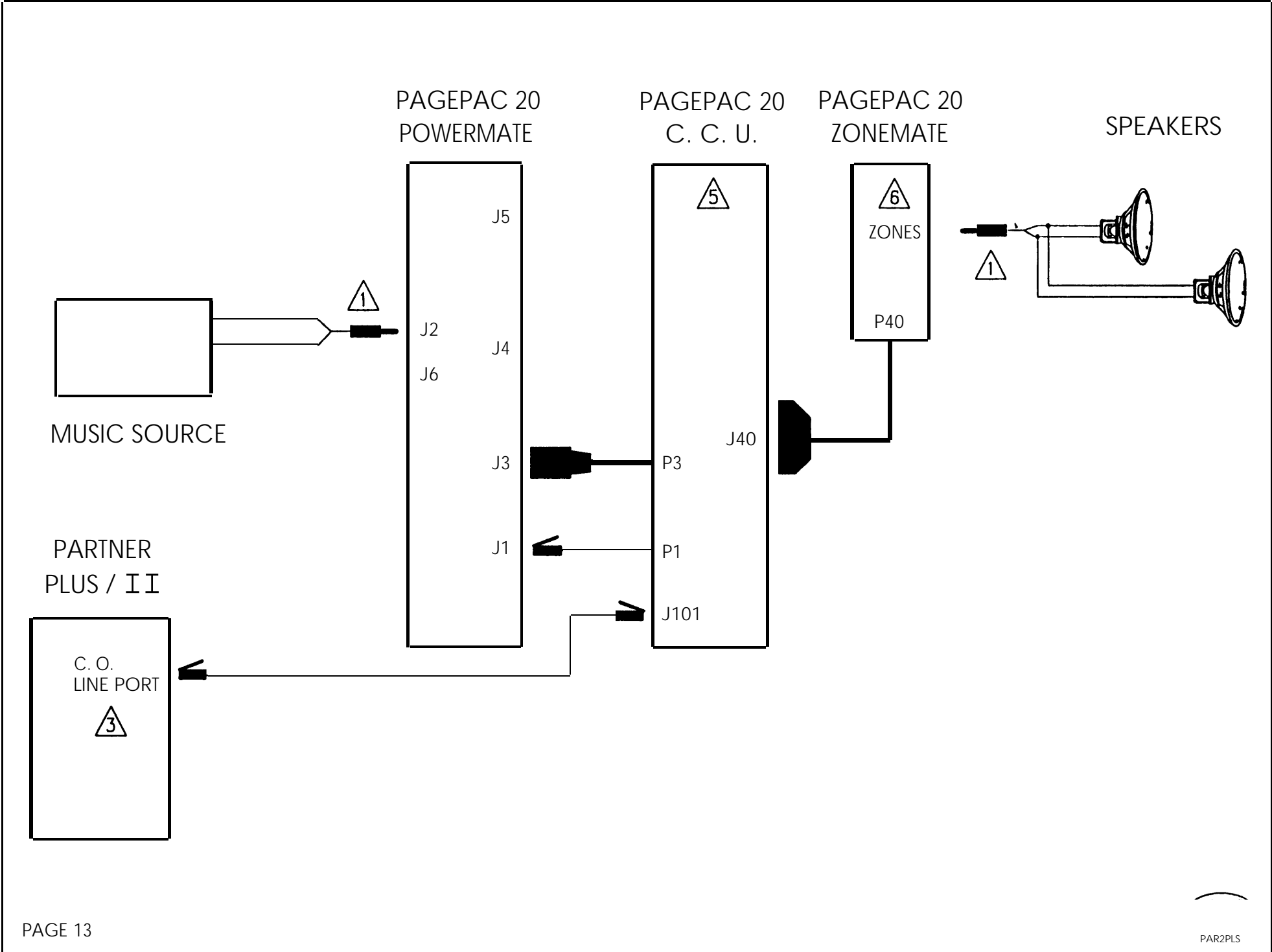

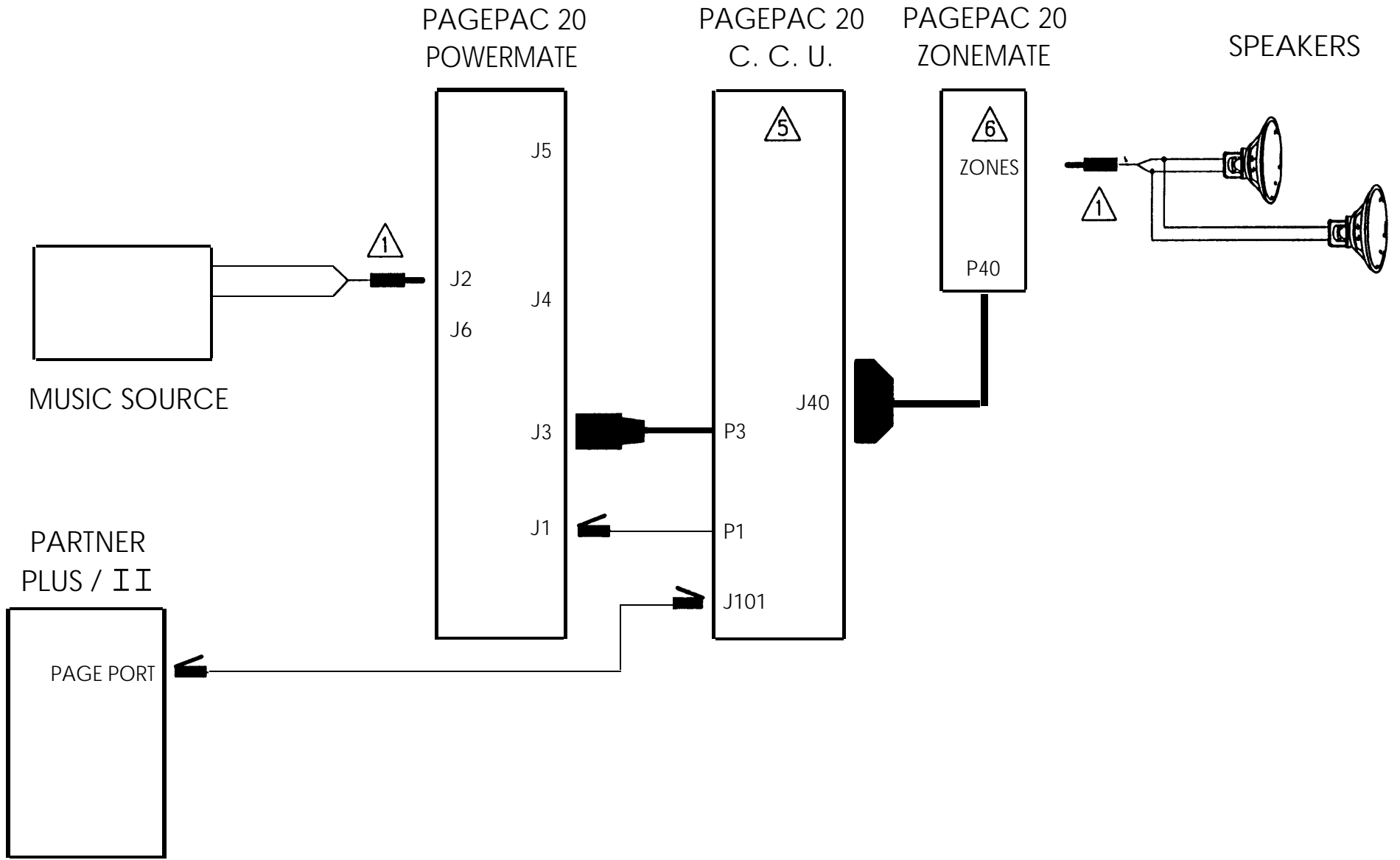

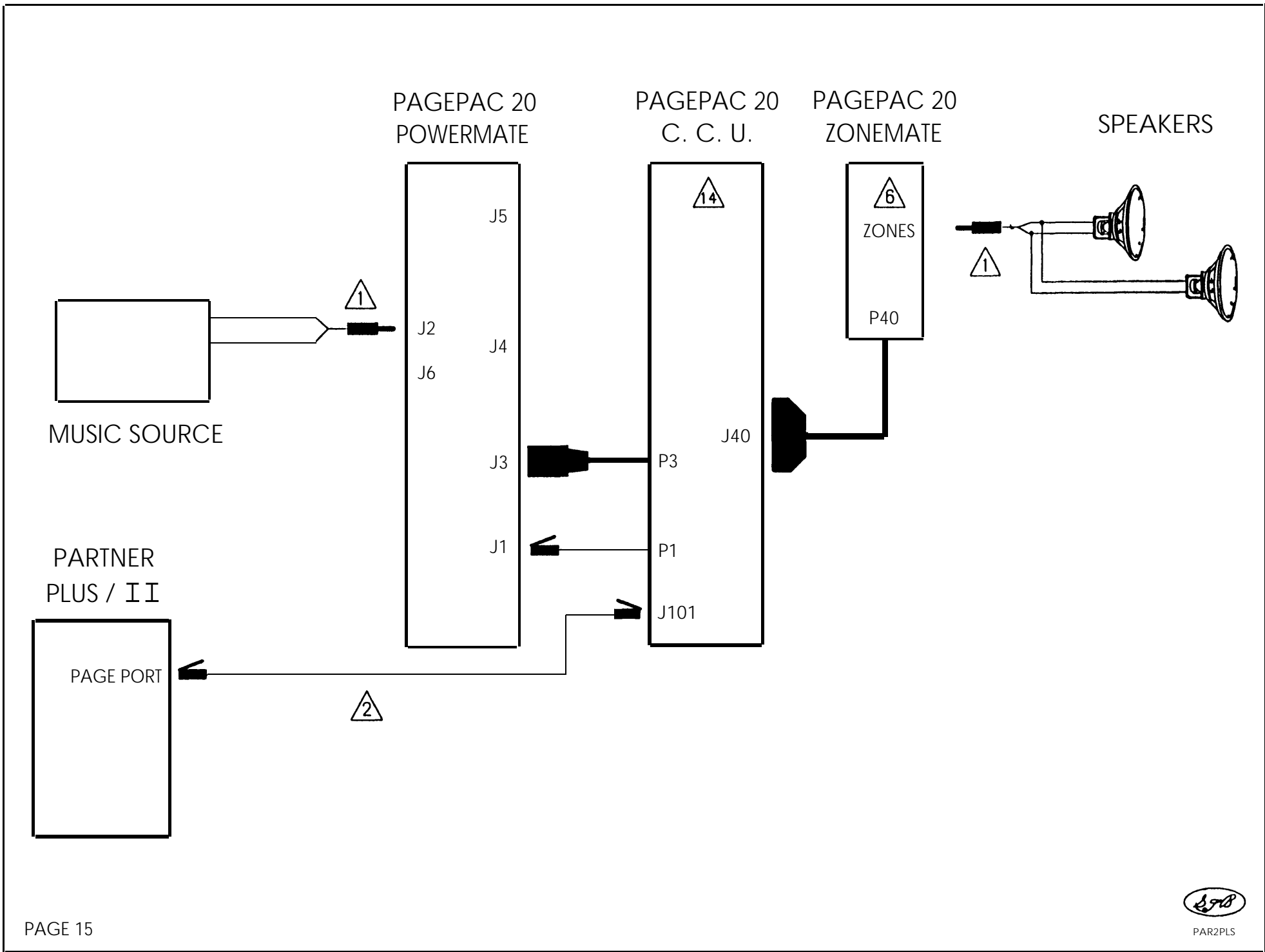

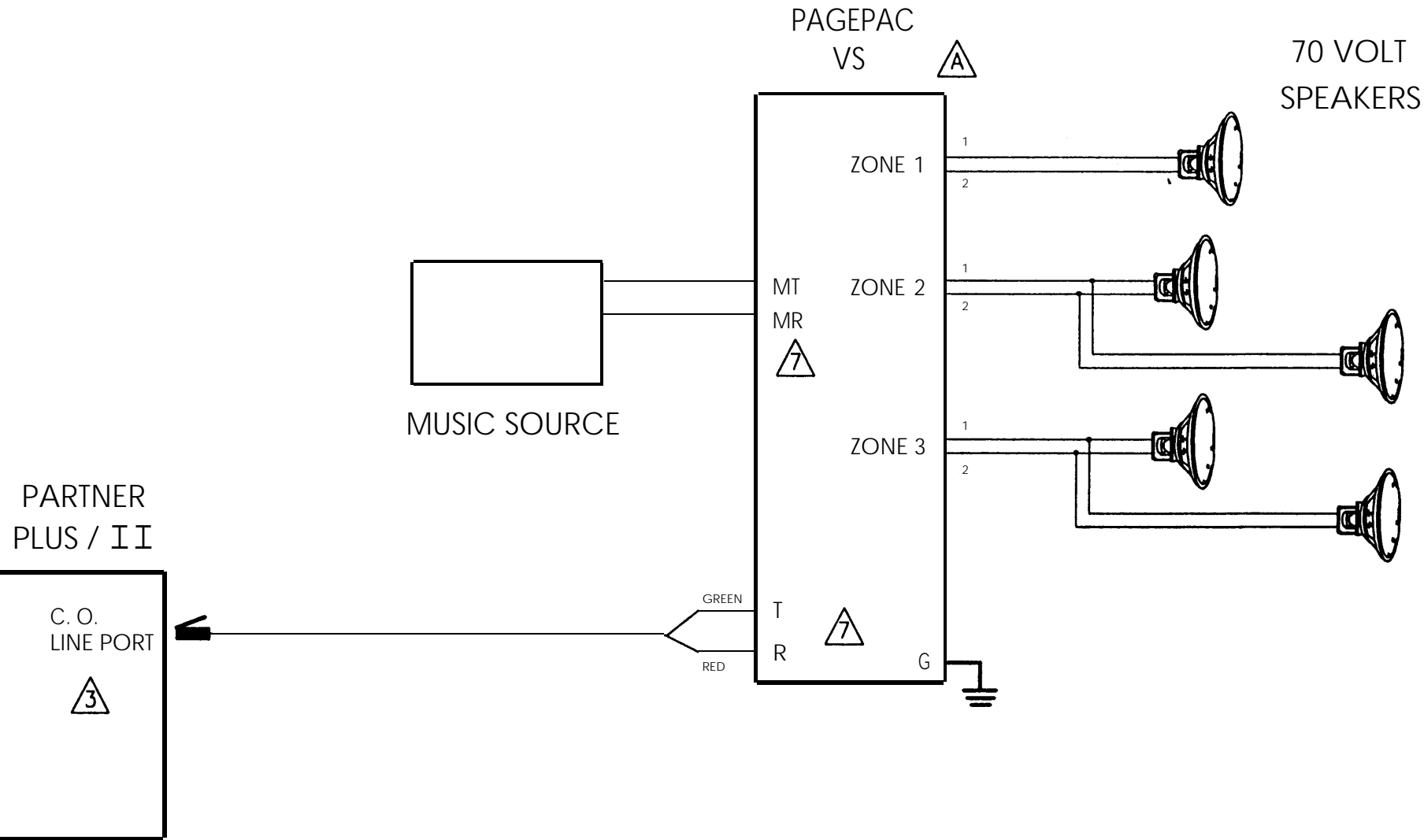

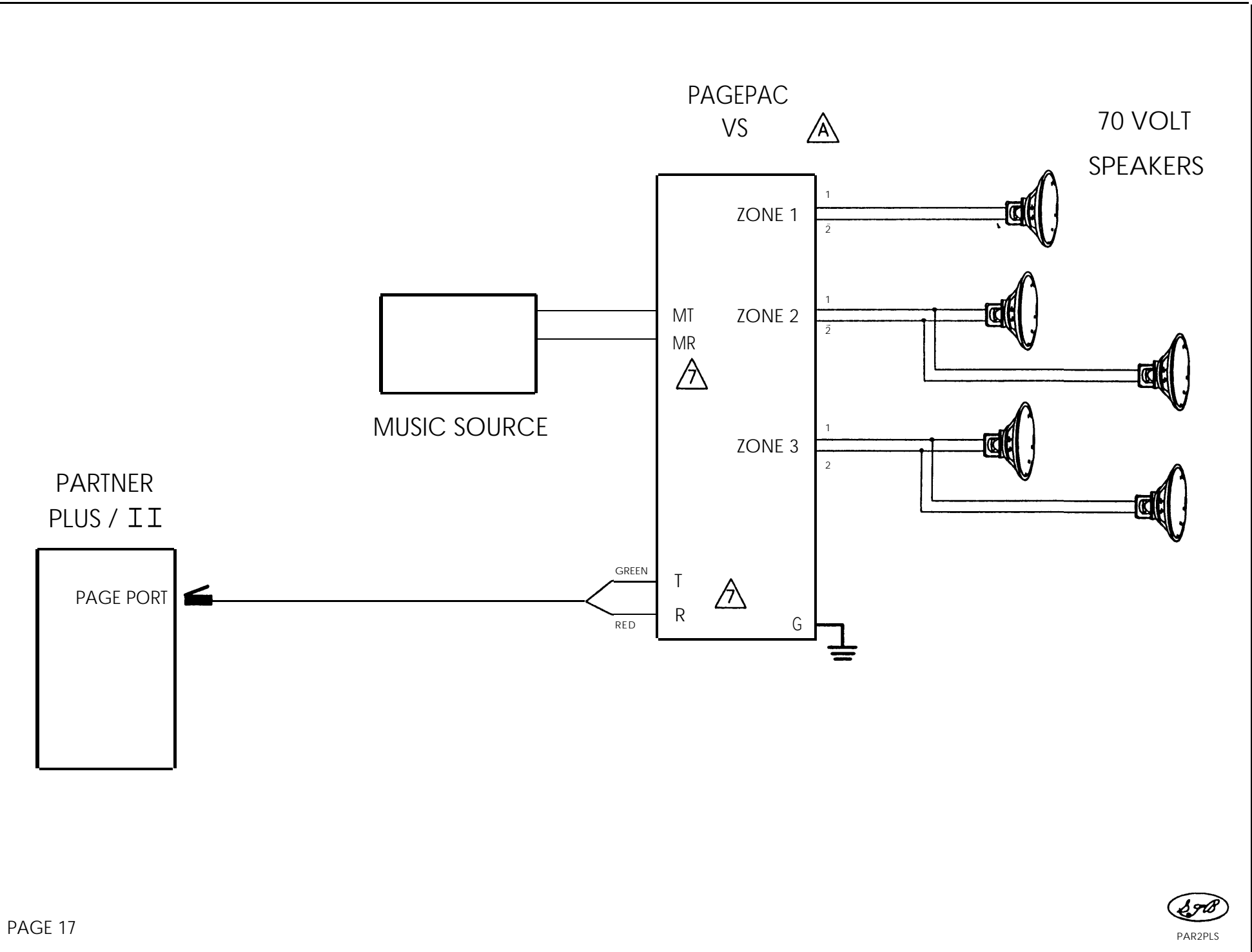

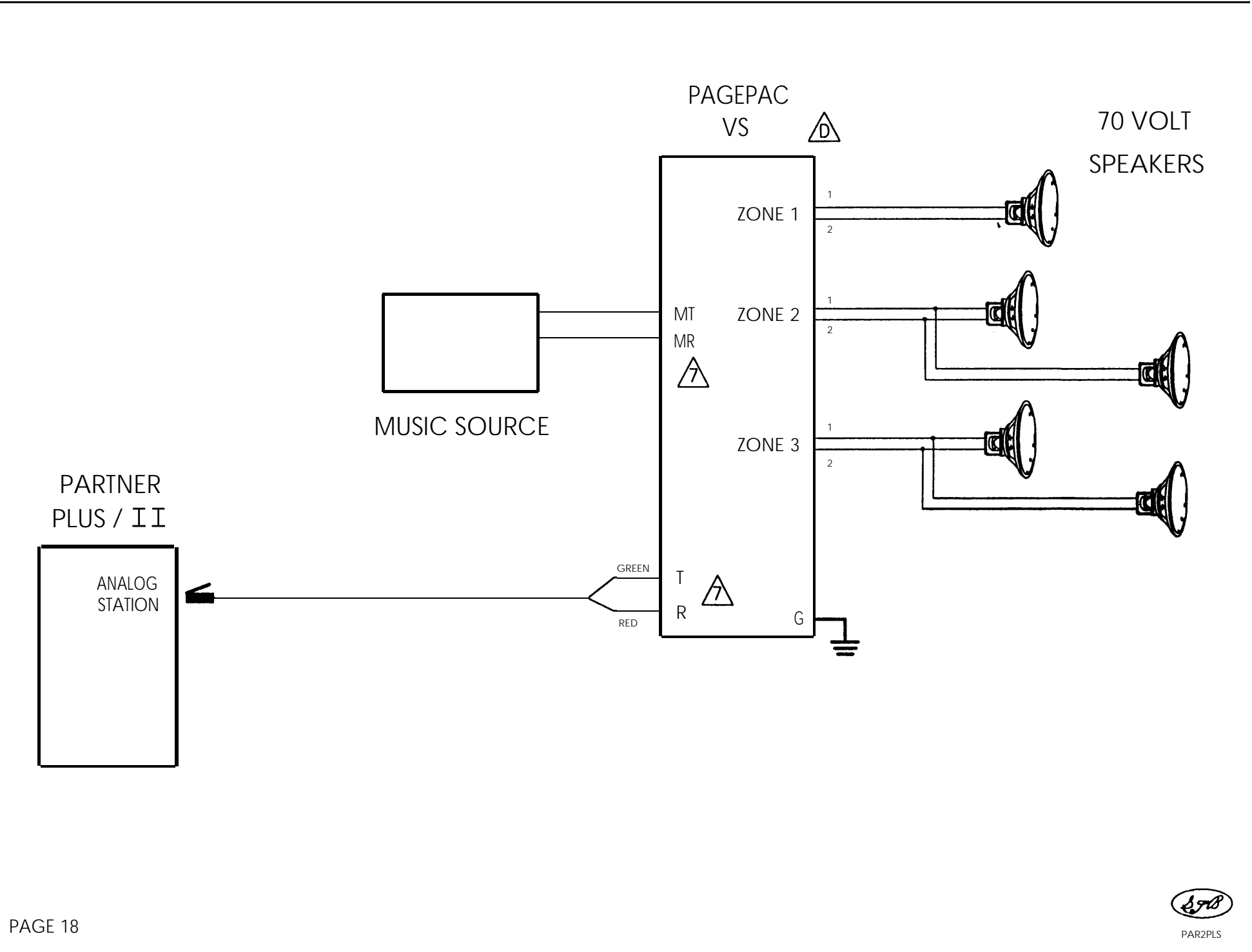





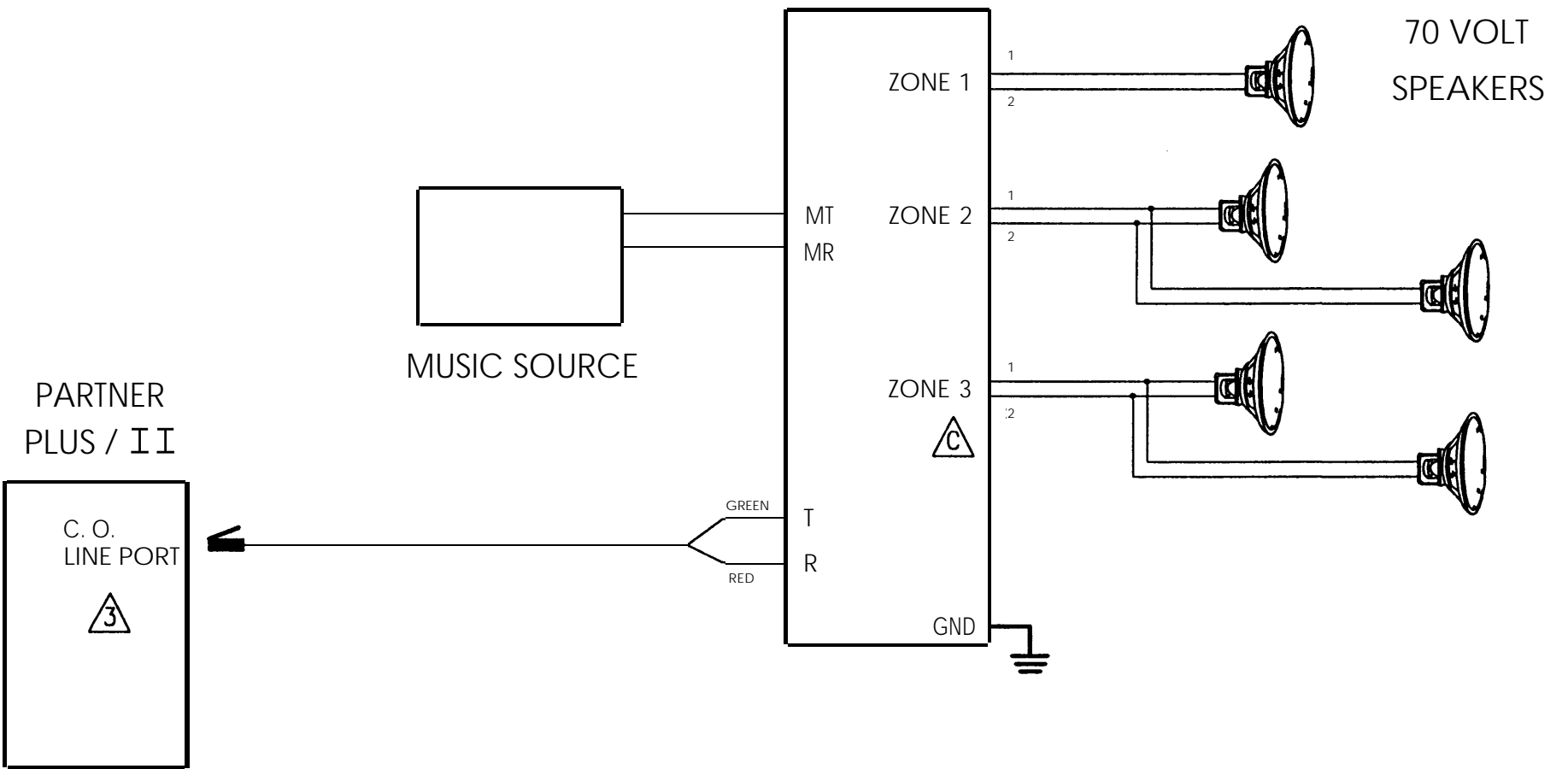

PAGEPAC
50, 100 & 200 

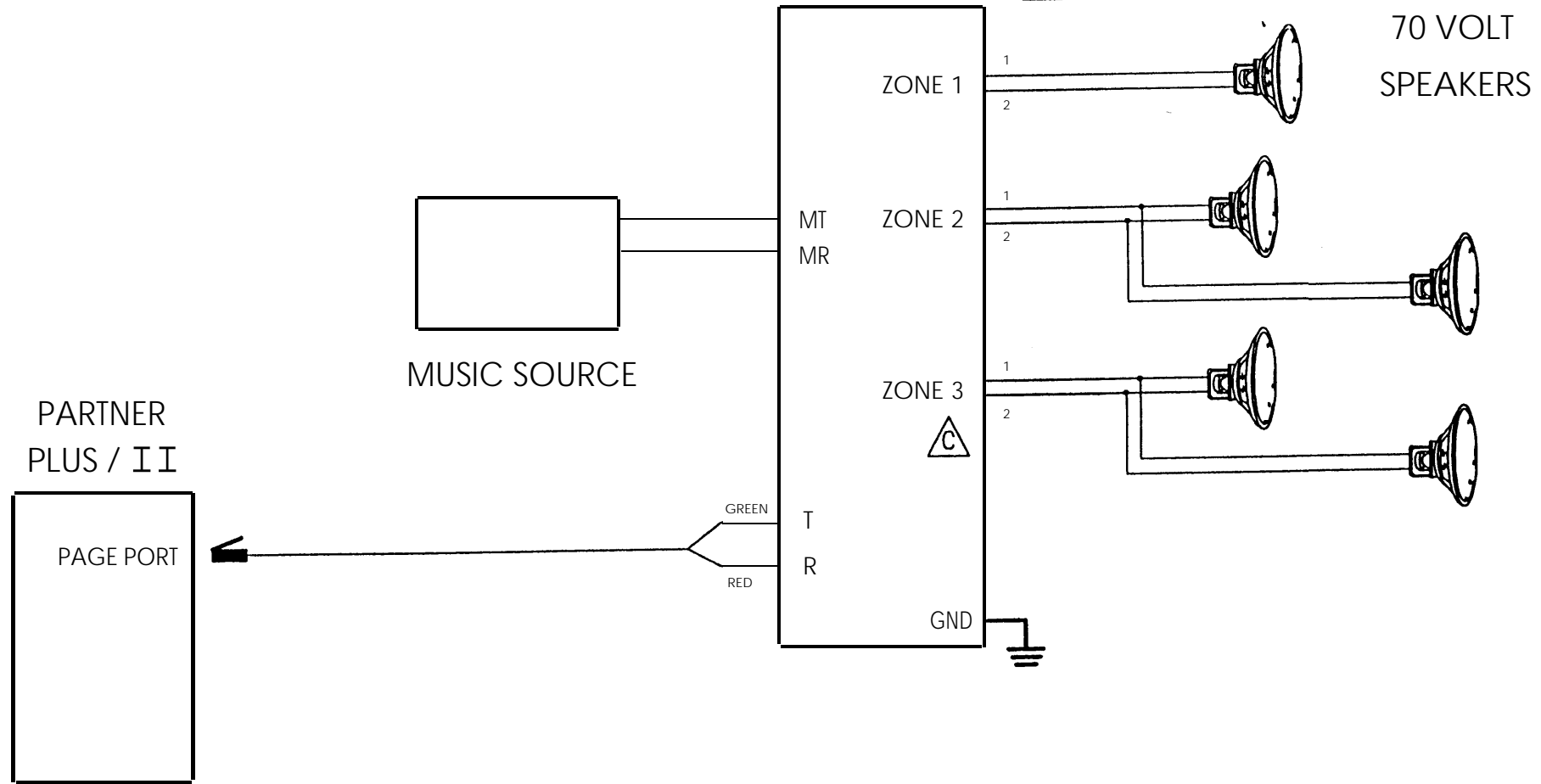

PAGEPAC
50, 100 & 200 



PAGEPAC
50, 100 & 200 

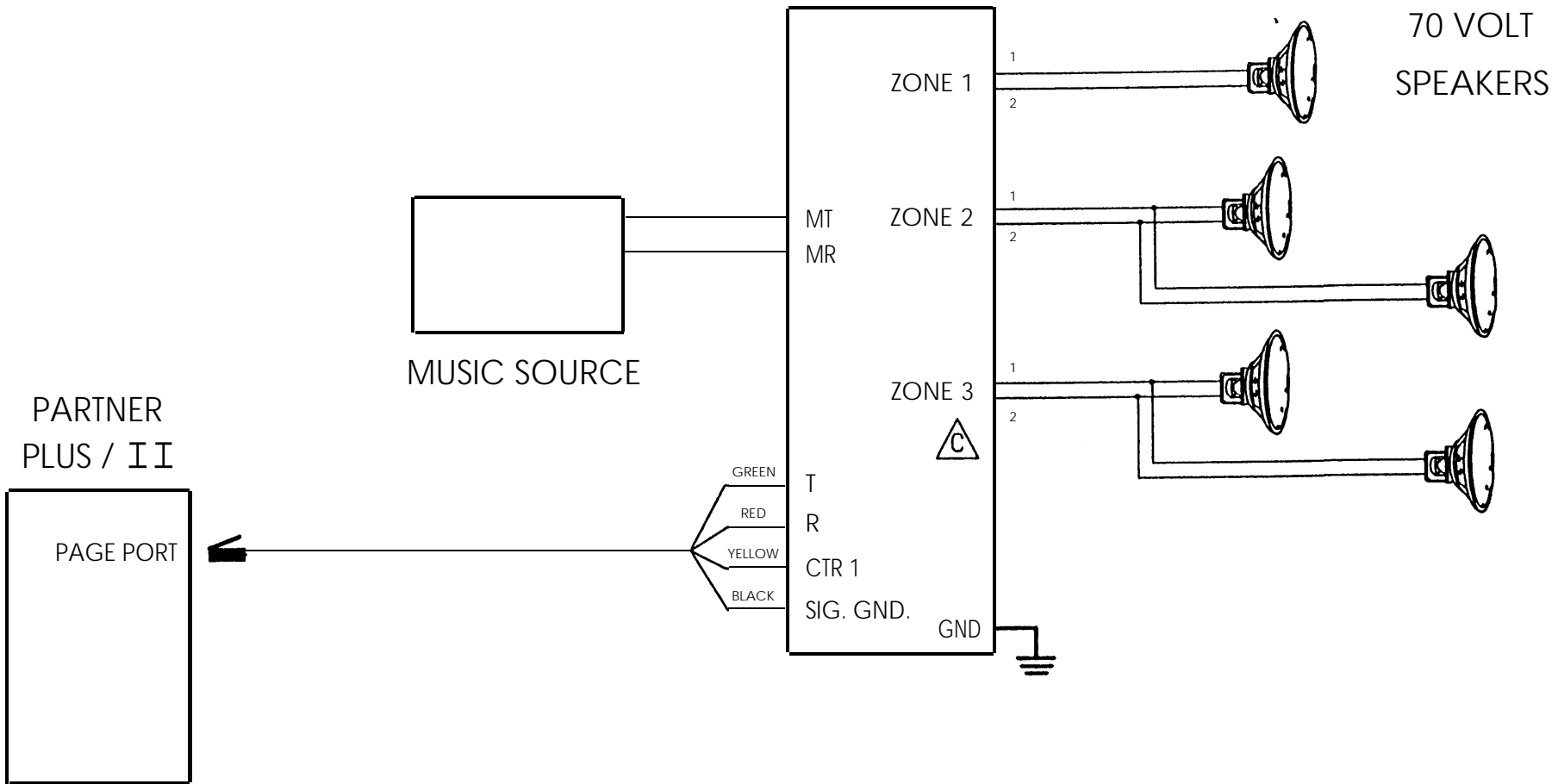

PAGEPAC
50, 100 & 200 

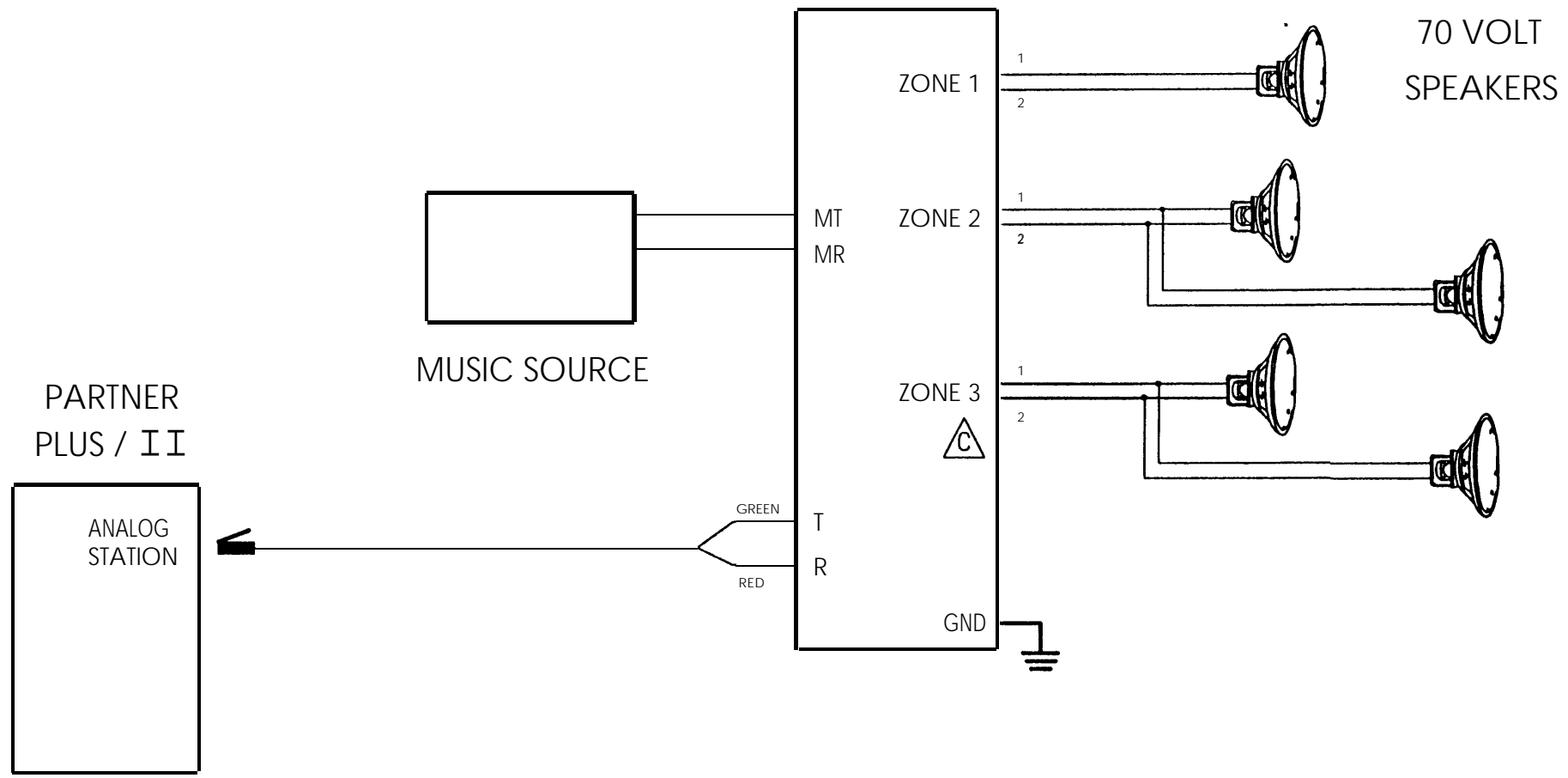

AMPLICENTER
50, 100 & 200

70 VOLT
SPEAKERS

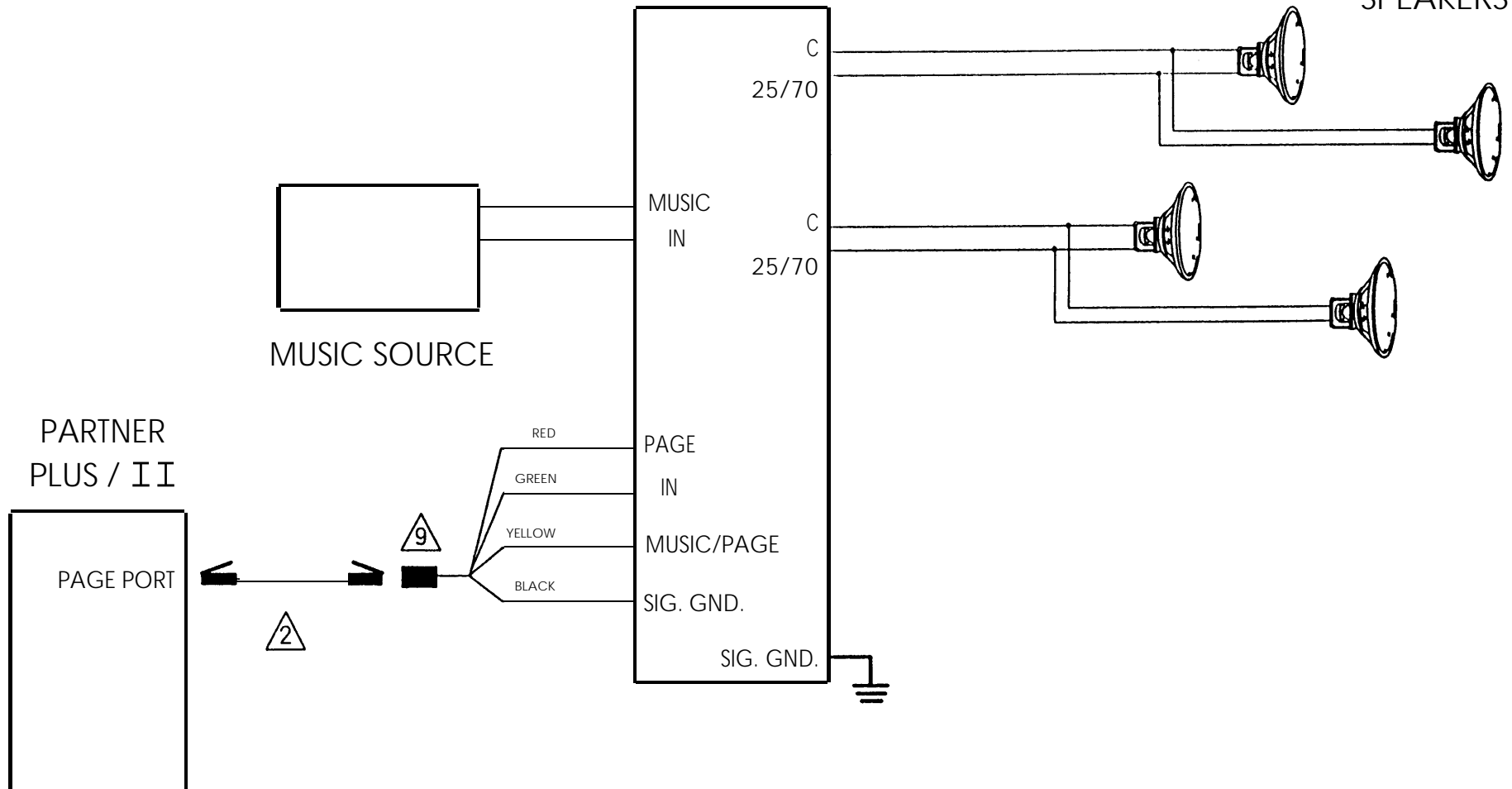

AMPLICENTER
50, 100 & 200

70 VOLT
SPEAKERS

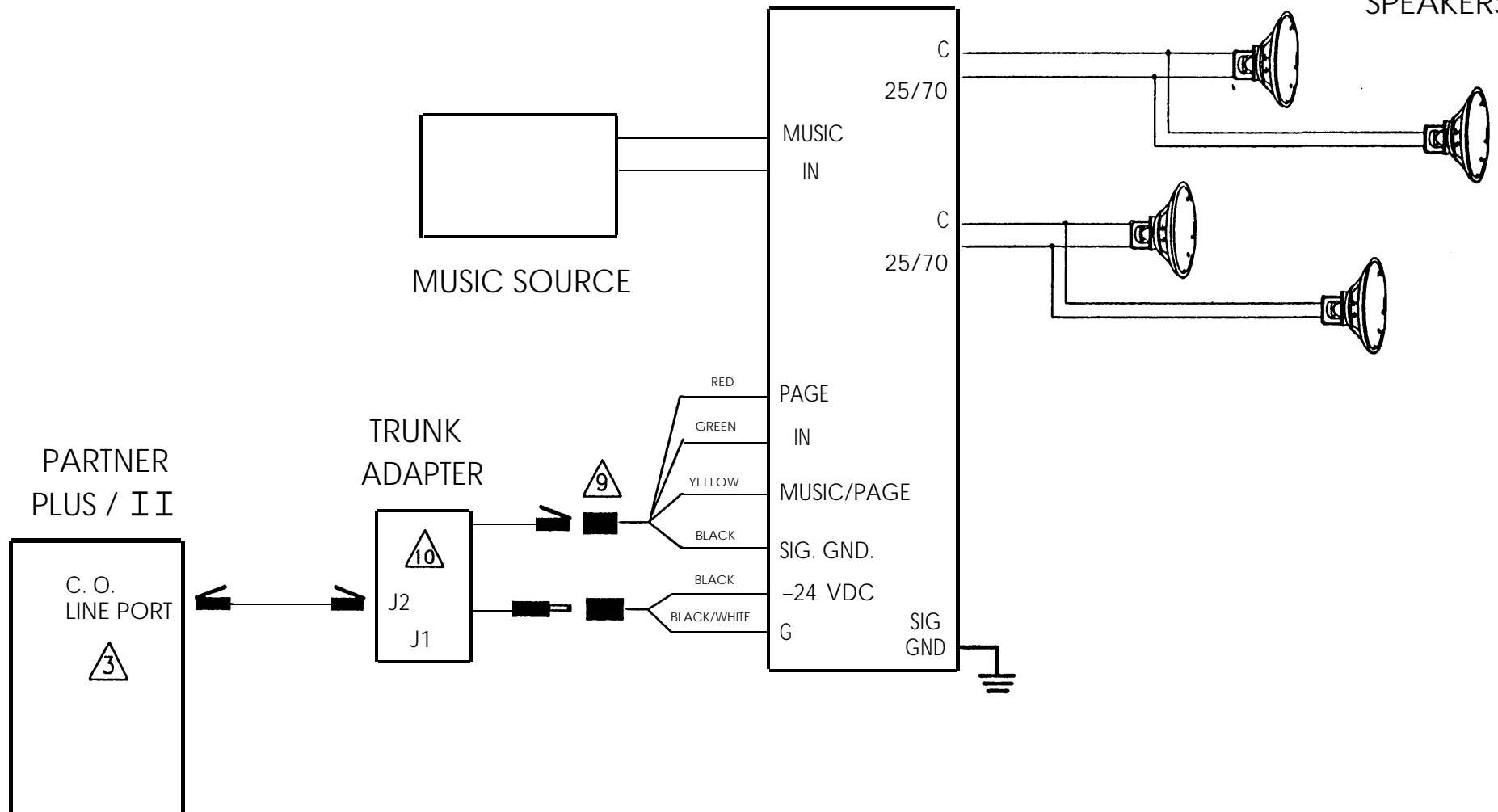

D20, D100, D300
AMPLICENTER

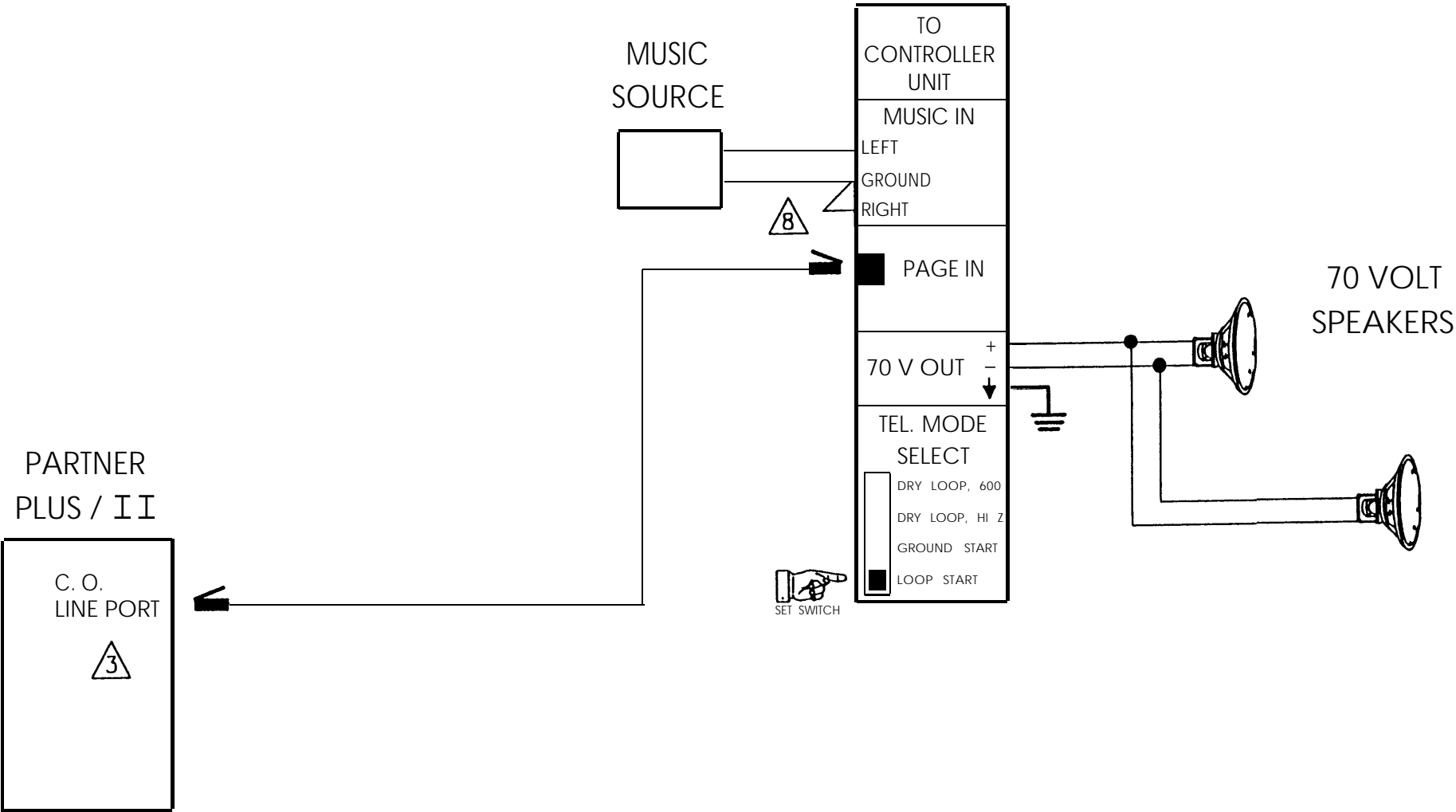

D20, D100, D300 AMPLICENTER

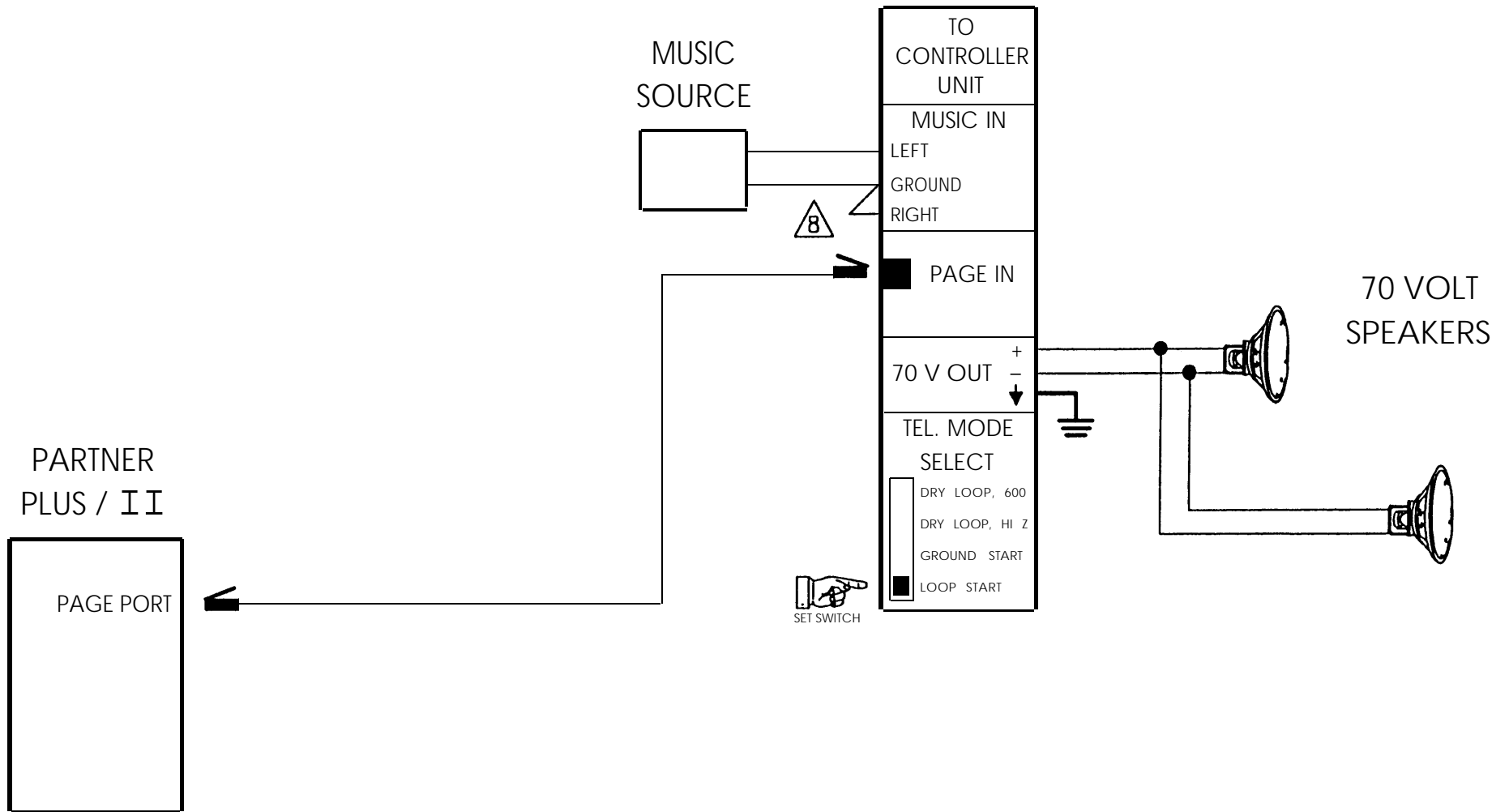

D20, D100, D300 AMPLICENTER

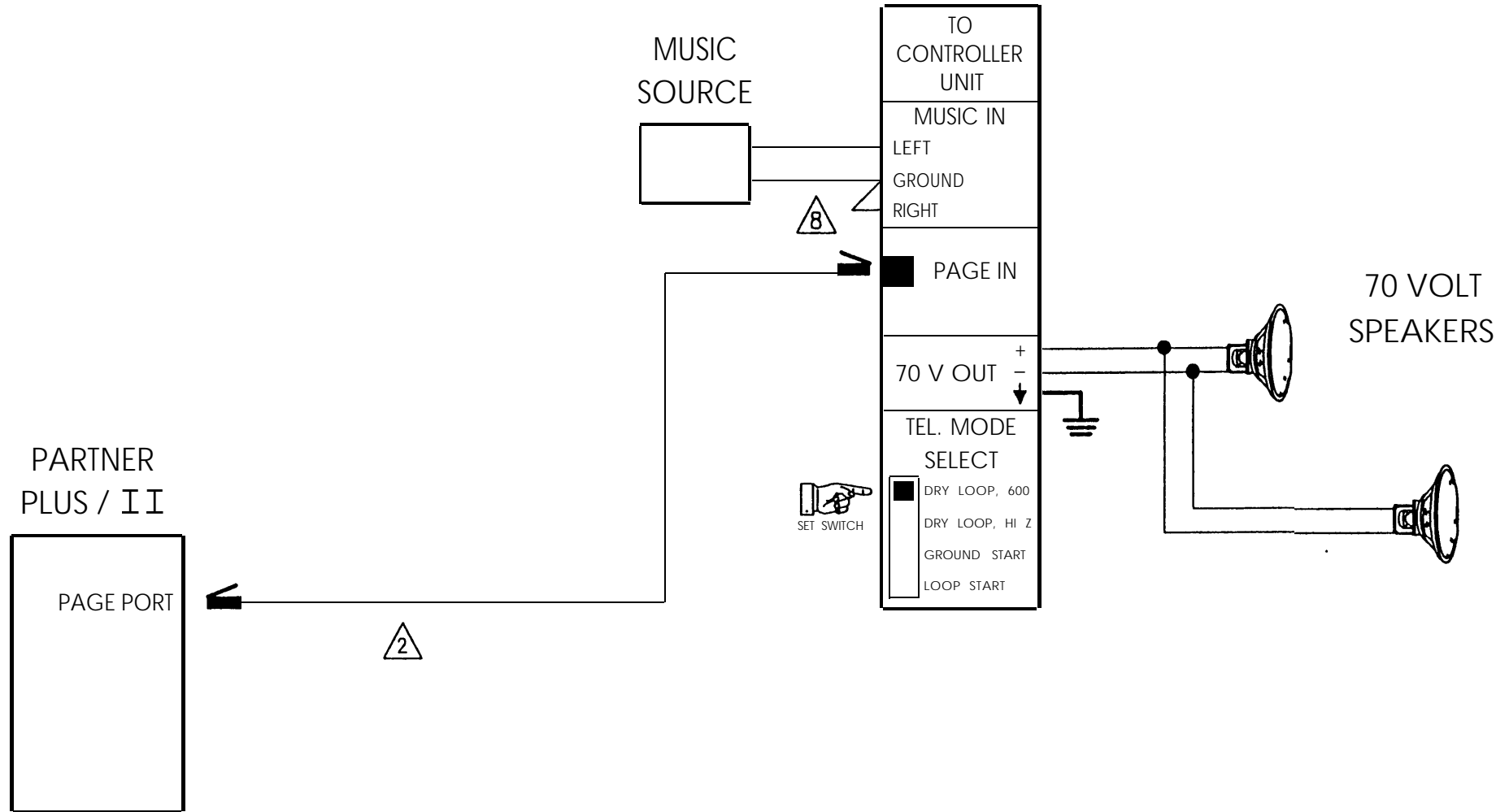

PARTNER PLUS / II

PAGE PORT

70 VOLT SPEAKERS

D20, D100, D300 AMPLICENTER

PAGEPAC PLUS CONTROLLER

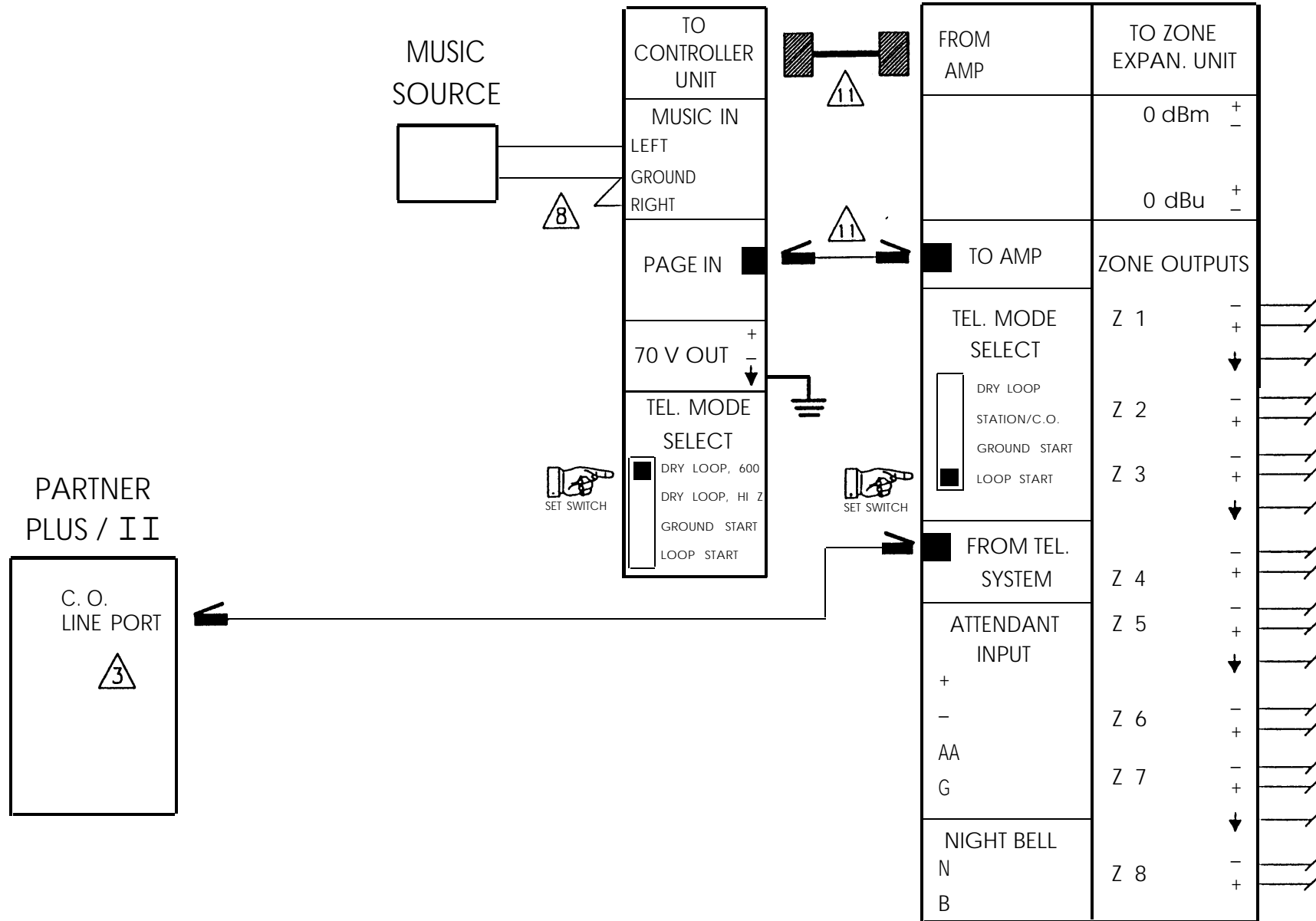

D20, D100, D300 AMPLICENTER

PAGEPAC PLUS CONTROLLER

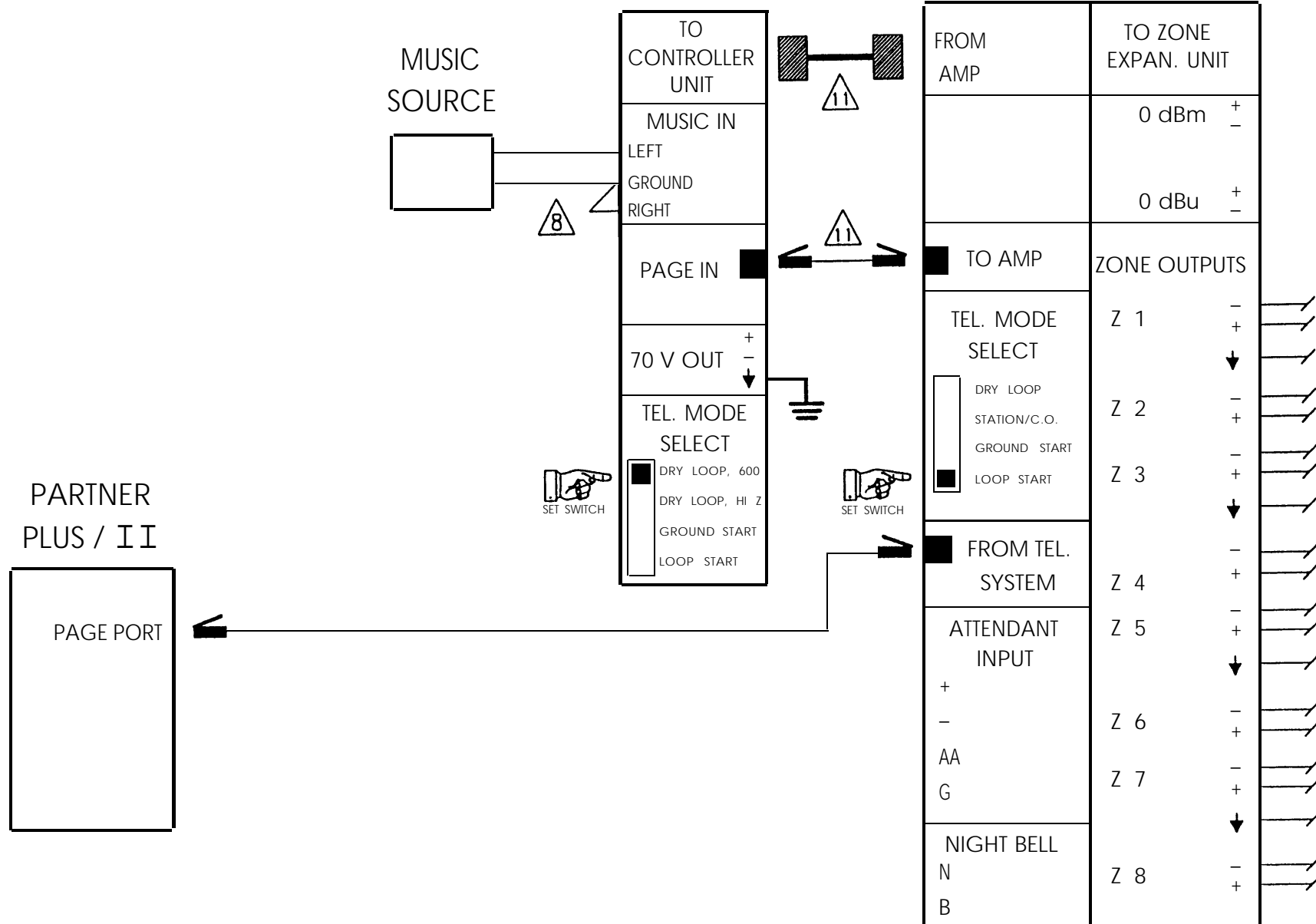

D20, D100, D300 AMPLICENTER

PAGEPAC PLUS CONTROLLER

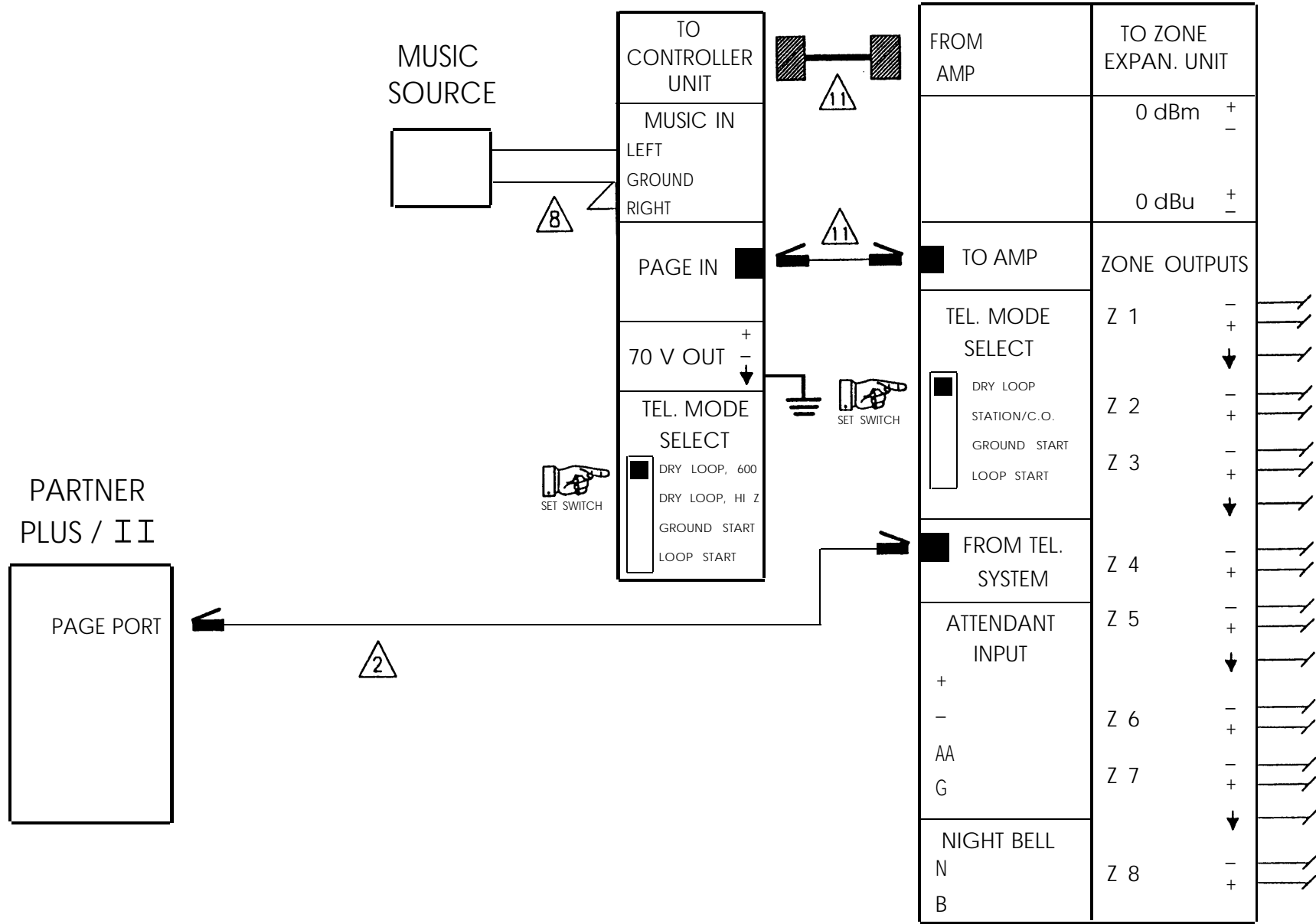

D20, D100, D300 AMPLICENTER

PAGEPAC PLUS CONTROLLER

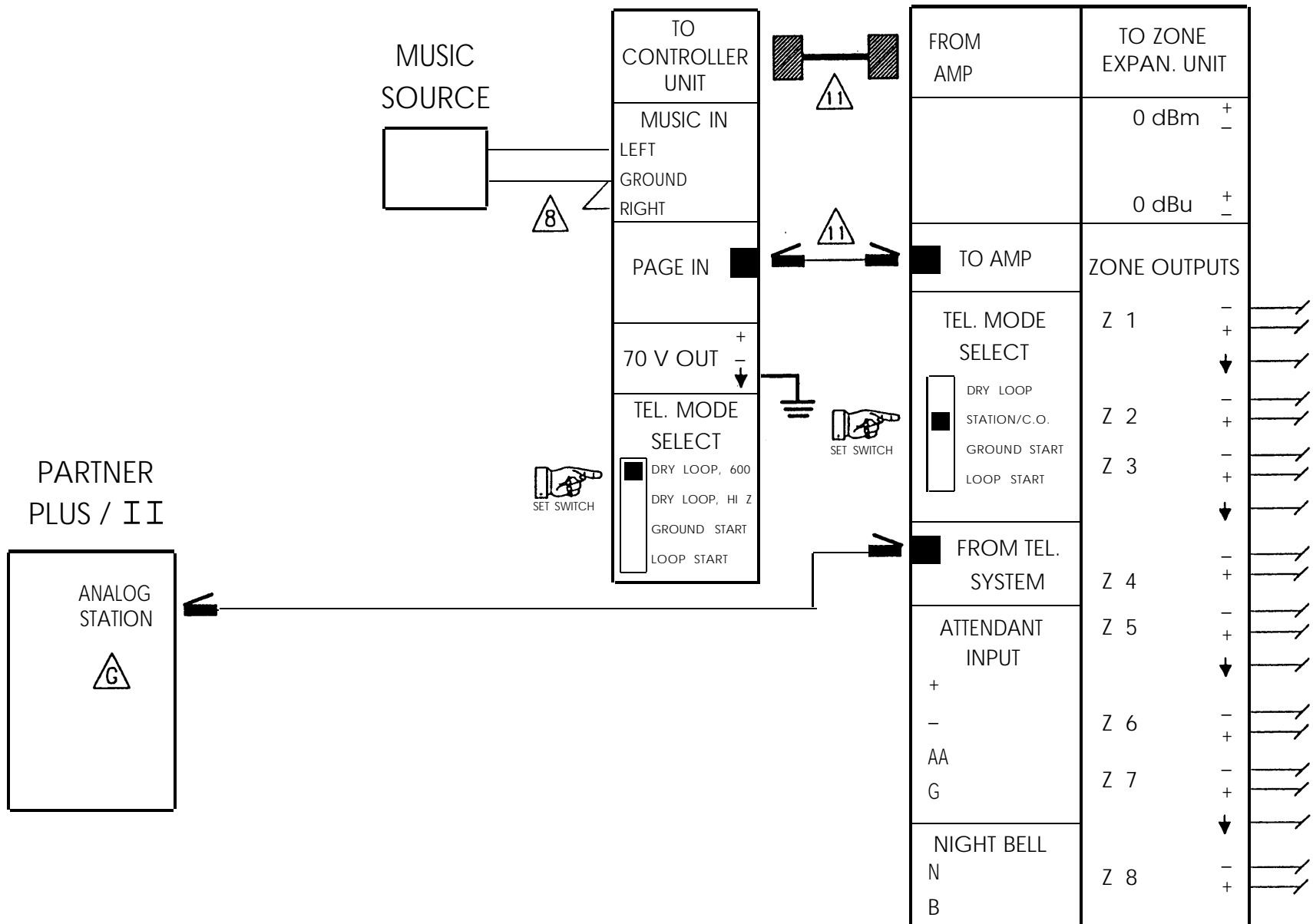











NOTES:

- 1 RCA PLUGS.
- 2 A FOUR-CONDUCTOR MODULAR CORD MUST BE USED.
- 3 LINE PORT IS DEDICATED TO PAGING ONLY.
- 4 THESE CONNECTIONS ALLOW BOTH C.O. LINE PORTS TO ACCESS PAGING AND/OR OUTSIDE LINES.
- 5 PAGEPAC 20 COMMON CONTROL UNIT (C.C.U.) SET TO THE LOOP START (LS) POSITION.
- 6 CAN BE EITHER A ZONEMATE 9 OR A ZONEMATE 39. THE ZONEMATE 9 CAN BE CONFIGURED FOR 9 "VOICE COIL" ZONES OR 6 "VIOCE COIL" ZONES AND 3 "70 VOLT" ZONES. ALL 39 ZONES OF THE ZONEMATE 39 ARE "VOICE COIL" OUTPUTS ONLY. TALKBACK CAN ONLY BE PROGRAMMED INTO "VOICE COIL" ZONES ON THESE SYSTEMS.
- 7 THE "MUSIC IN" PORT (MT/MR) IS FOUND IN "TB1" OF THE "UNIVERSAL INTERFACE CARD" (U.I.C.). THE "TIP/RING" PORT (T/R) IS FOUND ON "TB2" OF THE U.I.C.
- 8 STRAP TOGETHER.
- 9 ADAPTER CABLE SET P/N 22050-902 SUPPLIED WITH EACH AMPLICENTER.
- 10 LOOP START TRUNK ADAPTER.
- 11 USE ONLY THE CABLES PROVIDED WITH THE EQUIPMENT.
- 12 JACK LABELLED "TALKBACK VOICE COIL OUT".
- 13 THESE CONNECTIONS ALLOW ONE C.O. LINE PORT TO ACCESS PAGING AND/OR OUTSIDE LINES.
- 14 PAGEPAC 20 COMMON CONTROL UNIT (C.C.U.) SET TO THE DRY LOOP (DL) POSITION.



NOTES:

-  THE PAGEPAC VS COMES EQUIPPED WITH A "UNIVERSAL INTERFACE CARD" (U.I.C.). THE PAGEPAC VS WILL ONLY SUPPORT 3 ZONES, WITH AN ALL-CALL, OF PAGING. THE U.I.C. MUST BE OPTIONED FOR THE LOOP START ACCESS MODE.
-  THE PAGEPAC 50, 100 AND 200 WATT UNITS ALL COME EQUIPPED WITH A "C" APPLIQUE CARD AND A MASTER ZONE CARD. THE "C" APPLIQUE CARD MUST BE OPTIONED FOR THE LOOP START ACCESS MODE. WITH THESE TWO CARDS, THE PAGEPACS WILL SUPPORT 4 ZONES, WITH AN ALL-CALL, OF PAGING. THE ADDITION OF 5 AUXILIARY ZONE CARDS WILL BRING THE PAGEPACS UP TO THEIR MAXIMUM OF 24 ZONES.
-  ONLY CONNECTIONS FOR THE FIRST 3 ZONES ARE SHOWN HERE.
-  THE PAGEPAC VS MUST BE OPTIONED FOR THE STATION ACCESS MODE.
-  THE "C" APPLIQUE CARD MUST BE OPTIONED FOR THE DRY LOOP ACCESS MODE.
-  THE "C" APPLIQUE CARD MUST BE OPTIONED FOR THE STATION ACCESS MODE.
-  8 CONDUCTOR MODULAR CORD.
-  FOUR WIRE CONNECTION TO OPERATE A REMOTE OR AUXILIARY AMPLIFIER.
-  THESE CONNECTIONS (5 & 6) ARE ONLY USED WHEN ZONES 1 OR 2 ARE CONFIGURED FOR DOOR SPEAKER OR REMOTE AMPLIFIER USE.
-  PAGE PORT ACCESS IS PREFERRED. PARTNER PAGEPAC WILL ALSO ACCEPT DIGITAL STATION PORTS FOR ACCESS AND AUTOMATICALLY RECOGNIZES WHICH TYPE PORT IS CONNECTED.