

Panasonic

2.4GHz Digital Cordless Phone

Model No. **KX-TG2205W**

Pulse-or-tone dialing capability

Operating Instructions



Preparation

Basic Operation

Advanced Operation

Useful Information

PLEASE READ BEFORE USE AND SAVE.

Charge the battery for about 15 hours before initial use.

Panasonic World Wide Web address: <http://www.panasonic.com>
for customers in the USA or Puerto Rico

Before Initial Use

Please read IMPORTANT SAFETY INSTRUCTIONS on page 26 before use. Read and understand all instructions.

Thank you for purchasing your new Panasonic cordless telephone.

Attach your purchase receipt here.

For your future reference

Serial No. _____
(found on the bottom of the unit)

Date of purchase _____

Name and address of dealer _____

Accessories (included) For extra orders, call 1-800-332-5368.

- AC Adaptor (p. 7)
Order No. KX-TCA1-G

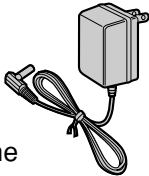

one

- Telephone Line Cord
(p. 7)
Order No. PQJA10075Z

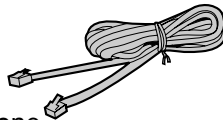

one

- Battery (p. 8, 22)
Order No.
PQPP511SVC
(P-P511)

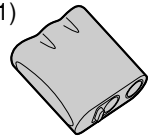

one

- Handset Cover
(p. 8, 22)
Order No.
PQKK10127Y2



one

- Wall Mounting Adaptor
(p. 20)
Order No.
PQKL10035Z2

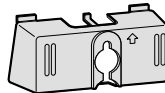

one

- Belt Clip (p. 19)
Order No.
PQKE10341Z2

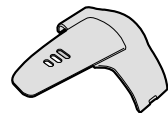

one

For Best Performance

Battery Charge

A rechargeable Ni-Cd battery powers the handset. Charge the battery for about **15 hours** before initial use (p. 8).

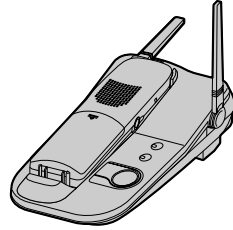

Base Unit Location/Noise

Calls are transmitted between the base unit and the handset using wireless radio waves. **For maximum distance and noise-free operation**, the recommended base unit location is:

Away from electrical appliances such as a TV, personal computer or another cordless phone.

In a HIGH and CENTRAL location with no obstructions such as walls.

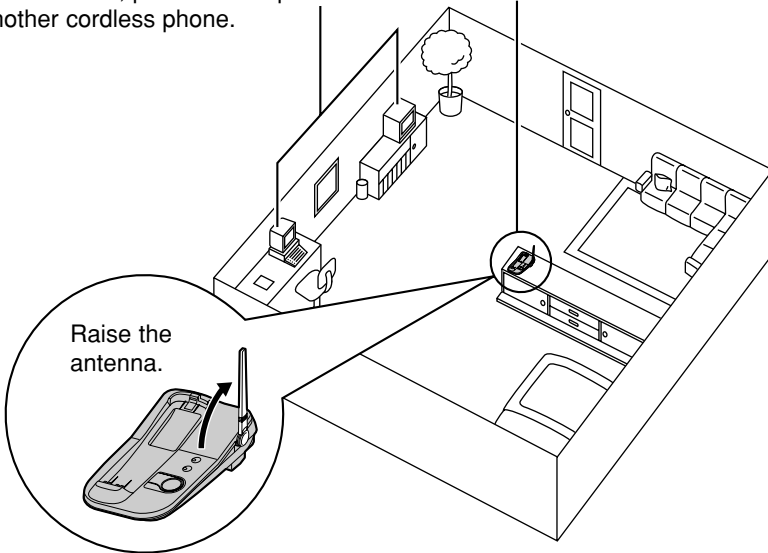

Note:

While using the handset:

- If you are near a microwave oven which is being used, noise may be heard from the receiver or the speaker. Move away from the microwave oven and closer to the base unit.
- If more than one cordless phone is being used and your handset is near another cordless phone's base unit, noise may be heard. Move away from the other cordless phone's base unit and closer to your base unit.

Contents

Preparation

Location of Controls	5
Settings	7
Connections	7
Installing the Battery in the Handset	8
Battery Charge	8
Dialing Mode	10
Ringer Volume	11
Ringer Pattern	11

Basic Operation

Making Calls	12
Answering Calls	14

Advanced Operation

Speed Dialer	15
Storing Phone Numbers	15
Dialing a Stored Number	15
Special Features	16
Automatic Security Code Setting	16
Handset Locator	16
Temporary Tone Dialing (For Rotary or Pulse Service Users)	17
Muting Your Conversation	17
For Call Waiting Service Users	17
How to Use the PAUSE Button (For Analog PBX Line/Long Distance Service Users)	17
FLASH Button	18

Useful Information

Belt Clip	19
Optional Headset	19
Wall Mounting	20
Battery Replacement	22
Adding Another Phone	23
Troubleshooting	24
Important Safety Instructions	26
FCC and Other Information	28
Index	31

Location of Controls



Handset

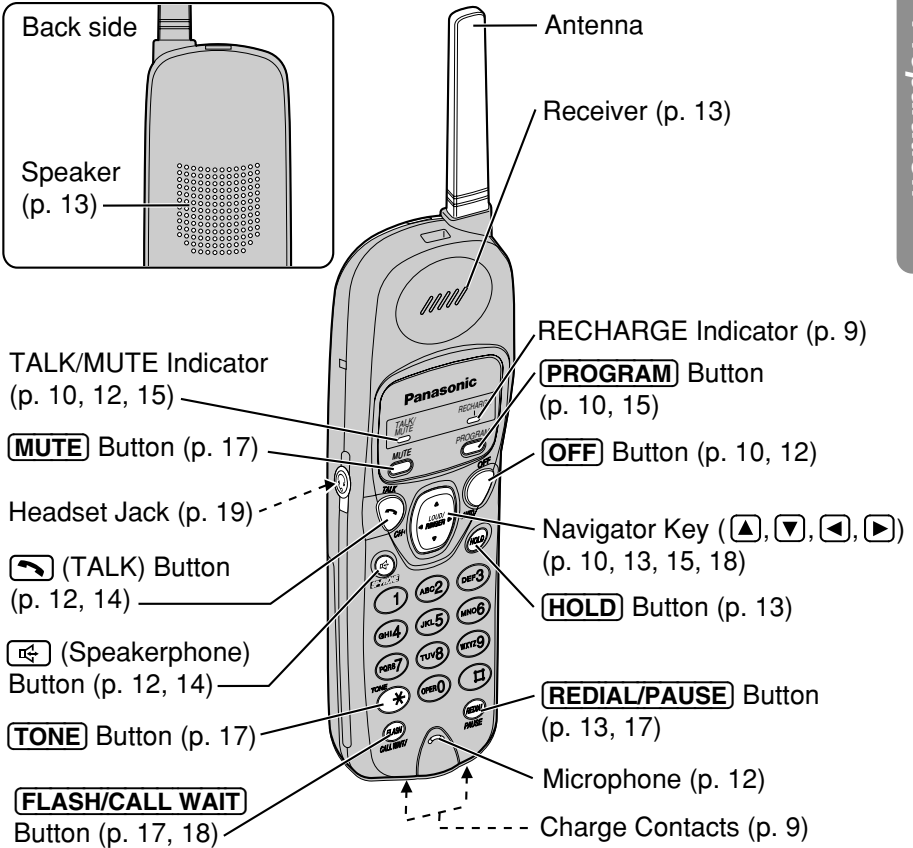

How to use the Navigator key

This key has four active areas that are indicated by arrows.

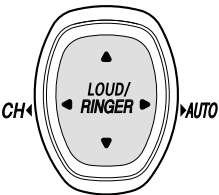

- Pressing the up or down arrow allows you to adjust the handset ringer and receiver/speaker volumes.
- Pressing the right or left arrow allows you to adjust the handset ringer pattern. The right arrow is used to set the dialing mode, the speed dialer or the flash time. The left arrow is used to select a clearer channel.

Throughout this Operating Instructions, the navigator key is indicated by the arrows , , or .

➔ Location of Controls

Base unit

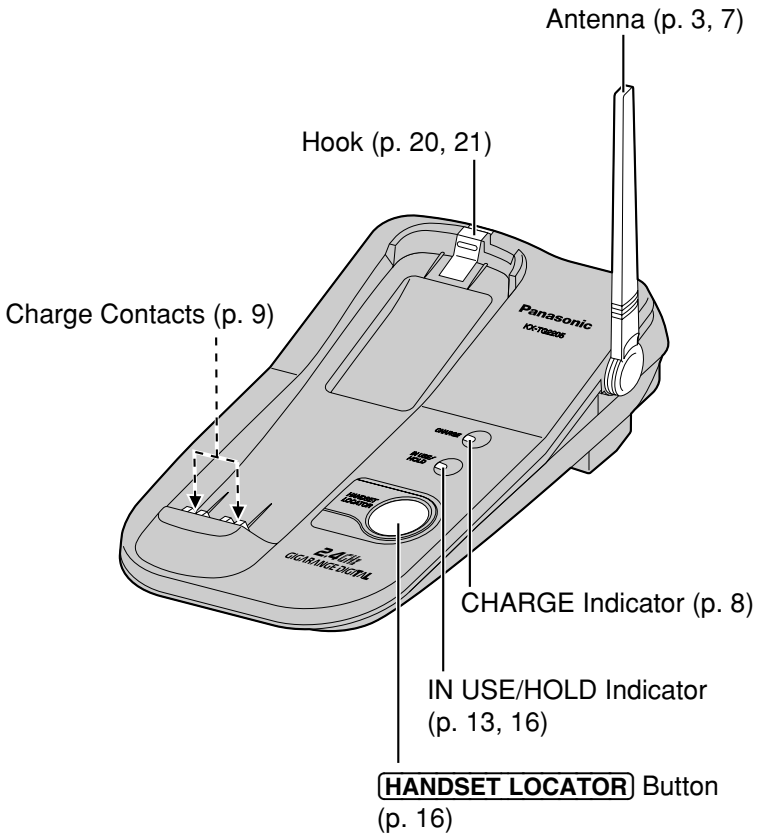

Settings



Connections

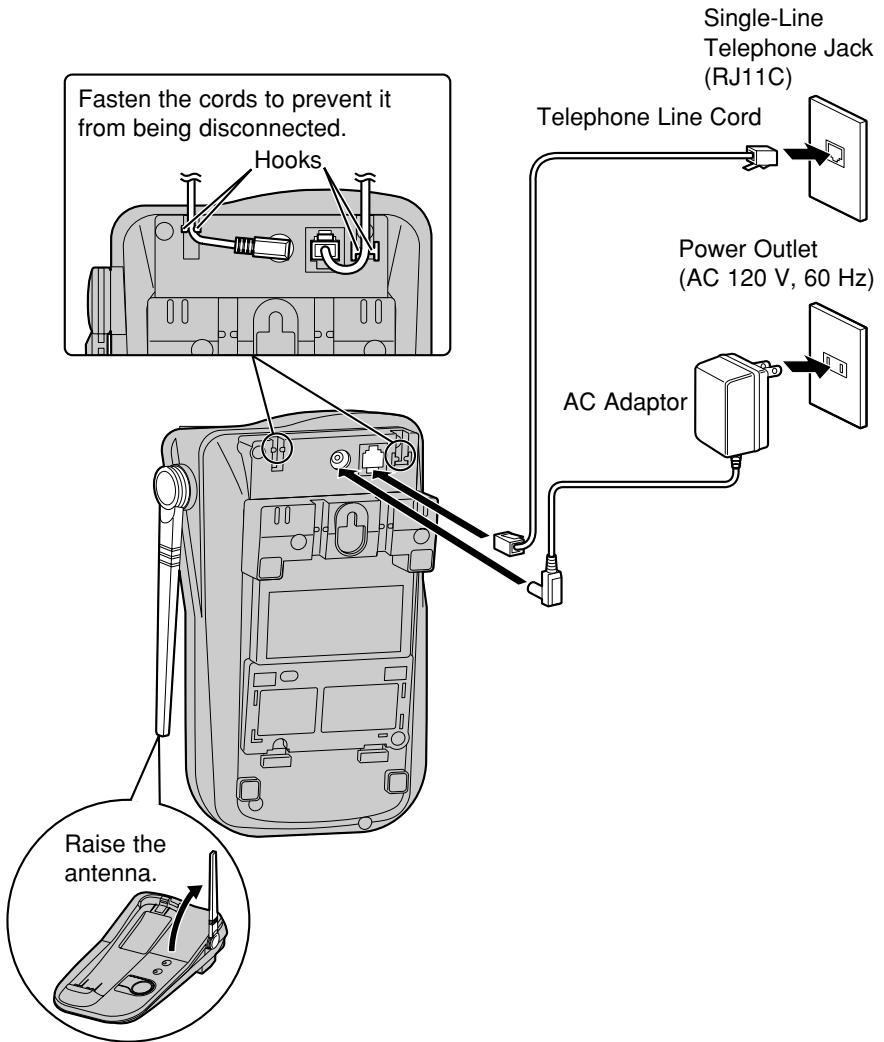

- USE ONLY WITH Panasonic AC ADAPTOR KX-TCA1 (Order No. KX-TCA1-G).
- The AC adaptor must remain connected at all times. (It is normal for the adaptor to feel warm during use.)
- To connect a standard telephone on the same line, see page 23.

➡ Settings

Installing the Battery in the Handset

Insert the battery into the handset as shown (①), matching the correct polarity. Press the battery down until it places into the compartment (②). When finished, close the cover.

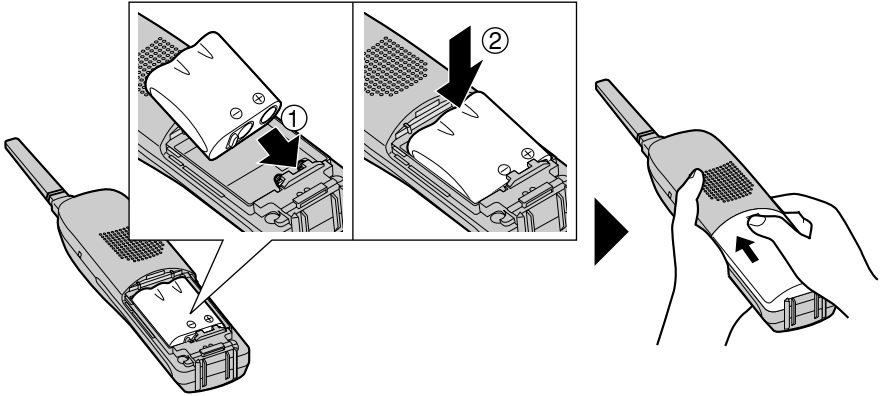

Battery Charge

Place the handset on the base unit and charge for about **15 hours** before initial use.

- The CHARGE indicator lights and a beep sounds.

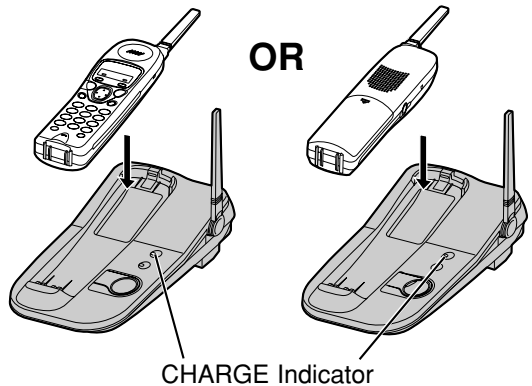



Recharge

When the RECHARGE indicator flashes or the unit beeps intermittently while it is use, place the handset on the base unit to recharge the battery for 15 hours.

- If you DO NOT recharge the handset battery for more than 15 minutes, the RECHARGE indicator will continue to flash.

RECHARGE
Indicator

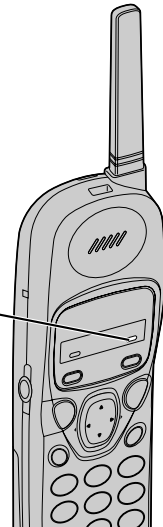

Battery information

After your Panasonic battery is fully charged (p. 8):

Operation	Operating time
While in use (TALK)	Up to 5 hours
While not in use (Standby)	Up to 11 days

- The battery operating time may be shortened depending on usage conditions and ambient temperature.
- Clean the handset and the base unit charge contacts with a soft, dry cloth once a month. Clean more often if the unit is subject to grease, dust or high humidity.** Otherwise the battery may not charge properly.
- If the battery is fully charged, you do not have to place the handset on the base unit until the RECHARGE indicator flashes. This will maximize the battery life.
- The battery cannot be overcharged.

➔ Settings

Dialing Mode

You can program the dialing mode using the handset near the base unit. If you have touch tone service, set to TONE. If rotary or pulse service is used, set to PULSE. Your phone comes from the factory set to TONE.

Make sure the unit is not being used and the handset is lifted off the base unit.

- 1 Press **PROGRAM**.
 - The TALK/MUTE indicator flashes.
- 2 Press **▶**.
- 3 To select PULSE, press **#** twice.
OR
To select TONE, press ***** twice.
- 4 Press **PROGRAM**.
 - A beep sounds.

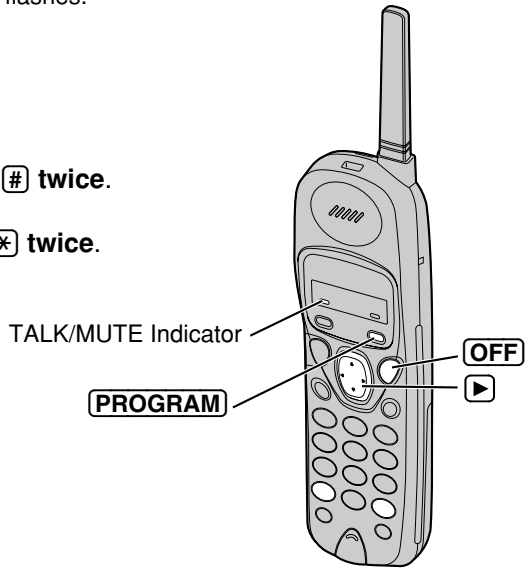



- You can exit the programming mode anytime by pressing **OFF**.
- If 3 beeps sound during programming,
 - a wrong key was pressed. Start again from step 1.
 - the handset is too far from the base unit. Move closer to the base unit or place the handset on the base unit. Start again from step 1.
- If you do not press any buttons for 60 seconds, the unit will exit the programming mode.

Ringer Volume





You can program the handset ringer volume to HIGH, LOW or OFF. If set to OFF, the handset will not ring. Your phone comes from the factory set to HIGH.

Make sure the unit is not being used and the handset is lifted off the base unit.

•To select HIGH (preset) or LOW, press  or .

Each time you press the button, the ringer volume will change and the selected volume will ring.



•To turn the ringer OFF, press and hold  until 2 beeps sound.

•To turn the ringer ON, press  or . The ringer will sound at the LOW level by pressing  or at the HIGH level by pressing .

Ringer Pattern



You can select the handset ringer pattern out of 6 patterns. When an incoming call is being received, the unit rings in the selected pattern.

Make sure the unit is not being used and the handset is lifted off the base unit.

1 Press  or .

•The unit rings at the current setting.

•If you set the ringer volume to OFF, the unit will not ring.

2 Within 5 seconds, select the desired ringer pattern by pressing  or .

•Each time you press the button, the ringer pattern will change and ring.

Making Calls

- 1 Press .
 - The TALK/MUTE indicator lights.
- 2 Dial a phone number.
- 3 To hang up, press **OFF** or place the handset on the base unit.
 - The indicator light goes out.

•If an alarm tone sounds in step 1, move closer to the base unit or place the handset on the base unit and try again.

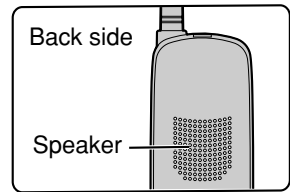

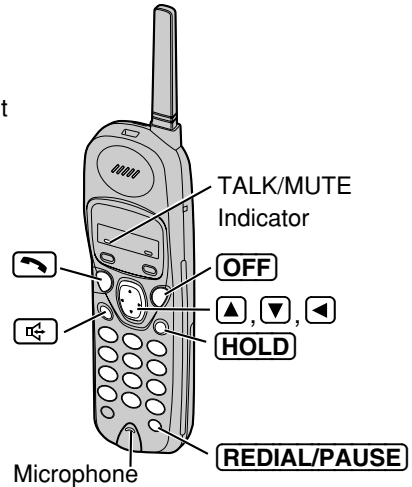

To have a hands-free phone conversation (Using Digital Duplex Speakerphone)

- 1 Press .
 - The TALK/MUTE indicator lights.
- 2 Dial a phone number.
- 3 When the other party answers, talk into the microphone.
- 4 To hang up, press **OFF** or place the handset on the base unit.
 - The indicator light goes out.



Hands-free Digital Duplex Speakerphone



For best performance, please note the following:

- Talk alternately with the caller in a quiet room.
- If the other party has difficulty hearing you, press **▼** to decrease the speaker volume.
- If the other party's voice from the speaker cuts in/out during a conversation, press **▼** to decrease the speaker volume.
- While talking using , you can switch to the hands-free phone conversation by pressing . To switch back to the receiver, press .



If noise interferes with the conversation

Press  to select a clearer channel in the talk mode, or move closer to the base unit.



To redial the last number dialed on the handset

Press  or  and press **REDIAL/PAUSE**.



To adjust the receiver volume (HIGH, MEDIUM or LOW) or speaker volume (6 levels) while talking

To increase, press . To decrease, press .

While using

- Each time you press  or , the volume level will change among 3 levels (HIGH, MEDIUM or LOW).
Your phone comes from the factory set to level MEDIUM.

While using



- Each time you press  or , the volume level will change among 6 levels.
Your phone comes from the factory set to level 3.
- When you replace the battery, the selected receiver/speaker volume setting will return to the factory set. Reprogram if necessary.

To put a call on hold

Press **HOLD**.

- The TALK/MUTE indicator and the IN USE/HOLD indicator flash.
- If you put a call on hold for more than 6 minutes, an alarm tone will sound. The call will be disconnected after a total of 10 minutes.

To release the hold

Lift the handset, or press  or .

- If another phone is connected on the same line (p. 23), you can also release the hold by lifting its handset.

Answering Calls

When a call is received, the unit rings and the IN USE/HOLD indicator on the base unit flashes quickly.

1 If the handset is off the base unit;
Press .

- You can also answer a call by pressing any dialing button **0** to **9**, ***** or **#** (**—Any Key Talk**).

OR



Press , and when the other party answers, talk into the microphone.

OR

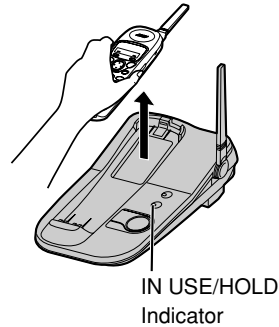
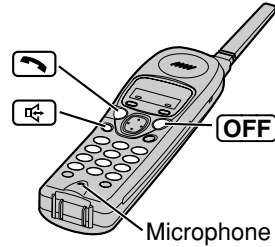
If the handset is on the base unit, just lift up.



2 To hang up, press **OFF** or place the handset on the base unit.

- You can select the ringer volume while a call is being received. Press  or  while the handset is just ringing. To set to OFF, press and hold .
- When the handset ringer volume is set to OFF, the unit will not ring (p. 11).

Speed Dialer

Storing Phone Numbers

You can store up to 10 phone numbers in the handset. The dialing buttons (0 to 9) function as memory stations.

Make sure the unit is not being used and the handset is lifted off the base unit.

- 1 Press **PROGRAM**.
 - The TALK/MUTE indicator flashes.
- 2 Enter a phone number up to 22 digits.
 - If you misdial, press **OFF** to end storing and start again from step 1.
- 3 Press **▶**.
- 4 Press a memory station number (0 to 9).
 - A beep sounds.
 - To store other numbers, repeat steps 1 through 4.

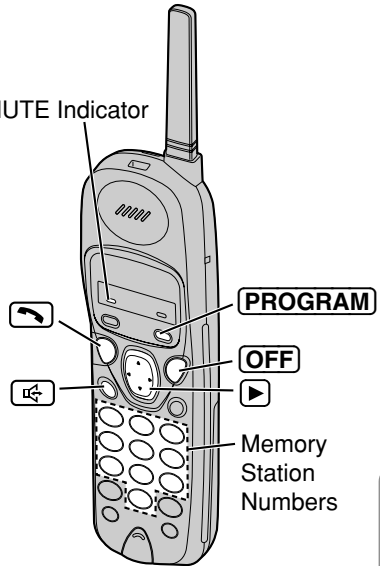

- If a pause is required for dialing, press **REDIAL/PAUSE** where needed. Pressing **REDIAL/PAUSE** counts as one digit (p. 17).

To erase a stored number

Press **PROGRAM** → **▶** → the memory station number (0 to 9) for the phone number to be erased.

Dialing a Stored Number

- 1 Press **☎** or **☎**.
- 2 Press **▶**.
- 3 Press the memory station number (0 to 9).

Special Features

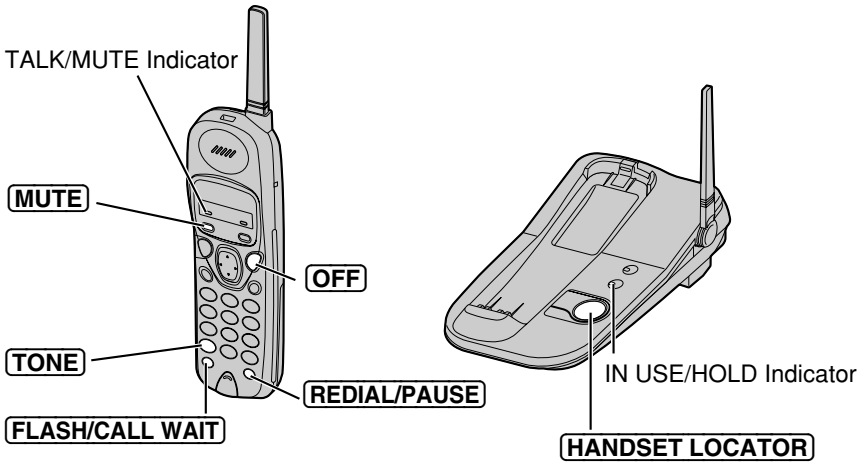

Automatic Security Code Setting

Each time you place the handset on the base unit, the unit automatically selects one of more than a million security codes. These codes help prevent the unauthorized use of your telephone line by another cordless telephone user.

Handset Locator

You can locate the handset or page the handset user with beep tones from the base unit.

- 1 Press **HANDSET LOCATOR**.
 - The IN USE/HOLD indicator flashes. The handset beeps for 1 minute.
- 2 To stop paging, press **HANDSET LOCATOR** again or press **OFF** on the handset.



Temporary Tone Dialing (For Rotary or Pulse Service Users)

Press **[TONE]** before entering access numbers which require tone dialing.

- The dialing mode changes to tone. You can enter numbers to access an answering service, electronic banking service, etc. When you hang up, the mode will return to pulse.

Muting Your Conversation

Press **[MUTE]** while talking.

- The TALK/MUTE indicator flashes.
- The other party cannot hear your voice but you can hear theirs.

To release the mute, press **[MUTE]**,  or .

For Call Waiting Service Users

Press **[FLASH/CALL WAIT]** if you hear a call-waiting tone while talking.

- The first call is put on hold and you can answer the second call.
- To return to the first caller, press **[FLASH/CALL WAIT]** again.
- The call waiting service cannot be used when a parallel connected telephone is in use.
- If this function does not operate properly, consult your telephone company for details.

How to Use the PAUSE Button (For Analog PBX Line/Long Distance Service Users)

We recommend you press **[REDIAL/PAUSE]** if a pause is required for dialing with a PBX or to access a long distance service.

Ex. Line access number **[9]** (PBX)

[9] → **[REDIAL/PAUSE]** → Phone number

- Pressing **[REDIAL/PAUSE]** once creates a 3.5 second pause. This prevents misdialing when you redial or dial a stored number.
- Pressing **[REDIAL/PAUSE]** more than once increases the length of the pause between numbers.

➔ Special Features

FLASH Button

Pressing **FLASH/CALL WAIT** allows you to use special features of your host PBX such as transferring an extension call or accessing special telephone services (optional) such as call waiting.

- Pressing **FLASH/CALL WAIT** causes to release following operations:
 - temporary tone dialing,
 - muting your conversation.

Selecting the flash time

The flash time depends on your telephone exchange or host PBX. You can select the following flash times: “700, 600, 400, 300, 250, 110, 100 or 90 ms (milliseconds)”. Your phone comes from the factory set to “700 ms”.

Make sure the unit is not being used and the handset is lifted off the base unit.

- 1 Press **PROGRAM**.
 - The TALK/MUTE indicator flashes.
- 2 Press a dialing button (**1** to **8**).

1 : 90 ms	2 : 100 ms
3 : 110 ms	4 : 250 ms
5 : 300 ms	6 : 400 ms
7 : 600 ms	8 : 700 ms
- 3 Press **▶**.
- 4 Press **FLASH/CALL WAIT**.
 - A beep sounds.

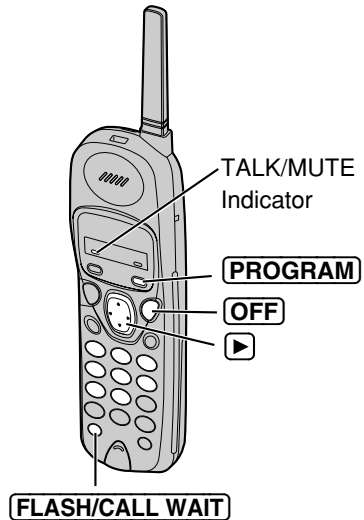

- You can exit the programming mode any time by pressing **OFF**.
- If the unit is connected via a PBX, PBX functions (transferring a call etc.) might not work correctly. Consult your PBX supplier for the correct setting.

Belt Clip

You can hang the handset on your belt or pocket using the belt clip.

To attach the belt clip

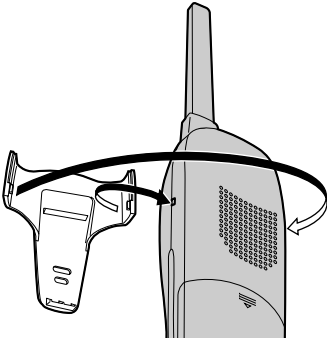

To remove the belt clip

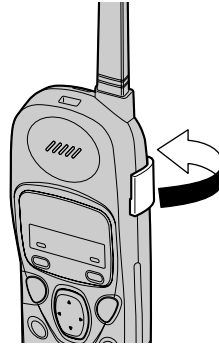

Optional Headset



Plugging an optional headset into the handset allows a hands-free phone conversation. Please use only a Panasonic KX-TCA88 or KX-TCA90 headset. To order, call the accessories telephone number on page 2.

Connecting an optional headset to the handset

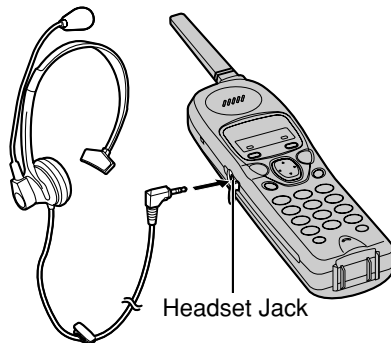
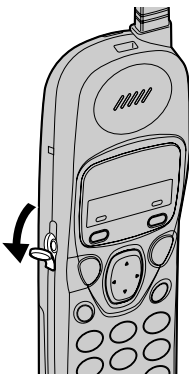
Open the headset jack cover, and connect an optional headset to the headset jack as shown below.



To switch to the speakerphone while using the headset:

Press . To return to the headset, press .

Wall Mounting

This unit can be mounted on a wall phone plate.

- 1 Push the hook and turn it around.
Turn the hook until a click is heard.

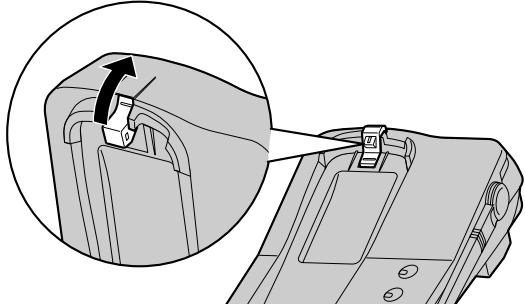

- 2 Connect the AC adaptor.

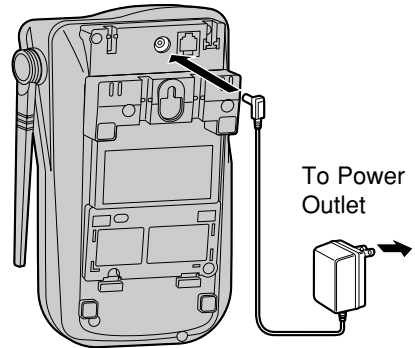

- 3 Tuck the telephone line cord inside the wall mounting adaptor, then push it in the direction of the arrow.
 - The word "UP" should face upward.

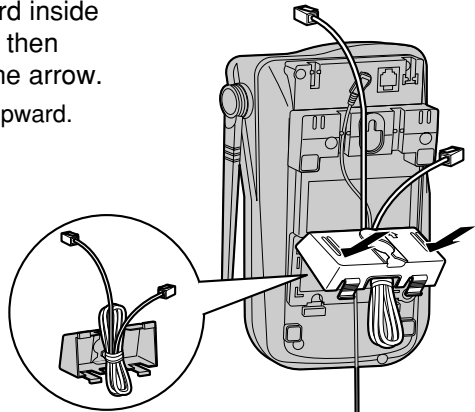

4 Connect the telephone line cord.
Mount the unit, then slide down.

- Raise the antenna.
- Fasten the telephone line cord to prevent it from being disconnected.

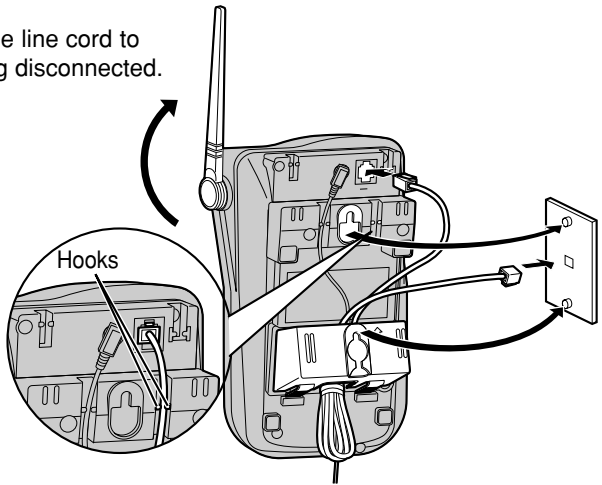

5 **To charge the handset battery:**
Fix the charge contacts (①) and insert the hook to the handset hole (②).

- The CHARGE indicator lights.

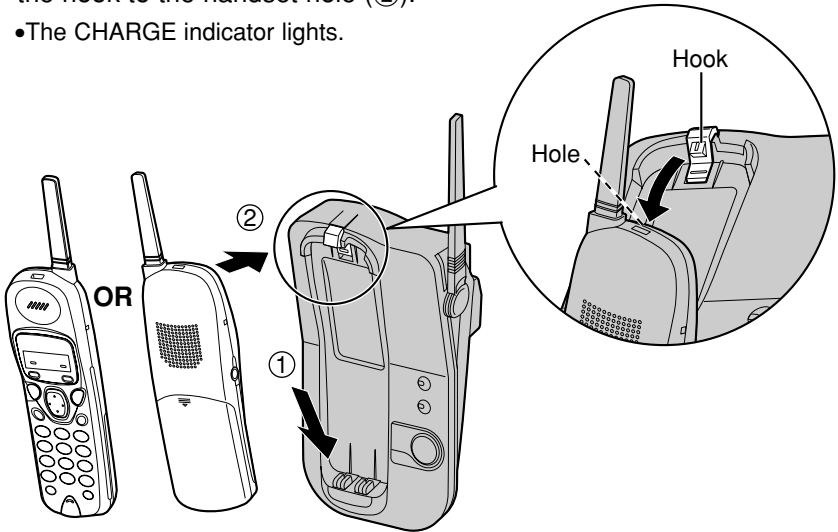

Battery Replacement

If the RECHARGE indicator flashes after being fully charged, replace the battery with a new Panasonic P-P511 (PQPP511SVC) battery. To order, call the accessories telephone number on page 2.

- 1 Press the notch on the handset cover firmly and slide it as indicated by the arrow.

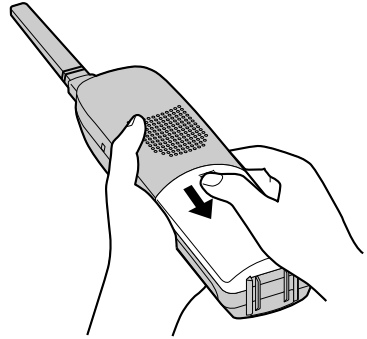

- 2 Remove the old battery. Insert the new battery into the handset as shown (①), matching the correct polarity. Press the battery down until it places into the compartment (②).

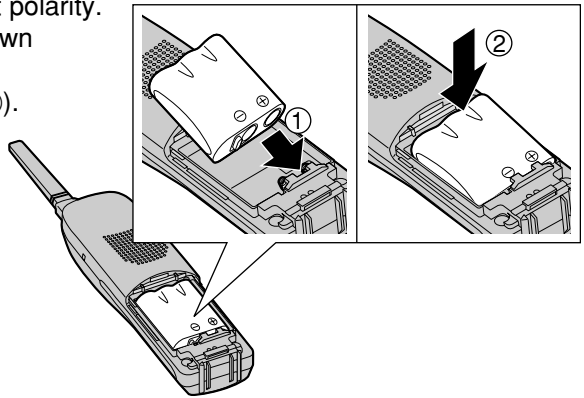

- 3 Close the cover. Make sure you charge the new battery for about 15 hours (p. 8).

A nickel cadmium battery that is recyclable powers the product you have purchased. At the end of its useful life, under various state and local laws, it is illegal to dispose of this battery into your municipal waste stream. Please call 1-800-8-BATTERY for information on how to recycle this battery.





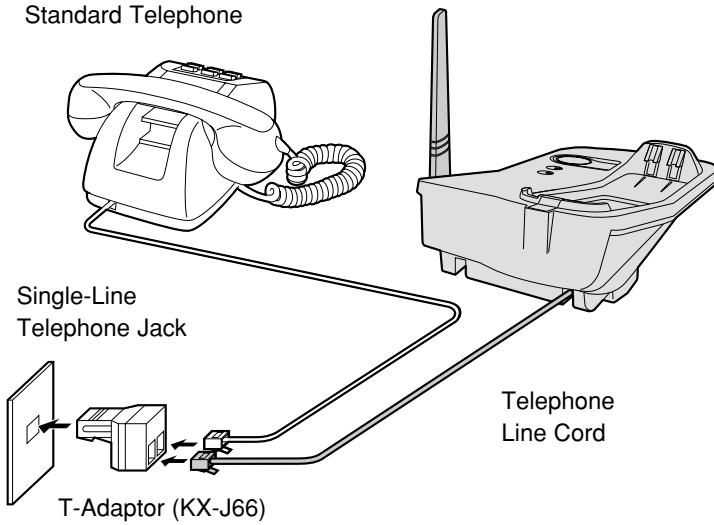

Adding Another Phone

This unit will not function during a power failure. To connect a standard telephone on the same line, use the Panasonic T-adaptor KX-J66. To order, call the accessories telephone number on page 2.



Troubleshooting

Problem	Remedy
The unit does not work.	<ul style="list-style-type: none">•Check the settings (p. 7–11).•Charge the battery fully (p. 8).•Clean the charge contacts and charge again (p. 9).•Install the battery properly (p. 8).•Place the handset on the base unit and unplug the AC adaptor to reset. Plug in, and try again.•Re-install the battery and place the handset on the base unit (p. 22). Try again.
An alarm tone sounds.	<ul style="list-style-type: none">•You are too far from the base unit. Move closer and try again.•Place the handset on the base unit and try again.•Plug in the AC adaptor.•Raise the base unit antenna.
Static, sound cuts in/out, fades. Interference from other electrical units.	<ul style="list-style-type: none">•Locate the handset and the base unit away from other electrical appliances (p. 3).•Move closer to the base unit.•Raise the base unit antenna.•Press  to select a clearer channel in the talk or speakerphone mode.
The unit does not ring.	<ul style="list-style-type: none">•The ringer volume is set to OFF. Set to HIGH or LOW (p. 11).
You cannot program items such as the dialing mode.	<ul style="list-style-type: none">•Programming is not possible while the unit is in the talk mode.•Do not pause for over 60 seconds while programming.•Move closer to the base unit.
Previously programmed information is erased.	<ul style="list-style-type: none">•If a power failure occurs, programmed information may be erased. Reprogram if necessary.
You cannot store a phone number in memory.	<ul style="list-style-type: none">•You cannot store a number while the unit is in the talk mode.•Do not pause for over 60 seconds while storing.

Problem	Remedy
While storing a phone number, the unit starts to ring.	<ul style="list-style-type: none"> •To answer the call, press  or . Start again from the beginning after hanging up.
You cannot page the handset.	<ul style="list-style-type: none"> •The handset is too far from the base unit. •The handset is engaged in an outside call. Wait until the IN USE/HOLD indicator light goes out.
You cannot redial by pressing REDIAL/PAUSE .	<ul style="list-style-type: none"> •If the last number dialed was more than 32 digits long, the number will not be redialed correctly. •The button has a double function as either redial or pause. It will redial the last number dialed if pressed at the outset of a call (p. 13). If another number has been dialed first, it will operate as a pause button (p. 17).
The RECHARGE indicator flashes or the unit beeps intermittently.	<ul style="list-style-type: none"> •Charge the battery fully (p. 8).
You charged the battery fully, but the RECHARGE indicator flashes.	<ul style="list-style-type: none"> •Clean the charge contacts and charge again (p. 9). •Install a new battery (p. 22).
The CHARGE indicator light does not go out after the battery has been charged.	<ul style="list-style-type: none"> •This is normal.
You cannot have a conversation using the headset.	<ul style="list-style-type: none"> •Make sure that an optional headset is connected properly (p. 19). • may have been pressed, press  to continue the conversation with the headset.
If you cannot solve your problem	<ul style="list-style-type: none"> •Call our customer call center at 1-800-211-PANA(7262). •Panasonic's e-mail address for customer inquiries: consumerproducts@panasonic.com for customers in the USA or Puerto Rico ONLY.

Important Safety Instructions

When using this unit, basic safety precautions should always be followed to reduce the risk of fire, electric shock, or personal injury.

1. Read and understand all instructions.
2. Follow all warnings and instructions marked on this unit.
3. Unplug this unit from AC outlets before cleaning. Do not use liquid or aerosol cleaners. Use a damp cloth for cleaning.
4. Do not use this unit near water, for example, near a bathtub, washbowl, kitchen sink, or the like.
5. Place this unit securely on a stable surface. Serious damage and/or injury may result if the unit falls.
6. Do not cover slots and openings on the unit. They are provided for ventilation and protection against overheating. Never place the unit near radiators, or in a place where proper ventilation is not provided.
7. Use only the power source marked on the unit. If you are not sure of the type of power supplied to your home, consult your dealer or local power company.
8. Do not place objects on the power cord. Install the unit where no one can step or trip on the cord.
9. Do not overload wall outlets and extension cords. This can result in the risk of fire or electric shock.
10. Never push any objects through slots in this unit. This may result in the risk of fire or electric shock. Never spill any liquid on the unit.
11. To reduce the risk of electric shock, do not disassemble this unit. Take the unit to an authorized servicer when service is required. Opening or removing covers may expose you to dangerous voltages or other risks. Incorrect reassembly can cause electric shock when the unit is subsequently used.
12. Unplug this unit from the wall outlet and refer servicing to an authorized servicer when the following conditions occur:
 - A. When the power supply cord or plug is damaged or frayed.
 - B. If liquid has been spilled into the unit.
 - C. If the unit has been exposed to rain or water.
 - D. If the unit does not work normally by following the operating instructions. Adjust only controls covered by the operating instructions. Improper adjustment may require extensive work by an authorized servicer.
 - E. If the unit has been dropped or physically damaged.
 - F. If the unit exhibits a distinct change in performance.
13. During thunderstorms, avoid using telephones except cordless types. There may be a remote risk of an electric shock from lightning.
14. Do not use this unit to report a gas leak, when in the vicinity of the leak.

SAVE THESE INSTRUCTIONS

CAUTION:

To reduce the risk of fire or injury to persons, read and follow these instructions.

1. Use only the battery(ies) specified.
2. Do not dispose of the battery(ies) in a fire. They may explode. Check with local waste management codes for special disposal instructions.
3. Do not open or mutilate the battery(ies). Released electrolyte is corrosive and may cause burns or injury to the eyes or skin. The electrolyte may be toxic if swallowed.
4. Exercise care in handling batteries in order not to short the battery to conductive materials such as rings, bracelets, and keys. The battery and/or conductor may overheat and cause burns.
5. Charge the battery(ies) provided with or identified for use with this product only in accordance with the instructions and limitations specified in this manual.

WARNING:

TO PREVENT FIRE OR SHOCK HAZARD, DO NOT EXPOSE THIS PRODUCT TO RAIN OR ANY TYPE OF MOISTURE.

- The AC adaptor is used as the main disconnect device, ensure that the AC outlet is located/installed near the unit and is easily accessible.

FCC and Other Information

If requested by the telephone company, inform them as follows:

Registration No.(found on the bottom of the unit)

Ringer Equivalence0.1B

The particular telephone line to which the equipment is connected.

This unit must not be connected to a coin operated line.

If you are on a party line, check with your local telephone company.

Ringer Equivalence No. (REN):

The REN is useful in determining the quantity of devices you may connect to your telephone line and still have all of those devices ring when your telephone number is called. In most, but not all areas, the sum of the REN's of all devices connected to one line should not exceed five (5.0). To be certain of the number of devices you may connect to your line, as determined by the REN, you should contact your local telephone company to determine the maximum REN for your calling area.

In the event terminal equipment causes harm to the telephone network, the telephone company should notify the customer, if possible, that service may be stopped.

However, where prior notice is impractical, the company may temporarily cease service providing that they:

- (a) Promptly notify the customer.
- (b) Give the customer an opportunity to correct the problem with their equipment.
- (c) Inform the customer of the right to bring a complaint to the Federal Communication Commission pursuant to procedures set out in FCC Rules and Regulations Subpart E of Part 68.

The Telephone Company may make changes in its communications facilities, equipment, operations or procedures, where such action is reasonably required in the operation of its business and is not inconsistent with the rules and regulations in 47 CFR Part 68.

If such changes can be reasonably expected to render any customer terminal equipment incompatible with telephone company communications facilities, or require modification or alteration of such terminal equipment, or otherwise materially affect its use or performance, the customer shall be given adequate notice in writing, to allow the customer an opportunity to maintain uninterrupted service.

When programming emergency numbers and/or making test calls to emergency numbers:

1. Remain on the line and briefly explain to the dispatcher the reason for the call before hanging up.
2. Perform such activities in the off-peak hours, such as early morning hours or late evenings.

This device complies with Part 15 of the FCC Rules. Operation is subject to the following two conditions: (1) This device may not cause harmful interference, and (2) this device must accept any interference received, including interference that may cause undesired operation.

Privacy of communications may not be ensured when using this phone.

**CAUTION:**

Any changes or modifications not expressly approved by the party responsible for compliance could void the user's authority to operate this device.

Note:

This equipment has been tested and found to comply with the limits for a Class B digital device, pursuant to Part 15 of the FCC Rules. These limits are designed to provide reasonable protection against harmful interference in a residential installation. This equipment generates, uses, and can radiate radio frequency energy and, if not installed and used in accordance with the instructions, may cause harmful interference to radio communications. However, there is no guarantee that interference will not occur in a particular installation. If this equipment does cause harmful interference to radio or television reception, which can be determined by turning the equipment off and on, the user is encouraged to try to correct the interference by one or more of the following measures:

- Reorient or relocate the receiving antenna.
- Increase the separation between the equipment and receiver.
- Connect the equipment into an outlet on a circuit different from that to which the receiver is connected.
- Consult the dealer or an experienced radio/TV technician for help.

Some cordless telephones operate at frequencies that may cause interference to nearby TVs and VCRs. To minimize or prevent such interference, the base of the cordless telephone should not be placed near or on top of a TV or VCR. If interference is experienced, move the cordless telephone further away from the TV or VCR. This will often reduce, or eliminate, interference.

Operating near 2.4GHz electrical appliances may cause interference. Move away from the electrical appliances and/or press the CH (Channel) button.

CAUTION:

To comply with FCC RF exposure requirements, the base unit should be installed with its antenna located at 20 cm or more from persons and handset should be carried with the specific belt-clip provided for the handset to ensure compliance. Other non-tested belt-clips or similar body-worn accessories may not comply, therefore, should be avoided.

This equipment is hearing aid compatible.

A TIA/EIA-IS-968 compliant telephone cord and modular plug is provided with this equipment. This equipment is designed to be connected to the telephone network or premises wiring using a compatible modular jack that is also TIA/EIA-IS-968 compliant.

➔ FCC and Other Information

- **Environment** — do not place the unit in a room where the temperature is less than 5°C (41°F) or greater than 40°C (104°F). Allow 10 cm (4") clearance around the unit for proper ventilation. Avoid excessive smoke, dust, mechanical vibration, shock, or direct sunlight.
- **Medical** — consult the manufacturer of any personal medical devices, such as pacemakers, to determine if they are adequately shielded from external RF (radio frequency) energy. (The unit operates in the frequency range of 2402MHz to 2480MHz, and the power output level can range 0.015 watts.) Do not use the unit in health care facilities if any regulations posted in the area instruct you not to do so. Hospitals or health care facilities may be using equipment that could be sensitive to external RF (radio frequency) energy.
- **Routine care** — wipe the unit with a soft cloth. Do not use benzine, thinner, or any abrasive powder. When you leave the unit unused for a long period of time, unplug the AC adaptor from the outlet.
- **If there is any trouble** — disconnect the unit from the telephone line and connect a known working phone. If the known working phone operates properly, have your unit repaired by one of the authorized Panasonic Factory Service Centers. If the known working phone does not operate properly, consult your telephone company.

Index

A Accessories	2	L Location of controls	5, 6
Answering calls	14	M Making Calls	12
Automatic Security Code Setting ..	16	Microphone	12
B Base location	3	Muting a conversation	17
Battery Charge	3, 8	N Noise	3
Battery information	9	P PAUSE	17
Battery replacement	22	Pulse service	17
Belt Clip	19	R Redial	13
C Call on hold	13	Ringer Off	11
Call waiting tone	17	Ringer Pattern	11
D Dialing mode	10	Ringer Volume	11
F FCC and other information	28	Rotary service, tone dialing	17
FLASH button	18	S Safety Instructions	26
Flash time	18	Shipping product for service	
H Handset Locator	16 Back cover	
Headset, optional	19	Speakerphone	12
Hold alarm	13	Speed Dialer	
I Installation		Dialing	15
AC adaptor	7	Storing	15
Adding another phone	23	T Troubleshooting	24
Battery	8	V Volume control	13
Telephone line cord	7		

For product service

- Call 1-800-211-PANA(7262) for the location of an authorized servicer.
- Panasonic's e-mail address for customer inquiries:
consumerproducts@panasonic.com
for customers in the USA or Puerto Rico ONLY

When you ship the product

- Carefully pack your unit, preferably in the original carton.
- Attach a letter, detailing the symptom, to the outside of the carton.

Symptom

- Send the unit to an authorized servicer, prepaid and adequately insured.
- Do not send your unit to the Panasonic Consumer Electronics Company listed below or to executive or regional sales offices. These locations do not repair consumer products.

- This cordless telephone is designed for use in the United States of America. Sale or use of this product in other countries may violate local laws.
- Ce téléphone sans fil est conçu pour être utilisé aux États-Unis d'Amérique. La vente ou l'emploi de cet appareil dans certains autres pays peut constituer une infraction à la législation locale.
- Este teléfono sin cordón fue elaborado para uso en los Estados Unidos de América. La venta o el empleo de este producto en ciertos países puede constituir violación de la legislación local.
- このコードレス電話機は、日本国外での使用を目的として設計されており、日本国内での使用は法律違反となります。従って、当社では日本国内においては原則として修理などのサービスは致しかねます。

**If you need assistance with the set-up or operation,
please call 1-800-211-PANA(7262)**

**Panasonic Consumer Electronics Company,
Division of Matsushita Electric Corporation of America**
One Panasonic Way, Secaucus, New Jersey 07094

**Panasonic Sales Company,
Division of Matsushita Electric of Puerto Rico, Inc.**
Ave. 65 de Infantería, Km. 9.5, San Gabriel Industrial Park
Carolina, Puerto Rico 00985