

Panasonic

2.4GHz Cordless Phone

Model No. **KX-TG2650N**

Pulse-or-tone dialing capability

Operating Instructions



Caller ID Compatible

PLEASE READ BEFORE USE AND SAVE.

Charge the battery for about 8 hours before initial use.

Panasonic World Wide Web address: <http://www.panasonic.com>
for customers in the USA or Puerto Rico

Preparation

Basic Operation

Advanced Operation

Useful Information

Before Initial Use

Please read **IMPORTANT SAFETY INSTRUCTIONS** on page 64 before use.
Read and understand all instructions.

Thank you for purchasing your new Panasonic cordless telephone.

Caller ID and Call Waiting Service, where available, are telephone company services. After subscribing to Caller ID, this phone will display a caller's name and phone number. Call Waiting Caller ID, which displays a second caller's name and phone number while the user is on another call, requires a subscription to both Caller ID and Call Waiting.

Attach your purchase receipt here.

For your future reference

Serial No.
(found on the bottom of the unit)

Date of purchase

Name and address of dealer

Accessories (included) For extra orders, call 1-800-332-5368.

- AC Adaptor (p. 10)
Order No. PQWATG2650N

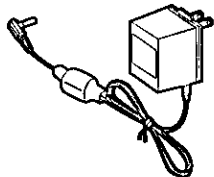

one

- Telephone Line Cord (p. 10)

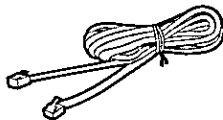

one

- Wall Mounting Adaptor (p. 52)
Order No. PQKL10038Z1

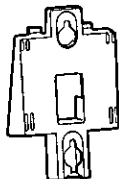

one

- Belt Clip (p. 53)
Order No. PQKE10109Z1



one

For Best Performance

Battery Charge

A rechargeable Nickel-Metal Hydride (Ni-MH) battery powers the handset. Charge the battery for about **8 hours** before initial use (p. 11).



Base Unit Location/Noise

Calls are transmitted between the base unit and the handset using wireless radio waves. **For maximum distance and noise-free operation**, the recommended base unit location is:

Away from electrical appliances such as a TV, personal computer or another cordless phone.

In a **HIGH** and **CENTRAL** location with no obstructions such as walls.

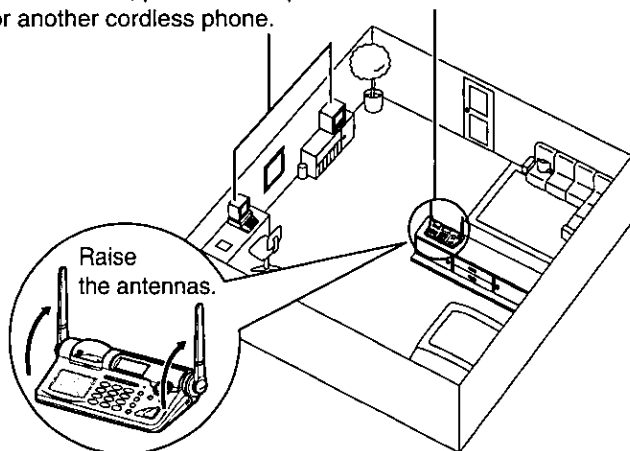

For best performance, extend the handset antenna fully.

- If the antenna is only extended half-way, better operating range is not available.

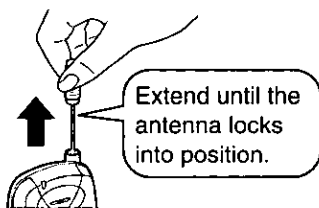

Note:

While using the handset:

- If you are near a microwave oven which is being used, noise may be heard from the receiver or the speaker. Move away from the microwave oven and closer to the base unit.
- If more than one cordless phone is being used and your handset is near another cordless phone's base unit, noise may be heard. Move away from the other cordless phone's base unit and closer to your base unit.

Contents

Preparation

Location of Controls	6
Displays	9
Settings	10
Connections	10
Battery Charge	11
Selecting the Dialing Mode	13
Selecting the Line Mode	14
Programmable Functions	15
Setting the Auto Talk Feature	16
Selecting the Ringer Volume	17

Basic Operation

Making Calls	18
With the Handset	18
With the Base Unit	21
Simultaneous Keypad Dialing	23
Answering Calls	24
With the Handset	24
With the Base Unit	25

Advanced Operation

Caller ID Service	26
Using the Caller List	28
Viewing the Caller List	28
Calling Back from the Caller List	29
Editing the Caller's Phone Number	30
Storing Caller List Information in the Directory	32
Erasing Caller List Information	33
One-Touch Dialer	34
Storing a Phone Number in the DIRECT Button	34
Dialing the Stored Number in the DIRECT Button	35
Using the Directory	35
Storing Names and Numbers in the Directory	36
Selecting Characters to Enter Names	38
Finding Items in the Directory	40
Dialing from the Directory	41
Editing an Item in the Directory	42
Erasing an Item from the Directory	43

Intercom	44
Transferring a Call Using the Intercom	45
Voice Mail Service	46
Storing a Voice Mail Access Number	46
Setting the Voice Mail Tone	47
Listening to Voice Mail Messages	48
Special Features	49
Automatic Security Code Setting	49
How to Use the PAUSE Button (For Analog PBX Line/Long Distance Service Users)	49
For Call Waiting Service Users	50
Temporary Tone Dialing (For Rotary or Pulse Service Users)	50
FLASH Button	51

Useful Information

Wall Mounting	52
Using the Belt Clip	53
Using an Optional Headset	54
Adding Another Phone	55
Fashion Plate™ Snap-On Color Covers (Optional)	56
Battery Replacement	58
If the Following Appear...	59
Before Requesting Help	60
Important Safety Instructions	64
FCC and Other Information	66

Preparation

Basic Operation

Advanced Operation

Useful Information

Location of Controls

Base unit

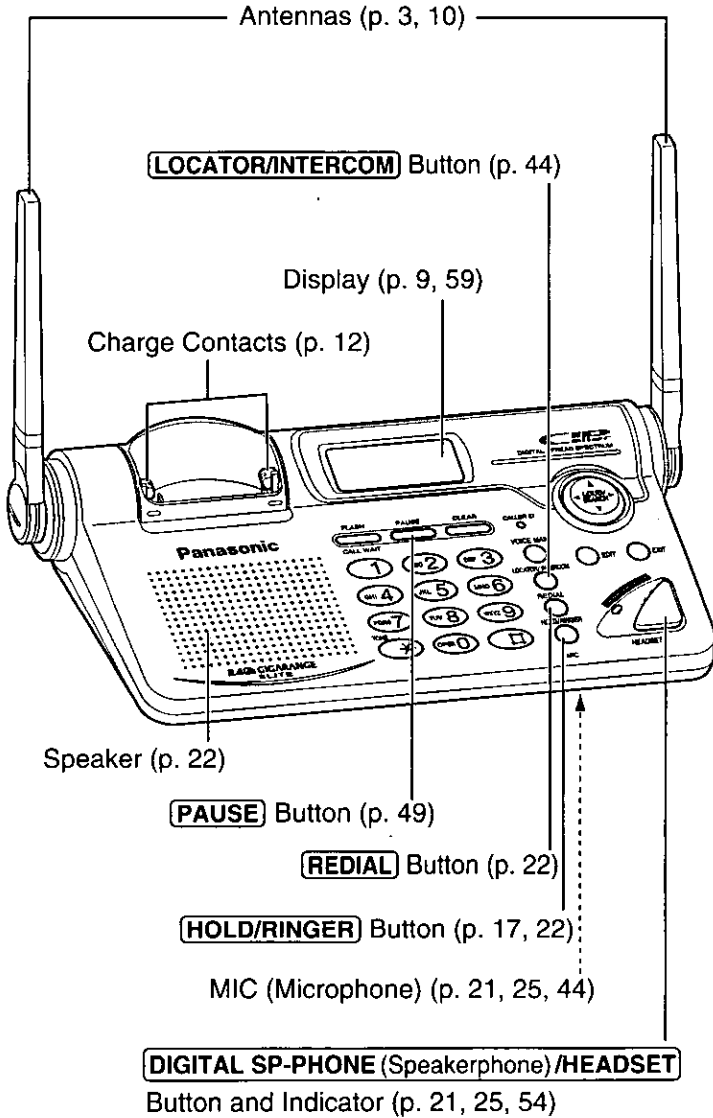

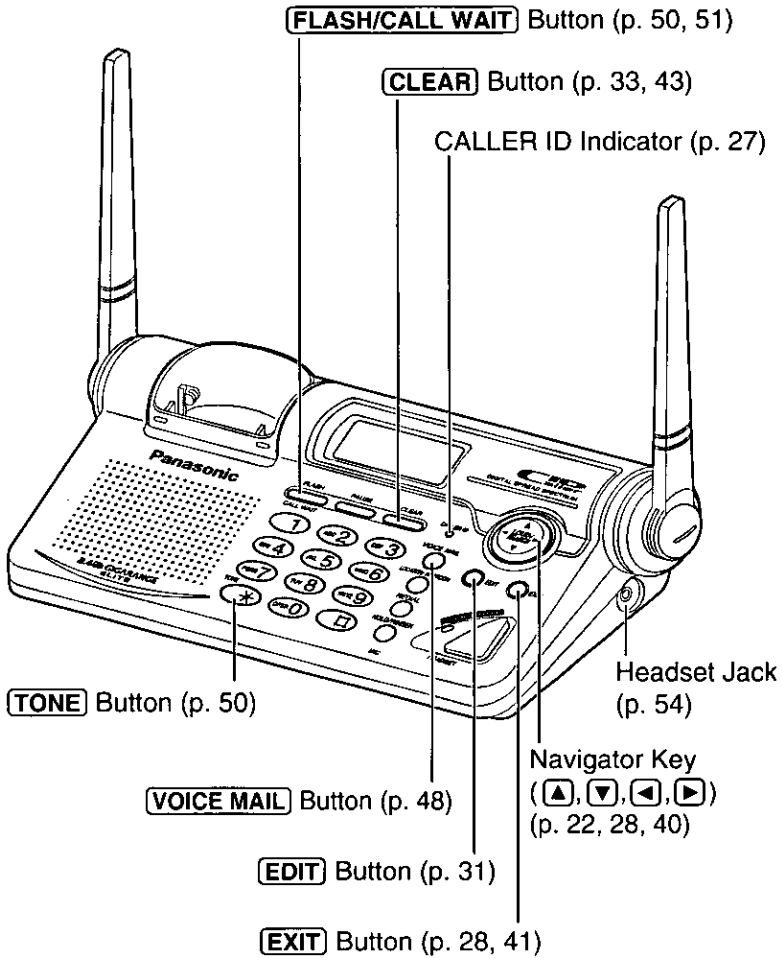

➔ Location of Controls

Handset

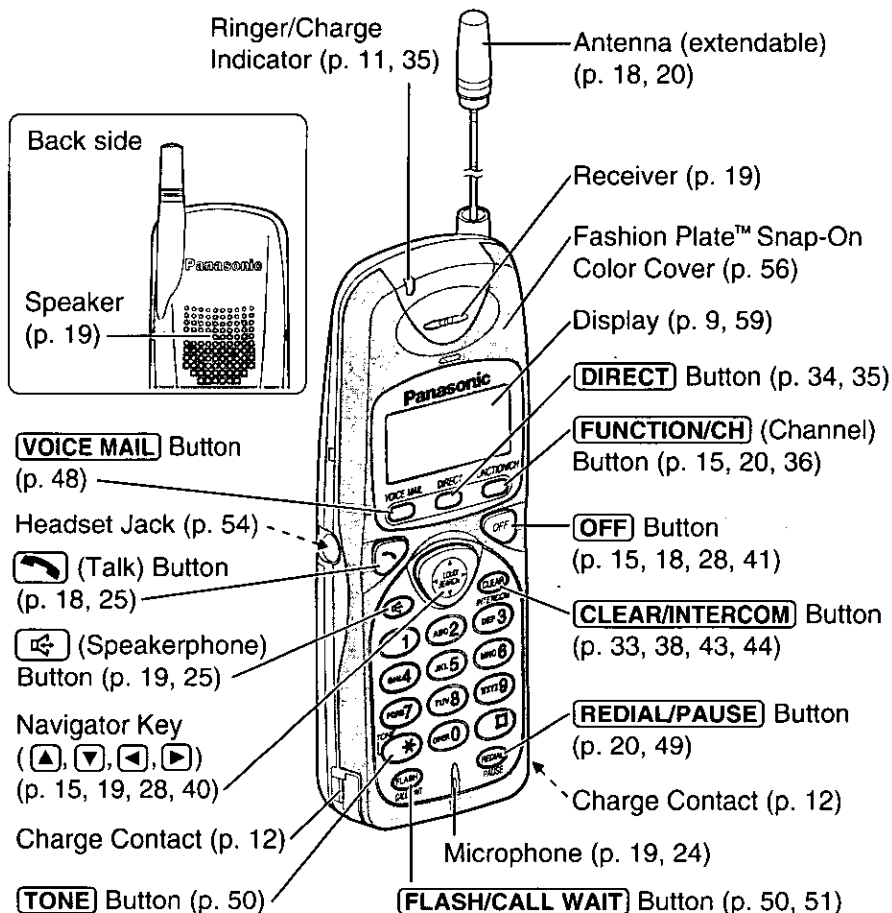

How to handle the handset antenna:

You can even use the handset without extending the antenna. But for best performance, extend the antenna fully until it locks into position.

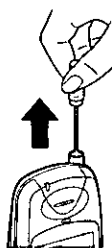

To put away the antenna, slide down vertically holding the lower part until it stops.

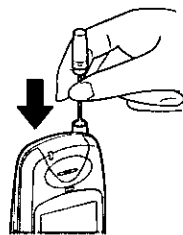

Displays

Handset

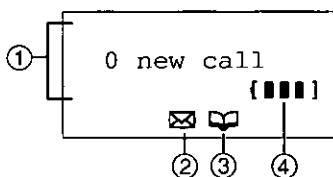

① The display shows the dialed number, call status, programming options and directory items etc. If you subscribe to a Caller ID service, caller information will be displayed (p. 26). The number of new calls will also be displayed.

- ② The voice mail icon indicates you have received voice mail messages (p. 46).
- ③ The directory icon displays when storing or viewing the directory items (p. 36, 40).
- ④ The battery icon indicates the battery strength (p. 11).

Standby mode:

While the handset is off the base unit, the display becomes blank after you finish using the handset (making/answering a call, viewing the Caller List or directory list etc.). The handset can receive calls. The battery life is conserved in this state. While the handset is on the base unit, the battery icon and the number of new Caller ID calls are displayed in the standby mode (p. 27).

Base unit

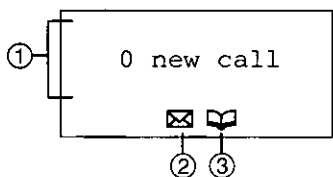

① The display shows the dialed number, call status, programming options and directory items etc. If you subscribe to a Caller ID service, caller information will be displayed (p. 26). The number of new calls will also be displayed.

- ② The voice mail icon indicates you have received voice mail messages (p. 46).
- ③ The directory icon displays when viewing the directory items (p. 40).

Backlight LCD Displays

The handset and the base unit have the backlight LCD displays. Each display will light when you start using the handset or the base unit, and when a call is received. The handset display light will stay on for about 10 seconds after pressing a button or lifting the handset off the base unit. The base unit display light will go out after use.

You can change the backlight color to orange for certain callers by storing them in the directory (p. 35).

Settings

Connections

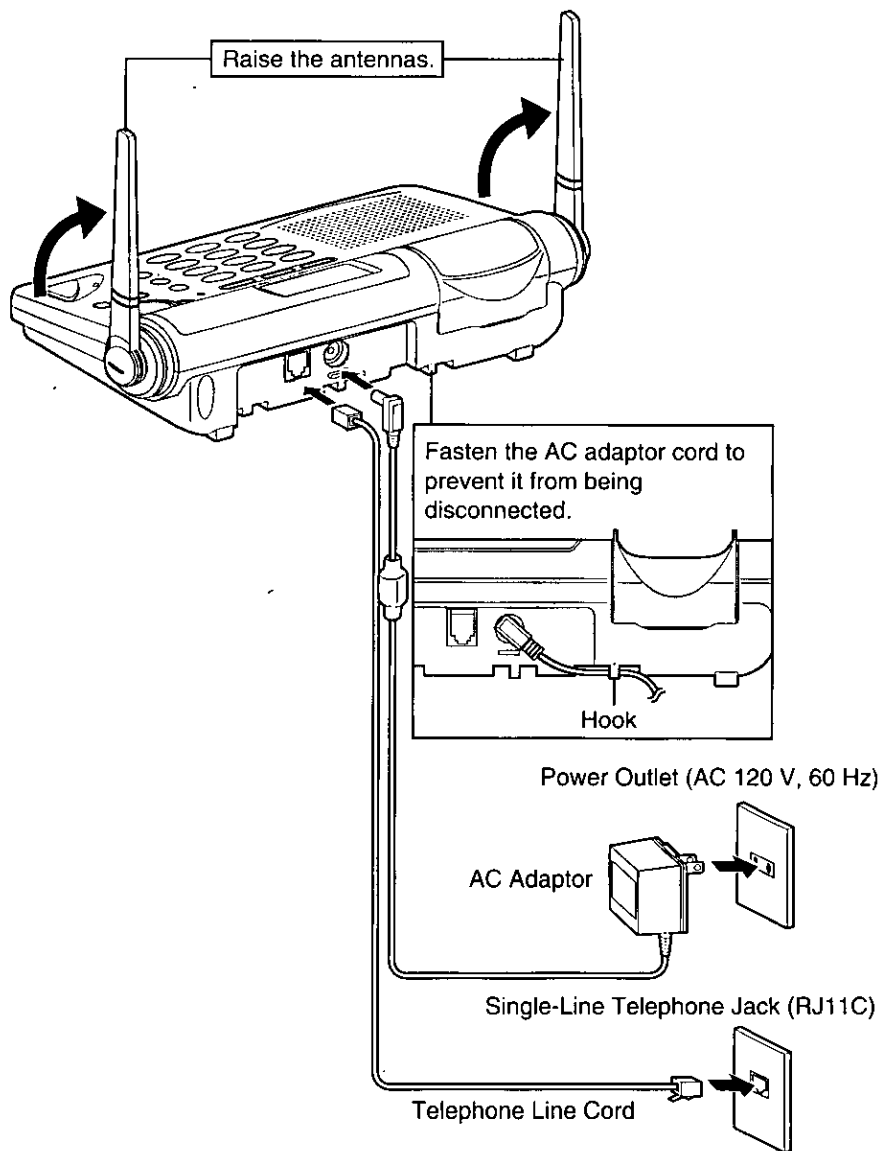

- USE ONLY WITH Panasonic AC ADAPTOR PQLV10 (Order No. PQWATG2650N).
- The AC adaptor must remain connected at all times. (It is normal for the adaptor to feel warm during use.)
- To connect a standard telephone on the same line, see page 55.
- If your unit is connected to a PBX which does not support Caller ID and voice mail services, you cannot access those services.



Battery Charge

Insert the handset in the cradle. The ringer/charge indicator will light and a beep will sound. Charge for about **8 hours** before initial use.

- If the battery has been fully charged, the ringer/charge indicator light will turn from red to green.
- If you use the handset for a few minutes, the ringer/charge indicator light will stay red for a while even if the battery is fully charged. This is normal.

Ringer/Charge Indicator

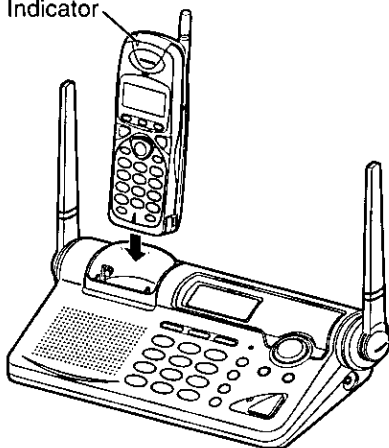

Battery strength

You can check the battery strength on the handset display while the handset is on the base unit, while it is in use (making/answering a call etc.), or after viewing the Caller List or directory items, programming etc. The battery strength will remain for 5 seconds after using the handset, then the display will return to the standby mode (p. 9).

The battery strength is as shown in the chart below.

Display prompt	Battery strength
{ ■■■ }	High
{ ■■ }	Medium
{ ■ }	Low
⚡ { ■ } ⚡ (flashing)	Needs to be recharged.

- If the battery has been fully charged, the ringer/charge indicator will light in green.

➔ Settings

Recharge

Recharge the battery when:

- “Recharge battery” is displayed on the handset,
- “{ ■}” flashes on the display, or
- the handset beeps intermittently while it is in use.

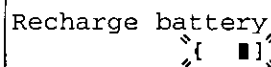

Recharge battery
{ ■}

- If you DO NOT recharge the handset battery for more than 15 minutes, the display will keep indicating “Recharge battery” and/or “{ ■}” will continue to flash.

Battery information

After your Panasonic battery is fully charged (p. 11):

Operation		Approx. battery life
While in use (TALK)	near the base unit*	Up to 4.5 hours
	away from the base unit	Up to 3.5 hours
While not in use (Standby)		Up to 11 days

*Within about 10 feet (3 m)

- Battery life may be shortened depending on usage conditions, such as viewing the Caller ID Caller List or directory list, and ambient temperature.
- Clean the handset and the base unit charge contacts with a soft, dry cloth once a month. Clean more often if the unit is subject to grease, dust or high humidity.** Otherwise the battery may not charge properly.
- If the battery is fully charged, you do not have to place the handset on the base unit until “Recharge battery” is displayed and/or “{ ■}” flashes. This will maximize the battery life.
- The battery cannot be overcharged.



Selecting the Dialing Mode

You can program the dialing mode using the handset near the base unit.

If you have touch tone service, set to "Tone". If rotary or pulse service is used, set to "Pulse". Your phone comes from the factory set to "Tone".

Make sure the unit is in the standby mode initially.

- 1 Press **FUNCTION/CH**.

▶Save directory
Ringer volume
▼▲ ▶=Yes
- 2 Press **▼** or **▲** repeatedly until the arrow points to "Program".

▶Program
▼▲ ▶=Yes
- 3 Press **▶** (Yes key).

▶Save DIRECT#
Set flash time
▼▲ ▶=Yes
- 4 Press **▼** or **▲** repeatedly until the arrow points to "Set dial mode".

▶Set dial mode
▼▲ ▶=Yes
- 5 Press **▶** (Yes key).

Dial mode
:Tone
▼▲ ▶=Save
- 6 Press **▼** or **▲** to select "Pulse" or "Tone".

Dial mode
:Pulse
▼▲ ▶=Save
- 7 Press **▶** (Save key).

Dial mode
:Pulse

 - A beep sounds.
 - To return to the standby mode, press **OFF**.

- You can exit the programming mode any time by pressing **OFF**.
- If the handset has lost communication with the base unit, 3 beeps sound and "No link to base. Place on cradle and try again." is displayed.

Selecting the Line Mode

If the line is connected to a low voltage system such as a PBX, set to "B". Otherwise the Call Waiting Caller ID Feature may not be used (p. 50). Your phone comes from the factory set to "A".

Use the handset near the base unit.

Make sure the unit is in the standby mode initially.

1 Press **FUNCTION/CH**.

```
▶Save directory
  Ringer volume
▼▲                ▶=Yes
```

2 Press **▼** or **▲** repeatedly until the arrow points to "Program".

```
▶Program
▼▲                ▶=Yes
```

3 Press **▶** (Yes key).

```
▶Save DIRECT#
  Set flash time
▼▲                ▶=Yes
```

4 Press **▼** or **▲** repeatedly until the arrow points to "Set line mode".

```
▶Set line mode
  Talk switching
▼▲                ▶=Yes
```

5 Press **▶** (Yes key).

```
Line mode
                               :A
▼▲                ▶=Save
```

6 Press **▼** or **▲** to select "B" or "A".

```
Line mode
                               :B
▼▲                ▶=Save
```

7 Press **▶** (Save key).

- A beep sounds.
- To return to the standby mode, press **OFF**.

```
Line mode
                               :B
```

- You can exit the programming mode any time by pressing **OFF**.
- If the handset has lost communication with the base unit, 3 beeps sound and "No link to base. Place on cradle and try again." is displayed.

Programmable Functions



You can program the following function items **using the handset near the base unit**. The display shows the programming instructions. See the corresponding pages for function details.

Make sure the unit is in the standby mode initially.

Press **FUNCTION/CH**.



<Function menu>*

- ▶ Save directory
- Ringer volume
- Program

To store an item in the directory (p. 36).

To select the ringer volume (p. 17).



Press **▶**.

<Function menu>*

- ▶ Save DIRECT#
- Set flash time
- Save mailbox#
- Voicemail tone
- Set line mode
- Talk switching
- Set dial mode

To store a phone number in the DIRECT button (p. 34).

To select the flash time (p. 51).

To store a voice mail access number (p. 46).

To set the voice mail tone (p. 47).

To select the line mode (p. 14).

To set the auto talk feature (p. 16).

To select the dial mode (p. 13).



During programming:

*To select a desired function item, press **▼** or **▲** repeatedly until the arrow points to the item. Then press **▶** to go to the next step.

- You can exit the programming mode any time by pressing **OFF**.
- If you do not press any buttons for 60 seconds, the unit will return to the standby mode.
- If the handset has lost communication with the base unit, 3 beeps sound and "No link to base. Place on cradle and try again." is displayed.



➔ Programmable Functions

Setting the Auto Talk Feature

The Auto Talk feature allows you to answer a call by lifting the handset of the base unit without pressing  or . If you want to use this feature, turn the feature ON by programming. Your phone comes from the factory set to OFF.



Make sure the unit is in the standby mode initially.

1 Press **FUNCTION/CH**.

2 Press  or  repeatedly until the arrow points to "Program".

```
▶Program
▼▲                               ▶=Yes
```



3 Press  (Yes key).

4 Press  or  repeatedly until the arrow points to "Talk switching".

```
Set line mode
▶Talk switching
▼▲                               ▶=Yes
```

5 Press  (Yes key).

```
Auto talk
:Off
▼▲                               ▶=Save
```

6 Press  or  to select "On" or "Off".

```
Auto talk
:On
▼▲                               ▶=Save
```

7 Press  (Save key).

- A beep sounds.

- To return to the standby mode, press **OFF**.

```
Auto talk
:On
```

- You can exit the programming mode any time by pressing **OFF**.

- In order to view Caller ID information before answering a call, leave the Auto Talk feature OFF.

Selecting the Ringer Volume

You can set the handset and base unit ringer volumes to HIGH, LOW or OFF. If set to OFF, the handset/base unit will not ring.

Handset ringer volume

Make sure the unit is in the standby mode initially.

- 1 Press **FUNCTION/CH**.
- 2 Press **▼** or **▲** repeatedly until the arrow points to "Ringer volume", and press **►** (Yes key).
- 3 Press **▼** or **▲** to select the desired volume.
 - The selected volume is displayed and rings.
 - To turn the ringer OFF, press and hold **▼** until 2 beeps sound.

To turn the ringer ON, press **▲** or **▼** in step 3.

- The ringer will sound at the LOW level.
- You can also select the ringer volume while a call is being received. Press **▼** or **▲** while the unit is ringing.
- When set to OFF, "Ringer off" will flash for about 45 seconds before the handset returns to the standby mode.

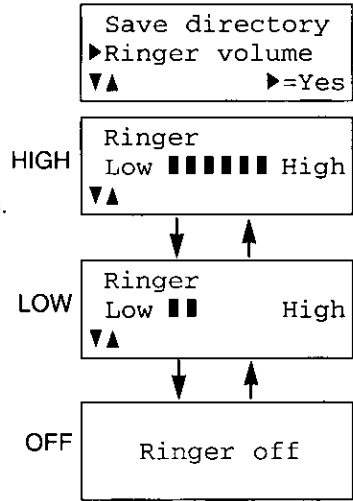

Base unit ringer volume

Make sure the unit is in the standby mode initially. (You can also select the ringer volume while a call is being received.)

- To select HIGH or LOW, press **HOLD/RINGER**. Each time you press the button, the selected ringer volume will be displayed and ring.
- To turn the ringer OFF, press and hold **HOLD/RINGER** until 2 beeps sound. "Ringer off" will be displayed.
- To turn the ringer ON, press **HOLD/RINGER**. The ringer will sound at the HIGH level.

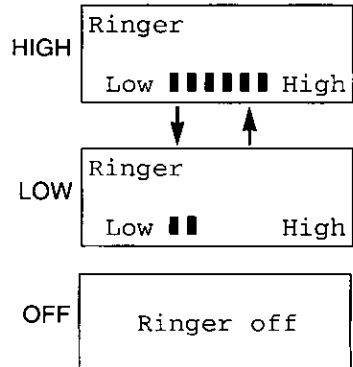

Making Calls

With the Handset

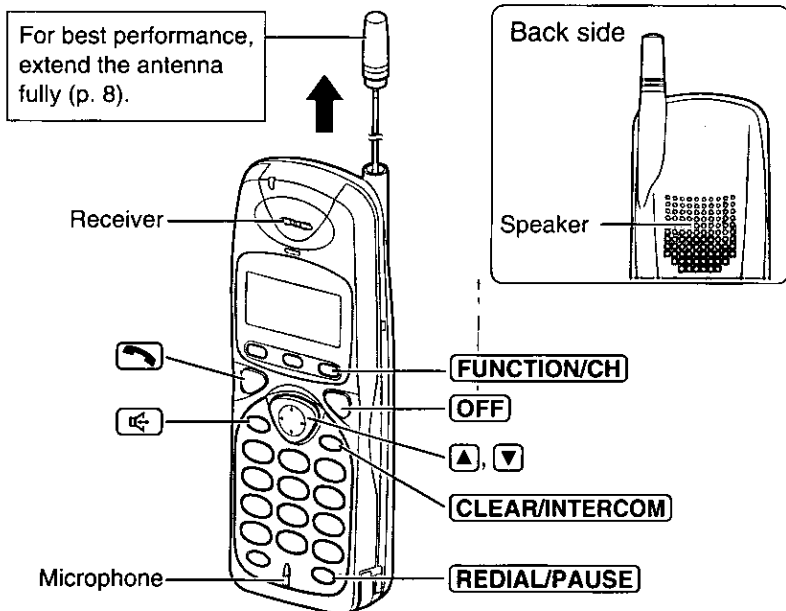

1 Press .

Talk

2 Dial a phone number.
•The dialed number is displayed.
•After a few seconds, the display will show the length of the call and the battery strength.

Talk
1112222

Talk
00-00-00 {■■■■}

3 To hang up, press **OFF** or place the handset on the base unit.

Off
00-01-20 {■■■■}

•If the handset has lost communication with the base unit, 3 beeps sound and "No link to base. Place on cradle and try again." is displayed.



To have a hands-free phone conversation (Using Digital Duplex Speakerphone)

- 1 Press .
 - The button lights.
- 2 Dial a phone number.
 - The dialed number is displayed.
 - After a few seconds, the display will show the length of the call and the battery strength.
- 3 When the other party answers, talk into the microphone.
- 4 To hang up, press **OFF** or place the handset on the base unit.
 - The button light goes out.

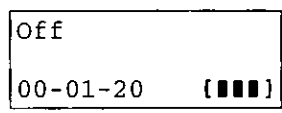
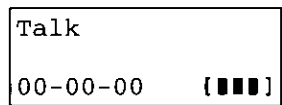
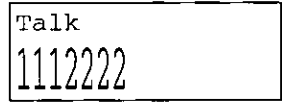
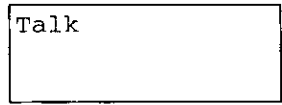

•If the handset has lost communication with the base unit, 3 beeps sound and "No link to base. Place on cradle and try again." is displayed.

Basic Operation

Hands-free Digital Duplex Speakerphone
 For best performance, please note the following:

- Talk alternately with the caller in a quiet room.
- If the other party has difficulty hearing you, press to decrease the speaker volume.
- If the other party's voice from the speaker cuts in/out during a conversation, press to decrease the speaker volume.
- While talking using , you can switch to the hands-free phone conversation by pressing . To switch back to the receiver, press .

To adjust the receiver volume (High, Medium or Low) or speaker volume (6 levels) while talking

- To increase, press .
- To decrease press .
- Each time you press or , the volume level will change.
 - The display will return to the length of the call.

Ex. Receiver volume: High
 Speaker volume: level 6

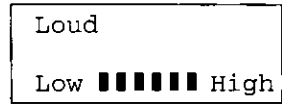

➔ Making Calls

If noise interferes with the conversation

Extend the antenna fully, press **FUNCTION/CH** to select a clearer channel or move closer to the base unit.



To redial the last number dialed on the handset

Press  or  and press **REDIAL/PAUSE**.

To dial after confirming the entered number

- 1** Dial a phone number.
•If you misdial, press **CLEAR/INTERCOM** and dial again.

33344444

- 2** Press .
OR
To have a hands-free phone conversation, press , and when the other party answers talk into the microphone.

Talk
33344444

- After a few seconds, the display will show the length of the call and the battery strength.

Talk
00-00-00 [■■■■]

- 3** To hang up, press **OFF** or place the handset on the base unit.

To redial after confirming the last number dialed

Press **REDIAL/PAUSE** and press  or .

Lighted handset keypad

The handset dialing buttons will light when you press a button or lift the handset off the base unit, and flash when a call is received. The lights will go out about 10 seconds after pressing a button, lifting the handset or answering a call.



With the Base Unit (Digital Duplex Speakerphone)

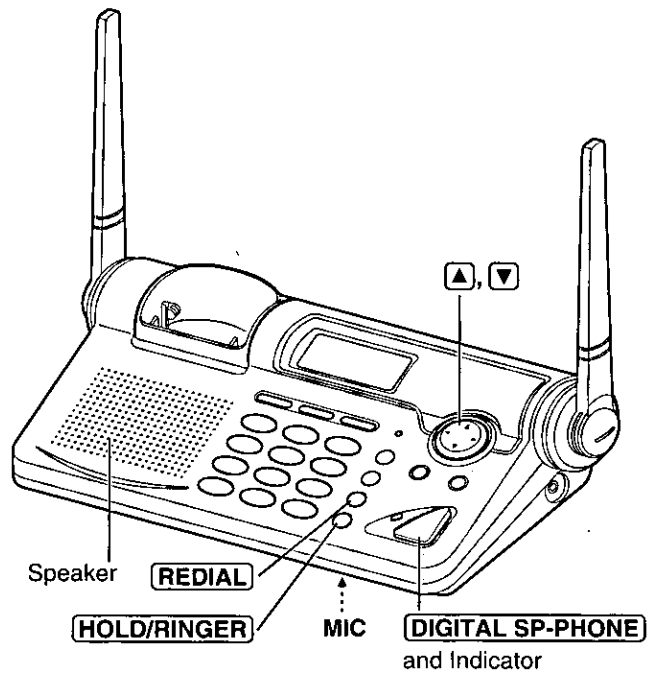

Basic Operation

1 Press **DIGITAL SP-PHONE**.
•The DIGITAL SP-PHONE indicator lights.

Talk

2 Dial a telephone number.

Talk
1112222

3 When the other party answers, talk into the **MIC** (microphone).

Talk
00-00-00

4 To hang up, press **DIGITAL SP-PHONE**.
•The indicator light goes out.



Off
00-02-10

- To switch to the handset while using the base unit speakerphone:
 - If the handset is off the base unit, press or .
 - If on the base unit, just lift up.
- During a call using the handset, the call can be switched to the base unit speakerphone by pressing **DIGITAL SP-PHONE** on the base unit.

➔ Making Calls

Hands-free Digital Duplex Speakerphone

For best performance, please note the following:

- Talk alternately with the caller in a quiet room.
- If the other party has difficulty hearing you, press  to decrease the speaker volume.
- If the other party's voice from the speaker cuts in/out during a conversation, press  to decrease the speaker volume.

To adjust the speaker volume (8 levels) while talking

To increase, press .

To decrease, press .

Ex. Level 8

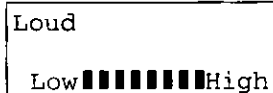

To redial the last number dialed on the base unit

Press  and press .

To put a call on hold



Press .

- The DIGITAL SP-PHONE indicator flashes.



To release the hold

From the base unit, press .

From the handset, press  or , or lift the handset off the base unit.

- If another phone is connected on the same line (p. 55), you can also release the hold by lifting its handset.

Simultaneous Keypad Dialing

You can use the base unit like a standard telephone. After pressing  to make a call with the handset near the base unit, you can also dial using the base unit keypad.

- 1 Handset:
Press .
- 2 Base unit:
Dial a telephone number while hearing a dial tone on the handset.
 - When the other party answers, talk using the handset.
- 3 Handset:
To hang up, press **OFF** or place the handset on the base unit.

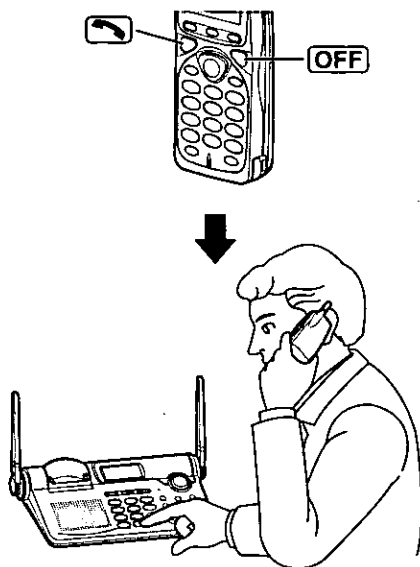

Simultaneous Keypad Dialing is possible after pressing .

Useful information

You can enter numbers using the base unit keypad during a call with the handset. For example, to access an answering service, electronic banking service, etc.

1. Handset:
Press .
2. Handset:
Dial a telephone number.
 - You can also dial with the base unit keypad.
3. Base unit:
Enter the required numbers while listening to the pre-recorded instructions.
4. Handset:
To hang up, press **OFF** or place the handset on the base unit.

Answering Calls

When a call is received, the unit rings, "Incoming call" is displayed and the ringer/charge indicator flashes.

If you subscribe to a Caller ID service, the calling party information will be displayed after the first ring (p. 26). In order to view the Caller ID information, please wait until the second ring to answer a call.

With the Handset

If the handset is off the base unit;



Press .

•You can also answer a call by pressing any dialing button **0** to **9**, ***** or **#** (**—Any Key Talk**).

OR

Press , and when the other party answers talk into the microphone.

Auto Talk

If you set the Auto Talk feature to ON (p. 16), you can answer a call by lifting the handset off the base unit without pressing  or .

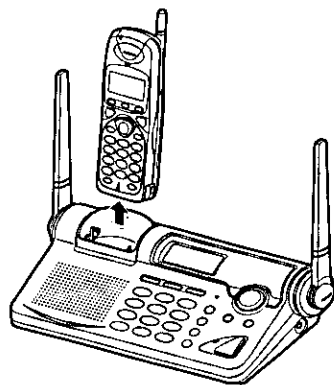
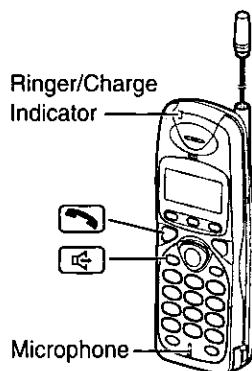

With the Base Unit

1 Press **DIGITAL SP-PHONE**.

2 Talk into the **MIC**.

3 To hang up, press **DIGITAL SP-PHONE**.

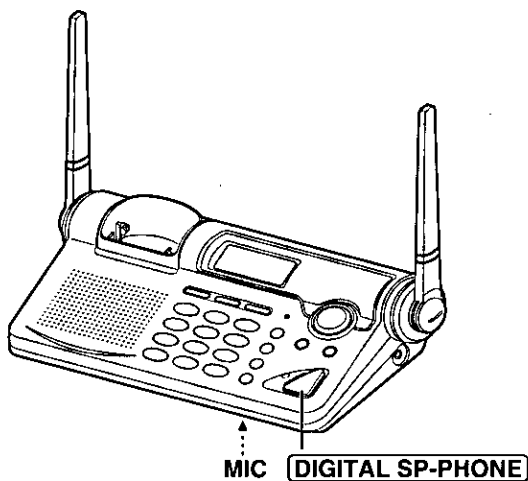

Caller ID Service

This unit is compatible with a Caller ID service offered by your telephone company. If you subscribe to a Caller ID service, the calling party's information will be shown on the handset and base unit displays after the first ring.

The unit can record information of up to 50 different callers in the Caller List. The Caller List information is sorted by the most recent to the oldest call. When the 51st call is received, the first call is deleted.

Using the list, you can automatically call back a caller. You can store the callers' names and numbers from the Caller List into the directory.

If you subscribe to both Caller ID and Call Waiting services, when a second call is received while talking, the new caller's name and phone number will be displayed (p. 50).

How caller information is displayed when a call is received

The handset and base unit displays show the caller's name and number after the first ring.

- After you answer the call, the display will show the length of the call.



- Caller information cannot be displayed in the following cases:
 - If the caller dialed from an area which does not provide a Caller ID service, the display will show "Out of area".
 - If the caller has requested not to display his/her information, the display will show "Private caller".
- If your unit is connected to a PBX which does not support Caller ID services, you cannot access those services.
- The name display service may not be available in some areas. For further information, please contact your telephone company.

Call group feature (Dual-Color Visual Ringer):

If you receive a caller ID call from one of the phone numbers stored in the directory and the item has set the feature;

- the handset and base unit will ring with a different ringer pattern,
- the handset and base unit displays will light in orange, and
- the ringer/charge indicator will flash in orange.

You can then distinguish the caller from others easily. To use this feature, store items in the directory and turn the feature on for required items (p. 32, 35, 36).

To check the number of new calls

When new calls have been received, the CALLER ID indicator flashes on the base unit. The handset and base unit displays show the number of new calls.

Ex. You have received 10 new calls.

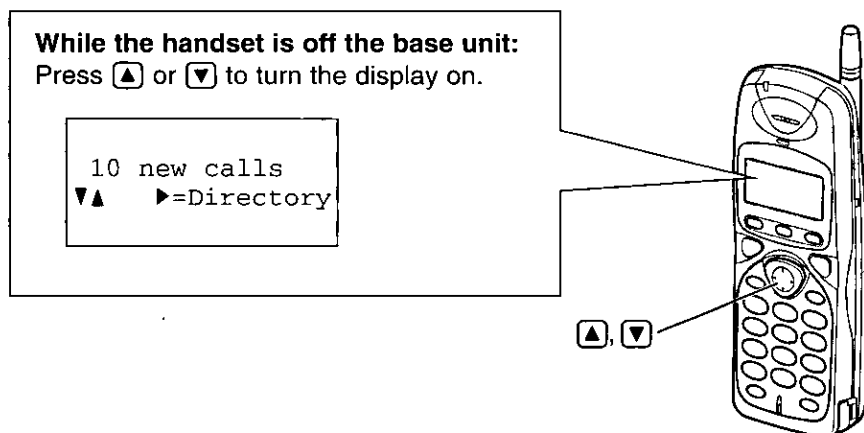
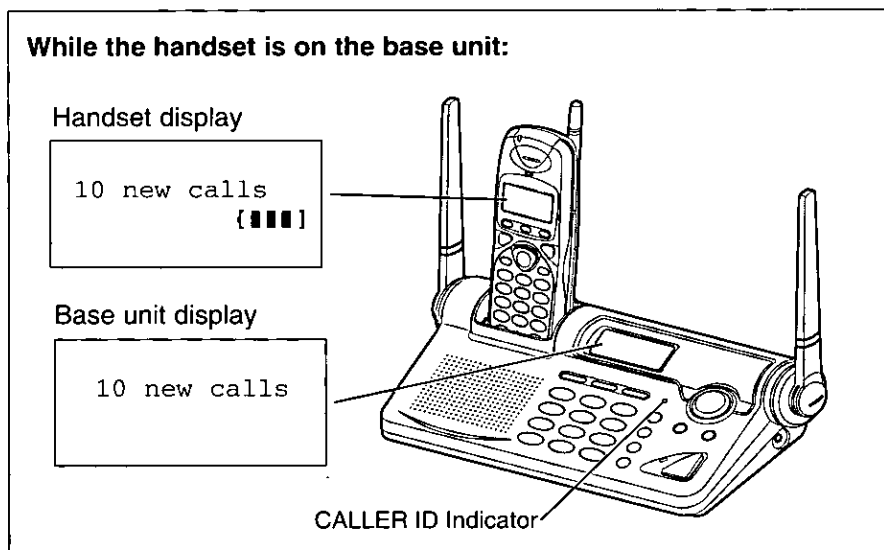

•If "No items stored" is displayed, the Caller List is empty.



Using the Caller List

Viewing the Caller List

You can view the caller list with the handset or the base unit. Caller List information includes the caller's name and phone number, the time and date the call was received, and the number of times that caller called.

Make sure the unit is in the standby mode initially.



With the handset



1 Press  or  to enter the Caller List.

- The display will show, for example, the following.

```
2 new calls
▼▲ ▶=Directory
```

- You can go to the directory list by pressing  (p. 40).

2 To search from the most recent call, press .
To search from the oldest call, press .



- To scroll between callers, press  or .

```
JACK SMITH
1-222-333-4444
3:10P JUN.10
```

3 To exit the list, press **OFF**.

- The handset will return to the standby mode.



With the base unit



1 Press  or  to enter the Caller List.

- The display will show, for example, the following.

```
2 new calls
▼▲ ▶=Directory
```

- You can go to the directory list by pressing  (p. 40).

2 To search from the most recent call, press .
To search from the oldest call, press .

- To scroll between callers, press  or .

```
JACK SMITH
1-222-333-4444
3:10P JUN.10
```

3 To exit the list, press **EXIT**.

- The base unit will return to the standby mode.

- If "No items stored" is displayed, the Caller List is empty.
- If there is no name information for a caller, the display will only show the phone number.
- While you are viewing the Caller List with the handset, another person cannot access the list using the base unit, and vice versa.



What “√” means

When the display shows “√”, you have already viewed this calling information, answered the call or called back the caller. If the same caller calls again, the call entry with “√” will be replaced with the new call entry.

```
JACK SMITH
1-222-333-4444
3:10P JUN.10 √
```

If a caller calls more than once

The number of times the same caller called is displayed (X2 to X9). The date and time of the most recent call will be recorded. After checking, X2 to X9 will be replaced with “√”.

```
JACK SMITH
1-222-333-4444
3:10P JUN.10 X3
```

Calling Back from the Caller List

With the handset

- 1 Press or to enter the Caller List.

```
3 new calls
▼▲ ▶=Directory
```

- 2 To search from the most recent call, press . To search from the oldest call, press .

```
CINDY TURNER
1-234-456-7890
11:20A JAN.12 X3
```

- 3 Press or . •The displayed phone number is dialed automatically.

```
Talk
12344567890
```

With the base unit

- 1 Press or to enter the Caller List.

```
3 new calls
▼▲ ▶=Directory
```

- 2 To search from the most recent call, press . To search from the oldest call, press .

```
CINDY TURNER
1-234-456-7890
11:20A JAN.12 X3
```

- 3 Press **DIGITAL SP-PHONE**. •The displayed phone number is dialed automatically.

```
Talk
12344567890
```

- In some cases, you may have to edit the number before dialing (p. 30, 31). (Ex. You may have to delete “1” and the area code.)
- If a phone number is not displayed in the caller information, you cannot call back that caller.

➔ Using the Caller List

Editing the Caller's Phone Number

You can edit a phone number into one of 4 patterns using the handset or the base unit.

Make sure the unit is in the standby mode initially.

With the handset

1 Press or to enter the Caller List.

5 new calls
▼▲ ▶=Directory

2 Press or repeatedly to find the desired caller, and press .

FRED PARKER
1-234-321-5555
11:20A JAN.12 ✓

▶Edit
Save directory
▼▲ ▶=Yes

3 While the arrow points to "Edit", press (Yes key).

FRED PARKER
1-234-321-5555
▼=Next ▶=Edit

4 Press (Edit key) to select a pattern.

- Each time you press , the number is rearranged into one of 4 different patterns.

Ⓐ

Ⓑ -

Ⓒ 1 -

Ⓓ 1 - -

- The order in which patterns Ⓐ-Ⓓ are displayed depends on how the telephone number is displayed in step 3.

Ⓐ 321-5555
▼=Next ▶=Edit

Ⓑ 234-321-5555
▼=Next ▶=Edit

Ⓒ 1-321-5555
▼=Next ▶=Edit

Ⓓ 1-234-321-5555
▼=Next ▶=Edit

5 After editing the number, you can continue with calling back or storing procedures. To call back, press or (p. 29). To store the number in the directory, press (Next key), and follow the instructions on the display (see page 32).

- The number edited in step 4 will not be maintained in the Caller List.



With the base unit

1 Press \blacktriangledown or \blacktriangle to enter the Caller List.

2 Press \blacktriangledown or \blacktriangle repeatedly to find the desired caller.

3 Press **EDIT** to select a pattern.

- Each time you press **EDIT**, the number is rearranged into one of 4 different patterns.

- (a) .
- (b) - .
- (c) 1 - .
- (d) 1 - - .

- The order in which patterns (a)–(d) are displayed depends on how the telephone number is displayed in step 2.

4 After editing the number, you can continue with calling back. Press **DIGITAL SP-PHONE** (p. 29).

- The number edited in step 3 will not be maintained in the Caller List.

```

5 new calls
▼▲ ▶=Directory
  
```

```

FRED PARKER
1-234-321-5555
11:20A JAN.12 ✓
  
```

(a) FRED PARKER
321-5555

(b) FRED PARKER
234-321-5555

(c) FRED PARKER
1-321-5555

(d) FRED PARKER
1-234-321-5555



➔ Using the Caller List

Storing Caller List Information in the Directory



You can store names and phone numbers that are in the Caller List into the directory. You can also turn the call group feature on for certain callers (p. 35).

Storing must be carried out with the handset.

Make sure the unit is in the standby mode initially.

1 Press  or  to enter the Caller List.



```
10 new calls
▼▲ ▶=Directory
```

2 Press  or  repeatedly to find the caller you want to store in the directory, and press  (Yes key).

```
CINDY TURNER
1-234-456-7890
11:20A JAN.12 X3
```

•If the number requires editing, see page 30.

```
▶Edit
Save directory
▼▲ ▶=Yes
```

3 Press  or  to select "Save directory", and press  (Yes key).

```
Edit
▶Save directory
▼▲ ▶=Yes
```



If there is no name information for the caller, "Enter name" will be displayed.

a) If a name is not required, press  (Next key) twice.

```
Enter name
□
◀▶ ▼=Next

```

b) If a name is required, enter the name (p. 38). When finished, press  (Next key) twice.

```
Enter name
CINDY TURNER
◀▶ ▼=Next

```

4 To turn the call group feature on, select "On" by pressing  or . If not required, select "Off". (See page 37, from step 7.)

```
Set group
:Off
◀▶ ▼=Next

```

- You can exit the programming mode any time by pressing **OFF**.
- If the display shows "Directory full" in step 3, press **OFF** to exit the list. To erase other stored items from the directory, see page 43.
- You cannot store caller information in the directory if a phone number is not displayed.
- If 3 beeps sound and the display shows "Save error", move closer to the base unit and start again from step 1.

Erasing Caller List Information

After checking the Caller List, you can erase some or all of the entries with the handset or the base unit.

Make sure the unit is in the standby mode initially.

To erase a specific caller from the Caller List

With the handset/base unit:

- 1 Press **▼** or **▲** to enter the Caller List.

```
10 new calls
▼▲ ▶=Directory
```

- 2 Press **▼** or **▲** repeatedly to find the caller you want to erase from the Caller List.

```
TOM REAGAN
1-888-777-6666
12:20A JAN.12 ✓
```

- 3 If using the handset, press **CLEAR/INTERCOM**.
OR
If using the base unit, press **CLEAR**.

```
Clear
```

- A beep sounds and the information is erased.
- To erase other items, repeat from step 2.
- To return to the standby mode, if using the handset, press **OFF**.
If using the base unit, press **EXIT**.

To erase all entries in the Caller List

Before erasing all entries, make sure that "0 new call" is displayed.

With the handset/base unit:

- 1 Press **▼** or **▲** to enter the Caller List.

```
0 new call
▼▲ ▶=Directory
```

- 2 If using the handset, press **CLEAR/INTERCOM**.
OR
If using the base unit, press **CLEAR**.

```
▶Exit
All clear
▼▲ ▶=Yes
```

- 3 Press **▼** or **▲** to select "All clear".

```
Exit
▶All clear
▼▲ ▶=Yes
```

- 4 Press **▶** (Yes key).

```
All clear
```

- A beep sounds and all entries are erased.

One-Touch Dialer

You can store a phone number in the **DIRECT** button of the handset. The stored number is dialed with a one-touch operation.

Storing a Phone Number in the DIRECT Button

Make sure the unit is in the standby mode initially.

1 Press **FUNCTION/CH**.

2 Press **▼** or **▲** repeatedly until the arrow points to "Program".

▶Program
▼▲ ▶=Yes

3 Press **▶** (Yes key).

▶Save DIRECT# Set flash time
▼▲ ▶=Yes

4 While the arrow points to "Save DIRECT#", press **▶** (Yes key).

□
◀▶ ▼=Next

5 Enter a phone number, up to 22 digits.

- Each time you press **CLEAR/INTERCOM** the digit to the left of the cursor is erased. To erase all digits, press and hold **CLEAR/INTERCOM**.
- To move the cursor, press **◀** or **▶**.

1234567890123456 789012
◀▶ ▼=Next

6 Press **▼** (Next key).

- If you want to edit the entered number, press **▲** (Edit key) and return to step 5.

1234567890123456 789012
▲=Edit ▶=Save

7 Press **▶** (Save key).

- A beep sounds.
- To return to the standby mode, press **OFF**.

1234567890123456 789012 Save DIRECT#
--



- You can exit the programming mode any time by pressing **OFF**.
- If a pause is required for dialing, **REDIAL/PAUSE** can be stored in a phone number in step 5. This counts as one digit (p. 49).

Dialing the Stored Number in the DIRECT Button

- 1 Press **DIRECT**.
- The stored number is displayed.

1234567890123456 789012

- 2 Press  or .
- The number is dialed.

- You can also dial the stored number by pressing  or  then pressing **DIRECT**.
- If your line has rotary or pulse service, any access numbers stored after pressing **TONE** will not be dialed.

Using the Directory

You can store up to 90 names and phone numbers in the directory using the handset. All directory items are sorted by the first word in alphabetical order. Using the directory, you can make a call by selecting a name on the handset or base unit display.

Call group feature (Dual-Color Visual Ringer):

You can distinguish certain callers from others by the ringer pattern, the color of the display backlight and the ringer charge indicator light when a call is received. Turn the call group feature on for required items (for example, for family). When a Caller ID call is received from those callers, the handset and the base unit will ring with a different ringer pattern from the 2nd or 3rd ring, the handset and base unit displays will light in orange and the ringer/charge indicator will flash in orange from the 2nd or 3rd ring.

Call group feature	Backlight color Ringer/Charge indicator light color	Ringer pattern
Off	Green	Ordinary
On	Orange	Higher pitch

- The call group feature cannot be used without subscribing to a Caller ID service (p. 26).

➔ Using the Directory

Storing Names and Numbers in the Directory

Store a name and number, then if required, turn the call group feature on for the item.

Storing must be carried out with the handset.

Make sure the unit is in the standby mode initially.

1 Press **FUNCTION/CH**.

▶Save directory
Ringer volume
▼▲ ▶=Yes

2 While the arrow points to "Save directory", press **▶** (Yes key).

- The display shows the number of stored items in the directory.

Directory=
20 items



3 Enter a name, up to 15 characters using the dialing buttons (p. 38).

- To move the cursor, press **◀** or **▶**.
- If a name is not required, press **▼** (Next key) and go to step 5.

Enter name
□
◀▶ ▼=Next



Enter name
Tom Jones
◀▶ ▼=Next

4 Press **▼** (Next key).

Enter phone no.

5 Enter a phone number, up to 22 digits.

- If you misdial, press **CLEAR/INTERCOM**. Digits are erased from the right. To erase all digits, press and hold **CLEAR/INTERCOM**.

0987654321□
◀▶ ▼=Next

6 Press **▼** (Next key).

Set group
:Off
◀▶ ▼=Next



- 7 To turn the call group feature on, select "On" by pressing ◀ or ▶.
If not required, select "Off".

- When "On" is selected, the display will light in orange and a different ringer pattern will be heard. When "Off" is selected, an ordinary ringer pattern will be heard.

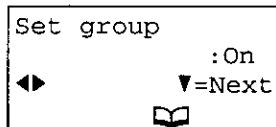

- 8 Press ▼ (Next key).

- If you want to change the storing name, number or group setting, press ▲ (Edit key) repeatedly to reach the desired display and change it.

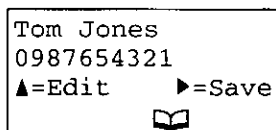

- 9 Press ▶ (Save key).

- A beep sounds.
- To continue storing other items, repeat from step 2.
- To return to the standby mode, press **OFF**.

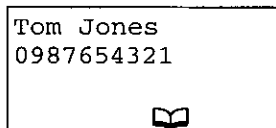

- If a pause is required for dialing, **REDIAL/PAUSE** can be stored in a phone number in step 5. This counts as one digit (p. 49).
- You can exit the programming mode any time by pressing **OFF**.
- If the display shows "Directory full" in step 2, press **OFF**. To erase other stored items from the directory, see page 43.
- After the maximum of 90 items has been stored, "Directory full" is also displayed.
- If 3 beeps sound and the display shows "Save error", move closer to the base unit and start again from step 1.

➔ Using the Directory

Selecting Characters to Enter Names

The handset dialing buttons (0) to (9) can be used to enter letters and symbols. The letters are printed on the dialing buttons.

Pressing each button selects a character as shown below.

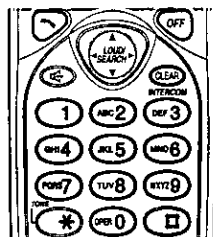

Keys	Number of times key is pressed										
	1	2	3	4	5	6	7	8	9	10	11
1	#	&	'	()	*	,	-	.	/	1	
2	A	B	C	a	b	c	2				
3	D	E	F	d	e	f	3				
4	G	H	I	g	h	i	4				
5	J	K	L	j	k	l	5				
6	M	N	O	m	n	o	6				
7	P	Q	R	S	p	q	r	s	7		
8	T	U	V	t	u	v	8				
9	W	X	Y	Z	w	x	y	z	9		
0	0	Blank									
◀	To move the cursor to the left										
▶	To move the cursor to the right										

• To enter another character using the same dialing button, press ▶ to move the cursor to the next space.

If you make a mistake while entering a name

Use ◀ or ▶ to move the cursor to the incorrect character, press **CLEAR/INTERCOM** to delete and enter the correct character. Each time you press **CLEAR/INTERCOM**, a character is erased from the right. To erase all characters, press and hold **CLEAR/INTERCOM**.



For example, to enter "Tom Jones":

- 1 Press **FUNCTION/CH**.
- 2 While the arrow points to "Save directory", press **▶** (Yes key).
- 3 Press **8**.
- 4 Press **6** six times, then press **▶** to move the cursor to the right.
- 5 Press **6** four times.
- 6 Press **▶** twice to enter a blank.
- 7 Press **5**.
- 8 Press **6** six times, then press **▶** to move the cursor to the right.
- 9 Press **6** five times.
- 10 Press **3** five times.
- 11 Press **7** eight times.
- 12 When finished, press **▼** (Next key).
 - To enter a phone number and continue storing, see page 36, from step 5.

▶Save directory
Ringer volume
▼▲ ▶=Yes

Directory=
20 items

Enter name
□
◀▶ ▼=Next

□

To□

Tom

Tom □

Tom Jj

Tom Jo□

Tom Jon

Tom Jonē

Enter name
Tom Jones
◀▶ ▼=Next

Enter phone no.

Advanced Operation

➔ Using the Directory

Finding Items in the Directory

You can search the directory using the handset or the base unit.
Make sure the unit is in the standby mode initially.

With the handset/base unit

1 Press ◀ or ▶ to enter the directory list.

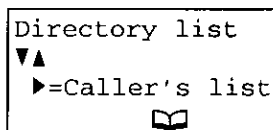

2 Press ▼ or ▲.
•The first item is displayed.

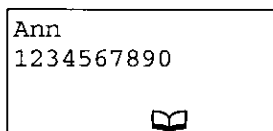

3 Press ▼ or ▲ repeatedly until the desired item is displayed
•All directory items are stored in the order shown on the right.

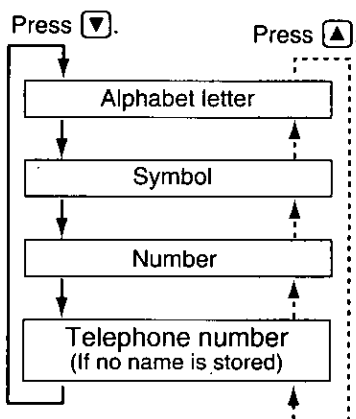

To search for a name by initial

With the handset/base unit:

1 Press ◀ or ▶ to enter the directory list.

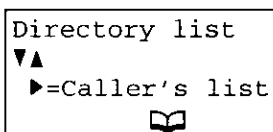

2 Press ▼ or ▲.
•The first item is displayed.

3 Press the dialing button for the first letter of the desired name until any name with the same initial is displayed (see the Index table on page 41).

Ex. To find "Frank", press 3 repeatedly until the first item under "F" is displayed.

4 Press ▼ repeatedly until the name is displayed.



Index table

Keys	Index	Keys	Index
1	Other symbols, 1	6	M, N, O, 6
2	A, B, C, 2	7	P, Q, R, S, 7
3	D, E, F, 3	8	T, U, V, 8
4	G, H, I, 4	9	W, X, Y, Z, 9
5	J, K, L, 5	0	0

- You can leave the directory list any time. If using the handset, press **OFF**. If using the base unit, press **EXIT**.
- If "No items stored" is displayed in step 2, the directory is empty.
- In step 1, you can go to the Caller List by pressing (p. 28).
- If you are viewing the directory with the handset, another person cannot access the directory using the base unit, and vice versa.

Dialing from the Directory

Make sure the unit is in the standby mode initially.

With the handset

- 1 Press or to enter the directory list.

Directory list
 ▼▲
 ▶=Caller's list

- 2 Press or .
- The first item is displayed.
- 3 Press or repeatedly to find the directory item that you want to dial.
 - To search for the item by initial, see page 40.
 - To exit the directory, press **OFF**.

- 4 Press or .
- The number is dialed automatically.

With the base unit

- 1 Press or to enter the directory list.

Directory list
 ▼▲
 ▶=Caller's list

- 2 Press or .
- The first item is displayed.
- 3 Press or repeatedly to find the directory item that you want to dial.
 - To search for the item by initial, see page 40.
 - To exit the directory, press **EXIT**.

- 4 Press **DIGITAL SP-PHONE**.
- The number is dialed automatically.

➔ Using the Directory

Editing an Item in the Directory

You can edit a name and phone number of a stored item and change the group setting (p. 35).

Programming must be carried out with the handset.

Make sure the unit is in the standby mode initially.

1 Press **◀** or **▶** to enter the directory list.

```
Directory list
▼▲
▶=Caller's list
```

2 Press **▼** or **▲**.
•The first item is displayed.

```
Jane
1234567
```

3 Press **▼** or **▲** repeatedly to find the directory item you want to change, and press **▶**.
•To search for the item by initial, see page 40.
•If you do not need to change the name, go to step 5.

```
Enter name
Jane
◀▶           ▼=Next
```

4 Edit the name using the dialing buttons, **◀** or **▶** (p. 38), up to 15 characters.

```
Enter name
Jane Walke
◀▶           ▼=Next
```

5 Press **▼** (Next key).
•If you do not need to change the number, go to step 7.

```
1234567
◀▶           ▼=Next
```

6 Add a number to the current number.
•Pressing **CLEAR/INTERCOM** erases the digit to the left of the cursor. To erase all digits, press and hold **CLEAR/INTERCOM**.

```
0981234567
◀▶           ▼=Next
```

7 Press **▼** (Next key).

```
Set group           :Off
◀▶                 ▼=Next
```

8 To turn the call group feature on, select "On" by pressing **◀** or **▶**. If not required, select "Off".
•When "On" is selected, the display will light in orange and a different ringer pattern will be heard. When "Off" is selected, an ordinary ringer pattern will be heard.

```
Set group           :On
◀▶                 ▼=Next
```

9 Press **▼** (Next key).

- If you want to change the storing name, number or group setting, press **▲** (Edit key) repeatedly to reach the desired display and change it.

Jane Walker
0981234567
▲=Edit ▶=Save

10 Press **▶** (Save key).

- A beep sounds.
- To continue editing other items, repeat from step 3.
- To return to the standby mode, press **OFF**.

•You can exit the programming mode any time by pressing **OFF**.

Erasing an Item from the Directory

Make sure the unit is in the standby mode initially.

With the handset

- 1 Press **◀** or **▶** to enter the directory list.
- 2 Press **▼** or **▲**.
 - The first item is displayed.
- 3 Press **▼** or **▲** repeatedly to find the directory item you want to erase.
 - To search for the item by initial, see page 40.

Helen
1234567890

4 Press **CLEAR/INTERCOM**.

Clear?
◀=No ▶=Yes

- To stop erasing, press **◀** (No key).

5 Press **▶** (Yes key) or **CLEAR/INTERCOM**.

- A beep sounds and "Clear" is displayed.
- To erase other items, repeat from step 3.
- To return to the standby mode, press **OFF**.

With the base unit

- 1 Press **◀** or **▶** to enter the directory list.
- 2 Press **▼** or **▲**.
 - The first item is displayed.
- 3 Press **▼** or **▲** repeatedly to find the directory item you want to erase.
 - To search for the item by initial, see page 40.

Helen
1234567890

4 Press **CLEAR**.

Clear?
◀=No ▶=Yes

- To stop erasing, press **◀** (No key).

5 Press **▶** (Yes key) or **CLEAR**.

- A beep sounds and "Clear" is displayed.
- To erase other items, repeat from step 3.
- To return to the standby mode, press **EXIT**.

Intercom

A 2-way intercom is possible between the handset and the base unit.

Paging the base unit from the handset

- 1 Handset:
Press **CLEAR/INTERCOM**. Talk to the paged party after the beeps.

- “Intercom” is displayed.

- 2 Base unit:
When the other party’s voice is heard, answer using the **MIC**.

- 3 Handset:
To end the intercom, press **OFF**.

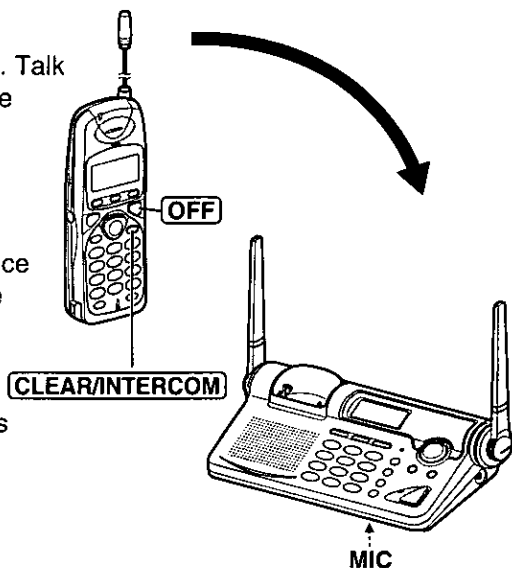

Paging the handset from the base unit (Handset locator)

Using this feature, you can locate a misplaced handset.

- 1 Base unit:
Press **LOCATOR/INTERCOM**.

- “Paging” is displayed on the base unit.
- The handset beeps for 1 minute and “Paging Press INTERCOM” is displayed.
- To stop paging, press **LOCATOR/INTERCOM** again.

- 2 Handset:
Press **CLEAR/INTERCOM** to answer.



- “Intercom” is displayed.

- 3 Base unit:
Talk into the **MIC**.

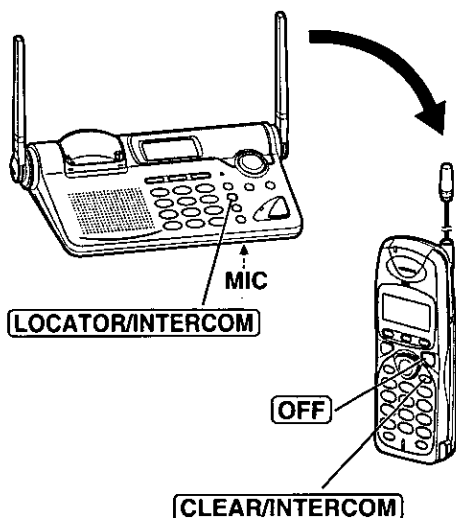
- 4 Handset:
To end the intercom, press **OFF**.





During an intercom call:

- Intercom calls can only be ended with the handset.
- If the handset user has difficulty hearing the base unit user, decrease the base unit speaker volume by pressing .
- If an incoming call is received, the intercom call stops and the unit starts to ring. To answer, if you are using the handset, press  or . If you are using the base unit, press **DIGITAL SP-PHONE**.



Transferring a Call Using the Intercom

The intercom can be used during a call. This feature enables you to transfer a call between the handset and the base unit.

From the handset to the base unit

- 1** Handset:
During a call, press **CLEAR/INTERCOM**. Talk to the paged party after the beeps.
 - The call is put on hold and "Intercom hold" is displayed.
 - If the base unit user does not answer, press  or .
- 2** Base unit:
When the paging party's voice is heard, answer using the **MIC**.
- 3** Base unit:
To answer the call, press **DIGITAL SP-PHONE**.
 - The transfer is complete.

From the base unit to the handset

- 1** Base unit:
During a call, press **LOCATOR/INTERCOM**.
 - The call is put on hold and "Paging" is displayed.
 - If the handset user does not answer, press **DIGITAL SP-PHONE**.
- 2** Handset:
Press **CLEAR/INTERCOM** to answer the page.
 - "Intercom hold" is displayed.
- 3** Handset:
To answer the call, press  or .
 - The transfer is complete.

Voice Mail Service

Voice mail service is an electronic on-line answering system offered by your telephone company. After subscribing, the voice mail system can answer calls automatically when your line is busy or if calls are not answered. Callers can leave messages by following the pre-recorded instructions. When voice mail messages are recorded, "Voicemail" and "☒" will be displayed and the VOICE MAIL button on the base unit will flash.

To use this feature, you must first store your access number.

Storing a Voice Mail Access Number

Make sure the unit is in the standby mode initially.

1 Press **FUNCTION/CH**.

2 Press **▼** or **▲** repeatedly until the arrow points to "Program".

▶Program
▼▲ ▶=Yes

3 Press **▶** (Yes key).

4 Press **▼** or **▲** repeatedly until the arrow points to "Save mailbox#".

▶Save mailbox# Voicemail tone
▼▲ ▶=Yes

5 Press **▶** (Yes key).

□
◀▶ ▼=Next

6 Enter your access number, up to 32 digits.

- If you enter a wrong number, press **CLEAR/INTERCOM**. Digits are erased from the right. To erase all digits, press and hold **CLEAR/INTERCOM**.

1234567890□
▼▲ ▶=Next

7 Press **▼** (Next key).

- If you want to edit the entered number, press **▲** (Edit key) and return to step 6.

1234567890
▲=Edit ▶=Save

8 Press **▶** (Save key).

- A beep sounds.
- To return to the standby mode, press **OFF**.

1234567890
Save mailbox#





To erase a stored number

Press and hold **CLEAR/INTERCOM** in step 6 on page 46.

•You can exit the programming mode any time by pressing **OFF**.

Setting the Voice Mail Tone

If your voice mail service sends a voice mail tone after a new message has been recorded, set to "On". "Voicemail" and "☒" will be displayed and the VOICE MAIL button on the base unit will flash when a message has been recorded in your mailbox. You will hear a series of voice mail tones followed by a dial tone after pressing ,  or **DIGITAL SP-PHONE**. (Contact your service provider for details about your service.)



Set to "Off" if:

- you do not subscribe to a voice mail service,
- your voice mail service does not send a voice mail tone, or
- the unit is connected to a PBX.

Your phone comes from the factory set to "On".



Make sure the unit is in the standby mode initially.

1 Press **FUNCTION/CH**.

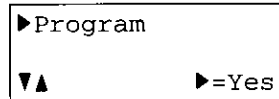
2 Press  or  repeatedly until the arrow points to "Program".





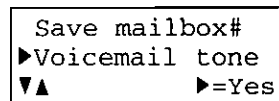

3 Press  (Yes key).

4 Press  or  repeatedly until the arrow points to "Voicemail tone".

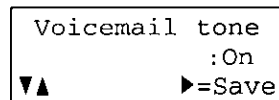

5 Press  (Yes key).



6 Press  or  to select "Off" or "On". Press  (Save key).

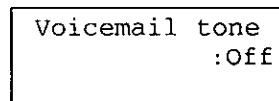



- A beep sounds.
- To return to the standby mode, press **OFF**.

•You can exit the programming mode any time by pressing **OFF**.

Listening to Voice Mail Messages

After receiving a voice mail message, "Voicemail" and "☒" will be displayed and the VOICE MAIL button on the base unit will flash. You can listen to your voice mail message(s) using the handset or the base unit.

With the handset

- 1 Press **VOICE MAIL**, and press  or .
- The unit is connected to the telephone line and dials the access number (p. 46).
- 2 Follow the pre-recorded instructions.
- 3 When finished, press **OFF**.

With the base unit

- 1 Press **VOICE MAIL**.
 - The unit is connected to the telephone line and automatically dials the access number (p. 46).
- 2 Follow the pre-recorded instructions.
- 3 When finished, press **DIGITAL SP-PHONE**.

- If "Voicemail" and "☒" still remain on the display and the VOICE MAIL button on the base unit still flashes even if you have listened to your voice mail message(s), press **FUNCTION/CH**, and press and hold **CLEAR/INTERCOM** on the handset until the unit beeps. "Voicemail" and "☒" will disappear and the button will go off.
- If your voice mail service uses a voice mail tone and the recorded message is over 3 minutes long, "Voicemail" and "☒" may not be displayed and the VOICE MAIL button may not flash.
- If your voice mail service uses a voice mail tone, the tone will be heard from any parallel connected phone. If you use another phone to retrieve messages, you have to dial your access number manually.

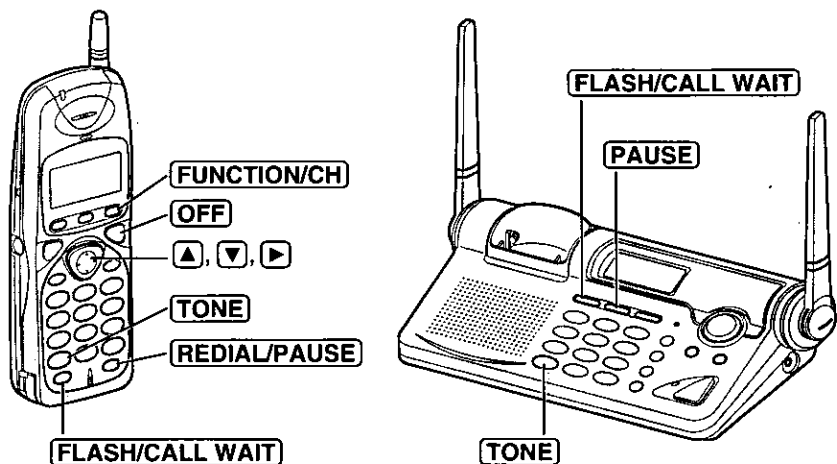

Automatic Security Code Setting

Each time you place the handset on the base unit, the unit automatically selects one of more than a million security codes. These codes help prevent the unauthorized use of your telephone line by another cordless telephone user.

How to Use the PAUSE Button

(For Analog PBX Line/Long Distance Service Users)

We recommend you press **REDIAL/PAUSE** or **PAUSE** if a pause is required for dialing with a PBX or to access a long distance service.

Ex. Line access number **9** (PBX)

9 → **REDIAL/PAUSE** or **PAUSE** → Phone number

- Pressing **REDIAL/PAUSE** or **PAUSE** once creates a 3.5 second pause. This prevents misdialing when you redial or dial a stored number.
- Pressing **REDIAL/PAUSE** or **PAUSE** more than once increases the length of the pause between numbers.

➔ Special Features

For Call Waiting Service Users

Press **FLASH/CALL WAIT** if you hear a call-waiting tone while talking.

- The first call is put on hold and you can answer the second call.
- To return to the first caller, press **FLASH/CALL WAIT** again.
- The call waiting service cannot be used when a parallel connected telephone is in use.
- If this function does not operate properly, consult your telephone company for details.

Call Waiting Caller ID Feature

Call Waiting Caller ID Feature allows your unit to display the second caller's information. After you hear a call-waiting tone while talking, the unit will display the caller's name with the phone number and "----waiting-----".

NANCY BROWN 1-000-222-3333 ----waiting-----

- Please contact your telephone company for details and availability in your area.

Temporary Tone Dialing (For Rotary or Pulse Service Users)

Press **TONE** before entering access numbers which require tone dialing.

- The dialing mode changes to tone. You can enter numbers to access an answering service, electronic banking service, etc. When you hang up, the mode will return to pulse.
- Access numbers entered after pressing **TONE** will not be included when redialing.

FLASH Button

Pressing **FLASH/CALL WAIT** allows you to use special features of your host PBX such as transferring an extension call or accessing special telephone services (optional) such as call waiting.

Selecting the flash time

The flash time depends on your telephone exchange or host PBX. You can select the following flash times: "700, 600, 400, 300, 250, 110, 100 or 90 ms (milliseconds)". Your phone comes from the factory set to "700 ms".

Make sure the unit is in the standby mode initially.

1 Press **FUNCTION/CH**.

2 Press **▼** or **▲** repeatedly until the arrow points to "Program".

```
▶Program
▼▲                                ▶=Yes
```

3 Press **▶** (Yes key).

4 Press **▼** or **▲** repeatedly until the arrow points to "Set flash time".

```
Save DIRECT#
▶Set flash time
▼▲                                ▶=Yes
```

5 Press **▶** (Yes key).

```
Flash time
: 700ms
▼▲                                ▶=Save
```

6 Press **▼** or **▲** repeatedly until the desired time is displayed, and press **▶** (Save key).

- A beep sounds.
- To return to the standby mode, press **OFF**.

•You can exit the programming mode any time by pressing **OFF**.

•If you are connected via a PBX, a longer flash time may be necessary to use PBX functions (transferring a call etc.). Consult your PBX supplier for the correct setting.

Wall Mounting

This unit can be mounted on a wall phone plate.

- 1 Connect the AC adaptor.

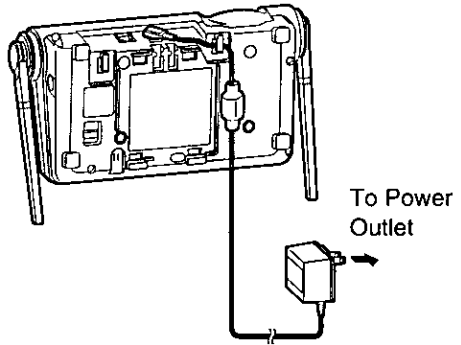

- 2 Tuck the telephone line cord inside the wall mounting adaptor, then push it in the direction of the arrow.
 - The word "UP" should face upward.

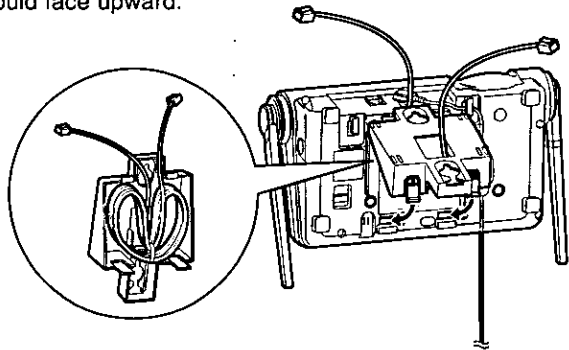

- 3 Connect the telephone line cord. Mount the unit, then slide down.
 - Raise the antennas.

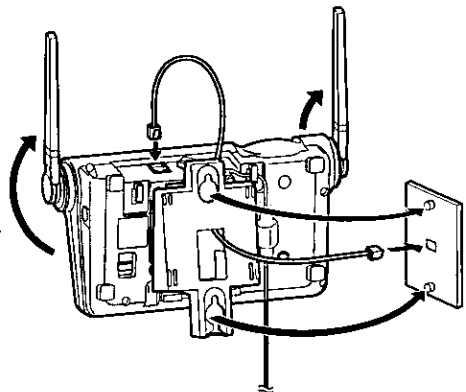

-
- 4 To charge the handset battery:**
Place the handset on the cradle and adjust the angle of the cradle in the direction of the arrow as shown.

- The ringer/charge indicator lights.

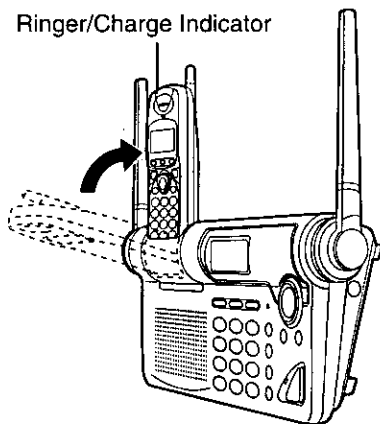

Using the Belt Clip

You can hang the handset on your belt or pocket using the belt clip.

To attach the belt clip

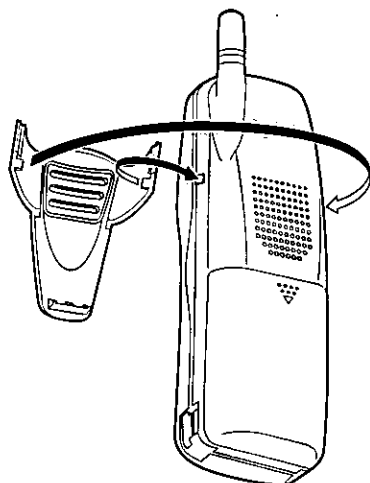

To remove the belt clip



Using an Optional Headset

Plugging an optional headset into the handset or the base unit allows a hands-free phone conversation. Please use only the Panasonic KX-TCA88 headset. To order call the accessories telephone number on page 2.



With the Handset

Connecting the headset to the handset

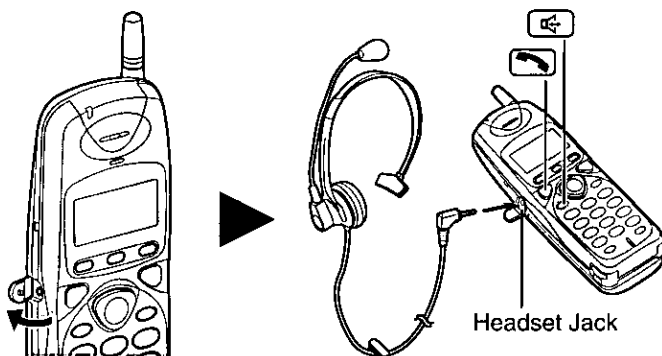
Open the headset jack cover, and connect the headset to the headset jack as shown.



To switch to the speakerphone while using the headset:

Press . To return to the headset, press .

With the Base Unit

Connecting the headset to the base unit

Connect the headset to the headset jack as shown.

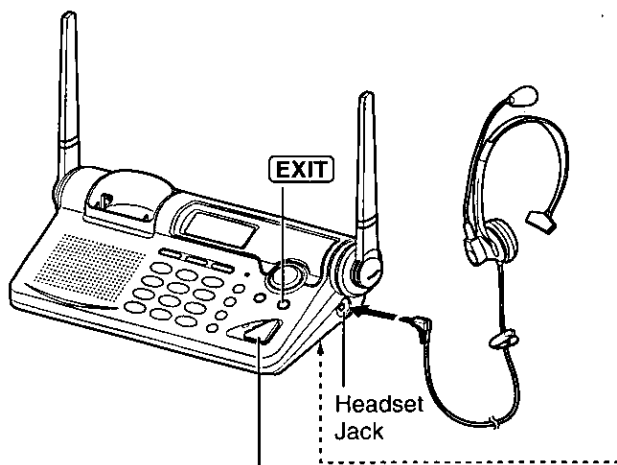

Fasten the headset cord to prevent it from being disconnected.

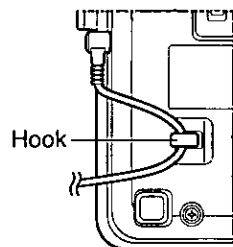

DIGITAL SP-PHONE/HEADSET

Making/Answering calls

- 1 Press **DIGITAL SP-PHONE/HEADSET** to make or answer a call.
 - If you misdial when making a call, press **DIGITAL SP-PHONE/HEADSET** twice and dial again.
- 2 To hang up, press **DIGITAL SP-PHONE/HEADSET**.

To adjust the headset receiver volume (High, Medium or Low):
While using the headset, press **▲** or **▼**.

To switch to the speakerphone while using the headset:

“EXIT=SP-phone” is displayed. Press **EXIT**.

To return to the headset, press **EXIT** again.

- Each time you press **EXIT**, the call will switch to the headset or speakerphone. While in the speakerphone mode, “EXIT=Headset” is displayed.

- During a conversation using the headset, you can switch the call to the handset by lifting it off the cradle.
- If you disconnect the headset during a conversation, you can continue the conversation with the speakerphone.

Adding Another Phone

This unit will not function during a power failure. To connect a standard telephone on the same line, use the Panasonic T-adaptor KX-J66. To order, call the accessories telephone number on page 2.

Standard Telephone

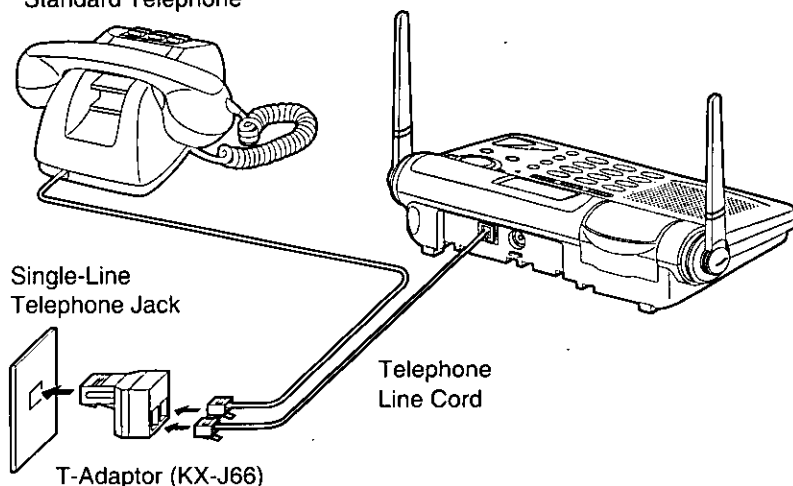

Fashion Plate™ Snap-On Color Covers (Optional)

You can change the look of your phone's handset with optional Fashion Plate™ snap-on color covers, KX-TGA10. Three different color covers are included; brownstone, charcoal and wineberry. To order, contact your dealer or call 1-800-211-PANA(7262) to locate a dealer.

- 1 Remove the battery cover by sliding it up while pressing the arrow. Remove the battery.

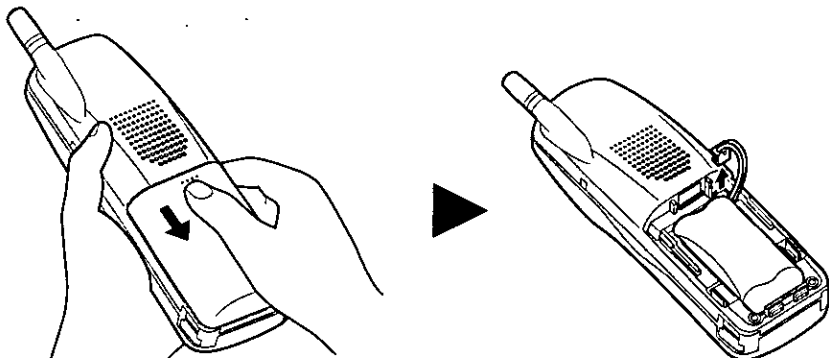

- 2 The color cover is held in place by the right and left tabs. Unlock one of the tabs by pressing horizontally (①) and vertically (②), and partially pull down the color cover (③, ④) as shown.

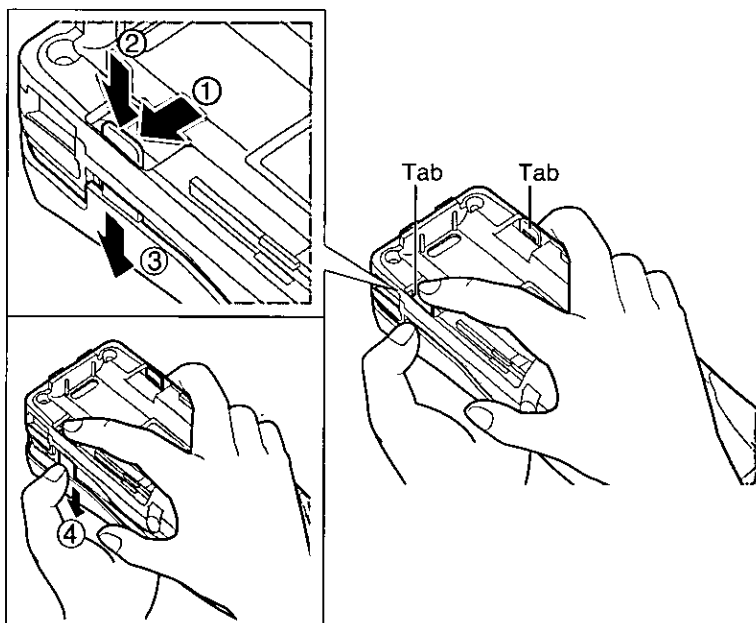

- 3** Unlock the other tab by pressing horizontally (①) and vertically (②), and partially pull down the color cover (③) in the same way. Completely remove the cover from the handset.

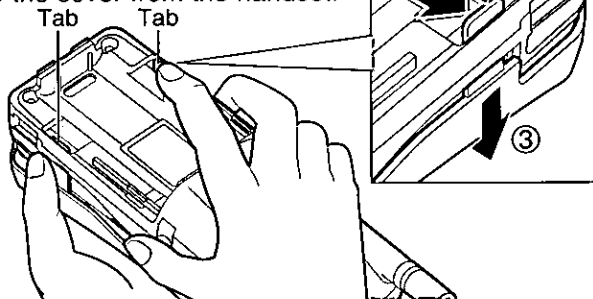

- 4** Place the new color cover, fitting the tabs on the cover into the slots on the handset.

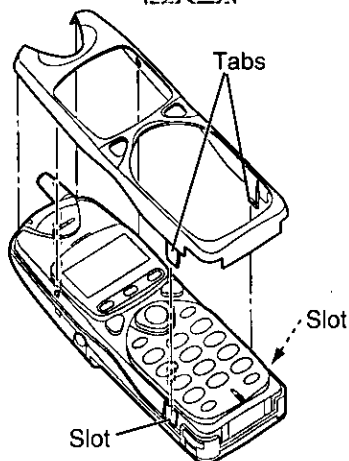

- 5** Snap the color cover shut on the lower (①), middle (②) and upper (③) parts of the handset.

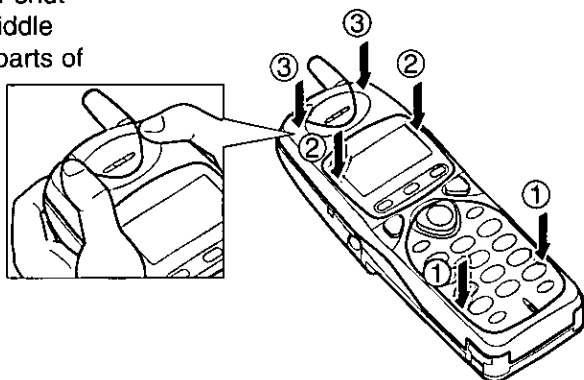

- 6** Connect the battery and close the battery cover (p. 58). Then insert the handset in the cradle until the ringer/charge indicator lights and a beep sounds.

•You need to confirm the handset ringer volume (p. 17).

Battery Replacement

If "Recharge battery" is displayed and/or "{ ■}" flashes after being fully charged, replace the battery with a new Panasonic HHR-P509 (PQHHR150AA23) battery. To order, call the accessories telephone number on page 2.

- 1 Remove the cover by sliding it up while pressing the arrow.

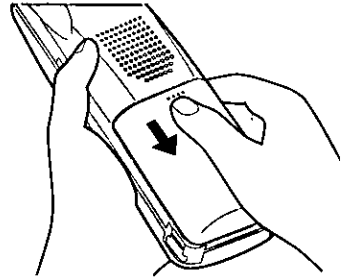

- 2 Remove the old battery. Then install the new one:

- ① Pinch the battery leads at the distance of about 10 mm from the battery plug with the red lead on the right and the black lead on the left.
- ② Insert the battery plug into the connector in the handset vertically.

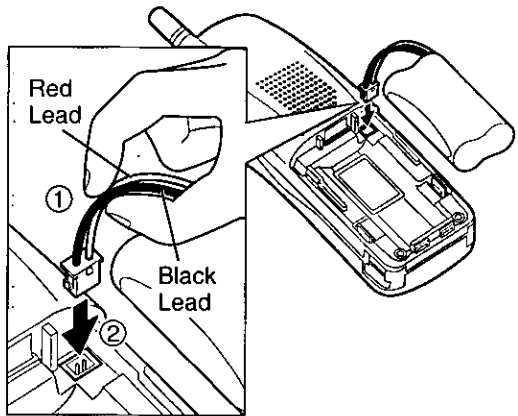

- ③ Press the plug with your finger tip to ensure it is firmly inserted.

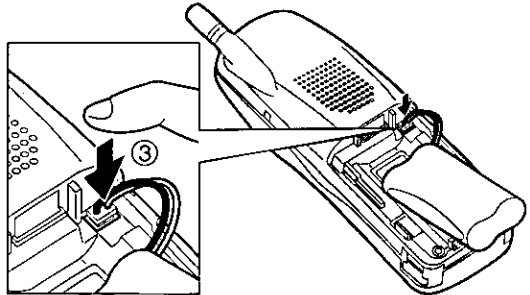

- 3 Close the cover. Make sure you charge the new battery for about 8 hours in order to display the battery strength prompt correctly (p. 11).

• You need to confirm the handset ringer volume (p. 17).

If the Following Appear...

If the unit detects a problem, one of the following messages will be displayed on the handset or the base unit.

Handset display

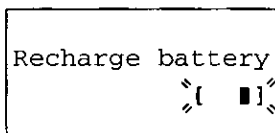

The battery needs to be charged. Insert the handset in the cradle to charge the battery (p. 11).

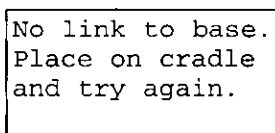

The handset has lost communication with the base unit. Insert the handset in the cradle and try again.

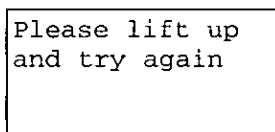

⏴, ⏵, ⏶ or ⏷ was pressed while the handset was on the base unit. Lift the handset and press the button again.

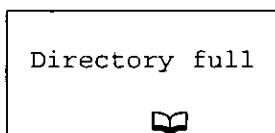

When trying to store an item or Caller List information in the directory, the directory memory is full (p. 32, 36). To erase other stored items from the directory, see page 43.

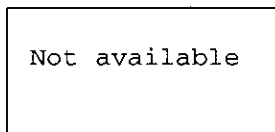

While the base unit was not in the standby mode, ⏴ or ⏵ was pressed to search the Caller List/directory list, ⏶ was pressed to select an option, or **CLEAR/INTERCOM** was pressed.

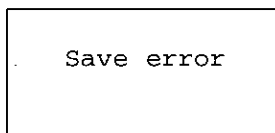

While storing items in the directory, the handset has lost communication with the base unit. Move closer to the base unit and try again.

Base unit display

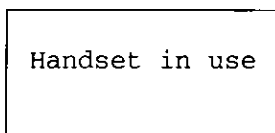







The display will be shown when the handset is in use (making/answering a call, viewing the Caller List or directory list, etc.).



Before Requesting Help



Problem	Remedy
"No link to base. Place on cradle and try again." is displayed and an alarm tone sounds.	<ul style="list-style-type: none">•You are too far from the base unit. Move closer and try again.•Insert the handset in the cradle and try again.•Plug in the AC adaptor.•Extend the handset antenna fully.•Raise the base unit antennas.
The unit does not work.	<ul style="list-style-type: none">•Check the settings (p. 10–14).•Charge the battery fully (p. 11).•Clean the charge contacts and charge again (p. 12).•Install the battery properly (p. 58).•Insert the handset in the cradle and unplug the AC adaptor to reset. Plug in, and try again.•Re-install the battery and insert the handset in the cradle (p. 58). Try again.
Static, sound cuts in/out, fades. Interference from other electrical units.	<ul style="list-style-type: none">•Locate the handset and the base unit away from other electrical appliances (p. 3).•Move closer to the base unit.•Extend the handset antenna fully.•Raise the base unit antennas.•Press FUNCTION/CH to select a clearer channel.
The handset and/or the base unit do not ring.	<ul style="list-style-type: none">•The ringer volume is set to OFF. Set to HIGH or LOW (p. 17).
The handset display is blank.	<ul style="list-style-type: none">•The handset is in the standby mode (p. 9). Press ▼, ▲, ◀ or ▶ to turn the display on.
The handset display is still blank after pressing ▼ , ▲ , ◀ or ▶ .	<ul style="list-style-type: none">•Charge the battery fully (p. 11).



Problem	Remedy
You cannot program items, such as the dialing mode.	<ul style="list-style-type: none">•Programming is not possible while the unit is in the talk or speakerphone mode or when viewing the Caller List/directory list.•Do not pause for over 60 seconds while programming.•Move closer to the base unit.•, ,  or  may have been pressed when you picked up the handset. Press OFF and try again.
Previously programmed information is erased.	<ul style="list-style-type: none">•If a power failure occurs, programmed information may be erased. Reprogram if necessary.
You cannot store a name and phone number in the directory.	<ul style="list-style-type: none">•You cannot store an item in the directory while the unit is in the talk, speakerphone or intercom mode.•Do not pause for over 60 seconds while storing.
While programming or searching, the unit starts to ring and stops the program/ search.	<ul style="list-style-type: none">•To answer the call, press ,  or DIGITAL SP-PHONE. Start again from the beginning after hanging up.
The unit does not display the caller's name and/or phone number.	<ul style="list-style-type: none">•You need to subscribe to a Caller ID service from a telephone company.•Other telephone equipment may be interfering with your phone. Disconnect it and try again.•Other electrical appliances connected to the same outlet may be interfering with the Caller ID information.•Telephone line noise may be affecting the Caller ID information.

➔ Before Requesting Help

Problem	Remedy
The handset or base unit display goes to the standby mode while viewing the Caller List.	<ul style="list-style-type: none">• Do not pause for over 60 seconds while searching.• ,  or DIGITAL SP-PHONE was pressed.
When a second call is received during a conversation, the unit does not display the new caller's name and/or phone number.	<ul style="list-style-type: none">• The line mode selection is incorrect. See page 14.
You cannot page the handset or the base unit.	<ul style="list-style-type: none">• The handset is too far from the base unit.• The handset or the base unit is engaged in an outside call or is viewing the Caller List/directory list. Try again later. If you are using the base unit, wait until "Handset in use" disappears.
You cannot redial by pressing REDIAL/PAUSE or REDIAL .	<ul style="list-style-type: none">• If the last number dialed was more than 32 digits long, the number will not be redialed correctly.• Access numbers entered after pressing STONE will not be included when redialing.• The REDIAL/PAUSE button on the handset has a double function as either redial or pause. It will redial the last number dialed if pressed at the outset of a call (p. 20). If another number has been dialed first, it will operate as a pause button (p. 49).
"Recharge battery" is displayed on the handset, "[■]" flashes or the unit beeps intermittently.	<ul style="list-style-type: none">• Charge the battery fully (p. 11).
You charged the battery fully, but "Recharge battery" is still displayed and/or "[■]" continues to flash.	<ul style="list-style-type: none">• Clean the charge contacts and charge again (p. 12).• Install a new battery (p. 58).

Problem	Remedy
The ringer/charge indicator light does not go out while charging.	<ul style="list-style-type: none"> •This is normal.
You cannot have a conversation using the headset.	<ul style="list-style-type: none"> •Make sure that the headset is connected properly (p. 54). • may have been pressed. If the button lights, press  to continue the conversation with the headset. •If "EXIT=Headset" is displayed on the base unit, press EXIT to switch from the speakerphone to the headset.
If you cannot solve your problem.	<ul style="list-style-type: none"> •Call our customer call center at 1-800-211-PANA(7262). •Panasonic's e-mail address for customer inquiries: consumerproducts@panasonic.com for customers in the USA or Puerto Rico ONLY

Important Safety Instructions

When using this unit, basic safety precautions should always be followed to reduce the risk of fire, electric shock, or personal injury.

1. Read and understand all instructions.
2. Follow all warnings and instructions marked on this unit.
3. Unplug this unit from AC outlets before cleaning. Do not use liquid or aerosol cleaners. Use a damp cloth for cleaning.
4. Do not use this unit near water, for example, near a bathtub, washbowl, kitchen sink, or the like.
5. Place this unit securely on a stable surface. Serious damage and/or injury may result if the unit falls.
6. Do not cover slots and openings on the unit. They are provided for ventilation and protection against overheating. Never place the unit near radiators, or in a place where proper ventilation is not provided.
7. Use only the power source marked on the unit. If you are not sure of the type of power supplied to your home, consult your dealer or local power company.
8. Do not place objects on the power cord. Install the unit where no one can step or trip on the cord.
9. Do not overload wall outlets and extension cords. This can result in the risk of fire or electric shock.
10. Never push any objects through slots in this unit. This may result in the risk of fire or electric shock. Never spill any liquid on the unit.
11. To reduce the risk of electric shock, do not disassemble this unit. Take the unit to an authorized servicer when service is required. Opening or removing covers may expose you to dangerous voltages or other risks. Incorrect reassembly can cause electric shock when the unit is subsequently used.
12. Unplug this unit from the wall outlet and refer servicing to an authorized servicer when the following conditions occur:
 - A. When the power supply cord or plug is damaged or frayed.
 - B. If liquid has been spilled into the unit.
 - C. If the unit has been exposed to rain or water.
 - D. If the unit does not work normally by following the operating instructions. Adjust only controls covered by the operating instructions. Improper adjustment may require extensive work by an authorized servicer.
 - E. If the unit has been dropped or physically damaged.
 - F. If the unit exhibits a distinct change in performance.
13. During thunderstorms, avoid using telephones except cordless types. There may be a remote risk of an electric shock from lightning.
14. Do not use this unit to report a gas leak, when in the vicinity of the leak.

SAVE THESE INSTRUCTIONS

CAUTION:

To reduce the risk of fire or injury to persons, read and follow these instructions.

1. Use only the battery(ies) specified.
2. Do not dispose of the battery(ies) in a fire. They may explode. Check with local waste management codes for special disposal instructions.
3. Do not open or mutilate the battery(ies). Released electrolyte is corrosive and may cause burns or injury to the eyes or skin. The electrolyte may be toxic if swallowed.
4. Exercise care in handling batteries in order not to short the battery to conductive materials such as rings, bracelets, and keys. The battery and/or conductor may overheat and cause burns.
5. Charge the battery(ies) provided with or identified for use with this product only in accordance with the instructions and limitations specified in this manual.

WARNING:

TO PREVENT FIRE OR SHOCK HAZARD, DO NOT EXPOSE THIS PRODUCT TO RAIN OR ANY TYPE OF MOISTURE.

- When left unused for a long period of time, the base unit should be unplugged from the household AC outlet.

FCC and Other Information

If requested by the telephone company, inform them as follows:

FCC Registration No. (found on the bottom of the unit)

Ringer Equivalence 0.1B

The particular telephone line to which the equipment is connected.

This unit must not be connected to a coin operated line.

If you are on a party line, check with your local telephone company.

Ringer Equivalence No. (REN):

The REN is useful in determining the quantity of devices you may connect to your telephone line and still have all of those devices ring when your telephone number is called. In most, but not all areas, the sum of the REN's of all devices connected to one line should not exceed five (5.0). To be certain of the number of devices you may connect to your line, as determined by the REN, you should contact your local telephone company to determine the maximum REN for your calling area.

In the event terminal equipment causes harm to the telephone network, the telephone company should notify the customer, if possible, that service may be stopped.

However, where prior notice is impractical, the company may temporarily cease service providing that they:

- (a) Promptly notify the customer.
- (b) Give the customer an opportunity to correct the problem with their equipment.
- (c) Inform the customer of the right to bring a complaint to the Federal Communication Commission pursuant to procedures set out in FCC Rules and Regulations Subpart E of Part 68.

The Telephone Company may make changes in its communications facilities, equipment, operations or procedures, where such action is reasonably required in the operation of its business and is not inconsistent with the rules and regulations in FCC Part 68.

If such changes can be reasonably expected to render any customer terminal equipment incompatible with telephone company communications facilities, or require modification or alteration of such terminal equipment, or otherwise materially affect its use or performance, the customer shall be given adequate notice in writing, to allow the customer an opportunity to maintain uninterrupted service.

When programming emergency numbers and/or making test calls to emergency numbers:

1. Remain on the line and briefly explain to the dispatcher the reason for the call before hanging up.
2. Perform such activities in the off-peak hours, such as early morning hours or late evenings.

This device complies with Part 15 of the FCC Rules. Operation is subject to the following two conditions: (1) This device may not cause harmful interference, and (2) this device must accept any interference received, including interference that may cause undesired operation.

Privacy of communications may not be ensured when using this phone.

CAUTION:

Any changes or modifications not expressly approved by the party responsible for compliance could void the user's authority to operate this device.

Note:

This equipment has been tested and found to comply with the limits for a Class B digital device, pursuant to Part 15 of the FCC Rules. These limits are designed to provide reasonable protection against harmful interference in a residential installation. This equipment generates, uses, and can radiate radio frequency energy and, if not installed and used in accordance with the instructions, may cause harmful interference to radio communications. However, there is no guarantee that interference will not occur in a particular installation. If this equipment does cause harmful interference to radio or television reception, which can be determined by turning the equipment off and on, the user is encouraged to try to correct the interference by one or more of the following measures:

- Reorient or relocate the receiving antenna.
- Increase the separation between the equipment and receiver.
- Connect the equipment into an outlet on a circuit different from that to which the receiver is connected.
- Consult the dealer or an experienced radio/TV technician for help.

Some cordless telephones operate at frequencies that may cause interference to nearby TVs and VCRs. To minimize or prevent such interference, the base of the cordless telephone should not be placed near or on top of a TV or VCR. If interference is experienced, move the cordless telephone further away from the TV or VCR. This will often reduce, or eliminate, interference.

Operating near 2.4GHz electrical appliances may cause interference. Move away from the electrical appliances and/or press the CH (Channel) button.

- **Environment** — do not place the unit in a room where the temperature is less than 5°C (41°F) or greater than 40°C (104°F). Allow 10 cm (4") clearance around the unit for proper ventilation. Avoid excessive smoke, dust, mechanical vibration, shock, or direct sunlight.
- **Medical** — consult the manufacturer of any personal medical devices, such as pacemakers, to determine if they are adequately shielded from external RF (radio frequency) energy. (The unit operates in the frequency range of 2401MHz to 2472MHz, and the power output level can range from 0.001 watts to 0.20 watts.) Do not use the unit in health care facilities if any regulations posted in the area instruct you not to do so. Hospitals or health care facilities may be using equipment that could be sensitive to external RF (radio frequency) energy.
- **Routine care** — wipe the unit with a soft cloth. Do not use benzene, thinner, or any abrasive powder. When you leave the unit unused for a long period of time, unplug the AC adaptor from the outlet.
- **If there is any trouble** — disconnect the unit from the telephone line and connect a known working phone. If the known working phone operates properly, have your unit repaired by one of the authorized Panasonic Factory Service Centers. If the known working phone does not operate properly, consult your telephone company.

For product service

- Panasonic Servicenters are listed in the servicenter directory.
- Call 1-800-211-PANA(7262) for the location of an authorized servicenter.
- Panasonic's e-mail address for customer inquiries:
consumerproducts@panasonic.com
for customers in the USA or Puerto Rico ONLY

When you ship the product

- Carefully pack your unit, preferably in the original carton.
- Attach a letter, detailing the symptom, to the outside of the carton.

Symptom

- Send the unit to an authorized servicenter, prepaid and adequately insured.
- Do not send your unit to the Panasonic Consumer Electronics Company listed below or to executive or regional sales offices. These locations do not repair consumer products.

- This cordless telephone is designed for use in the United States of America. Sale or use of this product in other countries may violate local laws.
- Ce téléphone sans fil est conçu pour être utilisé aux États-Unis d'Amérique. La vente ou l'emploi de cet appareil dans certains autres pays peut constituer une infraction à la législation locale.
- Este teléfono sin cordón fue elaborado para uso en los Estados Unidos de América. La venta o el empleo de este producto en ciertos países puede constituir violación de la legislación local.
- このコードレス電話機は、日本国外での使用を目的として設計されており、日本国内での使用は法律違反となります。従って、当社では日本国内においては修理などのサービスは致しかねます。

Panasonic Consumer Electronics Company,
Division of Matsushita Electric Corporation of America
One Panasonic Way, Secaucus, New Jersey 07094

Panasonic Sales Company,
Division of Matsushita Electric of Puerto Rico, Inc.
Ave. 65 de Infantería, Km. 9.5, San Gabriel Industrial Park
Carolina, Puerto Rico 00985