

Hallicrafters, Inc.

Model: SX-24

Chassis:

Year: Pre August 1939

Power:

Circuit:

IF:

Tubes:

Bands:

Resources

[Riders Volume 10 - HALLICRAFTERS 10-10](#)

[Riders Volume 10 - HALLICRAFTERS 10-15](#)

[Riders Volume 10 - HALLICRAFTERS 10-16](#)

MODEL SX23
Super Skyrider
Operating Data
Antenna Notes

THE HALLICRAFTERS INC.

MODEL SX24
Skyrider Defiant
Antenna Notes

The "RF Gain" control adjusts the sensitivity of the receiver by varying the cathode bias on the RF and IF amplifiers. Maximum sensitivity will be obtained with this control rotated clockwise as far as it will go. When this is done a switch will be operated, the function of which will be described under 5 meter.

When using the receiver under varying local conditions of noise, it will be advisable to adjust both the "RF" and "IF" gain controls until the most favorable signal to noise ratio is found. Until such a time as you have become thoroughly familiar with the function of all controls it is suggested that the R. F. Gain be advanced until the white dot on the knob is pointing approximately at the "85" on SKRIDER. Later experiment to find the best position for a given signal bearing in mind that with the selectivity switch in any of the

CRYSTAL OPERATION

There are three controls which must be properly adjusted for most satisfactory crystal filter operation. Their operation shall be treated in the order in which they are called upon to perform their functions in the receiver.

Selectivity Switch -

There are three positions of selectivity with the Automatic Volume Control circuit operating. For high fidelity broadcast reception the selectivity switch should be rotated to the "IF Broad" position.

With the switch placed in the "IF Sharp" position the selectivity is greatly increased at no apparent sacrifice in tone reproduction.

The "Phone Crystal" position affords maximum selectivity with automatic volume control. The receiver will have to be accurately retuned on each desired signal because this step of selectivity greatly attenuates the sidebands of a modulated carrier. You will notice the apparent slot into which the signal falls, only in the exact center of which will be intelligibility of a good order be maintained. The "Phone Crystal" position is recommended under conditions of extreme interference where adjacent channel stations are causing objectionable heterodynes.

Rotating the switch in a counter-clockwise position still farther allows the receiver to be used in the three selectivity positions with the A.V.C. circuit disconnected. When the selectivity switch is so adjusted it is then necessary to manually adjust the "RF Gain" to keep the signal under control.

In the "CW Crystal" position the maximum selectivity of the set is obtained. The drop in background noise is immediately apparent. This position is recommended only for the reception of CW or code signals because the selectivity is so great phone signals are practically unreadable. To realize the maximum in performance from the SKRIDER 23 crystal circuit, the following two controls should be adjusted as described. First tune in an extremely strong CW signal.

The "Pitch Control" should be turned until a beat note is audible. Then adjust the main tuning control and go across the signal. Two distinct signals will be heard either side of zero beat, or the null position in the center tuning through which no signal is audible. See whether the low or the high frequency side of the signal (that which appears either side of zero beat) is the weaker. Loosen the receiver set screw whichever of the two signals is the weaker. Now very carefully adjust the "Pitching Control" until you have eliminated that signal as much as possible. As an additional step, to "pitch" the signal through zero beat proper low or high frequency image to reject, rotate the "Pitch Control" through zero beat to the other side so that a beat note is apparent. This same pitch as before is obtained. Now return the receiver and it will be apparent that this signal was first tuned in) is beat (as referred to the markings on the dial at which this signal was first tuned in) is reduced in volume. Again carefully adjust the "Pitching Control" and compare the strength of the audio image when this side has been phased out, or rejected. When you have demonstrated that the phasing or rejection is better on either the low or high frequency audio image the phasing control is left in that position and you then have the SKRIDER 23 adjusted for the extremely selective crystal action for which it is noted.

The "Pitch and Phasing Controls" should be called upon frequently to demonstrate how, through proper adjustment, extreme conditions of interference can be coped with. Frequently, a slight adjustment of the pitch control will place a desired signal in the clear when the two signals differ in frequency by only a few hundred cycles. Minute adjustment of the phasing control will frequently obliterate an interfering signal by dropping it in the crystal slot.

SUPER SKYRIDER MODEL SX23

ANTENNA:

The SKRIDER 23 has an antenna input circuit which will allow the use of either a doublet or Marconi (inverted "L") antenna. The approximate antenna input impedance of the SKRIDER is 400 ohms. A very serviceable antenna will be the inverted "L", or Marconi type. This antenna should be approximately 75 feet long overall, including the lead-in to the set. Satisfactory operation of the SKRIDER 23 is obtained throughout its tuning range with this type of antenna and because of that fact as well as its ease of construction it is highly recommended. Should a doublet antenna be used it is suggested that a transmission line of 400 ohms value of impedance be constructed so that a most efficient transfer of energy is obtained. The components available in all wave doublet antennas are usually provided with a coupling transformer which matches the transmission line to the receiver. This transformer connects to the A1 and A2 terminals on the antenna strip. The half-wave length-doublet antenna cut for a particular frequency can be computed by the following formula:

$$\text{Length in feet} = \frac{468}{\text{Frequency in megacycles}}$$

This type of antenna is broken in the center with an insulator and has the transmission line connected to each resulting quarter wave section at that point. This antenna is a very good performer, in a direction broadside to its length, only on the relatively narrow group of frequencies for which it was cut. It does not function well on harmonic frequencies.

When using either type of doublet antenna the transmission line should be connected to A1 and A2 binding posts. The wire connecting the A2 to ground or G can be left connected if the performance of the receiver is improved.

CONTROLS AND OPERATION

Each of the controls is identified by appropriate marking on the panel. The "Tone Control" turns the receiver "on" and "off", and also allow the operator to make adjustments for the type of reproduction most pleasing to him. Treble reproduction is to the far left position, just after the set is turned on, while the base is at the extreme right. Intermediate positions allow for any desired degree of mixing.

The "Pitch Control" is to be used when code or CW signals are being received. In its counter-clockwise position the Beat Frequency Oscillator is "off". Rotating the control clockwise turns on the B.F.O. in addition to varying the pitch of the beat note to the operator's taste.

Directly below the two controls mentioned will be found the "Phone Jack". Any type of high impedance headphones may be used because no direct current flows in the headphones circuit. The strength of the signal in the headphones will be found to be at the proper level for most comfortable headphones reception. When headphones are used the speaker is automatically disconnected.

The "RF Gain" control adjusts the volume of the receiver by varying the output of the audio amplifier. Volume is controlled in both the headphones and loud speaker circuits and the setting of this control is optional with the user of the receiver for the amount of volume desired. The "Off" position is optional with the user of the receiver for the amount of volume desired. The "Off" position is optional with the user of the receiver for the amount of volume desired. The "Off" position is optional with the user of the receiver for the amount of volume desired.

The "Stand-By" or "Stand-Receiver" switch when in the "Stand" position removes plate voltage from the tubes. This allows the receiver to be made temporarily inoperative should it be used in conjunction with a transmitter.

The hand-wheel marked "Tuning", is for adjusting the main dial to the frequency desired. The mechanism is quiet in operation and free from back lash. The conventionally located control will give the greatest tuning ease after continued hours of operation. The "AMT" or Automatic Noise Limiter control turns the noise limiter "on" or "off". No modern communications receiver is complete without an effective noise limiter. With the A.M.L. switch in the "on" position the noise limiter will prove to be of great assistance and frequently mean the difference between hearing a signal which otherwise would be inaudible on the higher frequencies where ignition and other pulsating types of interference are most aggravating.

Schematic

THE HALLICRAFTERS INC.

MODEL SX24
Skyrider Defiant

Unless otherwise specified the SX24 Receiver operates on 100-125 volt 50-60 cycle current.

TUBE LINE-UP

- 6SK7 R.F. Amplifier
- 6K8 1st Detector-Mixer H.F. Oscillator
- 6SK7 1st I.F. Amplifier
- 6SK7 2nd I.F. Amplifier
- 6SQ7 2nd Detector, A.V.C. 1st stage of audio
- 6F6 2nd audio output stage
- 6HG Automatic Noise Limiter
- 76 Beat Frequency Oscillator
- 80 Rectifier

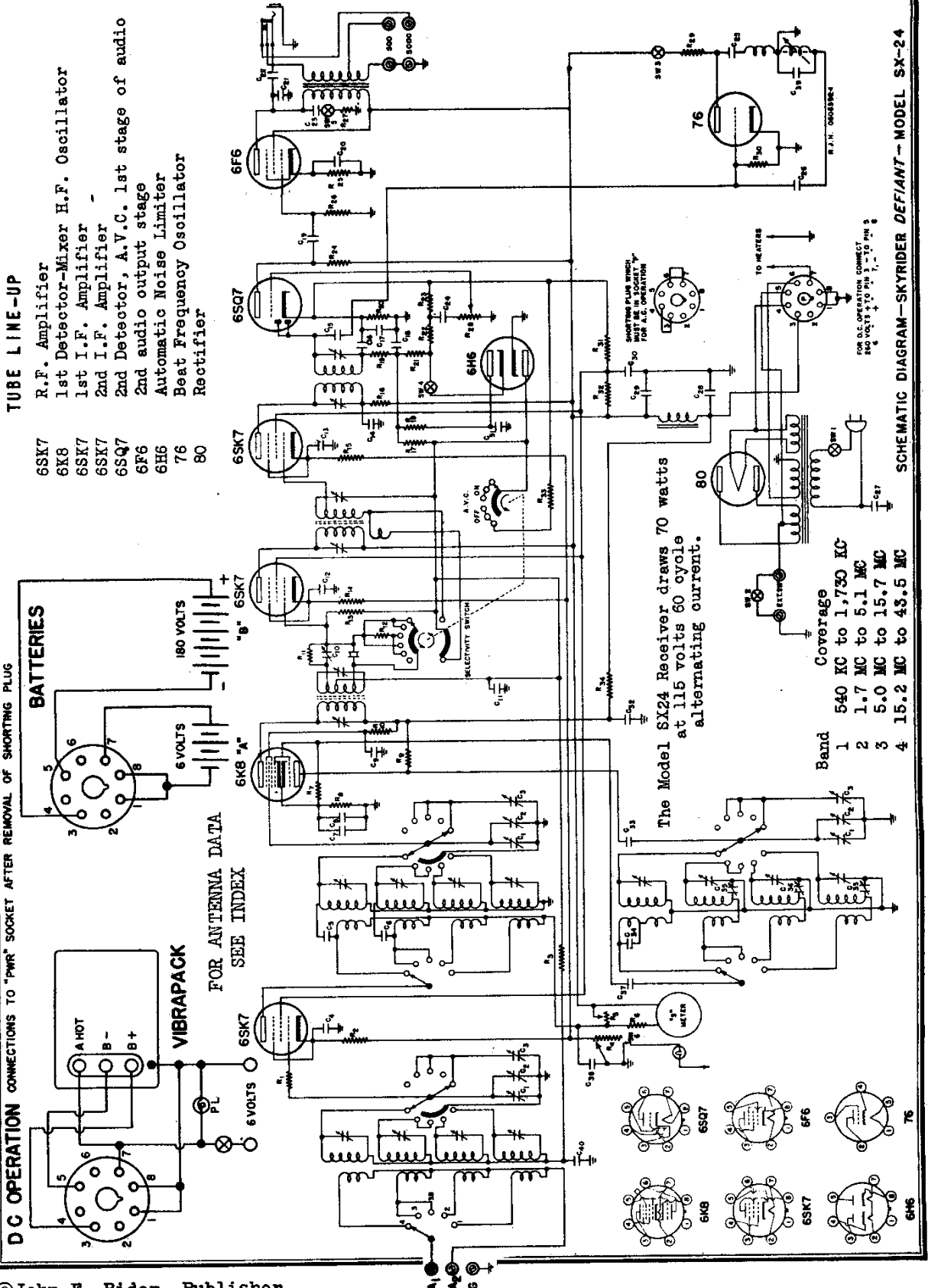

The Model SX24 Receiver draws 70 watts at 115 volts 60 cycle alternating current.

Band	Coverage
1	540 KC to 1,730 KC
2	1.7 MC to 5.1 MC
3	5.0 MC to 15.7 MC
4	15.2 MC to 43.5 MC

DC OPERATION CONNECTIONS TO "PW" SOCKET AFTER REMOVAL OF SHORTING PLUG

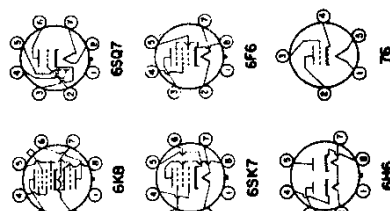
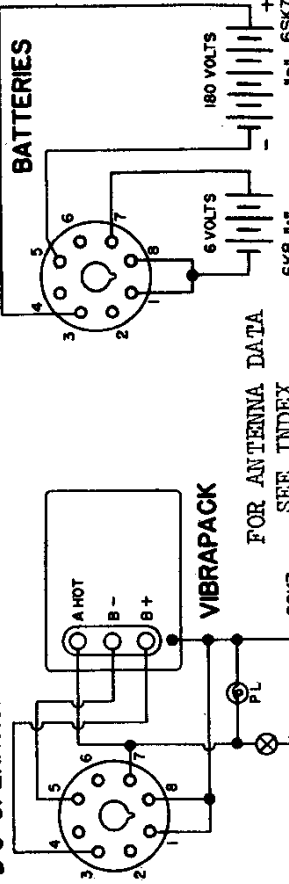

SCHEMATIC DIAGRAM—SKYRIDER DEFIANT—MODEL SX-24

MODEL SX24, Skyriider Defiant

Socket, Trimmers
Parts List
Alignment

THE HALLICRAFTERS INC.

CONDENSERS		RESISTORS	
NO.	CAPACITY	VOLTAGE	TYPE
1	.005 mfd	600	Paper
2	.01	400	"
3	.02	600	"
4	.02	200	"
5	.01	400	"
6	100.		Mica
7	.01 mfd	600	Paper
8	.01	350	Electrolytic
9	.01	400	Electrolytic
10	.01	400	Paper
11	.05	200	"
12	.05	200	"
13	.05	200	"
14	.05	200	"
15	.05	200	"
16	100.		Mica
17	10. mfd	25	Electrolytic
18	50. mfd	400	Mica
19	.05 mfd	400	Paper
20	10.	25	Electrolytic
21	.005 mfd	600	Paper
22	.01	400	"
23	.02	600	"
24	.02	200	"
25	.01	400	"
26	100.		Mica
27	.01 mfd	600	Paper
28	.01	350	Electrolytic
29	.01	400	Electrolytic
30	.01	400	Paper
31	.05	200	"
32	.05	200	"
33	.05	200	"
34	105		Mica
35	450		Ceramic
36	1400		"
37	.002 mfd		"
38	.05	400	"
39	.0005		"
40	.05	200	"

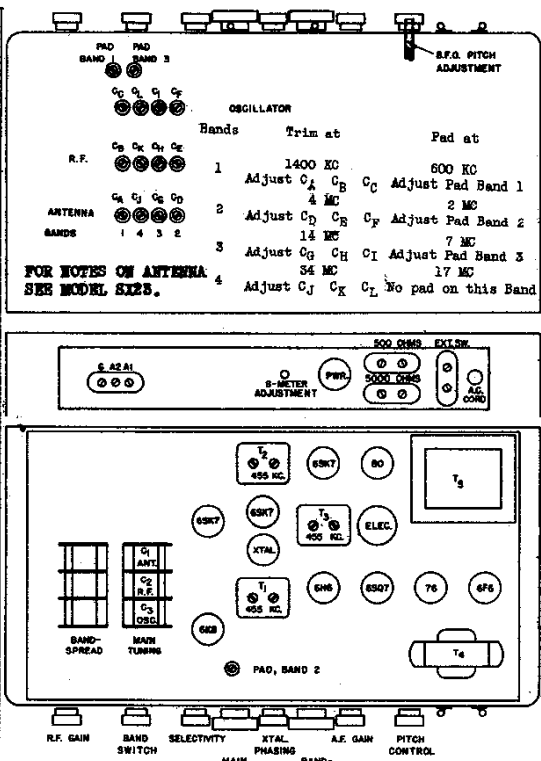

Notes: The accuracy of the main dial calibration will hold only if the BAND SPREAD condenser is set at minimum capacity, or the position indicated by "0" on the Band Spread dial which has been approached by turning the Band Spread knob in a clockwise direction, or to the right, as far as it will go.

NO.	OHMS	WATTAGE	OHMS	WATTAGE
1	30	1/3	18	1,000,000
2	200	"	19	50,000
3	100,000	"	20	100
4	10,000	R.F. Gain Control	21	250,000
5	500	Variable	22	100,000
6	400	"	23	250,000
7	50,000	"	24	250,000
8	200	"	25	500
9	15,000	"	26	500
10	30,000	"	27	5,000
11	2,000,000	A.F. Gain Control	28	20,000
12	50,000	"	29	50,000
13	500,000	"	30	20,000
14	500	"	31	20,000
15	500	"	32	15,000
16	1,000	"	33	150
17	1,000,000	"	34	5,000

ALIGNMENT PROCEDURE
465 KC, Intermediate-Frequency Alignment.
Have the controls set as follows:
AF and RF gain controls for maximum volume.
Remove 6K8 grid cap and connect the hot side of your 465 KC generator to this tube. Connect the ground terminal of the signal generator to the chassis of the receiver. Now feed a 465 KC signal into the receiver and set the pitch control to give a beat note of approximately 1000 cycles. Adjust all I.F. transformer trimmers for maximum gain with the exception of the secondary trimmer on transformer T1. In adjusting this trimmer it will be noted that the output reaches a maximum goes through a dip and then back to maximum again. Wobulate the IF frequency and align to the dip between the two maximum points. A distinct change in the crystal note sounding like an apparent broadening of the crystal action will be noted when the correct adjustment has been reached. Now repeat carefully the other trimmers for maximum gain.

8. F. ALIGNMENT
Re-connect the grid cap to the 6K8 tube. Connect the hot side of the generator to the A1 antenna terminal on the rear of the chassis. Be sure a jumper is connected to A2 and C. Leave signal generator ground connected to the chassis of the receiver.
The location of the following trimmers and padders can be determined by referring to the top and bottom chassis views. All pad adjustments are for the low frequency end of each band while the trimmers are for the high frequency ends.

In order to get at the RF trimmers the guarantee card can be removed by placing a knife under the small snap fasteners holding it in place. So that most satisfactory adjustment of the trimmers and padders can be made, it is advisable to "hook" the condenser gang across the signal being delivered by the generator until that particular circuit has been accurately peaked.

"S" METER
When the R.F. gain control is advanced until a switch is heard to operate, a light will appear behind the translucent scale of the meter itself. Only when this light is on will the meter indicate in "S" units. With the R.F. gain control backed off from maximum the meter is still in the circuit but will not indicate carrier level accurately. When so adjusted the meter can be used as a resonance indicator. On the rear apron of the chassis is the "S" meter adjustment screw. To set the "S" meter, disconnect the antenna and have the R.F. Gain Control on full and the selectivity switch in the "I.F. sharp A.V.C. on" position. Now, adjust this knurled knob until the meter reads zero. Reconnecting the antenna and tuning in a station will show its relative carrier intensity.

The 500 and 6000 ohm terminals are for connections to a loud speaker or other load of those impedance values. The matching 5225 speaker should be connected to the 6000 ohm strip. When headphones are plugged into the phone jack the 6000 ohm speaker connection is automatically disconnected.