

HEATHKIT[®] MANUAL

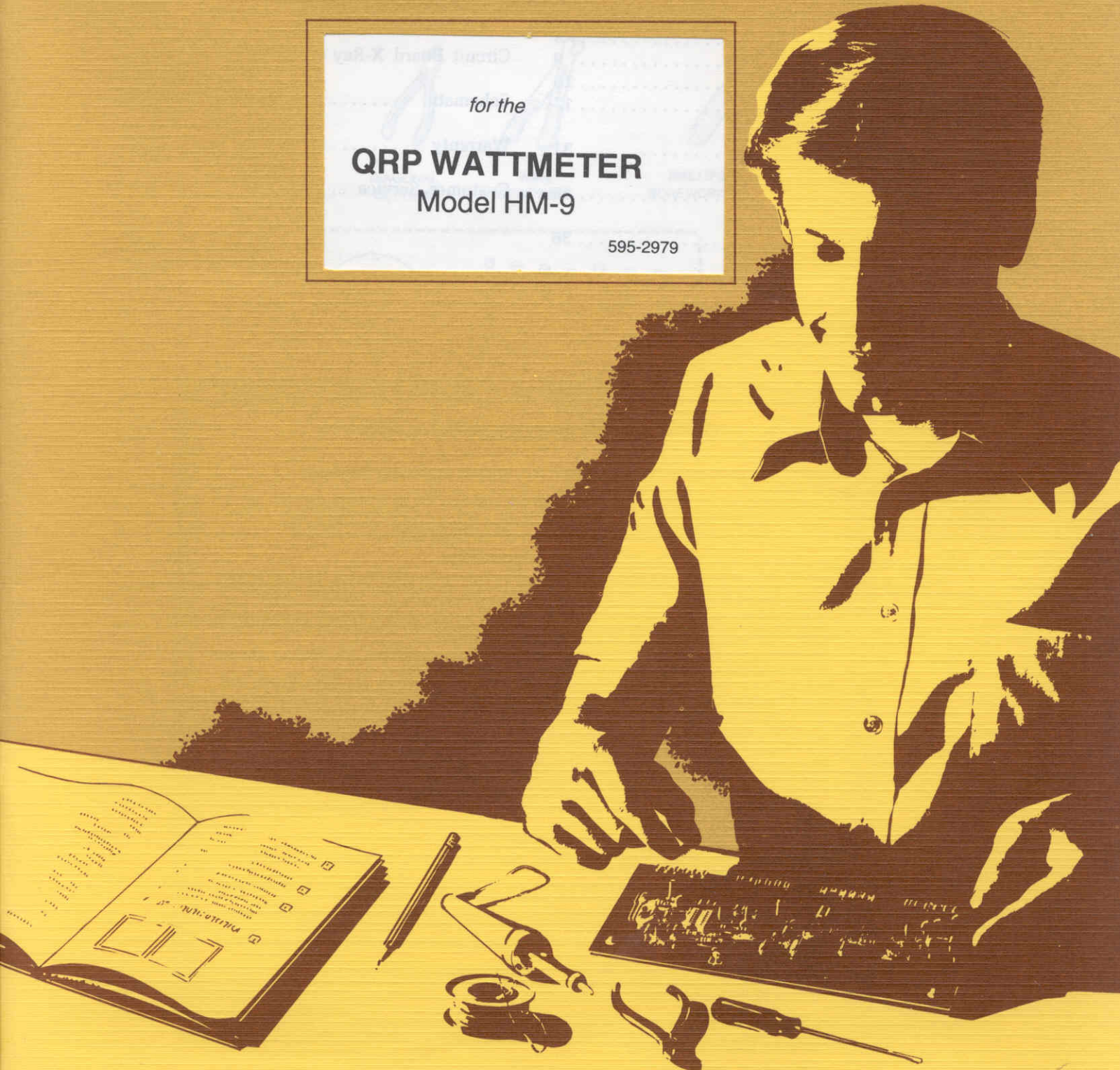
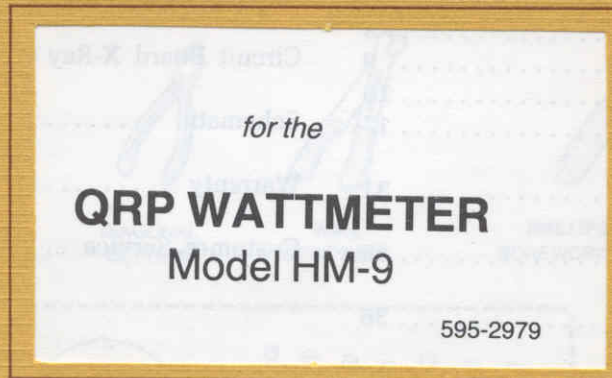

HEATH COMPANY • BENTON HARBOR, MICHIGAN

HEATH COMPANY PHONE DIRECTORY

The following telephone numbers are direct lines to the departments listed:

Kit orders and delivery information (616) 982-3411
Credit (616) 982-3561
Replacement Parts (616) 982-3571

Technical Assistance Phone Numbers

8:00 A.M. to 12 P.M. and 1:00 P.M. to 4:30 P.M., EST, Weekdays Only
R/C, Audio, and Electronic Organs (616) 982-3310
Amateur Radio (616) 982-3296
Test Equipment, Weather Instruments and
Home Clocks (616) 982-3315
Television (616) 982-3307
Aircraft, Marine, Security, Scanners, Automotive,
Appliances and General Products (616) 982-3496
Computers — Hardware (616) 982-3309
Computers — Software:
Operating Systems, Languages, Utilities (616) 982-3860
Application Programs (616) 982-3884
Heath Craft Wood Works (616) 982-3423



YOUR HEATHKIT 90-DAY LIMITED WARRANTY

Consumer Protection Plan for Heathkit Consumer Products

Welcome to the Heath family. We believe you will enjoy assembling your kit and will be pleased with its performance. Please read this Consumer Protection Plan carefully. It is a "LIMITED WARRANTY" as defined in the U.S. Consumer Product Warranty and Federal Trade Commission Improvement Act. This warranty gives you specific legal rights, and you may also have other rights which vary from state to state.

Heath's Responsibility

PARTS — Replacements for factory defective parts will be supplied free for 90 days from date of purchase. Replacement parts are warranted for the remaining portion of the original warranty period. You can obtain warranty parts direct from Heath Company by writing or telephoning us at (616) 982-3571. And we will pay shipping charges to get those parts to you . . . anywhere in the world.

SERVICE LABOR — For a period of 90 days from the date of purchase, any malfunction caused by defective parts or error in design will be corrected at no charge to you. You must deliver the unit at your expense to the Heath factory, any Heathkit Electronic Center (units of Veritechnology Electronics Corporation), or any of our authorized overseas distributors.

TECHNICAL CONSULTATION — You will receive free consultation on any problem you might encounter in the assembly or use of your Heathkit product. Just drop us a line or give us a call. Sorry, we cannot accept collect calls.

NOT COVERED — The correction of assembly errors, adjustments, calibration, and damage due to misuse, abuse, or negligence are not covered by the warranty. Use of corrosive solder and/or the unauthorized modification of the product or of any furnished component, will void this warranty in its entirety. This warranty does not include reimbursement for inconvenience, loss of use, customer assembly, set-up time, or unauthorized service.

This warranty covers only Heath products and is not extended to other equipment or components that a customer uses in conjunction with our products.

SUCH REPAIR AND REPLACEMENT SHALL BE THE SOLE REMEDY OF THE CUSTOMER AND THERE SHALL BE NO LIABILITY ON THE PART OF HEATH FOR ANY SPECIAL, INDIRECT, INCIDENTAL OR CONSEQUENTIAL DAMAGES, INCLUDING BUT NOT LIMITED TO ANY LOSS OF BUSINESS OR PROFITS, WHETHER OR NOT FORSEEABLE.

Some states do not allow the exclusion or limitation of incidental or consequential damages, so the above limitation or exclusion may not apply to you.

Owner's Responsibility

EFFECTIVE WARRANTY DATE — Warranty begins on the date of first consumer purchase. You must supply a copy of your proof of purchase when you request warranty service or parts.

ASSEMBLY — Before seeking warranty service, you should complete the assembly by carefully following the manual instructions. Heathkit service agencies cannot complete assembly and adjustments that are customer's responsibility.

ACCESSORY EQUIPMENT — Performance malfunctions involving other non-Heath accessory equipment, (antennas, audio components, computer peripherals and software, etc.) are not covered by this warranty and are the owner's responsibility.

SHIPPING UNITS — Follow the packing instructions published in the assembly manuals. Damage due to inadequate packing cannot be repaired under warranty.

If you are not satisfied with our service (warranty or otherwise) or our products, write directly to our Director of Customer Service, Heath Company, Benton Harbor MI 49022. He will make certain your problems receive immediate, personal attention.

TABLE OF CONTENTS

Introduction 2

Assembly Instructions 3

Parts List 4

Step-by-Step Assembly 5

Circuit Board Assembly 6

Circuit Board Checkout 7

Chassis Assembly 8

Calibration 9

Final Assembly 10

Operation 11

Heathkit® Manual

for the

QRP WATTMETER Model HM-9

595-2979

INTRODUCTION

This information is of great value to you as you make adjustments and determine the allowable frequency working range of the instrument.

This instrument is designed for use only with a load impedance of 50 ohms nominal characteristic impedance and it has negligible insertion loss. The wattmeter is contained in a small cabinet.

As you assemble your kit, you can install components (supplied) to make the Wattmeter operate from 1.5-30 MHz, 50-54 MHz or 1.5-144 MHz.

The small size, easy assembly, and simple adjustment make the Wattmeter a handy addition to any ham's shack for both QRP operation and general use.

The Heathkit Model HM-9 QRP Wattmeter is a reliable instrument for measuring RF power output and the SWR of an antenna radio section or other similar type of transmitting systems. The range allows you to easily and accurately measure power levels up to 5 watts or 60 watts. You can also use the Wattmeter to measure the SWR of your antenna system. The Wattmeter may be permanently installed in the transmission line without affecting the transmitting and receiving capabilities of your station.

The Wattmeter slide proper installation being by first disconnecting forward power when the wattmeter is used to the SWR setting the meter measures the mismatch between the transmission line connected to the input connector and the load connected to the output connector.

TABLE OF CONTENTS

Introduction	2	In Case of Difficulty	38
Assembly Notes	3	Troubleshooting Chart	38
Parts List	6	Specifications	39
Step-by-Step Assembly	9	Circuit Description	40
Circuit Board Assembly	9	Circuit Board X-Ray View	41
Circuit Board Checkout	16	Schematic	(Illustration Booklet, Page 5)
Chassis Assembly	17	Warranty	Inside front cover
Calibration	31	Customer Service	Inside rear cover
Final Assembly	35		
Operation	36		

INTRODUCTION

The Heathkit Model HM-9 QRP Wattmeter is a reliable instrument for measuring RF power output and the SWR of an amateur radio station or other similar types of transmitting systems. Two ranges allow you to easily and accurately measure power levels up to 5 watts or 50 watts. You can also use the Wattmeter to measure the SWR of your antenna system. The Wattmeter may be permanently installed in the transmission line without affecting the transmitting and receiving capabilities of your station.

The Wattmeter aids proper transmitter tuning by indicating maximum forward power when the transmitter is tuned. In the SWR setting, the meter measures the mismatch between the transmission line connected to the input connector and the load connected to the output connector.

This information is of great value when you are making antenna adjustments and determining the allowable frequency working range of the antenna.

This instrument is designed for use only with a transmission line of 50 ohms nominal characteristic impedance, and it has negligible insertion loss. The entire Wattmeter is contained in a small cabinet.

As you assemble your kit, you can install components (supplied) to make the Wattmeter operate from 1.8—30 MHz, 50—54 MHz, or 144—148 MHz.

The small size, easy assembly, and simple alignment make this Wattmeter a handy addition to any ham-shack for avid QRP operators, newcomers or old timers alike.

ASSEMBLY NOTES

TOOLS

You will need these tools to assemble your kit.

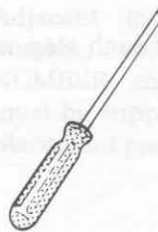

PLIERS

LONG-NOSE
PLIERSDIAGONAL
CUTTERSWIRE
STRIPPERSPHILLIPS
SCREWDRIVER.062"
ALLEN
WRENCH

OTHER HELPFUL TOOLS

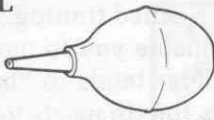
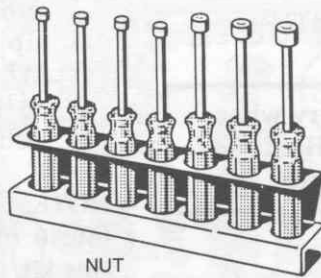
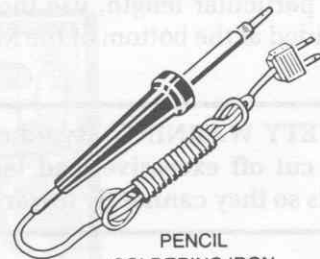
NUT STARTER
(May Be Supplied
With Kit)DESOLDERING
BULB*DESOLDERING
BRAID*NUT
DRIVERSPENCIL
SOLDERING IRON
(22 to 25 WATTS)

*To Remove Solder From Circuit Connections.

ASSEMBLY

- Follow the instructions carefully. Read the entire step before you perform each operation.
- The illustrations in the Manual are called Pictorials and Details. Pictorials show the overall operation for a group of assembly steps; Details generally illustrate a single step. When you are directed to refer to a certain Pictorial "for the following steps," continue using that Pictorial until you are referred to another Pictorial for another group of steps.
- Most kits use a separate "Illustration Booklet" that contains illustrations (Pictorials, Details, etc.) that are too large for the Assembly Manual. Keep the "Illustration Booklet" with the Assembly Manual. The illustrations in it are arranged in Pictorial number sequence.
- Position all parts as shown in the Pictorials.
- Solder a part or a group of parts only when you are instructed to do so.

6. Each circuit part in an electronic kit has its own component number (R2, C4, etc.). Use these numbers when you want to identify the same part in the various sections of the Manual. These numbers, which are especially useful if a part has to be replaced, appear:
- In the Parts List,
 - At the beginning of each step where a component is installed,
 - In some illustrations,
 - In the Schematic,
 - In the section at the rear of the Manual.
7. When you are instructed to cut something to a particular length, use the scales (rulers) provided at the bottom of the Manual pages.

SAFETY WARNING: Avoid eye injury when you cut off excessive lead lengths. Hold the leads so they cannot fly toward your eyes.

SOLDERING

Soldering is one of the most important operations you will perform while assembling your kit. A good solder connection will form an electrical connection between two parts, such as a component lead and a circuit board foil. A bad solder connection could prevent an otherwise well-assembled kit from operating properly.

It is easy to make a good solder connection if you follow a few simple rules:

1. Use the right type of soldering iron. A 22 to 25-watt pencil soldering iron with a 1/8" or 3/16" chisel or pyramid tip works best.
2. Keep the soldering iron tip clean. Wipe it often on a wet sponge or cloth; then apply solder to the tip to give the entire tip a wet look. This process is called tinning, and it will protect the tip and enable you to make good connections. When solder tends to "ball" or does not stick to the tip, the tip needs to be cleaned and retinned.

NOTE: Always use rosin core, radio-type solder (60:40 tin-lead content) for all of the soldering in this kit. This is the type we have supplied with the parts. The Warranty will be void and we will not service any kit in which acid core solder or paste has been used.

PARTS

Resistors are identified in Parts Lists and steps by their resistance value in Ω (ohms), $k\Omega$ (kilohms), or $M\Omega$ (megohms). They are usually identified by a color code and four or five color bands, where each color represents a number. These colors (except for the last band, which indicates a resistor's "tolerance") will be given in the steps in their proper order. Therefore, the following color code is given for information only. NOTE: Occasionally, a "precision" or "power" resistor may have the value stamped on it.

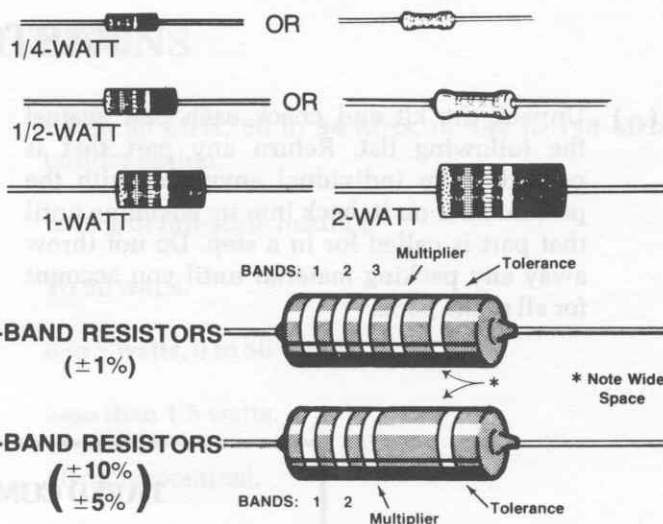

Band 1 1st Digit		Band 2 2nd Digit		Band 3 (if used) 3rd Digit		Multiplier		Resistance Tolerance	
Color	Digit	Color	Digit	Color	Digit	Color	Multiplier	Color	Tolerance
Black	0	Black	0	Black	0	Black	1	Silver	±10%
Brown	1	Brown	1	Brown	1	Brown	10	Gold	±5%
Red	2	Red	2	Red	2	Red	100	Brown	±1%
Orange	3	Orange	3	Orange	3	Orange	1,000		
Yellow	4	Yellow	4	Yellow	4	Yellow	10,000		
Green	5	Green	5	Green	5	Green	100,000		
Blue	6	Blue	6	Blue	6	Blue	1,000,000		
Violet	7	Violet	7	Violet	7	Silver	0.01		
Gray	8	Gray	8	Gray	8	Gold	0.1		
White	9	White	9	White	9				

Capacitors will be called out by their capacitance value in μF (microfarads) or pF (picofarads) and type: ceramic, Mylar*, electrolytic, etc. Some capacitors may have their value printed in the following manner:

EXAMPLES:

151K = $15 \times 10 = 150 pF$
 759 = $75 \times 0.1 = 7.5 pF$

NOTE: The letter "R" may be used at times to signify a decimal point: as in: 2R2 = 2.2 (pF or μF).

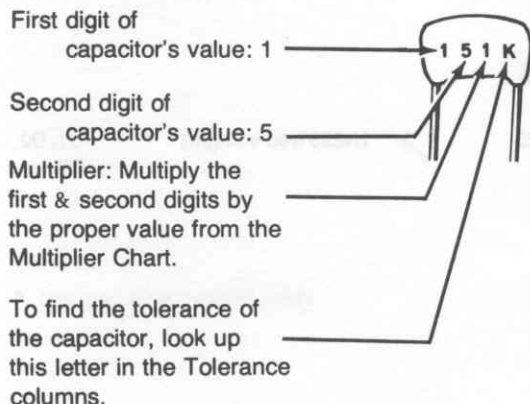

MULTIPLIER		TOLERANCE OF CAPACITOR		
FOR THE NUMBER:	MULTIPLY BY:	10 pF OR LESS	LETTER	OVER 10 pF
0	1	±0.1 pF	B	
1	10	±0.25 pF	C	
2	100	±0.5 pF	D	
3	1000	±1.0 pF	F	±1%
4	10,000	±2.0 pF	G	±2%
5	100,000		H	±3%
			J	±5%
8	0.01		K	±10%
9	0.1		M	±20%

*DuPont Registered Trademark

PARTS LIST

- () Unpack the kit and check each part against the following list. Return any part that is packed in an individual envelope, with the part number on it, back into its envelope until that part is called for in a step. Do not throw away any packing material until you account for all of the parts.

To order a replacement part, always include the PART NUMBER. Use the Parts Order Form furnished with this kit. If a Parts Order Form is not available, refer to "Replacement Parts" inside the rear cover of this Manual. For prices, refer to the separate "Heath Parts Price List."

TAPED COMPONENTS

Refer directly to the enclosed "Taped Component Chart." Follow the instructions at the top of that chart to check the following components.

HEATH QTY. DESCRIPTION
Part No. _____

CIRCUIT
Comp. No.

RESISTORS

NOTES:

- The following resistors are rated at 1/4-watt and have a tolerance of 5% unless otherwise listed. A 5% tolerance is indicated by a fourth color band of gold. 1% is indicated by a brown fifth color band.
- You will find that some of the Circuit Component Numbers are duplicated (they are beside two or more resistor values). The value you install depends upon the frequency range you intend to use.

HEATH Part No.	QTY.	DESCRIPTION	CIRCUIT Comp. No.
6-470-12	2	47 Ω (yel-viol-blk)	R3, R4
6-560-12	2	56 Ω (grn-blu-blk)	R3, R4

HEATH QTY. DESCRIPTION
Part No. _____

CIRCUIT
Comp. No.

Resistors (Cont'd).

6-101-12	1	100 Ω (brn-blk-brn)	R7
6-222-12	1	2200 Ω (red-red-red)	R2
6-332-12	1	3300 Ω (org-org-red)	R2
6-4991-12	1	4990 Ω, 1% (yel-wht-wht-brn)	R1
6-5491-12	1	5490 Ω, 1% (grn-yel-wht-brn)	R1
6-6341-12	1	6340 Ω, 1% (blu-org-yel-brn)	R1
6-2872-12	1	28.7 kΩ, 1% (red-gry-viol-red)	R8
6-3092-12	1	30.9 kΩ, 1% (org-blk-wht-red)	R8
6-4532-12	1	45.3 kΩ, 1% (yel-grn-org-red)	R8

DIODES

56-20	3	1N295 (red-wht-grn)	D1, D2, D3
-------	---	---------------------	------------

NON-TAPED PARTS

The following parts are not taped on strips. The key numbers correspond to the numbers on the "Parts Pictorial" (Illustration Booklet, Page 1).

KEY HEATH	QTY.	DESCRIPTION	CIRCUIT
No.	Part No.		Comp. No.

CAPACITORS — TRIMMER

NOTE: You will find that some of the Circuit Component Numbers are duplicated (they are beside two or more capacitor values). The value you install depends upon the frequency range you intend to use.

Mica

A1	20-52	1	7.5 pF	C2
A1	20-100	2	30 pF	C5, C6
A1	20-102	2	100 pF	C7, C8
A1	20-172	2	1000 pF	C7, C8

Ceramic

A2	21-181	1	7.7 pF	C3
A2	21-11	2	150 pF	C5, C6
A2	21-140	1	.001 μ F (1000 pF)	C11, C12, C13, C14, C15, C16, C17
A2	21-27	2	.005 μ F (5000 pF)	C9, C18

Other Capacitors

A3	28-3	1	.56 pF phenolic (grn-blu-gry-silv)	C1
A4	31-57	1	2.7–20 pF trimmer	C4

KEY HEATH	QTY.	DESCRIPTION	CIRCUIT
No.	Part No.		Comp. No.

HARDWARE

NOTE: Hardware packets are marked to show the size of the hardware they contain (HDW#4, or HDW#6, etc.). You may have to open more than one packet to locate all of the hardware of any one size (#6, for example).

#6 Hardware

B1	250-1282	1	6-32 \times 1/8" setscrew
B2	250-230	1	6-32 \times 3/16" setscrew
B3	250-1307	4	#6 \times 1/4" sheet metal screw
B4	250-1280	2	6-32 \times 3/8" screw
B5	250-1246	3	6-32 \times 1-1/4" screw
B6	252-3	8	6-32 nut
B7	253-1	1	#6 fiber flat washer
B8	254-1	8	#6 lockwasher

Other Hardware

C1	252-7	2	Control nut
C2	253-10	2	Control flat washer
C3	255-5	3	3/4" long spacer
C4	257-12	1	Eyelet
C5	259-10	1	Control solder lug

CONTROLS — SWITCHES

D1	10-325	1	50 k Ω control	R6
D2	19-153	1	200 k Ω control with switch	R9/S1
D3	63-1398	1	Rotary switch	S2

KEY No.	HEATH Part No.	QTY.	DESCRIPTION	CIRCUIT Comp. No.
---------	----------------	------	-------------	-------------------

SHEET METAL PARTS

E1	90-1293-1	1	Cabinet	
E2	200-1433-1	1	Chassis	
E3	204-2375	1	Meter bracket	

WIRE — SLEEVING

340-3	3"	Bare wire
344-144	9"	Blue wire
346-21	3"	Sleeving
347-55	12"	8-wire cable

KEY No.	HEATH Part No.	QTY.	DESCRIPTION	CIRCUIT Comp. No.
---------	----------------	------	-------------	-------------------

MISCELLANEOUS

F1	40-1970	1	29.5 μ H toroid coil	L1
F1	40-1982	1	6 μ H toroid coil	L1
F2	73-147	3"	Foam tape	
	85-2786-1	1	Circuit board	
F3	205-778	1	Steel blade	
F4	261-29	4	Foot	
F5	354-5	2	Cable tie	
F6	390-2550	1	Front panel label*	
F7		1	Blue and white label*	
F8	407-762	1	Meter	M1
F9	432-120	1	PCB socket	
F10	432-121	3	PCB pin	
F11	436-51	2	Coaxial socket	J1, J2
F12	462-1151	2	Knob	
F13	475-10	7	Ferrite bead	L2, L3, L4, L5, L6, L7, L8
F14	490-5	1	Nut starter	
		1	Assembly Manual (See Page 1 for part number.)	
	597-260	1	Parts Order Form*	
			Solder	

* These items may be packed inside the Manual.

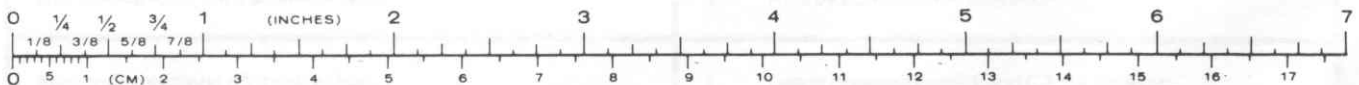

STEP-BY-STEP ASSEMBLY

CIRCUIT BOARD ASSEMBLY

START

NOTE: Refer to the "Taped Components Chart" before you begin.

In the following steps, you will be given detailed instructions on how to install and solder the first part on the circuit board. Read and perform each step carefully. Then use the same procedure whenever you install parts on a circuit board.

Position the circuit board as shown with the printed side (not the foil side) up.

NOTE: When you install a component that has its value printed on it, position the value marking up, so it can be easily read. Diodes should be mounted with their type or part number up, if possible.

Hold a 100 Ω (brn-blk-brn) resistor with long-nose pliers and bend the leads straight down to fit the hole spacing on the circuit board.



R7: Push the leads through the holes at the indicated location on the circuit board. The end with color bands may be positioned either way.

Press the resistor against the circuit board. Then bend the leads outward slightly to hold the resistor in place.

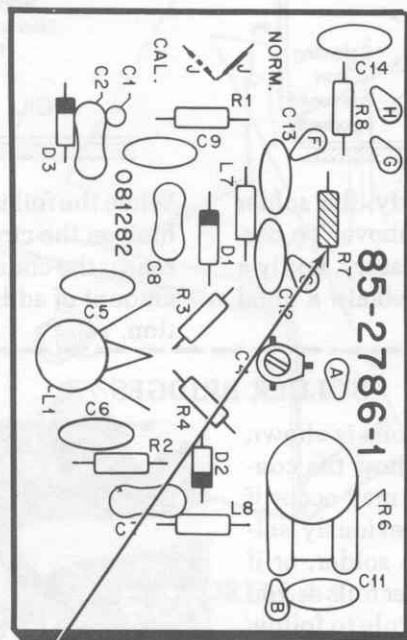
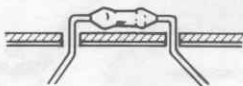

PICTORIAL 1-1

CONTINUE

Solder the resistor leads to the circuit board as follows:

1. Push the soldering iron tip against both the lead and the circuit board foil. Heat both for two or three seconds.

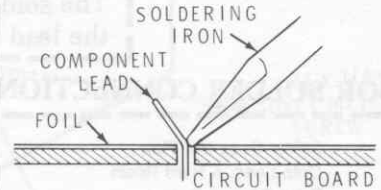

2. Then apply solder to the other side of the connection. **IMPORTANT:** Let the heated lead and the circuit board foil melt the solder.

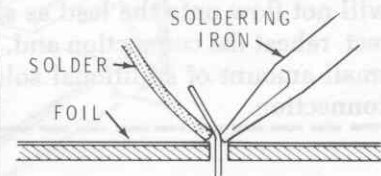

3. As the solder begins to melt, allow it to flow around the connection. Then remove the solder and the iron and let the connection cool.

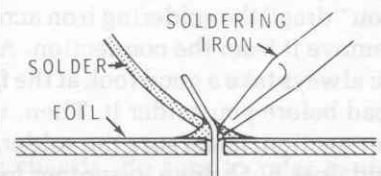

Cut off the excess lead lengths close to the connection. **WARNING:** Clip the leads so the ends will not fly toward your eyes.

Check each connection. Compare it to the illustrations on Page 10. After you have checked the solder connections, proceed with the assembly on Page 11. Use the same soldering procedure for each connection.

A GOOD SOLDER CONNECTION

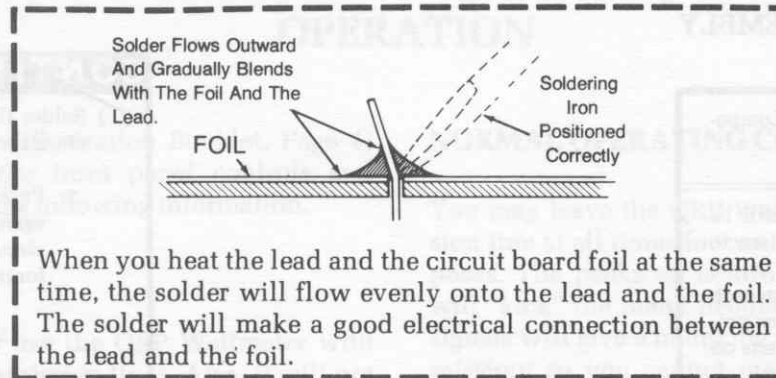

POOR SOLDER CONNECTIONS

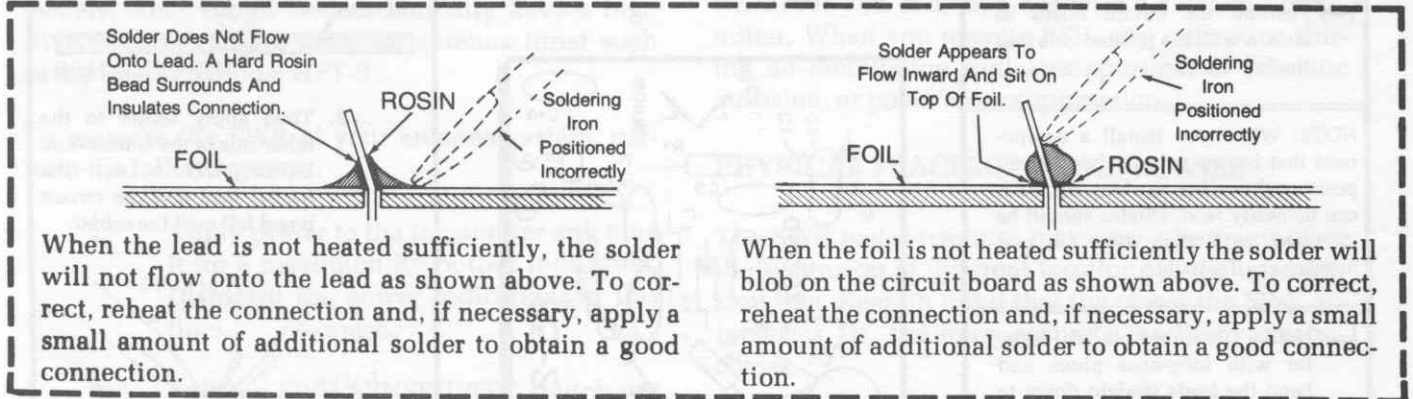

SOLDER BRIDGES

A solder bridge between two adjacent foils is shown in photograph A. Photograph B shows how the connection should appear. A solder bridge may occur if you accidentally touch an adjacent previously soldered connection, if you use too much solder, or if you "drag" the soldering iron across other foils as you remove it from the connection. A good rule to follow is: always take a good look at the foil area around each lead before you solder it. Then, when you solder the connection, make sure the solder remains in this area and does not bridge to another foil. This is especially important when the foils are small and close together. NOTE: It is alright for solder to bridge two connections on the same foil.

Use only enough solder to make a good connection, and lift the soldering iron straight up from the circuit board. If a solder bridge should develop, turn the circuit board foil-side-down and heat the solder between connections. The excess solder will run onto the tip of the soldering iron, and this will remove the solder bridge. NOTE: The foil side of most circuit boards has a coating on it called "solder resist." This is a protective insulation to help prevent solder bridges.

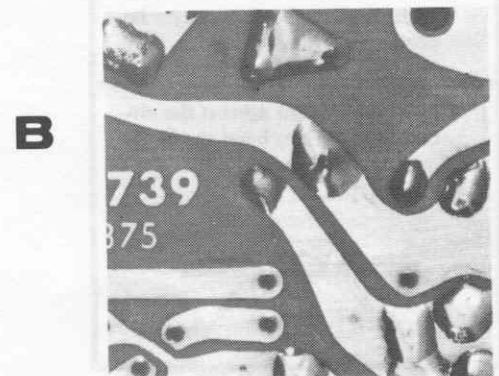
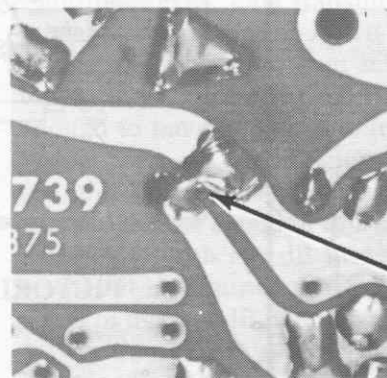

START

(✓) Be sure you installed resistor R7 in Pictorial 1-1.

NOTE: This Wattmeter may be constructed to operate on any one of the following frequency ranges:

1.8 to 30 MHz

50 to 54 MHz

144 to 148 MHz

(✓) Decide which frequency range you intend to use. Then write this range on the following line
1.8 to 30 MHz

NOTE: In many of the following steps, you will be given a table of values instead of a specific value. Always use the value that corresponds to the frequency range that you wrote on the line in the above step.

(✓) R1: Resistor.

1.8-30 MHz: 6340 Ω, 1% (blu-org-yel-brn).

50-54 MHz: 4990 Ω, 1% (yel-wht-wht-brn).

144-148 MHz: 5490 Ω, 1% (grn-yel-wht-brn).

() R2: Resistor.

1.8-30 MHz: 3300 Ω (org-org-red).

50-54 MHz: 2200 Ω (red-red-red).

144-148 MHz: 2200 Ω (red-red-red).

(✓) Solder the leads to the foil and cut off the excess lead lengths.

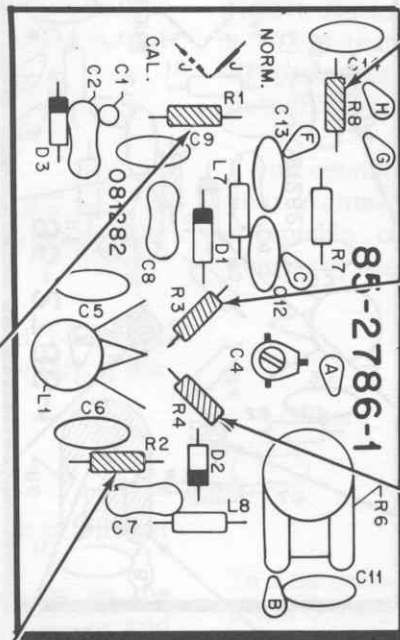

PICTORIAL 1-2

CONTINUE

(✓) R8: Resistor.

1.8-30 MHz: 45.3 kΩ, 1% (yel-grn-org-red).

50-54 MHz: 28.7 kΩ, 1% (red-gry-viol-red).

144-148 MHz: 30.9 kΩ, 1% (org-blk-wht-red).

(✓) R3: Resistor.

1.8-30 MHz: 47 Ω (yel-viol-blk).

50-54 MHz: 56 Ω (grn-blu-blk).

144-148 MHz: 56 Ω (grn-blu-blk).

(✓) R4: Resistor.

1.8-30 MHz: 47 Ω (yel-viol-blk).

50-54 MHz: 56 Ω (grn-blu-blk).

144-148 MHz: 56 Ω (grn-blu-blk).

(✓) Solder the leads to the foil and cut off the excess lead lengths.

START ↘

NOTE: When you install a diode, always match the band on the diode with the band mark on the circuit board. **THE CIRCUIT WILL NOT WORK PROPERLY IF IT IS INSTALLED BACKWARDS.** See Detail 1-3A.

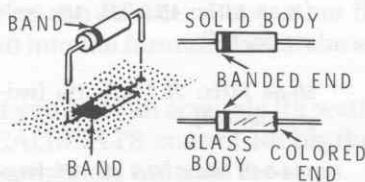

If your diode has a solid body, the band is clearly defined. If your diode has a glass body, do not mistake the colored end inside the diode for the banded end. Look for a band painted on the outside of the glass.

Install three 1N295 diodes (#56-20, red-wht-grn) at the following locations:

- D3
- D1
- D2

Solder the leads to the foil and cut off the excess lead lengths.

R6: 50 kΩ control (#10-325). Push the control firmly down onto the board; then solder all its lugs to the foil.

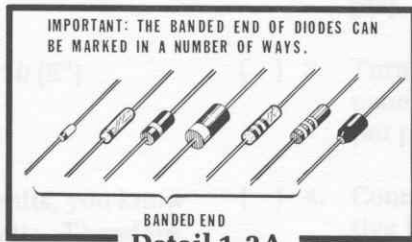

Detail 1-3A

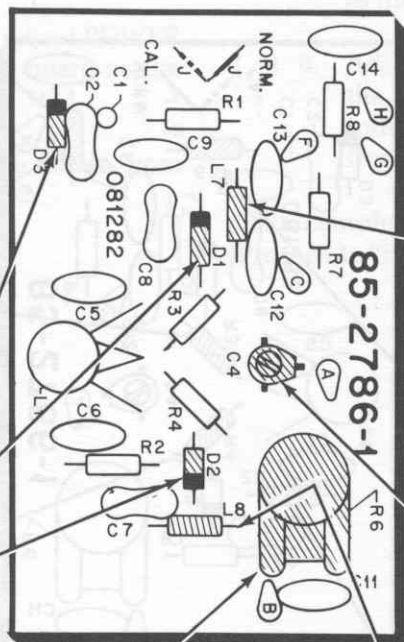

PICTORIAL 1-3

CONTINUE ↘

Locate a .005 μF ceramic capacitor. Then cut the leads to 1/4". Set the capacitor aside for use in Pictorial 1-4. Save the cutoff leads for use in the following steps.

NOTE: When a step calls for a ferrite bead, use a cutoff component lead as shown.

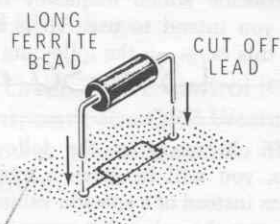

L7: Ferrite bead.

C4: 2.7-20 pF trimmer. Align its flat with the flat outline on the circuit board and insert the pins of the trimmer into their circuit board holes. Press the shoulders of the pins against the board and solder the pins to the foil.

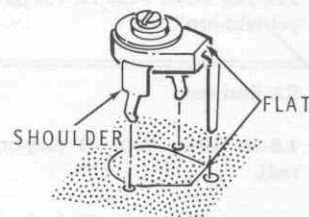

L8: Ferrite bead.

Solder the leads to the foil and cut off the excess lead lengths.



START

NOTE: When you install ceramic capacitors, do not push the insulated portion of the leads into the circuit board holes. This could make it difficult to solder the leads to the foil.

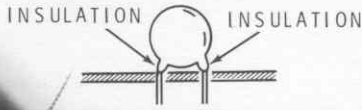

C2: Capacitor.

1.8-30 MHz: 100 pF mica.

50-54 MHz: 7.5 pF mica.

144-148 MHz: 7.5 pF mica.

C9: .005 μ F ceramic. Use the capacitor that has the shortened leads.

C8: Capacitor.

1.8-30 MHz: 1000 pF mica.

50-54 MHz: 100 pF mica.

144-148 MHz: 100 pF mica.

C5: Capacitor.

1.8-30 MHz: 150 pF ceramic.

50-54 MHz: 30 pF mica.

144-148 MHz: 30 pF mica.

C6: Capacitor.

1.8-30 MHz: 150 pF ceramic.

50-54 MHz: 30 pF mica.

144-148 MHz: 30 pF mica.

C7: Capacitor.

1.8-30 MHz: 1000 pF mica.

50-54 MHz: 100 pF mica.

144-148 MHz: 100 pF mica.

Solder the leads to the foil and cut off the excess lead lengths.

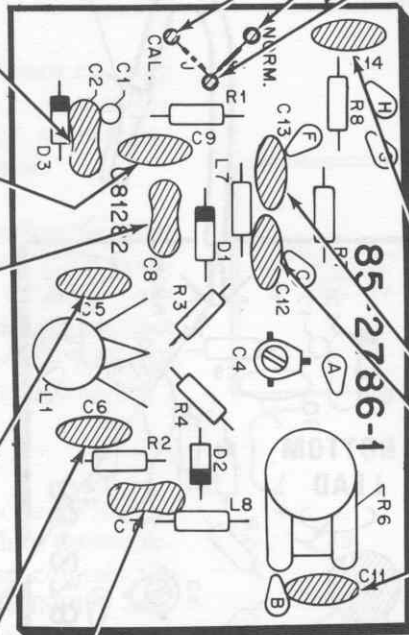

PICTORIAL 1-4

CONTINUE

NOTE: When you are instructed to install PCB pins, install them as shown and solder them to the foil.

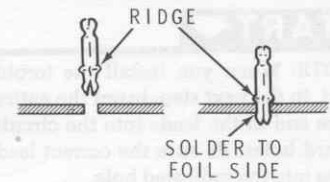

PCB pin at CAL.

PCB pin at NORM.

PCB pin at the indicated location. NOTE: Try not to fill this pin with solder. You will solder a wire end in it in a later step.

Install four .001 μ F (1000 pF) ceramic capacitors at the following locations:

C14.

C13.

C12.

C11.

Solder the leads to the foil and cut off the excess lead lengths.

START ↘

NOTE: When you install the toroid coil, in the next step, insert the entire bare end of the leads into the circuit board holes. Be sure the correct lead goes into the indicated hole.

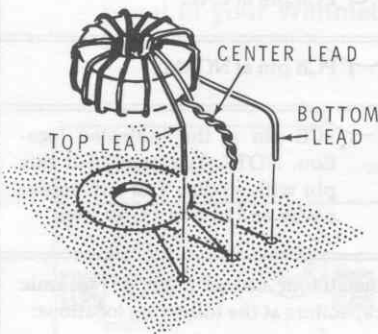

() L1: Toroid coil. Do not solder the leads to the foil yet.

1.8-30 MHz: 29.5 μ H (#40-1970).

50-54 MHz: 6 μ H (#40-1982).

144-148 MHz: 6 μ H (#40-1982).

() Place a #6 fiber flat washer over the eyelet as shown. Then insert the eyelet through coil L1 from the component side of the circuit board. Solder the eyelet to the foil. Do not fill the eyelet with solder. Then solder the leads of the toroid coil to the foil and cut off the excess lengths.

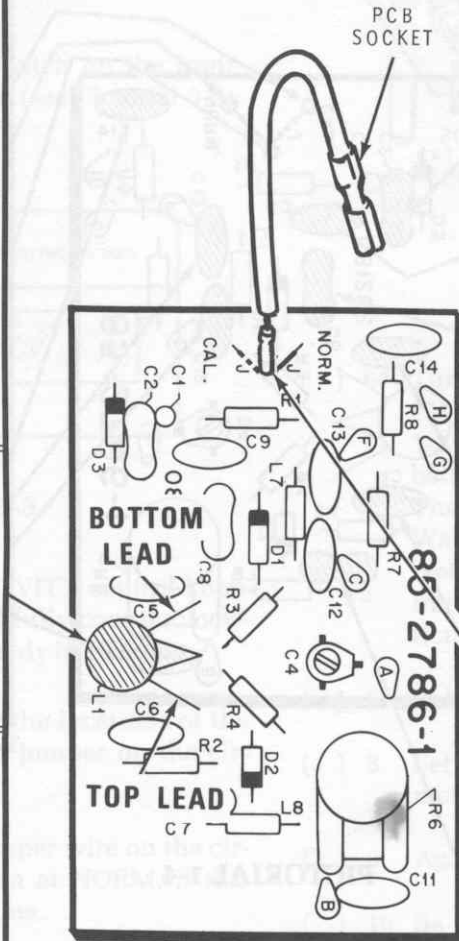
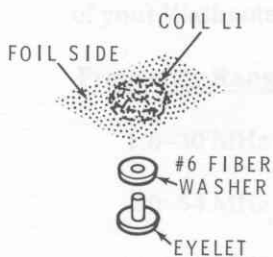

CONTINUE ↘

NOTE: When you are directed to prepare a stranded wire, first cut the wire to the indicated length and remove 1/4" of insulation from each end of the wire. Twist the fine strands at each end tightly together. Then melt a small amount of solder on these ends to hold the strands together.

() Prepare a 1-1/2" blue wire. Then solder a PCB socket on one end of the wire as shown.

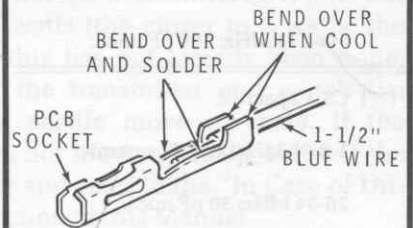

() Insert the free end of the wire into the indicated PCB pin and solder the connection. The PCB socket will be connected later.

PICTORIAL 1-5

Heathkit®

Refer to Pictorial 1-6 (Illustration Booklet, Page 2) for the following steps.

NOTE: When you separate the wires of the 8-wire cable in the next step, discard the blue wire of the cable. It is very important that you do **not** use this blue cable wire to wire the kit (a separate special blue wire for this purpose is supplied with the kit).

(✓) Separate the 8-wire cable into eight separate wires. Be sure to discard the blue wire. Use the remaining wires whenever a step calls for wire.

(✓) Prepare the following wires:

6" yellow

5" green

5" brown

5" red

5-1/2" gray

(✓) Remove an additional 1/4" of insulation (total 1/2") from one end of the 6" yellow wire. Then refer to Detail 1-6A and slide a ferrite bead onto this end of the wire. Push the end of the wire into circuit board hole B until the ferrite

bead is down against the component side of the circuit board. Solder the wire to the foil and cut off any excess length on the foil side of the circuit board.

Similarly, remove an additional 1/4" length of insulation from one end of the remaining prepared wires and slide a ferrite bead onto this end of each wire. Then solder this end of the wires to the circuit board holes as follows:

(✓) 5" green wire and bead in hole C.

(✓) 5" brown wire and bead in hole F.

(✓) 5" red wire and bead in hole G.

(✓) 5-1/2" gray wire and bead in hole H.

(✓) C1: Select the correct capacitor value from the list below. Then cut one lead of this capacitor to 1-3/8" and the other lead to 1/4". Solder the shorter capacitor lead to circuit board hole C1. Be sure to keep this lead as short as possible. The longer lead will be connected later.

1.8–30 MHz: 7.7 pF ceramic

50–54 MHz: .56 pF phenolic
(grn-blu-gry-silv)

144–148 MHz: .56 pF phenolic
(grn-blu-gry-silv)

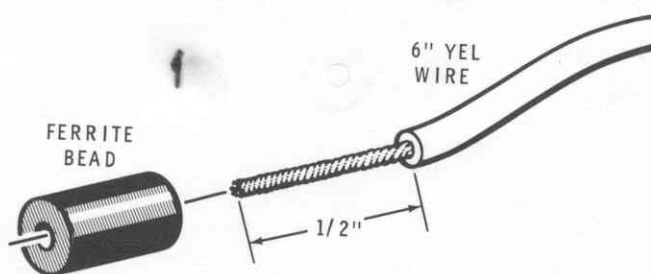

Detail 1-6A

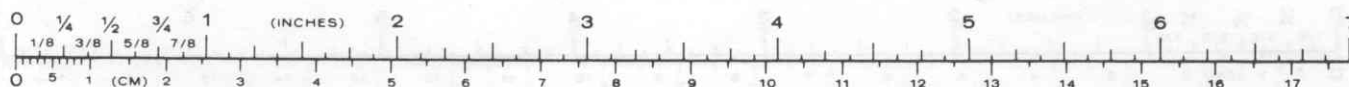

() C3: Select the correct capacitor value from the list below, Then cut one lead of the capacitor to 1-1/4" and the other lead to 1/2". Turn the circuit board foil side up as shown in Pictorial 1-7 and solder the shorter lead of this capacitor to circuit board hole A. Be sure to space the capacitor body 1/4" above the circuit board. The longer lead will be connected later. NOTE: Hole A is labeled on the component side of the circuit board.

1.8–30 MHz: 100 pF mica

50–54 MHz: 7.7 pF ceramic

144–148 MHz: 7.7 pF ceramic

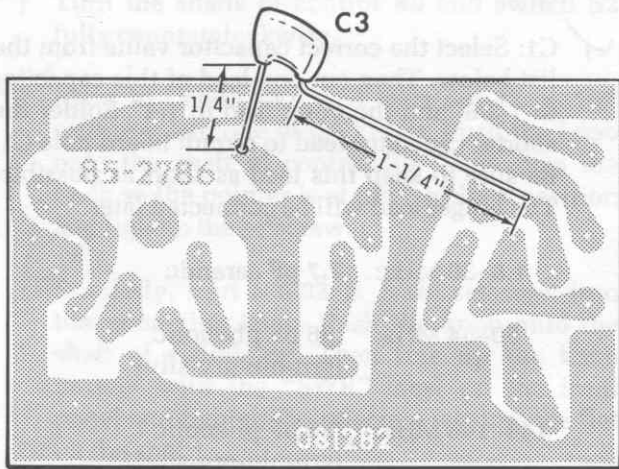

PICTORIAL 1-7

CIRCUIT BOARD CHECKOUT

Carefully inspect the circuit board for the following conditions:

- () Unsoldered connections. NOTE: There are five unused holes in the circuit board.
- () Poor solder connections.
- () Solder bridges between foil patterns.
- () Protruding leads which could touch together.
- () Diodes for the correct position of the banded end.
- () Toroid coil for the correct connection of the leads.

Set the circuit board aside until it is called for in a step.

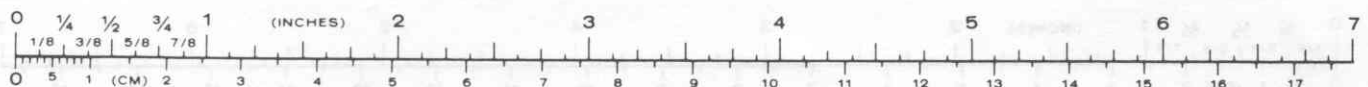
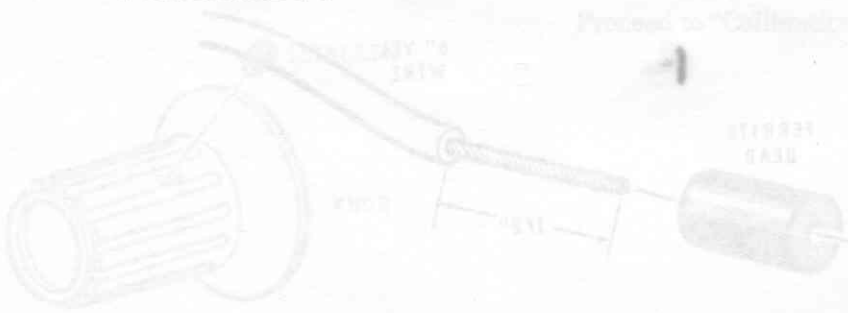

Heathkit®

CHASSIS ASSEMBLY

Refer to Pictorial 2-1 (Illustration Booklet, Page 2) for the following steps.

- 1) Refer to Detail 2-1A and use sandpaper or a knife to scrape away any excess paint from the areas shown. The hardware that you will mount at these locations require a good contact with the metal chassis.

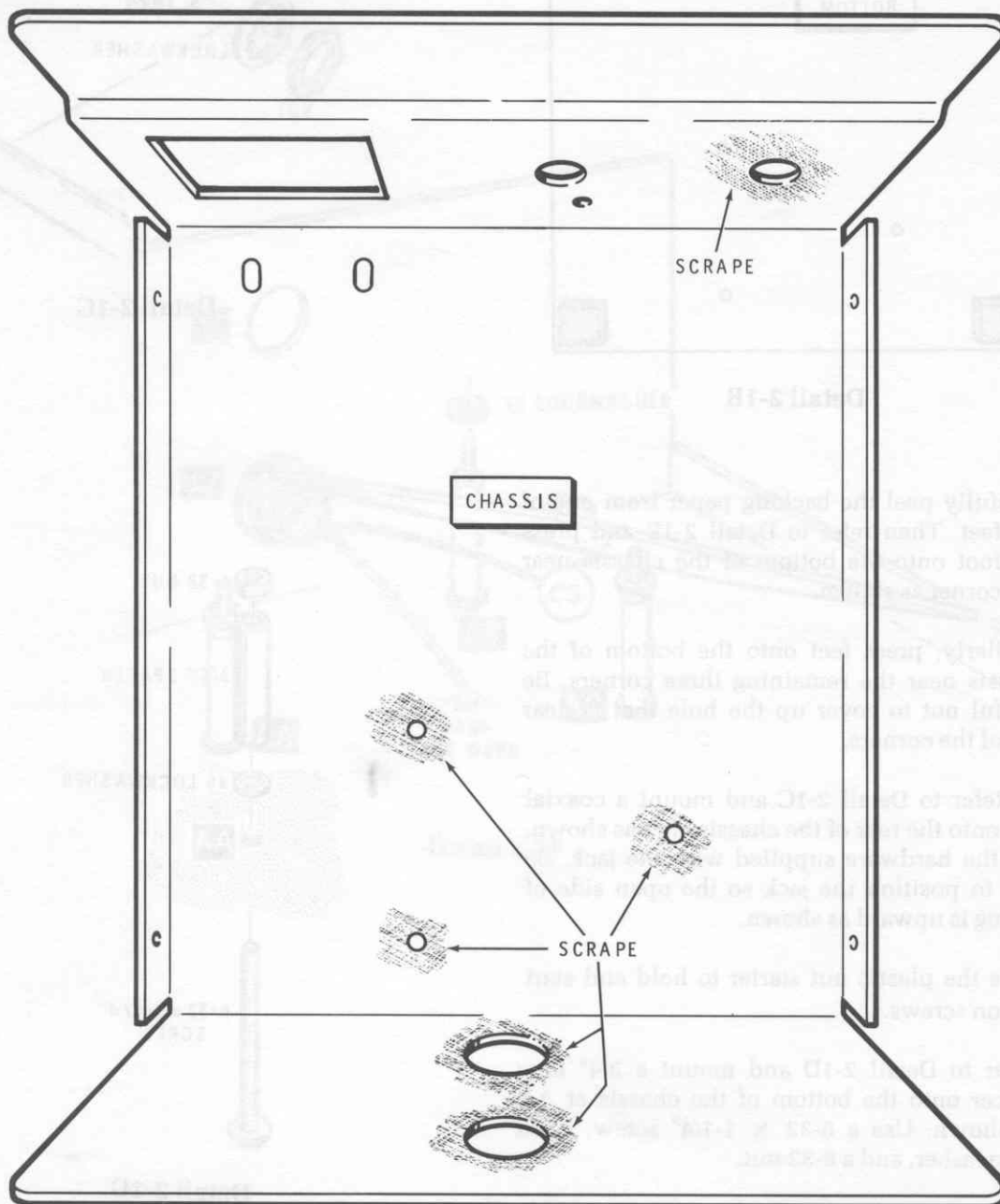

Detail 2-1A

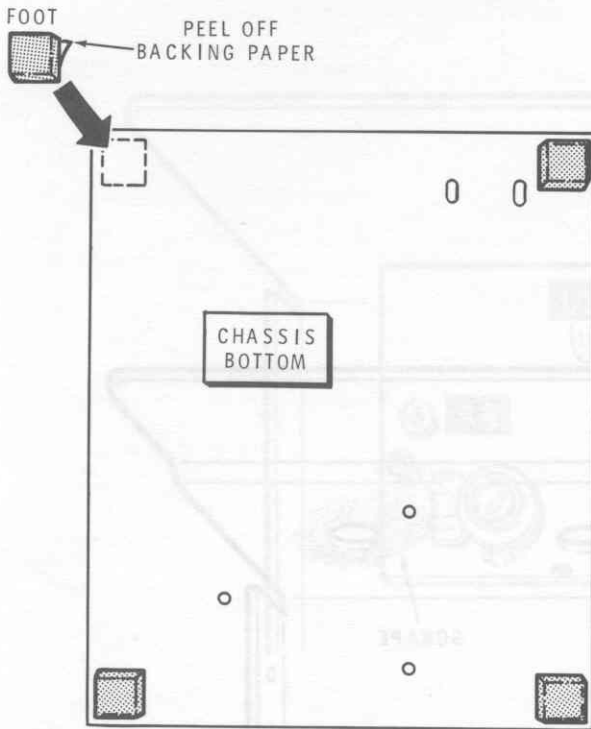

Detail 2-1B

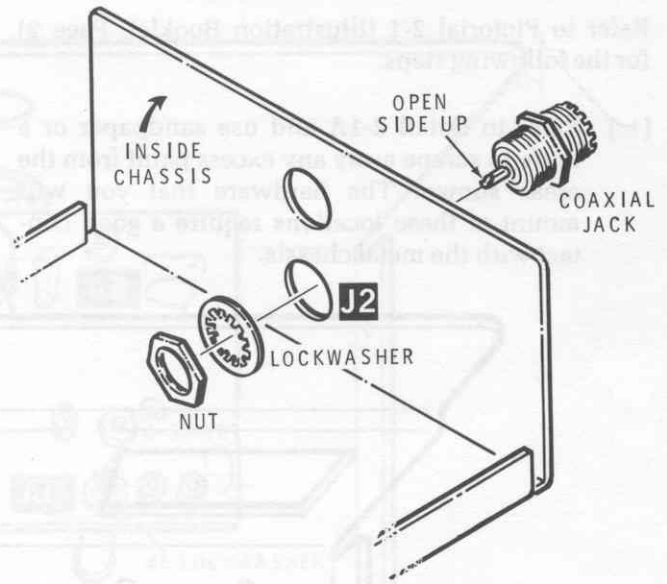

Detail 2-1C

- (✓) Carefully peel the backing paper from one of the feet. Then refer to Detail 2-1B and press the foot onto the bottom of the chassis near one corner as shown.
- (✓) Similarly, press feet onto the bottom of the chassis near the remaining three corners. Be careful not to cover up the hole that is near one of the corners.
- (✓) J2: Refer to Detail 2-1C and mount a coaxial jack onto the rear of the chassis at J2 as shown. Use the hardware supplied with the jack. Be sure to position the jack so the open side of the lug is upward as shown.

NOTE: Use the plastic nut starter to hold and start 6-32 nuts on screws.

- (✓) Refer to Detail 2-1D and mount a 3/4" long spacer onto the bottom of the chassis at AA as shown. Use a 6-32 x 1-1/4" screw, a #6 lockwasher, and a 6-32 nut.
- (✓) Similarly, mount 3/4" long spacers onto the bottom of the chassis at AB and AC.

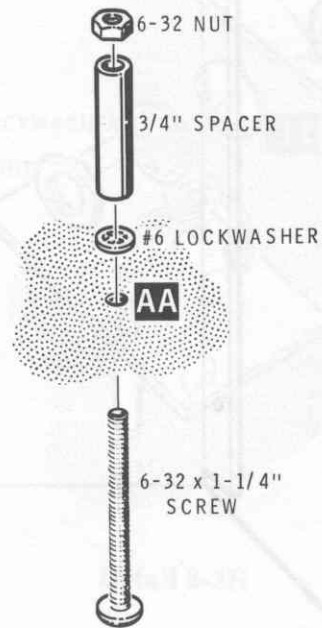

Detail 2-1D

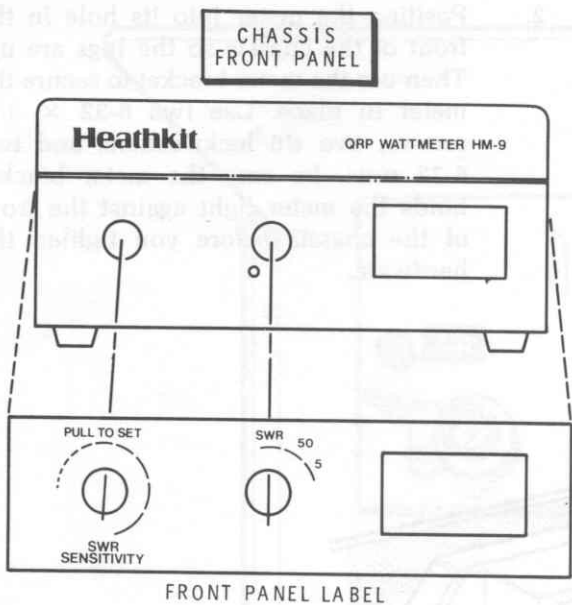

CHASSIS FRONT PANEL

FRONT PANEL LABEL

Detail 2-1E

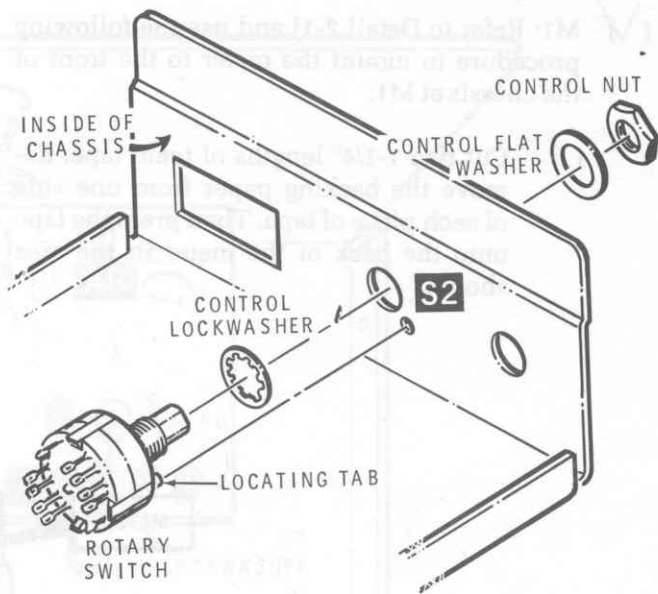

Detail 2-1G

- (✓) Carefully peel the backing paper from the front panel label. Then refer to Detail 2-1E and line up the holes in the label with the holes in the front of the chassis and press the label into place.
- (✓) Turn the shaft of the rotary switch fully counterclockwise. Then remove the hardware from the bushing of the rotary switch. Now refer to Detail 2-1F and reinstall the detent ring so its tab is in slot #3. NOTE: Be sure the detent ring tab stays at this position when you perform the next step.

- (✓) S2: Refer to Detail 2-1G and mount the rotary switch to the front of the chassis at S2 as shown. Use the control lockwasher (supplied with the switch), a control flat washer, and a control nut (supplied with the switch). Be sure the locating tab on the switch enters its corresponding hole in the chassis. NOTE: Do not overtighten the nut.
- (✓) R9/S1: Refer to Detail 2-1H (Illustration Booklet, Page 2) and use the following procedure to mount the 200 kΩ control with switch (#19-153) to the front of the chassis at R9/S1:

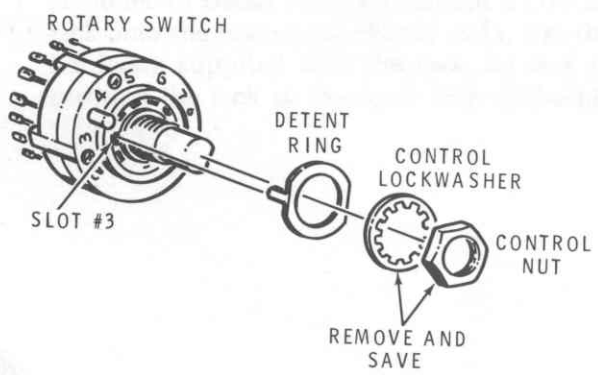

Detail 2-1F

1. Locate the control solder lug. Then reform the bend in the lug to 90° as shown in the inset drawing.
2. Turn a control nut all the way onto the bushing of the control with switch. Then mount the control with switch and the prepared control solder lug onto the front of the chassis at R9/S1 as shown. Use a control flat washer and a control nut. Be sure to position the control with switch and the control solder lug as shown in the Pictorial before you tighten the nut. NOTE: The bend in the solder lug must be 1/4" below the lip in the front of the chassis.

(✓) M1: Refer to Detail 2-1J and use the following procedure to mount the meter to the front of the chassis at M1:

1. Cut two 1-1/4" lengths of foam tape. Remove the backing paper from one side of each piece of tape. Then press the tape onto the back of the meter in the area shown.

2. Position the meter into its hole in the front of the chassis so the lugs are up. Then use the meter bracket to secure the meter in place. Use two 6-32 × 3/8" screws, two #6 lockwashers, and two 6-32 nuts. Be sure the meter bracket holds the meter tight against the front of the chassis before you tighten the hardware.

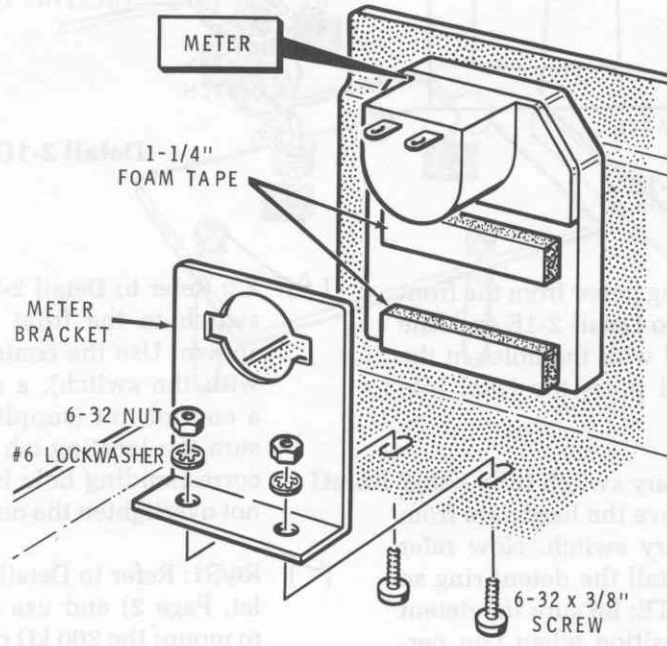

Detail 2-1J

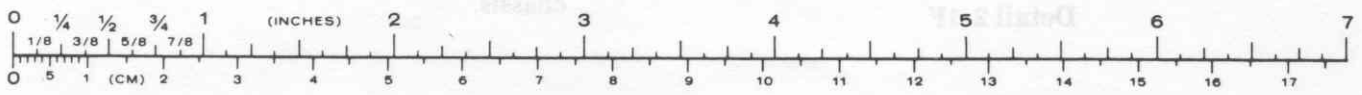

Heathkit®

Refer to Pictorial 2-2 for the following steps.

Prepare the following wires:

4" red

3" green

4" gray

NOTE: In the following steps, (NS) means not to solder the connection because you will add other wires later. "S-" with a number, such as (S-2), means to solder the connection. The number following the "S-" tells you how many wires should be at the connection. This helps you check your work for errors as you go.

Connect one end of a 4" red wire to switch S2 lug 1 (NS). Route the free end of the wire as shown; it will be connected later.

Remove any fine wire that may be wrapped around the lugs of meter M1. Then connect a 3" green wire from meter M1 lug 2 (NS) to switch S2 lug A (S-1).

Remove an additional 1/4" of insulation (total 1/2") from one end of a 4" gray wire. Then wrap this end of the wire around the control solder

lug coming from R9/S1 in the area shown (NS). Connect the free end of this wire to meter M1 lug 1 (NS).

C18: Cut both leads of a .005 μF ceramic capacitor to 1/2". Then connect the capacitor between meter M1 lugs 1 (S-2) and 2 (S-2).

NOTE: When you connect the capacitor leads to the control solder lug in the following steps, wrap each lead around the lug near the gray wire that comes from meter M1.

C17: Cut one lead of a .001 μF (1000 pF) ceramic capacitor to 1/2" and the other lead to 1". Then connect the shorter lead to switch S2 lug 1 (S-2) and the longer lead to the control solder lug (NS).

C16: Cut one lead of a .001 μF (1000 pF) ceramic capacitor to 1/4" and the other lead to 3/4". Then connect the shorter lead to switch S2 lug 2 (NS) and the longer lead to the control solder lug (NS).

C15: Cut one lead of a .001 μF (1000 pF) ceramic capacitor to 1/4" and the other lead to 1/2". Then connect the shorter lead to switch S2 lug 3 (NS) and the longer lead to the control solder lug (NS).

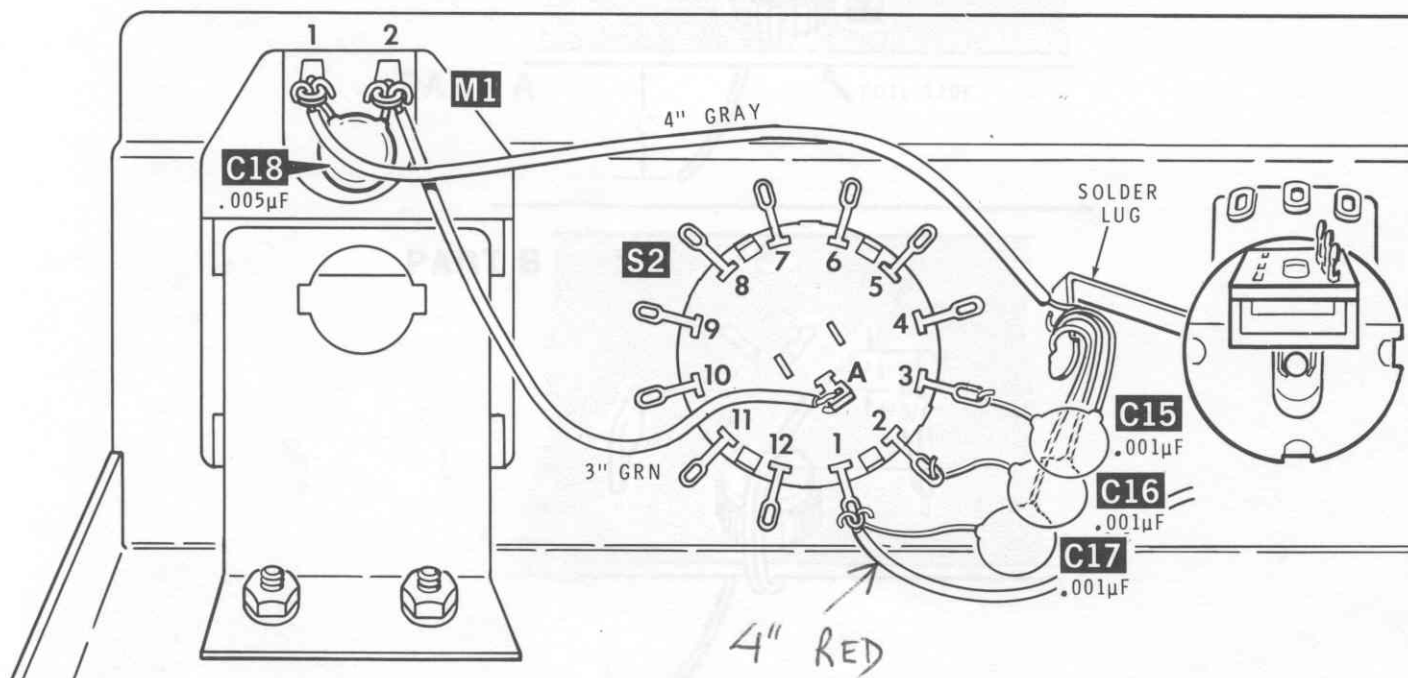

PICTORIAL 2-2

Refer to Pictorial 2-3 (Illustration Booklet, Page 3) for the following steps.

- () Connect the free end of the red wire coming from switch S2 to control R9 lug 3 (S-1).
- () Prepare a 1-1/4" brown wire. Then connect the wire from control R9 lug 2 (S-1) to switch S1 lug 5 (S-1). NOTE: There are no lugs 1, 2, or 3 on switch S1.

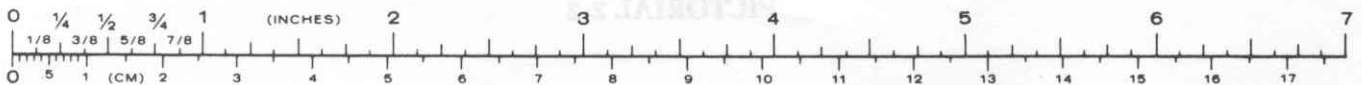

NOTE: In the following steps, (MS) means not to solder the connection because you will add other wires later. "S" with a number, such as (S-2), means to solder the connection. The number following the "S" tells you how many wires should be at the connection. This helps you check your work for errors as you go.

Remove any fine wire that may be wrapped around the lugs of motor M1. Then connect a 3' green wire from motor M1 lug 2 (MS) to switch S1 lug A (S-1).

Remove an additional 1/4" of insulation from the end of the wire around the control solder lug 1 (MS). Route the free end of the wire as shown. It will be connected later.

Connect one end of a 4' red wire to switch S2 lug 1 (MS). Route the free end of the wire as shown. It will be connected later.

C15: Cut one lead of a .001 μf (1000 pf) ceramic capacitor to 1/4" and the other lead to 1/2". Then connect the shorter lead to switch S1 lug 2 (MS) and the longer lead to the control solder lug (MS).

C16: Cut one lead of a .001 μf (1000 pf) ceramic capacitor to 1/4" and the other lead to 1/2". Then connect the shorter lead to switch S2 lug 2 (MS) and the longer lead to the control solder lug (MS).

C17: Cut one lead of a .001 μf (1000 pf) ceramic capacitor to 1/4" and the other lead to 1/2". Then connect the shorter lead to switch S1 lug 1 (MS) and the longer lead to the control solder lug (MS).

Heathkit®

The following pages give instructions for each of the optional frequency ranges for this instrument. Proceed with only the steps for the frequency range you selected for your Wattmeter.

1.8–30 MHz Model

NOTE: Perform the following steps only if you are assembling your Wattmeter to cover the 1.8–30 MHz range.

() Cut a 5" length of blue wire. Be sure to use the special blue wire that was supplied with the kit. Do not remove the insulation from the ends of the wire yet.

() Refer to Detail 2-3A Part A and push one end of the 5" blue wire through the eyelet at L1 on the circuit board. Position the wire so 1" extends from the eyelet on the foil side of the circuit board.

() Refer to Part B of the Detail and wind the wire around the nearby edge of the circuit board and up through the eyelet. Continue winding the wire until you have two loops of wire around the edge of the circuit board. Be sure to pull each winding tight.

() Cut off the free ends of the wire at a point $\frac{5}{8}$ " away from the eyelet on each side of the circuit board. Then remove $\frac{1}{4}$ " of insulation from each end of the blue wire and prepare the ends.

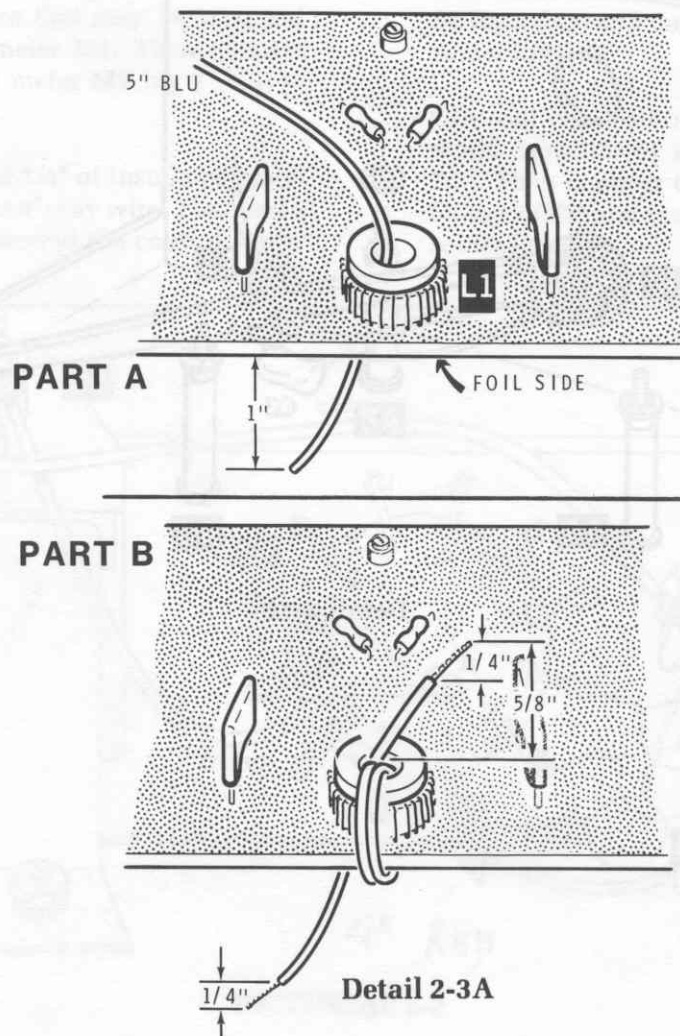

- (/) Refer to Detail 2-3B and position the circuit board into the chassis so it is near coaxial jack J2 as shown.
- (/) Refer again to Detail 2-3B and position the free end of the blue wire, coming from the eyelet at L1 on the foil side of the circuit board, into the hole in the lug of coaxial jack J2. Also position the free end of the lead of capacitor C3, coming from hole A of the circuit board, into the hole in the lug of coaxial jack J2. Now solder the connection.

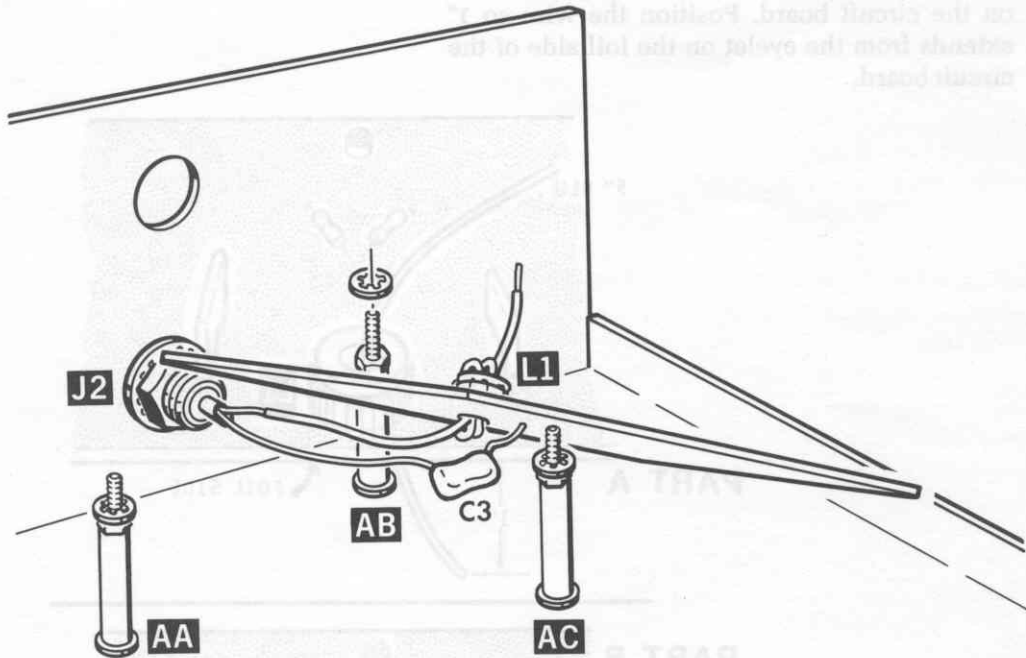

Detail 2-3B

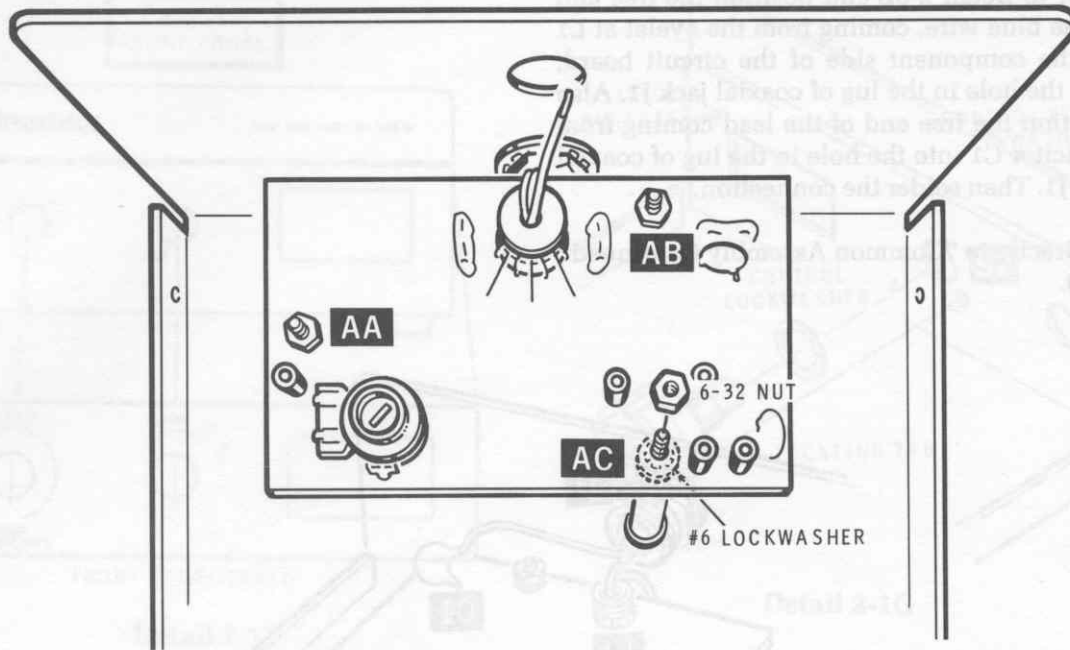

Detail 2-3C

- (1) Place a #6 lockwasher onto each of the screws coming from spacers AA, AB, and AC. Then refer to Detail 2-3C and position the circuit board down onto the screws. Use three 6-32 nuts to secure the circuit board at AA, AB, and AC.
- (2) Look between the circuit board and the chassis. Make sure the longer lead of capacitor C3 is not touching the chassis or the circuit board. Reposition the capacitor lead as necessary.
- (3) J1: Refer to Detail 2-3D and mount a coaxial jack onto the rear of the chassis as J1. Use the hardware supplied with the jack. Be sure to position the jack so the open side of the lug is upward.

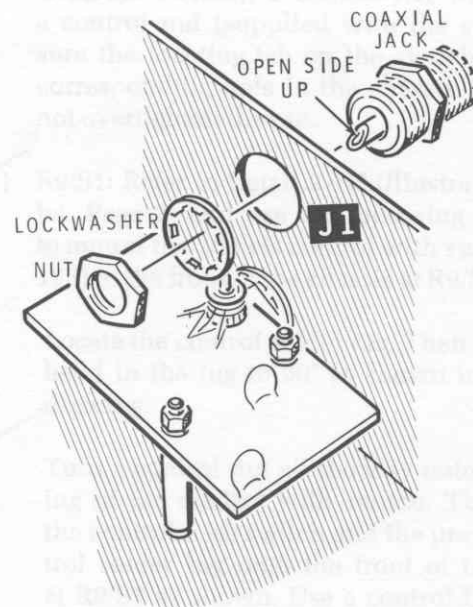

Detail 2-3D

- () Refer to Detail 2-3E and position the free end of the blue wire, coming from the eyelet at L1 on the component side of the circuit board, into the hole in the lug of coaxial jack J1. Also position the free end of the lead coming from capacitor C1 into the hole in the lug of coaxial jack J1. Then solder the connection.

Proceed directly to "Common Assembly Continued" on Page 29.

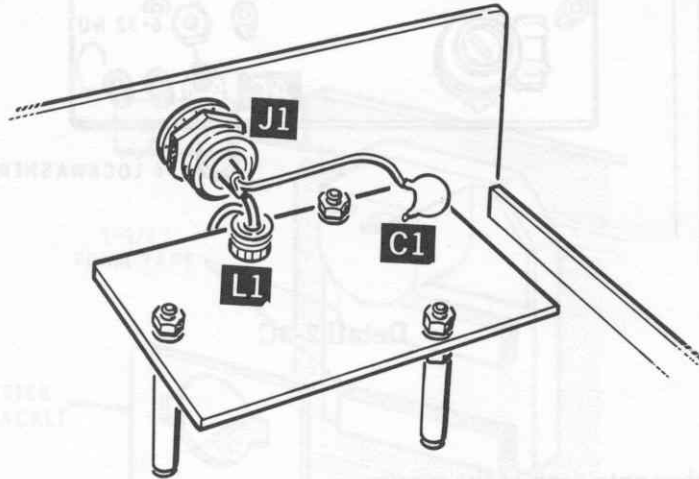

Detail 2-3E



Heathkit®

50-54 and 144-148 MHz Models

NOTE: Perform the following steps only if you are assembling your Wattmeter to cover the 50-54 or 144-148 MHz ranges.

- () Cut a 1-3/4" large bare wire.
- () Refer to Detail 2-3F and position the circuit board into the chassis so it is between the spacers at AA, AB, and AC as shown.
- () Position one end of the 1-3/4" large bare wire into the hole in the lug of coaxial jack J2. Also position the free end of the lead of capacitor C3, coming from hole A of the circuit board, into the hole in the lug of coaxial jack J2. Then solder the connection.
- () Bend the large bare wire coming from coaxial jack J2 straight up so it is toward hole J1 in the chassis.

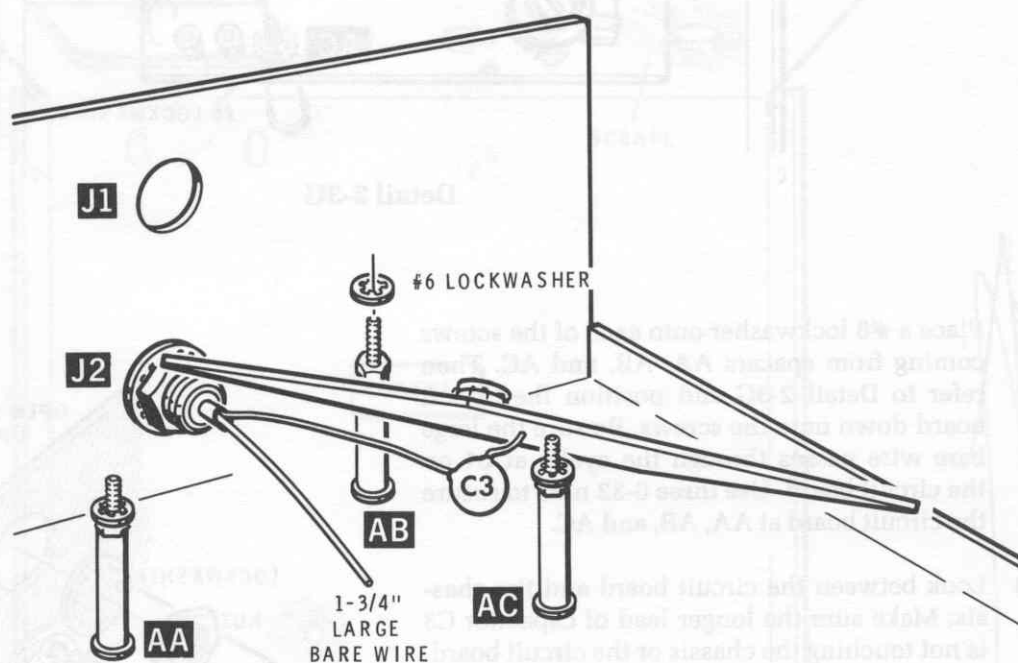

Detail 2-3F

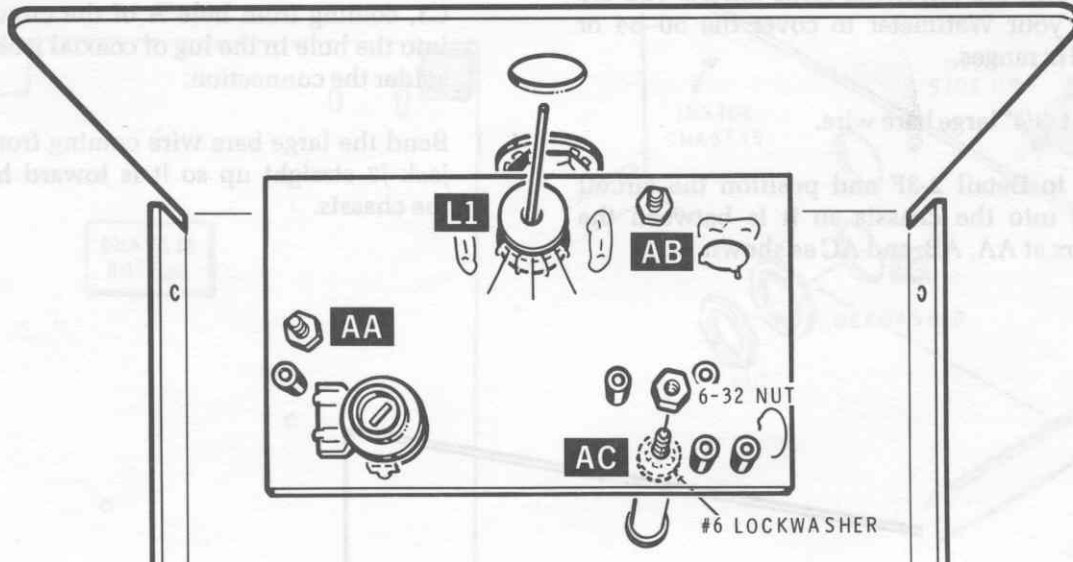

Detail 2-3G

Place a #6 lockwasher onto each of the screws coming from spacers AA, AB, and AC. Then refer to Detail 2-3G and position the circuit board down onto the screws. Be sure the large bare wire passes through the eyelet at L1 on the circuit board. Use three 6-32 nuts to secure the circuit board at AA, AB, and AC.

Look between the circuit board and the chassis. Make sure the longer lead of capacitor C3 is not touching the chassis or the circuit board. Reposition the capacitor as necessary.

J1: Refer to Detail 2-3H and mount a coaxial jack onto the rear of the chassis at J1. Use the hardware supplied with the jack. Be sure to position the jack so the open side of the lug is upward.

Cut a 3/4" length of sleeving. Then refer to Detail 2-3J and slide the sleeving onto the large bare wire coming from the eyelet at J1. Be sure the sleeving is centered in the eyelet (so the wire cannot touch the eyelet).

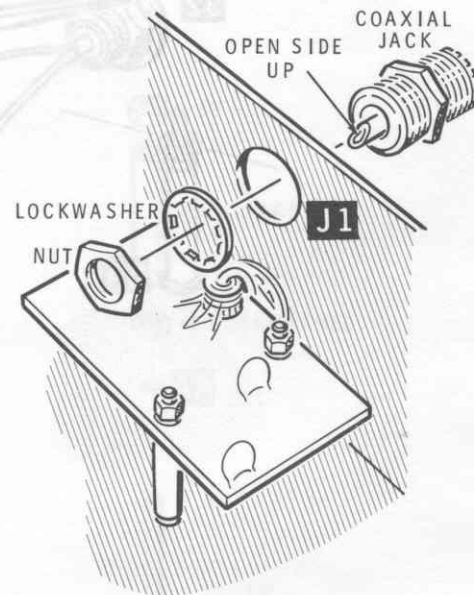

Detail 2-3H

Heathkit®

- () Refer again to Detail 2-3J and position the free end of the large bare wire, coming from the eyelet at L1, into the hole in the lug of coaxial jack J1. (Cut off any excess wire length.) Also position the free end of the lead coming from capacitor C1 in the hole in the lug of coaxial jack J1. Then solder the connection.

Proceed to "Common Assembly Continued."

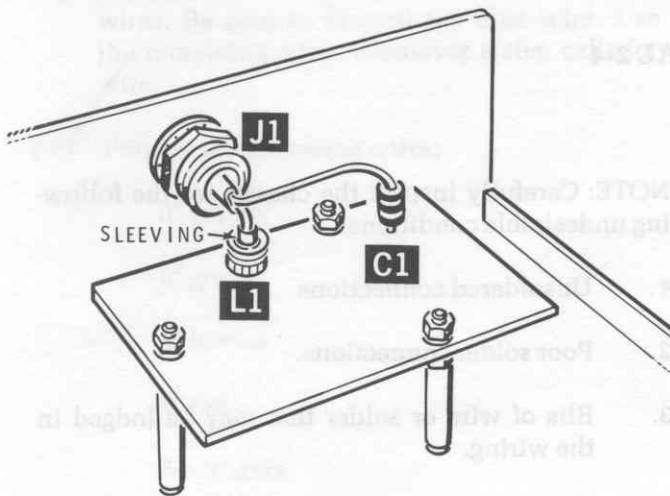

Detail 2-3J

Common Assembly Continued

Connect the free ends of the wires coming from the circuit board to the switches on the front of the chassis as follows:

- () Red wire to switch S2 lug 2 (S-2).
- () Brown wire to switch S2 lug 3 (S-2).
- () Remove an additional 1/4" of insulation (total 1/2") from the free end of the gray wire. Then connect the end of the wire to the control solder lug (S-5).
- () Yellow wire to switch S1 lug 4 (S-1).
- () Green wire to switch S1 lug 6 (S-1).
- () Dress the wires coming from the circuit board as neatly as possible. Then refer to the inset drawing on the Pictorial and install two cable ties around the wires in the areas shown.



Detail 2-4A

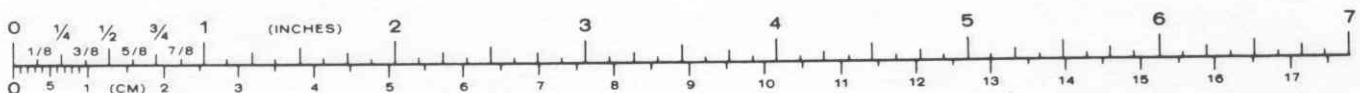

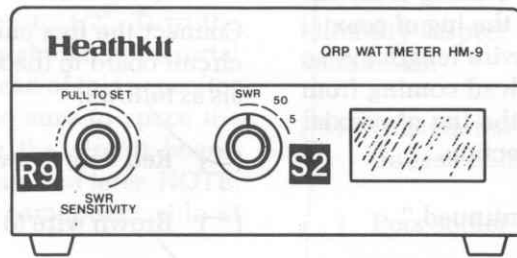

PICTORIAL 2-4

Refer to Pictorial 2-4 for the following steps.

- () Turn the shafts of control R9 and switch S2 fully counterclockwise.
- () Refer to Detail 2-4A and start a 6-32 × 1/8" setscrew into one of the knobs. Push the knob onto the shaft of control R9. Then turn the knob so the pointer is at the 7 o'clock position and tighten the setscrew.
- () Similarly, start a 6-32 × 3/16" setscrew into the remaining knob. Push the knob onto the shaft of switch S2. Then line up the knob pointer with the "SWR" label on the front panel and tighten the setscrew (against the flat on the shaft).

NOTE: Carefully inspect the chassis for the following undesirable conditions:

1. Unsoldered connections.
2. Poor solder connections.
3. Bits of wire or solder that may be lodged in the wiring.
4. Leads that could short to the chassis, to other wires, or to lugs to which they are not connected. Pay particular attention to the leads of the capacitors that are connected to the coaxial jacks.

NOTE: You will have several parts left over, depending upon the frequency range of the Wattmeter you are assembling.

Proceed to "Calibration."

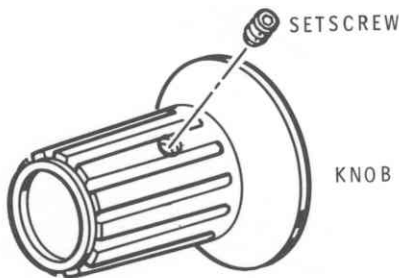

Detail 2-4A

CALIBRATION

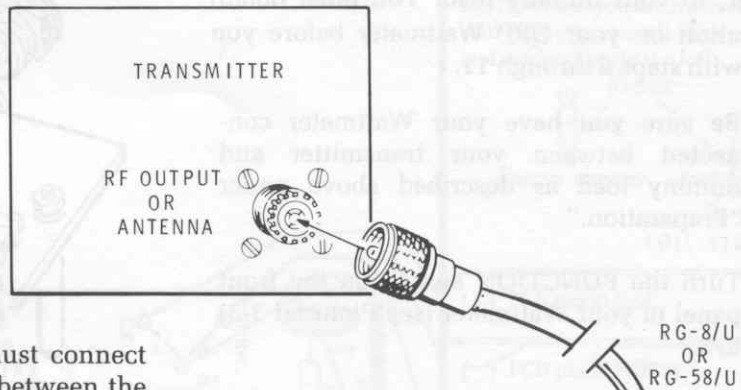

To perform the following steps, you must connect the Wattmeter in the transmission line between the transmitter and the load. You will use an internal calibration circuit to adjust the Wattmeter.

NOTE: If you have another accurate wattmeter (that covers the same frequency range as your QRP Wattmeter), you can use that wattmeter to calibrate your QRP Wattmeter with similar results. Simply connect the two wattmeters in series and adjust POWER CALIBRATE control R6 until the two meters agree.

PREPARATION

- () Refer to Pictorial 3-1 and connect a 50 Ω non-inductive load, such as the Heathkit Antenna, to the OUTPUT connector. Then connect the output of your transmitter to the INPUT connector. NOTE: The transmitter you use must be capable of delivering 1-1/2 to 5 watts.
- () Refer to Pictorial 3-2 and push the steel blade into the smaller end of the nut starter as shown. Leave about 1/4" of the blade exposed. NOTE: Use this tool to make the adjustments in the following steps.

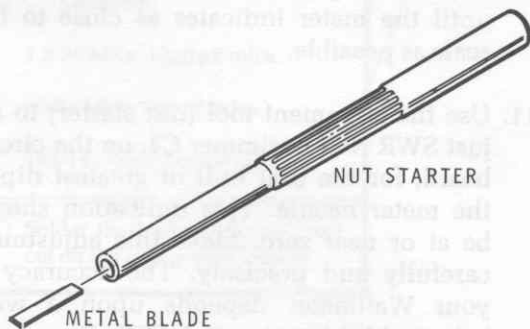

PICTORIAL 3-2

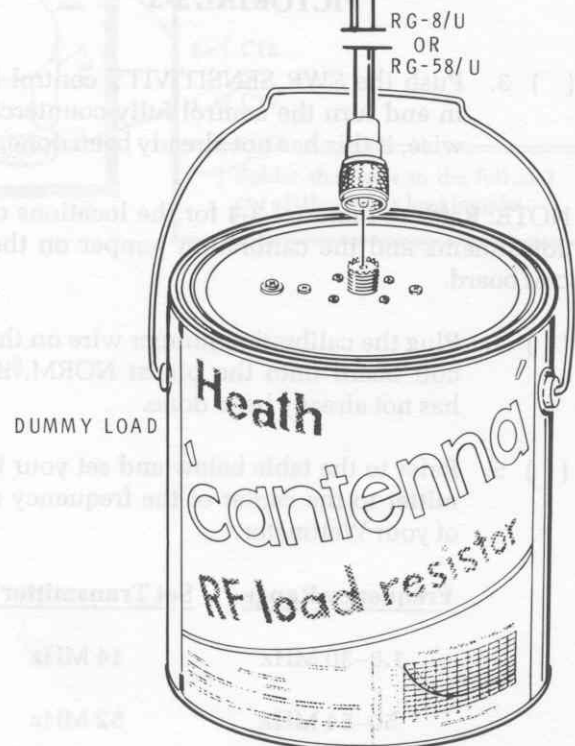

PICTORIAL 3-1

SWR BALANCE ADJUSTMENT

NOTE: Perform steps 1 through 7 to make sure you have a normal output from your transmitter, through the meter, to your dummy load. You **must** obtain an indication on your QRP Wattmeter before you proceed with steps 8 through 11.

- () 1. Be sure you have your Wattmeter connected between your transmitter and dummy load as described above under "Preparation."
- () 2. Turn the FUNCTION switch on the front panel of your Wattmeter (see Pictorial 3-3) to 5.

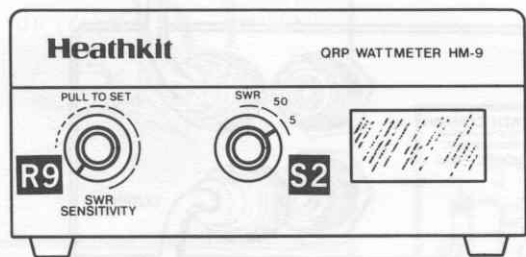

PICTORIAL 3-3

- () 3. Push the SWR SENSITIVITY control knob in and turn the control fully counterclockwise, if this has not already been done.

NOTE: Refer to Pictorial 3-4 for the locations of the adjustments and the calibration jumper on the circuit board.

- () 4. Plug the calibration jumper wire on the circuit board onto the pin at NORM, if this has not already been done.
- () 5. Refer to the table below and set your transmitter to the center of the frequency range of your Wattmeter.

Frequency Range	Set Transmitter To
1.8–30 MHz	14 MHz
50–54 MHz	52 MHz
144–148 MHz	146 MHz

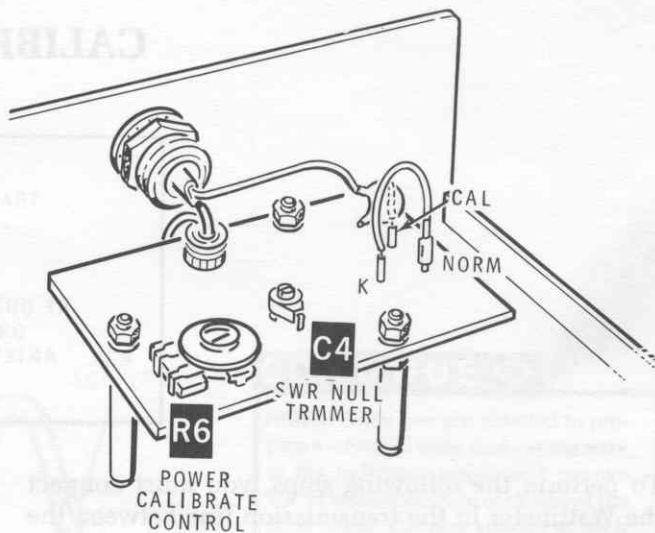

PICTORIAL 3-4

- () 6. Turn on your transmitter and set it to the CW mode. Set the transmitter so it puts out 1-1/2 to 5 watts (the closer to 5 watts, the better), if this has not already been done. Then key the transmitter and watch the Wattmeter needle move up-scale. If the meter does not move up-scale, turn off the transmitter and refer to the "In Case of Difficulty" section of this Manual.
- () 7. Release the transmitter key.
- () 8. Set the FUNCTION switch on your Wattmeter to SWR.
- () 9. Again key the transmitter.
- () 10. Be sure the SWR SENSITIVITY control knob is still pushed in. Then turn the knob until the meter indicates as close to full scale as possible.
- () 11. Use the alignment tool (nut starter) to adjust SWR NULL trimmer C4, on the circuit board, for the best null or greatest dip of the meter needle. This indication should be at or near zero. Make this adjustment carefully and precisely. The accuracy of your Wattmeter depends upon a well-balanced bridge circuit. NOTE: Do not use any metal tool other than the nut starter blade to make these adjustments.

Heathkit®

POWER METER

This section of the Manual contains two calibration procedures: one for calibrating the Wattmeter to the center of its frequency range, and one for calibrating it to some other frequency.

For maximum accuracy, you should calibrate the Wattmeter to the center of its frequency range, even if it is going to be used more often on a different frequency. Therefore, if your transmitter will tune to the center of the Wattmeter's frequency range (see step 5 above), use the "Normal Calibration" procedure to calibrate your meter. If your transmitter will not tune to this frequency, however, use the "Calibration on Other Frequencies" procedure. Since the meter readings are more accurate in the upper-half of the meter scale, it is desirable to use a transmitter that is capable of delivering 1-1/2 to 5 watts of output power for either calibration procedure.

Normal Calibration

- () Turn the FUNCTION switch on the front of the Wattmeter to 5, if this has not already been done.
- () Set the transmitter so it puts out 1-1/2 to 5 watts (the closer to 5 watts, the better), if this has not already been done.
- () Key the transmitter.
- () Complete the calibration procedure as follows:
 1. Unplug the calibration jumper on the circuit board from the NORM pin and plug it onto the CAL pin. Note the meter indication.
 2. Move the calibration jumper back to the NORM pin.
 3. Use the alignment tool to adjust POWER CALIBRATE control R6 until the meter indicates the same as it did in step 1 above.

4. Repeat steps 1 through 3 until the meter indicates the same with the calibration jumper in both positions.
- () Reconnect the calibration jumper to the NORM pin, if this has not already been done. This is the normal connection.

This completes the calibration of your Wattmeter. Proceed to "Final Assembly."

Calibration on Other Frequencies

NOTE: During the following steps, you will need a VTVM that has a high input impedance and an RF probe (or an RF voltmeter) to measure the RF output of your transmitting system.

If you cannot tune your transmitter to the center of your Wattmeter's frequency range, you can obtain acceptable calibration accuracy on another frequency by using the following formula:

$$P = \frac{E^2}{R}$$

Where P = watts output
E = RF voltage across the load
R = load resistance

To determine E, use an RF voltmeter or a VTVM/RF probe combination to measure the RF voltage across the 50-ohm resistive load (Cantenna).

With this method, the watts output as determined by the above formula is compared with the watts indication on the scale of the Wattmeter's meter. Then you adjust POWER CALIBRATE control R6 on the circuit board so it reads the same as the power determined by the formula.

EXAMPLE: If you wish to use the 25-watt figure on the meter scale for calibration and you are using a 50-ohm resistive load, set your transmitter output so the RF voltmeter across the load indicates 35.4-volts RF.

$$25 \text{ watts (P)} \times 50 \text{ ohms (R)} = 1250 \text{ (E}^2\text{)}$$

$$E = \sqrt{1250} = 35.4 \text{ volts}$$

When the RF voltmeter indicates 35 volts, you know the transmitter is putting out 25 watts. Therefore, you can adjust the Wattmeter to indicate 25 watts.

You can substitute any other figure between 10 and 50 into the formula and in the example.

If you have an accurate RF wattmeter, adjust POWER CALIBRATE control R6 on the circuit board so the wattmeters indicate the same.

- () 1. Select the power you wish to obtain from your transmitter.

- () 2. Use the power formula to calculate the RF voltage that should appear across the resistive load when the transmitter is putting out the selected power (refer to the example).
- () 3. Turn the FUNCTION switch on the front panel to 5 or 50, depending upon the output power of your transmitting system.
- () 4. Connect an RF voltmeter across the resistive load. NOTE: Do not exceed the current rating of your RF probe.
- () 5. Adjust the transmitter output so the RF voltage across the resistive load is the same as the calibrated RF voltage.
- () 6. Adjust POWER CALIBRATE control R6, on the circuit board, until the QRP Wattmeter indicates the power you selected to obtain from the transmitter.

This completes the calibration of your Wattmeter. Proceed to "Final Assembly."

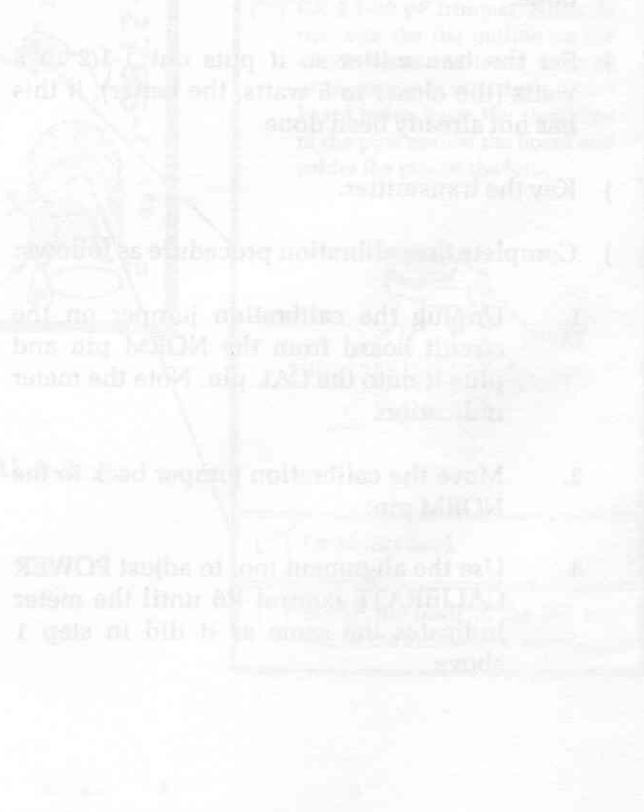
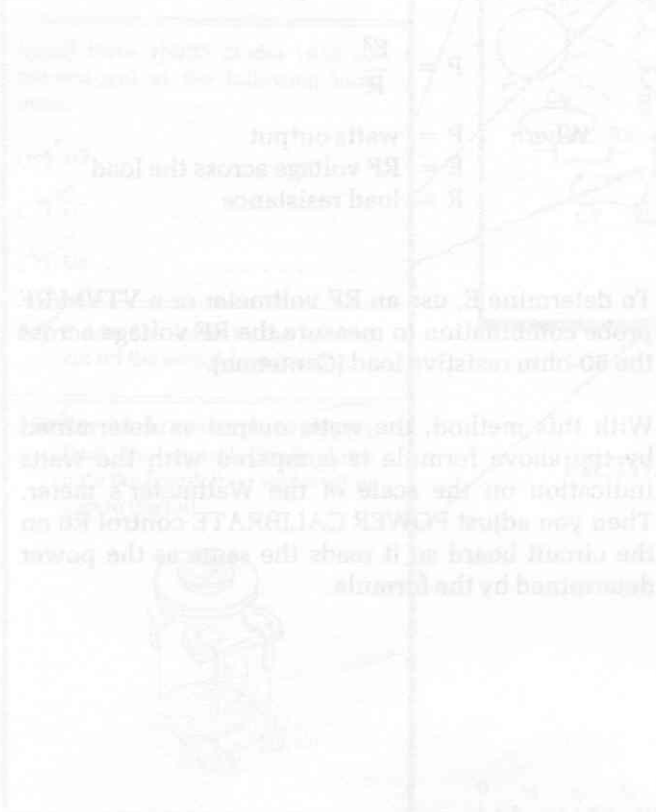

STEP-BY-STEP ASSEMBLY

FINAL ASSEMBLY

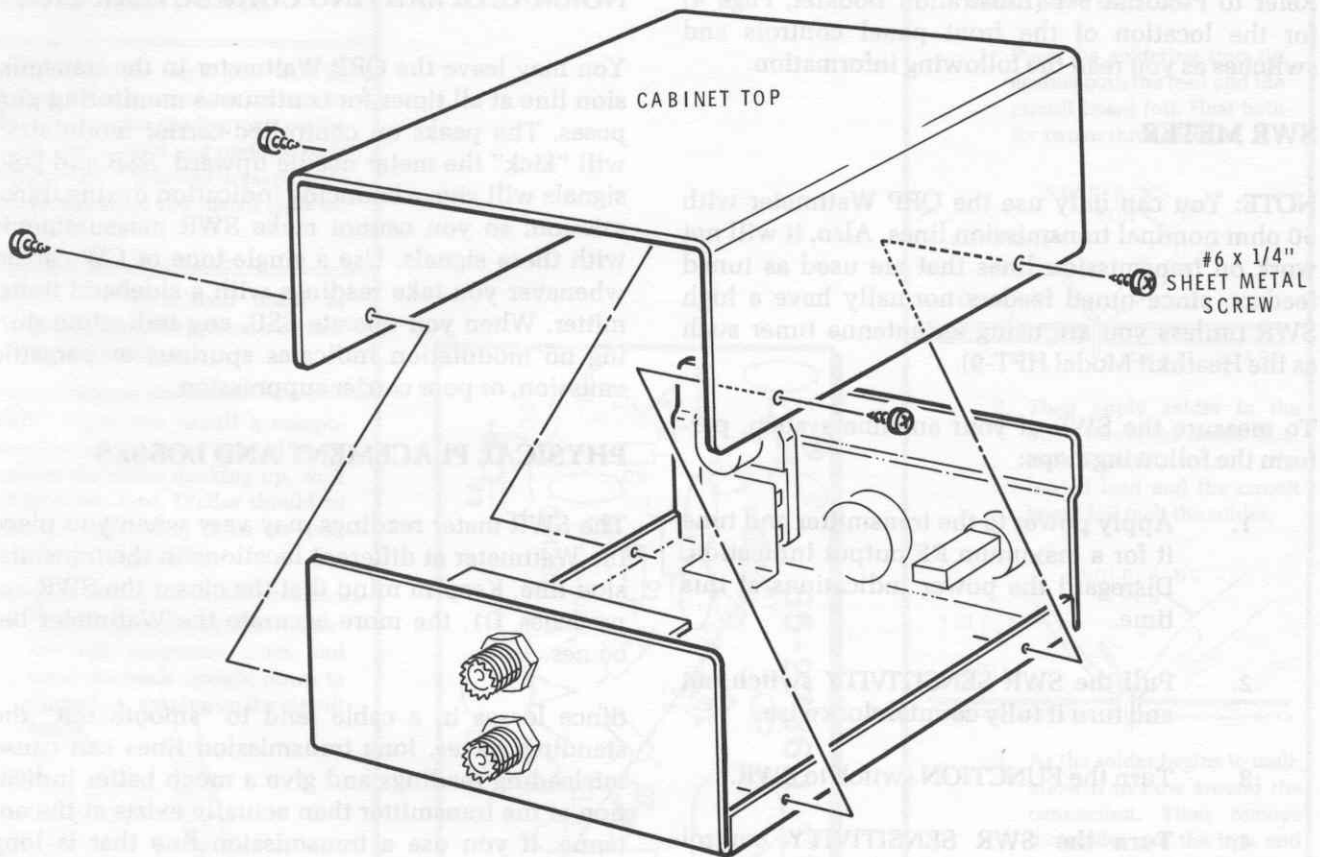

PICTORIAL 4-1

Refer to Pictorial 4-1 for the following steps.

- () Slide the cabinet top onto the chassis. Then secure the cabinet top to the chassis with four #6 × 1/4" sheet metal screws.
- () Turn the chassis so it is bottom-side-up. Then carefully peel the backing paper from the blue and white label and press the label onto the

bottom of the chassis. Be sure to refer to the numbers on this label in any communications you may have with the Heath Company about your kit.

This completes the assembly of your Wattmeter. Proceed to "Operation."

OPERATION

Refer to Pictorial 5-1 (Illustration Booklet, Page 4) for the location of the front panel controls and switches as you read the following information.

SWR METER

NOTE: You can only use the QRP Wattmeter with 50 ohm nominal transmission lines. Also, it will not work on transmission lines that are used as tuned feeders, since tuned feeders normally have a high SWR (unless you are using an antenna tuner such as the Heathkit Model HFT-9).

To measure the SWR of your antenna system, perform the following steps:

1. Apply power to the transmitter and tune it for a maximum RF output indication. Disregard the power indications at this time.
2. Pull the SWR SENSITIVITY switch out and turn it fully counterclockwise.
3. Turn the FUNCTION switch to SWR.
4. Turn the SWR SENSITIVITY control clockwise for a midscale meter indication. A minor "touch-up" tuning of the transmitter may show an increase on the meter.
5. Turn the SWR SENSITIVITY control clockwise until the meter indicates full scale.
6. Push the SWR SENSITIVITY control knob **in** and read the standing-wave-ratio directly on the upper meter scale.

NORMAL OPERATING CHARACTERISTICS

You may leave the QRP Wattmeter in the transmission line at all times for continuous monitoring purposes. The peaks on controlled-carrier modulation will "kick" the meter needle upward. SSB and DSB signals will give a bouncing indication during transmission; so you cannot make SWR measurements with these signals. Use a single-tone or CW carrier whenever you take readings with a sideband transmitter. When you operate SSB, any indication during no modulation indicates spurious or parasitic emission, or poor carrier suppression.

PHYSICAL PLACEMENT AND LOSSES

The SWR meter readings may vary when you place the Wattmeter at different locations in the transmission line. Keep in mind that the closer the SWR approaches 1:1, the more accurate the Wattmeter becomes.

Since losses in a cable tend to "smooth out" the standing waves, long transmission lines can cause misleading readings and give a much better indication at the transmitter than actually exists at the antenna. If you use a transmission line that is long enough to have appreciable losses, try to locate the Wattmeter near the antenna, especially when you are adjusting beams or tuning traps. You can better understand the extent of this effect when you realize that a line with a 3 dB loss will show an SWR of 3 when it is terminated in a dead short. A line with a loss of over 10 dB will show an SWR of practically 1:1 on this or any other SWR meter, regardless of what load or termination is present at the far end.

Heathkit®

The power losses in these cases occur in the cable, but the SWR meter reading will not indicate that anything is wrong. When you are in doubt, make measurements at the antenna and at the transmitter, so future changes in the readings will be meaningful. Pictorial 5-2 (Illustration Booklet, Page 4) shows the values of cable losses at various frequencies. These losses become worse as time and moisture affect the cable.

With a high SWR, the transmission line losses may become so great that the radiated power is appreciably reduced; with high-power transmitters, the cable ratings may be exceeded. Pictorial 5-3 (Illustration Booklet, Page 4) shows the effect of increasing cable losses caused by various values of SWR. When these losses occur, the RF power is turned into heat in the cable instead of being radiated from the antenna.

To obtain total losses in a given length of coaxial cable, determine the dB loss per foot of the cable from Pictorial 5-2. To do this, first find your operating frequency on the bottom line of the chart. Then move up the chart until you find the type of cable you are using. The line at the left side of the chart shows the dB loss per 100 feet of the cable at your frequency.

Now use Pictorial 5-3 to determine the additional loss caused by the SWR as follows: Use the amount of loss determined from Pictorial 5-2 and find this value on the bottom line of the chart in Pictorial 5-3. Now move up the graph until you come to the SWR of your antenna system. The left side of the chart shows the amount of loss caused by the SWR. To obtain the total loss of your system, add the value from Pictorial 5-2 to the value from Pictorial 5-3. Now multiply the total loss by the cable length in feet and divide the result by 100.

LOADING

The load presented to the transmitter output circuit may create conditions that make it touchy or impossible to load the transmitter. With a low SWR, the load that the transmitter sees is practically pure resistive. At a high SWR, however, the apparent load may change from a very low to a very high resistance, accompanied by either capacitive or inductive reactance. These resistance and reactive values change when the transmission line length or frequency changes.

Remember when you use 50 ohm nominal unbalanced feed lines that you cannot change the SWR by changing the transmission line length. You can change the loading to the transmitter considerably, however, thus making it appear that "pruning" the cable length offers improvement; it actually does not affect the SWR.

You can only change the SWR by changing the load or termination at the end of the cable. If you change the transmission line length, for example, with 50 ohm cable and an SWR of 3, the apparent load to the transmitter may vary from 16-2/3 ohm to 150 ohm resistive in series with reactance varying from 66-2/3 ohm capacitive, to zero, and to 66-2/3 ohm inductive. If the transmitter output tuning adjustments will not accommodate this impedance range, the transmitter will be difficult to load until the load is matched and the SWR is low, approaching 1:1.

POWER METER

The operation of the wattmeter is relatively uncomplicated. Simply turn the FUNCTION switch to either the 5 or the 50-watt position. Then read the corresponding scale on the meter to obtain the power output of the transmitter. NOTE: A 50 Ω non-reactive load (for accurate measurements) must be connected to the OUTPUT jack of the Wattmeter.

1	1	1	1
5	5	5	5
10	10	10	10
15	15	15	15
20	20	20	20
25	25	25	25
30	30	30	30
35	35	35	35
40	40	40	40
45	45	45	45
50	50	50	50
55	55	55	55
60	60	60	60
65	65	65	65
70	70	70	70
75	75	75	75
80	80	80	80
85	85	85	85
90	90	90	90
95	95	95	95
100	100	100	100

IN CASE OF DIFFICULTY

NOTE: Refer to the "Circuit Board X-Ray View" (Page 41) for the physical location of parts on the circuit board.

1. Recheck the wiring. Trace each lead with a colored pencil on the Pictorial as you check it. It is frequently helpful to have a friend check your work. Someone who is not familiar with the unit may notice something that you have consistently overlooked.
2. About 90% of the kits that are returned to the Heath Company for service do not function properly due to poor connections and soldering. Therefore, you can eliminate many troubles by reheating all of the connections to make sure they are well soldered.
3. Check the values of the parts. Be sure the proper part has been installed at each location on the circuit board. It would be easy, for ex-

ample, to install a 4700 Ω (yel-viol-red) resistor where a 47 k Ω (yel-viol-org) resistor should have been installed.

4. Be sure all of the wires and leads have been trimmed as close as possible to their connection points.
5. Check for bits of solder, wire ends, or other foreign matter that may be lodged in the wiring.
6. A review of the "Circuit Description" and the Schematic Diagram may also help you locate a trouble.

NOTE: In an extreme case where you are unable to resolve a difficulty, refer to the "Customer Service" information inside the rear cover of this Manual. Your Warranty is located inside the front cover.

Troubleshooting Chart

The following chart lists the condition and the possible causes of several malfunctions. If a particular part is mentioned as a possible cause, check that part to see if it was correctly installed. Also check

the parts connected to it for poor connections. It is also possible, on rare occasions, for a part to be faulty and require replacement.

PROBLEM	POSSIBLE CAUSE
Meter reads down-scale on SWR or wattmeter.	<ol style="list-style-type: none"> 1. Meter wired wrong. 2. Diode D1 or D2 installed wrong.
Higher meter reading for SWR than for SWR Set.	<ol style="list-style-type: none"> 1. Input and output cables connected wrong. 2. Pickup coil L1 wired wrong. 3. Switch S2 wired wrong.
Calibrator portion of meter does not function correctly.	<ol style="list-style-type: none"> 1. Input and output cables connected wrong. 2. Diode D3 installed wrong. 3. Capacitor C1, C2, C9, C13, or C15. 4. Resistor R1.
SWR reads while the transmitter is off.	<ol style="list-style-type: none"> 1. Nearby transmitter in operation.
Inaccurate readings after calibration.	<ol style="list-style-type: none"> 1. Leads of capacitors C1 and C2 are too long.

SPECIFICATIONS

Frequency Range	1.8 to 30 MHz, 50 to 54 MHz, or 144 to 148 MHz, builder option.
Wattmeter Accuracy	± 10% of full-scale reading.*
Power Capability	To 50 watts.
Power Ranges	0 to 5 watts, 0 to 50 watts.
SWR Sensitivity	Less than 1.5 watts.
Impedance	50 ohms nominal.
SWR Bridge	Continuous to 50 watts.
Connectors	UHF type SO-239.
Dimensions	5-3/8" wide × 2-5/8" high × 7" deep. (13.6 × 7.3 × 17.8 cm)
Weight	1.1 lbs. (.5 kg).

Heath Company reserves the right to discontinue products and to change specifications at any time without incurring any obligation to incorporate new features in products previously sold.

This set of
 specifications
 is a high of
 Heathkit's
 quality. Multiply this
 value by 1.15
 to get the actual
 value.

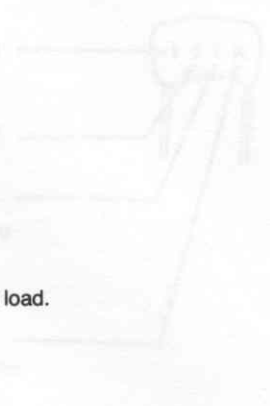

* Using a 50 ohm resistive load.

MULTIPLIER	FOR THE SQUARE	MEASUREMENT	TOLERANCE OF CAPACITOR		
			10 pF OR LESS	LETTER	OVER 10 pF
1	1	100	± 10%	B	± 10%
1	1	100	± 20%	C	± 20%
1	1	100	± 30%	D	± 30%
1	1	100	± 40%	F	± 40%
1	1	100	± 50%	G	± 50%
1	1	100	± 60%	H	± 60%
1	1	100	± 70%	J	± 70%
1	1	100	± 80%	K	± 80%
1	1	100	± 90%	M	± 90%

CIRCUIT BOARD X-RAY VIEW

NOTE: To find the PART NUMBER of a component for the purpose of ordering a replacement part:

A. Find the circuit component number (C1, R3, etc.) on the X-Ray View.

B. Locate this same number in the "Circuit Component Number" column of the "Parts List" (beginning on Page 6).

C. Adjacent to the circuit component number, you will find the PART NUMBER and DESCRIPTION, which must be supplied when you order a replacement part.

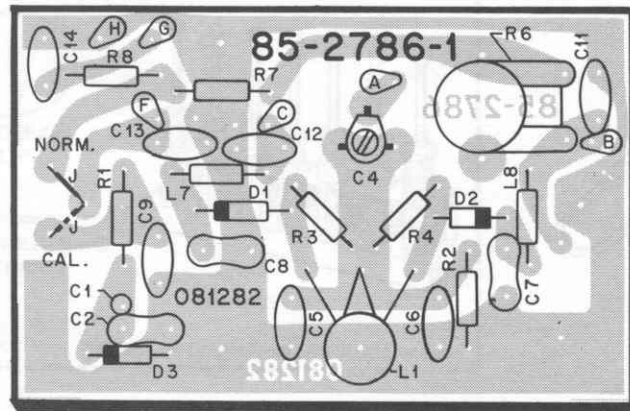

(Shown from the component side.)



HEATH COMPANY
BENTON HARBOR, MICHIGAN 49022

IMPORTANT NOTICE

Please make the following changes in your Manual before you begin to assemble the kit.

Page 6 — Right column, under “Resistors (Cont’d).” Change the fourth item listed (6-4991-12) to read:

6-5231-12 1 5230 Ω , 1% (grn-red-org-brn) R1

— Change the sixth item listed (6-6341-12) to read:

6-6651-12 1 6650, 1% (blu-blu-grn-brn) R1

— Change the seventh item listed (6-2872-12) to read:

6-2742-12 1 27.4 k Ω , 1% (red-viol-yel-red) R8

NOTE: The above three parts are attached to this Notice. You will have some resistors left over when you finish building your kit.

Page 11 — Left column. Change the third step to read:

() R1: Resistor.

1.8-30 MHz: 6650 Ω , 1% (blu-blu-grn-brn).

50-54 MHz: 5230 Ω , 1% (grn-red-org-brn).

144-148 MHz 5490 Ω , 1% (grn-yel-wht-brn).

— Right column. Change the first step to read:

() R8: Resistor.

1.8-30 MHz: 45.3 k Ω , 1% (yel-grn-org-red).

50-54 MHz: 27.4 k Ω , 1% (red-viol-yel-red).

144-148 MHz: 30.9 k Ω , 1% (org-blk-wht-red).

Page 21 — Pictorial 2-2. Locate the unlabeled wire that is connected to switch S2 lug 1. Then label this wire “4” RED”.

HM-9/595-2979
591-4354

CUSTOMER SERVICE

REPLACEMENT PARTS

Please provide complete information when you request replacements from either the factory or Heath Electronic Centers. Be certain to include the **HEATH** part number exactly as it appears in the parts list.

ORDERING FROM THE FACTORY

Print all of the information requested on the parts order form furnished with this product and mail it to Heath. For telephone orders (parts only) dial 616 982-3571. If you are unable to locate an order form, write us a letter or card including:

- Heath part number.
- Model number.
- Date of purchase.
- Location purchased or invoice number.
- Nature of the defect.
- Your payment or authorization for COD shipment of parts not covered by warranty.

Mail letters to: Heath Company
Benton Harbor
MI 49022
Attn: Parts Replacement

Retain original parts until you receive replacements. Parts that should be returned to the factory will be listed on your packing slip.

OBTAINING REPLACEMENTS FROM HEATH ELECTRONIC CENTERS

For your convenience, "over the counter" replacement parts are available from the Heath Electronic Centers listed in your catalog. Be sure to bring in the original part and purchase invoice when you request a warranty replacement from a Heath Electronic Center.

TECHNICAL CONSULTATION

Need help with your kit? — Self-Service? — Construction? — Operation? — Call or write for assistance. you'll find our Technical Consultants eager to help with just about any technical problem except "customizing" for unique applications.

The effectiveness of our consultation service depends on the information you furnish. Be sure to tell us:

- The Model number and Series number from the blue and white label.
- The date of purchase.
- An exact description of the difficulty.
- Everything you have done in attempting to correct the problem.

Also include switch positions, connections to other units, operating procedures, voltage readings, and any other information you think might be helpful.

Please do not send parts for testing, unless this is specifically requested by our Consultants.

Hints: Telephone traffic is lightest at midweek — please be sure your Manual and notes are on hand when you call.

Heathkit Electronic Center facilities are also available for telephone or "walk-in" personal assistance.

REPAIR SERVICE

Service facilities are available, if they are needed, to repair your completed kit. (Kits that have been modified, soldered with paste flux or acid core solder, cannot be accepted for repair.)

If it is convenient, personally deliver your kit to a Heathkit Electronic Center. For warranty parts replacement, supply a copy of the invoice or sales slip.

If you prefer to ship your kit to the factory, attach a letter containing the following information directly to the unit:

- Your name and address.
- Date of purchase and invoice number.
- Copies of all correspondence relevant to the service of the kit.
- A brief description of the difficulty.
- Authorization to return your kit COD for the service and shipping charges. (This will reduce the possibility of delay.)

Check the equipment to see that all screws and parts are secured. (Do not include any wooden cabinets or color television picture tubes, as these are easily damaged in shipment. Do not include the kit Manual.) Place the equipment in a strong carton with at least **THREE INCHES** of *resilient* packing material (shredded paper, excelsior, etc.) on all sides. Use additional packing material where there are protrusions (control sticks, large knobs, etc.). If the unit weighs over 15 lbs., place this carton in another one with 3/4" of packing material between the two.

Seal the carton with reinforced gummed tape, tie it with a strong cord, and mark it "Fragile" on at least two sides. Remember, the carrier will not accept liability for shipping damage if the unit is insufficiently packed. Ship by prepaid express, United Parcel Service, or insured Parcel Post to:

Heath Company
Service Department
Benton Harbor, Michigan 49022



HEATH COMPANY • BENTON HARBOR, MICHIGAN
THE WORLD'S FINEST ELECTRONIC EQUIPMENT IN KIT FORM

LITHO IN U.S.A.