



## 2nd Charger Upgrade, 1st Generation

<b>Classification</b>	Parts and Accessories Bulletin	<b>Section/Group</b>	44 - High Voltage System	<b>Country/Region</b>	North America
<b>Year</b>	2012-2013	<b>Model</b>	Model S	<b>Version</b>	All

**Bulletin Classification:** This bulletin provides instructions and guidelines for a vehicle procedure that is not the result of a defect. This bulletin might not be VIN-specific. These instructions assume knowledge of motor vehicle and high voltage electricity repairs, and should only be executed by trained professionals. Tesla Motors assumes no liability for injury or property damage due to a failure to properly follow these instructions or repairs attempted by unqualified individuals.

This Service Bulletin supersedes SB-12-44-005 R4, dated 28-Aug-14. Each content change is marked by a vertical line in the left margin. Discard the previous version and replace it with this one.

This bulletin describes how to install a second (slave) charger in a vehicle that is currently only configured for one charger. This requires reconfiguring the coolant lines and firmware.

**NOTE:** This bulletin is valid for North American vehicles built before October 16, 2013 and from November 1, 2013–December 2, 2013. Refer to SB-13-44-010 for other vehicles.

Required Part(s):	Part Number	Description	Quantity
	6009278-00-F	ASY,CHRGR,10kW	1
	1008531-00-C	ASY,GRND STRAP,BRAIDED,WITH TERM,CHRGR	1
	1008770-00-A	BOLT,M6-1.0X12,FHCS,DIN6921,G10.9,ZF720	1
	1006799-00-B	NUT,HEX,M6,1.0,STL,ZNCFL1000,SL	4
	1019470-00-A	HOSE RING, CLIPPABLE, 25MM ID X 30MM L	1
	1012820-00-A	COOLANT, ETHYLENE GLYCOL, 50/50 MIX - 1 GALLON	1
	1025558-00-A*	SECOND CHARGER KIT*	1*

\*This part number is for customer billing only. Order components separately, as listed above.

These part numbers were current at the time of publication. Use the revisions listed or later, unless otherwise specified in the Parts Manual.

Correction Description	Correction	Time
Inspection Only; Charger Installation Not Required	S011244005	0.1
Install 1st Generation Slave Charger	S021244005	2.1

## Configure the New Slave Charger

**⚠ WARNING:** Only technicians who have been trained in High Voltage Awareness are permitted to perform this procedure. Proper personal protective equipment (PPE) and insulating HV gloves with a minimum rating of class 00 (500V) must be worn any time a high voltage cable is handled. Refer to service bulletin SB-13-92-003, "High Voltage Awareness Care Points", for additional safety information.

1. Disconnect HV power, but leave 12V power connected. Perform the electrical isolation procedure (refer to Service Manual procedure 17010000), except for the disconnection of the 12V battery ground.
2. Connect an external charger to the 12V battery.

**NOTE:** It is necessary to support the 12V battery with the external charger while configuring the slave charger.

3. Remove the 2<sup>nd</sup> row seat frame (refer to Service Manual procedure 13023002).

**TIP:** It is possible to remove the 8 bolts that secure the 2<sup>nd</sup> row seat frame (Figure 1) and temporarily secure the frame to the 2<sup>nd</sup> row seat backrest for access.

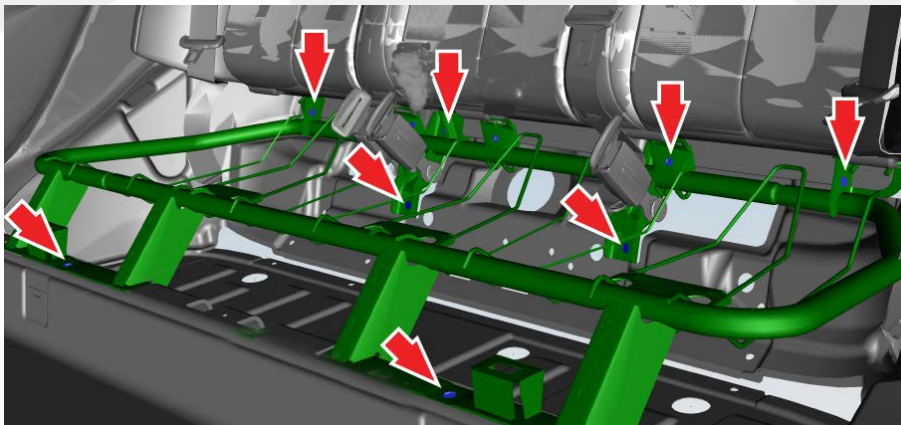
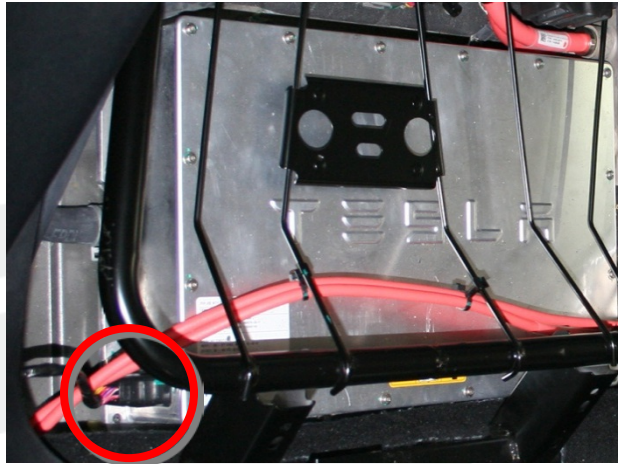

Figure 1

4. Confirm that the vehicle has a 1<sup>st</sup> generation charger (Figure 2). If the vehicle has a 2<sup>nd</sup> generation charger, do not perform this procedure; refer to SB-13-44-010 instead.
5. Disconnect the master charger low voltage connector from the outboard side of the charger (Figure 2).



**Figure 2 (Shown with seat frame installed)**

6. Temporarily place the new slave charger on top of the master charger.
7. Connect the low voltage connector to the new slave charger.
8. Connect a laptop with Toolbox to the diagnostic port and powertrain CAN bus.
9. In Toolbox, select Views > HV Electronics > Charger Config.
10. Click the switch button (Figure 3).

**NOTE:** Do not click the Update Vehicle Charger Config button yet.

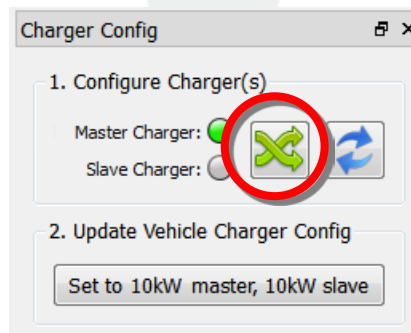

**Figure 3**

11. Disconnect the low voltage connector from the new slave charger.
12. Temporarily remove the slave charger.
13. Connect the low voltage connector to the master charger.

**NOTE:** Leave the laptop connected to the vehicle.

## Install the New Slave Charger

1. Disconnect the 12V external charger.
2. Disconnect 12V power (refer to Service Manual procedure 17010100).
3. Remove the HVJB cover (refer to Service Manual procedure 44300202).

**⚠ WARNING:** Measure for voltage across the HVJB terminals. If voltage is present across the terminals, contact Service Engineering. Due to the risk of electrocution, do not continue with this procedure until a zero voltage reading is verified.

4. Disconnect the 5 connectors that attach the HVJB to the master charger (Figure 4).

**NOTE:** Note the positions of all components before removal.

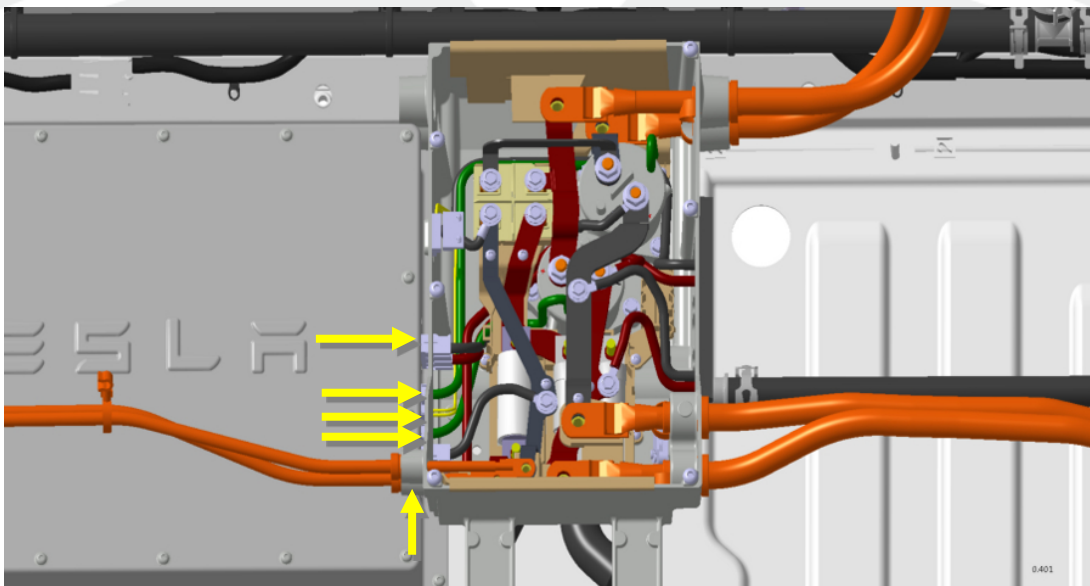
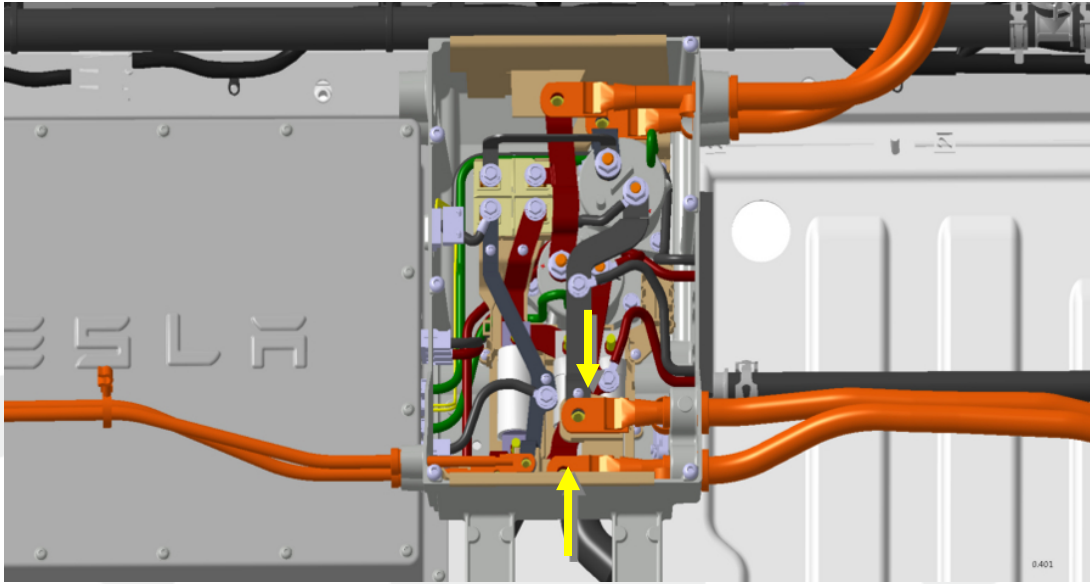

Figure 4

5. Remove the 2 bolts that secure the positive and negative charge port cables inside the HVJB (torque 9 Nm).

6. Release the 2 quick connectors that secure the charge port cables to the HVJB body (Figure 5). Move the cables aside.



**Figure 5**

7. Release the 2 clips that secure the charger coolant hose to the body.
8. Move the coolant hose aside for access to the HVJB bracket bolts (Figure 6).

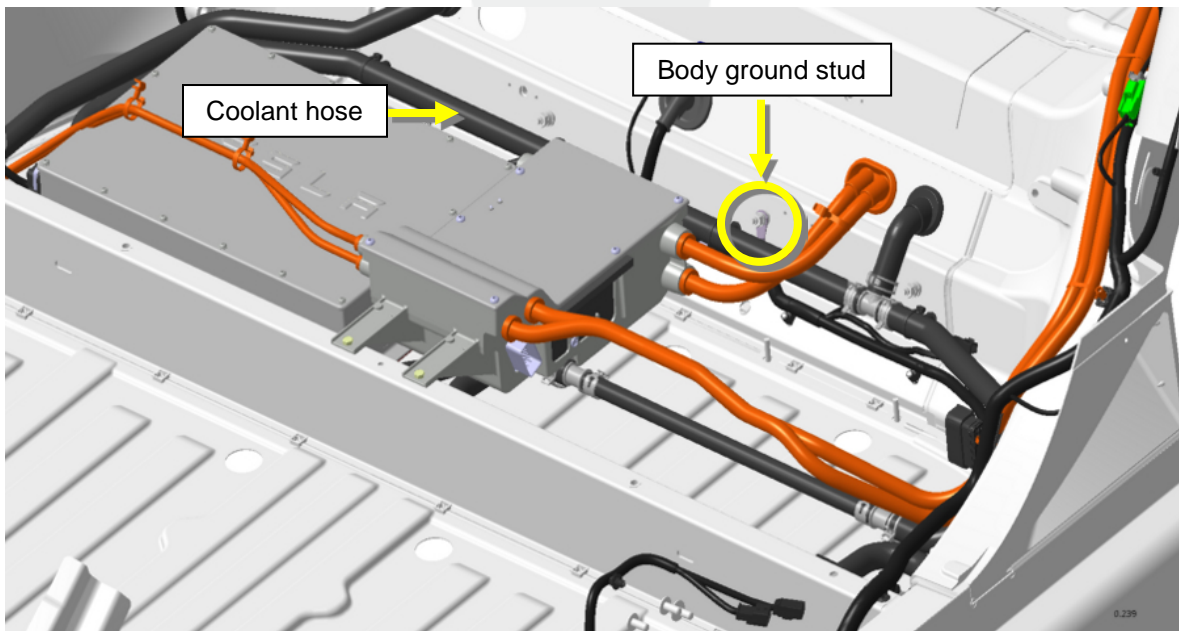

**Figure 6**

9. Remove the HVJB ground strap from the body ground stud (torque 9 Nm) (Figure 6).

10. Remove the 4 bolts that secure the HVJB (torque 5 Nm) (Figure 7).

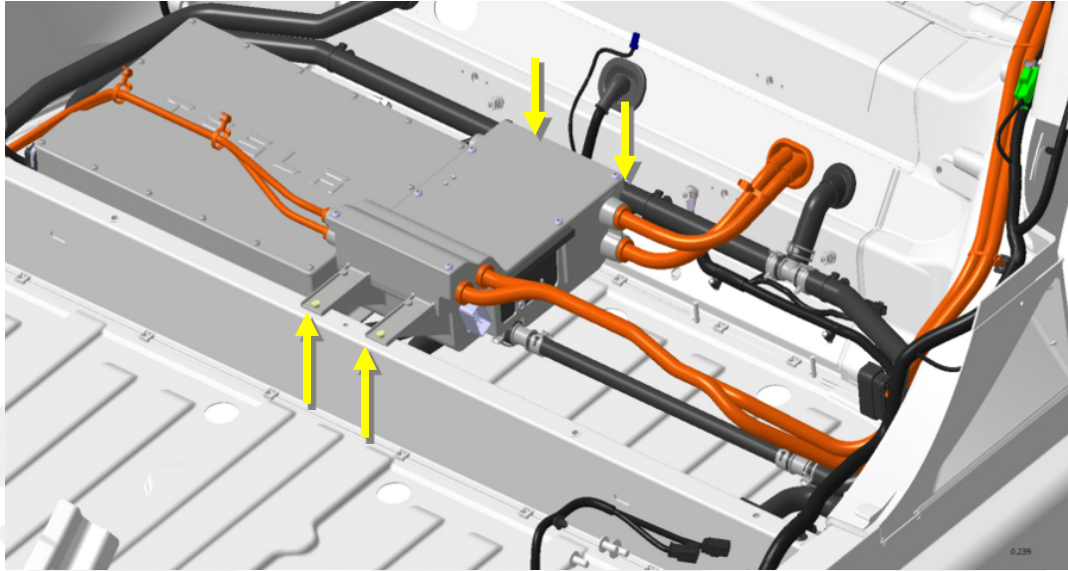
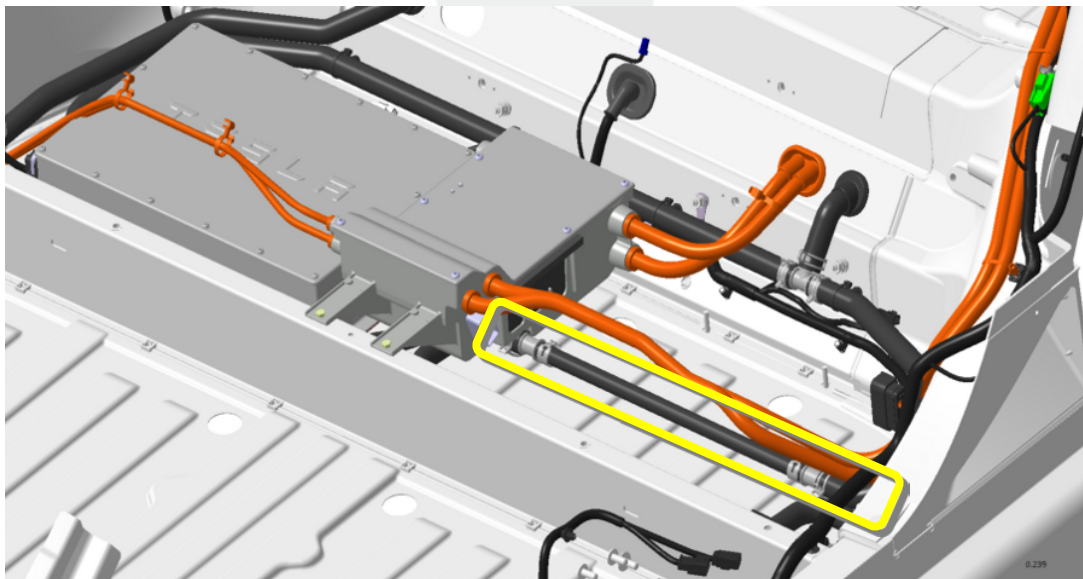

**Figure 7**

11. Move the HVJB aside for access.

12. Disconnect the harness connector from the side of the HVJB.

13. Locate the restrictors on each end of the substitute coolant hose running across the empty charger bay (Figure 8). Clamp both hoses on the outside of each restrictor to minimize coolant loss.



**Figure 8 (Substitute coolant hose and restrictors)**

14. Place shop towels around the affected area to absorb any coolant spills.

15. Release the 2 hose clips.

16. Disconnect the substitute coolant hose. Remove the hose and both restrictors.

17. Before beginning installation, pull the three connectors for the slave charger out of the side of the HVJB (one HVIL loop, one input, one output) (Figure 9).

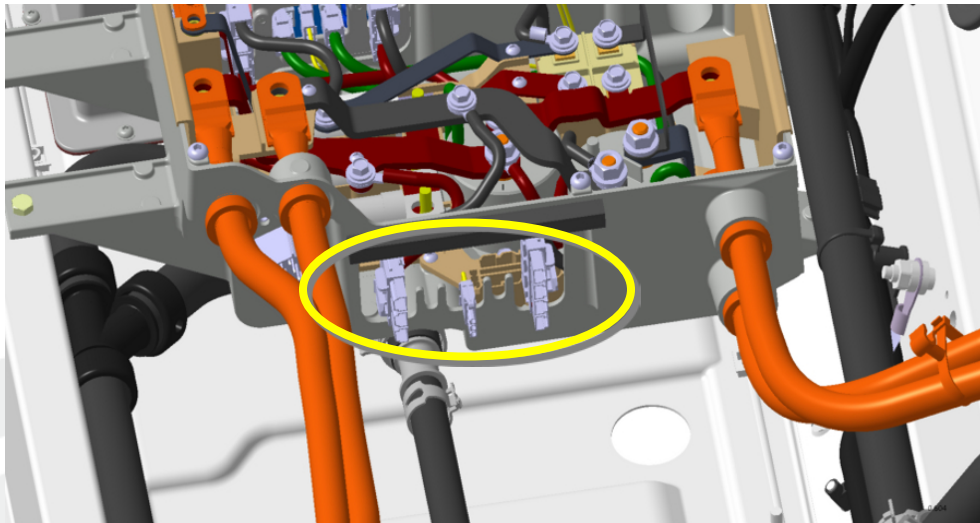

**Figure 9 (Slave connectors)**

18. Attach the ground strap to the slave charger (torque 5 Nm) prior to placing the charger in position.
19. Place the charger in position and attach the coolant hoses. Tighten the mounting nuts (torque 6.5 Nm).
20. Position the HVJB back in place. Reinstall the 4 bolts that secure the HVJB (torque 5 Nm).
21. Reinstall the ground strap for the HVJB to the same body stud as the slave charger (Figure 10). Position the ground strap so that it does not interfere with the seat bottom frame mounting point that is next to the ground stud.

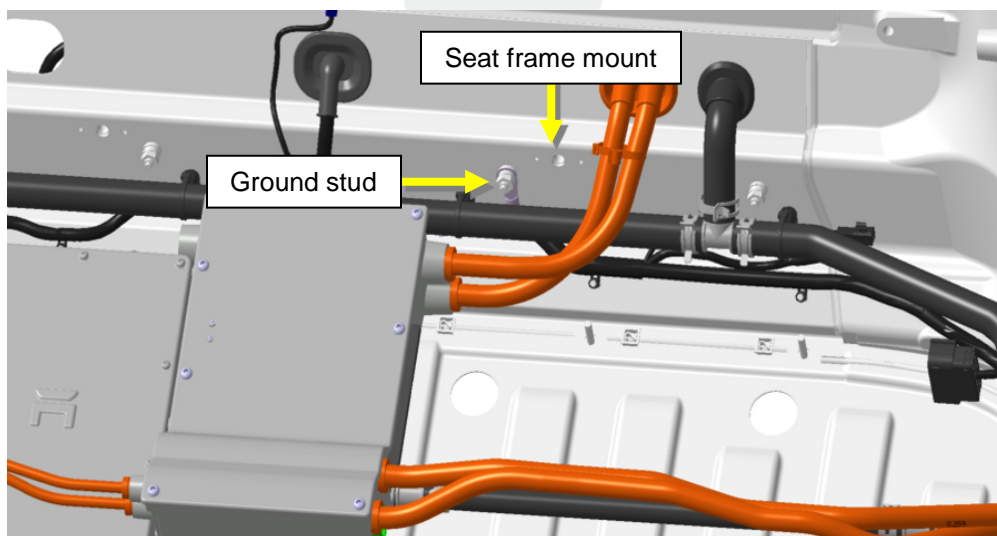

**Figure 10**

22. Install the 3 connectors from the HVJB to the slave charger (Figure 9).
23. Use a clippable hose ring to wrap around the coolant hose where it contacts the rear LH side corner of the charger. Copy the placement of the same piece on the master charger.
24. Reconnect the harness connector to the side of the slave charger.

25. Move the coolant hose back into its former location (see step 7).
26. Fasten the 2 clips that secure the charger coolant hose to the body.
27. Reinstall the 2 quick connectors that secure the charge port cables to the HVJB body (Figure 5). Move the cables back into their former location.
28. Reinstall the 2 bolts that secure the positive and negative charge port cables at the HVJB (torque 9 Nm).
29. Reinstall the HVJB cover.
30. Connect the slave charger low voltage connector on the outboard side of the charger.

**NOTE:** Do not reinstall the 2<sup>nd</sup> row seat cushion frame yet.

## Change Vehicle Configuration for Dual Chargers

1. Reconnect the 12V battery.
2. Reconnect the 12V external charger.

**NOTE:** Even though the 12V battery should draw power from the HV system, it is necessary to connect a 12V power supply in case there is a problem that prevents the contactors from closing.

3. In Toolbox, select Views > HV Electronics > Charger Config.
4. Verify that both “Master Charger” and “Slave Charger” icons are green. If not, click the Refresh button. If both icons are still not green, repeat the steps in the “Configure the New Slave Charger” section of this document.
5. Verify the information on the Update Vehicle Charger Config button is correct, then click the button (Figure 11).

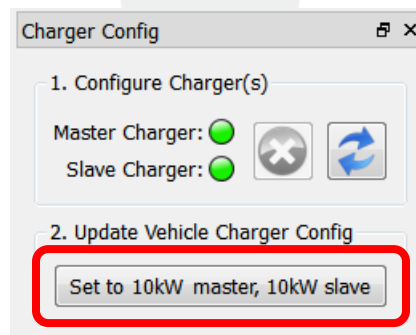

**Figure 11**

6. Perform a full firmware update.

**NOTE:** Leave the laptop connected to the vehicle.



## Reinstallation and Coolant Purge

1. Perform the coolant purge procedure (refer to Service Manual procedure 18300000).
2. Reinstall all components that were removed for access.
3. Test drive the vehicle and verify that there are no alerts.
4. Charge the vehicle at above 40 A for at least 5 minutes and verify that there are no alerts.

---

**Affected VIN(s)** North American Model S vehicles built before October 16, 2013, and from November 1, 2013–December 2, 2013.

**NOTE:** This is a simplified summary of the affected VIN list. Refer to the VIN/Bulletin Tracker or Customer/Vehicle profile to determine applicability of this bulletin for a particular vehicle.

For feedback on the accuracy of this document, email [ServiceBulletinFeedback@teslamotors.com](mailto:ServiceBulletinFeedback@teslamotors.com).