



Inspect Seat Belt Pre-Tensioner Rear Bracket Bolt, Model S

Classification	Campaign Bulletin	Section/Group	20 - Safety and Restraint	Country/Region	United States
Year	2015	Model	Model S	Version	All

Bulletin Classification: *This campaign bulletin addresses a known non-safety-related condition and provides recommended technical diagnosis and repair procedures. Apply this procedure to all vehicles in the affected VIN range listed. These instructions assume knowledge of motor vehicle and high voltage electrical component repairs, and should only be executed by trained professionals. Tesla Motors assumes no liability for injury or property damage due to a failure to properly follow these instructions or repairs attempted by unqualified individuals.*

Condition

On some vehicles, the seat belt pre-tensioner rear bracket bolt might have been assembled using a higher torque than specified by the bolt grade. The bolt is not critical for pre-tensioner performance, but in order to ensure a bolt torque consistent with the bolt specification, these bolts should be discarded and replaced, if necessary.

Correction

On each side of the vehicle, inspect the bolt that secure the seat belt pre-tensioner support bracket to the body of the vehicle. If necessary, replace the bolt(s).

Correction Description	Correction	Time
Vehicle Inspection Only; Seat Belt Pre-Tensioner Rear Bracket Bolt Replacement Not Required, Model S	S011520003	0.30
Replace LH Seat Belt Pre-Tensioner Rear Bracket Bolt, Model S	S021520003	0.35
Replace RH Seat Belt Pre-Tensioner Rear Bracket Bolt, Model S	S031520003	0.35
Replace LH and RH Seat Belt Pre-Tensioner Rear Bracket Bolts, Model S	S041520003	0.40

Required Part(s):	Part Number	Description	Quantity
	If necessary: 1079496-00-A	BOLT, M6 x 25	1-2

These part numbers were current at the time of publication. Use the revisions listed or later, unless otherwise specified in the Parts Manual.

Procedure

1. Remove the LH lower B-pillar trim panel (refer to Service Manual procedure 15184401).
2. Inspect the bolt that secures the seat belt pre-tensioner support bracket to the body of the vehicle (Figure 1).
 - If the bolt is black, reinstall the LH lower B-pillar trim panel and repeat steps 1-2 on the RH side of the vehicle.
 - If the bolt is silver, continue to the next step.

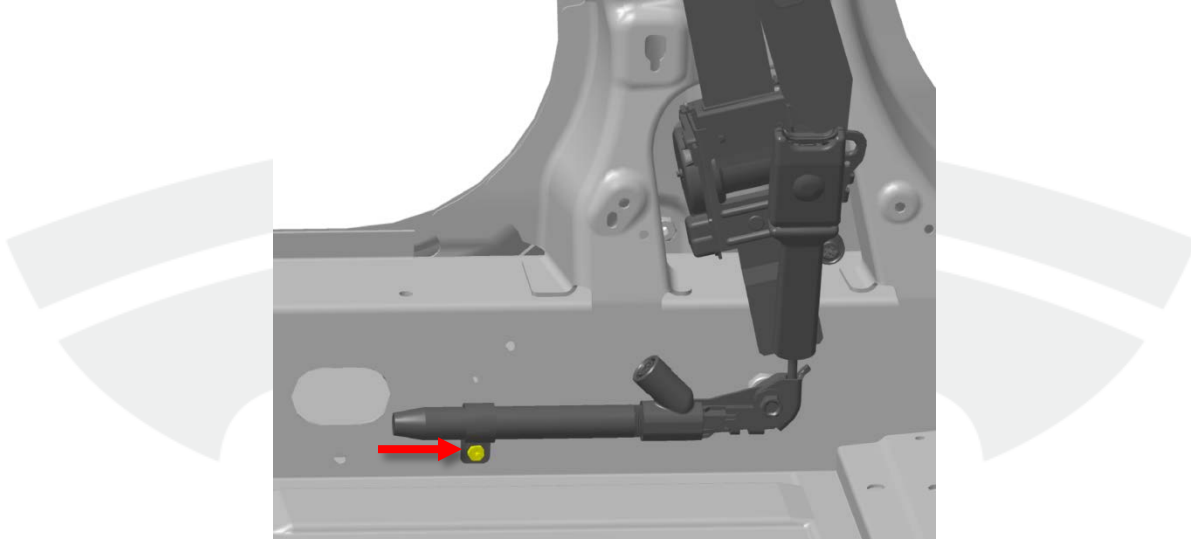

Figure 1

3. Remove and discard the bolt.

NOTE: There is a push nut on the bolt. Discard the push nut and install the new bolt without a push nut.

4. Install a new bolt (torque 5 Nm).
5. Reinstall the LH lower B-pillar trim panel.
6. Repeat the procedure on the RH side of the vehicle.

Affected VINs This information is for reference purposes only. This list is not intended to be the sole information source for updates.

5YJSA1E19FF118152
5YJSA1E1XFF118287
5YJSA1E14FF118818

For feedback on the accuracy of this document, email ServiceBulletinFeedback@teslamotors.com.