



Steering Wheel Clicking Sound

Classification Repair Bulletin **Section/Group** 32 - Steering **Country/Region** All

Year All **Model** Model S **Version** All

Bulletin Classification: *This repair bulletin provides instructions and guidelines for a noted condition or a customer concern. The information provided can address a broad range of known or perceived issues with the operation of Tesla vehicles. This bulletin might not be VIN-specific. These instructions assume knowledge of motor vehicle and high voltage electrical component repairs, and should only be executed by trained professionals. Tesla Motors assumes no liability for injury or property damage due to a failure to properly follow these instructions or repairs attempted by unqualified individuals.*

This Service Bulletin supersedes SB-16-32-001, dated 22-Feb-16. Each content change is marked by a vertical line in the left margin. Discard the previous version and replace it with this one.

Condition

Some customers might complain about a clicking sound when turning the steering wheel at low speed, leading to a perceived quality issue.

Correction

Upon customer complaint, install friction shims between the steering rack and subframe. Replace the steering rack bolts.

Required Part(s):	Part Number	Description	Quantity
	1051424-00-A	BOLT HF M14x78 PC109	2
	1080982-00-A	FRICION SHIM,M14x17.5x0.16,STL,GRADE 25	2

Shop supplies:

Alcohol wipes (1054788-00-A or equivalent)

These part numbers were current at the time of publication. Use the revisions listed or later, unless otherwise specified in the Parts Manual.

Correction Description	Correction	Time
SB-16-32-001 Not Applicable	S011632001	0.00
Install Shims and Replace Steering Rack Bolts To Prevent Steering Wheel Clicking (Rear Wheel Drive Vehicle)	S021632001	0.65
Install Shims and Replace Steering Rack Bolts To Prevent Steering Wheel Clicking (Dual Motor Vehicle)	S031632001	0.55

Procedure

1. Remove the underhood storage unit:

- **RWD vehicles:** Refer to Service Manual procedure 15240701.
- **Dual Motor vehicles:** Refer to Service Manual procedure 15242002.

2. Remove and discard the 2 bolts that secure the steering rack to the subframe (Figure 1).

NOTE: Some vehicles have a washer between the subframe and steering rack on one side of the vehicle. Note whether the washer is installed on the LH or RH side of the subframe. Remove and retain this washer; it will be reinstalled in a later step.

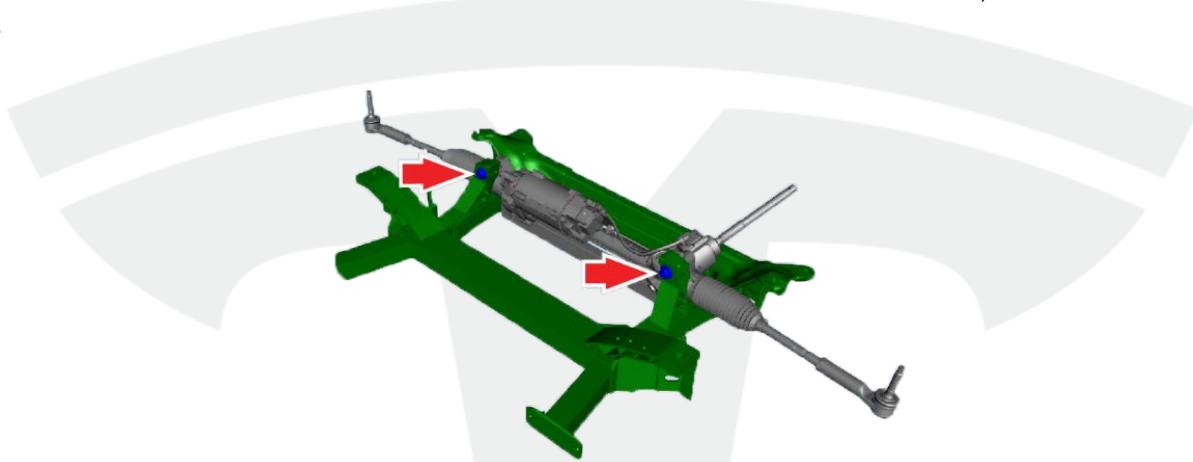

Figure 1

3. Use an alcohol wipe to clean the mating surfaces between the steering rack and subframe. If there is excessive buildup between the mating surfaces, use a razor blade to remove the buildup.

⚠ WARNING: To avoid personal injury, wear cut-resistant gloves during this step.

4. If a washer was removed earlier in the procedure, reinstall it between the steering rack and subframe on the correct side of the vehicle, as noted in step 2.

5. On both sides of the vehicle, install a friction shim between the steering rack and the subframe. If the shim is rectangular with rounded corners (Figure 2), ensure that the longer side of the shim faces outboard.

NOTE: If a washer is present between the steering rack and subframe, install the shim between the washer and subframe.

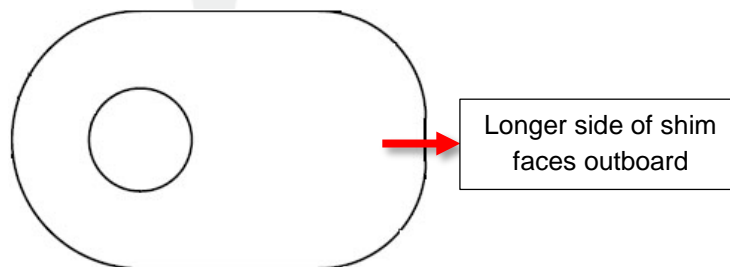

Figure 2

6. Install new bolts to secure the steering rack to the subframe (torque 175 Nm).

7. Reinstall all components that were removed for access.
8. Perform an alignment check (refer to Service Manual procedure 31002100).

For feedback on the accuracy of this document, email ServiceBulletinFeedback@teslamotors.com.

