



Wrinkles in Front Seat Upholstery

| | | | | | |
|-----------------------|-----------------|----------------------|---------------------|-----------------------|---------------|
| Classification | Repair Bulletin | Section/Group | 13 - Seats | Country/Region | All |
| Year | 2016-2017 | Model | Model S, Model X | Version | Premium Seats |

Bulletin Classification: *This repair bulletin provides instructions and guidelines for a noted condition or a customer concern. The information provided can address a broad range of known or perceived issues with the operation of Tesla vehicles. This bulletin might not be VIN-specific. These instructions assume knowledge of motor vehicle and high voltage electrical component repairs, and should only be executed by trained professionals. Tesla assumes no liability for injury or property damage due to a failure to properly follow these instructions or repairs attempted by unqualified individuals.*

This Service Bulletin supersedes SB-17-13-002, dated 14-Jul-17. Each content change is marked by a vertical line in the left margin. Discard the previous version and replace it with this one.

Condition

On some Model S and Model X vehicles, the connection of the hook-and-loop material that secures the seat upholstery to the seat cushion foam might weaken, causing the upholstery to gather and cause wrinkles.

Correction

Perform this procedure if diagnosis indicates that the appearance of excessive upholstery or wrinkles can be fixed by installing retention rods inside the seat upholstery and using cable ties to secure the upholstery to the seat cushion foam to keep the upholstery taut.

⚠ CAUTION: Do not perform this procedure on seats that have an Occupant Classification System (OCS) sensor. Vehicles equipped with an OCS sensor have a visible tube on the underside of the seat assembly (Figure 1).

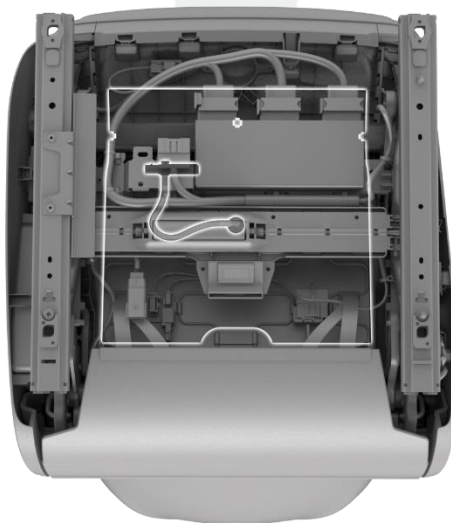

Figure 1 (OCS tube highlighted)

NOTE: Only perform this procedure on Model S with option code FR04 and Model X with option code FR01 or FR02.

| Correction Description | Correction | Time (Model S) | Time (Model X) |
|---------------------------------------------------------------------------------|------------|----------------|----------------|
| SB-17-13-002 Not Applicable | S011713002 | 0.00 | 0.00 |
| Vehicle Inspection Only; Seat Upholstery Wrinkles Within Acceptable Limits | S021713002 | 0.05 | 0.05 |
| Install Retention Wires Inside Front LH Seat And Secure Seat Upholstery | S031713002 | 0.75 | 0.95 |
| Install Retention Wires Inside Front RH Seat And Secure Seat Upholstery | S041713002 | 0.75 | 0.95 |
| Install Retention Wires Inside Front LH and RH Seats And Secure Seat Upholstery | S051713002 | 1.35 | 1.75 |

| Required Part(s): | Part Number | Description | Quantity |
|-------------------|--------------|-----------------------------------|----------|
| | 1134593-00-A | RETENTION ROD, FRONT SEAT CUSHION | 2 or 4 |
| | 1134594-00-A | CABLE TIE, 280 MM | 8 or 16 |
| | 1134595-00-A | MOUNT, CABLE TIE, ADH/SCREW MOUNT | 8 or 16 |

Release Seat Base Cover

1. Prepare a padded area to place the seat on when it is removed from the vehicle.
2. Remove the affected seat from the vehicle (refer to Service Manual procedure 13040101). Place the seat upright on the padded surface.
3. Remove the front trim cover from the base of the seat (Figure 2).

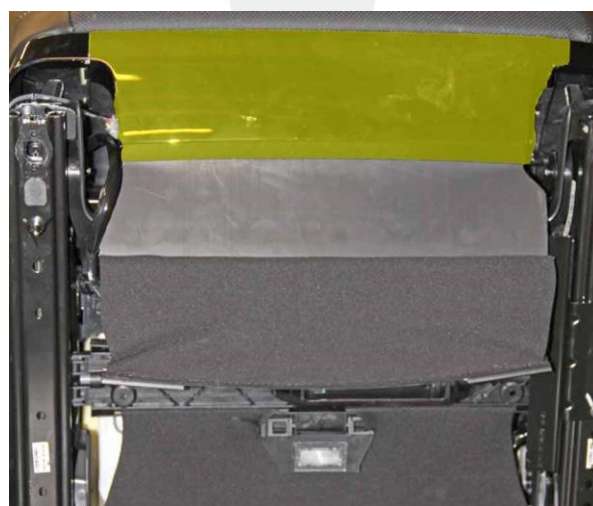

Figure 2 (Front trim cover highlighted)

4. Remove the LH and RH outer side covers (refer to Service Manual procedure 13074001).
5. Rotate the seat so that it rests on its back cover.

6. Use a pick or similar tool to release the rear lower cover from the underside of the seat (Figure 3).

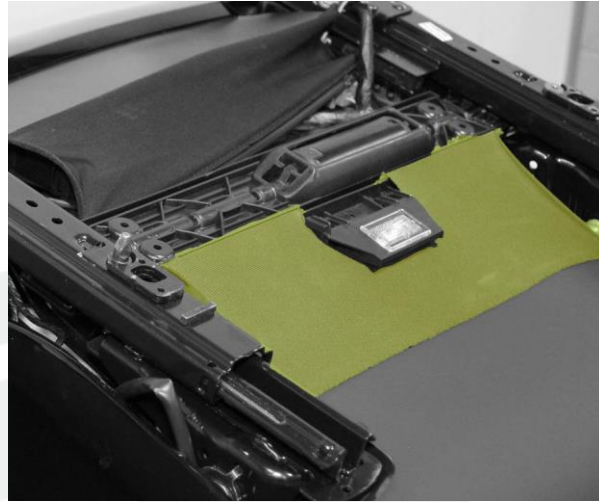

Figure 3 (Rear lower cover highlighted)

7. Use a pick or similar tool to release the front lower cover from the underside of the seat (Figure 4).

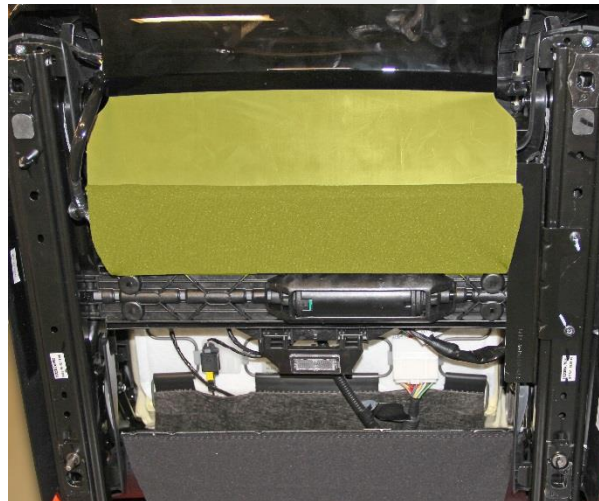

Figure 4 (Front lower cover highlighted)

8. Release the clips that secure the seat belt buckle trim panel to the seat frame (Figure 5).



Figure 5 (Seat belt buckle trim panel highlighted)

9. Release the J-clips that secure the seat upholstery to the cross wires on the flex mat (Figure 6).

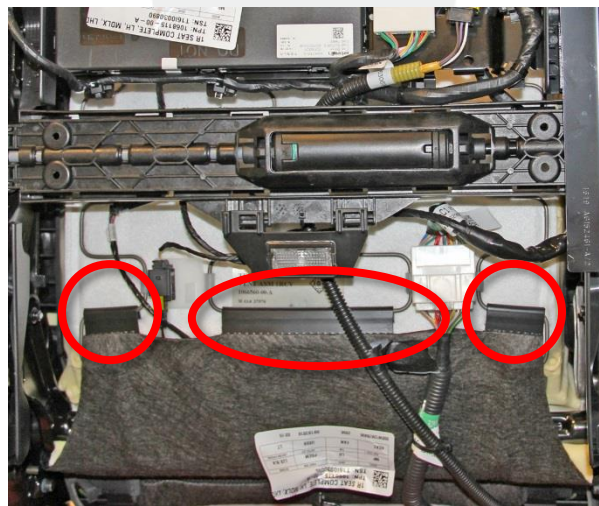

Figure 6

10. Starting from the inboard side of the seat and working around the seat edge, release the upholstery from the seat base (Figure 7).



Figure 7

11. Pull the seat base upholstery forward so that it is free from the junction of the seat base and seat back.

Install Retention Rods

1. Fold the LH edge of the seat base upholstery inboard to expose the strip of hook-and-loop material that secures the seat base upholstery to the foam cushion (Figure 8).



Figure 8 (Hook-and-loop material highlighted in yellow)

NOTE: The strip of hook-and-loop material is folded into a cylindrical channel. The following steps explain how to insert a retention rod inside the channel of hook-and-loop material.

2. Mark a location on the strip of hook-and-loop material in-line with the rearmost seam on the seat base upholstery (Figure 9).



Figure 9

3. Cut an 8 mm slit in the strip of hook-and-loop material at the location that was marked in the previous step (Figure 10).



Figure 10

4. Feed the rod through the hole in the hook-and-loop material towards the front of the seat (Figure 11).



Figure 11

5. Route a cable tie through a cable tie mount to create an assembly (Figure 12). Repeat this 3 times to create a total of 4 assemblies.



Figure 12

6. Mark 3 additional locations on the strip of hook-and-loop material (Figure 13):
 - In line with the forward-most seam on the seat base upholstery.
 - In line with the middle seam on the seat base upholstery.
 - Halfway between the forward-most and middle seams on the seat base upholstery.

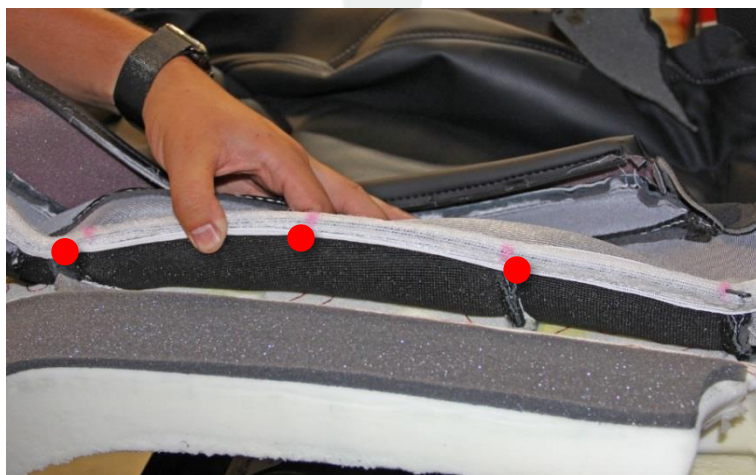

Figure 13

- Cut 8 mm slits in the strip of hook-and-loop material at the locations that were marked in the previous step.
- Align the seat base upholstery with the foam cushion. Note the location where the first hole into which the retention rod was inserted contacts the foam (Figure 14). Use a small flathead screwdriver or similar tool to make a hole through the foam (Figure 15). A cable tie will be inserted through this hole in a later step.



Figure 14

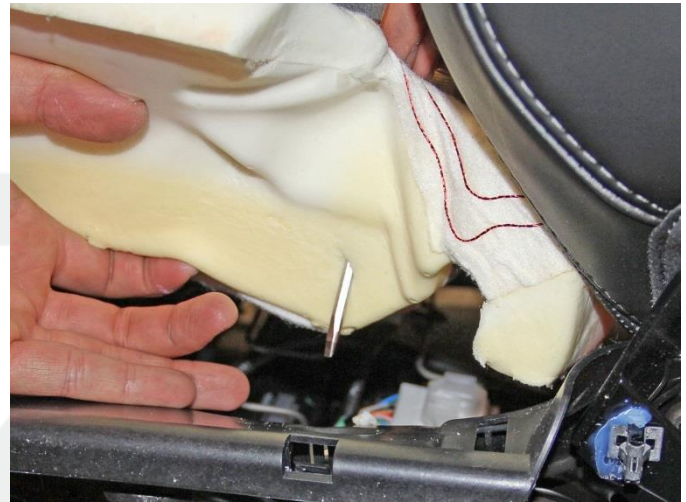

Figure 15

- Repeat the previous step for the 3 other locations that were marked on the strip of hook-and-loop material.
- Starting with the adhesive side of the cable tie mount facing the seat cushion foam, route a cable tie up through the rearmost hole in the foam and around the retention rod (Figure 16), then route it back through the hole in the foam. Loosely secure the cable tie, but do not fully tighten it.

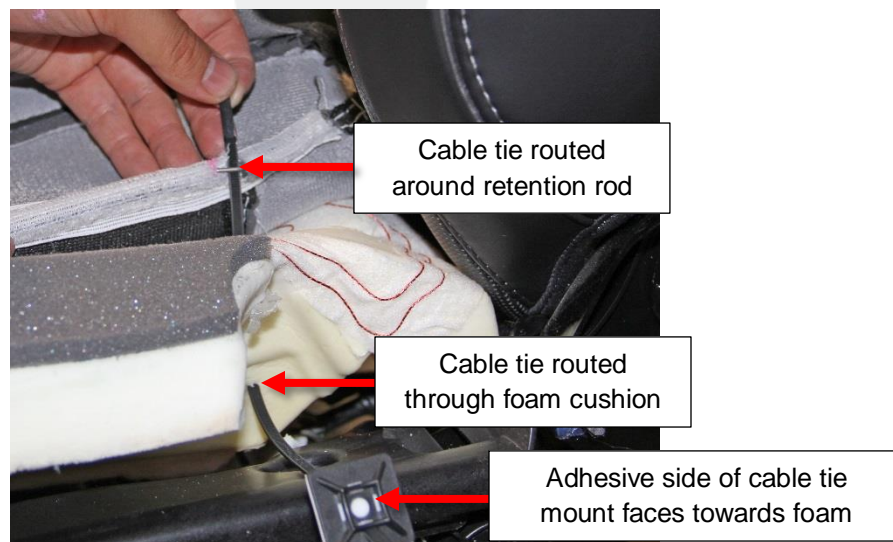

Figure 16

11. Repeat the previous step to install 3 additional cable ties and mounts (Figure 17).

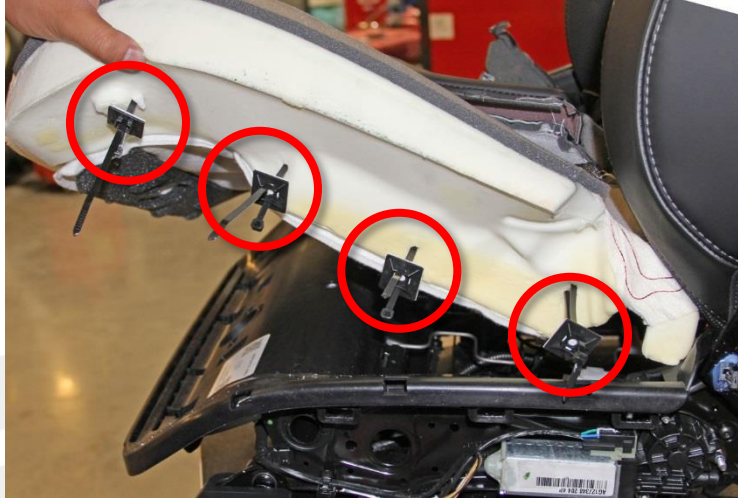

Figure 17

12. Fully tighten all cable ties. Remove and discard any excess tie.

13. Repeat steps 1-12 on the RH side of the seat.

14. Reinstall all seat components.

15. Reinstall the seat.

Affected VIN(s) All Model S vehicles with premium seats.
All Model X vehicles.

NOTE: This is a simplified summary of the affected VIN list. Refer to the VIN/Bulletin Tracker or Customer/Vehicle profile to determine applicability of this bulletin for a particular vehicle.

For feedback on the accuracy of this document, email ServiceBulletinFeedback@tesla.com.