



# Perform Coolant Air Purge For 60 Minutes

<b>Classification</b>	Campaign Bulletin	<b>Section/Group</b>	18 - Thermal Management	<b>Country/Region</b>	United States
<b>Year</b>	2017	<b>Model</b>	Model 3	<b>Version</b>	All

**Bulletin Classification:** This campaign bulletin addresses a known non-safety-related condition and provides recommended technical diagnosis and repair procedures. Apply this procedure to all vehicles in the affected VIN range listed. These instructions assume knowledge of motor vehicle and high voltage electrical component repairs, and should only be executed by trained professionals. Tesla assumes no liability for injury or property damage due to a failure to properly follow these instructions or repairs attempted by unqualified individuals.

## Condition

Some Model 3 vehicles were delivered with air in the cooling system.

## Correction

Purge air from the cooling system for a duration of 60 minutes.

Correction Description	Correction	Time
SB-17-18-006 Not Required	S011718006	0.00
Perform Coolant Air Purge For 60 Minutes	S021718006	0.10

## Procedure

**⚠ CAUTION:** Keep the level of coolant in the superbottle reservoir above that identified in Figure 1. Otherwise, air might be reintroduced into the cooling system, and will require a restart of the procedure at step 8.

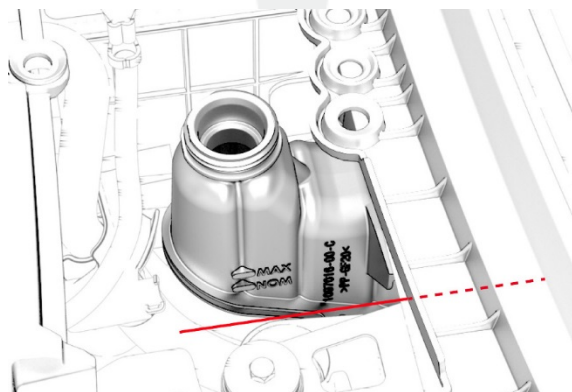

**Figure 1 (Minimum coolant level)**

**NOTE:** Make sure that the vehicle firmware version is 2017.32 or later, before performing this procedure.

1. Remove the cabin intake duct (refer to Service Manual procedure 18108402).
2. Release the clips that secure the HVAC plenum outer duct to the HVAC plenum inner duct, and remove the outer duct from the vehicle.
3. Remove the superbottle reservoir cap.
4. Fill the reservoir to the "MAX" level with coolant (Figure 1).
5. Connect a laptop with Toolbox 3 to the vehicle.
6. In the ToolBox 3 navigation panel, click **Manufacturing Tasks**.
7. In the "All Tasks" list, find **Thermal Fluid Fill/Drain Enable**, and click the Play button.
8. Fill the reservoir to the "MAX" level with coolant.
9. Start a 60 minute timer.
10. From the "Process" menu, select **COMMON ECU TASKS**.
11. In the "COMMON ECU TASKS" list, find **Coolant Air Purge** and click the Play button.

**NOTE:** Powering on the drive rails (for example, pressing the brake pedal), terminates the coolant air purge routine. If this happens, click the Play button to restart the coolant air purge routine.

**NOTE:** During the purge, the coolant pumps vary speed, and the 5-way valve alternates between series and parallel modes.

12. Monitor the coolant level during the air purge and fill to the "MAX" level as necessary.

 **CAUTION:** If air reintroduction occurs, go to step 8 and restart the 60 minute timer.

13. After successful completion of the coolant air purge routine, check the timer, and repeat steps 11 and 12 as necessary so that there is a total of at least 60 minutes of air purge.
14. If necessary, fill the reservoir to the "MAX" level with coolant.
15. Install the reservoir cap.
16. Install the HVAC plenum outer duct to the HVAC plenum inner duct, and fasten the clips that secure the outer duct to the inner duct.
17. Install the cabin intake duct (refer to Service Manual procedure 18108402).

---

**Affected VIN(s)** Affected Model 3 vehicles built before approximately August 31st, 2017.

**NOTE:** This is a simplified summary of the affected VIN list. Refer to the VIN/Bulletin Tracker or Customer/Vehicle profile to determine applicability of this bulletin for a particular vehicle.

For feedback on the accuracy of this document, email [ServiceBulletinFeedback@tesla.com](mailto:ServiceBulletinFeedback@tesla.com).