

TC-8 DS

Description and Installation Manual

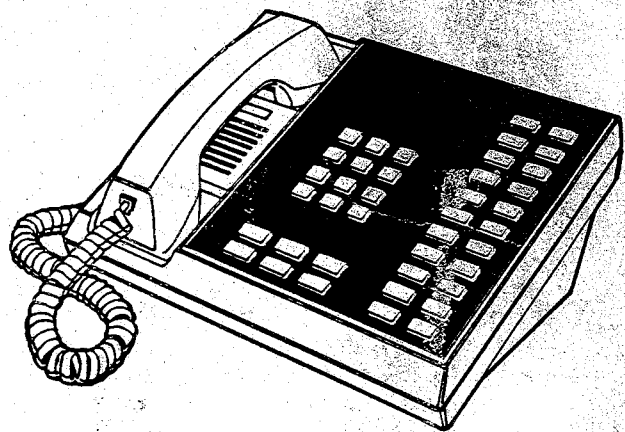

TIE/communications, Inc.

TIE PRACTICE TP00120

TC-8 DS

Description and Installation Manual

Draft 0-5

May 13, 1983

This manual has been developed by TIE/communications, Inc. It is intended for the use of its customers and service personnel.

Any comments or suggestions for improving this manual would be appreciated. Forward your remarks to:

TIE/communications, Inc.
5 Research Drive
Shelton, CT 06484

Attention: Manager, Technical Publications

The information in this manual is subject to change. While every effort has been made to eliminate errors, the company disclaims liability for difficulties arising from interpretation of the information contained herein.

REVISION CONTROL

REVISION	DATE	CHANGE
0-1	8 APR 83	First Draft
0-2	26 APR 83	First published draft.
0-3	6 MAY 83	Updated manual to include new information.
0-4	11 MAY 83	Revised with minor corrections prior to release for distribution.
0-5	13 MAY 83	Printed new draft for printing master. No change.

TABLE OF CONTENTS

SECTION 1 General Description

The General Description Section provides basic information about the TC-8 DS Electronic Key Telephone System. It summarizes the various components of a system, available extension instruments, specifications, site requirements, and Federal Communications Commission/telephone company requirements.

CONTENTS	PAGE
1. INTRODUCTION1-1
2. SYSTEM DESCRIPTION1-1
Key Service Unit.1-2
Telephones.1-2
Attendant DSS Console1-2
3. SPECIFICATIONS1-2
4. SITE REQUIREMENTS.1-7
5. FCC AND TELCO REQUIREMENTS1-8
Notification To Telco1-8
FCC Approved Connectors1-8

Installation Classes1-8
Incidence Of Harm1-8

SECTION 2

Features

The Features Section provides detailed information on each of the features available on the TC8-DS Electronic Key Telephone System.

CONTENTS	PAGE
1. INTRODUCTION2-1
2. TELEPHONES2-1
Key Telephones2-1
DSS Console2-1
Single Line Telephone2-3
3. TYPES OF FEATURES2-3
Permanent2-3
Programmable2-3
Optional2-3
4. FEATURES2-3
Answering An Incoming Call2-3
Placing An Outside Call2-3
Microphone Mute2-4
Monitor2-4
Hold2-4
I-Hold2-5
Exclusive Hold2-5
I-Hold Reminder2-5
Exclusive Hold Recall2-5

Exclusive Hold Transfer2-5
Abandoned Call Release.2-5
Intercom Call2-6
Intercom Time Out2-6
Direct Station Selection.2-6
Alternate Point Answer.2-7
Transfer.2-7
Paging.2-8
Meet-Me-Conference.2-9
Meet-Me-Answer on Paging.2-9
Non-Paging Station.2-9
Conference Call2-9
Last Number Redial.	2-10
Save Last Number.	2-10
Station Speed Dial.	2-11
System Speed Dial	2-11
Queuing	2-12
Callback.	2-12
Message Waiting	2-13
Hotline	2-13
Do Not Disturb.	2-14
Executive Call Forward.	2-14
Barge-In.	2-14
Private Line.	2-15
Flash Key	2-15
Background Music.	2-15
Music On Hold	2-15

Toll Restriction.	2-16
"0" & "1" Toll Restriction.	2-16
Restricted Queue Groups	2-16
Off Premise Stations.	2-16
Power Failure Transfer.	2-16
Flexible Ringing.	2-16
Off Hook Tone Signaling	2-16
5. ATTENDENT FEATURES	2-17
Direct Station Selection.	2-17
Transfer.	2-17
Paging.	2-17
Message Waiting	2-17
PBX Call Ringing.	2-18
Alarm Repeating	2-18
Chain Calling	2-18
DSS Display with Freeze	2-19
DSS Override	2-19
Night Transfer.	2-19

SECTION 3 System Configuration

The System Configuration Section provides information to help the user configure the equipment to meet the particular needs of a customer. An Option Configuration Worksheet (OCW) is used to gather specific data used for ordering equipment and completing the Program Record Form in Section 4.

CONTENTS	PAGE
1. INTRODUCTION	3-1
2. DESCRIPTION OF COMPONENTS.	3-1
Key Service Unit.	3-1

Power Supply Unit3-1

Printed Circuit Boards.3-2

A-MPU-B Main Processor PCB.3-1

A-DMU Data Management PCB3-1

A-ILU Intercom Link PCB3-1

A-NMU Memory PCB.3-2

A-SSU Tone Sending PCB.3-2

A-LNU CO Line PCB3-2

A-SLU Key Interface PCB3-2

A-EPU External Page Interfece PCB3-2

A-PFU Power Failure PCB3-2

A-OPU Off Premise Station PCB3-2

3. COLLECTION OF DATA3-2

 System Options.3-2

 1. Number and Types And Of CO Line Required. . . . 3-3

 2. Type of Telephone Service Required.3-3

 3. PBX3-3

 4. Number of Required Stations3-3

 5. Paging.3-3

 6. Background Music.3-3

 7. Alarm System.3-3

 8. Queue Groups.3-3

 9. Unrestricted Queue Groups3-3

 10. Absorb Digits3-3

 11. Power Failure3-3

 System Configuration Worksheet.3-4

 1. Name of Station User.3-5

2. DSS Keys3-5
3. Type of Telephone3-5
4. CO lines Assigned for Day Ringing..3-6
5. CO lines Assigned for Night Transfer.3-6
6. Stations with Barge-In.3-6
7. Stations with Do Not Disturb.3-6
8. Restricted Queue Groups3-6
9. Class of Service.3-6
10. Executive Call Forward.3-6
11. Stations with Private Line.3-6
12. Stations with Hotline3-6
13. Stations to Receive Paging.3-6
Station Configuration Worksheet3-7
ORDER REQUIREMENTS3-8
Ordering Requirements3-8
PCB Configurations.3-9

SECTION 4

Program Record Form

The Program Record Form Preparation Section provides simple instructions for changing the information gathered on the Options Configuration Worksheet (Section 3) into programming data. The directions convert the selected options into codes to be entered on the 'Program Entry' column of the Program Record Form. This Program Record Form is also retained as a job record.

CONTENTS	PAGE
1. INTRODUCTION4-1
Program Record Form Preparation Instructions.4-1
Program Record Form4-13

SECTION 5

Installation

The Installation Section provides detailed step-by-step procedures for installing the component parts of an TC-8 DS Electronic Key Telephone System.

CONTENTS	PAGE
1. INTRODUCTION5-1
2. PREPARATION.5-1
Site Requirements5-1
Tools And Test Equipment.5-3
Equipment5-3
3. INSTALLATION5-3
4. KSU AND POWER SUPPLY INSTALLATION.5-4
Backboard Installation Check.5-4
5. INSTALLING PCBS.5-6
PCB Location.5-8
Strapping and Setting Switches on PCBS.5-10
6. STATION CABLING AND SYSTEM CONNECTIONS5-18
Station Cabling5-18
CO Line Connections5-22
Power Fail Cross Connections.5-22
Private Line Connections.5-24
Background Music Connections.5-24
External Paging Zone Connections.5-25
Alarm Connections5-25
7. STATION INSTALLION5-26
8. INSTALLATION CHECK5-26
9. RADIO FREQUENCY INTERFERENCE5-27

10. CONNECTING TELCO LINES5-28

SECTION 6 Programming

The Programming Section describes the programming procedures for the TC-8 DS system. This section is divided into four parts: preparation, system initialization, programming (using the Program Record Form from Section 4) and changes.

CONTENTS	PAGE
1. INTRODUCTION6-1
2. SYSTEM INITIALIZATION.6-1
3. PROGRAMMING.6-2

TC-8 DS

ELECTRONIC KEY TELEPHONE SYSTEM

SECTION 1, GENERAL DESCRIPTION

1. INTRODUCTION

1.01 The GENERAL DESCRIPTION Section provides basic information pertaining to the TC-8 DS Key Telephone system. It describes the various components of a system, available station instruments, system specifications, site requirements and Federal Communications Commission/telephone company requirements.

1.02 This paragraph is reserved for summarizing major revisions to this section.

2. SYSTEM DESCRIPTION

2.01 The TC-8 DS is an Electronic Key Telephone System (EKTS) with distributed processing that uses a Z80 microprocessor as the main processor and additional processors for task-sharing between the Main Processing Unit (A-MPU-B) and the station Printed Circuit Boards (PCBs). The system also uses space division matrix.

2.02 This system has a maximum capacity of 2 Direct Station Selection (DSS) consoles, 2 Busy Lamp Fields (BLF), 15 Line Ring Groups, 20 stations, each having DSS capabilities (except for single-line telephones), and 4 Intercom (ICM) talkpaths. The system accommodates 8 common CO lines, a combination of 4 Private Lines or Hotlines and Dual Tone Multi-Frequency (DTMF) or pulse signals on CO lines. Privacy is provided on all internal and external calls.

2.03 Up to five designated stations can provide service during a local power failure. Stations having a power fail key (TC-22PF) telephone can be used to make and receive calls in a power failure. Standard key telephones, when designated as PF stations, can only be used to receive calls during a power failure and must be equipped with an external ringer to provide an audible signal. These telephones operate normally in a power-on condition.

2.04 The following paragraphs provide a summary of the major components to be detailed in subsequent sections.

KEY SERVICE UNIT & POWER SUPPLY

2.05 The Key Service Unit (KSU) and Power Supply (PSU) for the TC-8 DS System are wall-mounted. The KSU is equipped with replaceable Printed Circuit Boards (PCBs) that control the system.

TELEPHONE INSTRUMENTS

2.06 The TC-8 DS System uses the following telephone instruments: TC-12, TC-22, TC-22 PF, Attendant DSS console and a standard single line telephone.

2.07 The electronic key telephone used in the TC-8 DS system is available in two configurations: TC-12 (Figure 1-1), and TC-22 (Figure 1-2). Each provides access to system features; however, the number of available DSS keys varies with the telephone used.

Single Line Telephone

2.08 A standard Single Line Telephone (Figure 1-3) can be used at an off-premise station or in case of power failure.

Attendant DSS Console

2.09 The Attendant DSS Console (TC-8/TC-12) (Figure 1-4) provides direct access to all stations and is required to program the system. The console has a Busy Lamp Field (BLF) that displays the status of each station. The console also has keys to access paging zones, night transfer, call transfer and message waiting.

3. SPECIFICATIONS

3.01 Refer to table 1-1 for technical specifications.

Table 1-1: TC-8 DS Specifications

CO/PBX Lines	8
Stations	20
Intercom Paths	4
Private Lines and/or Hot Lines	4
Attendant DSS Consoles	2 (each console uses 1 station position)
Cable Requirements:	2 twisted pair 1000 feet, 24AWG 1500 feet 22AWG
Power Requirements:	
Power Supply:	
Input:	115 VAC 60 Hz 350 watts
Output to KSU:	

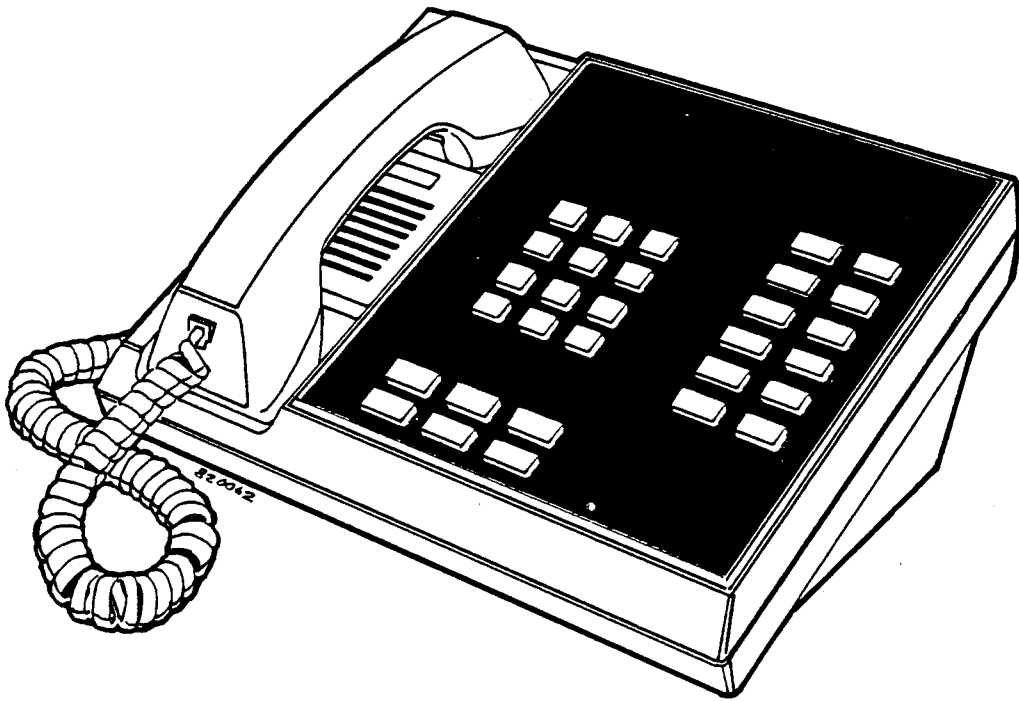

Figure 1-1 TC-12 ELECTRONIC KEY TELEPHONE

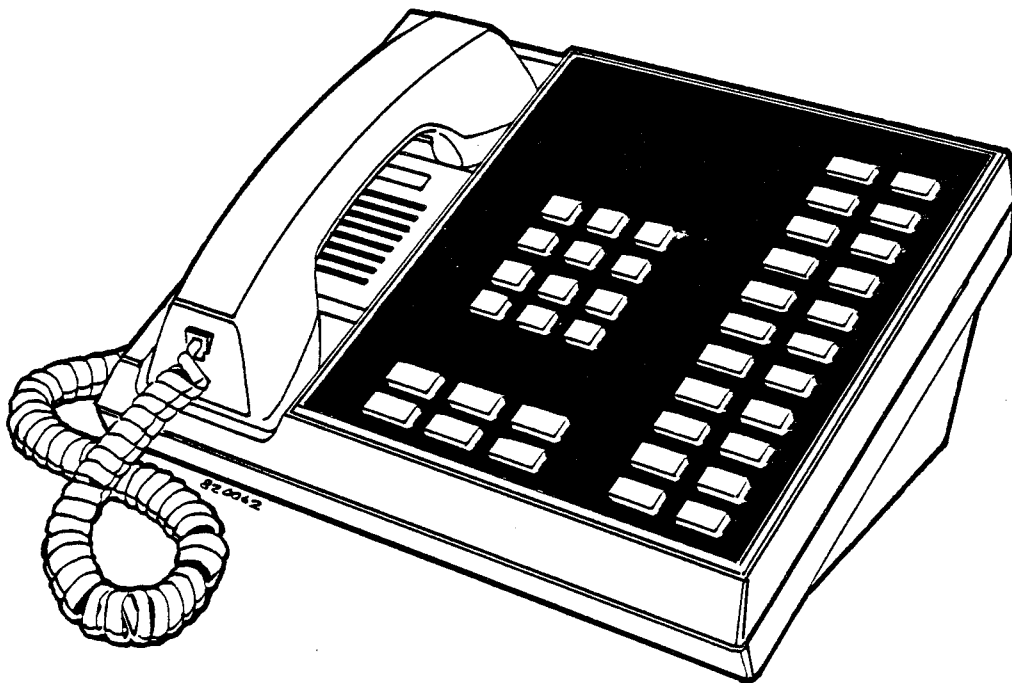

Figure 1-2 TC-22 ELECTRONIC KEY TELEPHONE



Figure 1-3 SINGLE LINE TELEPHONE

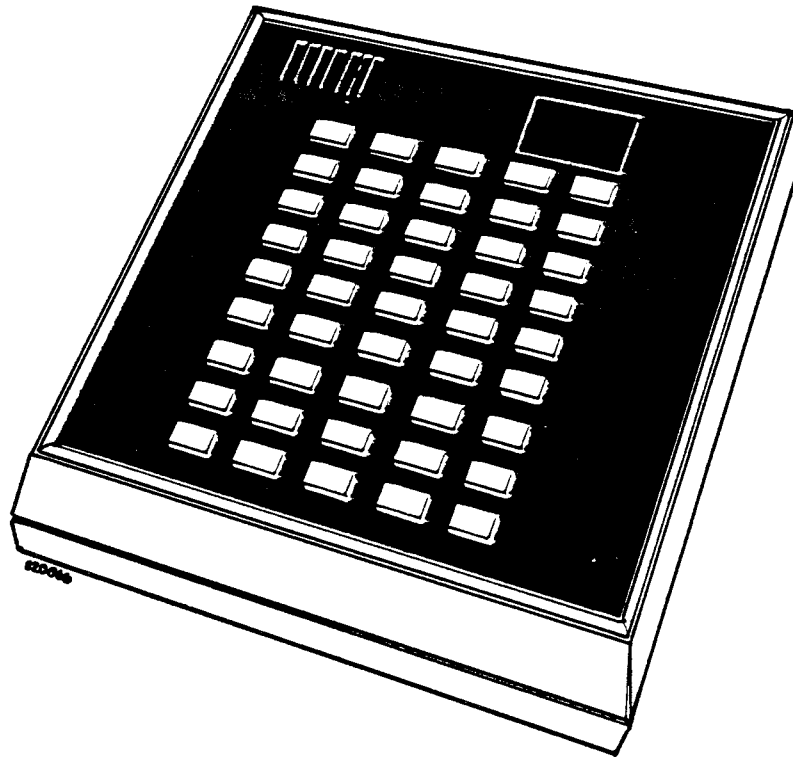

Figure 1-4 ATTENDANT DSS CONSOLE

Designation	Volts DC	Amperes DC
T30	31	4.5A
R24V	20	1.3A
T15V	14.7	1.8A
A15V	14.7	0.1A
S15V	14.7	0.1A
AB7.5V	7.4	10mA
SB7.5V	7.4	10mA
L5V	4.8	3.0A
ERS	*	20mA

Dimensions and weights:

KSU: 18.8" X 15.5" X 11.6 "
 Power Supply: 11.8" X 16.1" X 9.6" 55lbs.

Switching Principle:

Space division matrix with stored programs and space division switching and Z80 microprocessor.

Environmental operating conditions:

Temp: 4 to 38 degrees C. 40 to 100 degrees F.
 Humidity: 5-95% relative, condensing.

4. SITE REQUIREMENTS

4.01 The KSU should be installed in a clean, dry, secure location that prevents access by unauthorized personnel. This location should comply with Bell Functional Product Class Criteria of September, 1978 in publication PUB 48002 as stated in 3.4.3.2, paragraph C -- Indoors With Environmental Control. The room must have adequate ventilation and have a temperature range of 4 to 38 degrees C (40 to 100 degrees F) with 5 to 95% noncondensing relative humidity.

NOTE: System component life is related to operating temperature. LOWER TEMPERATURE = HIGHER RELIABILITY.

4.02 The installation site should have ample room to mount the KSU and PSU on the wall along with the necessary connecting blocks and any ancillary equipment. The installation site should not be located near dry copiers (static electricity), heavy machinery or in an area likely to be flooded (basement level).

4.03 The customer must provide a dedicated three-wire 115VAC, 60Hz 15 ampere circuit. A separate earth ground is required in addition to the third-wire ground on the AC circuit. If a music source or an optional external paging system is to be installed, it must be connected to an AC circuit other than the dedicated AC line.

4.04 The equipment generates and is susceptible to radio frequency energy. Refer to SECTION 5, for details.

5. FCC AND TELCO REQUIREMENTS

5.01 Rules and regulations for the operation and installation of privately owned telephone equipment have been established by the Federal Communications Commission (FCC). According to Part 68 (Connection of Terminal Equipment to the Telephone Network) and its amendments, several actions are required before and during installation of customer-provided telephone equipment. These actions include the following:

Notification to Telco

5.02 As owner of this telephone system, you must give the following information to the operating telephone company before connecting or disconnecting it:

1. Sufficient notice of your intention to use privately owned telephone equipment.
2. The particular lines to be used (telephone numbers xxx-xxxx through xxx-xxxx).
3. Model: TC-8
FCC Registration Number: BJ286G-68581-KF-E

Ringer Equivalence: 0.4B

Power Failure Telephone TC-22 PF
Ringer Equivalence: 1.3B

Certification of Installer

5.03 Connection of this system to telephone company lines must be made with FCC approved plugs and jacks. When the system is equipped with power failure the installer must be certified. Classes for certification are available through TIE/communications, Inc. and its Regional Offices.

Incidence of Harm

5.04 If customer-provided equipment is causing harm to the telephone network, the telephone company must, whenever practical, notify the customer that service may be temporarily discontinued. The telephone company must also attempt to inform the customer before actually disconnecting service. The telephone company must provide customers with an opportunity to correct the problem and must advise customers of their right to bring complaint procedures before the FCC.

TC-8 DS

ELECTRONIC KEY TELEPHONE SYSTEM

SECTION 2, FEATURES

1. INTRODUCTION

1.01 The FEATURES section provides information on the features of the TC-8 DS System. This section defines the features by their use, describes the telephones and provides instructions for using the features.

1.02 This paragraph is reserved for summarizing major revisions to this section.

2. TELEPHONE INSTRUMENTS

2.01 The TC-8 DS System uses the following telephones: TC-12, TC-22, TC-22 Power Failure Telephone (PF), Attendant DSS Console and Single Line Telephone.

2.02 Key telephones include the TC-12, TC-22 and the TC-22 Power Failure Telephone (Figure 2-1). These telephones contain a loudspeaker for tone signaling and a microphone for Handsfree (HF) Answerback during intercom calls. In addition to the standard dial pad, there are keys that provide access to CO lines, system and station features, and special functions. Various keys are equipped with an LED to indicate the status of the call or feature. Visual and audible signals provide various tone and flash patterns that distinguish outside, Intercom (ICM) and paging calls (Tables 2-1 and 2-2). A volume control adjusts the loudspeaker and music/paging volume. The TC-22 Power Failure Telephone provides circuitry required for power failure operation and is available in two configurations. The TC-22 Power Failure Tone (PFT) Telephone is used during a power failure in systems requiring DTMF signaling. The TC-22 Power Failure Pulse (PFP) Telephone is used during a power failure in systems requiring pulse signaling.

2.03 The Attendant DSS Console has a Busy-Lamp-Field (BLF) providing the attendant with the status of each station, DSS keys for direct access to all the stations, paging keys for access to internal and external paging zones and night transfer and message waiting. The console is also equipped with a digital display that indicates calls requiring attendant processing.

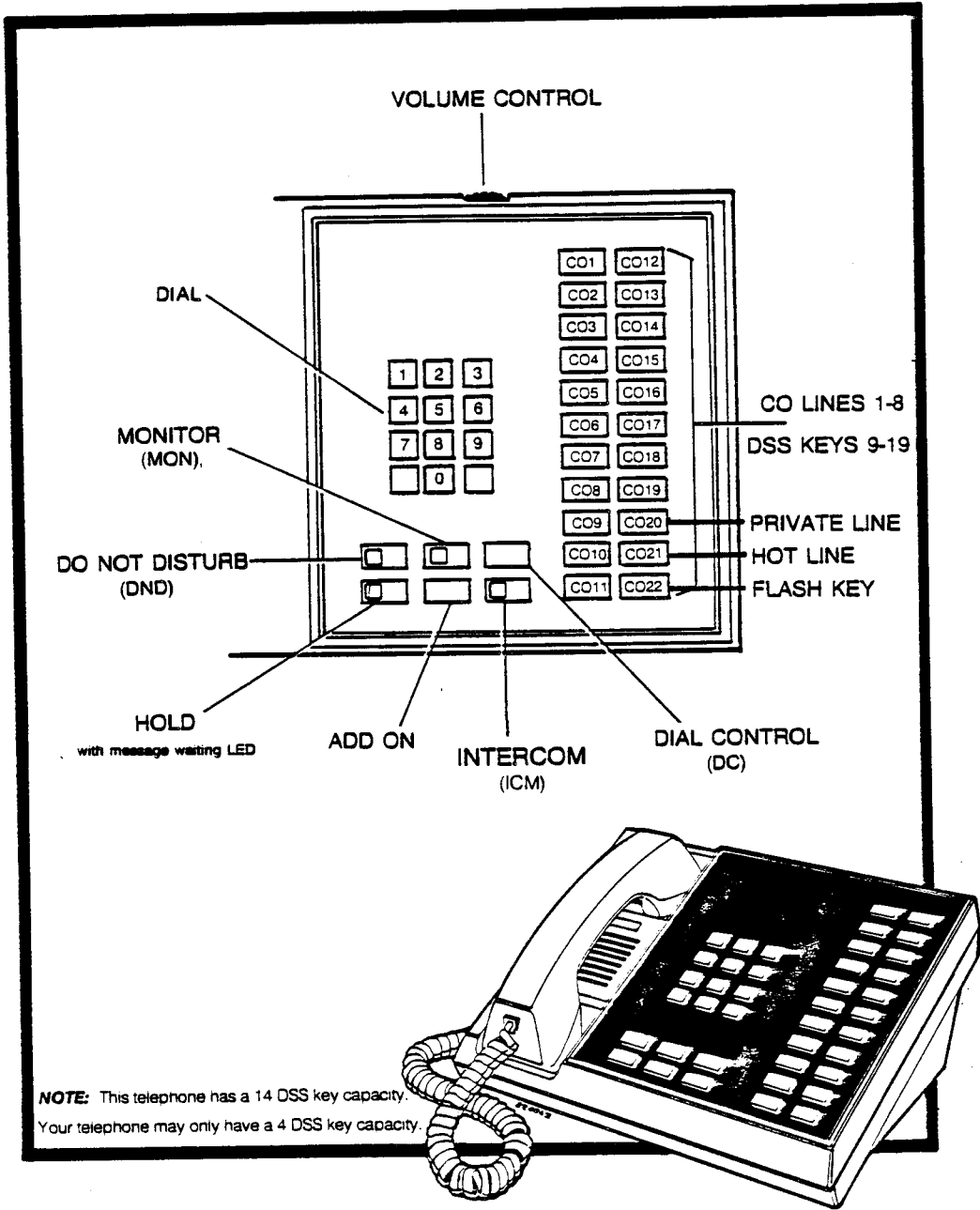

Figure 2-1 TC-22 ELECTRONIC KEY TELEPHONE

2.04 The single line telephone can be used at an off-premise station or in case of a power failure. Refer to Section 9, OPTIONAL EQUIPMENT, for installation and operation of the single line telephone as an off premise station. Refer to Section 5, INSTALLATION, for operation of the single line telephone as a power failure station.

3. TYPES OF FEATURES

3.01 Each feature is one of three types: permanent, programmable or optional. The following paragraphs describe each type.

3.02 Permanent features are intrinsic to the system hardware and cannot be altered by programming.

3.03 There are two programmable types of features, system-programmable and user-programmable.

3.04 Optional features require the installation of additional equipment.

4. FEATURES

4.01 The following paragraphs provide instructions for operating features from the TC-12 and TC-22 telephones.

ANSWERING A CALL

4.02 Incoming calls can be answered at any station. Incoming calls provide a distinctive signal and flash rate on the line key associated with the incoming call. Programming determines which stations receive the signal.

To answer a call:

- *Lift handset.
- *Press flashing line key.

PLACING AN OUTSIDE CALL

4.03 Outside calls can be initiated from any station providing programming for the station does not restrict the outgoing call.

To Place a Call:

- *Lift handset.
- *Press idle CO Line key.
- *Dial the telephone number.

MICROPHONE MUTE

4.04 Microphone Mute is a permanent feature that provides privacy at a station in the Handsfree Answerback mode during an Intercom (ICM) conversation. While engaged, Microphone Mute disables the microphone and prevents a calling party from hearing what is being said at that station.

To activate Microphone Mute while in the Handsfree Answerback mode:

-*Press DND key.†

† If station is programmed for Do Not Disturb, press DND key twice.

To return to Handsfree Answerback mode:

-*Press DND key.

MONITOR

4.05 Monitor is a permanent feature which permits a user to dial a number without lifting the handset. It also allows the user, while on hold from an outside party, to monitor the call with the handset on hook. The user can hear through the telephone speaker when the outside party returns to the call, but must lift the handset to talk to the outside party.

To dial a call without lifting handset:

-*Press the MON key.
-*Press idle CO Line key.
-*Dial number.
-*Lift handset to talk and be heard.

To monitor while on hold:

-*Press MON key.
-*Hang up handset.

To disengage the MONITOR feature:

-*Lift handset or press MON key to disconnect.

HOLD

4.06 Hold is a permanent feature to place a call in a temporary waiting condition. There are two types of Hold: I-Hold and Exclusive Hold.

I-Hold

4.07 I-Hold is a common hold. A call placed on I-Hold can be answered at any station in the system. The appropriate line provides an I-Hold indication by flashing fast at the telephone where the call was placed on hold. The line flashes more slowly at all other telephones.

To put call on hold:

-*Press HOLD key.

Exclusive Hold

4.08 Exclusive Hold places a call on hold and prevents that call from being answered at any other station. The appropriate line key provides a distinctive indication at the telephone where the call was placed on hold. Other telephones receive a steady line busy indication. The call can only be retrieved at the station where the call was originally put on hold.

To put a call on Exclusive Hold:

-*Press HOLD key twice.

I-HOLD REMINDER

4.09 I-Hold Reminder is a programmable feature which provides a timed reminder signal for calls left on hold by a station for longer than a programmed amount of time.

EXCLUSIVE HOLD RECALL

4.10 Exclusive Hold Recall is a programmable feature which provides a recall signal should a call be left on Exclusive Hold longer than a programmed amount of time.

EXCLUSIVE HOLD TRANSFER

4.11 Exclusive Hold Transfer is a programmable feature that transfers a call left on Exclusive Hold back to the attendant after a programmed recall time.

ABANDONED CALL RELEASE

4.12 Abandoned Call Release is a permanent feature which returns a line to an idle condition if an outside party waiting on hold hangs up. This occurs when a momentary open-loop disconnect of 90 milliseconds or more is given from the telco office.

INTERCOM

4.13 The Intercom feature is used to call another station. Key telephones have an ICM key that illuminates when placing intercom calls. Calls can be placed so that the called party answers handsfree or privately, with the handset.

To place an intercom call that can be answered handsfree:

- *Lift handset.
- *Press ICM key.
- *Dial station number.
- *Wait for splash tone and then speak.

NOTE: A double splash tone is heard when the called station is in the microphone mute mode.

To place an intercom call that must be answered with the handset:

- *Lift handset.
- *Press ICM key.
- *Dial station number.
- *Dial 1.

Handsfree Reply

To answer a Handsfree Intercom Call:

- *Answer voice announcement through microphone.

Private Reply

To answer an Intercom ring signal, or for a private conversation when currently in the handsfree mode:

- *Lift handset.
- *Press ICM key.

INTERCOM TIMEOUT

4.14 Intercom Timeout is a permanent feature providing a forced release of stations that access an ICM link, but do not dial within five seconds. This prevents an ICM link from being accidentally unavailable.

DIRECT STATION SELECTION

4.15 Key telephones have keys which function as Direct Station Selection (DSS) keys to provide rapid intercom access to a particular station. Fourteen station numbers can be assigned at the TC-22 key telephone. Four numbers can be assigned at the TC-12 key telephone. The number of keys available for use as DSS is affected by private line, hotline and flash key assignments. Line keys 9-22 can function as the DSS keys on the TC-22 telephone and line keys 9-12 can function as DSS keys on the TC-12 telephone.

To program a DSS key:

- *Lift handset.
- *Press DC key.
- *Press desired DSS key.
- *Dial station number.
- *Press DC key.

To place an intercom call using Direct Station Selection:

- *Lift handset.
- *Press appropriate DSS key.

ALTERNATE POINT ANSWER

4.16 Alternate Point Answer is a permanent feature which permits an ICM call to be answered from a station other than the called station.

To answer a call to another station:

- *Lift handset.
- *Dial ICM number of called station.

TRANSFER

4.17 Transfer is a permanent feature used to send an outside call from one station to another. A call on a common CO line can be transferred using the dial intercom or the DSS keys. The station where the transfer was originated will receive a reminder tone if the called station does not answer after a programmed time.

To transfer a call using the dial intercom:

- *Press ICM key. Call placed on Hold.
- *Dial station number
- *Announce transfer and line number.

The station that initiated the transfer receives an I-Hold Reminder signal if the call is unanswered after a programmed period of time.

To transfer a call using the DSS keys:

- *Press appropriate DSS key. Call placed on Hold.
- *Announce transfer and line number.

The station that initiated the transfer will receive an Exclusive Hold Recall signal if the call is unanswered after a programmed time period.

PAGING

4.18 Paging is a programmable feature. There are three types of paging: All Call, Internal Zone Page and Optional External Paging.

4.19 All Call paging is broadcasted to all speakers and stations programmed to receive paging announcements.

To use All Call:

- *Lift handset.
- *Press ICM key.
- *Dial 80.
- *Make announcement.
- *Hang up.

4.20 Internal Zone Page provides paging to a select group of stations.

To use Zone Page:

- *Lift handset.
- *Press ICM key.
- *Dial desired zone (81 - 84)
- *Make announcement.
- *Hang up.

Zones:

- 81 Zone 1
- 82 Zone 2
- 83 Zone 3
- 84 Zone 4

4.21 External Paging requires optional customer provided speakers or equipment.

To use External Zone Page:

- *Lift handset.
- *Press ICM key.
- *Dial desired zone (85, 86).
- *Make announcement.
- *Hang up.

Zones:

- 85 External Zone 1
- 86 External Zone 2

MEET-ME-CONFERENCE

4.22 Meet-Me-Conference is a programmable feature allowing up to five internal parties to join a conference with only one request.

To initiate a Meet-Me-Conference:

- *Lift handset.
- *Press ICM key.
- *Dial page zone.
- *Instruct party/parties to meet you.
- *Press ADD ON key.

To join conference:

- *Lift handset.
- *Dial 8.

NOTE: Parties must join the conference within 30 seconds during which time the paged zone is held busy.

MEET-ME-ANSWER ON PAGING

4.23 Meet-Me-Answer On Paging is a programmable feature that enables a user to locate a specific person by paging and then establish a private handset to handset conversation.

To initiate a Meet-Me-Answer page:

- *Lift handset.
- *Press ICM key.
- *Dial desired zone.
- *Instruct party to meet you.
- *Press *.

To respond from any telephone in the zone:

- *Lift handset.
- *Dial 8.

NOTE: Party must respond within 30 seconds during which time the paged zone is held busy.

NON-PAGING STATIONS

4.24 Non-Paging Stations is a programmable feature for specified stations not to receive paging announcements. This feature is automatic when programmed.

CONFERENCE

4.25 Conference is a permanent feature which allows three-way conversations: two outside calls and one internal station, or one outside call and three internal stations. An alert tone can be heard as each party is added.

To add an outside call to a conference:

- *Place initial outside call.
- *Press ADD ON key.
- *Do NOT hang up.
- *Place second call on another CO line.
- *Press ADD ON key.

To add an internal party to a conference:

- *Place initial outside call.
- *Press ADD-ON key.
- *Press ICM key. Listen for dial tone.
- *Dial extension number and announce conference.
- *Press ADD-ON key when the called station joins the conference.

To join conference, called extension must:

- *Lift handset.
- *Press ICM key.

LAST NUMBER REDIAL

4.26 Last Number Redial is a permanent feature which automatically stores the last telephone number dialed. The number is stored whether the call was answered, not answered or busy.

To dial last number:

- *Lift handset.
- *Press idle CO Line or ICM key.
- *Press DC key.
- *Dial *.

SAVE LAST NUMBER

4.27 Save Last Number is an optional feature allowing the last number dialed to be saved and easily accessed when needed. The number remains in memory until it is replaced.

To save a number after dialing:

- *Press DC.
- *Dial #.

To dial the saved number:

- *Press DC.
- *Dial 0.

SPEED DIALING

4.28 Speed Dialing is a optional feature that permits automatic dialing of stored telephone numbers. There are two types of Speed Dialing: Station and System Speed Dialing.

Station Speed Dial

4.29 Each station programs individual speed dialing numbers A maximum of ten numbers, up to 16 digits each, can be stored.

To store a number:

- *Lift handset.
- *Press DC key.
- *Dial bin number (10-19).
- *Dial telephone number.
- *Hang up.
- *A stop can be inserted by dialing #.

To dial a stored number:

- *Lift handset.
- *Press idle Line key.
- *Press DC key.
- *Dial bin number (10-19).
- *If a stop is encountered, press * to restart dialng.

System Speed Dial

4.30 A maximum of 80 numbers, with up to 16 digits each, can be programmed into the system at a station assigned during system programming. These numbers are available to every station that is not restricted by programming.

To store System Speed Dial numbers at the assigned station:

- *Lift handset.
- *Press DC key.
- *Dial bin number (20-99).
- *Dial telephone number.
- *Hang up.
- *A stop can be inserted by dialing #.

To dial a System speed Dial number from any nonrestricted station:

- *Lift handset.
- *Press CO Line key.
- *Press DC.
- *Dial Bin number (20-99).
- *If a stop is encountered, press * to restart dialing.

QUEUING

4.31 Queuing is a programmable feature that enables a station to queue (wait in line) for an outside line when all lines in a Queue Group are busy. When a line in the group becomes available, the next station on queue receives ring tone and the line key flashes. The system automatically signals the stations in the order they joined the queue, when the line becomes available. If the line is not accessed within 20 seconds, then the line is made available to the next station in the queue. Queuing can be used to force outside calls to be made on specific lines (i.e. WATS, FX, etc.). If the next station in the queue is busy, then the line is offered to the following station. When the bypassed station becomes idle, the line is offered again.

NOTE: The Attendant station has priority on a queue. A line is offered to the Attendant station first.

To queue for an outside line:

- *Lift handset.
- *Press ICM key.
- *Press *.
- *Dial Queue Group number 1-4. Listen for dial tone to determine if request is accepted.
- *Hang up. When line becomes available telephone will ring.

+ICM Dial tone indicates station is queued; ICM busy tone indicates queue is full. Each queue group has eight positions and a station can join a queue only once.

To respond to queue signal:

- *Lift handset.
- *Press flashing CO line key.

CALLBACK

4.32 Callback is a permanent feature which allows the user to leave a callback request when an ICM call is placed to a busy station. When the called station is available, the system signals the party originating the callback request with an audible tone. If the originating party does not respond to the signal within 20 seconds, the callback is cancelled. When the originating party lifts the handset, the called station is signaled with an ICM ring tone and a flashing ICM key. A callback request will not be accepted if the called station is free, is in the DND mode, or has already accepted a callback request. Each station can accept only one callback request at a time.

To leave a Callback after placing a call and receiving a busy indication:

- *Press *.
- *Hang up.

NOTE: ICM dial tone is audible for 5 seconds if the request is accepted, no change in signal is heard when request is denied.

When the telephone rings:

- *Pick up handset.

To cancel a Callback request:

- *Lift handset.
- *Press *.
- *Dial previously called station.
- *Hang up handset.

MESSAGE WAITING

4.33 Message Waiting is a permanent feature which causes the HOLD key at a station to flash if the party has a message waiting at the DSS console.

To respond to message waiting indication:

- *Lift handset.
- *Press ICM key.
- *Dial "1".

HOTLINE

4.34 Hotline (HL) is an optional feature which provides a station with instant access to another station. Only two stations can have access to a specific hotline.

To call the other station assigned to the hotline:

- *Lift handset.
- *Press HL key.

The called party receives a unique audible signal which is five bursts of ICM ring tone.

To respond to a HL call:

- *Lift handset.
- *Press HL key.

DO NOT DISTURB

4.35 Do Not Disturb (DND) is a programmable feature which blocks all incoming audible signals for CO and ICM calls to a station. Callers attempting to reach a station that has invoked DND will receive reorder tone. Only the attendant or Hotline partner can override DND if DSS override is assigned. Only the Hotline partner or the attendant, if DSS override is assigned, can override the DND feature.

To initiate DND:

-*Press DND key.

To terminate DND:

-*Press DND key twice.†

†Pressing the key only once places station in the Microphone Mute mode.

EXECUTIVE CALL FORWARD

4.36 Executive Call Forward is a programmable feature that can be used in conjunction with the DND feature. Executive Call Forward sends certain calls made to a station in the DND mode to another designated station. The station in the DND mode (executive station) only receives Hotline calls. Private line calls, ICM calls and calls extended by the attendant are forwarded to the designated station (executive partner).

To activate Executive Call Forward:

-*Press DND key.

If a call is made to the executive's Private Line and the executive partner's corresponding CO line is busy, then a visual signal is given on that same line key at the partner's station.

BARGE-IN

CAUTION: Unauthorized monitoring of calls using the Barge-In feature may be interpreted as an invasion of privacy.

4.37 Barge-In is a programmable feature which permits any number of stations to be programmed to override the permanent Privacy feature. Only common CO line calls in progress are subject to Barge-In, without the normal alert tone.

To Barge-In on a line:

-*Lift handset.

-*Press CO Key for line to be entered.

PRIVATE LINE

4.38 Private Line is an optional feature requiring programming which reserves a CO line for exclusive use by a specific station. All incoming or outgoing calls are handled at the station programmed for the Private Line. Any Key Telephone can have one Private Line. Up to four Private Lines can be assigned in the system. A private line call can only be transferred using the Add-On key and only one station can join a conference with a private line.

To answer a call on the Private Line:

- *Lift handset.
- *Press CO Line key assigned as the Private Line.

To place a call on the Private Line:

- *Lift handset.
- *Press CO line key designated as Private Line.
- *Dial telephone number.

FLASH KEY

4.39 Flash Key is a programmable feature intended for PBX transfer, when pressed transfer dial tone is received.

To receive dial tone:

- *Press FL key.

BACKGROUND MUSIC

4.40 Background Music (BGM) is an optional feature which provides music through the loudspeakers in the system telephones. Music can also be provided through the paging system. The customer must provide the music source (i.e. radio, tuner, tape deck, piped-in-music, etc.).

To hear BGM:

- *Press # while telephone is idle.

To silence BGM:

- *Press #.

MUSIC-ON-HOLD

4.41 Music-On-Hold (MOH) is a permanent feature which provides internal synthesized music or optional music from the BGM source to lines placed on hold. This feature is automatic with system installation.

TOLL RESTRICTION

4.42 Toll Restriction is a programmable feature prohibiting selected stations from placing unauthorized toll calls. Stations can be restricted to internal calls, local calls or selected area codes depending on the class of service designated for that station.

"0" & "1" TOLL RESTRICTION

4.43 "0" & "1" Toll Restriction is a programmable feature which allows or disallows calls when the second digit dialed is a "0" or a "1". Some central office codes may have a "0" or "1" as the second digit making this restriction is undesirable.

RESTRICTED QUEUE GROUPS

4.44 Restricted Queue Groups is a programmable feature restricting stations from dialing on specified CO lines. Up to three queue groups can be assigned. This feature is automatic when programmed.

OFF PREMISE STATIONS

4.45 Off-Premise Stations (OPS) is an optional feature allowing single line telephones to be installed away from the Key Service Unit (KSU) location. For operation of OP equipment refer to section 9--OPTIONAL EQUIPMENT.

POWER FAILURE TRANSFER

4.46 Power Failure Transfer is an optional feature allowing up to five stations to make and/or receive calls during a local power failure. The type of telephone installed determines whether the telephone can be used to make or receive calls.

FLEXIBLE RINGING

4.47 Flexible Ringing is a programmable feature allowing up to 15 line ring groups to be established for use as day, night and common audible. The feature is automatic on key telephones when programmed.

OFF HOOK TONE SIGNALING

4.48 Off Hook Tone Signaling is a programmable feature that provides visual and audible signals of an incoming call to a user who is off-hook. This feature is automatic when programmed.

5. ATTENDANT FEATURES

5.01 The following paragraphs explain features that are unique to the Attendant station, in addition to previously mentioned features. The attendant station requires an ICM link.

DIRECT STATION SELECTION

5.02 The attendant console has DSS keys that provide the attendant with rapid intercom access to each station in the system.

To dial an intercom call using the DSS console:

- *Lift handset.
- *Press appropriate DSS key on console.
- *Announce call.

TRANSFER

5.03 Transfer is a permanent feature that enables the attendant to send an answered call to another station. The call is returned to the attendant if it is not answered after a programmed time period and the DSS console display indicates the line and the station number involved.

To transfer a call:

- *Press applicable DSS console key.

PAGING

5.04 The attendant can use the console to initiate pages.

To use All Call page:

- *Lift handset.
- *Press AC key on console.
- *Make announcement.
- *Hang up.

To use internal zone page:

- *Lift handset.
- *Press appropriate IZ key (1-4) on console.
- *Make announcement.
- *Hang up.

To use external paging:

- *Lift handset.
- *Press appropriate EZ key (1 or 2) on console.
- *Make announcement.
- *Hang up.

MESSAGE WAITING

5.05 Message Waiting (MW) is a system programmable feature that allows the attendant to leave a Message Waiting indication at a called station that is busy or does not answer. The indication is a flashing HOLD key.

To leave a message at a station:

- *Lift handset.
- *Press appropriate DSS console key.
- *Press MW key.

To cancel the message:

- *Press MW key.
- *Press appropriate DSS console key.

PBX CALL RINGING

5.06 PBX Call Ringing is a permanent feature that permits the DSS attendant to release a call and have it ring at the desired station. The signaled station rings and the CO line key flutters. The line can be answered at the signaled station in the normal manner. If, after a programmed transfer time, the call is not answered, it is returned to the attendant's station and the console display indicates the line and the station number involved. At this time the call can be picked up at any telephone. The SC key is used for PBX call ringing only.

To transfer an answered call using PBX Call Ringing:

- *Press appropriate DSS Console key.
- *Press SC key.
- *Hang up, or process another call.

ALARM REPEATING

5.07 Alarm Repeating is a programmable feature providing an audible alarm signal at the DSS console when a customer-provided security system is activated. When the system is in the Night Transfer (NT) mode the alarm will be sounded at all telephones. This feature is automatic at the Attendant's station if programmed.

CHAIN CALLING

5.08 Chain Calling is a permanent feature which allows the attendant to make a series of internal calls by pressing the DSS keys of the appropriate stations. No RLS key or hang up is necessary.

To make sequential ICM calls:

-*Press key of appropriate station.

DSS DISPLAY WITH FREEZE

5.09 The DSS console is equipped with a digital display which is used to indicate calls that may require attendant processing. The display rotates, in sequential order, unanswered lines that were transferred by the attendant and lines remaining on Exclusive Hold. When the attendant accesses a recalling line, the display freezes and shows the appropriate line and station number. Disconnecting from the recalling line restarts the display rotation.

DSS OVERRIDE

5.10 DSS Override is a programmable feature allowing the DSS attendant to override any station, including stations in the monitor or DND mode, to announce calls. This feature is automatic for the attendant station if programmed.

NIGHT TRANSFER

5.11 Night Transfer is a programmable feature allowing an alternate station to receive incoming CO audible and alarm signaling when the attendant station is unattended.

To transfer ring to alternate station:

-*Press NT key.

Table 2-1: VISUAL INDICATIONS ON TC-12/TC-22 KEY TELEPHONES

CO line Function	LED Indication
Incoming Call	60 IPM Flash
Regular Hold	120 IPM Wink
I-Hold	300 IPM Flutter
Exclusive Hold	120 IPM Flicker
Busy	Steady
Call Placed on Hold by DSS	120 IPM Flicker (DSS Telephone)
CO Line Call-Automatic Recall	300 IPM Flutter (DSS Telephone)
Intercom Function	LED Indication
Incoming ICM Call with Microphone ON	300 IPM Flutter
Incoming ICM call with Microphone OFF	60 IPM Flash
All ICM Lines Busy	Steady
Miscellaneous	LED Indication
Add-On	120 IPM Flicker
Do Not Disturb	Steady
Monitoring	Steady
Hotline Incoming Call	120 IPM Wink
Message Waiting (on HOLD Key)	60 IPM Flash

Table 2-2: AUDIBLE SIGNALS ON TC-12/TC-22 KEY TELEPHONES

C/O incoming audible signal	: 530/660/16Hz FM,	1 SEC On/3 SEC OFF
Auto-Recall	: 530/660/16Hz, FM,	1 SEC ON/3 SEC OFF
ICM tone signal call & RBT	: 425 Hz,	1 SEC ON/3 SEC OFF
Dial tone	: 425 Hz,	STEADY
Slow busy for ICM busy, Page busy, Off-Hook block and MON in use	: 425 Hz,	
Fast busy for DND	: 425 Hz,	120 IPM
Barge-In tone to party preempted	: 425/16 Hz AM,	60 IPM
Microphone On splash tone	: 800 Hz,	1 SPLASH
Microphone Off splash tone	: 800 Hz,	2 SPLASH
Hotline call	: 425 Hz,	5 SHORT SPLASH
Paging	: 425/16 Hz, AM,	1 SPLASH
Alarm	: 800 Hz,	300 IPM

TC-8 DS

ELECTRONIC KEY TELEPHONE SYSTEM

SECTION 3, SYSTEM CONFIGURATION

1. INTRODUCTION

1.01 The SYSTEM CONFIGURATION Section provides information to configure the equipment needs of a customer. The Option Configuration Worksheet (OCW) is used to gather specific system and station data for ordering equipment and completing the Program Record Form (PRF) in SECTION 4.

1.02 This paragraph is reserved for summarizing major revisions to this section.

2. DESCRIPTION OF COMPONENTS

2.01 The following paragraphs describe the component parts of a TC-8 DS system. This part is divided into groups: Key Service Unit (KSU), Power Supply Unit (PSU), Printed Circuit Boards (PCBs) and installation hardware.

Key Service Unit

2.02 The KSU houses the PCBs and is connected to the CO lines and station blocks.

Power Supply Unit

2.03 The PSU converts AC to DC current as required by the system.

Printed Circuit Boards

2.04 The following PCBs are required for system operation.

2.05 The Main Processor (A-MPU-B) PCB contains a Z80 microprocessor, system clocks, programs (ROM), program updating circuits and programming for Toll Restriction.

2.06 The Data Management (A-DMU) PCB contains two microcomputers for converting serial to parallel data or parallel to serial data between the stations and the Main Processor.

2.07 The Intercom Link (A-ILU) PCB contains voice-switching circuits for four handsfree talkpaths.

2.08 The Memory (A-NMU) PCB contains system Random Access Memory (RAM) and a fused battery circuit to protect memory during power failure. There are two versions of this PCB, one when Speed Dialing is incorporated and the other when it is not.

2.09 The Tone Sending (A-SSU) PCB contains Background Music (BGM) and Music-on-Hold (MOH) amplifiers, supervisory tone oscillators for internal system use and an alarm oscillator. There are two versions of this PCB, one in systems requiring DTMF signaling on CO lines, the other for dial pulse signaling.

2.10 The CO Line (A-LNU) PCB provides circuitry for common CO lines, private or hotlines and ring detection in the system. There are two versions, one containing 4-circuits, the other 2-circuits.

2.11 The Key Station Interface (A-SLU) PCB contains microcomputers and a switch matrix to connect to key stations. There are two versions of this PCB, one interfaces with four stations, the other with two.

2.12 The following PCBs are not required for system operation and are optional equipment.

2.13 The External Page Interface (A-EPU) PCB contains two 3-watt amplifiers for two external paging zones and provides auxiliary control relays for external amplifiers.

2.14 The Power Failure (A-PFU) PCB provides power failure transfer for five stations.

2.15 The Off-Premise Station (A-OPU) PCB enables up to four single line telephones to be installed away from the KSU location. Installation of this PCB is covered in section 9.

3. COLLECTION OF DATA

3.01 Two OCWs are provided in this section to help define the customer's needs. There is a System OCW (Table 3-1) and a Station OCW (Table 3-2). The customer, assisted by a sales or customer representative, should complete the worksheets. When completed, these worksheets will provide sufficient information to order the required hardware and to complete the Program Record Forms (PRFs) in Section 4.

System Options

3.02 Line 1a should indicate the number of lines to include all types of outside lines (i.e. common, wide area Telephone Service (WATS), Foreign Exchange (FX). Line 1b should indicate the number of private and/or Hotlines.

3.03 Line 2 should indicate the type of telephone service, tone or pulse. Most installers use tone signals. Pulse is also referred to as rotary since most pulse dials are the rotary type.

3.04 Line 3 should indicate if the system will be installed behind a Private Branch Exchange (PBX).

3.05 Line 4a should indicate the total number of stations to be installed. The Station OCW (Table 3-2) will assign various types of telephones to specific stations. Each DSS console counts as a separate station. Line 4b should indicate how many telephones are key telephones, line 4c how many single line telephones.

3.06 Line 5a should indicate if there will be paging in the system. Line 5b should indicate the type of paging. ALL CALL, Zone Paging and Meet-Me-Page are system features, but external paging requires optional equipment that must be purchased separately. Line 5c should indicate if optional equipment for paging is required.

3.07 Line 6 should indicate if Background Music (BGM) or Music on Hold (MOH) is desired. BGM requires an optional external music source that is purchased separately. Music On Hold (MOH) can use an optional external music source or internal synthesized music. The KSU has standard jacks for connecting the music source to the MOH and BGM Circuits. Background Music can be broadcast over the speakers in the key telephones. If the customer wants the music broadcast over a separate speaker system, then an optional external paging system must be purchased.

3.08 Line 7 should indicate if an alarm system, requiring optional equipment supplied by the customer, is desired.

3.09 Line 8a should indicate the number of queue groups (maximum 6). Line 8b should indicate how many lines in each group. Line 8c should indicate which groups should be restricted.

3.10 Lines 9, 10 and 11 should indicate if any permitted common unrestricted or PBX access codes are required.

3.11 Line 12 should indicate any absorb digits.

3.12 Line 13a should indicate if power failure operation is required. Line 13b should indicate how many power failure telephones will be required.

3.13 Line 14 should indicate the lowest and highest line for each line ring group. Use columns 4 and 5 of the Station OCW.

3.14 Line 15 should be checked if any of the mentioned features are desired.

Table 3-1: SYSTEM OPTION CONFIGURATION WORKSHEET

- 1a. How many outside lines are required in the system? _____.
(maximum 8)
- b. How many private and/or Hotlines are required in the system? (maximum 4) _____.
2. What type of service will be supplied by the operating telephone company? _____.
(most telco's have tone service)
3. Will the system be installed behind a PBX?
- 4a. How many stations are required? _____.
(maximum 20)
- b. How many stations will be key telephones? _____.
- c. How many stations will be single line telephones? _____.
(Each A-OPU PCB has four circuits and uses one station PCB slot in the KSU)
- 5a. Will there be paging in the system?
- b. If yes, then what type? _____.
- c. Will the systems be connected to an optional external paging system?
6. Will the system have Music-On-Hold?
Background Music?
7. Will the system have a customer supplied alarm system?
- 8a. How many Queue Groups will the system have? _____.
b. How many lines in each group? _____.
c. Which queue groups will be restricted? (max.3) _____.
- 9a. What permitted codes are required? (max. 8)
b. Maximum number of digits?
10. What common unrestricted codes are required?
11. What PBX access codes are required? (max.4)
12. What absorb digits are required? (max.4)
- 13a. Is power failure operation required?
b. How many power failure telephones will be installed?
(max. 5) _____.

14. What CO lines are in each Line Ring Group?

Group Number	Low Line	High Line
01	_____	_____
02	_____	_____
03	_____	_____
04	_____	_____
05	_____	_____
06	_____	_____
07	_____	_____
08	_____	_____
09	_____	_____
10	_____	_____
11	_____	_____
12	_____	_____
13	_____	_____
14	_____	_____
15	_____	_____

15. Will the following features be required?

- a. Meet-Me-Conference
- b. I-Hold Reminder
- c. Off-Hook Signaling
- d. DSS Override
- e. Recall Timing
- f. Flash Key & Location
- g. "0" or "1" as 2nd digit
- h. System Speed Dial, Station Number _____
- i. Station Speed Dial
- j. Last Number Save.

Station Options

3.15 The Station OCW (Table 3-2) is used to gather specific information about each station in the system. The following paragraphs provide detailed instructions on how to complete each part of the OCW for Station Options.

3.16 Column 1 should show the name of the person who will be using that station because it is often easier to associate feature requirements with a person rather than a station number.

3.17 Column 2 should show how many DSS keys are required at each station.

3.18 Column 3 should show the type of telephone to be installed at a particular station. Assure that all telephones in a group divided by bold lines are of the same type, either all key telephones or all single line telephones. The key telephones include: TC12, TC22, TC-22PF, and the DSS console. If the station is to be wall mounted, then put a check in the column labeled 'Wall Mounting'. The key telephones require a special wall mounting kit and the single line telephone is available in a wall mounted style.

3.19 Column 4 should show the numbers of lines (1-8) that will ring at each station during the day. Lines must be consecutively numbered.

3.20 Column 5 should show the lines (1-8) that should ring in each station when the system is in the Night Transfer (NT) mode. Lines must be consecutively numbered.

3.21 Column 6, BARGE-IN, should show which stations can interrupt other conversations in progress. Only Key Telephones can have this feature.

3.22 Column 7 should indicate which stations have DND feature.

3.23 Column 8 should indicate restricted queue groups.

3.24 Column 9 should indicate CLASS OF SERVICE (COS) dialing restrictions for the station. The following chart will outline the various COS:

0 & 1	No toll restrictions.
2	Can only dial permitted codes or common unrestricted codes.
3	Can only dial permitted codes, local 7-digit numbers, and common unrestricted codes.
4	Can dial permitted codes, 7-digit local numbers, 1+7 toll numbers and common unrestricted codes.
5	Can dial 7-digit local numbers, 1+7 toll numbers, and common unrestricted codes.
6	Can dial 7-digit local numbers, and common unrestricted codes.
7	Can dial only common unrestricted codes.
8	Can only dial ICM calls.

3.25 Column 10 should indicate four pairs of stations such that calls to one of the stations in a pair will automatically be forwarded to the other station in the same pair. If station is to have EXECUTIVE CALL FORWARD, enter the other station in the pair.

3.26 Column 11, should indicate whether or not the station will have a Private Line. A private line requires a CO line circuit in the KSU and must be counted in the total number of CO lines in the system.

3.27 Column 12 is for the HOTLINE feature. If a station is to have a HOTLINE, then the number for the HOTLINE partner must be entered.

3.28 Column 13 should show if a station is to receive paging announcements, enter which zone. Stations in each zone must be consecutively numbered with the lower station numbers in the First zone.

TABLE 3-2: STATION OPTION CONFIGURATION WORKSHEET

Station	1 Name	2 DSS Keys	TC12	TC22	3 TC22PF	Single Line	Wall Mount
20							
21							
22							
23							
24							
25							
26							
27							
28							
29							
30							
31							
32							
33							
34							
35							
36							
37							
38							
39							
4 Day Ring	5 Night Ring	6 Barge-In	7 DND	8 Queue Group	9 COS		
10 Exec Call- Forward	11 Private Line	12 Hotline	13 Paging				

4. ORDER REQUIREMENTS

4.01 The hardware for the TC-8 system can be ordered based on the information gathered on the OPTION CONFIGURATION WORKSHEETS (OCWs). Table 3-3 explains how the information on the OCW System is converted into order requirements. Table 3-4, TC-8 PCB CONFIGURATION determines how many of each PCB is needed.

TABLE 3-3 TC-8 ORDERING GUIDELINES

Complete this table using the OCWs (Table 3-1) just completed. Fill in the required number for each line.

1. TC-8 KSU (13018) and TC-12 Power Supply (13020)
2. Required PCBs
3. Optional PCBs
4. External Page required
5. External Music Source
6. One cable is required for connecting to telco RJ21X. (These cables are 25 pair, terminated with a 25 pair Plug on one end and connector on other end, and no longer than 25 feet.)
7. Number of cables for connecting KSU to connecting blocks. (These cables are 25 pair, terminated with 25 pair connector on one end.)
8. Number of Connecting Blocks for stations. (These blocks should be 25 pair split blocks with punchdown terminals.)
9. Two twisted pair station cable is used in standard telephony. The quantity required depends on the physical layout of the system.
10. Mounting hardware depends on the installation site, standard practices and National or local codes.

TABLE 3-4: TC-8 PCB CONFIGURATION

	PCB	MAXIMUM NUMBER IN SYSTEM		PART NUMBER	HOW MANY REQUIRED IN SYSTEM
A-MPU-B	Main Processor	1	1 req.	13267	
A-DMU-A	Data Management	1	1 req.	13270	
A-ILU-A	Intercom Link	1	1 req.	13281	
A-NMU-C	Memory without speed dialing	1	1 req.	13070	
A-NMU-D	Memory with speed dialing	1	1 req.	13095	
A-SSU-A	Tone Sending (DTMF)	1	1 req.	13055	
A-SSU-B	Tone Sending (Pulse)	1	1 req.	13061	
A-LNU-A	CO Line Four Circuit	3		13105	_____
A-LNU-B	CO Line Two Circuit	3		13115	_____
A-SLU-A	Key Station Four Station	5		13125	_____
A-SLU-B	Key Station Two Circuit	5		13135	_____
A-EPU-A	External Page	1	opt.	13181	_____
A-PFU-A	Power Failure	1	opt.	13190	_____
A-OPU-A	Off-Premise	1	opt.	13175	_____

TC-8 DS

ELECTRONIC KEY TELEPHONE SYSTEM

SECTION 4, PROGRAM RECORD FORM

1. INTRODUCTION

1.01 The PROGRAM RECORD FORM PREPARATION section provides directions for entering data onto the Program Record Form (PRF) at the end of this section. The PRF (Table 4-1) must be completed and retained as a job record.

1.02 This paragraph is reserved for summarizing major revision to this section.

2. DIRECTIONS

2.01 The following paragraphs provide directions for entering data onto the PRF and should be used with the completed Option Configuration Worksheets (Section 3).

2.02 Program 20, Line Ring Groups. CO lines can be organized into a maximum of 15 line ring groups for use as day, night and common audible signaling groups. Each line ring group consists of consecutively numbered lines. A line ring group can contain any number of common (non-private) lines; the lines in any individual group can overlap the lines in other groups.

Enter the lowest CO line number for each line ring group in the A/B boxes and the highest CO line number in the C/D boxes.

NOTES:

- (1) If only one line is to be assigned in the group, enter the line number in both the A/B and C/D boxes.
- (2) The line number entered cannot exceed the maximum number of common CO lines (08).

2.03 Program 21, Day Ring Group Stations. Stations can be assigned to ring according to the programmed line ring groups while the system is in the day signaling mode. Each station can be assigned to receive ringing from any one daytime line ring group.

Enter the line ring group number for each station in the C/D boxes.

NOTE: Station numbers 85 and 86 are used for External Paging Zones #1 and #2 respectively.

2.04 Program 22, System Speed Dial. Eighty 16-digit numbers can be accessed by all stations in the system. Only one station can be designated to enter system speed dial numbers.

Enter the station number permitted to enter numbers into the "system based" speed dial memory in the C/D boxes.

NOTE: To use Program 22, the system must be equipped with an A-NMU-D PCB.

2.05 Program 23, Meet-Me-Conference. Up to five stations can join an internal conference after an internal page.

Enter "1" if feature is desired, "0" if not desired in the D box.

2.06 Program 24, Barge-In. Individual stations can override the CO line privacy feature. All stations can be programmed to use this feature; however, only three stations can be connected to one CO line at one time.

Enter "1" for each station allowed to override CO line privacy, "0" for all other stations in the D box.

2.07 Program 25, I-Hold Reminder. An audible signal can be provided as a reminder that a call has been left on hold. Two times must be programmed.

Enter the amount of time between each reminder signal from the times given below in the first C/D boxes.

00	=	no reminder
01	=	10 seconds
02	=	20 seconds
03	=	30 seconds
04	=	40 seconds
05	=	50 seconds
06	=	60 seconds
07	=	70 seconds
08	=	80 seconds
09	=	90 seconds
10	=	100 seconds

Enter the duration of reminder signal from times below in the second C/D boxes.

00	=	Continuous
01	=	10 seconds
02	=	20 seconds
03	=	30 seconds
04	=	40 seconds
05	=	50 seconds
06	=	60 seconds
07	=	70 seconds

08 = 80 seconds
09 = 90 seconds
10 = 100 seconds

Programs 26, 27 & 28 are not used

2.08 Program 29, Off-Hook Signaling & DSS Override. Off-Hook Signaling provides CO and ICM tone signals for all stations when the telephone is either on-hook or off-hook. If the system is not programmed for off-hook signaling, stations will only receive CO or ICM audible when on-hook. DSS Override allows the DSS attendant to override the Do-Not-Disturb (DND) feature or the monitor to announce calls.

Enter "0" if neither off-hook signaling nor DSS Override is required, "1" if only off-hook signaling is required, "2" if only DSS Override is required, and "3" if both off-hook signaling and DSS Override are required in D box.

2.09 Program 30, DTMF Off-Premise Station. If the system is equipped with off-premise stations using tone signaling, this must be programmed for proper operation.

Enter "1" for each DTMF OP station, "0" for all other stations in the D box.

Note: An A-OPU-B PCB equipped with MFRB-A PCBs is required.

2.10 Program 31, Do-Not-Disturb. Stations can block all incoming calls including ICM call-back. However, the DSS attendant can override if the DSS override feature is programmed. HL calls will not be blocked.

Enter "1" for stations with DND, "0" for all other stations in the D box.

2.11 Program 32, Recall Timing. An audible signal can be provided as a recall for calls placed on exclusive hold. Two times must be programmed.

Enter amount of time a call is left on exclusive hold before a recall signal is given from times below in the first C/D boxes.

00 = no recall time
01 = 10 seconds
02 = 20 seconds
03 = 30 seconds
04 = 40 seconds
05 = 50 seconds
06 = 60 seconds
07 = 70 seconds
08 = 80 seconds
09 = 90 seconds
10 = 100 seconds

NOTE: This time also defines the time before a recall signal is given when a call is transferred using a DSS key.

Enter the duration of recall signal in the C/D boxes.

00 = no recall signal
01 = 10 seconds
02 = 20 seconds
03 = 30 seconds
04 = 40 seconds
05 = 50 seconds
06 = 60 seconds
07 = 70 seconds
08 = 80 seconds
09 = 90 seconds
10 = 100 seconds

NOTE: This time also defines the time before a recall is given when the DSS attendant uses PBX Call Ringing.

2.12 Program 33, CO Line Signaling. CO lines can be programmed as either DTMF or dial pulse signaling.

Enter "1" for dial pulse signaling, "0" for DTMF signaling in the D box.

2.13 Program 34, PBX Lines. Lines can be assigned for PBX operation. Lines which are connected to a PBX must be assigned as PBX lines for proper operation of the Toll Restriction and Flash Key programs.

NOTE: When PBX lines are programmed, the PBX access codes must be entered in Program 44.

Enter "1" to assign lines for PBX operation, "0" for normal CO line operation in the D box.

2.14 Program 35, Flash Key. If a Flash Key is required, the flash time interval must be assigned. When a line is connected to a PBX, an open-loop flash of the duration programmed will occur when the flash key is pressed.

NOTE: PBX lines must be assigned in Program 34 to obtain the following flash intervals. Flash intervals for non-PBX lines will be 3 seconds regardless of the entry, except 00. A 00 entry will result in NO Flash key operation for all lines.

Enter the flash interval from times below in the C/D boxes.

00 = no flash
01 = 100 msec flash
02 = 200 msec flash
03 = 300 msec flash
04 = 400 msec flash
05 = 500 msec flash
06 = 600 msec flash
07 = 700 msec flash
08 = 800 msec flash
09 = 900 msec flash
10 = 1 second flash (msec.=milliseconds)

2.15 Program 36, Meet-Me-Page. A handset to handset call can be established with a paging party.

Enter "1" if the feature is desired, "0" if not desired in the D box.

2.16 Program 37, Queue Group Restrictions. Stations which are restricted in Program 38 will not be allowed to access an outgoing line within an assigned queue group (Figure 4-1). Up to three queue groups can be assigned.

NOTE: By default, Station Class of Service will be invoked on lines in all queue groups not assigned in Program 37.

Enter Queue Group number (1-4) to be restricted in the D box.

2.17 Program 38, Outgoing Station Restrictions. Stations can be allowed or denied outgoing access to lines in queue groups assigned in Program 37.

Enter "1" to deny access for each station, "0" for all other stations in the D box.

2.18 Program 39, Station Class of Service. On the basis of a station's class of service, toll restrictions will be applied when calling out on a line in a queue group not assigned in Program 37.

Enter the Class of Service for each station from chart below in the D box.

0 & 1	No toll restrictions.
2	Can only dial permitted codes or common unrestricted codes.
3	Can only dial permitted codes, local 7-digit numbers, and common unrestricted codes.
4	Can dial permitted codes, 7-digit local numbers, 1+7 toll numbers and common unrestricted codes.
5	Can dial 7-digit local numbers, 1+7 toll numbers, and common unrestricted codes.
6	Can dial 7-digit local numbers, and common unrestricted codes.
7	Can dial only common unrestricted codes.
8	Can only dial ICM calls.

NOTES:

- (1) Toll restriction will not be effective on CO lines assigned in Program 37.
- (2) There is no toll restriction on private lines, except class 8 service.
- (3) Behind a PBX, any toll restriction will be applied after the PBX access code digits have been dialed.
- (4) Only classes 0 & 1 station users can dial 0 or 1 as the 1st or 2nd digit except for permitted codes.

- (5) Program 43 can be used to override the second digit restriction.

2.19 Program 40, Queue Groups. CO lines are assigned to queue groups.

Enter for each line the code from the chart below in the D box.

Code	Function
0	No queuing or Off-Premise Extension (OPX) access will be allowed for any line assigned to this group. This code should be entered for unused lines. These lines cannot be extended to an Off-Premise (OP) station by the attendant using the SC key on the console. This group cannot be assigned in Program 37.
1	Queue group #1
2	Queue group #2
3	Queue group #3
4	Queue group #4
5	No queuing or OPX dial access will be allowed on a line assigned to this group. This code should be entered for private and hotlines. This group cannot be assigned in Program 37.

NOTES:

- (1) In the initialization program, the code 0 is entered for all lines. All unused line positions must be programmed with a "0". Lines removed from service must be reprogrammed if previously programmed with any other code.
- (2) One queue group (usually group #1) should be used for local lines. The other groups could be used for FX lines, WATS lines in different WATS bands, tie lines, etc.

2.20 Program 41, Permitted Codes. Establish up to eight 8-digit codes to be dialed by stations having service classes 2, 3 or 4. Permitted codes allow users to make calls to: a division of their business in a specific exchange and area code, nearby areas having different area codes where business is normally conducted and "in-WATS" (800) services.

NOTES:

- (1) If less than 8-digits are entered as a permitted code than any digit entered after the last digit will be allowed (up to the maximum number of digits allowed by Program 42). For example, 1-800 is a permitted code, any digits dialed after 1-800 will be allowed.
- (2) The DC key is used to program a digit as a "don't care" digit. For example: 1-DC-DC-DC-5-5-5 allows users to reach the information operator in any area code.
- (3) Do not enter 0 or DC as the first digit of a permitted code, as this will allow the user to access a toll operator.
- (4) Use Program 42 to enter the maximum number of digits that will be permitted.

Enter each digit of each permitted code in the D boxes.

2.21 Program 42, Permitted Code Digits. A maximum number of digits can be specified for a permitted code.

NOTES:

- (1) If 0 is entered, any number of digits are permitted to be dialed.
- (2) Do not enter DC.

Enter maximum number of digits which will be permitted in the C/D boxes.

2.22 Program 43, "0" or "1" in 2nd digit. The "0" or "1" in 2nd Digit restriction is used to prevent long distance toll calling. In areas such as New York and Los Angeles, local central office codes may have a 0 or 1 as a second digit. In such cases, restriction is not desirable.

NOTE: This program will only apply to station classes 3, 4, 5 or 6.

Enter "1" to allow dialing "0" or "1" as the 2nd digit, "0" to deny in the D box.

2.23 Program 44, PBX Access Codes. In order to obtain proper class of service, access codes are entered allowing users to access CO lines when the system is installed behind a PBX.

2.24 If the PBX provides night transfer or call pickup using dial access codes, these codes should be programmed as CO line access codes to prevent defeating toll restriction.

NOTES:

- (1) A maximum of 4 access codes can be entered.
- (2) Access codes consist of 1 or 2 digits.
- (3) DC can be entered as the second digit only.

Enter access codes in the D boxes.

2.25 Program 45, Common Unrestricted Codes. Up to four 4-digit common unrestricted codes can be established for stations with classes of service 2 through 7. Examples of these codes are; emergency-assistance (911), local directory (411 or 1411) and telephone repair (611).

NOTE: Do not enter 0 or DC as the first digit as this will allow the user to access a toll operator.

Enter each digit of each code in the D boxes.

2.26 Program 46, Digit Absorbing. In certain central offices, specific digits (when dialed as the first digit) are absorbed (ignored).

NOTES:

- (1) Up to four absorb digits can be entered.
- (2) Do not enter 0 or 1 as an absorb digit, as this will allow the user to access a toll operator.
- (3) A check should be made to verify that the first digit has been absorbed:
 - *Dial the first digit of a local exchange.
 - *Dial 0; if the call is routed to an operator, the first digit was probably absorbed.
 - *Repeat procedure two or three times for verification.
 - *Dial the absorbed digit twice.
 - *Dial Operator; if the digit has been absorbed, the operator should be reached.

Enter the absorb digits in the D boxes.

2.27 Program 47-50, Executive Call Forward. Four pairs of stations can be arranged so that calls to one of the stations in a pair will automatically be forwarded to the other station in the same pair. Calls which will be forwarded include ICM calls, CO calls extended by the attendant, and calls coming in on the private line.

NOTES:

- (1) The executive station must be programmed for DND.
- (2) The other station in the pair cannot be assigned a private line.
- (3) A station can be assigned to only one pair.

Enter executive's station number in the A/B boxes, and the other station's number in the C/D boxes.

2.28 Programs 51-54, Private Line/Hotline Assignments. A station can have up to 1 private line and 1 hotline assigned. Up to four private and/or hotlines can be assigned. The line circuits are assigned as follows:
Program 51 assigns Private line/Hotline #4 on line circuit 9,
Program 52 assigns Private line/Hotline #3 on line circuit 10,
Program 53 assigns Private line/Hotline #2 on line circuit 11,
Program 54 assigns Private line/Hotline #1 on line circuit 12.

For programming Hotlines:

Enter the station number of the first station of hotline pair in the A/B boxes and the number of the other station in the C/D boxes.

For programming Private Lines:

Enter 00 in the A/B boxes and the station number in the C/D boxes.

2.29 Program 55, Flash Key Location. The flash key can appear on the telephone as either line key 12 or line key 22. The location affects the hotline and private line key locations. These keys will always appear just preceding the flash key.

Enter "1" to use line key 22, "0" in the D box to use line key 12 as the Flash key.

2.30 Program ALM, Alarm. Alarm signals from a customer-provided security system can be transmitted to telephones in the system.

Enter "1" in the D box if alarm detection is for an "open" circuit (normally closed contacts) and "0" if no alarm detection is required or if alarm detection is for a "closed" circuit indication (normally open contacts).

2.31 Programs EZ1-EZ2, External Paging Zones. The system can be equipped with two external paging zones and can be programmed to supply Background Music (BGM) to the external paging zones.

Enter "1" in the D box if BGM is required, "0" if not required for each external zone.

2.32 Programs IZ1-IZ4, Internal Paging Zones. Stations can be assigned to internal paging zones.

NOTES:

- (1) Stations in an internal paging zone must be consecutively numbered.
- (2) The lowest stations must be entered in the first internal paging zone, e.g. IZ1 then IZ2 etc.
- (3) A station can be assigned to only one zone.
- (4) Stations not assigned to an internal paging zone will not receive any paging announcements.

Enter lowest station number for each zone in the A/B boxes and the highest station number for each zone in the C/D boxes.

NOTE: If only one station is to be assigned to an internal paging zone, enter that station number in both the A/B and C/D boxes.

2.33 Program NT, Night Transfer. Stations can receive ringing from programmed line ring groups while the system is in the night transfer mode.

NOTES:

- (1) Stations will receive incoming night ring only from the assigned line ring group.
- (2) Station numbers 85 and 86 are used for external paging zones #1 and #2 respectively.

Enter line ring group number for each station to receive night audible signals in the C/D boxes.

PROGRAM 38

STATION DIAL RESTRICTION

PROGRAM 37

QUEUE
GROUP
RESTRICTIONS

PROGRAM 39

STATION CLASS OF SERVICE

PROGRAM 40

0
1
2
3
4
5

Figure 4-1 QUEUE GROUP RESTRICTION

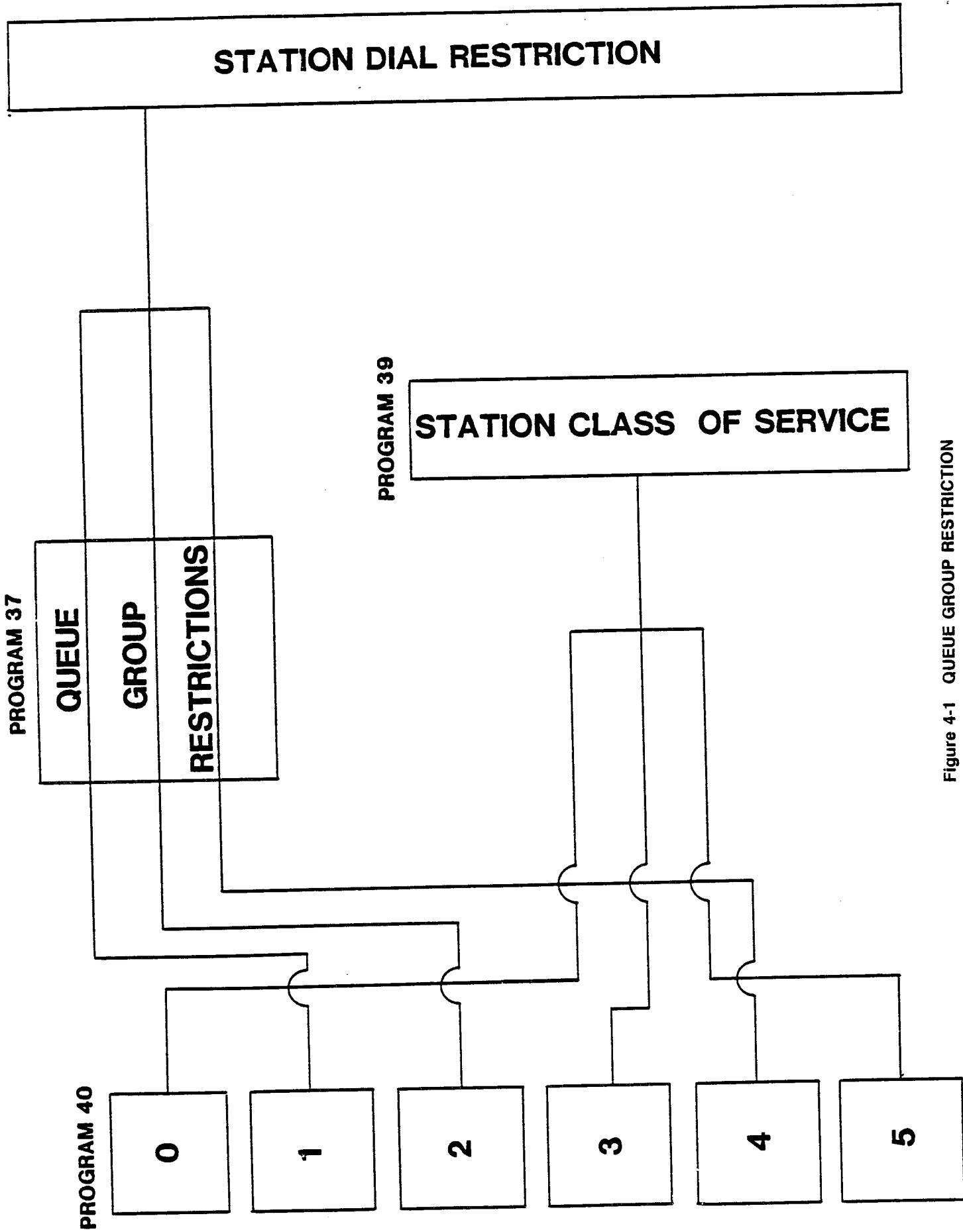

3. TOLL RESTRICTION

Toll Restriction Compatibility With PBX

3.01 While engineering efforts have been made to make the toll restriction program compatible with the majority of PBXs, before installing this feature in systems behind a PBX, make sure that PBX signaling arrangements (particularly the transfer function) and the toll restriction arrangements of this system are compatible with the PBX.

WARNING: CHECK COMPATIBILITY WITH THE PBX.

3.02 Electronic key telephone systems are able to recognize trunk access codes. The toll restriction program is not started until such a code is recognized. Using Program 44, up to 4 different 1 or 2-digit codes can be programmed as trunk access codes.

3.03 Stations assigned to Classes of Service 0 through 7 are permitted to dial any PBX number, even those containing 0's and 1's, without encountering restriction.

3.04 Class of Service 8 is intended for use in systems behind a PBX where the user is not permitted to dial on PBX lines, but may dial all intercom calls.

Incoming Vs Outgoing PBX Calls

3.05 The system has the ability to recognize the difference between an incoming call and an outgoing call. Only stations with class of service 0 are permitted dialing on incoming calls. Stations with class of service 1 are permitted dialing on incoming calls for lines not in a restricted queue group (Program 37). The system has no way of determining whether the call is from another PBX station or from an outside line. If dialing were permitted under this condition, toll restriction could be defeated.

PBX Flashing

3.06 In many PBX systems, the flash key is used for transferring incoming calls. The TC-8 system is designed to function with PBX systems having transfer operation.

CAUTION: If the PBX does NOT require flashing for transfer, do not program the system for flash key operation.

3.07 The effect of flash key operation on the toll restriction program will vary, depending on the station class of service (Program 39) and whether the station is involved in an outgoing or an incoming call, as follows:

- a. Outgoing Call. Operation of the flash key transmits an open pulse to the PBX trunk circuit for transfer and, at the same time, activates the toll restriction program.
- b. Incoming Call. On an incoming call, dialing is blocked until the flash key is operated except for classes 0 and 1, where dialing can be allowed. The first operation of the flash key (and subsequent odd numbered flashes) will permit dialing into the PBX. The second operation of the flash key (and subsequent even numbered flashes) will again restrict dialing.

Dial And Class Arrangements for PBX Operation

3.08 Most PBX systems today utilize toll restriction programs that are more comprehensive than those used in key systems (primarily for economical reasons). The toll restriction programs utilize the fact that the system "knows" which stations are using which lines and can operate on the restriction parameters programmed into the system. When the stations are separated from the PBX by a key system (which is really a concentrator), the association between station and line is no longer available to the PBX. Thus, the key system must provide more flexible restriction arrangements.

3.09 Recommendation: The following method can be used to provide the flexibility required:

- a. Program the PBX non-restricted lines so that outgoing station restrictions (Program 38) apply i.e. assign these lines in Program 37, and program outgoing station restrictions as required.
- b. Assign all stations that are to be subject to PBX toll restriction to Class of Service 0 or 1.
- c. Assign stations permitted to make only PBX calls to Class of Service 7 and make sure that the trunk access codes are written in Program 44.
- d. Assign stations permitted to make only key system calls to Class of Service 8.
- e. Assign stations that are to be assigned key system toll restrictions to the appropriate class of service: 2 through 6.

Table 4-1 TC-8 DS PROGRAM RECORD FORM

Program 20
Line Ring Groups

	A	B	C	D
01	—	—	—	—
02	—	—	—	—
03	—	—	—	—
04	—	—	—	—
05	—	—	—	—
06	—	—	—	—
07	—	—	—	—
08	—	—	—	—
09	—	—	—	—
10	—	—	—	—
11	—	—	—	—
12	—	—	—	—
13	—	—	—	—
14	—	—	—	—
15	—	—	—	—

Program 21
Day Ring Group
Stations

	A	B	C	D
2 0	—	—	—	—
2 1	—	—	—	—
2 2	—	—	—	—
2 3	—	—	—	—
2 4	—	—	—	—
2 5	—	—	—	—
2 6	—	—	—	—
2 7	—	—	—	—
2 8	—	—	—	—
2 9	—	—	—	—
3 0	—	—	—	—
3 1	—	—	—	—
3 2	—	—	—	—
3 3	—	—	—	—
3 4	—	—	—	—
3 5	—	—	—	—
3 6	—	—	—	—
3 7	—	—	—	—
3 8	—	—	—	—
3 9	—	—	—	—
8 5	—	—	—	—
8 6	—	—	—	—

Program 22
System Speed Dial

	A	B	C	D
0 0	—	—	—	—

Program 23
Meet-Me-Conference

	A	B	C	D
0 0 0	—	—	—	—

Program 24
Barge-In

	A	B	C	D
2 0 0	—	—	—	—
2 1 0	—	—	—	—
2 2 0	—	—	—	—
2 3 0	—	—	—	—
2 4 0	—	—	—	—
2 5 0	—	—	—	—
2 6 0	—	—	—	—
2 7 0	—	—	—	—
2 8 0	—	—	—	—
2 9 0	—	—	—	—
3 0 0	—	—	—	—
3 1 0	—	—	—	—
3 2 0	—	—	—	—
3 3 0	—	—	—	—
3 4 0	—	—	—	—
3 5 0	—	—	—	—
3 6 0	—	—	—	—
3 7 0	—	—	—	—
3 8 0	—	—	—	—
3 9 0	—	—	—	—

Program 25
I-Hold Reminder

	A	B	C	D
0 1	—	—	—	—
0 2	—	—	—	—

Program 26-28
Not used

Program 29
Off-Hook Signaling
DSS Override

	A	B	C	D
0 0 0	—	—	—	—

Program 30
DTMF Off-Premise
Station

	A	B	C	D
2 0 0	—	—	—	—
2 1 0	—	—	—	—
2 2 0	—	—	—	—
2 3 0	—	—	—	—
2 4 0	—	—	—	—
2 5 0	—	—	—	—
2 6 0	—	—	—	—
2 7 0	—	—	—	—
2 8 0	—	—	—	—
2 9 0	—	—	—	—
3 0 0	—	—	—	—
3 1 0	—	—	—	—
3 2 0	—	—	—	—
3 3 0	—	—	—	—
3 4 0	—	—	—	—
3 5 0	—	—	—	—
3 6 0	—	—	—	—
3 7 0	—	—	—	—
3 8 0	—	—	—	—
3 9 0	—	—	—	—

Program 31
Do-Not-Disturb

	A	B	C	D
2 0 0	—	—	—	—
2 1 0	—	—	—	—
2 2 0	—	—	—	—
2 3 0	—	—	—	—
2 4 0	—	—	—	—
2 5 0	—	—	—	—
2 6 0	—	—	—	—
2 7 0	—	—	—	—
2 8 0	—	—	—	—
2 9 0	—	—	—	—
3 0 0	—	—	—	—
3 1 0	—	—	—	—
3 2 0	—	—	—	—
3 3 0	—	—	—	—
3 4 0	—	—	—	—
3 5 0	—	—	—	—
3 6 0	—	—	—	—
3 7 0	—	—	—	—
3 8 0	—	—	—	—
3 9 0	—	—	—	—

Program 32
Recall Timing

	A	B	C	D
0 1	—	—	—	—
0 2	—	—	—	—

Program 33
CO Line Signaling

	A	B	C	D
0 0 0	—	—	—	—

Program 34
PBX Lines

	A	B	C	D
0 1 0	—	—	—	—
0 2 0	—	—	—	—
0 3 0	—	—	—	—
0 4 0	—	—	—	—
0 5 0	—	—	—	—
0 6 0	—	—	—	—
0 7 0	—	—	—	—
0 8 0	—	—	—	—
0 9 0	—	—	—	—
1 0 0	—	—	—	—
1 1 0	—	—	—	—
1 2 0	—	—	—	—

Program 35
Flash Key

	A	B	C	D
0 0	—	—	—	—

Program 36
Meet-Me-Page

	A	B	C	D
0 0 0	—	—	—	—

Program 37
Queue Group
Restrictions

	A	B	C	D
0 1 0	—	—	—	—
0 2 0	—	—	—	—
0 3 0	—	—	—	—

Program 38
Outgoing Station
Restrictions

A	B	C	D
2	0	0	---
2	1	0	---
2	2	0	---
2	3	0	---
2	4	0	---
2	5	0	---
2	6	0	---
2	7	0	---
2	8	0	---
2	9	0	---
3	0	0	---
3	1	0	---
3	2	0	---
3	3	0	---
3	4	0	---
3	5	0	---
3	6	0	---
3	7	0	---
3	8	0	---
3	9	0	---

Program 40
Queue Groups

A	B	C	D
0	1	0	---
0	2	0	---
0	3	0	---
0	4	0	---
0	5	0	---
0	6	0	---
0	7	0	---
0	8	0	---
0	9	0	---
1	0	0	---
1	1	0	---
1	2	0	---

Program 45
Common Unrestricted Codes

A	B	C	D	A	B	C	D	A	B	C	D	A	B	C	D
0	1	X	---	0	1	X	---	0	1	X	---	0	1	X	---
0	2	X	---	0	2	X	---	0	2	X	---	0	2	X	---
0	3	X	---	0	3	X	---	0	3	X	---	0	3	X	---
0	4	X	---	0	4	X	---	0	4	X	---	0	4	X	---

Program 46
Digit Absorbing

A	B	C	D
0	1	X	---
0	2	X	---
0	3	X	---
0	4	X	---

Program 41
Permitted Codes

A	B	C	D	A	B	C	D	A	B	C	D	A	B	C	D	A	B	C	D	A	B	C	D
0	1	X	---	X	---	X	---	X	---	X	---	X	---	X	---	X	---	X	---	X	---	X	---
0	2	X	---	X	---	X	---	X	---	X	---	X	---	X	---	X	---	X	---	X	---	X	---
0	3	X	---	X	---	X	---	X	---	X	---	X	---	X	---	X	---	X	---	X	---	X	---
0	4	X	---	X	---	X	---	X	---	X	---	X	---	X	---	X	---	X	---	X	---	X	---
0	5	X	---	X	---	X	---	X	---	X	---	X	---	X	---	X	---	X	---	X	---	X	---
0	6	X	---	X	---	X	---	X	---	X	---	X	---	X	---	X	---	X	---	X	---	X	---
0	7	X	---	X	---	X	---	X	---	X	---	X	---	X	---	X	---	X	---	X	---	X	---
0	8	X	---	X	---	X	---	X	---	X	---	X	---	X	---	X	---	X	---	X	---	X	---

Program 39
Class of Service

A	B	C	D
2	0	0	---
2	1	0	---
2	2	0	---
2	3	0	---
2	4	0	---
2	5	0	---
2	6	0	---
2	7	0	---
2	8	0	---
2	9	0	---
3	0	0	---
3	1	0	---
3	2	0	---
3	3	0	---
3	4	0	---
3	5	0	---
3	6	0	---
3	7	0	---
3	8	0	---
3	9	0	---

Program 42
Permitted Code
Digits

A	B	C	D
0	0	---	---

Program 43
"0" or "1"

A	B	C	D
0	0	0	---

Program 44
PBX Access Codes

A	B	C	D
0	1	X	---
0	2	X	---
0	1	X	---
0	2	X	---
0	1	X	---
0	2	X	---
0	1	X	---
0	2	X	---

Program 47
Executive Call Forward

A	B	C	D
---	---	---	---

Program 48
Executive Call Forward

A	B	C	D
---	---	---	---

Program 49
Executive Call Forward

A	B	C	D
---	---	---	---

Program 50
Executive Call Forward

A	B	C	D
---	---	---	---

Program 51
Private/Hotline

A B C D
— — — —

Program 52
Private/Hotline

A B C D
— — — —

Program 53
Private/Hotline

A B C D
— — — —

Program 54
Private/Hotline

A B C D
— — — —

Program 55
Flash Key

A B C D
0 0 0 —

Program ALM
Alarm

A B C D
0 0 0 —

Program EZ1
External Paging

A B C D
0 0 0 —

Program EZ2
External Paging

A B C D
0 0 0 —

Program IZ1
Internal Paging

A B C D
— — — —

Program IZ2
Internal Paging

A B C D
— — — —

Program IZ3
Internal
Paging

A B C D
— — — —

Program IZ4
Internal
Paging

A B C D
— — — —

Program NT
Night Transfer

A	B	C	D
2	0	—	—
2	1	—	—
2	2	—	—
2	3	—	—
2	4	—	—
2	5	—	—
2	6	—	—
2	7	—	—
2	8	—	—
2	9	—	—
3	0	—	—
3	1	—	—
3	2	—	—
3	3	—	—
3	4	—	—
3	5	—	—
3	6	—	—
3	7	—	—
3	8	—	—
3	9	—	—
8	5	—	—
8	6	—	—

TC-8 DS

ELECTRONIC KEY TELEPHONE SYSTEM

SECTION 5, INSTALLATION

1. INTRODUCTION

1.01 The INSTALLATION Section provides detailed procedures for installing a TC-8 DS system. Read and understand this entire section before proceeding.

1.02 This paragraph is reserved for summarizing major revisions to this section.

2. PREPARATION

2.01 Before proceeding with installation consider the following factors:

Site Requirements

2.02 The area for mounting the KSU and related control equipment should be clean, dry, temperature controlled and accessible only to authorized personnel. The site should be away from caustic chemicals, heavy machinery, static electricity and copying machines. There should be ample room to mount and maintain the equipment (Figure 5-1).

2.03 There must be a dedicated three wire 115VAC 15AMP circuit for the power supply. The outlet must be three prong and within 6 feet (2m) of the power supply location.

2.04 An earth ground must be provided, using 14 AWG or larger insulated wire.

2.05 Telco lines, terminated in an RJ21X USOC connector, must be within 25 feet (7m) of the KSU location.

SITE SUMMARY CHECK

- *Location acceptable
- *KSU installation layout
- *AC line(s) installed
- *Provisions for ground
- *Telco lines available

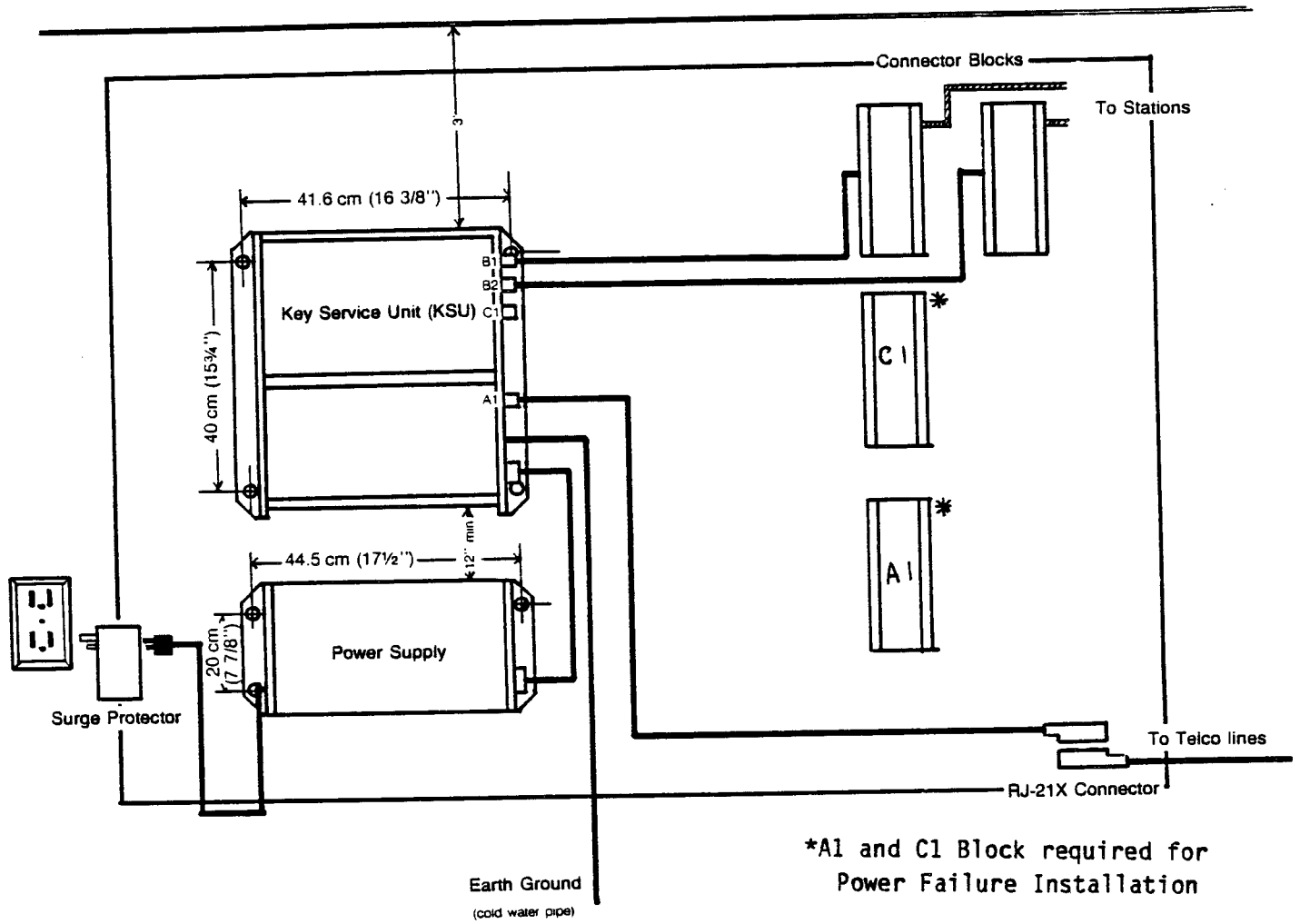

Figure 5-1 KSU MOUNTING SITE

Tools and Test Equipment

2.06 In addition to the test equipment and tools used for a typical installation, the following items will be needed:

- (a) Volt Meter.
- (b) DSS Console for programming.

Equipment Requirements

2.07 Unpack the telephone equipment and compare the equipment received to a list of equipment ordered to insure that all components are on site. Check for any physical damage. Verify the number and types of station instruments for the installation.

2.08 A maximum of 5 power failure CO lines can be installed. The following materials are needed for power failure connections:

- (a) 66M1-50 type connecting block equipped with 1 male (blue) and 1 female (red) connector.
- (b) 89-type mounting bracket(s).
- (c) 66MC connecting block cover(s).
- (d) One 25-pair-cable, connector ended, male (blue)/female (red), the length as required.

2.09 Have the necessary hardware and cables available. This includes: exterior grade plywood backboard, 25-pair cables for telco connection, two twisted pair station cable, grounding wire (14 AWG), connecting blocks (66M1-50 type) with bridging clips, modular station jacks (625A4, 625F4, or equivalent), power line surge protector and appropriate mounting hardware.

2.10 Before starting the installation, verify that the following documents are complete and on the premise:

- (a) Building plan with stations marked for location and type of telephone instrument.
- (b) Option Configuration Work Sheets (Tables 3-1 and 3-2).
- (c) Program Record Form (Table 4-1).

EQUIPMENT SUMMARY CHECK

- *Equipment present
- *Hardware present
- *Necessary documents on site

3. INSTALLATION

3.01 The installation procedures are divided into four parts: KSU and Power Supply Installation, Installing PCBs, Station Cabling and System Connections and Station Installation. Key stations must be installed after all other installation steps are completed.

3.02 Alterations or modifications of equipment not expressly shown in this installation manual are prohibited. If equipment malfunction is suspected, then disconnect your system from the telephone company lines by unplugging the telco RJ21X connector.

4. KSU AND POWER SUPPLY INSTALLATION

4.01 Attach the plywood in the designated location with appropriate fasteners. Mark the equipment layout on the backboard.

4.02 A surge protector should be installed at the dedicated AC receptacle. The recommended protector is a TII Model 428 Plug-In Power Line Surge Protector, or equivalent. Connect this unit according to manufacturer's instructions.

BACKBOARD INSTALLATION CHECK

- *Mount backboard and mark equipment layout
- *Install surge protector

4.03 To mount the KSU:

- *Mark four points on the backboard that correspond to the dimensions between the mounting hole centers (Figure 5-2).
- *Drill pilot holes at these points and insert suitable fasteners having a 1/4 inch shank diameter. Screw in fasteners until the clearance between the fastener head and the mounting surface is 1/4 inch.
- *Mount KSU on the four fasteners and tighten each fastener until the KSU is securely attached to the mounting surface.

NOTE: Do not install PCBs at this point.

4.04 To mount the power supply:

NOTE: Mount the power supply at least 12 inches below the KSU and within 6 feet of the AC outlet.

- *Mark four points on the backboard that correspond to the dimensions between the mounting hole centers (Figure 5-3).
- *Drill pilot holes at these points and insert suitable fasteners having a 1/4 inch shank diameter. Screw in fasteners until the clearance between the fastener head and the mounting surface is 1/4 inch.
- *Mount power supply on the four fasteners and tighten each fastener until the power supply is securely attached to the mounting surface.

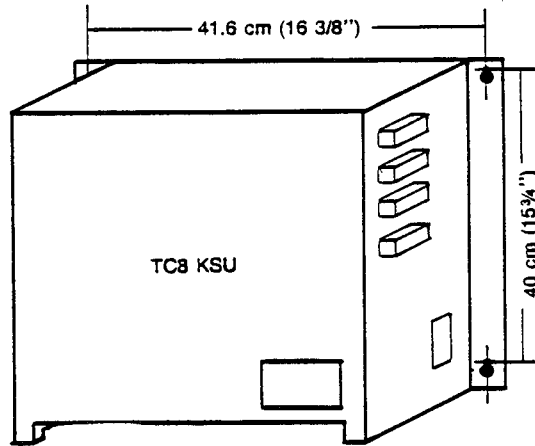

Figure 5-2 KSU MOUNTING CENTERS

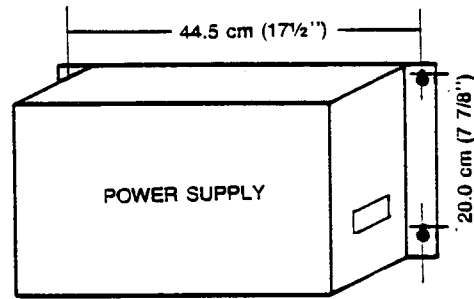

Figure 5-3 POWER SUPPLY MOUNTING CENTERS

4.05 Connect the power supply to the KSU. The power supply cable connectors are located on the right side of both the KSU and the power supply. Connect the surge protector as follows:

- *Install power supply AC plug into surge protector.
- *Turn power supply power switch ON and verify all LED voltage indicators are on.
- *Turn power supply power switch OFF.

CAUTION: DO NOT ALTER CABLE CONNECTING POWER SUPPLY TO THE KSU. ALTERING CABLE WILL CHANGE LEAD RESISTANCE.

4.06 Ground the KSU by connecting a 14 AWG, or heavier, insulated copper wire from the KSU to a cold water pipe or other known ground. The ground wire should be as short as possible. Connect the ground wire to the grounding lug on a cold water pipe on the right side of the KSU (Figure 5-1).

KSU AND PSU INSTALLATION CHECK

- *Mount KSU
- *Mount PSU
- *Connect PSU to KSU
- *Ground KSU

5. INSTALLING PCBS

Static Precautions

5.01 Printed Circuit Board (PCB) assemblies are sensitive to static electricity. When installing or maintaining, use the proper precautions to guard against static damage. The next several paragraphs highlight safe handling techniques for static-sensitive equipment.

5.02 All static-sensitive PCBs are shipped in static-free bags and should be handled only while protected (Figure 5-4).

5.03 To minimize static charges, first discharge any accumulated body static by touching a grounded object and then attach a wrist ground strap. Keep foot movement to a minimum to prevent a charge build-up.

5.04 When working with static-sensitive PCBs, keep the work area free of any objects that may contain a static charge. This includes plastic as well as metal objects. Never slide a PCB across a work surface.

STATIC CHECK

- *Read static precautions

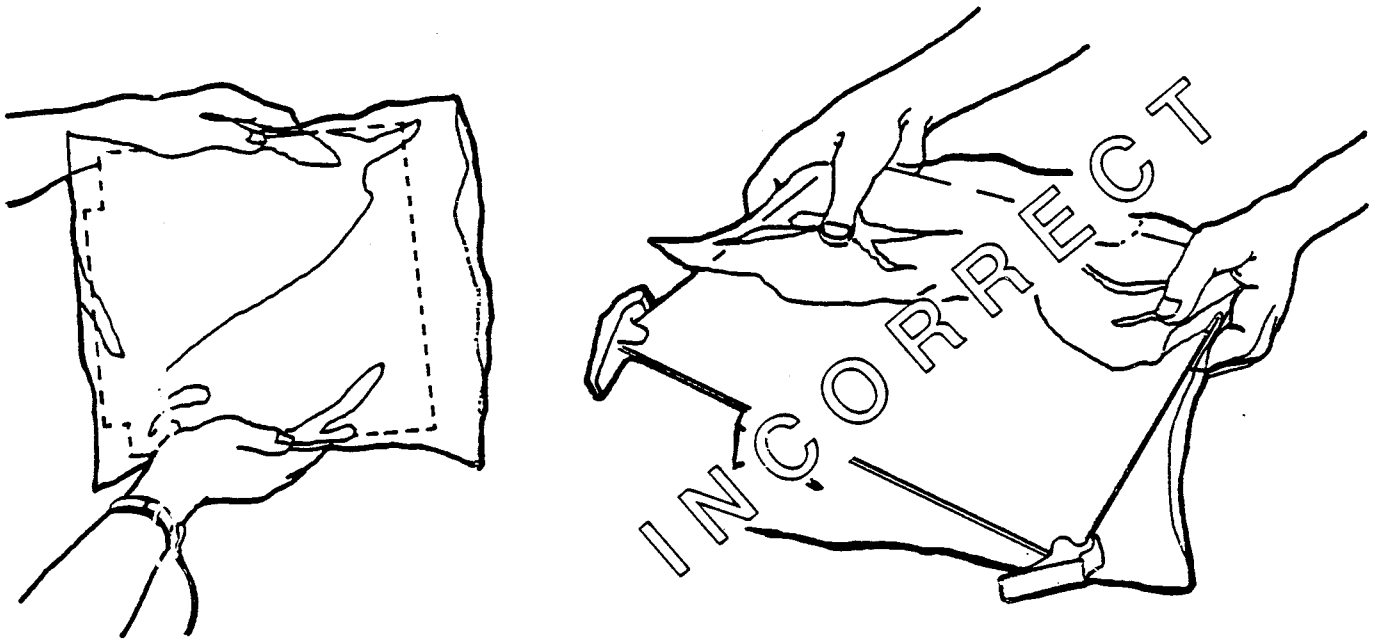

Figure 5-4 HANDLING PCBs

PCB Location

5.05 The PCBs are keyed so that they only fit in their proper slot (Figure 5-5). When inserting the PCBs, the connector edge goes into the slot first with the component side of the PCB to the installers left (Figure 5-6).

5.06 PCBs should be installed with the thumb of each hand on the PCB pulls and the fingers on the KSU frame (Figure 5-6). Push the PCB until firmly seated. Do not use the heel of your hand or any tool to hammer a PCB into a connector.

5.07 Three identification means are used to determine methods of treatment for each PCB. These are as follows:

a. RED PCB EDGE: All PCBs containing static sensitive devices are marked with a RED forward edge and the word "MOS" labeled on the upper PCB pull. These PCBs may be damaged by static discharge and personnel should always use a grounded wrist strap when handling these PCBs.

b. RED PCB PULLS: PCBs which are equipped with RED PCB pulls will disable all or a major part of the system when they are removed from the KSU. Power must always be turned OFF when installing or removing these PCBs.

c. WHITE or NATURAL PCB PULLS: Removal or insertion of these PCBs will not disable the major functions of call processing. Of course, features provided by removed PCBs and associated circuitry located on other PCBs will not function until the PCBs are reinstalled in their proper PCB slots.

5.08 It is recommended that the system be turned OFF to remove PCBs. However, if necessary, the following procedures should be followed when installing or removing PCBs in a working TC-8 DS system.

a. PCBs having RED pulls:

- * Snap on a grounded wrist strap.
- * Turn power OFF.
- * Install or remove PCB.
- * Turn power back on.
- * Checkout system.

b. PCBs having WHITE pulls:

- * Snap on grounded wrist strap.
- * Install or remove PCB.
- * Press XPT CLEAR button (SW4) on A-NMU card for approximately 3 seconds.

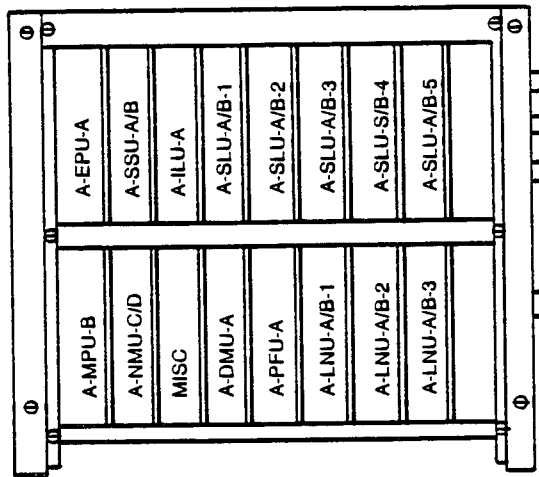

Figure 5-5 TC-8 KSU PCB ARRANGEMENT

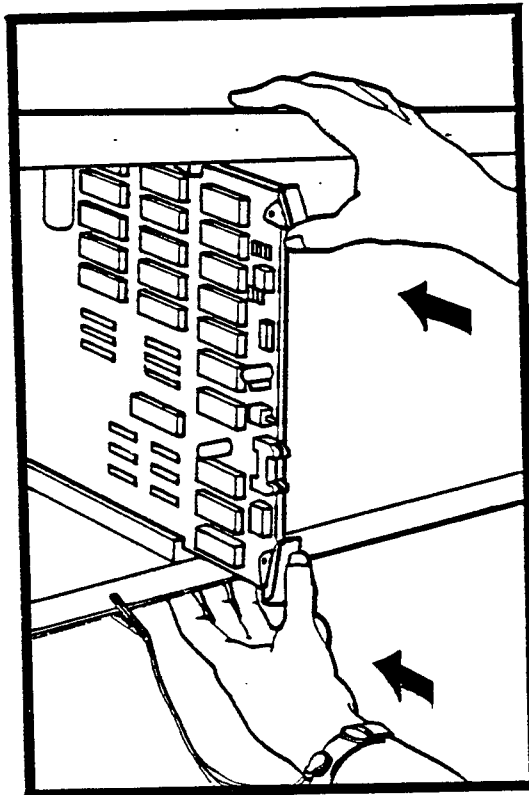

Figure 5-6 INSERTING PCB INTO KSU

- * All stations connected to the A-SLU PCB must be on-hook when the XPT CLEAR button is pressed. If a station is off-hook, the LED (on the A-SLU) for that station will light. If an off-hook indication appears, hang up the handset at that station.
- * Press the XPT CLEAR button again for 3 seconds.
- * Checkout system.

NOTE: Installation of these PCBs while power is ON can result in phantom ring, etc.

Strapping and Setting Switches on PCBs

A-MPU

5.09 The A-MPU-B PCB has four connectors, PR1 through PR4. These connectors should be strapped from 1 to 2 (Figure 5-7).

A-NMU

5.10 The A-NMU PCB has four switches: SW1, SW2, SW3 and SW4. SW1 is used in the power-on initialization program. SW2 and SW3 are used for DSS telephone number assignment. SW3 assigns the number of the primary attendant's telephone, SW2 the secondary attendant's telephone (Figure 5-8). SW4 is the XPT clear switch.

5.11 Each switch (SW2 and SW3), has 8 switches that are set to either 0 or 1. The first four switches set the "tens" digit; the last four switches set the "units" digit of a station number (Figure 5-9). The binary equivalent of a station number determines whether a switch is set as a 0 or 1 (Refer to the Binary Conversion Chart on Figure 5-9 for switch settings).

NOTE: The attendant's telephone is the station preceding the DSS console station number.

5.12 The system can function without a DSS console, but a console must be installed temporarily for programming. If no DSS console is used, after programming set SW2 and SW3 to the FF positions and turn PSU off and on. A DSS console is recommended for future programming updates and troubleshooting.

5.13 If the system is to have one console, set SW2 to the FF position, and SW3 to indicate the station number of the attendant's telephone.

5.14 If two DSS consoles are installed, set SW2 for the station number of the secondary and SW3 for the primary attendant's telephone.

5.15 The A-NMU PCB is equipped with a battery PCB designated BTB-A (Figure 5-8). The battery supplied is a lithium nonrechargeable battery, BR-2/3A,3B. The battery protects the programmed memory during a power failure. Before installing the A-NMU PCB, set SW1 to the OFF position.

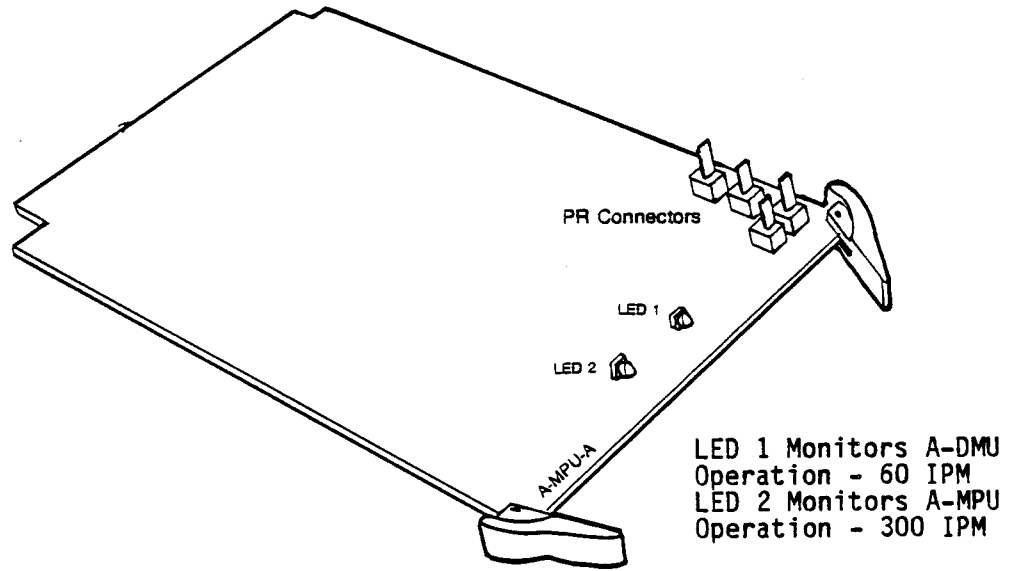

Figure 5-7 A-MPU PCB

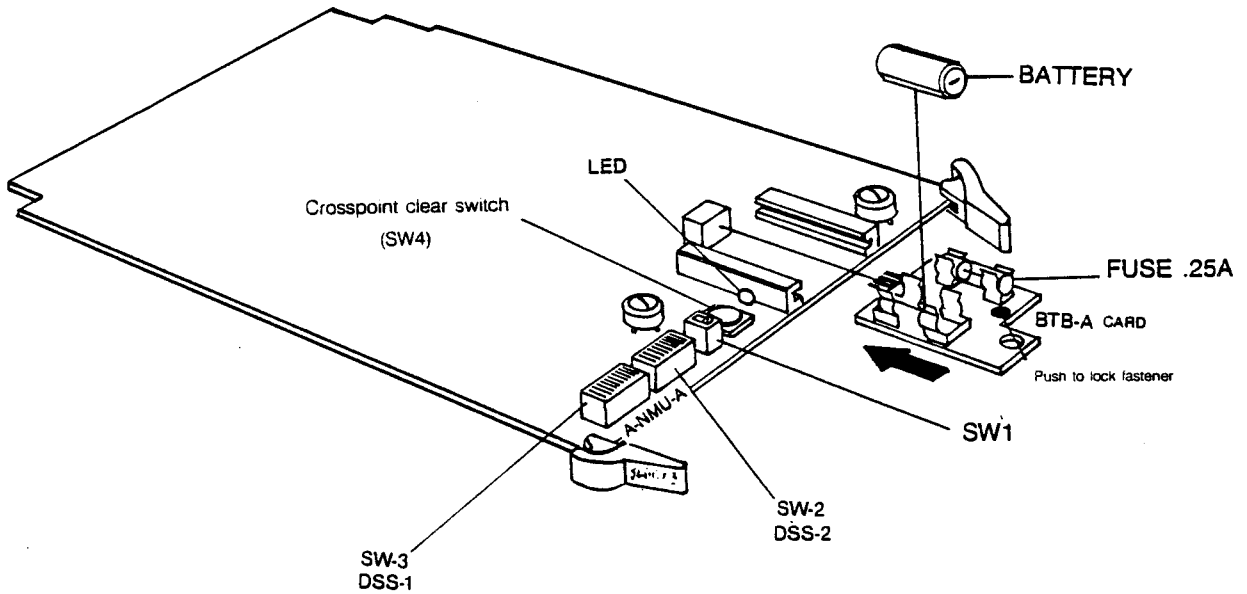
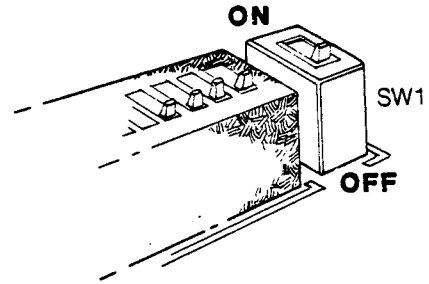
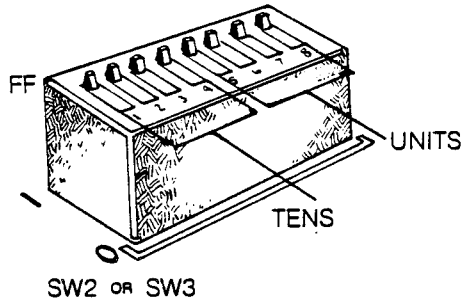

Figure 5-8 A-NMU PCB



DSS Telephone Station Number	DDP Switch Numbers							
	1	2	3	4	5	6	7	8
20	0	0	1	0	0	0	0	0
21	0	0	1	0	0	0	0	1
22	0	0	1	0	0	0	1	0
23	0	0	1	0	0	0	1	1
24	0	0	1	0	0	1	0	0
25	0	0	1	0	0	1	0	1
26	0	0	1	0	0	1	1	0
27	0	0	1	0	0	1	1	1
28	0	0	1	0	1	0	0	0
29	0	0	1	0	1	0	0	1
30	0	0	1	1	0	0	0	0
31	0	0	1	1	0	0	0	1
32	0	0	1	1	0	0	1	0
33	0	0	1	1	0	0	1	1
34	0	0	1	1	0	1	0	0
35	0	0	1	1	0	1	0	1
36	0	0	1	1	0	1	1	0
37	0	0	1	1	0	1	1	1
38	0	0	1	1	1	0	0	0

CONVERSION CHART

Decimal Characters to Binary Bits

Figure 5-9 A-NMU PCB SWITCHES

5.16 On any A-NMU-C/D PCB equipped with BTB-A, the LED on the A-NMU will light and the ALM LED in the DSS console will flash under any of the following fault conditions:

- a. When battery output drops to less than 2.5 volts.
- b. When the fuse blows on BTB-A PCB.
- c. When the battery or BTB-A PCB is removed.

5.17 The battery or fuse on the BTB-A PCB can be replaced while the system is operational and without removing the A-NMU PCB.

CAUTION: Do not remove the battery from its plastic bag until you are ready to install it on the BTB-A PCB. This type of battery may explode or leak if it is recharged, heated, disassembled, short-circuited or incinerated.

BTB-A Installation:

- *Observing polarity designations on battery and BTB-A PCB, install the battery in the battery clips.
- *Insert the BTB-A PCB in the guides, which help align the pins for insertion into the A-NMU mounted connector.
- *Push in the BTB-A PCB until the pins are fully engaged in the connector.
- *Press the push-to-lock fastener. This action secures BTB-A to the A-NMU.

NOTE: When the BTB-A PCB is removed with the battery still installed, DO NOT place the card in a conductive-type static shielding bag.

A-SSU

5.18 There are two A-SSU PCBs, A-SSU-A and A-SSU-B. The A-SSU-A is installed in systems requiring DTMF signaling, the A-SSU-B is installed in systems requiring dial pulse signaling. Strap the HT connector on the A-SSU PCB as follows (Figure 5-10):

- a. 1-2 for internal synthesized music.
- b. 2-3 to use the BGM source for MOH.
- c. Omit strap for NO MOH.

5.19 There are two additional option connectors on the A-SSU-B PCB, PPS AND MR. The PPS connector should be strapped for the desired pulses per second (PPS) output on the CO lines. (Figure 5-10). Strap the PPS connector on the A-SSU PCB as follows:

- a. 1-2 for 20PPS.
- b. 2-3 for 10PPS.

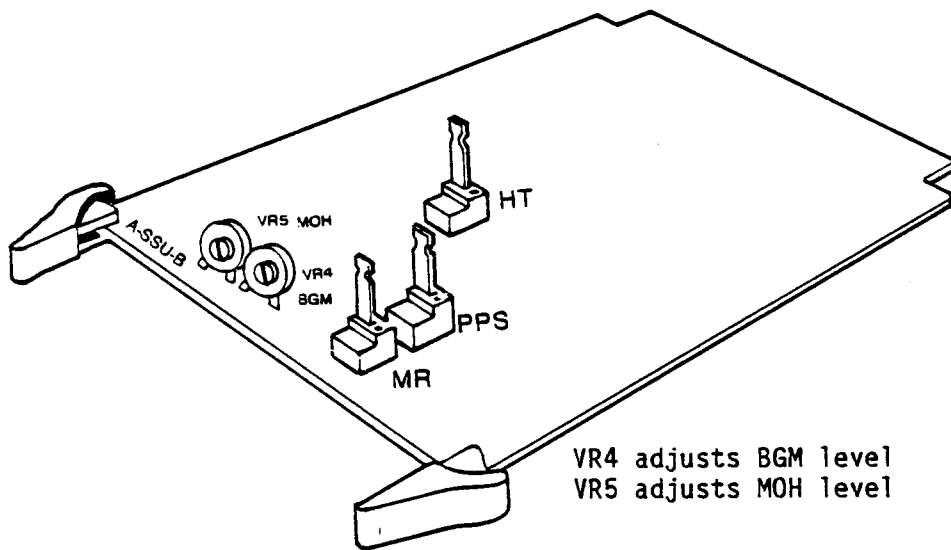
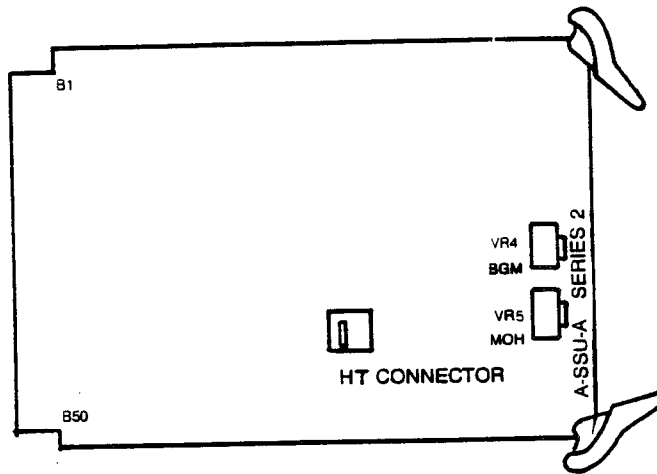

Figure 5-10 A-SSU PCB

5.20 The MR connector determines the make/break ratio of the dial pulses. (Figure 5-10). Strap the MR connector on the A-SSU PCB as follows:

- a. 1-2 provides 39%/61% make/break ratio.
- b. 2-3 provides 33%/67% make/break ratio.

NOTE: Factory strapping 1-2 provides optimum pulsing performance. However, some older types of central offices, loop length or various types of external signaling circuits require strapping 2-3.

A-LNU

5.21 There are two A-LNU PCBs, A-LNU-A and A-LNU-B. The A-LNU-A has two option connectors, DB1 and DB2 (Figure 5-11). The A-LNU-B has one option connector. The key on these connectors should be in position 12 for dial pulse and position 13 for DTMF signaling (Figure 5-11).

5.22 For each CO line there is one HR connector on the A-LNU PCB allowing the system to release lines on hold if the call is abandoned, and disconnect supervision is supplied by the serving CO. There are four HR connectors on the A-LNU-A and two on the A-LNU-B PCB. Strap the HR connectors on the A-LNU PCB as follows (Figure 5-11):

- a. 1-2 for 90 msecs. Step COs
- b. 2-3 for 600 msecs. Electronic COs

The A-LNU circuit designations are as follows:

A-LNU-A-1	Serves lines	1-4
A-LNU-A-2	Serves lines	5-8
A-LNU-A-3	Serves lines	9-12
A-LNU-B-1	Serves lines	3+4
A-LNU-B-2	Serves lines	7+8
A-LNU-B-3	Serves lines	11+12

5.23 The following PCBs have no straps or switch settings and should be installed in the proper KSU slot (Figure 5-12).

	SLOT	A-SLU-A SERVES STATIONS	A-SLU-B SERVES STATIONS
	-----	-----	-----
A-SLU	1	20-23	22-23
	2	24-27	26-27
	3	28-31	30-32
	4	32-35	34-35
	5	36-39	38-39
A-ILU			
A-PFU			
A-EPU			
A-OPU			
A-DMU			

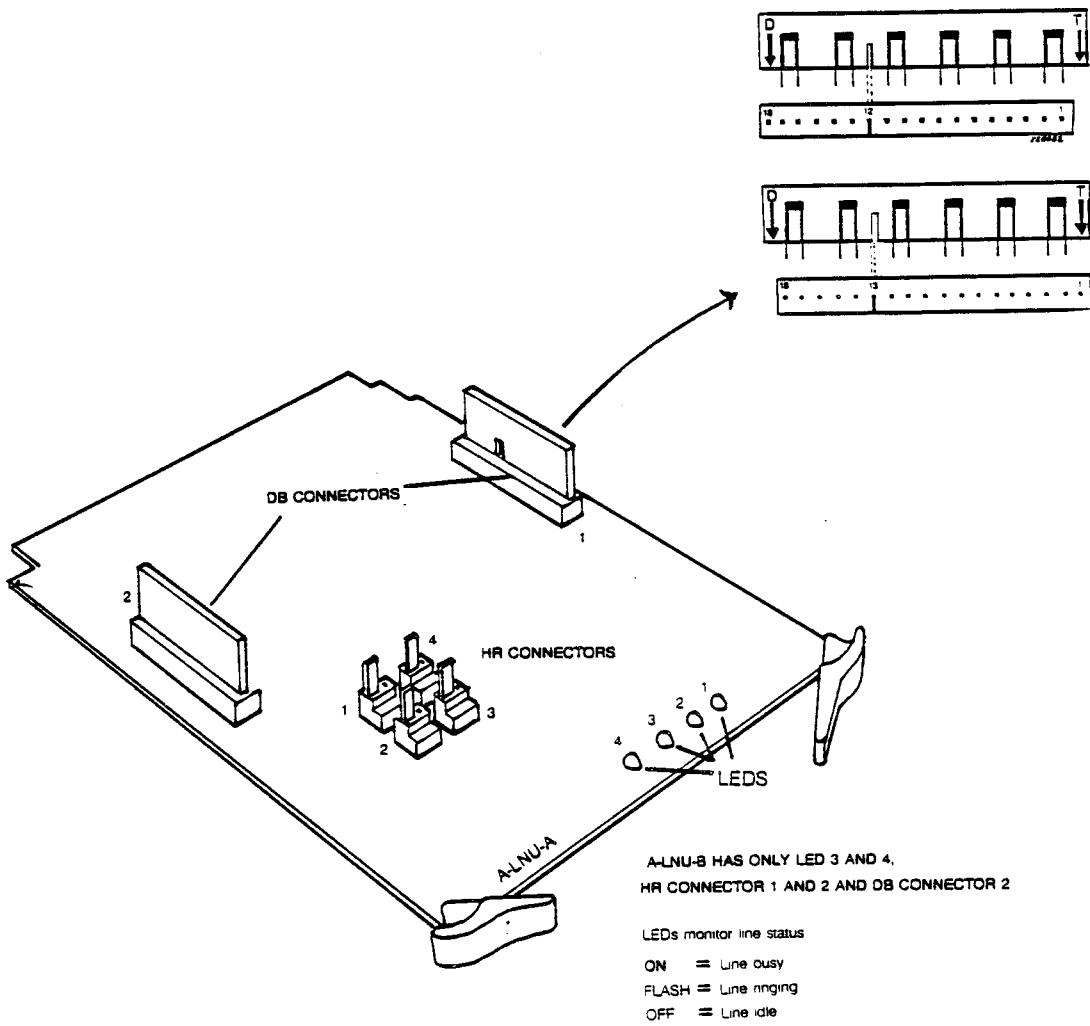
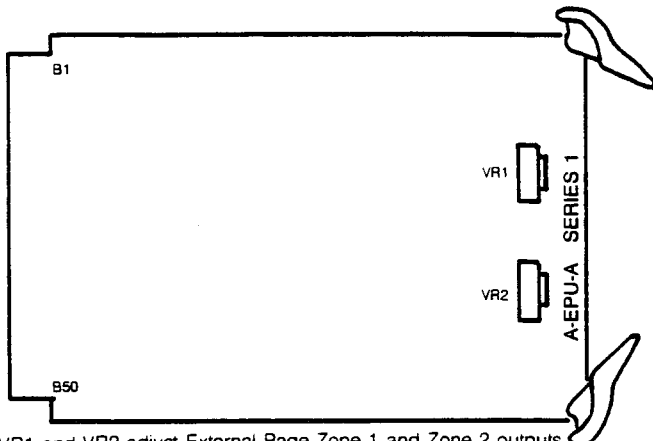
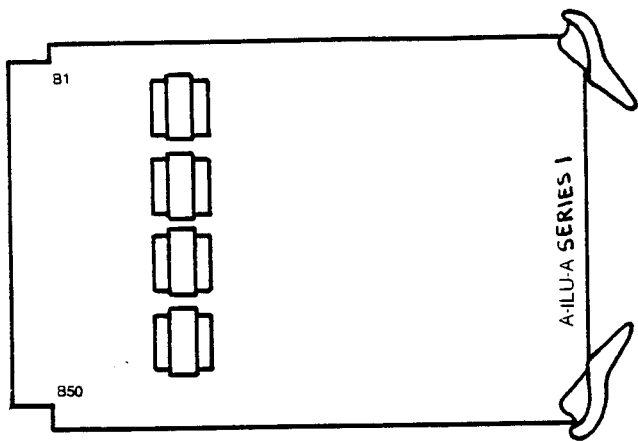

Figure 5-11 A-LNU PCB



VR1 and VR2 adjust External Page Zone 1 and Zone 2 outputs

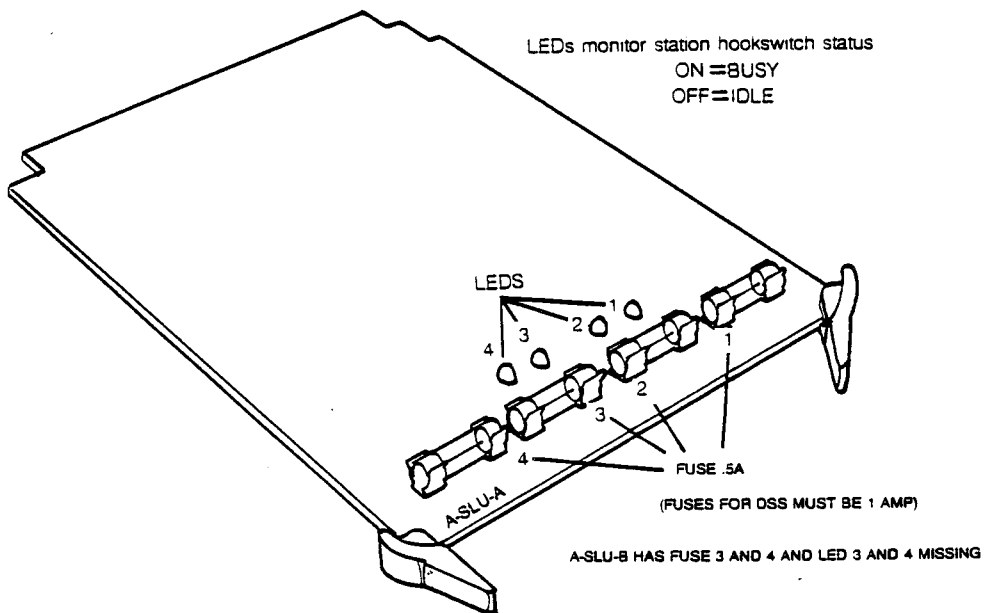
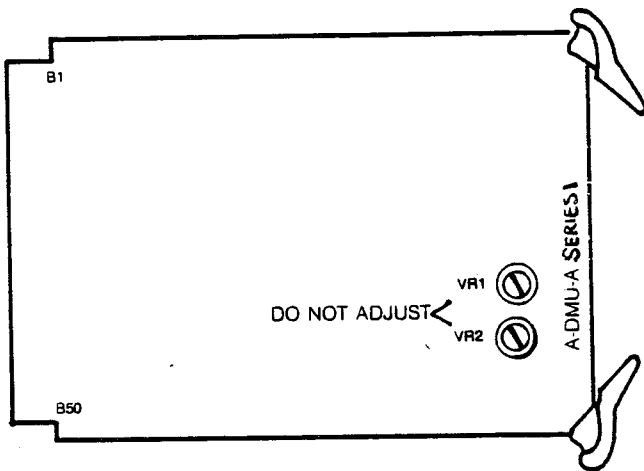
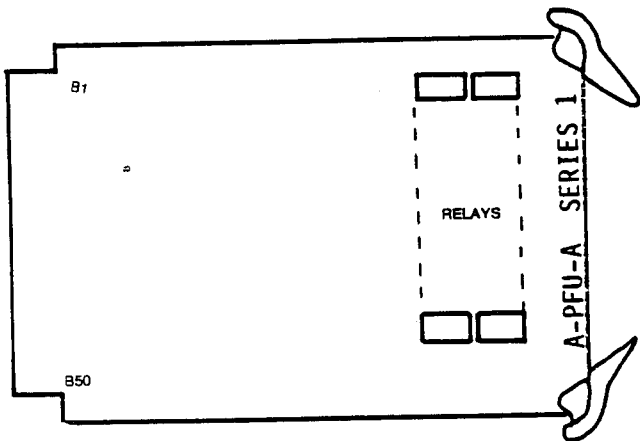

Figure 5-12 PCBs WITHOUT STRAPPING OPTIONS

PCB CHECK

-*Strap and insert PCBs.

6. STATION CABLING AND SYSTEM CONNECTIONS

6.01 Mount the 66M1-50 connecting blocks to the right of the KSU (Figure 5-13). These blocks are recommended for station cable, DSS console cable, external paging, BGM and alarm terminations.

6.02 25-pair cables connect the 66M1-50 connecting blocks to the KSU block. The assignments of stations to the blocks are as follows (Table 5-1):

B1 block - stations 20 through 31

B2 block - stations 32 through 39, external paging, BGM/MOH source, and alarm connections

6.03 Mount station jacks (625A4 or 625F4) at each station location. Two jacks will be required for stations equipped with external power fail ringers.

EQUIPMENT MOUNTING CHECK

-*Mount connecting blocks

-*Mount station jacks

Station Cabling

6.04 Use two-pair twisted station cable from the KSU to the telephones. Station cable is homerun to the connecting block and should not exceed 1,000 feet for 24 AWG wire or 1500 feet for 22AWG wire.

NOTE: Do not use random twisted 4-wire inside cable between the stations and the main Distribution Frame (MDF), as this can cause cross talk and noise on the voice and data pairs.

6.05 Determine the DSS location before terminating the stations cabling. Wire DSS console as any other station.

6.06 Station cabling is terminated at the station blocks and the station jacks (Figure 5-14 and Table 5-1).

NOTE: For proper operation it is important that pair-for-pair connections be maintained and polarity of pairs be observed at all locations where wire terminations or cross-connections are made.

6.07 For non power-fail stations strap the B and C clips of the AT, AR, BT, and BR leads. For ease of trouble shooting bridging clips are recommended.

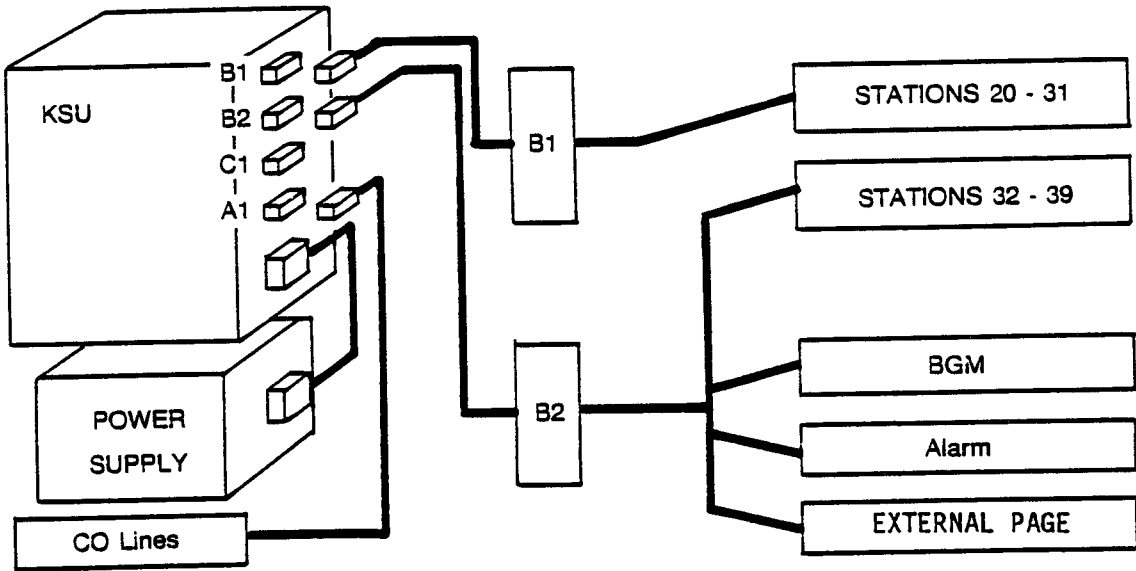

TC-8 SYSTEM WITHOUT POWER FAILURE CIRCUITS

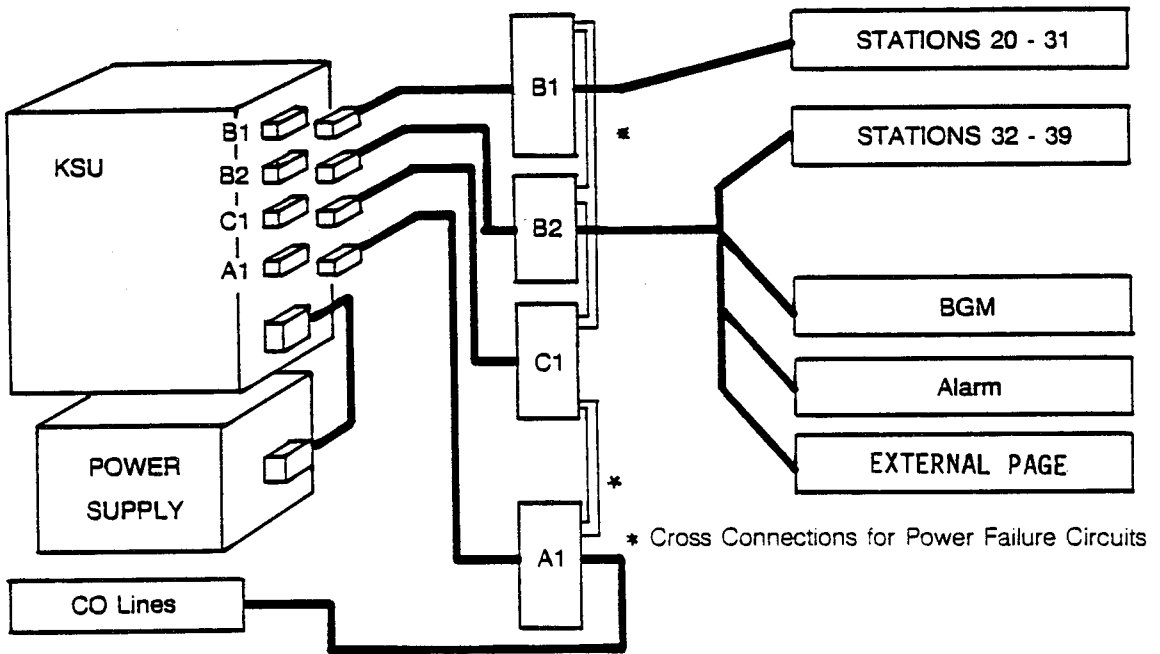

TC-8 SYSTEM WITH POWER FAILURE CIRCUITS

Figure 5-13

Table 5-1 CO LEAD ASSIGNMENTS

CONN PIN	CABLE COLOR	CLIP	BLOCK A1		BLOCK B1		BLOCK B2	
			CIRCUIT NUMBER	LEAD DESIG	STATION NUMBER	LEAD DESIG	STATION NUMBER	LEAD DESIG
26	WH-BL	1	C.O.#1	1T	STA 20	AT	STA 32	AT
1	BL-WH	2		1R		AR		AR
27	WH-OR	3	C.O.#2	2T		BT		BT
2	OR-WH	4		2R	BR	BR		
28	WH-GN	5	C.O.#3	3T	STA 21	AT	STA 33	AT
3	GN-WH	6		3R		AR		AR
29	WH-BR	7	C.O.#4	4T		BT		BT
4	BR-WH	8		4R	BR	BR		
30	WH-SL	9	C.O.#5	5T	STA 22	AT	STA 34	AT
5	SL-WH	10		5R		AR		AR
31	RD-BL	11	C.O.#6	6T		BT		BT
6	BL-RD	12		6R	BR	BR		
32	RD-OR	13	C.O.#7	7T	STA 23	AT	STA 35	AT
7	OR-RD	14		7R		AR		AR
33	RD-GN	15	C.O.#8	8T		BT		BT
8	GN-RD	16		8R	BR	BR		
34	RD-BR	17	HL/PL#1	9T	STA 24	AT	STA 36	AT
9	BR-RD	18		9R		AR		AR
35	RD-SL	19	HL/PL#2	10T		BT		BT
10	SL-RD	20		10R	BR	BR		
36	BK-BL	21	HL/PL#3	11T	STA 25	AT	STA 37	AT
11	BL-BK	22		11R		AR		AR
37	BK-OR	23	HL/PL#4	12T		BT		BT
12	OR-BK	24		12R	BR	BR		
38	BK-GN	25			STA 26	AT	STA 38	AT
13	GN-BK	26				AR		AR
39	BK-BR	27				BT		BT
14	BR-BK	28			STA 27	BR	STA 39	BR
40	BK-SL	29				AT		AT
15	SL-BK	30				AR		AR
41	YL-BL	31			STA 28	BT	BGM	BT
16	BL-YL	32				BR		BR
42	YL-OR	33				AT		AT
17	OR-YL	34			STA 29	BR	MOH*	BR
43	YL-GN	35				AT		AT
18	GN-YL	36				AR		AR
44	YL-BR	37			STA 30	BT	ALM	BT
19	BR-YL	38				BR		BR
45	YL-SL	39				AT		AT
20	SL-YL	40			STA 31	BR	L O U D S P	BR
46	VI-BL	41				AT		AT
21	BL-VI	42				AR		AR
47	VI-OR	43				BT		BT
22	OR-VI	44				BR		BR
48	VI-GN	45				AT		AT
23	GN-VI	46				BR		BR
49	VI-BR	47				AT		AT
24	BR-VI	48				AR		AR
50	VI-SL	49				BT		BT
25	SL-VI	50				BR		BR

* FUTURE

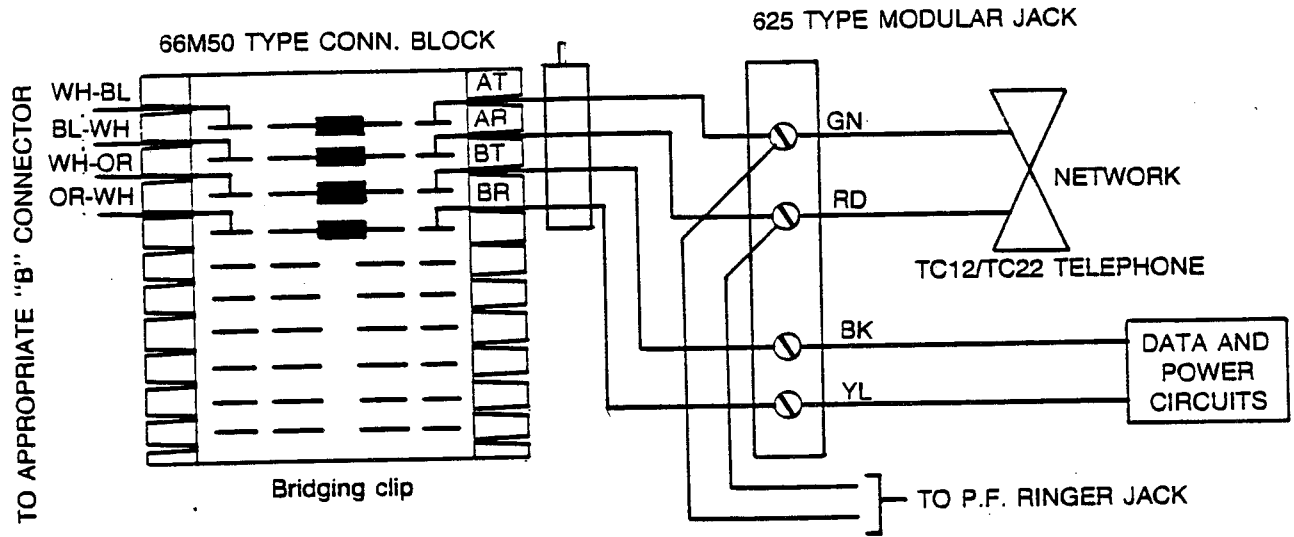

Figure 5-14 KSU TO STATION WIRING

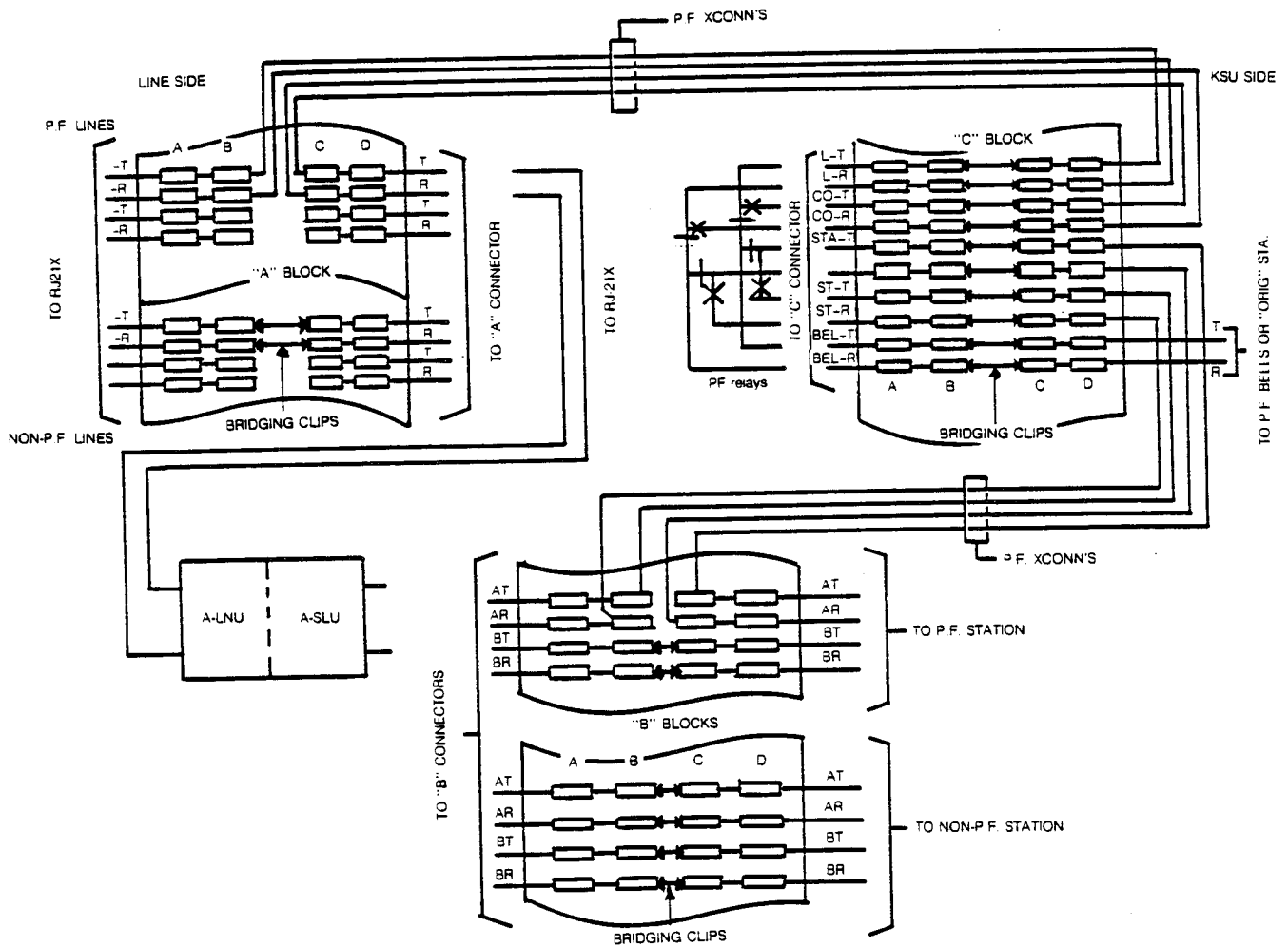

Figure 5-15 POWER FAILURE CONNECTIONS

CO Line Connections

Systems WITHOUT Power Failure Circuits

6.08 On the right side of the KSU is a single 25-pair connector (A1). A 25-pair cable must be connected to the RJ21X connector.

6.09 The 1st 12 pairs of cable are used for the lines. The remaining pairs are vacant (Table 5-1). When power failure circuits are not used, no added installer wiring is required to connect the CO lines to the KSU.

Systems WITH Power Failure Circuits

6.10 When power failure circuits are required in the system, the 25-pair RJ21X connector provided by the telephone company must be plugged into the male (blue) side of a 66M1-50 type connecting block equipped. The female (red) side is connected to the "A" connector of the KSU with a connector ended (red/blue) 25-pair cable. The "A" connecting block must be mounted on an 89-type bracket and equipped with a 66MC cover.

6.11 The 1st 12 pairs (24 clips) on the "A" block are used for the CO lines. The remaining clips are vacant (Table 5-1).

Power Fail Cross Connections

6.12 Each CO line which is to appear at a power-failure station must be connected to an A-PFU-A circuit. These connection points are located on the "C1" block (Figure 5-15 and Table 5-2).

NOTE: Not all CO lines require PF cross-connections.

6.13 Cross-connect the Power fail CO lines of the "A" block to the L and CO clips of the "C" block. (Figure 5-15 and Table 5-2).

6.14 In systems equipped with an A-PFU-A PCB, lines which are NOT connected to power failure circuits must be strapped with bridging clips on the "A" block (Figure 5-15).

6.15 Cross-connect the ST and STA leads of the "C" block to the AT and AR clips of the "B" blocks (Figure 5-15 and Table 5-2).

6.16 Connect the BT/BR leads from the P.F. stations to the "B" blocks as for all other stations and insert bridging clips.

6.17 The BEL leads can be used to terminate a conventional type telephone for P.F. service or for P.F. bells. TIE's BE-5 ringer is recommended for visual and audible indications of an incoming call during power failure condition. One BE-5 is required for every 5 lines.

TABLE 5-2 POWER FAILURE LEAD ASSIGNMENTS

BLOCK C1					
CONN PIN	CABLE COLOR	CLIP	CIRCUIT NUMBER	LEAD DESIG	COMMENTS*
26	WH-BL	1	P.F. #1	L1T	Xconn to B clips on A1 block for 1st P.F. line.
1	BL-WH	2		L1R	
27	WH-OR	3		C01T	Xconn to C clips on A1 block for 1st P.F. line.
2	OR-WH	4		C01R	
28	WH-GN	5		STA1T	Xconn to C clips on B block for 1st P.F. station.
3	GN-WH	6		STA1R	
29	WH-BR	7		ST1T	Xconn to B clips on B block for 1st P.F. station.
4	BR-WH	8		ST1R	
30	WH-SL	9		BEL1T	To 1st P.F. originating station or ringer.
5	SL-WH	10		BEL1R	
31	RD-BL	11	P.F. #2	L2T	Xconn to B clips on A1 block for 2nd P.F. line.
6	BL-RD	12		L2R	
32	RD-OR	13		C02T	Xconn to C clips on A1 block for 2nd P.F. line.
7	OR-RD	14		C02R	
33	RD-GN	15		STA2T	Xconn to C clips on B Block for 2nd P.F. station.
8	GN-RD	16		STA2R	
34	RD-BR	17		ST2T	Xconn to B clips on B block for 2nd P.F. station.
9	BR-RD	18		ST2R	
35	RD-SL	19		BEL2T	To 2nd P.F. originating station or ringer.
10	SL-RD	20		BEL2R	
36	BK-BL	21	P.F. #3	L3T	Xconn to B clips on A1 block for 3rd P.F. line.
11	BL-BK	22		L3R	
37	BK-OR	23		C03T	Xconn to C clips on A1 block for 3rd P.F. line.
12	OR-BK	24		C03R	
38	BK-GN	25		STA3T	Xconn to C clips on B block for 3rd P.F. station.
13	GN-BK	26		STA3R	
39	BK-BR	27		ST3T	Xconn to B clips on B block for 3rd P.F. station.
14	BR-BK	28		ST3R	
40	BK-SL	29		BEL3T	To 3rd P.F. originating station or ringer.
15	SL-BK	30		BEL3R	
41	YL-BL	31	P.F. #4	L4T	Xconn to B clips on A1 block for 4th P.F. line.
16	BL-YL	32		L4R	
42	YL-OR	33		C04T	Xconn to C clips on A1 block for 4th P.F. line.
17	OR-YL	34		C04R	
43	YL-GN	35		STA4T	Xconn to C clips on B block for 4th P.F. station.
18	GN-YL	36		STA4R	
44	YL-BR	37		ST4T	Xconn to B clips on B block for 4th P.F. station.
19	BR-YL	38		ST4R	
45	YL-SL	39		BEL4T	To 4th P.F. originating station or ringer.
20	SL-YL	40		BEL4R	
46	VI-BL	41	P.F. #5	L5T	Xconn to B clips on A1 block for 5th P.F. line.
21	BL-VI	42		L5R	
47	VI-OR	43		C05T	Xconn to C clips on A1 block for 5th P.F. line.
22	OR-VI	44		C05R	
48	VI-GN	45		STA5T	Xconn to C clips on B block for 5th P.F. station.
23	GN-VI	46		STA5R	
49	VI-BR	47		ST5T	Xconn to B clips on B block for 5th P.F. station.
24	BR-VI	48		ST5R	
50	VI-SL	49		BEL5T	To 5th P.F. originating station or ringer.
25	SL-VI	50		BEL5R	

6.18 The PF ringer should be connected to the 1st pair (White-blue, AT/AR leads) of the station cable. Two modular jacks should be installed at the telephone location: one jack for the telephone and the other for the ringer (Figure 5-14). A Proctor single line electronic ringer (Proctor #43732) or any other FCC approved single line high voltage (40-150VAC) ringer can be used. The ringer should be suitable for dual-mounting and equipped with a modular plug.

6.19 The power failure ringer will only ring during power failure conditions. Incoming calls can be answered at the telephone. No calls can be originated from the station unless a TC-22 PF or appropriate single line telephone is used. When a standard key telephone is designated as a PF station, dial tone will be received but dialing will be ineffective.

Private Line Connections

6.20 For installing private and/or hotlines the following combinations are allowed:

Private and/or Hotlines	CO Lines
1	12
2	11
3	10
4	9

NOTE: It is recommended that private or hotlines be put in service in reverse order (e.g. line 12, 11, 10, and line 9 last). This simplifies expansion later on.

6.21 The private CO lines will enter the KSU on the following pairs (Table 5-1): BK-OR/OR-BK (line 12), BK-BL/BL-BK (line 11), RD-SL/SL-RD (line 10) and RD-BR/BR-RD (line 9). Install bridging clips if required.

6.22 The CO line appearance for the private line has no relationship to the private line/hotline key location at the station.

Background Music Connections

6.23 When background music (BGM) or music-on-hold (MOH) is required, a customer-provided music source must be provided. (Internal synthesized music source can be used for MOH). The source can be a radio, tuner, tape deck, piped-in-music, etc.

6.24 BGM provides music through the loudspeakers in the telephones of the system. Music can also be programmed to broadcast over an optional external paging system.

6.25 The music source should have an adjustable output level between -30 dbm and 0 dbm and an output impedance of 600 ohms or less.

6.26 The output from the music source should be connected to clips 35/36 of the B2 block. Twisted pair wire can be used between the music source and the station block. Install bridging clips on the B2 block.

External Paging Zone Connections

6.27 A maximum of two external paging zones can be provided. Each zone has a maximum output power of 3 watts with an 8 ohm output impedance. If more than 3 watts are required in a zone, customer-provided amplifier(s) will be required.

6.28 If external amplifiers are not required, the external zone loudspeakers can be directly connected to clips 41/42 and 45/46 on the B2 block. The maximum distance between the KSU and external speakers is 300 feet, using 22 AWG wire in an 8-ohm load.

6.29 If external amplifiers are required, twisted pair wire can be used between the amplifiers and the station block. Connect the amplifier inputs to clips 41/42 for zone 1 and 45/46 for zone 2. Install bridging clips on the B2 block.

6.30 Separate external zone paging level controls are provided on the A-EPU PCB. These controls VR1 and VR2 (Figure 5-12) should be adjusted after the system is operational.

6.31 Dry contacts are provided for auxiliary purposes when the A-EPU PCB is used. The contacts are rated at 1.25A for 24VDC resistive loads. These contacts are activated whenever the paging amplifiers are in use, including CO audible and BGM if programmed.

6.32 The contacts appear on the B2 block clips 43/44 (1S1/1S2) for zone one and clips 47/48 (2S1/2S2) for zone two. Install bridging clips on the B2 block.

Alarm Connections

6.33 The system provides for alarm indications from a customer-owned security system to be transmitted to all telephones in the system if the DSS console is not attended in the NT mode or to the DSS attendant. Provision is made for either open or closed alarm circuit activation. Programming is done from the DSS console.

6.34 The alarm input pair should be connected to clips 39/40 on the B2 block. Install bridging clips on the B2 block.

SYSTEM CABLING CHECK

- *Home run all station cable
- *Terminate cable in modular jack at station location
- *Make all system connections
- *Install bridging clips as required

7. STATION INSTALLATION

7.01 Prior to installing the key telephones the following voltage tests should be conducted at each station jack with power on to verify proper wiring:

Terminals -----	Voltage (Vdc) -----
AT to AR	Max 18 Vdc
BT to BR	Min 24 Vdc

7.02 There is no need to open key telephones or power failure telephones for installation, unless a TC-402 speakerphone is to be installed (refer to Section 9). Simply plug the set into its modular jack.

8. INSTALLATION CHECK

8.01 Verify that the installation is in accordance with this manual. Use the Installation Checklist below.

INSTALLATION CHECKLIST

- MOUNTING SURFACE -- Check that exterior-grade plywood is used as the backboard on damp mounting surfaces.
- AC LINE -- Check that AC line is dedicated exclusively to the system.
- AT THE SERVICE ENTRANCE PANEL -- Check that circuit breaker switch is equipped with a lock-clip to ENTRANCE PANEL to prevent accidental shutdown.
- POWER OUTLET -- Check that power outlet is a 3-wire grounded outlet for receiving 115 VAC plug having parallel blades and ground pin. Do not use a 3-wire to 2-wire adapter.
- POWER OUTLET -- Check that input power line has the capacity to deliver 15 amperes (RMS).
- SURGE PROTECTION -- Check that Surge Protector is installed on input Power Line.

- VENTILATION AND TEMPERATURE -- Check that site is adequately ventilated with a temperature range of 40 to 100 degrees F (4 to 38 degrees C) and a relative, non-condensing humidity range of 5% to 95%.
- EARTH GROUND -- Check that a proper earth ground connection to the KSU is made using at least 14 AWG wire.
- SERVICEABILITY -- Check that lighting conditions and the amount of working space are adequate for future service.
- KSU -- Check that the 1/4" KSU hanger bolts have been tightened sufficiently.
- POWER SUPPLY -- Check that the 1/4" power supply hanger bolts have been tightened sufficiently.
- A, B, and C BLOCKS -- Check that bridging clips have been installed as required.
- FUSES -- Check that fuse ratings are correct.
- PRINTED CIRCUIT BOARDS -- Check that PCBs are correctly strapped and switches properly set.
- PRINTED CIRCUIT BOARDS -- Check that all PCBs are installed properly.

9. RADIO FREQUENCY INTERFERENCE

9.01 If the system is not installed and used according to the manufacturer's instructions, this equipment can interfere with radio and television reception. It has been type-tested and found to comply with the limits for a Class A computing device, according to specifications in FCC Rules covering protection against such interference in a commercial installation. However, there is no guarantee that interference will not occur in a particular installation. Interference to radio or television reception caused by this equipment can be determined by turning the equipment off and on. If an interference problem exists, the problem can be solved in one or more of the following ways:

- a. Re-orient the receiving antenna.
- b. Relocate the receiver with respect to the equipment.
- c. Plug the equipment and receiver into different branch circuits.

9.02 If necessary, consult your dealer for additional assistance. The following booklet, prepared by the FCC, can be helpful:

HOW TO IDENTIFY AND REMOVE RADIO-TV INTERFERENCE PROBLEMS

Order this booklet from:

U.S. Government Printing Office
Washington, D.C. 20402
(Stock N. 004-000-00345-4).

10. CONNECTING TELCO LINES

10.01 Each RJ21X connector from telco provides service for the 12 system CO lines. The RJ21X connector is joined to the TC-8 DS system using a 25-pair cable terminated with a 25-pair connector at the other end. This cable cannot exceed 25 feet in length.

10.02 Lines 1 through 12 are on connector "A1" at the KSU. These lines are connected via a 25-pair cable from "A1" to the RJ21X from telco.

TC-8 DS

ELECTRONIC KEY TELEPHONE SYSTEM

SECTION 6, PROGRAMMING

1. INTRODUCTION

1.01 The PROGRAMMING section describes the programming, system initialization and program reading procedures for the TC-8 DS system. All data needed for programming has been entered on the Program Record Form (PRF) completed in Section 4.

1.02 This paragraph is reserved for summarizing major revisions to this section.

2. SYSTEM INITIALIZATION

2.01 The system must be initialized prior to programming option codes. Initialization loads the factory installed program into the system memory. To initialize the system:

- *Turn OFF power supply.
- *Set SW1 switch on the A-NMU PCB to the OFF position.
- *Turn ON power supply. The factory installed program has now been loaded to the system memory.
- *After approximately 10 seconds, set SW1 switch on the A-NMU PCB to the ON position.

NOTE: Do not initialize the system when reprogramming. Initialization erases all option codes entered.

2.02 The factory installed program configures the system as follows:

- (a) DSS attendants' station numbers are set according to the positions of switches SW2 & SW3 on the A-NMU PCB.
- (b) No line ring groups are assigned.
- (c) Station 20 is assigned for programming system based speed dial numbers.
- (d) The system has DTMF CO line signaling.
- (e) Internal page zones:
 - Zone 1- stations 20-24
 - Zone 2- stations 25-29
 - Zone 3- stations 30-34
 - Zone 4- stations 35-39

3. PROGRAMMING

3.01 To program option codes, the system must be in the programming mode. To place the system in the programming mode:

- *Remove primary DSS console faceplate.
- *Press DATA ENTRY key. MW key illuminates and the system stops processing calls.
- *Place primary DSS station handset off-hook.

3.02 When programming has been completed:

- *Place primary DSS station on hook.
- *Press DATA ENTRY key.
- *Replace primary DSS console faceplate.

NOTE: If, after pressing the DATA ENTRY Key, the alarm sounds at the console, a conflict exists in the data entered. Return to the programming mode and review data input for the programs whose DSS console key LED's are lit and correct the conflict.

3.03 If a specific program requires modification at a later date then the procedure for placing the console in the programming mode must be followed. Do NOT initialize the system again. Initializing erases all previously selected option codes. Record all changes on the Options Configuration Worksheet (OCW) and on the PRFs to keep all information up to date.

3.04 The following paragraphs describe the procedures for entering data into each program.

3.05 Program 20, Line Ring Groups. To program Line Ring Groups press DSS console Key 20 and proceed as follows:

- *Enter line ring group number from the PRF
- *Press *
- *Enter lowest CO line number from A/B boxes on the PRF
- *Press *
- *Enter highest CO line number from C/D boxes on the PRF
- *Press *, repeat procedure for remaining ring groups
- *Press #, to exit program

3.06 Program 21, Day Ring Group Stations. To program Day Ring Group Stations press DSS console Key 21 and proceed as follows:

- *Enter station number from the A/B boxes on the PRF
- *Press *
- *Enter line ring group number from C/D boxes on the PRF
- *Press *, repeat procedure for remaining stations
- *Press #, to exit program

3.07 Program 22, System Speed Dial. To program the station to enter System Speed Dial numbers press DSS console Key 22 and proceed as follows:

- *Enter the station number from C/D boxes on the PRF
- *Press *
- *Press #, to exit program

3.08 Program 23, Meet-Me-Conference. To program Meet-Me-Conference press DSS console Key 23 and proceed as follows:

- *Enter data from D box on the PRF
- *Press *
- *Press #, to exit program

CODE: "1", feature is desired; "0", not desired.

3.09 Program 24, Barge-In. To program Barge-In press DSS console Key 24 and proceed as follows:

- *Enter station number from the A/B boxes on the PRF
- *Press *
- *Enter data from D box on the PRF
- *Press *, repeat procedure for remaining stations
- *Press #, to exit program

CODE: "1", feature is desired; "0", not desired.

3.10 Program 25, I-Hold Reminder. To program I-Hold Reminder press DSS console Key 25 and proceed as follows:

- *Enter 1 for first input from B box on the PRF
- *Press *
- *Enter code for amount of time between each reminder signal from C/D boxes on the PRF
- *Press *
- *Enter 2 for second input from B box on the PRF
- *Press *
- *Enter code for duration of reminder signal from C/D boxes on the PRF
- *Press *
- *Press #, to exit program

Programs 26-28 not used

3.11 Program 29, Off-Hook Signaling and DSS Override. To program Off-Hook Signaling and DSS Override press DSS console Key 29 and proceed as follows:

- *Enter data from D box on the PRF
- *Press *
- *Press #, to exit program

CODE: "0", neither feature is desired; "1", Off-Hook Signaling only; "2", DSS Override only; "3", both features desired.

3.12 Program 30, DTMF Off-Premise Station. To program DTMF Off-Premise Station press DSS console Key 30 and proceed as follows:

- *Enter station number from the A/B boxes on the PRF
- *Press *
- *Enter data from D box on the PRF
- *Press *
- *Press #, to exit program

CODE: "1", DTMF is desired for OPS; "0", all other stations.

3.13 Program 31, Do-Not-Disturb. To program Do-Not-Disturb press DSS console Key 31 and proceed as follows:

- *Enter station number from the A/B boxes on the PRF
- *Press *
- *Enter data from D box on the PRF
- *Press *, repeat procedure for remaining stations
- *Press #, to exit program

CODE: "1", feature is desired; "0", not desired.

3.14 Program 32, Recall Timing. To program Recall Timing press DSS console Key 32 and proceed as follows:

- *Enter 1 for first input from B box on the PRF
- *Press *
- *Enter code for amount of time before recall signal from C/D boxes on the PRF
- *Press *
- *Enter 2 for second input from B box on the PRF
- *Press *
- *Enter code for duration of recall signal from C/D boxes on the PRF
- *Press *
- *Press #, to exit program

3.15 Program 33, CO Line Signaling. To program CO Line Signaling press DSS console Key 33 and proceed as follows:

- *Enter data from D box on the PRF
- *Press *
- *Press #, to exit program

CODE: "1", Dial pulse; "0", DTMF.

3.16 Program 34, PBX Lines. To program PBX Lines press DSS console Key 34 and proceed as follows:

- *Enter line number from the A/B boxes on the PRF
- *Press *
- *Enter data from D box on the PRF
- *Press *, repeat procedure for remaining lines
- *Press #, to exit program

CODE: "1", PBX operation; "0", normal CO line operation.

3.17 Program 35, Flash Key. To program Flash Key press DSS console Key 35 and proceed as follows:

- *Enter code for flash interval from C/D boxes on the PRF
- *Press *
- *Press #, to exit program

3.18 Program 36, Meet-Me-Page. To program Meet-Me-Page press DSS console Key 36 and proceed as follows:

- *Enter data from D box on the PRF
- *Press *
- *Press #, to exit program

CODE: "1", feature is desired; "0", not desired.

3.19 Program 37, Queue Group Restrictions. To program Queue Group Restrictions press DSS console Key 37 and proceed as follows:

- *Enter data from B box on the PRF
- *Press *
- *Enter queue group number from D box on the PRF
- *Press *, repeat for remaining entries
- *Press #, to exit program

3.20 Program 38, Outgoing Station Restrictions. To program Outgoing Station Restrictions press DSS console Key 38 and proceed as follows:

- *Enter station number from the A/B boxes on the PRF
- *Press *
- *Enter data from D box on the PRF
- *Press *, repeat procedure for remaining stations
- *Press #, to exit program

CODE: "1", deny; "0", allow access.

3.21 Program 39, Station Class of Service. To program Station Class of Service press DSS console Key 39 and proceed as follows:

- *Enter station number from the A/B boxes on the PRF
- *Press *
- *Enter COS code (0-8) from D box on the PRF
- *Press *, repeat procedure for remaining stations
- *Press #, to exit program

3.22 Program 40, Queue Groups. To program Queue Groups press DSS console Key 40 and proceed as follows:

- *Enter CO Line number from the A/B boxes on the PRF
- *Press *
- *Enter queue group code (0-5) from D box on the PRF
- *Press *, repeat procedure for remaining lines
- *Press #, to exit program

3.23 Program 41, Permitted Codes. To program Permitted Codes press DSS console Key 41 and proceed as follows:

- *Enter each digit of a permitted code from the D box on the PRF
- *Press *, repeat procedure for remaining codes
- *Press # repeatedly until display shows "0000"

3.24 Program 42, Permitted Code Digits. To program Permitted Code Digits press DSS console Key 42 and proceed as follows:

- *Enter maximum number of digits from C/D boxes on the PRF
- *Press *
- *Press #, to exit program

3.25 Program 43, "0" or "1" in 2nd Digit. To program "0" or "1" in 2nd Digit press DSS console Key 43 and proceed as follows:

- *Enter data from D box on the PRF
- *Press *
- *Press #, to exit program

CODE: "1", allow; "0", deny dialing.

3.26 Program 44, PBX Access Codes. To program PBX Access Codes press DSS console Key 44 and proceed as follows:

- *Enter each digit of an access code from the D box on the PRF
- *Press *, repeat procedure for remaining codes
- *Press # repeatedly until display shows "0000"

3.27 Program 45, Common Unrestricted Codes. To program Common Unrestricted Codes press DSS console Key 45 and proceed as follows:

- *Enter each digit of a code from the D box on the PRF
- *Press *, repeat procedure for remaining codes
- *Press # repeatedly until display shows "0000"

3.28 Program 46, Digit Absorbing. To program Digit Absorbing press DSS console Key 46 and proceed as follows:

- *Enter each digit from the D box on the PRF
- *Press *, repeat procedure for remaining digits
- *Press # repeatedly until display shows "0000"

3.29 Programs 47-50, Executive Call Forward. To program Executive Call Forward press DSS console Key 47, 48, 49 or 50 and proceed as follows:

- *Enter Executive's station number from A/B boxes on the PRF
- *Press *
- *Enter other station number in pair from C/D boxes on the PRF
- *Press *
- *Press #, to exit program