



# TECHNICAL Practice

**TELECOM SOLUTIONS FOR THE 21ST CENTURY**

**C-3000**

**Apartment Entry  
System**

December 18, 2002

## Add Apartment Entry Without Rewiring



This entry system is designed to utilize a building's existing telephone wiring and to address a variety of apartment entry applications. Viking's **C-3000** Entry System provides secure multi-tenant building access, without the need for any C.O. lines; the only requirement is that each tenant have a touch-tone telephone set wired to their apartment. Conversely, the **C-3000** performs equally as well in installations where C.O. lines are present. An individual **C-3000** module has a 12-tenant capacity; for larger applications, a maximum of eight (8) **C-3000** modules can be interconnected, allowing a total system capacity of up to 96 tenants. A **C-3000** system consists of at least one Master **C-3000** module, and as many as seven Slave modules.

From either of two entry doors, visitors may ring a tenant's telephone with a distinctive cadence, alerting the tenant of their arrival. The **C-3000** provides call waiting tones if the tenant's line is in use. The tenant may then converse freely with the visitor via their existing telephones. Once identified, the tenant can elect to allow the visitor entry, by entering a single touch-tone on the keypad of the tenant's telephone set.

The **C-3000** keyless entry feature supports unique entry codes for each tenant. As a measure of security, the codes can be easily changed as tenants move in and out of the building. A postal lock feature is also supplied as an added convenience.

## Features

- Utilizes building's existing telephone wiring, yet functions with or without tenant CO lines
- No monthly charges for a dedicated line
- Tenants do not require phone service
- Programmable keyless entry code for each tenant
- Distinctive ring cadence and call waiting
- Remotely programmable from dedicated programming phone
- Supports (2) entry doors and (2) door strikes
- 12-tenant capacity may be expanded to 96 tenants at any time
- Compatible with **Viking's** vandal resistant **K-1700-3**, **K-1900-8** or any Touch Tone phone
- May be wired so that tenants may talk to visitors without disrupting C.O. modem transmissions
- Allows visitors to leave voice messages on tenants personal answering machines

## Applications

- Apartments and condominiums
- Buildings where some or all tenants lack phone service
- Supervised living
- Student housing
- Retrofit older construction

**Phone... 715.386.8861**

**info@vikingelectronics.com**

**http://www.vikingelectronics.com**

## Specifications

**Power:** 120VAC / 13.8VAC 1.25A, UL listed adapter provided  
**Dimensions:** 211mm x 160mm x 46mm (8.30" x 6.30" x 1.80")  
**Shipping weight:** 1.0kg (2.2 lbs.)  
**Environmental:** 0c to 32c (32F to 90F)  
**Talk battery:** 40VDC  
**Relay contact ratings:** 5A @ 30VDC / 250VAC  
**Maximum System Door Phones/Door Strikes:** (2) each  
**Maximum System Tenant Capacity:** 96 - using (8) **C-3000** modules  
**Ring Generator:** 90V AC nominal, 7 REN maximum  
**Connections:** (1) RJ-21X female 25-pair, (3) RJ-11 female, (12) terminal block positions

# Installation

## A. Definitions

**Master Module:** The **C-3000** module assigned module ID #1. Also, the only module in a single-module system.

**Slave Module(s):** Any module(s) in addition to the Master, in a multi-module **C-3000** system. Slave modules are assigned module ID numbers in the range of #2 through #8.

**"66" Punchdown Terminal Block:** A connection peripheral used to interface telephone lines easily. This installation requires a "split" punchdown block.

## B. Preparing the Installation

Select an appropriate location in which to install the **C-3000** System. It is normally most convenient to install the **C-3000** modules as near as possible to the telco demarcation point; that is, the common point at which all tenant phone lines enter the building (if applicable). If the tenant phone wiring is not currently cabled through a "66" block or blocks, it will be necessary to install "66" block(s) at this time to facilitate the installation of the **C-3000** system. **Note:** See the installation diagram on the following page for recommendations on which "66" block to use.

## C. Assigning Module ID Numbers

A **C-3000** system consists of at least one (Master) **C-3000** module, and as many as seven (7) Slave modules. Multiple **C-3000** modules are all interconnected from module to module, using the supplied modular cords, connecting the MULTI-MODULE INTERCONNECTS from IN to OUT. If more than one **C-3000** module is being installed, it will be necessary to set module ID numbers at this time. Each **C-3000** module must have it's own ID number to be part of a **C-3000** system. Module ID numbers are set using the three-position DIP switches on the front of the **C-3000** modules (see diagram below). Module ID numbers are used to determine which **C-3000** module is responsible for handling a particular range of apartment numbers. As an example, Module #1 (the Master module) handles apartment numbers 1-12, Module #2 handles apartment numbers 13-24 and so forth.

## D. Wiring Table

Refer to the wiring table below when installing the cabling for the **C-3000** system. Note that tenant line 1 enters on pins 1 & 26 of the RJ-21X connector, and exits on pins 2 & 27 of the same connector. This also means a visitor would dial a touch tone 1 to call the tenant connected to line 1. This scheme is used on all 12 lines on the RJ-21X connector, occupying all pins up through the pin 24 & 49 pair, and repeats on up to the 96th tenant on the 8th module. The last pair on the RJ-21X connector (pins 25 & 50) has a special function. This last pair is used (on the Master module only) as a connection for the Building Manager's Programming Phone.

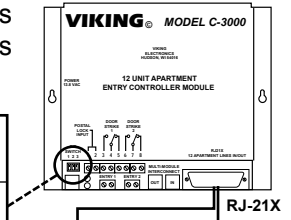

Module ID Assignment	Module 1 "Master"	Module 2 "Slave"	Module 3 "Slave"	Module 4 "Slave"	Module 5 "Slave"	Module 6 "Slave"	Module 7 "Slave"	Module 8 "Slave"		
	ON OFF 1 2 3	ON OFF 1 2 3	ON OFF 1 2 3	ON OFF 1 2 3	ON OFF 1 2 3	ON OFF 1 2 3	ON OFF 1 2 3	ON OFF 1 2 3	Tip	Ring
C.O. Lines In	1	13	25	37	49	61	73	85	26 W/BL	1 BL/W
	2	14	26	38	50	62	74	86	28 W/G	3 G/W
	3	15	27	39	51	63	75	87	30 W/S	5 S/W
	4	16	28	40	52	64	76	88	32 R/O	7 O/R
	5	17	29	41	53	65	77	89	34 R/BN	9 BN/R
	6	18	30	42	54	66	78	90	36 BK/BL	11 BL/BK
	7	19	31	43	55	67	79	91	38 BK/G	13 G/BK
	8	20	32	44	56	68	80	92	40 BK/S	15 S/BK
	9	21	33	45	57	69	81	93	42 Y/O	17 O/Y
	10	22	34	46	58	70	82	94	44 Y/BN	19 BN/Y
	11	23	35	47	59	71	83	95	46 B/BL	21 BL/B
	12	24	36	48	60	72	84	96	48 V/G	23 G/V
Lines Out to Apartment Phones (Dial Up Codes)	1	13	25	37	49	61	73	85	27 W/O	2 O/W
	2	14	26	38	50	62	74	86	29 W/BN	4 BN/W
	3	15	27	39	51	63	75	87	31 R/BL	6 BL/R
	4	16	28	40	52	64	76	88	33 R/G	8 G/R
	5	17	29	41	53	65	77	89	35 R/S	10 S/R
	6	18	30	42	54	66	78	90	37 BK/O	12 O/BK
	7	19	31	43	55	67	79	91	39 BK/BN	14 BN/BK
	8	20	32	44	56	68	80	92	41 Y/BL	16 BL/Y
	9	21	33	45	57	69	81	93	43 Y/G	18 G/Y
	10	22	34	46	58	70	82	94	45 Y/S	20 S/Y
	11	23	35	47	59	71	83	95	47 V/O	22 O/V
	12	24	36	48	60	72	84	96	49 V/BN	24 BN/V
Bldg Mgr Phn	n/a	n/a	n/a	n/a	n/a	n/a	n/a	n/a	50 V/S	25 S/V

# E. Standard Wiring

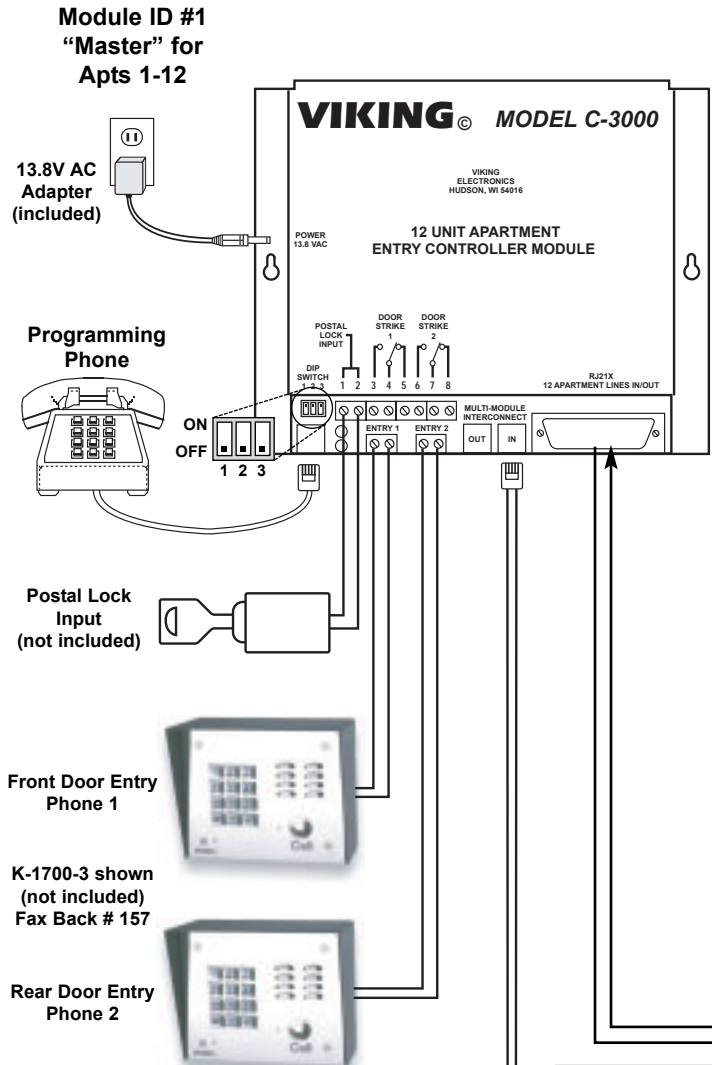

Bridged		Bridged	
Row 1 C.O. Lines	Row 2 C-3000	Row 3 C-3000	Row 4 Apt Phns
1T	26 W/BL	27 W/O	1T
1R	1 BL/W	2 O/W	1R
2T	28 W/G	29 W/BN	2T
2R	3 G/W	4 BN/W	2R
3T	30 W/S	31 R/BL	3T
3R	5 S/W	6 BL/R	3R
4T	32 R/O	33 R/G	4T
4R	7 O/R	8 G/R	4R
5T	34 R/BN	35 R/S	5T
5R	9 BN/R	10 S/R	5R
6T	36 BK/BL	37 BK/O	6T
6R	11 BL/BK	12 O/BK	6R
7T	38 BK/G	39 BK/BN	7T
7R	13 G/BK	14 BN/BK	7R
8T	40 BK/S	41 Y/BL	8T
8R	15 S/BK	16 BL/Y	8R
9T	42 Y/O	43 Y/G	9T
9R	17 O/Y	18 G/Y	9R
10T	44 Y/BN	45 Y/S	10T
10R	19 BN/Y	20 S/Y	10R
11T	46 V/BL	47 V/O	11T
11R	21 BL/V	22 O/V	11R
12T	48 V/G	49 V/BN	12T
12R	23 G/V	24 BN/V	12R
		50 V/S	T
		25 S/V	R

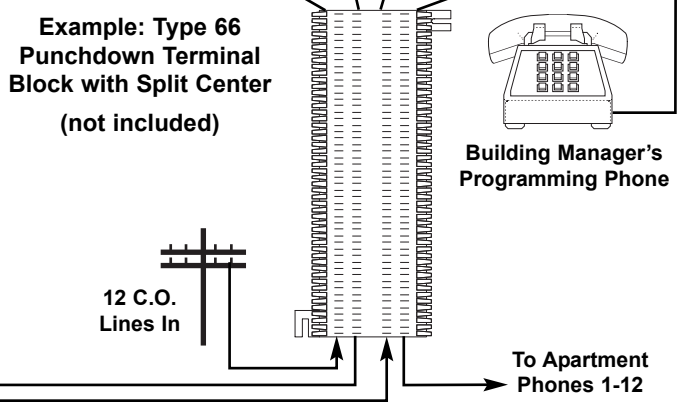

**Important:** Interconnect all modules coming OUT of the last slave module IN to the next, continuing from module to module on up to the Master module using the supplied modular cords. After wiring is complete, power up the last slave module first, continuing forward to the master module.

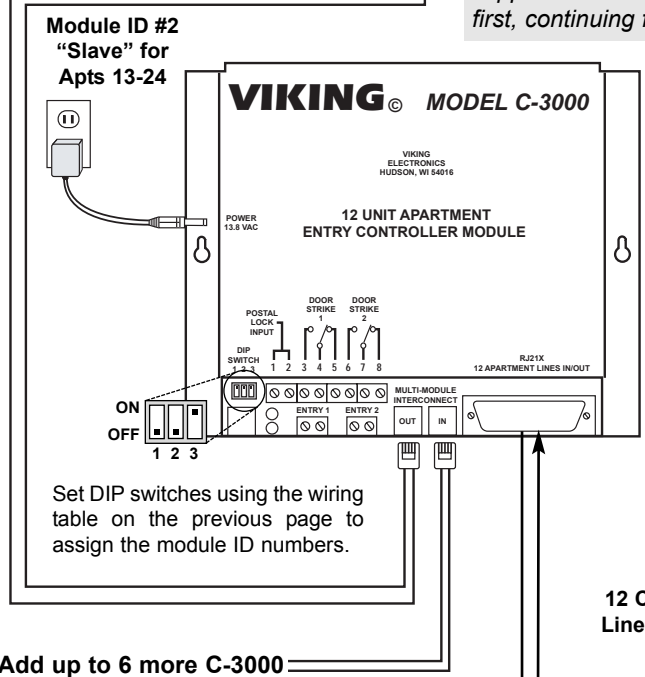

Bridged		Bridged	
Row 1 C.O. Lines	Row 2 C-3000	Row 3 C-3000	Row 4 Apt Phns
13T	26 W/BL	27 W/O	13T
13R	1 BL/W	2 O/W	13R
14T	28 W/G	29 W/BN	14T
14R	3 G/W	4 BN/W	14R
15T	30 W/S	31 R/BL	15T
15R	5 S/W	6 BL/R	15R
16T	32 R/O	33 R/G	16T
16R	7 O/R	8 G/R	16R
17T	34 R/BN	35 R/S	17T
17R	9 BN/R	10 S/R	17R
18T	36 BK/BL	37 BK/O	18T
18R	11 BL/BK	12 O/BK	18R
19T	38 BK/G	39 BK/BN	19T
19R	13 G/BK	14 BN/BK	19R
20T	40 BK/S	41 Y/BL	20T
20R	15 S/BK	16 BL/Y	20R
21T	42 Y/O	43 Y/G	21T
21R	17 O/Y	18 G/Y	21R
22T	44 Y/BN	45 Y/S	22T
22R	19 BN/Y	20 S/Y	22R
23T	46 V/BL	47 V/O	23T
23R	21 BL/V	22 O/V	23R
24T	48 V/G	49 V/BN	24T
24R	23 G/V	24 BN/V	24R

Add up to 6 more C-3000 Control Modules for a total of 96 apartments.

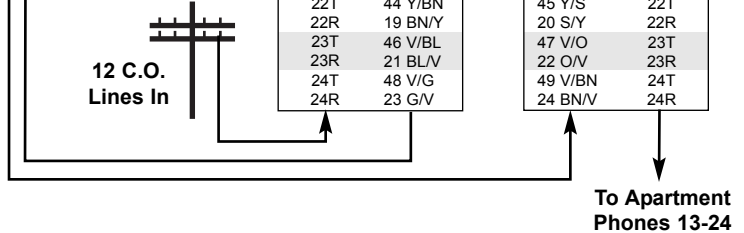

## F. Wiring with Modems (including DSL Lines)

The **C-3000** may be wired with this alternate wiring scheme which allows tenants to talk to their visitors without disrupting their C.O. modem transmissions, or losing DSL carrier signals. It requires two pair runs and RJ-14 jacks for each apartment. In this scheme, the modem will be connected to the Y/BK pair of the RJ-14 which is wired ahead of the **C-3000**, directly to the C.O. line. Use a 2 line splitter to connect the modem to the Y/BK pair. Wiring in this manner for all apartments assures a smooth transition as tenants add modems and DSL service in the future.

### 1. Concept

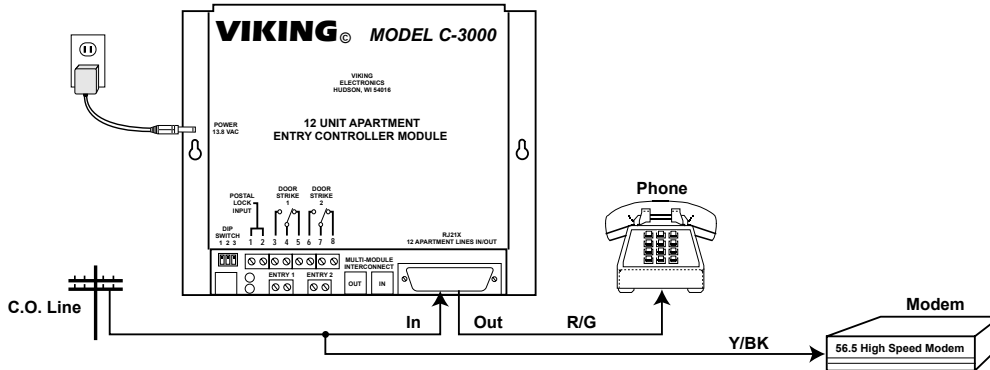

### 2. Detailed Example

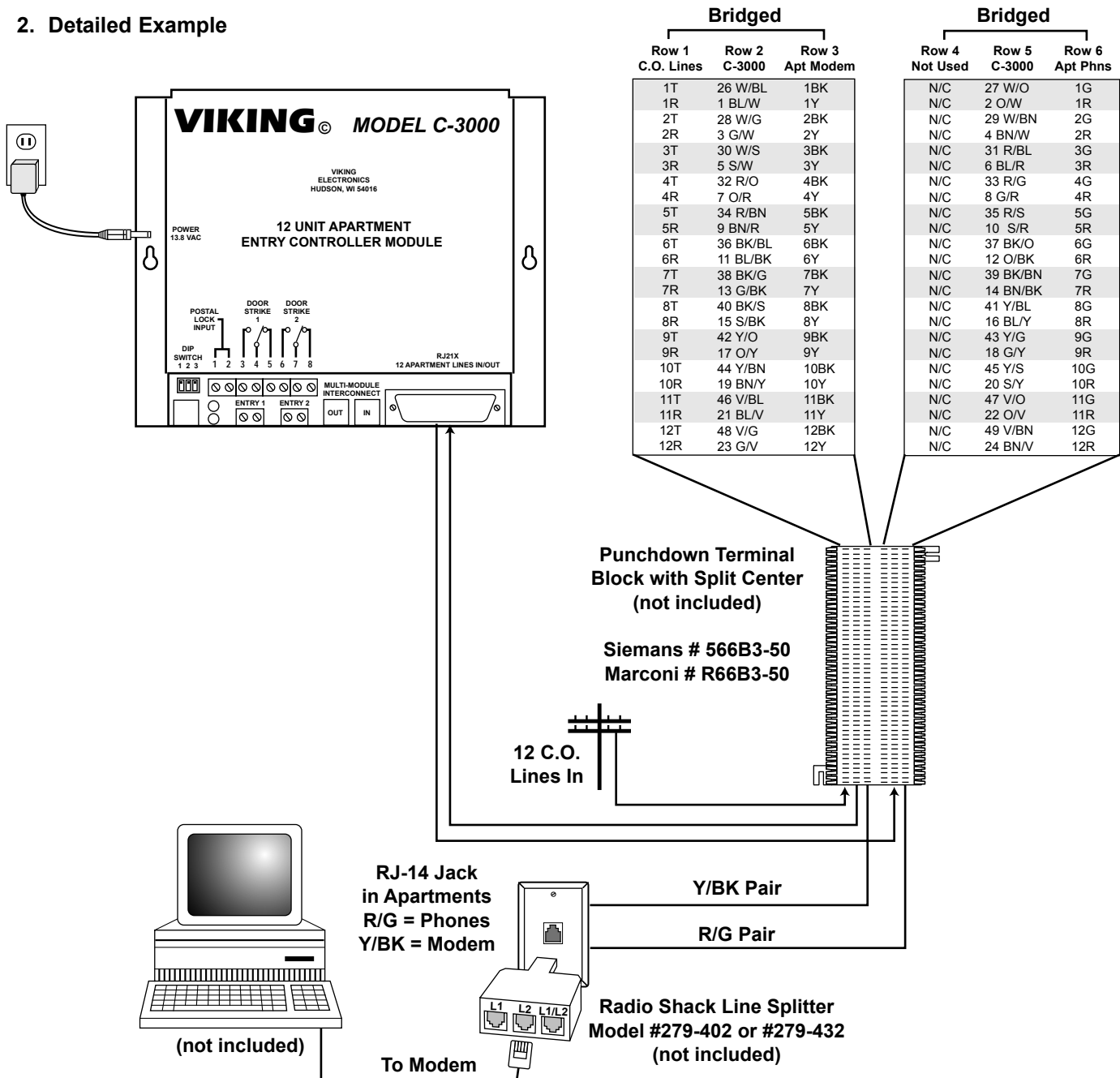

## G. Door Strike Relay Wiring

Use the relay contacts of the Master module to activate door strikes, magnetic locks, and gate controls.

Normally closed, normally open and common contacts are provided for both entry locations.

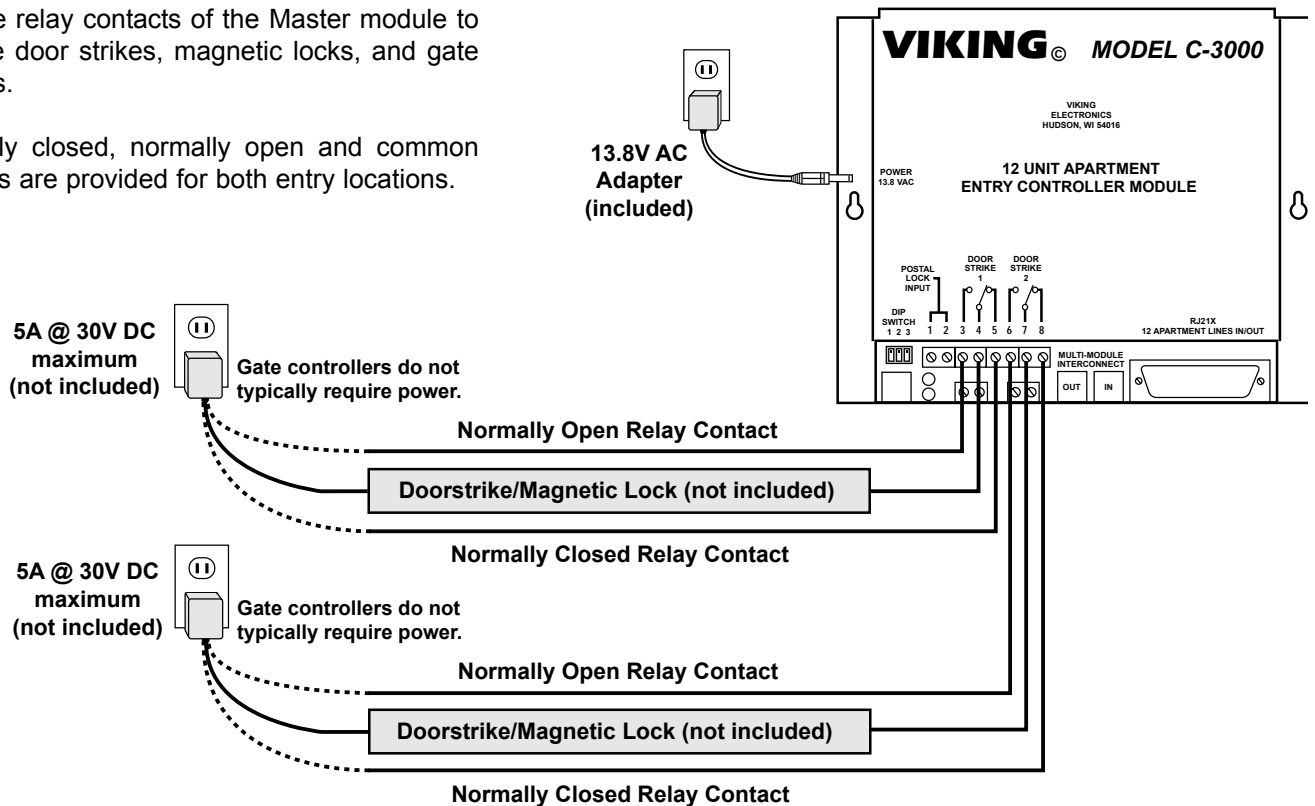

## Programming

### A. Definitions

**Program Phone:** A single line telephone or buttset connected to the Program Phone port (RJ-11) of a **C-3000** module.

**Building Manager's Programming Phone:** A single line telephone or buttset connected to pins 25/50 so that the Building Manager may easily change keyless entry codes, without the necessity of travelling to the **C-3000** system.

**Tenant Keyless Entry code:** A secret four to six-digit code assigned to a tenant, which is used to gain access to the building through the **C-3000** system. Keyless entry codes are programmed into memory positions **#01-#96**. There are no factory default settings for these values, nor is it a requirement that they be set.

**Master Keyless Entry Code:** A single, secret, four to six-digit code, which is normally not assigned to a tenant, but may be made known to the building manager, maintenance or security personnel. The Master keyless entry code is programmed into memory position **#00**. There is no factory default setting for this value, nor is there a requirement that it be set.

**Relay Activation Time:** The period of time (in seconds) for which a **C-3000** door strike relay will remain activated, after having been given an activation code. This value is factory preset to (5) seconds.

**Relay Activation Code:** The one-digit code entered on a tenant's touch-tone telephone keypad, which will activate a door strike relay to allow a visitor access to the building. This code is factory preset to "6".

**Maximum Call Time:** The maximum time (in minutes) allowed for a single conversation between a visitor at the door phone and a tenant. If this time is exceeded, both parties will be disconnected. This value is factory preset to (2) minutes.

**Maximum Ring Count:** The maximum number of times the **C-3000** system will ring any tenant's telephone, after being activated by a visitor at the door phone. This value is factory preset to (7) rings.

**Number of Modules:** The sum total of **C-3000** modules in the **C-3000** system. This value is factory preset to (1).

## B. Quick Programming Guide

Master Module Set Up	Enter Digits	- then -	Memory Location
Number of modules (1-8, factory set to 1) .....	<b>1 digit</b>	<b>+</b>	<b>##8</b>
Master keyless entry code (4-6 digits, no digits disables) .....	<b>4-6 digits</b>	<b>+</b>	<b>#00</b>
Tenants keyless entry codes (4-6 digits, no digits disables) .....	<b>4-6 digits</b>	<b>+</b>	<b>#01 - #96</b>
Clear all keyless entry codes and set all programming features to factory settings .....			<b>###</b>
<b>Slave and Master Module Set Up</b>			
Relay activation time (0-9, factory set to 5 sec, 0=.5 sec) .....	<b>1 digit</b>	<b>+</b>	<b>##3</b>
Relay activation code (factory set to 6) (cannot be a # or a *) (no digit=disable) .....	<b>1 digit</b>	<b>+</b>	<b>##4</b>
Maximum entry phone time (0-9, factory set to 2 min, 0=disabled) .....	<b>1 digit</b>	<b>+</b>	<b>##6</b>
Maximum ring count (0-9, factory set to 7, 0=10) .....	<b>1 digit</b>	<b>+</b>	<b>##7</b>

## C. Master C-3000 Module Setup

The following setup procedures are performed only on the Master module (ID #1) in the **C-3000** system. Come off-hook with the Program Phone on the Master module, and program the following settings.

### 1. Set Number of Modules

(1 digit, 1-8) + **##8** **Example:** If the **C-3000** system will consist of (4) modules, you would come off hook with the programming phone and enter "**4##8**." Two beeps will confirm a valid entry, three beeps will signify an error. This value is factory preset to (1).

### 2. Set Master Keyless Entry Code (optional)

(4-6 digits, 0-9) + **#00** -or- **#00** alone to clear this position **Example:** To set the Master Keyless entry code to "**052069**" you would come off-hook with the Program Phone and enter "**052069#00**." Entering "**#00**" without any leading digits will clear this position. Two beeps will confirm a valid entry, three beeps will signify an error.

### 3. Set Tenant Keyless Entry Codes (optional)

(4-6 digits, 0-9) + **#01-#96** -or- **#01-#96** alone to clear that position **Example:** To set the Tenant Keyless Entry code for apartment "**24**" to "**052069**" you would come off-hook with the Program Phone and enter "**052069#24**." Entering "**#01**" through "**#96**" without any leading digits will clear the respective position. Two beeps will confirm a valid entry, three beeps will signify an error.

### 4. Clear All Keyless Entry Code Positions and Set Programming Features to Default (optional)

**###** **Example:** To clear all Keyless Entry code positions in the entire **C-3000** system and return all programming settings back to factory default, enter "**###**". Two beeps will confirm a valid entry, three beeps will signify an error.

**Note:** Be **EXTREMELY** careful with the use of this feature, as it will immediately erase **ALL** keyless entry codes in the system, with no possibility for recovery. It is suggested that this feature be exercised when installing a new **C-3000** system, before any other programming is performed.

## D. General C-3000 System setup

The following procedures are to be performed on each module in the **C-3000** system, one module at a time. Note that while each module needs to be programmed separately, it is standard practice to make all of the following settings identical, for all modules. All four system setup programmable features are pre-programmed to factory defaults. If these settings are acceptable, then there is no need for additional programming.

### 1. Relay Activation Time (.5 - 9 seconds: factory default = 5 seconds)

(1 digit, 0-9) + **##3** ("1"=1 second, "0"=.5 second) **Example:** If you wish to set the door strike relay to activate for 8 seconds, you would come off-hook on the Program Phone and enter "**8##3**". Two beeps will confirm a valid entry, three beeps will signify an error. Repeat this process for each module.

### 2. Relay Activation Code (factory default = 6)

(1 digit, 0-9) + **##4** **Example:** If you wish to set the door strike relay to activate with the code "0", come off-hook with the Program Phone and enter "**0##4**". Two beeps will confirm a valid entry, three beeps will signify an error. Repeat this procedure for each module.

### 3. Maximum Entry Phone Time (1-9 minutes: factory default = 2 minutes)

(1 digit, 0-9) + ##6 ("0"=disabled) **Example:** If you wish to set the Maximum Entry Phone time limit to 3 minutes, come off-hook with the Program Phone and enter "3##6". Entering "0##6" will disable the time limit. Two beeps will confirm a valid entry, three beeps will signify an error. Repeat this procedure for each module.

### 4. Maximum Ring Count (1-10 rings: factory default = 7 rings)

(1 digit, 0-9) + ##7 ("0"= 10 rings) **Example:** If you to set the Maximum Ring Count to 8, come off-hook with the Program Phone and enter "8##7". Two beeps will confirm a valid entry, three beeps will signify an error. Repeat this procedure for each module.

## Operation

---

### A. Receiving a Visitor

A visitor arrives, takes the entry phone off-hook and dials a one or two-digit code (1-96), which corresponds to an individual tenant's apartment (see **Wiring Table** in **Installation** section **D**). The telephone(s) in the tenant's apartment then begin to ring in a special "double-ring" cadence, notifying the tenant that they have a visitor at the door. The tenant may then answer the call from any phone, and converse normally with the visitor. If the tenant's phone is already in use, the tenant receives a "call waiting" type tone, notifying them of the visitor's call. A hookswitch flash from the tenant's phone will put the current call on hold, and answer the visitor's call. A second hookswitch flash from the tenant's phone will disconnect the visitor's call and return the tenant to the original call, without allowing the visitor access to the building. Note that when either of the two entry phones are in use, the other entry phone is disabled for the duration of the call.

### B. Allowing a Visitor Entry

After communicating with a visitor at the door, the tenant can allow the visitor access to the building by entering a programmable code on the tenant's touch-tone telephone. The factory default relay activation code is "6". Upon entering this code, both parties will hear a brief buzzing tone as they are disconnected from the telephones, and the door strike relay operates giving the visitor access to the building. If the tenant had a call in progress, the tenant will also be automatically returned to the original call. If the visitor attempts to enter the relay entry code themselves, the **C-3000** system detects this and automatically disconnects both parties, without activating the doorstrike relay.

### C. Keyless Entry

Each tenant can be assigned a unique four to six-digit entry code, which may be used to gain access to the building without their key. In addition to the 96 tenant Keyless Entry codes, there is also one additional "Master" keyless entry code which may be used by anyone to which it is known. To access the Keyless Entry feature, the tenant takes an entry phone off-hook and enters "#", plus their keyless entry code. The doorstrike relay will then operate to allow the tenant access to the building. Note that it is not a requirement to set or use the **C-3000** keyless entry feature.

### D. Changing Keyless Entry Codes or Programming Features

From the Building Manager's Phone or the "Program Phone" port, all programming, including codes, can be performed. To change a keyless entry code, the Building Manager picks up the Building Manager's Programming phone, (if both entry phones are idle, two beeps will be heard to confirm that the **C-3000** system is ready for programming) and dials: **(New 4-6 digit entry code) + "#" + (00-96)**

For example, to set the Keyless Entry code for apartment 24 to "052069", the Building Manager would enter "052069#24" and then hang up, unless additional codes need to be changed. Two more beeps from the Building Manager's programming phone confirm a valid entry, three beeps will signify an error. See the "Programming" section for full details on the procedure for changing keyless entry codes. **Note:** *Both entry phones are disabled during programming.*

### E. Postal Lock Feature (Authorized Persons Only)

This feature is provided to allow an authorized person, such as a Postal Service worker to gain access to the building using a special key lock switch dedicated to this purpose. Keying the Postal Lock (momentary contact closure) will activate door strike 1 contacts for about 5 seconds.

# Door Entry Phones



**AES-2000S**  
Surface Mount

The **AES-2000** Accessible Entry System provides both audio and visual instructional assistance for those with varying disabilities.

Once two-way communication has been established, the tenant can activate a remote door strike by entering an authenticated Touch Tone command. The **AES-2000** will also support keyless entry at the door via its built-in keypad.

The unit is available in both flush and surface mount enclosures and features a highly vandal resistant housing. For more information on the **AES-2000**, retrieve **Fax Back Document 202**.



**K-1900-8** shown  
with **VE-5x10**

The **K-1700-3** provides a tough and attractive handsfree phone for apartment and door entry applications. The **K-1700-3** comes complete with a standard, flush mount, rough-in box. In addition, an optional weather resistant, surface mount box is available (right). For more information on the **K-1700-3**, retrieve **Fax Back Document 157**.



**K-1700-3** shown  
with **VE-6x7**

The **K-1900-8** housing consists of a heavy gauge stainless steel panel, a metal Touch Tone keypad, an armored cable, a heavy duty handset, and an all metal cradle. The **K-1900-8** is designed to be flush mounted but may also be surface mounted with an optional **VE-5x10** surface mount box. For more information on the **K-1900-8**, retrieve **Fax Back Document 362**.

**Note to Building Managers:** Please make copies of this form, fill them out and distribute to your tenants.

## Entry System Users Guide

**Tenant Name:** \_\_\_\_\_

**Tenant Unit #:** \_\_\_\_\_

**Tenant Phone #:** \_\_\_\_\_

### A. Receiving a Visitor

Upon arrival, a visitor dials the code \_\_\_\_\_ found on the directory of your apartment. Your telephone(s) then begin to ring in a special double-ring cadence, notifying you that you have a visitor at the door. You may then answer the call from any phone, and converse normally with the visitor. If your phone is already in use, you receive a "call-waiting" type tone, notifying you of the visitor's call. A hookswitch flash (a quick momentary hang-up of your phone) will put the current call on hold, and answer the visitor's call. A second hookswitch flash from your phone will disconnect the visitor's call and return you to the original call without allowing the visitor access to the building.

### B. Allowing a Visitor Entry

After communicating with a visitor at the door, you can allow the visitor access to the building by entering a \_\_\_\_\_ on your Touch Tone telephone. Upon entering this code, both parties will hear a brief buzzing tone while the visitor is allowed access to the building. If you were on a call, you will be automatically returned to the original call.

### C. Keyless Entry

Each tenant can be assigned a unique four to six-digit entry code, which may be used to gain access to the building without their key. To use the Keyless Entry feature, push the "Call" button or take the entry phone off-hook and enter \_\_\_\_\_.

**Product Support Line...715.386.8666**

**Fax Back Line...715.386.4345**

Due to the dynamic nature of the product design, the information contained in this document is subject to change without notice. Viking Electronics, and its affiliates and/or subsidiaries assume no responsibility for errors and omissions contained in this information. Revisions of this document or new editions of it may be issued to incorporate such changes.