

Power Failure Bypass System

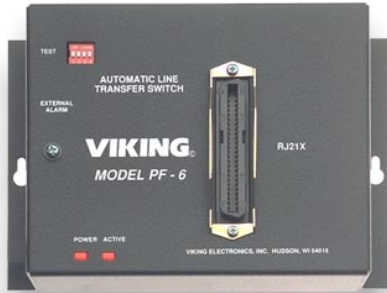

With the **PF-6A**, you will continue to receive your calls, during phone system and power outages. The **PF-6A** bypass unit connects 6 preassigned single line station phones directly to the C.O. trunks you have assigned. A built in ground start converter permits outbound calls from standard phones.

When the system is restored, you will not lose calls. Viking's **PF-6A** bypass unit will reconnect phones to their station circuits after they become idle.

The **PF-6A** can be configured to operate when power is lost or from an opening/closing of an alarm contact or manual closure.

The **PF-6A** can also be used to convert six incoming ground start lines to loop start lines. This accommodates installation of telephony equipment requiring loop start lines (i.e: key systems, call sequencers, answering machines, voice mail, etc.).

<http://www.VikingElectronics.com>

[E-mail...Sales@VikingElectronics.com](mailto:Sales@VikingElectronics.com)

Features

- Transfers six C.O. trunks directly to the designated analog station phones
- Stackable to increase capacity
- Allows you to receive calls as well as make calls during power or system failure
- Compatible with loop start lines or 48V ground start lines
- Automatic ground start converter eliminates "ground start buttons"
- Power restoration will not interrupt calls in progress
- Operates on power failure or normally open - normally closed alarm contacts

Applications

- Prevents busy signals or unanswered calls during power and system failures
- Converts ground start lines to standard loop start lines

Sales...(715) 386 - 8861

Made in the U.S.A.

Specifications

Power: 120 V AC/13.8V AC 1.25A, UL listed adapter provided or 24-48V DC, 100mA
Dimensions: 187mm x 127mm x 45mm (7.35" x 5" x 1.75")
Shipping Weight: .91 kg (2 lbs)
Environmental: 0°C to 32°C (32°F to 90°F) with 5% to 95% non-condensing humidity
Connections: (1) RJ21X, (1) RJ11

Installation

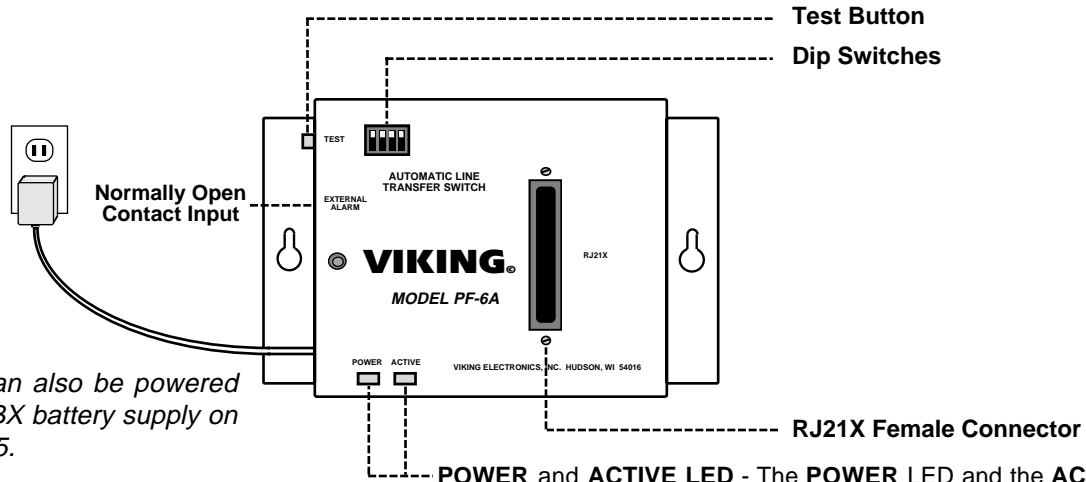

Note: The unit can also be powered by 24-48V DC PABX battery supply on terminals 50 and 25.

POWER and ACTIVE LED - The **POWER** LED and the **ACTIVE** LED will be lit when the **PF-6A** is in the normal operating mode. The **ACTIVE** LED will go out and the **POWER** LED will stay lit when the test button is pressed.

Important: This unit is not protected against damage from power line surges. A surge protector is recommended if operated on 120V AC.

A. Power Fail Bypass Unit

It is recommended that the first six C.O. lines be interfaced with the **PF-6A** as shown in the chart to the right.

If your system has an alarm contact or manual transfer switch, you must connect it to the red and green wires of the modular jack labeled **EXTERNAL ALARM** on the left side of the **PF-6A**. This must be a normally open maintained contact closure. If normally closed alarm contacts are used, wire them to break the power to the **PF-6A** when they open.

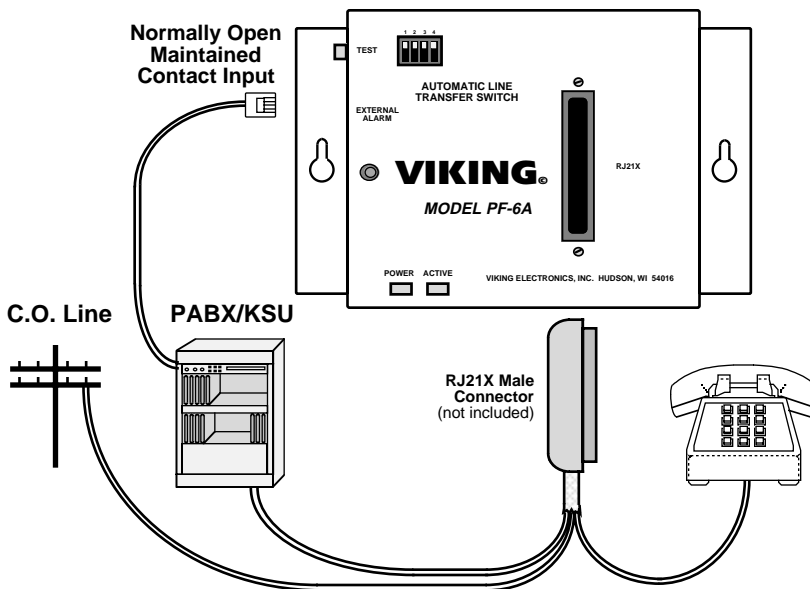

Note: Loop start and ground start CO lines may be combined on the **PF-6A** (see **Programming**). When ground start lines are used, pin 50 (V/S) must be connected to a good earth ground.

Circuit	Trunk/station	Line	Pins	Color
Circuit 1	Trunk 1 - IN	T1T-IN T1R-IN	26 1	W/BL BL/W
	Trunk 1 - OUT	T1T-OUT T1R-OUT	27 2	W/O O/W
	Station 1 - IN	S1T-IN S1R-IN	28 3	W/G G/W
	Station 1 - OUT	S1T-OUT S1R-OUT	29 4	W/BN BN/W
Circuit 2	Trunk 2 - IN	T2T-IN T2R-IN	30 5	W/S S/W
	Trunk 2 - OUT	T2T-OUT T2R-OUT	31 6	R/BL BL/R
	Station 2 - IN	S2T-IN S2R-IN	32 7	R/O O/R
	Station 2 - OUT	S2T-OUT S2R-OUT	33 8	R/G G/R
Circuit 3	Trunk 3 - IN	T3T-IN T3R-IN	34 9	R/BN BN/R
	Trunk 3 - OUT	T3T-OUT T3R-OUT	35 10	R/S S/R
	Station 3 - IN	S3T-IN S3R-IN	36 11	BK/BL BL/BK
	Station 3 - OUT	S3T-OUT S3R-OUT	37 12	BK/O O/BK
Circuit 4	Trunk 4 - IN	T4T-IN T4R-IN	38 13	BK/G G/BK
	Trunk 4 - OUT	T4T-OUT T4R-OUT	39 14	BK/BN BN/BK
	Station 4 - IN	S4T-IN S4R-IN	40 15	BK/S S/BK
	Station 4 - OUT	S4T-OUT S4R-OUT	41 16	Y/BL BL/Y
Circuit 5	Trunk 5 - IN	T5T-IN T5R-IN	42 17	Y/O O/Y
	Trunk 5 - OUT	T5T-OUT T5R-OUT	43 18	Y/GN GN/Y
	Station 5 - IN	S5T-IN S5R-IN	44 19	Y/BN BN/Y
	Station 5 - OUT	S5T-OUT S5R-OUT	45 20	Y/S S/Y
Circuit 6	Trunk 6 - IN	T6T-IN T6R-IN	46 21	V/BL BL/V
	Trunk 6 - OUT	T6T-OUT T6R-OUT	47 22	V/O O/V
	Station 6 - IN	S6T-IN S6R-IN	48 23	V/GN GN/V
	Station 6 - OUT	S6T-OUT S6R-OUT	49 24	V/BN BN/V

Station or trunk control line	GND -24/48V	50 25	V/S S/V

B. Ground to Loop Start Converter

The ground start converter in the **PF-6A** will only work properly when connected in series with the ground start trunks as shown below.

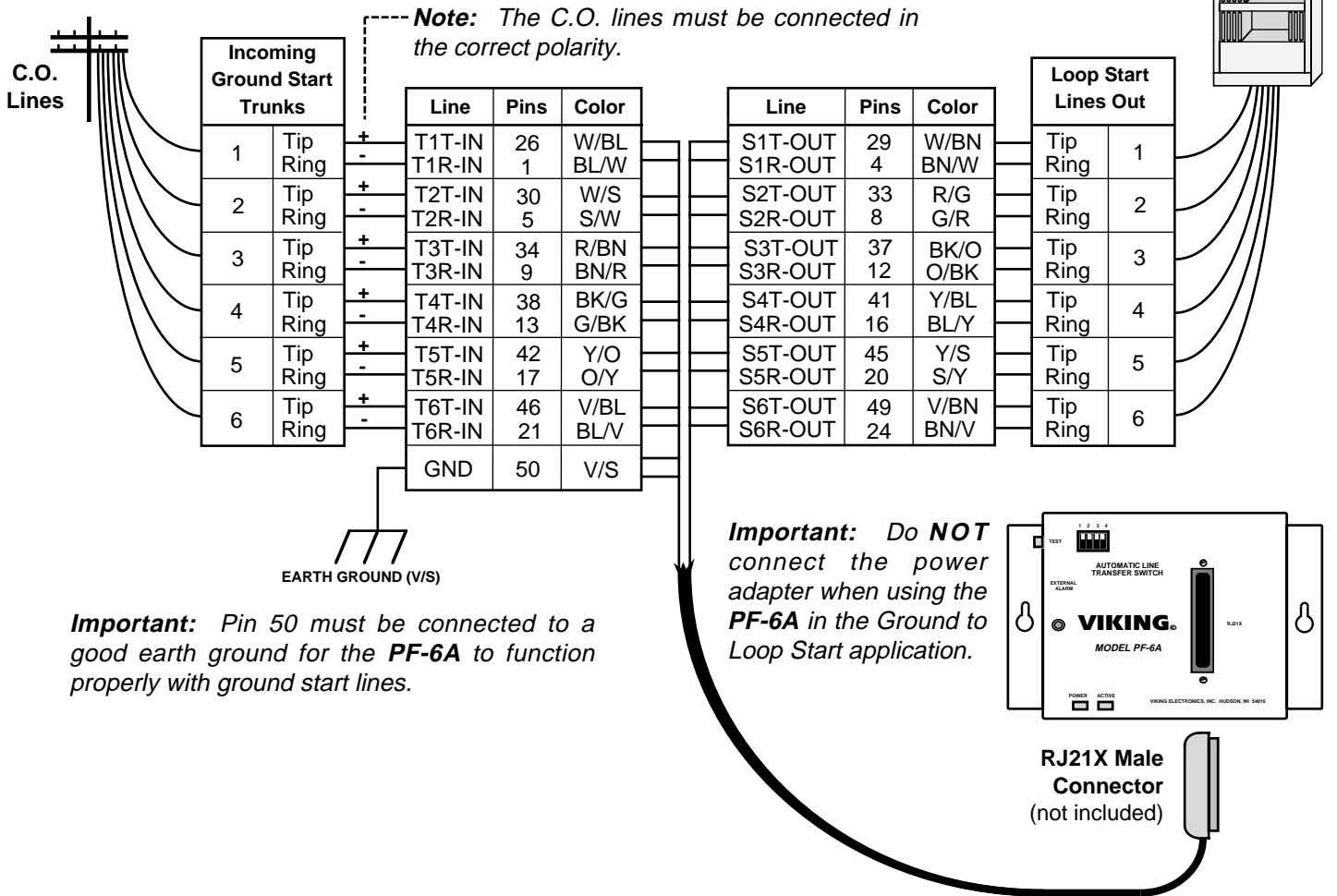

Programming

The DIP switches may be used to program loop start or ground start lines. You may also use DIP switch 1 to toggle between normal and bypass mode for testing purposes.

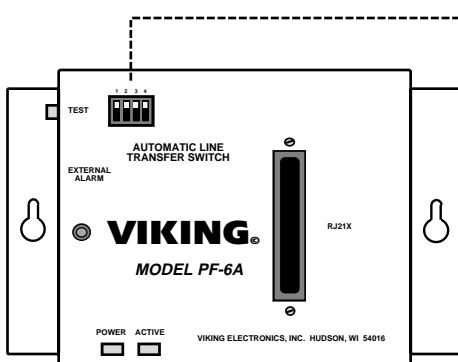

Dip Switch	ON/OFF	Description
1	OFF	Normal operation
	ON	Bypass mode for testing
2	OFF	Assigns lines 1, 2, 3 to loop start
	ON	Assigns lines 1, 2, 3 to ground start
3	OFF	Assigns lines 4, 5, 6 to loop start
	ON	Assigns lines 4, 5, 6 to ground start
4	OFF	Not used
	ON	Not used

Operation

A. Power Fail or System Fail Bypass

After installation is complete, test the **PF-6A** by doing one of the following:

1. Press and hold the TEST button
2. Move DIP switch 1 to the **ON** position
3. Disconnect power to the **PF-6A**
4. Provide a maintained normally open contact closure to the **EXTERNAL ALARM** input

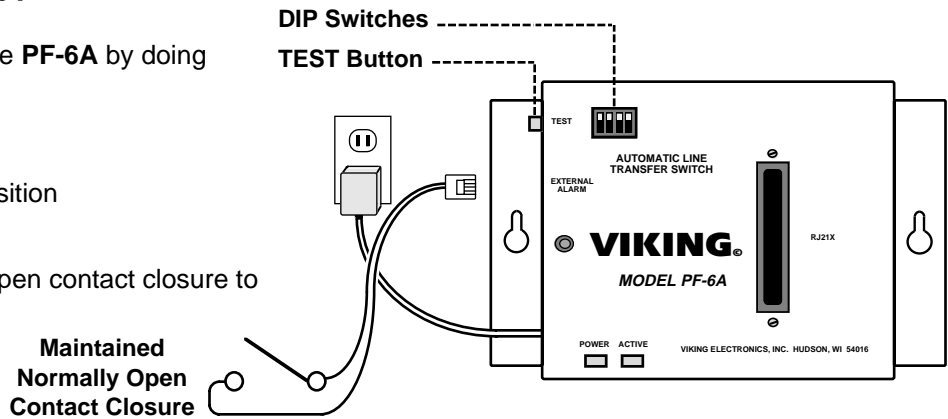

After installing and testing the **PF-6A**, instruct office personnel that in the event of the power failure or system failure that the six assigned telephones will be the only means to receive and place calls.

While the **PF-6A** is in normal operating mode, the six C.O. lines are connected to the trunk inputs and the six assigned station circuits are connected to their six telephones.

In the event of either a power failure or a major PABX alarm, the **PF-6A** will shift into the bypass mode. In this mode, the six C.O. trunks are instantly connected to the six analog telephones designated, bypassing the PABX/KSU.

Incoming calls will now ring directly to the telephones assigned to the six C.O. trunks. Outgoing calls may also be made from each telephone, even on ground start lines.

When power is restored or the major alarm is cleared, the **PF-6A** will automatically switch back to normal operation. Any C.O. trunk in use at this time will remain connected until the call is completed.

B. Ground to Loop Start Converter

The **PF-6A** can also be used as a ground start to loop start converter. This accommodates the installation of telephony equipment requiring loop start lines (ie; key systems, call sequencers, answering machines, voice mail systems, etc.), to ground start C.O. trunks. See **Installation** for proper wiring in this application.

In this application, the **PF-6A** will not pass disconnect supervision ("hang up" signals) to the loop start equipment. When a hang up occurs, the **PF-6A**'s ground start converter automatically "restarts" the line and dial tone is returned to the loop start equipment. The loop start equipment will not detect any disconnect, as this "restart" occurs immediately after the hang up. Typically this will cause the loop start equipment to **not** release the telephone line when a caller abandons. Nothing can be done about this situation, as the **PF-6A** can not distinguish the difference between this abandon condition and the loop start equipment going "off hook" to make an outgoing call.

Note: The **PF-6A** can **ONLY** be used to convert ground start lines to loop start. It can **NOT** convert loop start lines to ground start.

Product Support Line...(715) 386-8666

Fax Back Line...(715) 386-4345

Due to the dynamic nature of the product design, the information contained in this document is subject to change without notice. Viking Electronics, its affiliates and/or subsidiaries assume no responsibility for errors and/or omissions contained in this information. Revisions of this document or new editions of it may be issued to incorporate such changes.