

This manual is for reference and historical purposes, all rights reserved.

This page is copyright© by M. Butkus, NJ.

This page may not be sold or distributed without the expressed permission of the producer
I have no connection with any camera company

On-line camera manual library

This is the full text and images from the manual. This may take 3 full minutes for the PDF file to download.

If you find this manual useful, how about a donation of \$3 to: M. Butkus, 29 Lake Ave., High Bridge, NJ 08829-1701 and send your e-mail address so I can thank you. Most other places would charge you \$7.50 for a electronic copy or \$18.00 for a hard to read Xerox copy.

This will allow me to continue to buy new manuals and pay their shipping costs.

It'll make you feel better, won't it?

**If you use Pay Pal or wish to use your credit card,
click on the secure site on my main page.**

(9) PICTURE MODE

1

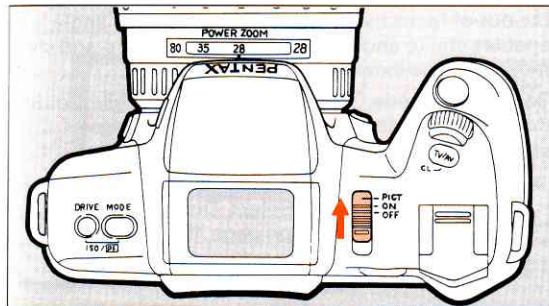

The Picture Mode has a total of 5 modes, including the fully-automatic Green Operation Mode, Portrait Program, Landscape Program, Action Program and Close-up Program modes, allowing you to use these highly advanced photographic techniques effortlessly. See "Green Operation Mode" on page 22.

2

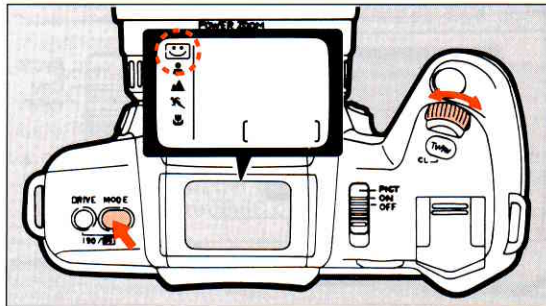

Procedure

1. Move the camera's Main Switch to [PICT].
2. To set the desired mode, turn the Select Dial while holding down the Mode Button.

To the left

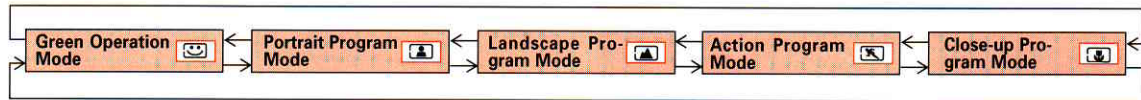

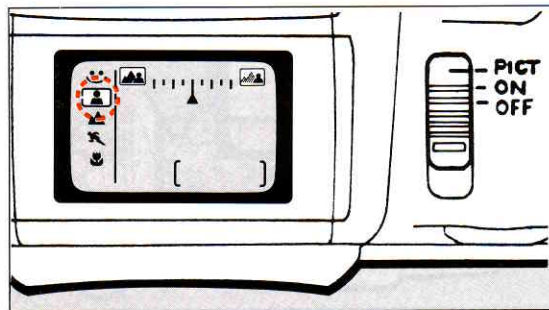

To the right

Portrait Program Mode []



This mode is excellent for taking a portrait. The telephoto lens produces a portrait in crisp focus against the out-of-focus background, while the wide angle lens enables you to shoot group portraits in sharp and clear focus with the extended depth-of-field.

To set this mode, turn the Select Dial while holding down the Mode Button until the rectangle [] superimposes on [].



- The in-focus range (depth-of-field) can be increased or reduced with the Select Dial as desired. See "Hyper Program-Shift" on page 40.

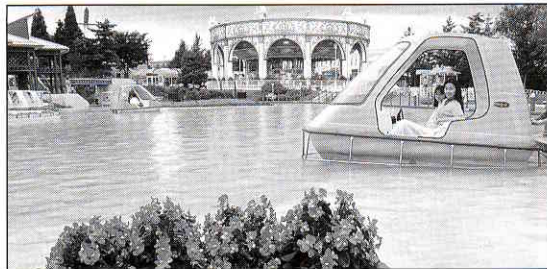
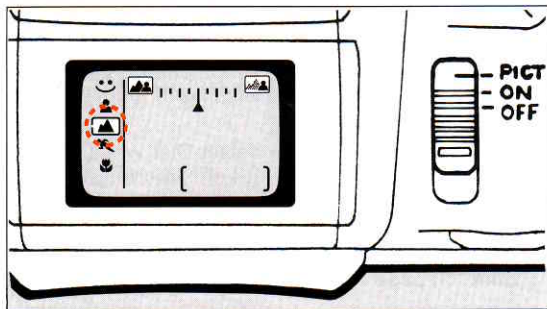

Landscape Program Mode []



This mode ensures that the foreground, middle and background are focused sharply throughout the image field, making it ideal for landscapes and scenic snapshots.



To set this mode, turn the Select Dial while holding down the Mode Button until the rectangle [] superimposes on [].

- The in-focus range (depth-of-field) can be increased or reduced with the Select Dial as you desire. See "Hyper Program-Shift" on page 40.

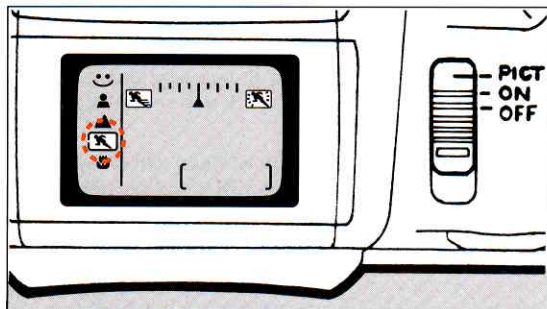
Action Program Mode []



This mode selects a faster shutter speed to capture a subject in motion. It freezes the action and prevents blurred images. This mode is especially convenient for active photography. It is also suitable for portraits with a blurred background, or for action photography while "panning" the subject when wishing to blur/streak the background.



To set this mode, turn the Select Dial while holding down the Mode Button until the rectangle [] superimposes on [].

- The image blur can be increased or reduced with the Select Dial as it suits you. See "Hyper Program-Shift" on page 40.

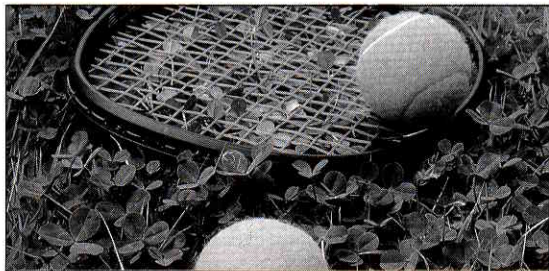
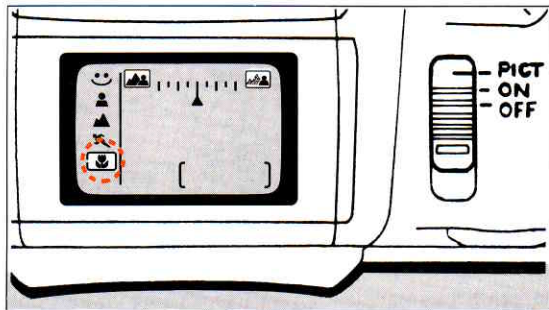
Close-up Program Mode []



This mode is extremely useful for close-up photography. It favors smaller apertures to maximize the depth of field, ensuring sharp focus of a close-up subject.

To set this mode, turn the Select Dial while holding down the Mode Button until the rectangle [] superimposes on [].

- The in-focus range (depth-of-field) can be increased or reduced with the Select Dial as you desire. See "Hyper Program-Shift" on page 40.

(1) HYPER PROGRAM-SHIFT

III. ADVANCED OPERATIONS

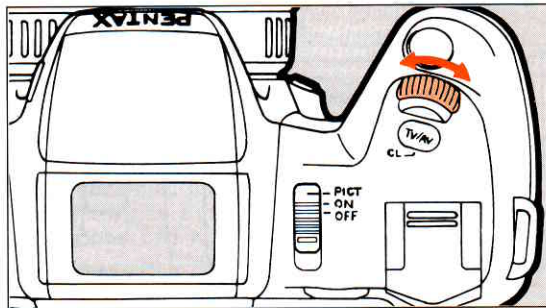

In each Picture Mode (except the Green Operation Mode), the in-focus range (depth of field) and the extent of image blur can be easily changed by turning the Select Dial, which allows you to create distinctive visual effects or alter the effects drastically. The shifted amount is confirmed by dots on the bar graph in the LCD panel.

- Hyper Program-Shift works effectively within the shutter speed/aperture combination coupling range for correct exposure control.
- Hyper Program-Shift is possible in the Programmed AE mode (See page 40.) However, the bar graph is not displayed in this case.
- Hyper Program-Shift is not canceled after the shutter is released.
- The learning function works when the Hyper Program-Shift is executed.
- Removing the lens resets the Hyper Program-Shift.

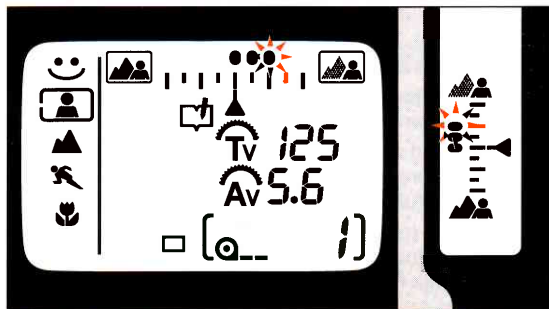

In Portrait Program, Landscape Program and Close-up Program Mode

To reduce the in-focus range, turn the Select Dial to the right. Dots will successively appear to the right on the LCD panel and to the top in the viewfinder, indicating the shift to a narrower in-focus range. To widen the in-focus range, turn the Select Dial to the left. Dots will successively appear to the left on the LCD panel and to the bottom in the viewfinder, indicating the shift to a wider in-focus range.

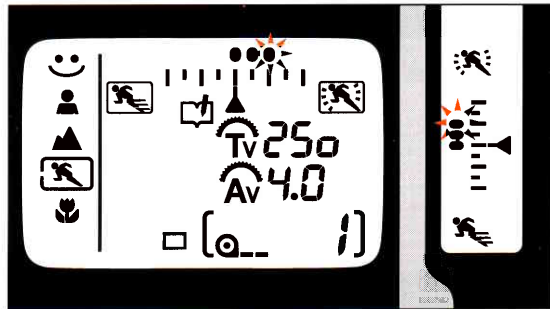

In Action Program Mode



Turning the Select Dial to the right reduces image blur. Dots will successively appear to the right on the LCD panel and to the top in the viewfinder, indicating the shift to a reduced image blur. To increase the image blur, turn the Select Dial to the left. Dots will successively appear to the left on the LCD panel and to the bottom in the viewfinder, indicating the shift to an increased image blur.

- The selection of Hyper Program-Shift is indicated with [^] above Tv and Av mark on the LCD panel and with a bar underneath an aperture and shutter speed in the viewfinder.
- To cancel the Hyper Program-Shift, depress the Tv/Av Button.
- If the selection of Hyper Program-Shift exceeds the range of the bar graph, all five dots to the selected shift side light up continuously.

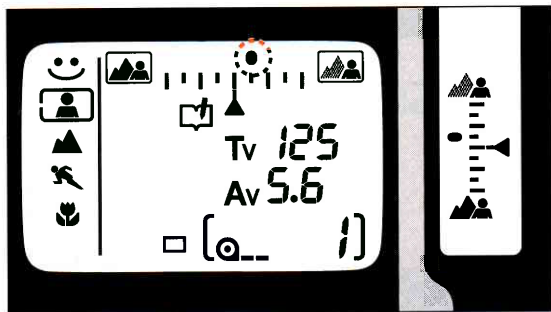
(2) LEARNING FUNCTION



If the exposure is shifted with the Hyper Program-Shift in the Picture Mode (except the Green Operation Mode), the learning function works and automatically shifts a shutter speed/aperture combination according to the shift you selected, making it easier to suit a photographer's personal taste. The amount of shift is indicated by the bar graph in the viewfinder and on the LCD panel as shown. If dots shift to the right on the LCD panel and to the top in the viewfinder, it indicates the shift to a narrower in-focus range or a reduced image blur. If dots shift to the left on the LCD panel and to the bottom in the viewfinder, it indicates the shift to a wider in-focus range or an increased image blur.

- Each time the shutter releases, [] blinks on the LCD panel, indicating that the learning function is being activated.
- This function does not work unless [] appears on the LCD panel.
- The shifted amount i.e. contents of learning function will be stored in memory even if the camera's Main Switch is turned OFF or the battery removed.
- In order to set this function with the retained memory and prevent the storage of a new memory, use Pentax Function No.4.
- This function can be canceled by Pentax Function No.5. See page 81 for details.
- The learning function works independently in each Picture Mode (except the Green Operation Mode).

(3) MANUAL FOCUSING

1

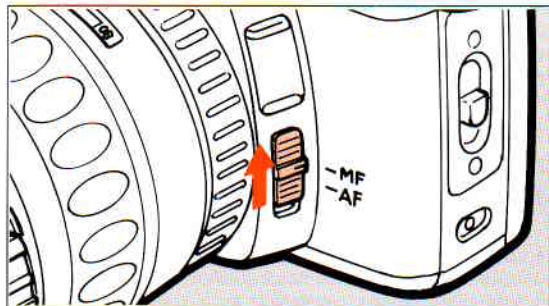

1) With a manual-focus lens

When mounting an existing KA- or K-mount lens with a maximum aperture of f/5.6 or larger (f/1.2 to f/5.6), use the manual focus mode to focus the lens with the aid of the in-focus indicator [] in the viewfinder.

How-To-Manual Focus

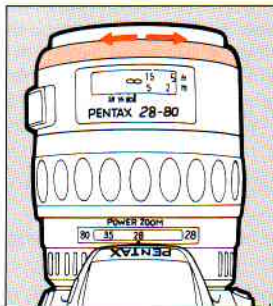

1. Set the focus mode switch to [**MF**].
2. While looking through the viewfinder, turn the focusing ring to the right or left while holding the shutter release button halfway down.
3. When the subject comes into focus, the in-focus indicator [] lights up in the viewfinder. Depress the shutter release button fully to take a photograph.

2

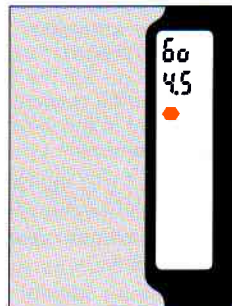

3



- When using a KAF- or KAF₂-mount lens in the manual focus mode (with the focus mode switch set to [**MF**]), focus the lens with the aid of the in-focus indicator [] in the viewfinder.
- If an old type screw-mount lens is combined with an optional "Mount Adapter K", the viewfinder's in-focus indicator [] cannot be used for focus confirmation.
- When the subject comes into focus, the in-focus indicator [] lights up in the viewfinder and an audible PCV signal is heard. The audible PCV signal can be canceled by selecting the silence mode using Pentax Function No.3. (See page 80.)

When the Autofocus Mode or the In-Focus Indication Is Unsuitable for Focusing

When the autofocus function or the viewfinder's in-focus indicator [] cannot be used for focus confirmation for the following reasons, focus on the subject in the manual focus mode with the aid of the matte field in the viewfinder as in the case with a non-AF SLR camera.

- a) The in-focus indicator blinks because the subject is difficult to autofocus.
- b) The maximum aperture of the lens in use is smaller than f/5.6.
- c) A Bellows 100mm f/4, Shift 28mm f/3.5 (shifted), or Reflex lens is in use.
- d) An old type screw-mount lens is fitted with an optional "Mount Adapter K".

How to Manual-Focus

1. Set the focus mode switch to [**MF**] .
2. While looking through the viewfinder, turn the focusing ring to the right or left until the image in the viewfinder is clearest. Then, depress the shutter release button fully to take a photo.

Using the Snap-in Focus Function

If a KA- or K-mount lens is used together with the optional "Cable Switch F" with the focus mode switch set at [**AF**] , "snap-in focus" is possible where the shutter is automatically released when a subject comes into focus.

1. Use a KA- or K-mount lens.
2. Set the focus mode switch to [**AF**] .
3. Focus at the point where you expect to capture the subject.
4. Using the optional "Cable Switch F", keep the trigger release button depressed so that the autofocus and metering systems stay active.
5. The camera releases the shutter automatically when the subject comes into focus at the point selected.

(4) HARD-TO-AUTOFOCUS SUBJECTS

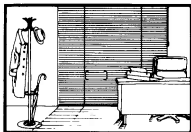
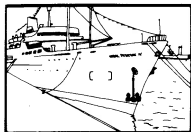

The autofocus system is highly precise, but not perfect. Some subjects may not focus as you wish. In such a case, use the focus-lock technique on a subject near the actual one and equidistant from the lens, or set the focus mode switch to **[MF]** and use the manual focus mode to focus the lens on the subject with the aid of the matte field in the viewfinder. Subjects which may fool the autofocus system include:

- Extremely low-contrast subjects such as a white wall in the AF frame
- Subjects which don't reflect much light in the AF frame
- Subjects which are moving too fast
- Subjects with horizontal lines or with finely complex or detailed patterns in the AF frame
- Multiple subjects in the foreground and background of the AF frame
- Subjects positioned against reflected light or strong backlight or with extremely bright backgrounds

Notes on accessories

The following conditions do not allow autofocusing or manual-focusing which uses the in-focus indicator in the viewfinder. Use the manual-focus mode to focus on the subject with the aid of a matte field surrounding the AF frame.

- When using special effect filters or "Magic Image Attachment" or "Stereo Adapters"
- When using an ordinary polarizing filter: a half mirror incorporated into the autofocus system reduces the effectiveness of the autofocus function when used in combination with an ordinary polarizing filter. Use a circular polarizing filter for autofocus operation.
- When using Extension Tubes or an Auto Bellows for close-up photography

Note on the SMC Pentax F SOFT 85mm f/2.8 lens

When shooting at a distance closer than approx. 1.5m, set the lens to a manual f-stop setting between f/2.8 and f/4.5. A smaller aperture (f/5.6 to f/32) may cause the autofocus system and the viewfinder's focus indicator to malfunction. To remedy this problem, temporarily set the lens to f/4.5. After focusing on the subject, lock focus, and set the lens to the required f-stop.

(5) SELECTING AN EXPOSURE MODE

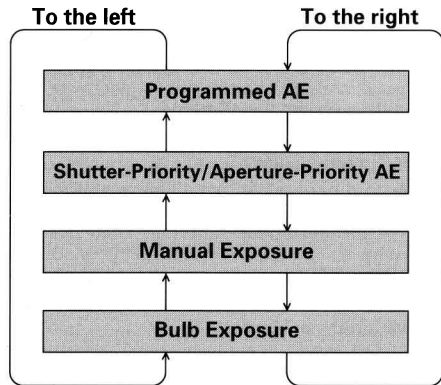

With the lens aperture ring at "A" (auto), moving the camera's Main Switch to [**ON**] (full-feature position) lets you select any of the available exposure modes other than the Picture Mode, without having to turn the aperture ring to a manual f-stop setting.

Switching the Exposure Mode

The Full-Feature mode provides a total of five exposure modes. The exposure mode switches as shown at left in accordance with the rotation of the Select Dial while holding down the Mode Button. See the respective pages for explanations on each exposure mode.

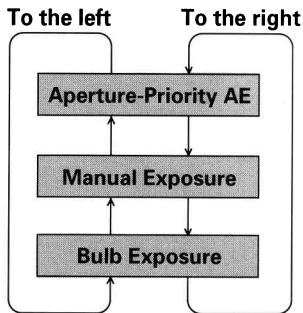

Turn the lens aperture ring from "A" (auto) to a manual f-stop setting when using accessories as below.

- Accessories such as the "Extension Tube Set" which do not allow the automatic diaphragm control for exposure.
- Old type flash units which do not allow the use of the "A" (auto) lens aperture.

Whether the Main Switch is set to [**ON**] or [**PICT**], with a manual f-stop setting (when the aperture ring is at a position other than "A" (auto)), any of the three exposure modes at left can be selected and the exposure mode switches in a similar manner as when using "A" (auto) lens aperture.

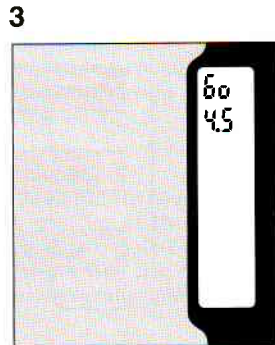
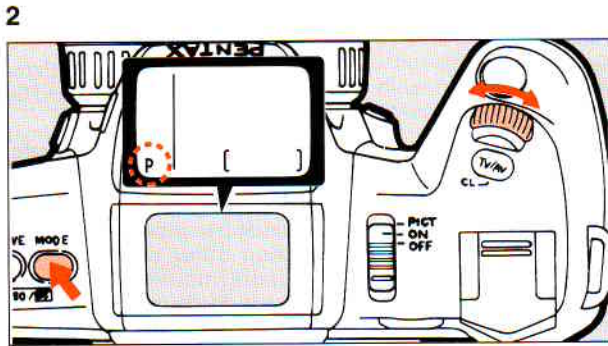
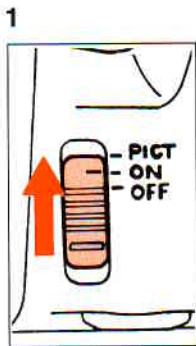

Programmed AE Mode

The camera selects the optimum combination of shutter speed and aperture automatically, making it easy to take a good photograph by just a depression of the shutter release button.

Turn the aperture ring to "A" (auto).

1. Move the Main Switch to [ON].
2. While holding down the Mode Button, turn the Select Dial until [P] is displayed on the LCD panel.
3. When the shutter release button is depressed halfway down, the shutter speed and aperture will be displayed in the viewfinder and on the LCD panel.

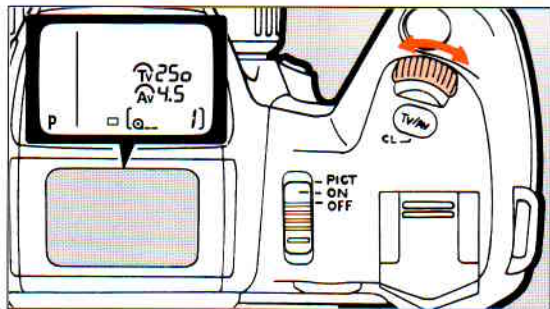

HYPER PROGRAM-SHIFT IN PROGRAMMED AE MODE

The Programmed AE mode features Hyper Program-Shift. Hyper Program-Shift lets you change the shutter speed/aperture combination while maintaining the same exposure. When the Select Dial is rotated to the right, the shutter speed shifts to a faster shutter speed setting while the aperture shifts to a larger aperture; when it is rotated to the left, the shutter speed shifts to a slower shutter speed setting while the aperture shifts to a smaller aperture.

- When the Hyper Program-Shift is executed, [] will light up above the selected shutter speed and aperture indications in the viewfinder and on the LCD panel, confirming that the Hyper Program-Shift is in use. The selection can be also confirmed by a bar underneath the selected shutter speed and aperture in the viewfinder.
- To cancel the Hyper Program-Shift, depress the Tv/Av Button.

*

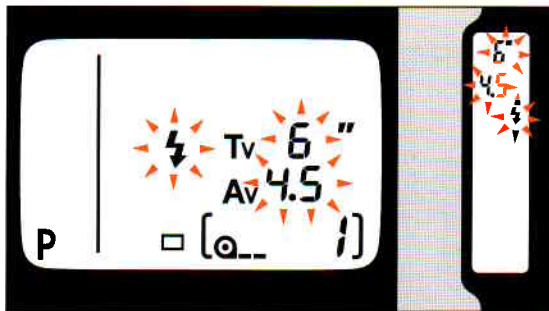

- Hyper Program-Shift works effectively within the shutter speed/aperture combination coupling range for correct exposure control.
- Hyper Program-Shift is possible in the Programmed AE Mode. However, the bar graph will not be displayed when the Hyper Program-Shift is executed in this mode.

* EXPOSURE WARNING

With a too bright or dark subject, the indicators will blink in the viewfinder and on the LCD panel as shown in the illustration to warn you. Use an ND filter if the subject is too bright and a flash if it is too dark.

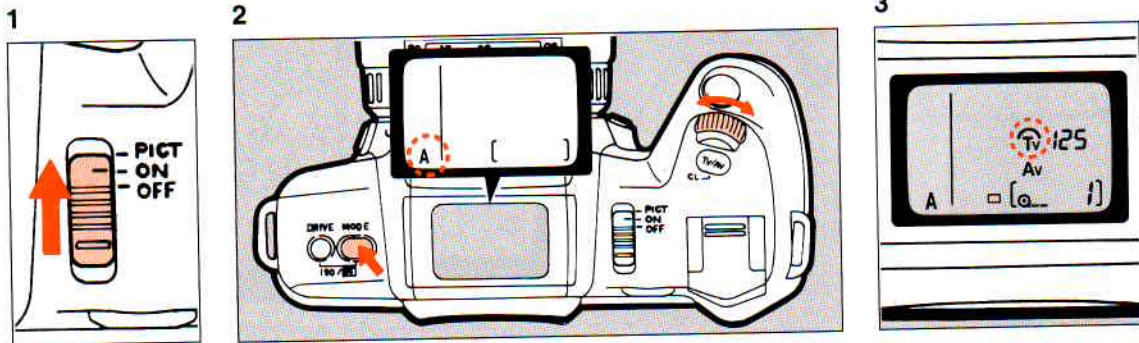

Shutter-Priority AE Mode

When the desired shutter speed is selected, the aperture is automatically set by the camera for a proper exposure according to the brightness of the subject. This mode is suitable for freezing the action with a fast shutter speed or capturing a flowing dynamic image with a slow shutter speed.

Turn the aperture ring to "A" (auto).

1. Move the camera's Main Switch to [ON].
2. While holding down the Mode Button, turn the Select Dial until [A] appears on the LCD panel.
3. Depress the Tv/Av Button so that [\curvearrowright] appears above Tv on the LCD panel indication.

4



5

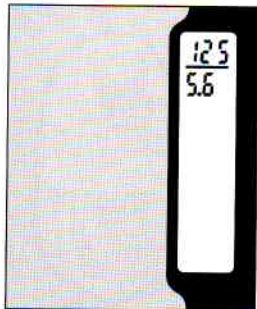

*

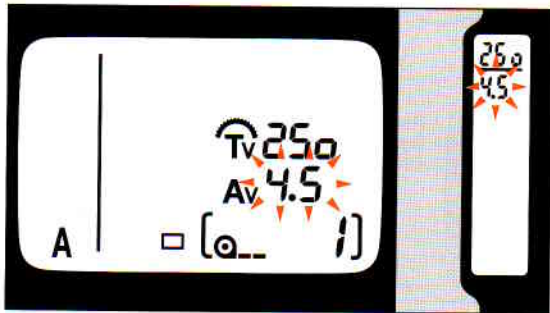

* EXPOSURE WARNING

If the subject is too bright or dark, the selected aperture will blink in the viewfinder and on the LCD panel as a warning as shown. When the subject is too bright, choose a faster shutter speed. If it is too dark, choose a slower shutter speed. When the aperture indication stops blinking, take a photograph. If both the selected shutter speed and aperture blink, it means that the exposure is out of metering range: use an ND filter if the subject is too bright and a flash if it is too dark.

4. Select the desired shutter speed with the Select Dial.
 - At this time a bar will appear underneath the selected shutter speed in the viewfinder indication.
 - When the Select Dial is rotated to the right, the shutter speed is switched to a faster speed; when it is rotated to the left, a shutter speed is switched to a slower speed.
5. When the shutter release button is depressed halfway down, the selected shutter speed and aperture will be displayed in the viewfinder and on the LCD panel.

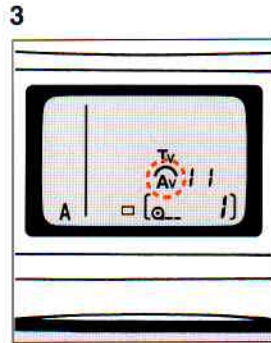
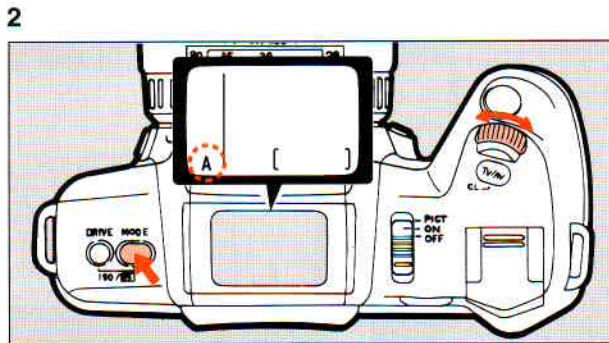
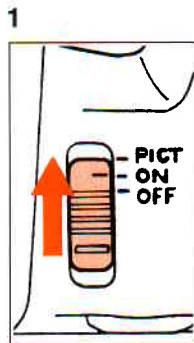

Aperture-Priority AE Mode

When the desired aperture is selected, an appropriate shutter speed is automatically set by the camera for a proper exposure. This mode is ideal for shooting landscapes with an increased depth of field, or a portrait against a blurred background.

Turn the aperture ring to "A" (auto).

1. Move the camera's Main Switch to [ON].
2. While holding down the Mode Button, turn the Select Dial until [A] appears on the LCD panel.
3. Depress the Tv/Av Button so that [\curvearrowright] appears above Av on the LCD panel.

4



5

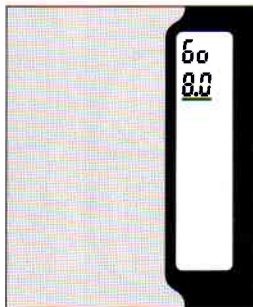

4. Select the desired aperture with the Select Dial.
 - At this time a bar will be displayed underneath the selected aperture in the viewfinder.
 - When the Select Dial is rotated to the right, the aperture is switched to a smaller aperture; when it is rotated to the left, the aperture is switched to a larger aperture.
5. When the shutter release button is depressed halfway down, a shutter speed and aperture will be displayed in the viewfinder and on the LCD panel.

*

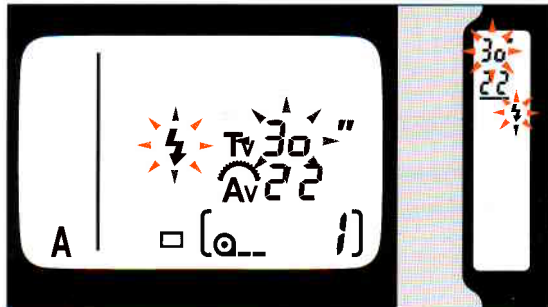

* EXPOSURE WARNING

If the subject is too bright or dark, the selected shutter speed will blink in the viewfinder and on the LCD panel as shown to alert you. When the subject is too bright, choose a smaller aperture; when it is too dark, choose a larger aperture. When the shutter speed indication stops blinking, take a photograph. If both the shutter speed and aperture blink, it means that the exposure is out of metering range: use an ND filter if the subject is too bright and a flash if it is too dark.

1

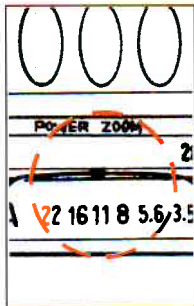

2

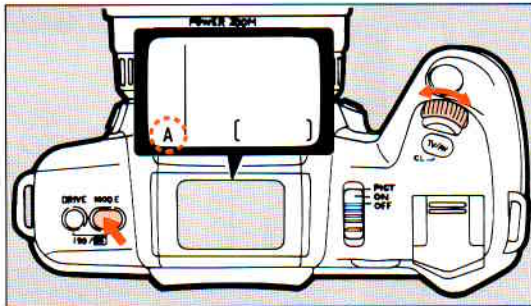

3

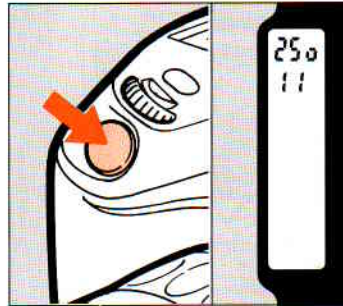

When Using a Manual F-Stop Setting (Move the camera's Main Switch to [ON] or [PICT] .)

With the aperture ring set at a manual f-stop setting, you can select an Aperture-Priority AE mode.

1. Turn the lens aperture ring to a position other than "A".
 2. While holding down the Mode Button, turn the Select Dial so that [A] appears on the LCD panel.
 3. When the shutter release button is depressed halfway down, a shutter speed and aperture will be displayed in the viewfinder and on the LCD panel.
- When the lens in use is an FA or F lens, the approximate aperture value will be displayed in the viewfinder and on

the LCD panel by half-depression of the shutter release button. With other lenses, no indication will appear.

- When a lens without the lens information contacts (lenses made before the Pentax M series) is used with the aperture selected by the lens aperture ring in the Aperture-Priority AE mode, the camera switches the metering system from Multi(6)-Segment to Center-Weighted.
- When using a Pentax A-series 50mm f/1.2 lens, set the lens aperture ring to A (auto).

*** EXPOSURE WARNING**

The exposure warning indication appears in a similar manner as when the lens aperture ring is set to "A" (auto). See page 53 for details.

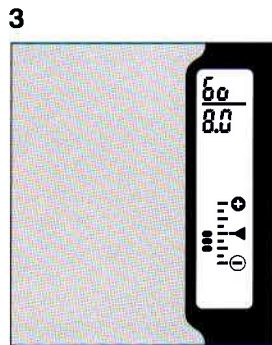
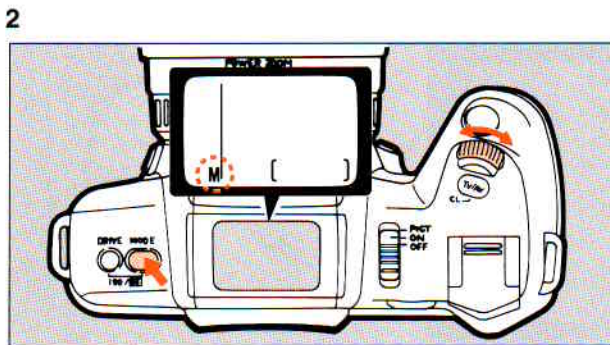
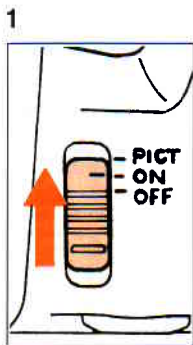

Metered Manual Mode

A proper exposure can be obtained by selecting a combination of shutter speed and aperture according to the meter's indication. However, the Metered Manual mode allows you to adjust that exposure to create different images - for example, over- or underexposing the subject. The camera's metering system is automatically switched to spot-metering when the camera is set in the Metered Manual mode. Spot metering system allows only the central area of the viewfinder to be measured. When in this mode, measure the exposure with this limited small area.



When the shutter release button is depressed while holding down the Hyper button in the Metered Manual Exposure Mode, the shutter speed and aperture vary according to the ambient brightness, which is similar to the Shutter-Priority Exposure Mode or the Aperture-Priority Exposure Mode.

When the Lens Aperture Ring Is Turned to "A" (auto).

1. Move the camera's Main Switch to [ON] .
2. While holding down the Mode Button, turn the Select Dial until [M] is displayed on the LCD panel.
 - The selected shutter speed/aperture and the bar graph are displayed on the LCD panel.
3. When the shutter release button is depressed halfway down, the selected shutter speed/aperture and the bar graph will be displayed in the viewfinder.

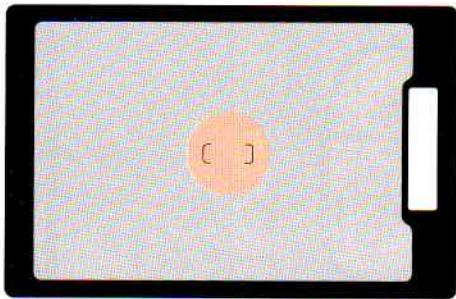





4

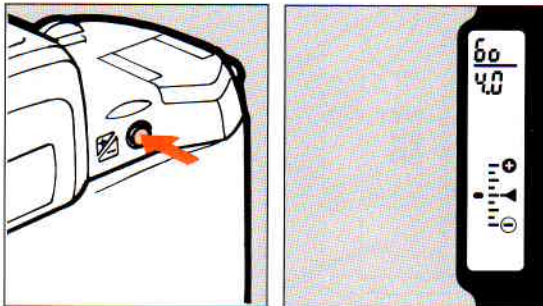

4. Aim the camera's frame in the center of the viewfinder toward a subject to measure the exposure.
- Spot metering system pinpoints light metering in a very small portion of the image field. When the contrast between the main subject positioned in this small area and another subject occupying a relatively large area is great, the favorable result may not be obtained unless scene contrast is taken into consideration.
5. When the Hyper Button [] is depressed and [] is displayed on the LCD panel, the shutter speed remains unchanged while the aperture is adjusted for proper exposure: when [] is displayed on the LCD panel, the aperture remains unchanged while the shutter speed is adjusted for proper exposure (Hyper Manual). At this time, dots appear in the center of the bar graph in both the viewfinder and LCD panel indications, confirming correct exposure. Then, adjust the aperture and/or the shutter speed for the desired exposure.

5



- To change the shutter speed, depress the Tv/Av Button. [] appears above **Tv** on the LCD panel and a bar underneath a shutter speed in the viewfinder indication. Turning the Select Dial to the right increases the shutter speed, while turning it to the left decreases the shutter speed.
To change the aperture, depress the Tv/Av Button. [] appears above **Av** on the LCD panel and a bar underneath an aperture in the viewfinder indication. Turning the Select Dial to the right closes down the aperture, while turning it to the left opens up the aperture.
- When dots are displayed to the [] side, it indicates that the exposure biases towards underexposure. When dots are displayed to the [] side, it means that the exposure biases towards overexposure. Bar graph is calibrated in 0.5EV. When the exposure biases beyond $\pm 2EV$, [] or [] will blink.

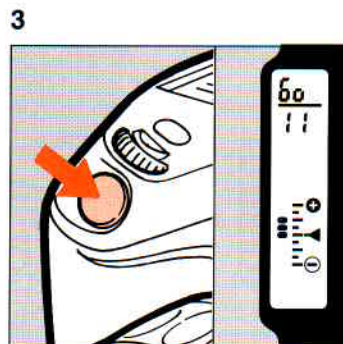
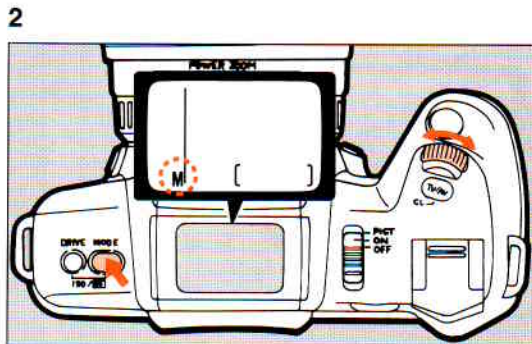
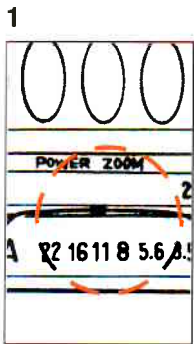

When the Lens Aperture Ring Is at a Position Other Than "A" (Auto)
(Set the Main Switch to [ON] or [PICT].)

1. Turn the lens aperture ring to a position other than "A".
2. While holding down the Mode Button, turn the Select Dial until [M] is displayed on the LCD panel.
- A shutter speed and bar graph are displayed on the LCD panel.
3. When the shutter release button is depressed halfway down, a shutter speed and bar graph will be displayed in the viewfinder. Adjust the aperture with the lens

aperture ring and the shutter speed with the Select Dial.

- When the lens in use is an F or FA lens, the approximate aperture value will appear in the viewfinder and on the LCD panel by half-depression of the shutter release button. With other lenses, no indication will appear.
- Adjust the exposure in a similar manner as when the lens aperture ring is set at "A" (auto).
- Pressing the Hyper button [] will immediately adjust the shutter speed for a correct exposure (Hyper Manual).
- When using a Pentax A-series 50mm f/1.2 lens, set the lens aperture ring to A (auto).

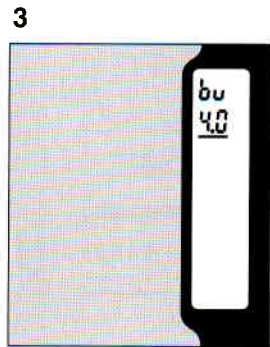
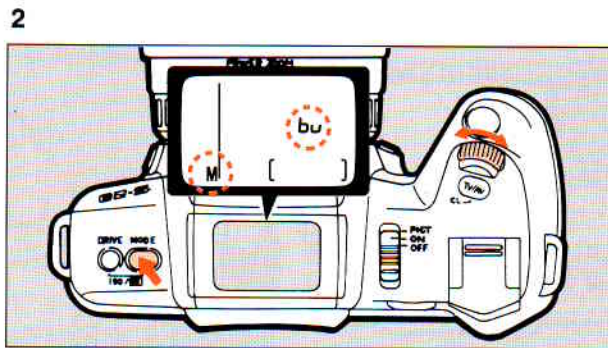
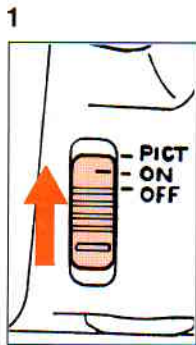

Manual (Bulb) Mode

This mode is useful for long exposures required from shooting fireworks and night scenes, for instance. The shutter remains open as long as the shutter release button is held down.

When the Lens Aperture Ring Is Set at "A" (auto).

1. Move the camera's Main Switch to [ON].
2. While holding down the Mode Button, turn the Select Dial so that [M] and [bu] appear on the LCD panel. An aperture is displayed on the LCD panel.

3. When the shutter release button is depressed halfway down, [bu] and an aperture are displayed on the LCD panel.

4

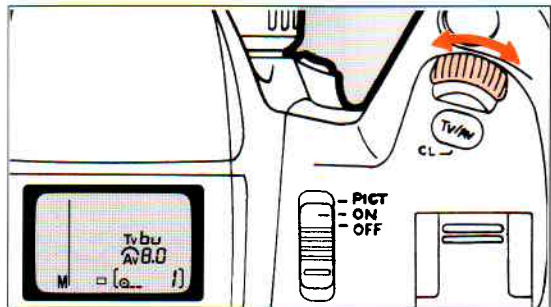



4. Select the desired aperture with the Select Dial.
 - Turning the Select Dial to the right closes down the aperture, while turning it to the left opens up the aperture.

When the Lens Aperture Ring Is at a Position Other Than "A" (auto).

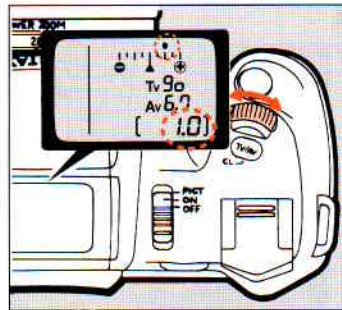
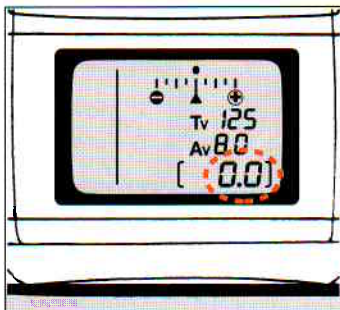
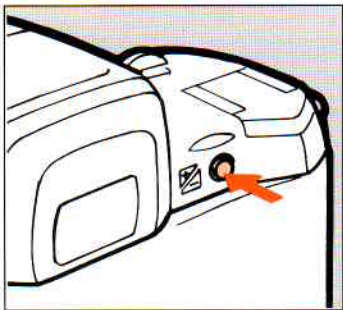

1. Move the Main Switch to [**ON**] or [**PICT**] .
2. Turn the lens aperture ring to a position other than "A".
3. While holding down the Mode Button, turn the Select Dial until [**M**] and [**bv**] are displayed on the LCD panel.
4. When the shutter release button is depressed halfway down, [**bv**] is displayed in the viewfinder.
 - When the lens in use is an F or FA lens, the approximate aperture value will appear in the viewfinder and on the LCD panel by half-depression of the shutter release button. With other lenses, no indication will appear.
 - When using this mode, use a sturdy tripod and the optional "Cable Switch F".
 - Up to approx. 6 hours of time exposure are possible at room temperatures with a new lithium battery.

(6) ABOUT EXPOSURE COMPENSATION



The exposure compensation allows you to deliberately overexpose (brighten) or underexpose (darken) a subject. When the Hyper button [] is depressed, the compensation value and bar graph will be displayed on the LCD panel and in the viewfinder. Select the desired compensation value by turning the Select Dial while holding down the Hyper button.

- The exposure compensation does not work in the Metered Manual Exposure mode, Bulb mode and Green Operation Mode.
- Exposure compensation is possible in the range from +3EV to -3EV in 0.5 EV step.
- A compensation value is displayed within +/-2EV in 0.5EV step on the bar graph. When a compensation value you set exceeds this range, a dot will blink on the bar graph.

- During an exposure compensation in the Picture Mode, [] or [] will be displayed in the viewfinder and on the LCD panel. When a mode other than a Picture Mode is in use or when the lens aperture ring is set at a position other than "A" (auto) in the Picture Mode, a dot representative for a compensation value will appear on the bar graph in the viewfinder and on the LCD panel.
- To cancel the exposure compensation, reset the corrected value to 0.0 by depressing the Tv/Av Button while holding down the Hyper button.
- Even when the camera's Main Switch is set to [**OFF**] or the exposure mode is switched, the exposure compensation is not canceled.

(7) SELECTING A DRIVE MODE

This camera has a total of three drive modes as shown.

Types of Drive Modes

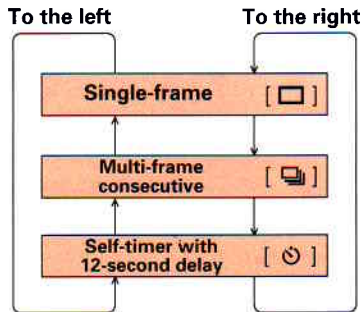

- [□] : One picture is taken at each press of shutter release button.
- [📷] : Pictures can be taken consecutively while holding down the shutter release button.
- [⌚] : A picture is taken with a 12-second-delay.

Changing the Drive Mode

While holding down the Drive Button, turn the Select Dial to set the desired mode.

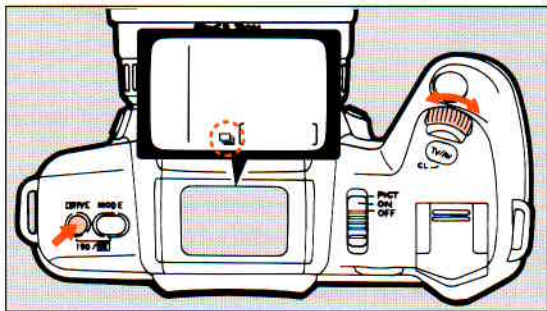

1) Consecutive Photography

A photo can be taken consecutively while the shutter release button is held down.

1. While depressing the Drive Button, turn the Select Dial to Consecutive Shooting [].
2. Depress the shutter release button fully to take a photo.
 - While the shutter release button is held down, photos are shot consecutively.
 - The camera focuses on the subject frame by frame in this mode. However, the shutter cannot be released unless the camera has confirmed sharp focus.

1

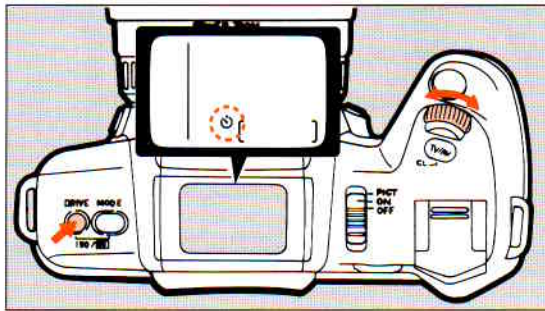

2) Self-Timer Mode

The Self-Timer mode delays the shutter release, allowing the photographer to include himself/herself in the picture.

1. Set the Drive Mode to Self-Timer [] by turning the Select Dial while holding down the Drive Button.

2

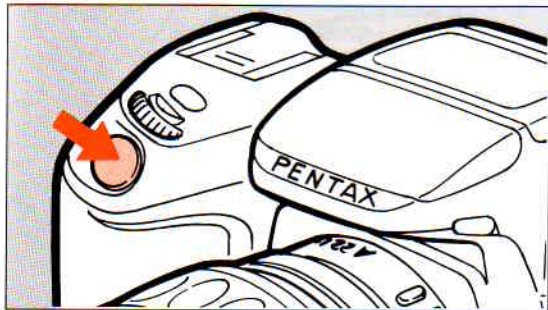

2. Focus on the subject first with the AF frame by depressing the shutter release button halfway down, and then depress the shutter release button fully. The shutter will release in about 12 seconds.
 - When the Self-Timer is in operation, audible PCV signal is delivered: the signal is delivered at a faster pace for the last two seconds, letting you know when to smile.
 - To cancel the Self-Timer operation after it has been activated and before the shot is taken, move the camera's Main Switch to [OFF].
 - If you back away from the viewfinder during a Self-Timer operation, underexposure may result due to light entering the camera through the viewfinder.

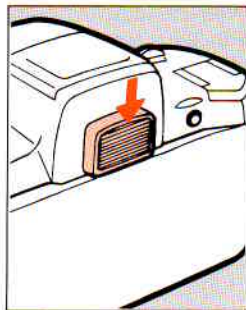
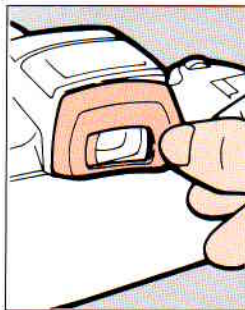

Attach the supplied finder cap when taking Self-Timer photography to prevent stray light entering the camera.

- When using accessories such as the "Correction Lens M" and "Finder Cap", remove the "Eyecup F_E".
- The Eyecup F_E comes from the factory fitted to the camera's viewfinder accessory grooves.
- When you want to use an Eyecup in combination with a "Correction Lens M", combine the optional "Eyecup MII" with a "Correction Lens for 67".
- When you lift your finger from the shutter release button before the shutter is released in the Bulb and Self-Timer modes, the camera uses a shutter speed of 1/60 sec.

(8) EXTENDED POWER ZOOM FUNCTIONS

With a Pentax-FA Zoom lens, the following Auto Zoom Functions are made possible:

- ① Zoom Clip Mode
- ② Image Size Tracking Mode
- ③ Auto Zoom Effect Mode

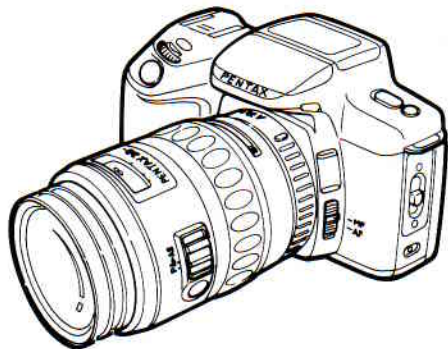

1

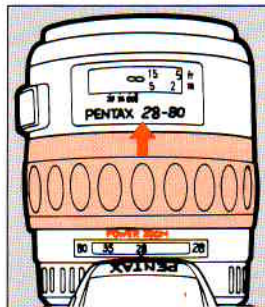

2

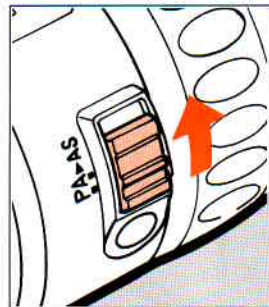

Preparing for Using the Auto Zoom Function

1. Push the power zoom ring forward until the words **POWER ZOOM** appear beneath the zoom ring as shown in the illustration.
 - The zoom lens comes from the factory with the power zoom ring in this position.
2. Set the lens Auto Zoom Switch to "A" (auto).
 - Now you are ready to use the Auto Zoom functions. For details of the available functions, see each page.

1

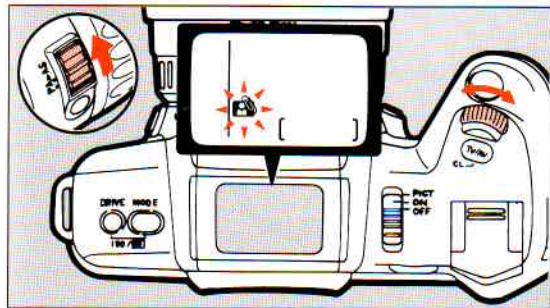

① ZOOM CLIP MODE

With the Zoom Clip Mode, you can preset a focal length for a desired picture area and return to that preset focal length instantly regardless of the setting you might be using by just depressing the lens Zoom Set Button. Zoom Clip Mode is useful for action photography such as sports and snapshots.

2



1. While holding the Auto Zoom Switch on the lens barrel toward [**AS**], turn the Select Dial until [] blinks on the LCD panel.
 - To cancel the Zoom Clip Mode, return the Auto Zoom Switch to [**P**].
2. While looking through the viewfinder, turn the zoom ring to set the desired focal length.



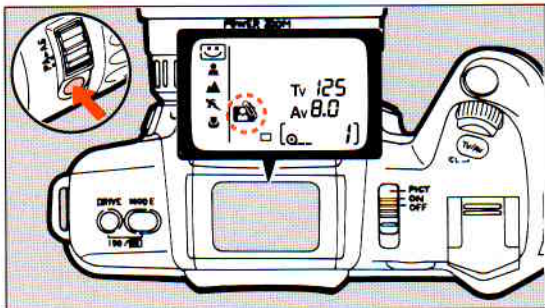

3

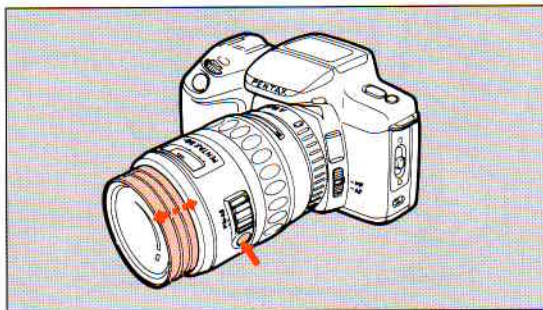

3. Depress the lens Zoom Set Button. [] lights up to indicate that the focal length you set has been entered.
 - Entry of another focal length clears a previous focal length.
 - The focal length stored in memory is not cleared even if the camera's Main Switch is set to [**OFF**]. However, when the battery is replaced, the stored focal length is cleared.
 - If the lens is removed or replaced while the camera's Main Switch is set at [**ON**] or [**PICT**], the stored focal length will be cleared from memory. To prevent this, set the camera's Main Switch to [**OFF**] prior to replacing the lens.

4





4. Depress the Zoom Set Button and the focal length held in memory will return. Depress the shutter release button fully to take a photograph.
 - When the Zoom Set Button is depressed, the lens zooms while maintaining sharp picture focus. However, [] will not appear and the PCV signal will not be heard for focus confirmation.

② IMAGE SIZE TRACKING MODE

In this mode, the camera will automatically zoom the lens to always capture the subject at the preset image size regardless of the distance to the subject (within the constraints of the focal length range). This mode allows you to take a picture of a child coming towards or going away from you with the same preset image size.

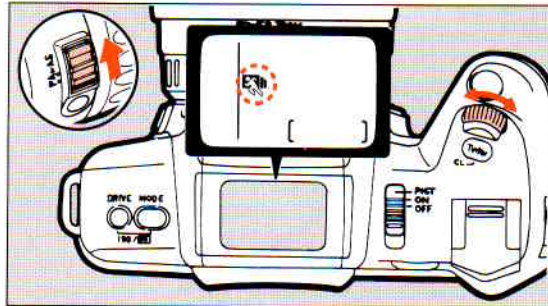
1



1. While holding the Auto Zoom Switch on the lens barrel toward [**AS**], turn the Select Dial until [] appears on the LCD panel.
 - When the focus mode switch is set to [**MF**], this mode cannot be used.



2



2. While looking through the viewfinder, turn the zoom ring to zoom the lens to the desired setting.
 - At this time the lens zooms while maintaining sharp picture focus.

3

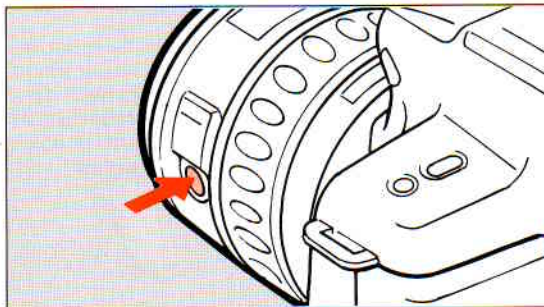

3. Depress the lens Zoom Set Button. The image size you set has been entered.
 - At this time the PCV signal is heard, letting you know that the image size has been entered.

4

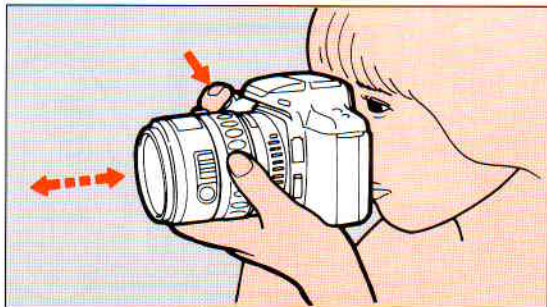

4. Depress the shutter release button halfway down. The camera automatically zooms the lens to always capture the subject at the preset image size regardless of the distance to the subject (within the constraints of the focal length range). Depress the shutter release button fully after the lens finishes zooming.
 - To cancel the Image Size Tracking Mode, return the Auto Zoom Switch to [P].
 - Releasing the shutter before completion of zooming operation may not yield a preset image size: to get the desired image size release the shutter only after the lens finishes zooming.

- If the camera-to-subject distance is too close or far, the preset image size may not be obtained as this mode works effectively only within the constraints of the focal length range. In addition, since the preset image size works only on the lens currently in use, the preset image size may not be obtained if the lens is replaced with another.
- When the focus mode switch is set at [MF] in the Image-Size Tracking Mode, the mode is switched from Image-Size Tracking to Zoom Clip Mode.
- The image size stored in memory is not cleared even if the camera's Main Switch is set to [OFF].
- If the lens is removed or replaced while the camera's Main Switch is set at [ON] or [PICT], the stored image size will be cleared from memory. To prevent this, set the camera's Main Switch to [OFF] prior to replacing the lens.
- Entry of another image size clears a previous image size.
- Setting the lens focal length to the middle of its range for the desired image size will provide the most versatility. For instance, set the 28-80mm lens to around 50mm.
- When the battery is replaced, keep in mind that a preset image size is cleared.



③ ZOOM EFFECT

In the Zoom Effect Mode, the lens zooms automatically from wide-angle to telephoto during an exposure, resulting in the subject's contours becoming radially blurred while the subject's core is clearly photographed.

1

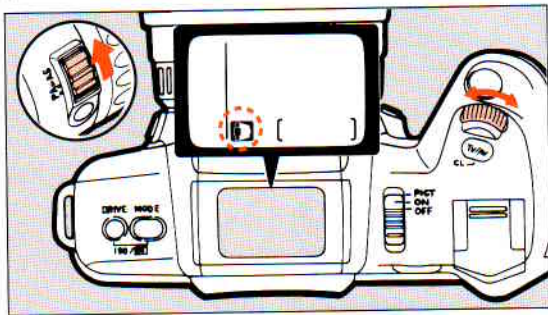

1. While holding the lens Auto Zoom Switch toward [AS], turn the Select Dial until [] appears on the LCD panel.
 - The bar graph will appear in the viewfinder and on the LCD panel only when the Metered-Manual Exposure Mode is in use.
 - To cancel the Zoom Effect Mode, move the lens Auto Zoom Switch to [P].
 - When the Zoom Effect Mode is set while the Hyper Program-Shift is executed, the bar graph will disappear. However, the shifted amount stays in memory.

2



2. Set the power zoom ring to a wide-angle position to create distinctive effects.

- When the lens is at its tele end, the lens zooms from telephoto to wide-angle position.
- Set an exposure so that as slow a shutter speed as possible is selected to create a dramatic effect: with a faster shutter speed, the dramatic zooming effect is not produced.
- In the Picture Mode and Programmed AE Mode, the camera automatically sets an exposure which allows the use of as slow a shutter speed as possible.
- After the shutter is released, zooming starts automatically when exposure reaches half of the total designated exposure time. For example, if the shutter speed is set to 1 second, the lens starts zooming when 0.5 second has elapsed after the shutter is released.

3

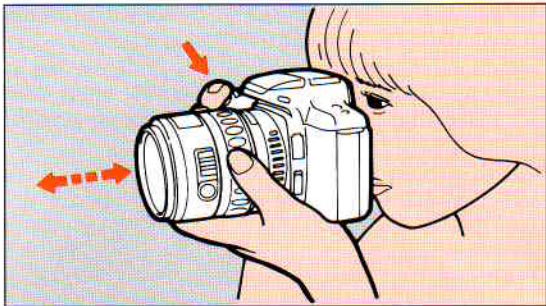

3. Depress the shutter release button fully. The lens zooms according to the selected shutter speed, creating a dynamic zoom effect.



- Faster shutter speeds reduce the zooming time, making it almost impossible to produce a Zoom Effect. For example, a 28-80mm zoom lens takes about 1 second to zoom from the 28mm position to the 80mm position. Thus, a shutter speed of at least 2 seconds is required to produce a full zoom effect. If the shutter speed is too slow, the shutter remains open after the lens finishes zooming, producing two image cores of one subject in two different sizes on a single frame.
- If the zooming range is too extreme, the image becomes difficult to see due to excessively increased blur.
- The lens zooms at the maximum zooming speed in the Zoom Effect Mode.
- Use of a tripod is recommended to prevent camera shake.

(9) USING THE BUILT-IN FLASH (RTF)

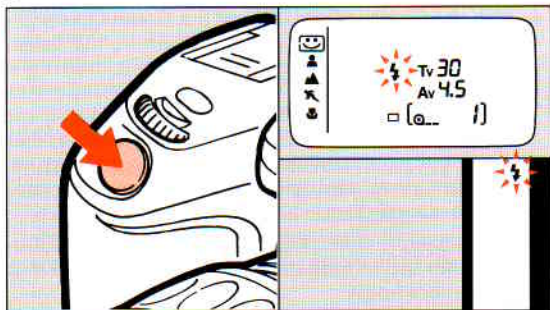
1





When using the camera's built-in flash in a dark or backlit situation, the camera automatically chooses an optimum combination of shutter speed and aperture according to the subject brightness, allowing you to take a flash photograph with ease.

1. Select the Picture Mode or Programmed AE Mode and depress the shutter release button halfway down.
 - In a dark or backlit situation, [] and [] will blink respectively on the LCD panel and in the viewfinder to recommend the use of flash.

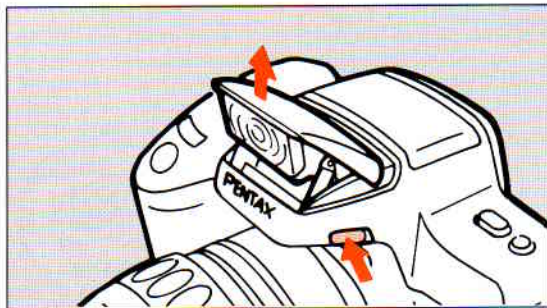
2



2. Depress the flash pop-up button to activate the built-in flash.
 - The built-in flash starts charging automatically. When it is fully charged, [] lights up on the LCD panel. In addition, [] lights up in the viewfinder when the shutter release button is depressed halfway down.
 - The shutter cannot be released while the flash unit is being charged.
 - When the built-in flash is activated while the Hyper Program-Shift is executed, the bar graph will disappear. However, the shifted amount stays in memory.

3

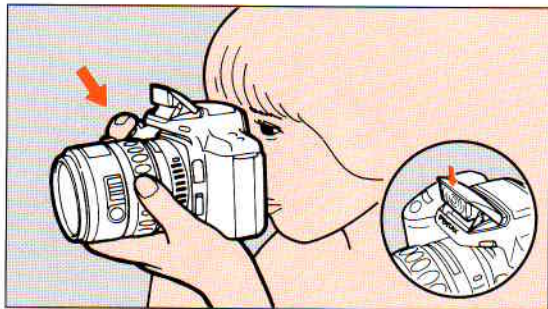

3. Depress the shutter release button fully to take a flash photograph.
- The shutter speed changes in the range from 1/100 to 1/30 sec., and the slowest shutter speed depends on the focal length of the lens in use. The shutter speed of 1/100 sec. is automatically selected when a lens made before the Pentax A-series lens is used or when the Action Program Mode is selected.

- With the Picture Mode (except the Green Operation Mode) or Programmed AE Mode, turning the Select Dial lets you use Hyper Program-Shift, making it possible to change a shutter speed/aperture combination. Hyper Program-Shift works in the aperture range that couples with a shutter speed of 1/100 sec. or slower. When the shutter speed becomes slow, camera shake is likely to blur your picture, so use a tripod.
- After taking a flash photograph, retract the built-in flash into the camera body by pushing it down into the camera body.

When in the Shutter-Priority AE mode

When using the built-in flash in the Shutter-Priority AE mode, you can take a flash photograph with the shutter speed of 1/100 sec. or slower. In the Shutter-Priority AE mode, the aperture setting automatically changes with the ambient brightness, making flash photography easy.

When in Aperture-Priority AE or Metered Manual Exposure Mode

This mode is useful to take a flash photograph with a selected in-focus range (depth of field) by setting a desired aperture. In the Aperture-Priority AE Mode, the shutter speed changes according to the ambient brightness, making flash photography easy.

- The shutter speed changes in the range from 1/100 to 1/30 sec., and the slowest shutter speed depends on the focal length of the lens mounted on the camera. When a lens made before the Pentax A-series is used, the camera uses the shutter speed of 1/100 sec.

Calculating Flash Effective Distance According to the Selected Aperture

Maximum flash distance = $GN \div \text{Selected aperture}$
 Minimum flash distance = Maximum flash distance $\div 5$
 When the distance to the subject is less than 0.7m, flash cannot be used.
 *GN: Guide Number

Calculating the aperture according to the camera-to-subject distance

Aperture = $GN \div \text{Camera-to-subject distance}$

If the calculated aperture value is the one other than an f-stop on the aperture ring, for example f/3, choose the next smallest aperture that is an f-stop on the aperture ring (f/2.8 in this case).

The guide numbers depend upon the film speed used as shown below.

ISO25 → GN6.5	ISO200 → GN18
ISO50 → GN9.2	ISO400 → GN26
ISO100 → GN13	

If an ISO100 film is used at an aperture of f/4.7, the flash effective distance is obtained as follows:

$$GN13 \div f/4.7 = 2.8\text{m}$$

$$2.8 \div 5 = \text{Approx. } 0.56$$

Thus, flash effective distance ranges from approx. 0.7m to 2.8m.



Without Daylight-Sync



With Daylight-Sync

Daylight-Synch Flash

In the Picture Mode or Programmed AE, Shutter Priority AE or Aperture-Priority AE Mode, the shutter speed or aperture changes according to the ambient brightness, making Daylight-Synch flash photography easy, which would otherwise require complicated exposure control. When shooting in a lighting condition that results in a shutter speed of 1/100 sec. or slower, keep in mind that the background may be overexposed.



Slow-Speed-Synch

Slow-speed-sync flash operation works in the Metered Manual Exposure Mode and Shutter-Priority Exposure Mode.

- Metered Manual Exposure Mode

1. Activate the flash by depressing the flash pop-up button.
2. Set the camera's exposure mode on manual.
3. Select an appropriate shutter speed/aperture combination for a correct exposure.
4. Focus the lens on the subject and shoot.
 - The step 1 can be followed at any time before advancing to the step 4.

- Shutter-Priority Exposure Mode

1. Set the Shutter-Priority AE Mode.
2. Set the desired shutter speed.
 - When the aperture blinks in the viewfinder and on the LCD panel, it means that the correct exposure will not be obtained: adjust the shutter speed until the aperture stops blinking.
3. Press the flash pop-up button to activate the built-in flash.
4. Take a photograph.
 - Use of a tripod is recommended to prevent camera shake.