

POSTED 6-27-'04

This manual is for reference and historical purposes, all rights reserved.

This page is copyright © by M. Butkus, NJ.

This page may not be sold or distributed without the expressed permission of the producer

I have no connection with any camera company

On-line camera manual library

This is the full text and images from the manual.

This may take 3 full minutes for this PDF document to download.

The main page is located at [www.butkus.org/chinon](http://www.butkus.org/chinon)

**If you find this manual useful, how about a donation of \$3 to:  
M. Butkus, 29 Lake Ave., High Bridge, NJ 08829-1701  
and send your e-mail address so I can thank you.**

**Most other places would charge you \$7.50 for a electronic copy or  
\$18.00 for a hard to read Xerox copy.**

**This will allow me to continue to buy new manuals and pay their shipping costs.**

**It'll make you feel better, won't it?**

If you use Pay Pal or wish to use your credit card, use the Pay Pal Link on my page.

If you found this page from any other location (other then a link)  
please notify me at [mike@butkus.org](mailto:mike@butkus.org)

## II. BASIC OPERATION (SHOOTING)

1

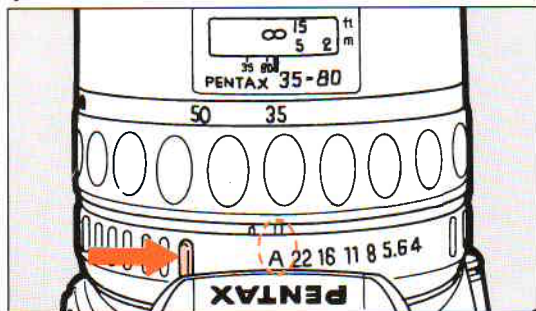

For easy picture taking, use this mode. You simply depress the shutter release button. The camera selects the best combination of aperture and shutter speed automatically.

**Confirm that the lens aperture ring is set to the [ A ] position.**  
**If the aperture ring is set to a position other than the A position, a correct exposure may not be obtained.**

### How to set

**1. Turn the lens aperture ring to the [ A ] position as shown in the illustration.**

- To move the lens aperture ring to the [ A ] position, turn the aperture ring while holding down the aperture-A lock button on the lens.

2

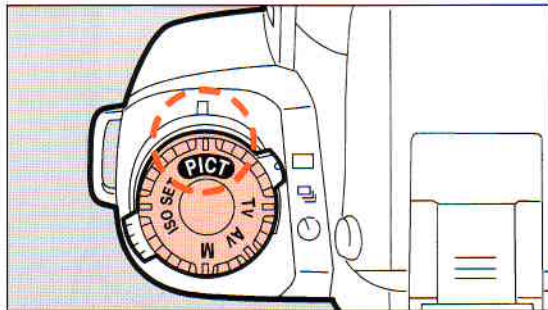

2. Set the mode dial to the [ PICT ] position.

3

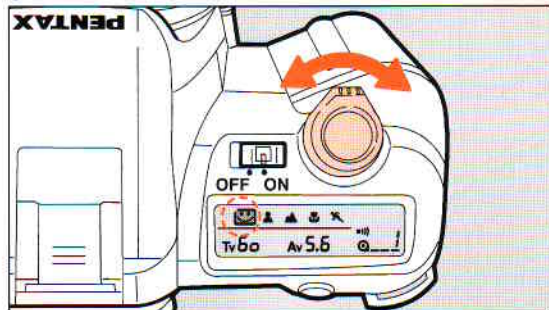

3. Move the select switch until [ ] superimposes on [ ].

- See page 54 for any other exposure mode.

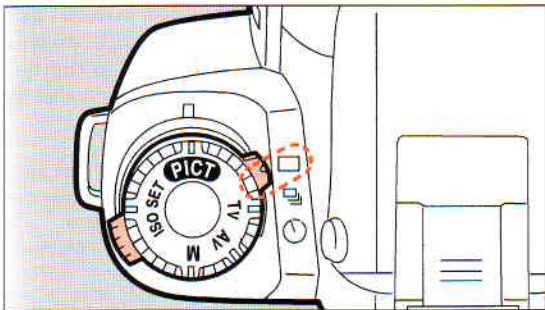

Set the drive mode switch to the [□] position.

- One picture is taken each time the shutter release button is depressed.
- See page 46 for other available function.

### (3) USING ZOOM LENSES



Telephoto



Wide angle

Using the zoom function makes the subject appear larger (telephoto) or smaller (wide angle) in the viewfinder. Turn the zoom ring to the desired position and depress the shutter release button to take a picture.

- The smaller the number shown in the zoom scale window, the wider the angle. Conversely, the larger the number, the more magnified the image appears.
- The Image Size Tracking Mode, Zoom Clip Mode, Auto Zoom Effect Mode and Power Zoom function do not operate with this camera even if an FA lens is attached.

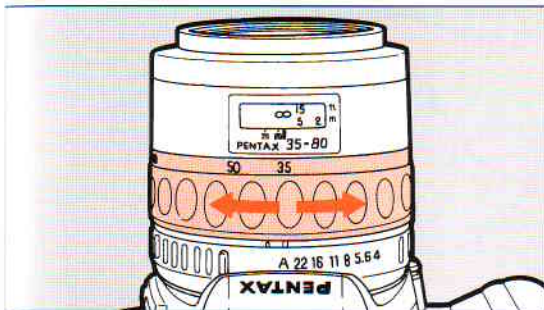

Turning the zoom ring to the right makes the subject appear larger (telephoto) and turning it to the left makes the subject appear smaller (wide angle).

\*

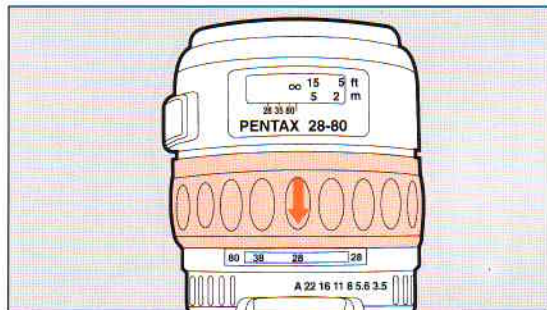

\* Using the manual zoom function with an FA zoom lens attached

Pull the power zoom ring toward the camera body until the wards [POWER ZOOM] are hidden.

# (4) HOLDING THE CAMERA

## Camera held horizontally

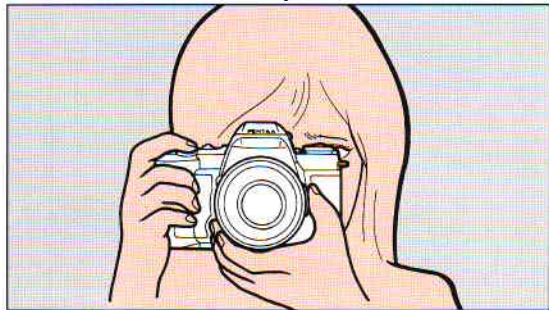

**For best results, be sure to hold the camera correctly as shown in the illustrations.**

- Hold the camera firmly with your left hand supporting the camera and lens as shown in the illustrations.
- While taking a picture, hold your breath and gently depress the shutter release button. Sudden force on the shutter release button will cause camera shake, making the picture blurred.

## Camera held vertically

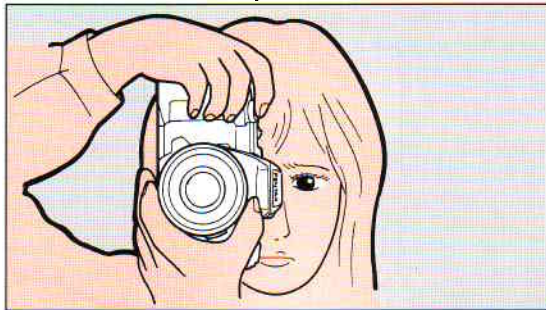

- To reduce camera shake, support your body or the camera on a solid object - a table, tree, or a wall for instance.
- When using an ultra-telephoto lens, a tripod that is heavier than the total weight of the camera and lens is recommended to avoid camera shake.
- Although there are individual differences among photographers, in general the shutter speed for a hand held camera is the inverse of the focal length. For example,  $1/50$  of second when the focal length is 50mm, and  $1/100$  of second when it is 100mm. Using a tripod is recommended when the shutter speed is slower than this.

# (5) SELECTING THE AUTOFOCUS MODE

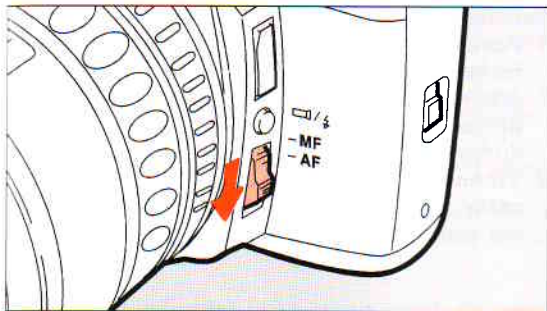

Set the focus mode switch to [ AF ].



- When you depress the shutter release button halfway down, the lens automatically focuses.
- See page 49 for manual focusing.





## (6) TAKING A PICTURE



Set the focus mode switch to [ AF ].

1. Focus on the subject with the autofocus frame [  ] indicated in red in the photograph. When the shutter release button is depressed halfway down, the lens automatically focuses.
2. When the subject is in focus, the focus indicator [  ] lights up and an audible PCV beeping signal is emitted.

- When the shutter release button is depressed halfway down, the shutter speed and aperture setting are displayed in the viewfinder and the on LCD panel.
- When [  ] blinks in the viewfinder and on the LCD panel, the use of the built-in flash is recommended. For more details on the built-in flash, see page 37.
- The audible PCV signal can be turned OFF. See details on page 69.
- During autofocus operation, the focusing ring should not be obstructed with your fingers, hands, or any other object.

**The focus indicator [  ] blinks when the camera is not able to obtain proper focus for one of the following reasons.**

- ① The subject is too close. Adjust the camera-to-subject distance.
- ② The subject is difficult to autofocus. See "HARD-TO-AUTOFOCUS" subject on page 52.

### **3. To release the shutter, gently depress the shutter release button fully.**

- The shutter cannot be released if the subject is out of focus.
- Depress the shutter release button halfway down. While [  ] is on, the camera-to-subject distance is fixed (focus lock). To refocus on another subject, lift your finger off the shutter release button.

#### **Predictive Autofocus Mode**

When the camera senses subject movement during the autofocus operation, the camera will automatically switch the focus mode to the predictive autofocus mode to measure the speed of a moving subject, and predict where it will be at the moment of shutter release to maintain sharp focus on the subject.

- If the subject is moving too fast, the shutter may not release.

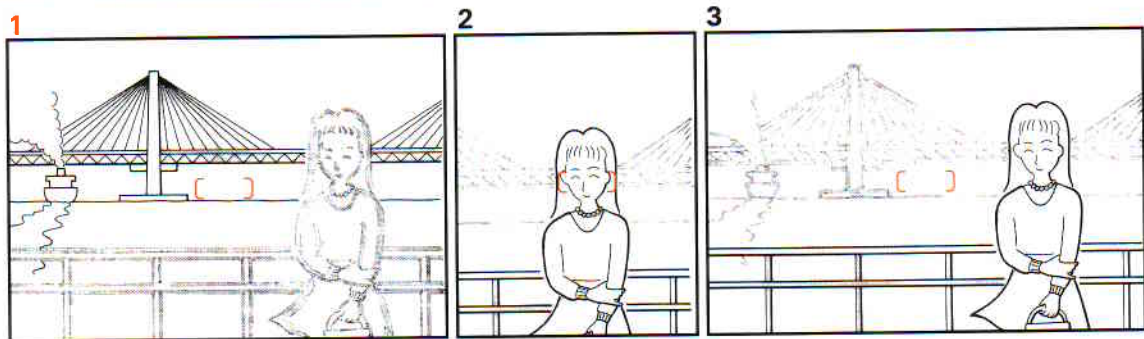

## Focus Lock Function

### Purpose

The camera focuses with the autofocus frame in the center of the viewfinder. When the main subject is off the autofocus frame, the main subject will not be focused properly. Use the focus lock technique to bring the main subject into focus.

### How to use

**1. When the composition does not allow the autofocus frame to be placed over the most important subject in the picture, the camera will focus on the background as shown in the illustration.**

**2. To prevent this, center the autofocus frame on the main subject and keep depressing the shutter release button halfway down. The in-focus indicator remains on, indicating that the focus is temporarily locked.**

**3. While holding the shutter release button halfway down, re-aim the camera or recompose the picture, then depress the shutter release button all the way to release the shutter.**

- Lifting your finger off the shutter release button clears the in-focus indicator [  ] in the viewfinder and cancels the focus lock function.
- To refocus on another subject, lift your finger off the shutter release button.

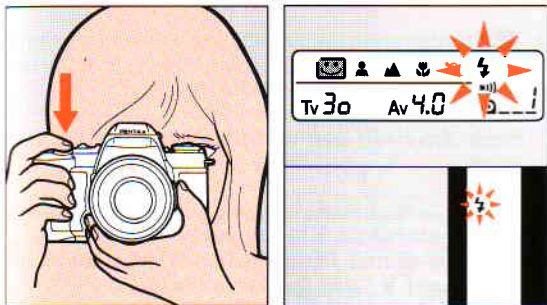

## The Flash-Recommended Indicator

If the built-in flash is recommended, the flash-recommended indicator [⚡] starts blinking in the viewfinder and on the LCD panel when the shutter release button is depressed halfway down.

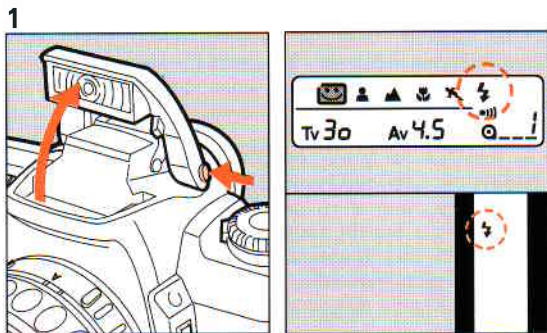

- In the Picture Mode and the Aperture-Priority AE Mode, the flash-recommended indicator [⚡] blinks when you attempt to photograph a subject in low light, or in a backlit situation. In the Shutter-Priority AE Mode and Metered Manual Mode, the flash-recommended indicator blinks only when attempting to photograph a subject in a backlit situation.



## Using the built-in flash

If [  A ] is displayed on the LCD panel, it indicates that the automatic flash function is set. Delete it from the LCD panel. See page 45 for more details.

### 1. Push the flash pop-up button to activate the flash.

- The built-in flash starts charging automatically. When it is fully charged, [  ] appears on the LCD panel. When the shutter release button is depressed halfway down, [  ] also appears in the viewfinder.
- When the built-in flash is used, using a lens hood is NOT recommended as it may obstruct the path of the light coming from the flash, causing vignetting in the picture corners.

2

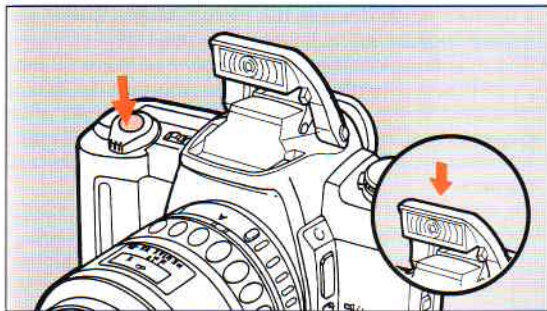

**2. Depress the shutter release button fully, and the flash unit discharges. After using the flash, retract the built-in flash by pressing it down into the camera body.**

- The shutter cannot be released until the flash is fully charged.
- If the built-in flash is used continuously, the battery may become warm, but it does not mean the battery is faulty; it is one of the battery's characteristics.
- With the built-in flash popped-up, an external flash cannot be attached to the hot shoe. If you would like to use an external flash together with the built-in flash, see the flash connections on page 77.

## Flash effective range in the Picture Mode with ISO 100 (400) is used

Maximum Lens Aperture	Effective Range
f/1.4	approx. 0.8 - 3.9m (0.8- 5.6m) 2.6 - 12.8ft (2.6-18.4ft)
f/2	approx. 0.8 - 3.3m (0.8- 4.8m) 2.6 - 10.8ft (2.6-15.7ft)
f/2.8	approx. 0.7 - 2.8m (0.7- 4.0m) 2.3 - 9.2ft (2.3-13.1ft)
f/3.5, f/4.7	approx. 0.7 - 2.4m (0.7- 4.0m) 2.3 - 7.9ft (2.3-13.1ft)
f/5.6	approx. 0.7 - 2.0m (0.7- 4.0m) 2.3 - 6.6ft (2.3-13.1ft)

The effective range of the flash depends on the maximum aperture of the lens is in use. A lens with a maximum aperture of f/1.4 is marked as 1:1.4 on its barrel.

- This effective range table is only applicable when the exposure mode is set in the Picture Mode. When any other exposure mode is used, see page 71.
- The minimum effective range is always 0.7m (2.6ft) even if a lens with a maximum aperture f/2.8 or smaller is in use. When a subject is shot at a distance closer than 0.7m (2.6ft), the correct exposure cannot be obtained, and you will see vignetting in the picture corners.

### Inappropriate lens warning when the built-in flash is used

When using an inappropriate F- or FA- lens, [  ] will blink in the viewfinder and on the LCD panel when the shutter release button is depressed halfway down. For more details on **COMPATIBILITY OF F AND FA LENSES WITH THE BUILT-IN FLASH**, see page 72.

- Taking a picture while this warning is displayed may cause vignetting in the picture corners or semi-circular vignetting at the bottom of the picture.
- When lenses other than an F or FA are used, this warning will not appear.



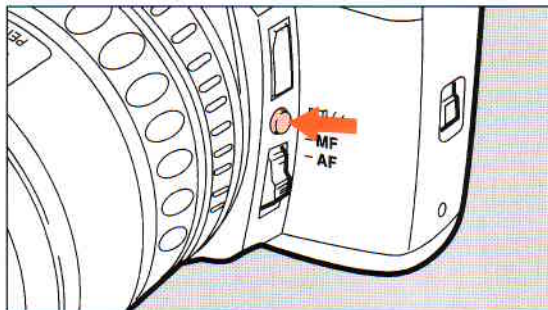

### Depress the multi-function button with the built-in flash popped up

At each press of the multi-function button, the flash mode on the LCD panel switches as shown in the chart.

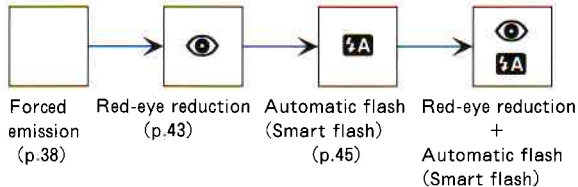

- The Automatic flash function will be set only with the Picture Mode set. If any other mode is set, the Red-eye reduction or Forced emission mode will be set.
- When the built-in flash is retracted, depressing the multi-function button switches the audible PCV signal ON and OFF.

1

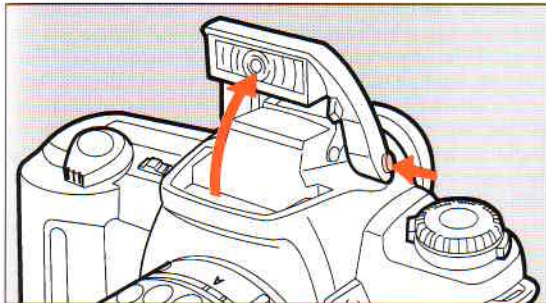

### Red-eye Reduction Flash Function

This camera includes a red-eye reduction flash function, which reduces the red-eye phenomenon utilizing preflash. In this mode, the preflash is discharged just before the shutter is released which reduces the diameter of the pupil of the eye. Then the main flash is discharged while the pupils are smaller, which in turn reduces the red-eye effect.

2

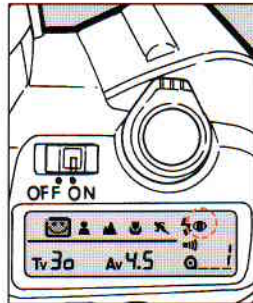
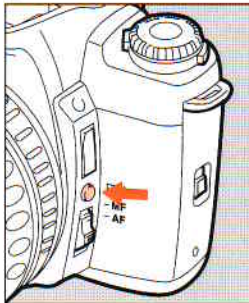

### How to set

1. Push the flash pop-up button to activate the flash.
2. Depress the multi-function button until [👁] appears on the LCD panel.

### How to cancel

With the built-in flash popped-up, depress the multi-function button until [👁] disappears from LCD panel.

- Depress the multi-function button only when the built-in flash popped-up. If multi-function button is depressed with the built-in flash retracted, the PCV Signal Mode will be changed.
- When the AF500FTZ is attached and the slave flash function is in use, the Red-eye reduction flash function cannot be used as the slave flash is discharged when the preflash of the built-in flash is discharged.
- When only a dedicated flash is in use and is discharged, the red-eye reduction display from the LCD panel is disregarded.

### **About Red-eye Phenomenon**

Shooting portraits with flash in a dark environment often causes a subject's eyes to turn out reddish in the print. This phenomenon, commonly known as "Red-Eye", is caused by the reflection of the electronic flash in the retina of your subjects eye. It can be reduced by taking the photo in a brighter light condition or by shooting with a wider angle lens at a closer distance, or by employing the red-eye reduction flash feature. When using a Pentax dedicated flash unit off the camera, it may also help to position the flash as far away from the camera as possible.

1

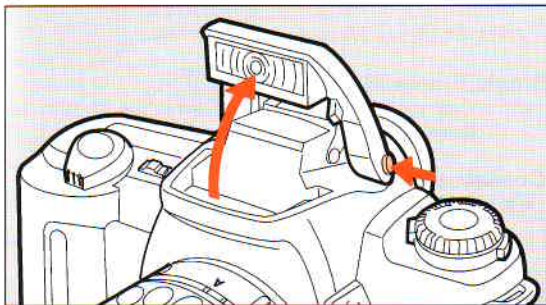

### AUTOMATIC FLASH FUNCTION (SMART FLASH FUNCTION)

This is a convenient built-in flash mode that the flash discharges only when it is necessary even if the flash is in the popped-up position.

#### How to set

1. Push the flash pop-up button to activate the flash.
2. Depress the multi-function button until [  ] appears on the LCD panel.

2

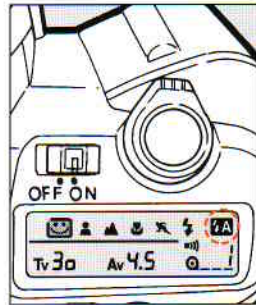
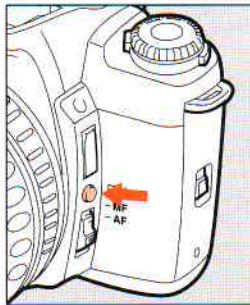

- In the Picture Mode, the automatic flash function will only operate when the subject is in a low light or backlit condition.
- Depress the multi-function button with the built-in flash in its popped up position. If the button is depressed with the built-in flash in its retracted position, the PCV audible beep mode will be switched on/off.

#### How to cancel

With the built-in flash in its popped up position, depress the multi-function button until [  ] disappears from the LCD panel.

This camera has a total of three drive modes as shown.

### Types of Drive Modes

#### Single-Frame Mode

[□] : One picture is taken each time the shutter release button is depressed.

#### Consecutive-Frame Mode

[] : Pictures can be taken consecutively while holding down the shutter release button. See page 47.

#### Self-timer Mode

[] : A picture will be taken with a 12-second-delay. See page 47.

## III. ADVANCED OPERATIONS

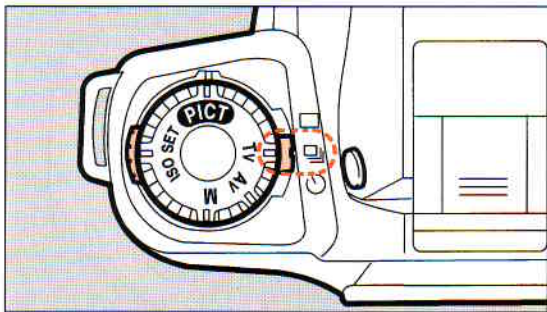

### 1. Consecutive-Frame Mode

Consecutive pictures can be taken by holding down the shutter release button.

#### How to set

Set the drive mode switch to [CON].

- The camera focuses on the subject frame by frame in this mode.
- The shutter cannot be released while the built-in flash is being charged.

1

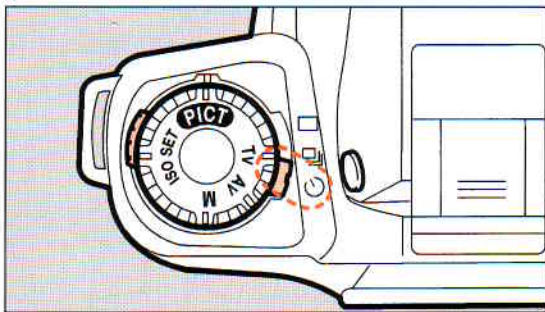

### 2. Self-Timer Mode

The self-timer mode delays the shutter release, and is useful for taking group shots that include the photographer. The shutter will be released about 12 seconds after the shutter release is depressed.

1. Set the drive mode switch to [T].

2

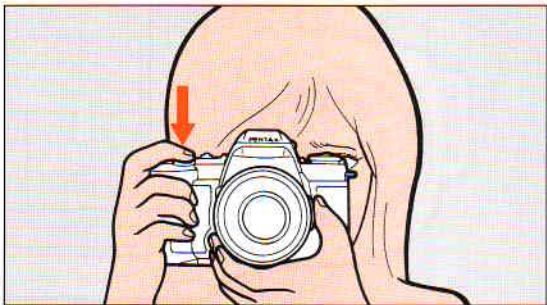

**2. Focus on the subject first using the autofocus frame and by depressing the shutter release button halfway down. Then depress the shutter release button fully.**

- The shutter will be released about 12 seconds later.
- When the self-timer is in operation, the audible PCV signal is heard and the rate increases for the last two seconds.

### How to cancel

To cancel the self-timer operation after it has been activated, move the drive mode switch to a position other than [Ⓢ].

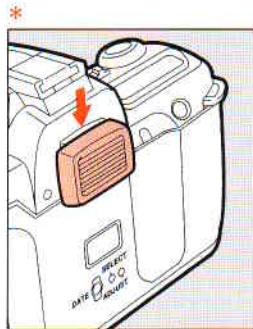
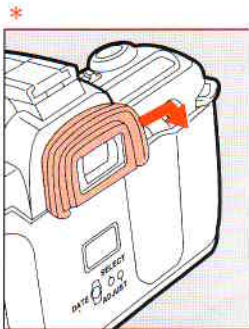

- \* Underexposure may occur if light enters the viewfinder during self-timer operation. If you intend to move away from the viewfinder, attach the supplied finder cap as shown in the illustration.
- \* When using accessories such as the finder cap, remove the Eyecup F<sub>H</sub>. The Eyecup F<sub>H</sub> comes from the factory fitted to the camera's viewfinder accessory grooves.

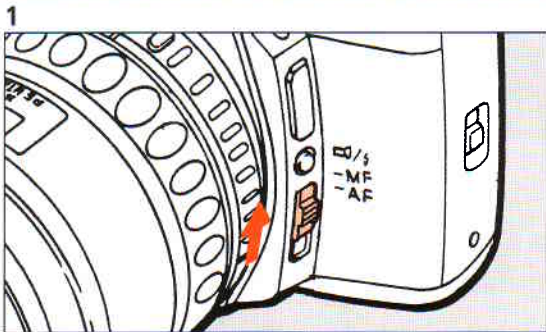

### Using a manual-focus lens

When mounting a non-autofocus lens (A-lens) with a maximum aperture of  $f/5.6$  or larger ( $f/1.2$  to  $f/5.6$ ), you can use the manual focus mode to focus the lens with the aid of the in-focus indicator [◻] in the viewfinder.

- When the subject comes into focus, the focus indicator [◻] lights up in the viewfinder and an audible PCV signal is heard. The audible PCV signal can be canceled. See page 69.

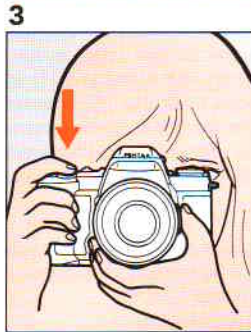
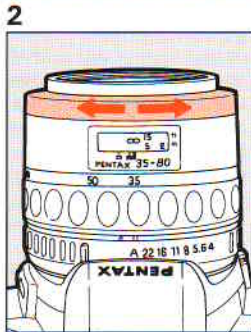

### How to focus

1. Set the focus mode switch to [MF].
2. While looking through the viewfinder, turn the focusing ring to the right or left while holding the shutter release button halfway down.
3. When the subject comes into focus, the in-focus indicator [◻] lights up in the viewfinder. Depress the shutter release button fully to take the photograph.



### **When the autofocus mode or the in-focus indicator is not usable for focusing**

When the autofocus function or the viewfinder's in-focus indicator [⬠] cannot be used for focus confirmation for the following reasons, focus on the subject in the manual focus mode with the aid of the matte field in the viewfinder as you would with a non-AF SLR camera.

- a) The in-focus indicator [⬠] blinks because the subject is difficult to autofocus.
- b) The maximum aperture of the lens in use is smaller than  $f/5.6$ .

1

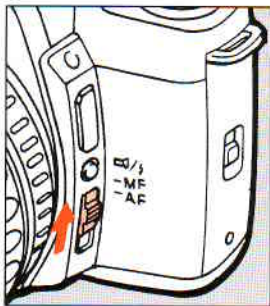

### How to focus on the subject

1. Set the focus mode switch to [ MF ].
2. While looking through the viewfinder, turn the focusing ring to the right or left until the image in the viewfinder is clearest.

2

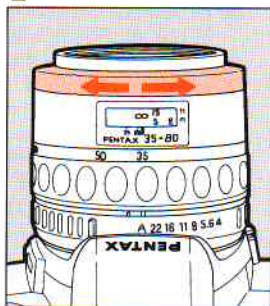

### Using the snap-in focus function

When the subject comes to the point where the lens was prefocused, the shutter is automatically released.

### How to use

1. Use a non-autofocus (A-lens) lens.
2. Set the focus mode switch to [ AF ].
3. Focus at the point where you wish to capture the subject.
4. Using the optional "Cable Switch F", keep the trigger release button depressed so that the autofocus and metering systems stay active.
5. The camera releases the shutter automatically when the subject comes into focus at the point selected.

## HARD-TO-AUTOFOCUS SUBJECTS

The autofocus system is highly precise, but not perfect. Depending on the brightness, contrast, shape, and size of your subject, the autofocus system may not operate. In such a case, set the focus mode switch to [MF] and use the manual focus mode to focus the lens on the subject with the aid of the matte field in the viewfinder (see page 51).

Subjects which may fool the autofocus system include:

- a) Extremely low-contrast subjects such as a white wall in the autofocus frame [C].
- b) Subjects which don't reflect much light in the autofocus frame [C].
- c) Subjects which are moving too fast.
- d) Multiple subjects in the foreground and background of the autofocus frame [C].
- e) Subjects positioned against reflected light or strong backlight or with extremely bright backgrounds.

### Notes on accessories

The following condition does not allow autofocusing or manual focusing with the in-focus indicator in the viewfinder. Use the manual focus mode to focus on the subject with the aid of the matte field surrounding the autofocus frame.

- When using special effect filters or "Magic Image Attachment" or "Stereo Adapter".

### Using a Polarizing Filter

When using an ordinary polarizing filter; the half mirror incorporated into the autofocus system reduces the effectiveness of the autofocus function when used in combination with an ordinary polarizing filter. Use a CIRCULAR POLARIZING FILTER for proper autofocus operation.

# (3) USING THE PICTURE MODE

1

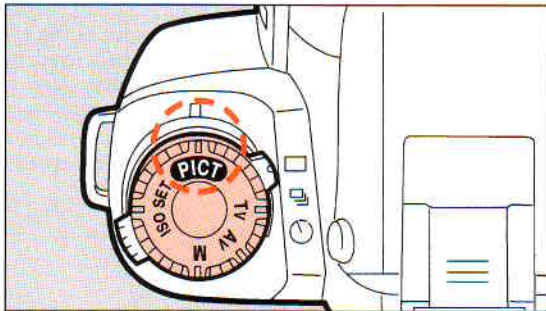

You can also select your desired Picture Mode manually. The picture mode has a total of 5 modes as follows. See details for each mode on page 55 - 59.

## How to set

Set the lens aperture ring to [ A ].

1. Set the mode dial to [ PICT ].

2

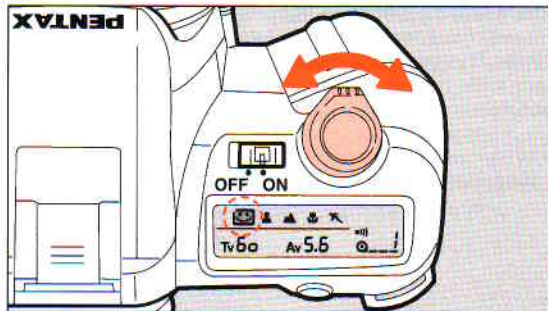

2. To select the desired picture mode, move the select switch until [  ] superimposes on the picture mode displayed on the LCD panel.

- When the lens aperture ring is set to a position other than the A position, a correct exposure may not be obtained.

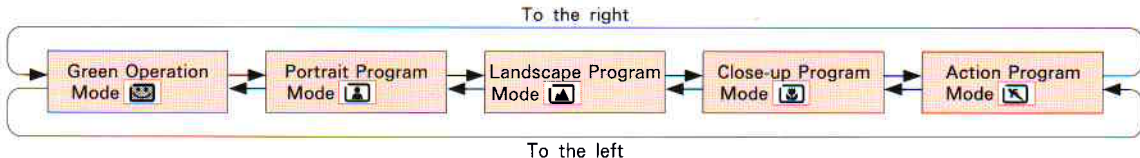

\*

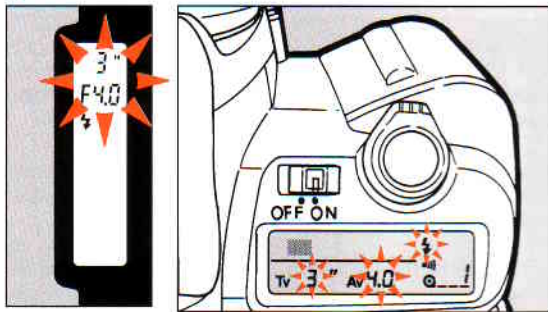

### \* Exposure Warning

If the subject is too bright or too dark, the shutter speed and aperture setting in the viewfinder will blink. If the subject is too bright, select a darker subject. Use a flash if the subject is too dark.

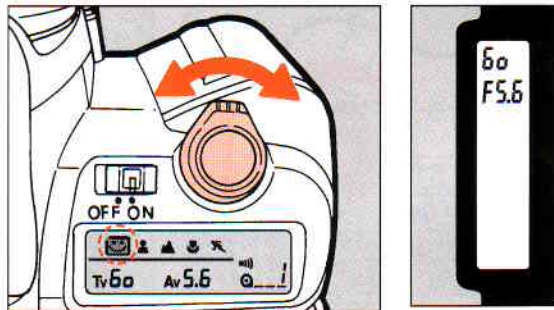

### Green Operation Mode



For easy picture taking, use the Green Operation Mode. You simply depress the shutter release button. The camera selects the best combination of aperture and shutter speed setting.

### How to set

Set the mode dial to .

Move the select switch until  superimposes on .

- When the shutter release button is depressed half-way, the shutter speed and aperture setting are displayed in the viewfinder and on the LCD panel.

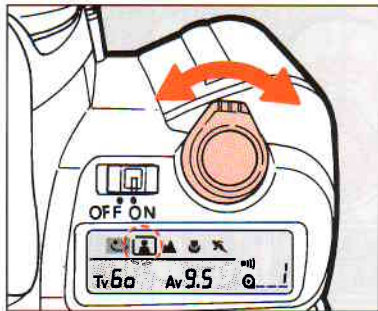

## Portrait Program Mode



This mode is suitable for taking portrait photography.

### How to set

Set the mode dial to .

Move the select switch until  superimposes on .

- When the shutter release button is depressed halfway down, the shutter speed and aperture setting are displayed in the viewfinder and on the LCD panel.

In this mode, the telephoto lens produces a portrait in crisp focus against the out-of-focus background, while the wide angle lens enables you to shoot group photography or snapshots in sharp and clear focus with the extended depth-of-field.

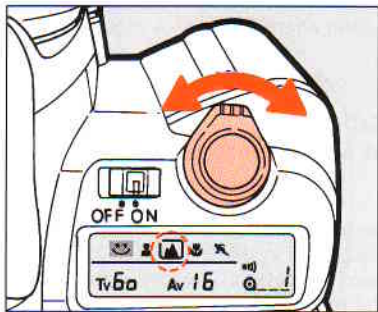

## Landscape Program Mode



This mode is ideal for landscape photography and scenic snapshots.

### How to set

Set the mode dial to .

Move the select switch until  superimposes on .

- When the shutter release button is depressed halfway down, the shutter speed and aperture setting are also displayed in the viewfinder and on the LCD panel.





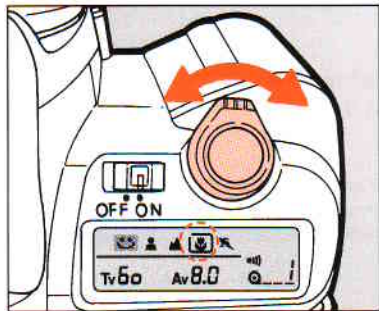

## Close-up Program Mode



This mode is useful for close-up photography. This mode favors smaller apertures to maximize the depth of field, ensuring sharp focus of a close-up subject.

### How to set

Set the mode dial to .

Move the select switch until  superimposes on .

- When the shutter release button is depressed halfway down,  is displayed in the viewfinder. The shutter speed and aperture setting are also displayed in the viewfinder and on the LCD panel.



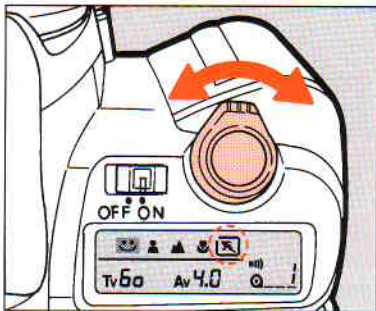

## Action Program Mode



This mode selects a faster shutter speed to capture a moving subject.

### How to set

Set the mode dial to .

Move the select switch until  superimposes on .

- When the shutter release button is depressed halfway down, the shutter speed and aperture setting are displayed in the viewfinder and on the LCD panel.

This mode freezes the action and prevent blurred images. This mode is especially convenient for active photography. It is also suitable for portraits with blurred background.