

Thank you for using our products.
INSTALLATION INSTRUCTIONS
SERIES HS4-24 MULTI-CANDELA FOUR WIRE APPLIANCES
(WALL AND CEILING MOUNT VERSIONS)

Use this product according to this instruction manual. Please keep this instruction manual for future reference.

GENERAL:

Series HS4-24MCW and HS4-24MCC Multi-Candela Horn Strobe provides four selectable candela settings (15, 30, 75, 110 and 15/30/75/95 respectively). These models allow for independent operation of the strobe circuit and the horn circuit. It is the ideal choice for retrofit applications as well as new installations. The HS4 appliance is UL Listed under Standard 1971 for Signaling Appliances for the Hearing Impaired and UL Standard 464 for Audible Signal Appliances. The HS4-24MCW is also ULC Listed under Standard CAN/ULC-S526-02 for Visual Signaling Appliances and Standard CAN/ULC-S525-99 for Audible Signaling Appliances for Fire Alarm Systems. It is listed for indoor use only and can be mounted to double-gang, 4" backbox, 100mm European backbox or SHBB surface backbox. This appliance is listed for wall mounting and ceiling mounting (See wiring and mounting information). The HS4 appliance uses a xenon flashtube with solid state circuitry enclosed in a polycarbonate lens to provide maximum visibility and reliability for effective visible signaling.

The horn portion of the HS4 appliance can be field set to provide either a continuous horn when connected directly to the fire alarm control panel (FACP), or a synchronized code 3 horn when used in conjunction with the Sync Module (SM), Dual Sync Module (DSM) or Wheelock power supplies. The horn can be field set to provide either high (HI) dBA, medium (MED) dBA or low (LO) dBA sound output.

NOTE: The Code 3 temporal pattern (1/2 second on, 1/2 second off, 1/2 second on, 1/2 second off, 1-1/2 off and repeat) is specified by ANSI and NFPA 72 for standard emergency evacuation signaling. The Code 3 Horn should be used only for fire evacuation signaling and not for any other purpose.

The HS4 is designed for use with either filtered DC or unfiltered full-wave-rectified (FWR) input voltage. All inputs are polarized for compatibility with standard reverse polarity supervision of circuit wiring by an FACP.

NOTE: All Canadian Installations should be in accordance with the Canadian Standard for the Installation of Fire Alarm Systems – CAN/ULC-S524-01 and Canadian Electrical Code, Part 1. Final acceptance is subject to authorities having jurisdiction (AHJ).

⚠ WARNING: PLEASE READ THESE INSTRUCTIONS CAREFULLY BEFORE USING THIS PRODUCT. FAILURE TO COMPLY WITH ANY OF THE FOLLOWING INSTRUCTIONS, CAUTIONS AND WARNINGS COULD RESULT IN IMPROPER APPLICATION, CANDELA SETTING, INSTALLATION AND/OR OPERATION OF THESE PRODUCTS IN AN EMERGENCY SITUATION, WHICH COULD RESULT IN PROPERTY DAMAGE AND SERIOUS INJURY OR DEATH TO YOU AND/OR OTHERS.

SPECIFICATIONS:

Table 1: UL/ULC Listed Models and Ratings

Model	Regulate Voltage (VDC/VRMS)	Voltage Range Limit Per UL 1971 (VDC/VRMS)	Voltage Range Per CAN/ULC-S526-02 (VDC/VRMS)	Strobe Candela (cd)
HS4-24MCW	24	16.0-33.0	20.0-31.0	15/30/75/110
HS4-24MCC	24	16.0-33.0	-	15/30/75/95

NOTE: HS4-24MCC IS NOT A ULC APPROVED PRODUCT

Table 2: dBA Sound Output for 24VDC Models

Description	Volume	Reverberant Per UL 464			Anechoic dBA @ 10 Ft. Per CAN/ULC-S525-99		
		16.0VDC	24VDC	33.0VDC	20.0VDC	24VDC	31.0VDC
Continuous Horn	Low	80	83	86	88	90	91
	Medium	85	88	91	93	95	97
	High	88	91	93	97	99	100
Code 3 Horn	Low	75	79	82	88	90	91
	Medium	80	84	86	93	95	97
	High	84	87	89	97	99	100

Figure 1: ULC Directional Characteristics

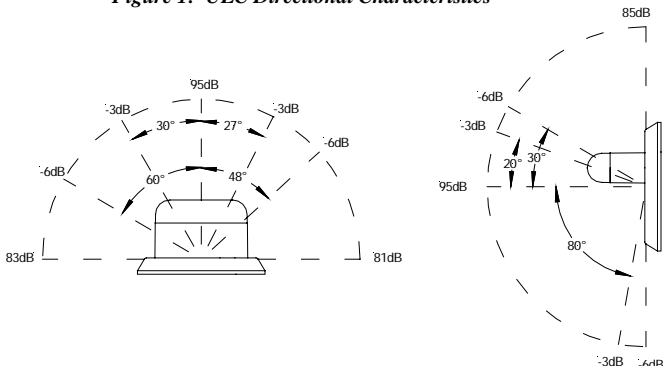

NOTES:

1. The strobe will produce 1 flash per second over the "Regulated Voltage" range.
2. This horn/strobe model meets the required light distribution patterns defined in UL 1971 and ULC-S526-02.
3. This model is UL/ULC Listed for indoor use with a temperature range of +32°F to +120°F (0°C to +49°C) and maximum humidity of 93% ± 2% RH. The effect of shipping and storage temperatures shall not adversely affect the performance of the appliance when it is stored in the original cartons and not subjected to misuse or abuse.

When calculating the total current: Use Tables 3, 3A & 3B to determine the highest value of "RMS Current" for an individual HS4 then multiply the value by the total number of HS4 Appliances. Be sure to add the currents for any other appliances powered by the same source and to include any required safety factors.

NOTE: The maximum number of strobes on a single notification appliance circuit shall not exceed 50.

CAUTION: These notification appliances are UL Listed as “Regulated”. They are intended to be used with FACP’s whose notification circuits are UL Listed as “Regulated.” These appliances shall not be used on UL Listed “Special Application” notification circuits unless the appliances are identified to be compatible in the installation instructions of the FACP or unless the FACP is identified to be compatible in this instruction manual.

WARNING: CANDELA SETTING WILL DETERMINE THE CURRENT DRAW OF THE PRODUCT.

Table 3: Current Ratings (Horn Only)				
Maximum RMS Current Amps				
Voltage		Lo	Med	Hi
DC	16-33VDC	0.027	0.068	0.110
FWR	16-33VRMS	0.041	0.050	0.094

Table 3A: HS4-24MCW Current Ratings (Strobe Only)					
Maximum RMS Current Amps					
Voltage		15cd	30cd	75cd	110cd
DC	16-33VDC	0.060	0.092	0.165	0.220
FWR	16-33VRMS	0.102	0.155	0.253	0.347

Table 3B: HS4-24MCC Current Ratings (Strobe Only)					
Maximum RMS Current Amps					
Voltage		15cd	30cd	75cd	95cd
DC	16-33VDC	0.065	0.105	0.189	0.249
FWR	16-33VRMS	0.110	0.170	0.280	0.375

WARNING: THESE APPLIANCES WERE TESTED TO THE REGULATED VOLTAGE LIMITS OF 16.0-33.0 VOLTS FOR 24V MODELS USING FILTERED DC OR UNFILTERED FULL-WAVE-RECTIFIED VOLTAGE. DO NOT APPLY VOLTAGE OUTSIDE OF THIS RANGE.

WARNING: CHECK THE MINIMUM AND MAXIMUM OUTPUT OF THE POWER SUPPLY AND STANDBY BATTERY AND SUBTRACT THE VOLTAGE DROP FROM THE CIRCUIT WIRING RESISTANCE TO DETERMINE THE APPLIED VOLTAGE TO THE STROBES. THE MAXIMUM WIRE IMPEDANCE BETWEEN STROBES SHALL NOT EXCEED 35 OHMS.

WARNING: MAKE SURE THAT THE TOTAL RMS CURRENT REQUIRED BY ALL APPLIANCES THAT ARE CONNECTED TO THE SYSTEM’S PRIMARY AND SECONDARY POWER SOURCES, APPLIANCE CIRCUITS, SM, DSM SYNC MODULES AND WHEELLOCK POWER SUPPLIES DOES NOT EXCEED THE POWER SOURCES’ RATED CAPACITY OR THE CURRENT RATINGS OF ANY FUSES ON THE CIRCUITS TO WHICH THESE APPLIANCES ARE WIRED. OVERLOADING POWER SOURCES OR EXCEEDING FUSE RATINGS COULD RESULT IN LOSS OF POWER AND FAILURE TO ALERT OCCUPANTS DURING AN EMERGENCY, WHICH COULD RESULT IN PROPERTY DAMAGE AND SERIOUS INJURY OR DEATH TO YOU AND/OR OTHERS.

CAUTION: The strobe is not designed to be used on coded systems in which the applied voltage is cycled on and off.

NOTE: The horn circuit is compatible with coded systems only if the unit is wired for independent horn and strobe operation per figure 4.

SOUND OUTPUT (SPL) AND CANDELA SETTINGS:

Figure 2: Showing Location of Candela Selector and Jumper Plugs

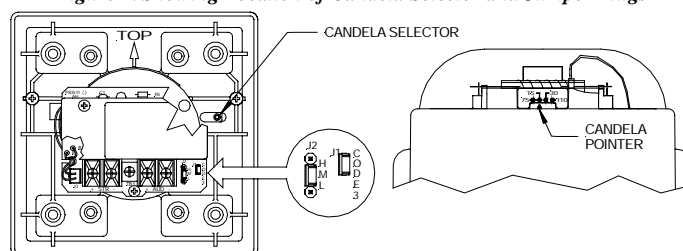

HS4-24MCW shown.

Factory setting for HS4-24MCW and MCC is on 15 candela, Medium dB and Code 3.

WARNING: THE CANDELA SELECT SWITCH MUST BE FIELD SET TO THE REQUIRED CANDELA INTENSITY BEFORE INSTALLATION. WHEN CHANGING THE SETTING OF THE CANDELA SELECT SWITCH, MAKE CERTAIN THAT IT “CLICKS” IN PLACE. AFTER CHANGING THE CANDELA SETTING, THE APPLIANCE MUST BE RETESTED TO VERIFY PROPER OPERATION. IMPROPER SETTING OF THE CANDELA SELECT SWITCH MAY RESULT IN OPERATION AT THE WRONG CANDELA, WHICH COULD RESULT IN A CURRENT DRAW EXCEEDING THE POWER SUPPLY’S CAPACITY.

CAUTION: If these appliances are operated within 15 inches of a person’s ear, they can produce a sound pressure level that exceeds the maximum 120dBA permitted by ADA and OSHA rules. Exposure to such sound levels can result in damage to a person’s hearing.

WARNING: THE HS4 APPLIANCES MUST BE FIELD SET TO THE DESIRED TONE AND dBA SOUND OUTPUT LEVEL BEFORE THEY ARE INSTALLED. THIS IS DONE BY PROPERLY INSERTING JUMPER PLUGS IN ACCORDANCE WITH THESE INSTRUCTIONS. INCORRECT SETTINGS WILL RESULT IN IMPROPER PERFORMANCE, WHICH COULD RESULT IN PROPERTY DAMAGE AND SERIOUS INJURY OR DEATH TO YOU AND/OR OTHERS.

Figure 3: Jumper Plug Settings for High, Medium, Low dB, Code 3 Horn and Continuous Horn Setting.

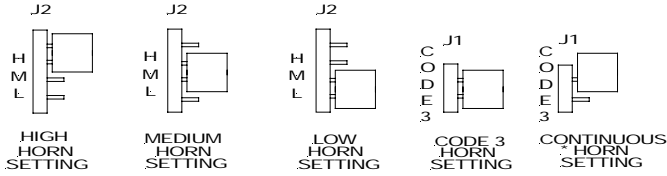

- Use needle nose pliers to pull and properly insert the jumper plug.
- No jumper plug is needed for continuous horn setting. However, it is recommended that the jumper plug be retained in the unit for future use (if needed) as shown in Figure 3.
- The HS4 must be set for Code 3 horn when used with the sync module. Refer to instruction sheets for SM (P83123), DSM (P83177) or Wheelock power supplies for additional information. If the HS4 audible is connected to a coded system, the continuous horn setting must be used

WIRING AND MOUNTING INFORMATION:

Figure 4: Audible signal and strobe operate independently.

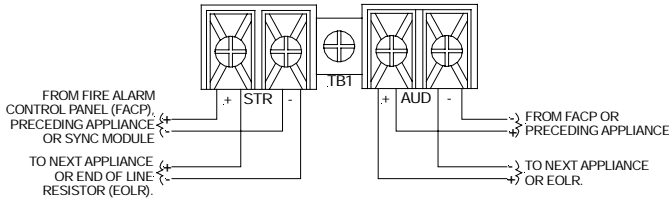
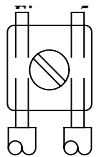
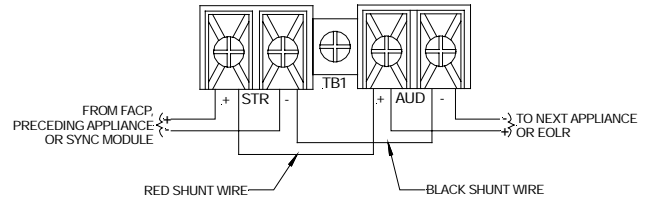
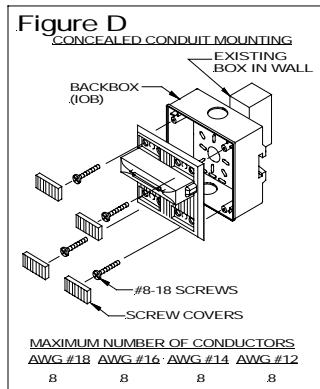
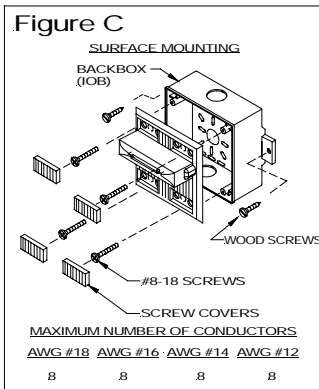
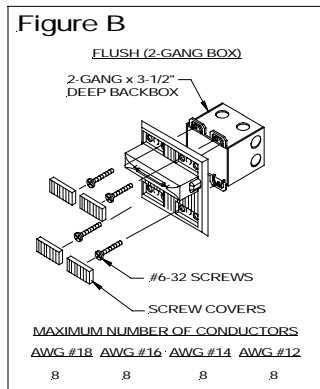
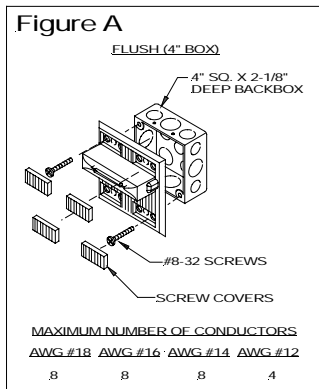

Figure 4A: Audible and strobe operate in unison. Shunt wires are supplied.



- HS4 Appliances have in-out wiring terminals that accepts two #12 to #18 American Wire Gauge (AWG) wires at each screw terminal. Strip leads 3/8" inches for connection to screw terminals.
- Break all in-out wire runs on supervised circuit supervision as shown in Figure 5. The polarity shown in the wiring diagrams is for the operation of the appliances. The polarity is reversed by the FACP during supervision.

CAUTION: The following figures (A-D) show the maximum number of field wires (conductors) that can enter the backbox used with each mounting option. If these limits are exceeded, there may be insufficient space in the backbox to accommodate the field wires and stresses from the wires could damage the product. Check that the installed product will have sufficient clearance and wiring room prior to installing backboxes and conduit, especially if sheathed multiconductor cable or 3/4" conduit fittings are used.



Although the limits shown for each mounting option comply with the National Electrical Code (NEC), Cooper Wheelock recommends use of the largest backbox option shown and the use of approved stranded field wires, whenever possible, to provide additional wiring room for easy installation and minimum stress on the product from wiring.

MOUNTING PROCEDURES:

1. This HS4 model can be flush mounted to a 100mm backbox (Figure A) or double-gang backbox (Figure B). It can also be surface mounted to a indoor/outdoor backbox (Figures C & D). Mounting hardware for each mounting option is supplied.
2. Conduit entrances to the backbox should be selected to provide sufficient wiring clearance for the installed product. Do not pass additional wires (used for other than the signaling appliance) through the backbox. Such additional wires could result in insufficient wiring space for the signaling appliance.
3. When terminating field wires, do not use more lead length than required. Excess lead length could result in insufficient wiring space for the appliance.
4. Use care and proper techniques to position the field wires in the backbox so that they use minimum space and produce minimum stress on the product. This is especially important for stiff, heavy gauge wires and wires with thick insulation or sheathing.
5. Connect field wires to the HS4 terminal block (polarity must be observed). Bend the field wires up 90° at the connection to the terminal block.
6. Carefully push the field wires into the backbox by hand. Press the HS4 to the backbox, verifying that it is seated and aligned correctly.
7. Fasten the HS4 to the backbox using the supplied screws.

⚠ WARNING: THE HS4 APPLIANCE IS A “FIRE ALARM DEVICE – DO NOT PAINT.”

⚠ WARNING: WHEN INSTALLING STROBES IN AN OPEN OFFICE OR OTHER AREAS CONTAINING PARTITIONS OR OTHER VIEWING OBSTRUCTIONS, SPECIAL ATTENTION SHOULD BE GIVEN TO THE LOCATION OF THE STROBES SO THAT THEIR OPERATING EFFECT CAN BE SEEN BY ALL INTENDED VIEWERS, WITH THE INTENSITY, NUMBER, AND TYPE OF STROBES BEING SUFFICIENT TO MAKE SURE THAT THE INTENDED VIEWER IS ALERTED BY PROPER ILLUMINATION, REGARDLESS OF THE VIEWER'S ORIENTATION. FAILURE TO DO SO COULD RESULT IN PROPERTY DAMAGE AND SERIOUS INJURY OR DEATH TO YOU AND/OR OTHERS.

The HS4-24MCW's 110cd setting is Listed for use in sleeping or non-sleeping areas when installed in accordance with appropriate NFPA Standards and the AHJ.

⚠ WARNING: IF 110 CANDELA STROBES ARE INSTALLED IN SLEEPING AREAS, THEY SHOULD BE WALL MOUNTED AT LEAST 24" BELOW THE CEILING AS FOLLOWS: (1) THE ON-AXIS (CENTER OF LENS) LIGHT OUTPUT SHOULD BE DIRECTED AT THE EYELIDS OF THE SLEEPING PERSON, E.G. PILLOW END OF BED, BED HEAD; (2) NO PART OF THE BED SHALL BE MORE THAN SIXTEEN FEET FROM THE STROBE NOTIFICATION APPLIANCE. INSTALLERS MUST ADVISE OWNERS AND OPERATORS OF BUILDINGS WITH SLEEPING OCCUPANTS, E.G. HOTELS AND MOTELS, TO WARN GUESTS, RESIDENTS AND EMPLOYEES TO NOT MOVE THE BED LOCATION TO A POSITION VIOLATING POINTS (1) AND (2) ABOVE OR SERIOUS INJURY AND/OR LOSS OF LIFE MAY OCCUR DURING A FIRE EMERGENCY.

⚠ WARNING: A SMALL POSSIBILITY EXISTS THAT THE USE OF MULTIPLE STROBES WITHIN A PERSON'S FIELD OF VIEW, UNDER CERTAIN CIRCUMSTANCES, MIGHT INDUCE A PHOTO-SENSITIVE RESPONSE IN PERSONS WITH EPILEPSY. STROBE REFLECTIONS IN A GLASS OR MIRRORRED SURFACE MIGHT ALSO INDUCE SUCH A RESPONSE. TO MINIMIZE THIS POSSIBLE HAZARD, COOPER WHEELLOCK STRONGLY RECOMMENDS THAT THE STROBES INSTALLED SHOULD NOT PRESENT A COMPOSITE FLASH RATE IN THE FIELD OF VIEW WHICH EXCEEDS FIVE Hz AT THE OPERATING VOLTAGE OF THE STROBES. COOPER WHEELLOCK ALSO STRONGLY RECOMMENDS THAT THE INTENSITY AND COMPOSITE FLASH RATE OF INSTALLED STROBES COMPLY WITH LEVELS ESTABLISHED BY APPLICABLE LAWS, STANDARDS, REGULATIONS, CODES AND GUIDELINES.

NOTE: NFPA 72/ANSI 117.1 conform to ADAAG Equivalent Facilitation Guidelines in using fewer, higher intensity strobes within the same protected area.

⚠ CAUTION: Check the installation instructions of the manufacturers of other equipment used in the system for any guidelines or restrictions on wiring and/or locating Notification Appliance Circuits (NAC) and notification appliances. Some system communication circuits and/or audio circuits, for example, may require special precautions to assure electrical noise immunity (e.g. audio crosstalk).

NOTE: This equipment has been tested and found to comply with the limits for a Class B digital appliance, pursuant to Part 15 of the FCC Rules. These limits are designed to provide reasonable protection against harmful interference in residential installation. This equipment generates, uses and can radiate radio frequency energy and, if not installed and used in accordance with the instructions, may cause harmful interference to radio communications. However, there is no guarantee that interference will not occur in a particular installation. If this equipment does cause harmful interference to radio or television reception, which can be determined by turning the equipment off and on, the user is encouraged to try to correct the interference by one or more of the following measures: 1) Reorient or relocate the receiving antenna, 2) Increase the separation between the equipment and receiver, 3) Connect the equipment into an outlet on a circuit different from that to which the receiver is connected, and 4) Consult the dealer or an experienced radio/TV technician for help.

The Series HS4 products and these instructions are copyrighted by Cooper Wheelock and the Series HS4 products contain proprietary, confidential and trade secrets of Cooper Wheelock. No part of the Series HS4 products and these instructions may be photocopied, printed or reproduced in any form or modified, adapted, changed or enhanced, or converted to another programming language, or used to create updated, related or derivative works, without the prior written consent of Cooper Wheelock. No part of the Series HS4 products shall be decomposed, disassembled or reverse engineered.

ANY MATERIAL EXTRAPOLATED FROM THIS DOCUMENT OR FROM COOPER WHEELLOCK MANUALS OR OTHER DOCUMENTS DESCRIBING THE PRODUCT FOR USE IN PROMOTIONAL OR ADVERTISING CLAIMS, OR FOR ANY OTHER USE, INCLUDING DESCRIPTION OF THE PRODUCT'S APPLICATION, OPERATION, INSTALLATION AND TESTING IS USED AT THE SOLE RISK OF THE USER AND COOPER WHEELLOCK WILL NOT HAVE ANY LIABILITY FOR SUCH USE.

Limited Warranty

Cooper Wheelock, Inc. products must be used within their published specifications and must be PROPERLY specified, applied, installed, operated, maintained, and operationally tested in accordance with these instructions at the time of installation and at least twice a year or more often in accordance with local, state and federal codes, regulations and laws. Specification, application, installation, operation, maintenance, and testing must be performed by qualified personnel for proper operation in accordance with all of the latest National Fire Protection Association (NFPA), Underwriters' Laboratories (UL), Underwriters' Laboratories of Canada (ULC), National Electrical Code (NEC), Occupational Safety and Health Administration (OSHA), local, state, county, province, district, federal and other applicable building and fire standards, guidelines, regulations, laws and codes including, but not limited to, all appendices and amendments and the requirements of the local authority having jurisdiction (AHJ). Cooper Wheelock, Inc. products when properly specified, applied, installed, operated, maintained, and operationally tested as provided above are warranted against mechanical and electrical defects for a period of three years from date of manufacture (as determined by date code). Correction of defects by Cooper Wheelock, Inc providing repairs or a replacement shall be at Cooper Wheelock, Inc.'s sole discretion and shall constitute fulfillment of all warranty obligations. The foregoing limited warranty shall immediately terminate in the event any part not furnished by Cooper Wheelock, Inc. is installed in the product. The foregoing limited warranty specifically excludes any software required for the operation of or included in a product. COOPER WHEELOCK, INC. MAKES NO REPRESENTATION OR WARRANTY OF ANY OTHER KIND, EXPRESS, IMPLIED OR STATUTORY WHETHER AS TO MERCHANTABILITY, FITNESS FOR A PARTICULAR PURPOSE OR ANY OTHER MATTER.

Users are solely responsible for determining whether a product is suitable for the user's purposes, or whether it will achieve the user's intended results. There is no warranty against damage resulting from misapplication, improper specification, abuse, accident, or other operating conditions beyond Cooper Wheelock, Inc.'s control.

Some Cooper Wheelock, Inc. products contain software. With respect to those products, Cooper Wheelock, Inc. does not warranty that the operation of the software will be uninterrupted or error-free or that the software will meet any other standard of performance, or that the functions or performance of the software will meet the user's requirements. Cooper Wheelock, Inc. shall not be liable for any delays, breakdowns, interruptions, loss, destruction, alteration, or other problems in the use of a product arising out of or caused by the software.

The liability of Cooper Wheelock, Inc. arising out of the supplying of a product, or its use, whether based on warranty, negligence, or otherwise, shall not in any case exceed the cost of correcting defects as stated in the limited warranty and upon expiration of the warranty period all such liability shall terminate. Cooper Wheelock, Inc. is not liable for labor costs incurred in removal, reinstallation, or for damage of any type whatsoever, including but not limited to, loss of profit or incidental or consequential damages. The foregoing shall constitute the sole remedy of the purchaser and the exclusive liability of Cooper Wheelock, Inc.

In no case will Cooper Wheelock, Inc.'s liability exceed the purchase price paid for a product.

Limitation of Liability

Cooper Wheelock, Inc.'s liability on any claim of any kind, including negligence, breach of warranty, or otherwise, for any loss or damage resulting from, arising out of, or connected with any contract, or from the manufacture, sale, delivery, resale, repair or use of any product shall be limited to the price applicable to the product or part thereof which gives rise to the claim. Cooper Wheelock, Inc.'s liability on any claim of any kind shall cease immediately upon the installation in the product of any part not furnished by Cooper Wheelock, Inc. In no event shall Cooper Wheelock, Inc. be liable for any claim of any kind unless it is proven that our product was a direct cause of such claim. **FURTHER, IN NO EVENT, INCLUDING IN THE CASE OF A CLAIM OF NEGLIGENCE, SHALL COOPER WHEELOCK, INC. BE LIABLE FOR INCIDENTAL, INDIRECT, SPECIAL OR CONSEQUENTIAL DAMAGES.** Some states do not allow the exclusion or limitation of incidental or consequential damages, so the preceding limitation may not apply to all purchasers.