

**Series MDV-2  
Modular Digital VoiceLink  
Operation and Installation  
Manual**

**wheelock**

INC.

273 Branchport Avenue  
Long Branch, NJ 07740  
Telephone: (800) 631-2148  
Fax: 732-222-8707  
[www.wheelockinc.com](http://www.wheelockinc.com)

**THANK YOU FOR PURCHASING OUR PRODUCTS. USE THIS PRODUCT ACCORDING TO THIS INSTRUCTION MANUAL. PLEASE KEEP THIS INSTRUCTION MANUAL FOR FUTURE REFERENCE.**

**ANY MATERIAL EXTRAPOLATED FROM THIS DOCUMENT OR FROM WHEELLOCK MANUALS OR OTHER DOCUMENTS DESCRIBING THE PRODUCT FOR USE IN PROMOTIONAL OR ADVERTISING CLAIMS, OR FOR ANY OTHER USE, INCLUDING DESCRIPTION OF THE PRODUCT'S APPLICATION, OPERATION, INSTALLATION AND TESTING IS USED AT THE SOLE RISK OF THE USER AND WHEELLOCK WILL NOT HAVE ANY LIABILITY FOR SUCH USE.**

## **Conventions Used in This Manual**

This manual uses the following conventions for cautions and warnings.



**CAUTION:**

Indicates a potentially hazardous situation which, if not avoided, could result in minor or moderate injury. It may also be used to alert against unsafe practices.



**WARNING:**

**INDICATES A POTENTIALLY HAZARDOUS SITUATION WHICH, IF NOT AVOIDED, COULD RESULT IN PROPERTY DAMAGE AND SERIOUS PERSONAL INJURY OR DEATH.**


Copyright 2005 Wheelock, Inc. All rights reserved.

P83452  
MDV-2 Manual  
Rev. C February 2005

## **Preface**

The Series MDV-2 provides playback capability for pre-recorded messages. The Series MDV-2 does not sense an emergency condition or hazardous fires, but is only a part of a system that does sense such conditions. The Series MDV-2, when activated by a control panel, provides a pre-recorded tone and/or voice message to an audio system. When used as part of a protective signaling system, the Series MDV-2 must be properly connected to a compatible control panel that has been approved by a nationally recognized testing laboratory ("LISTED") and/or a LISTED compatible audio system with LISTED compatible notification appliances for proper operation.


PERSONNEL PROPERLY QUALIFIED IN THE APPLICATION AND USE OF LIFE SAFETY EQUIPMENT ("QUALIFIED PERSONNEL") MUST READ THIS MANUAL CAREFULLY BEFORE PERFORMING ACTIONS TO SPECIFY, APPLY, INSTALL, MAINTAIN AND OPERATIONALLY TEST SERIES MDV-2 PRODUCTS IN ACCORDANCE WITH THE INSTRUCTIONS IN THIS MANUAL.

 **WARNING:** IF SAFETY PRECAUTIONS, INSTALLATION AND TESTING INSTRUCTIONS ARE NOT PERFORMED PROPERLY, THE SERIES MDV-2 MAY NOT OPERATE IN AN EMERGENCY SITUATION WHICH COULD RESULT IN PROPERTY DAMAGE, SERIOUS INJURY OR DEATH TO YOU AND/OR OTHERS.

- **DO NOT** assume any installation, operation and testing details not shown in this manual.
- The Series MDV-2 should only be operated with **covers** properly **in place**.
- **KEEP** this manual **WITH THE SERIES MDV-2 FOR FUTURE REFERENCE** for the life of the system and make it available to all qualified personnel who operate, test, maintain, or service the Series MDV-2. We strongly recommend that such personnel read and understand the entire manual.


The Series MDV-2 WILL NOT WORK WITHOUT POWER. The Series MDV-2 is powered by the protective signaling system. If power is cut off for any reason, the Series MDV-2 will not provide the desired tone and/or voice warning. Backup power supplies are recommended for protective signaling systems.

**WHEELLOCK EXPRESSLY DISCLAIMS ALL LIABILITY FOR THE CONTENT, CLARITY AND LANGUAGES OF, AND OUTPUT CHANNEL AND PRIORITY LEVEL ASSIGNED TO, ANY AND ALL MESSAGES. IT IS ESSENTIAL THAT YOU HAVE MESSAGE CONTENT AND LANGUAGE, SEQUENCE, OUTPUT CHANNEL AND PRIORITY ASSIGNMENTS REVIEWED AND APPROVED BY QUALIFIED LEGAL AND SAFETY ADVISORS, QUALIFIED REPRESENTATIVE(S) OF OWNER(S) AND USER(S), AND AUTHORITIES HAVING JURISDICTION.**

 **CAUTION:** The Series MDV-2 printed circuit boards are sensitive to static electricity and have delicate components mounted on them. Before handling either a board or any component on a board, discharge any static electricity from your body by touching a grounded object such as a metal screw which is connected to earth ground. Handle the board by its edges, and be careful not to twist or flex it. The Series MDV-2 is to be installed in a static free area and the user is to properly attach grounded wrist straps before touching any static sensitive areas. After handling Series MDV-2 printed circuit boards, the Series MDV-2 should be tested in accordance with the "System Checkout" section to verify that the printed circuit boards are undamaged and functioning properly.

COMPLY WITH ALL OF THE LATEST APPLICABLE CODES, REGULATIONS, LAWS, STANDARDS, GUIDELINES.

For emergency, hazardous, security, life safety and fire protective signaling system applications, the Series MDV-2 must be used within their published specifications and only with a LISTED compatible control panel and LISTED compatible audio system in accordance with sound engineering judgment and the instructions of the manufacturer and in accordance with local, state and federal codes, regulations and laws. The Series MDV-2 must be PROPERLY specified, applied, installed, operated, maintained and operationally tested in accordance with these instructions at the time of installation and at least twice a year or more often as required by local, state and federal codes, regulations and laws. Installation, testing and maintenance must be performed by qualified personnel for proper operation in accordance with all of the latest National Fire Protection Association (NFPA), Underwriters' Laboratories (UL), National Electrical Code (NEC), Occupational Safety and Health Administration (OSHA), local, state, county, province, district, federal and other applicable building and fire standards, guidelines, regulations, laws and codes including, but not limited to, all appendices and amendments and the requirements of the local authority having jurisdiction (AHJ).

 **WARNING:** IF THE PROTECTIVE SIGNALING SYSTEM SOUNDS AND/OR FLASHES, IT IS A WARNING OF A POSSIBLY SERIOUS SITUATION AND REQUIRES YOUR IMMEDIATE ATTENTION.

**NOTE:** This equipment has been tested and found to comply with the limits for a Class A digital device pursuant to Part 15 of FCC Rules. These limits are designed to provide reasonable protection against harmful interference when this equipment is operated in a commercial environment. This equipment generates, uses, and can radiate radio frequency energy and, if not installed and used in accordance with the instruction manual, may cause harmful interference to radio communications. Operation of this equipment in a residential area is likely to cause harmful interference in which case the user will be required to correct the interference at his/her own expense.

For the Series MDV-2 to properly operate, it must be properly connected to a listed compatible and properly operating control panel and audio system, or to a listed compatible and properly operating audio system, that controls its activation and provides proper voltage and current. The operation and electrical ratings of such control panel and audio system, or such audio system, must be compatible with the Series MDV-2, and all equipment must be properly interconnected and operating. The installer must check compatibility before installation; otherwise, the Series MDV-2 and/or the control panel and/or the audio system may be damaged and/or fail to operate in an emergency situation.

Each manufacturer's fire alarm control panel, audio system, and notification appliance operates differently and has different features. Before specifying, installing, operating, testing, maintaining or servicing a system, carefully read the installation, operation and testing manual for each piece of equipment and applicable codes.

Request that the local authority having jurisdiction inspect the proposed placement of the notification appliances and receive their approval.

The output of the audio system may not be heard in all cases. Sound can be blocked or reduced by walls, doors, carpeting, wall covering, furniture, insulation, bed coverings, and other obstacles that may temporarily or permanently impede the output of the audio system. Sound is also reduced by distance and masked by background noise. The output of the audio system may not be sufficient to alert all occupants, especially those who are asleep, those who are hearing-impaired, those who are wearing devices that plug or cover the ears, and those who have recently used drugs or alcohol. The output of the audio system may not be heard by an alert person if the output device is placed in an area which is isolated by a closed door, or is located on a different floor from the person in a hazardous situation or is placed too far away to be heard over ambient noise such as, but not limited to, running water, traffic, air conditioners, machinery or musical appliances.



**WARNING: AUDIBLE SIGNALS MAY MASK MEDICAL EQUIPMENT MONITORING ALARMS. WHERE MEDICAL EQUIPMENT MONITORING ALARMS ARE IN USE, DO NOT USE AUDIBLE SIGNALS; PROVIDE VISUAL NOTIFICATION APPLIANCES IN HIGHLY VISIBLE LOCATIONS.**

If audible tones and/or voice messages cannot be readily heard and understood clearly within the protected areas as intended, it is necessary to increase the number and/or sound output intensity of speakers within those areas so that they are heard and understood clearly when activated.

Notification equipment cannot last forever. Even though the Series MDV-2 is expected to last up to ten years, any of its parts or components could fail before then. Therefore testing of the entire protective signaling system, including the Series MDV-2, all notification equipment, as well as all messages and their output channel, and priority assignment, must be conducted at least twice each year, or more often as required by local, state and federal codes, regulations and laws, by qualified personnel. If the notification equipment is not working properly, immediately contact the installer and have all/any problems corrected immediately. Malfunctioning components should be replaced immediately. Do not attempt to repair malfunctioning components. Malfunctioning components should be returned for factory repair or replacement. In the event you cannot contact the installer, contact the manufacturer.



**WARNING:**

**THERE ARE CERTAIN HARDWARE FUNCTIONS ON THE SERIES MDV-2 WHICH ARE NOT SUPERVISED. IF ANY SUCH HARDWARE FUNCTIONS FAIL, THE SERIES MDV-2 MAY NOT PROVIDE THE INTENDED WARNING AND/OR NOT INDICATE A TROUBLE CONDITION.**

**THE FOLLOWING HARDWARE FAILURES WOULD PREVENT THE SERIES MDV-2 FROM PROVIDING THE INTENDED WARNING:**

- 1. THE "SHORT CIRCUIT" DETECTION CIRCUITRY FOR ANY ONE OR ALL OF THE EIGHT CONTACT INPUTS.**
- 2. THE SERIAL PORT RECEIVER.**
- 3. THE PLAY CONTACT FOR EACH OF THE FOUR OUTPUT CHANNELS.**

**THE FOLLOWING HARDWARE FAILURES WOULD PREVENT THE SERIES MDV-2 FROM INDICATING A TROUBLE CONDITION.**

- 1. THE AUDIO SUPERVISION CIRCUITRY FOR EACH OF THE TWO OUTPUT CHANNELS.**
- 2. THE STATUS CONTACT.**

**THESE HARDWARE FUNCTIONS MUST BE PERIODICALLY CHECKED FOR PROPER OPERATION. REFER TO PERIODIC TESTING SECTION FOR RECOMMENDED TESTING PROCEDURES.**

Additional copies of this manual may be obtained from the manufacturer.

# CONTENTS

	Page
Introduction.....	8
Operation.....	10
Message Memory.....	10
Input and Output Options.....	11
Message Files.....	11
Output Channels.....	13
File Priority.....	13
Acknowledge Playing Files.....	13
Reset Playing Files.....	13
Playing Files.....	14
System Pause.....	14
Supervision.....	14
Standby Battery Calculations.....	15
Installation.....	16
Wiring Guidelines.....	17
Mounting.....	17
Grounding.....	19
Field Wiring.....	19
Field Wiring Checkout.....	23
System Checkout.....	24
Ground Fault Detection Sensitivity Adjustment.....	24
Troubleshooting.....	25
Procedures A, B, C.....	26
Procedures D, E (not used), F.....	27
Procedures G, H.....	28
Periodic Testing.....	29
Technical Specifications.....	30
Glossary.....	32
Limited Warranty.....	33
Limitation of Liability.....	33
Appendix A. Standard Protocol Description (RS-232).....	A-1

# List of Figures

Figure	1	Basic Capabilities Of The Series MDV-2 Products.....	9
Figure	2	Top View of Message Memory EPROM.....	10
Figure	3	Series MDV-2 Mounting.....	18
Figure	4	Dry Contact Input Wiring.....	20
Figure	5	Audio Output/Music Input/Channel Playing Wiring.....	21
Figure	6	Input Voltage and Status Contact Wiring.....	21
Figure	7	Series MDV-2 Board Layout.....	22
Figure	8	RS-232 Port Pin Connection.....	23

# Introduction

Wheelock's Modular Digital VoiceLink (MDV-2) provides unique storage, and playback capabilities of digitally stored messages and tones for the creation of versatile and automatic announcement systems. Figure 1 illustrates the basic capabilities of the Series MDV-2.

The Series MDV-2 plays pre-recorded voice, tones, or other sounds through amplification equipment (not supplied with the Series MDV-2) when instructed to do so by a contact closure or an instruction over a serial link from other equipment. Custom recording and programming is available from Wheelock.

This manual describes the Series MDV-2 which features:

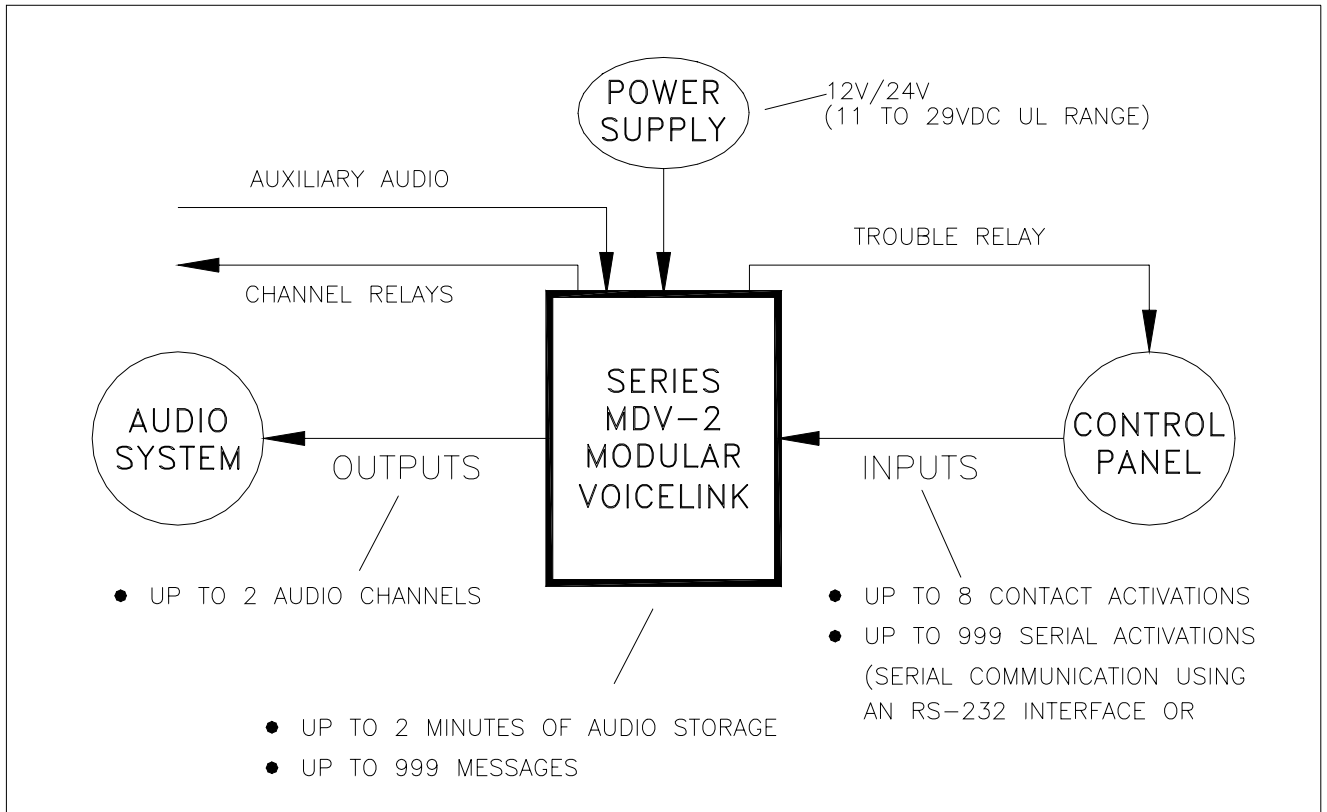
- Up to 2 minutes of audio storage in non-volatile, UV-erasable EPROM (see "EPROM" definition in glossary) memory.
- Selective activation of up to 8 message files using contact closures or open collector transistor switching.
- Selective activation of up to 999 message files through the optional serial port.
- Field Upgradable.
- Up to 5 levels of message file priority assignments, with the two lowest priority levels being acknowledgeable.
- Up to 2 audio output channels.
- Supervision of internal operations with trouble diagnosis and notification.
- Serial communication supervision and optional verification of serial commands with a trouble indication if an error is detected.
- An optional ground fault detection feature.

**A PREPROGRAMMED SERIES MDV-2 MUST BE PROPERLY INSTALLED AND CONNECTED TO A COMPATIBLE CONTROL PANEL, AUDIO SYSTEM AND A POWER SUPPLY TO FUNCTION IN A VOICE ANNOUNCEMENT SYSTEM. THE SERIES MDV-2 OPERATES ONLY WITH REGULATED AND FILTERED DC VOLTAGE, NOT FULL-WAVE-RECTIFIED VOLTAGE.**

The control panel can range from simple push-buttons or detectors that provide contact closures to activate Series MDV-2 files to sophisticated, computer-based control panels that address Series MDV-2 files through an optional serial port. Similarly, the audio system can range from an amplified speaker to a large, multi-channel audio distribution system that can also be integrated with a zoned telephone paging system. Wheelock offers a wide line of audio equipment to configure such systems.

Wheelock models; DV-100, DV-200, MDV-2, DX-100, DX-200, MDX-2 and DV-EM are UL 864 approved for use with Fire Alarm Control Panels (FACP). The above models are used as accessory control units in UL 864 listed protective signaling systems. All models have an operating voltage range of 11.0-29.0VDC. All are operated by a serial port or contact closure with an adjustable output from 0.5-2.0VRMS.





**Figure 1.**  
**Basic Capabilities Of The Series MDV-2**

# Operation

This chapter describes the operating characteristics of the Series MDV-2. Included is information about the following Series MDV-2 features:

- Message Memory
- Input and Output Options
- Message Files
- Output Channels
- File Priority
- Acknowledge Playing Files
- Reset Playing Files
- Playing Files
- System Pause
- Supervision
- Standby Battery Calculations

## Message Memory

The Series MDV-2 is a playback-only unit and has no recording capability. The Series MDV-2 must be pre-programmed by Wheelock or a trained technician.

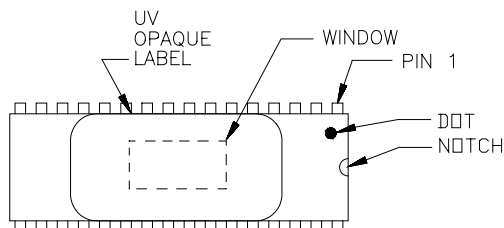
The Series MDV-2 has the ability to store up to two minutes of audio. The audio is stored digitally on up to two memory integrated circuit ("I.C.") chips. Each memory I.C. can store up to one minute of audio messages. See Figure 7 for the socket locations S14 and S12 on the Series MDV-2 printed circuit board into which the two memory I.C.'s, U14 and U12 are inserted.

The memory I.C.'s, U14 and U12, are commonly referred to as erasable programmable read only memories ("EPROM's", see EPROM definition in glossary.) The number of memory I.C.'s in the Series MDV-2 will vary between one or two, depending on the number and length of audio messages recorded.

EPROM's are erased by exposure to ultraviolet ("UV") light. UV light is present in light sources such as sunlight and fluorescent lamps. An EPROM must be protected against accidental or premature erasure by covering its window (see Figure 2) with a UV opaque label.

Each EPROM supplied with this module has its window covered with a UV opaque label. An EPROM's label is to be removed only when erasing the EPROM. After an EPROM has been erased, its window must be recovered with a new UV opaque label.

**⚠ WARNING:** EACH EPROM MUST HAVE A UV OPAQUE LABEL PLACED IN PROPER POSITION AS SHOWN IN FIGURE 2. IF THE LABEL IS WORN, TORN, OR OTHERWISE DAMAGED IN ANY WAY THAT WOULD ALLOW UV LIGHT TO PASS THROUGH, STORED MESSAGES CAN BE ERASED. IF STORED MESSAGES ARE ERASED, THEY WILL NOT BE DELIVERED WHEN AND WHERE REQUIRED, AND COULD RESULT IN PROPERTY DAMAGE AND SERIOUS INJURY OR DEATH TO YOU AND/OR OTHERS.



**Figure 2.**  
**Top View Of Message Memory EPROM**

# Input and Output Options

Each Series MDV-2 model includes 8 inputs that can be used to activate file numbers 1 through 8 with a contact closure or an open collector transistor switch across the corresponding input terminals.


**MAKE SURE THAT SERIES MDV-2 OUTPUTS ARE CONNECTED TO A PROPERLY OPERATING, LISTED COMPATIBLE AUDIO SYSTEM SO THAT MESSAGE FILES ASSIGNED TO THAT CHANNEL CAN BE PLAYED.**

The Series MDV-2 can be field upgraded with a serial port, through which up to 999 message files can be activated with digital commands. The contact inputs in the Series MDV-2 can be used along with the serial port. A command is required to start a message, and a second command is required to stop the message. The operation is similar to closing an input contact (start) and then reopening the contact (stop).

Up to two audio output channels are available with the Series MDV-2. (The audio output from each channel of the Series MDV-2 is capacitively coupled through a 1K Ohm resistor and referenced to the system common.) The audio outputs are designed to drive into 600 Ohms or higher. The audio level of each channel is adjustable from -3.8 dBm to +8.2 dBm (0.5 to 2.0 Vrms) (See Figure 7). All Series MDV-2 output channels can be active simultaneously.

## Message Files

All messages are stored in files within the Series MDV-2 memory. Up to 999 message files can be stored. There is no limit on the length of a message file, except for the limit imposed by total memory in the unit (i.e., up to 1 minute per memory I.C.). There are two types of message files: voice files and string files. Voice files are created by storing audio directly into the selected file number. String files are created by storing file numbers of other message files into the selected file number (See "file" and "string" definitions in glossary). Each message file must be assigned a priority level from 1 to 5 (1 is highest, 5 is lowest) and an output channel from 1 to 2. See "Output Channels", "File Priority", and "Playing Files" sections for additional information.

 **WARNING: EACH MESSAGE MUST BE ASSIGNED ITS INTENDED OUTPUT CHANNEL AND PRIORITY LEVEL DURING PROGRAMMING OR THE MESSAGE WILL NOT BE PLAYED WHEN AND WHERE REQUIRED. THIS COULD RESULT IN PROPERTY DAMAGE AND SERIOUS INJURY OR DEATH TO YOU AND/OR OTHERS.**

String files reduce the message memory requirements by allowing many different message files to be created with a relatively small library of voice files that contain common words or phrases and using one or more of the five string file commands. The string file commands are ADD, PAUSE, COMMON REPEAT, FILE REPEAT and END. ADD is used to add a previously created message file to the string. PAUSE is used to add a period of silence to the string. COMMON REPEAT is used to play the next entered file number multiple times. FILE REPEAT is used to play the entire file again a specified number of times after the file has been de-activated.

The following is an example of creating string files from a small library of voice files using the ADD command.

The following voice messages are recorded into the indicated file numbers:

"There is a fire on the"	into file number 100
"First"	into file number 101
"Second"	into file number 102
"Third"	into file number 103
"Floor"	into file number 104

Create three string files as indicated:

File 1:	ADD 100, ADD 101, ADD 104, END
File 2:	ADD 100, ADD 102, ADD 104, END
File 3:	ADD 100, ADD 103, ADD 104, END

When file number 1 is selected to play, "There is a fire on the first floor" will be played. When file number 2 is selected to play, "There is a fire on the second floor" will be played. When file number 3 is selected to play, "There is a fire on the third floor" will be played.

The following is an example of creating string files using the ADD command and the PAUSE command.

The following voice messages are recorded into the indicated file numbers:

“Welcome to Herbie’s” into file number 100  
“Our fish are the freshest in town” into file number 101

Create a string file as follows:

File 1: ADD 100, PAUSE 10 seconds, ADD 101, END

When file number 1 is selected to play, “Welcome to Herbie’s”.....(10 seconds of silence).....“Our fish are the freshest in town” will be played.

The following is an example of creating string files using the ADD command and the COMMON REPEAT command.

The following voice messages are recorded into the indicated file numbers:

“Run” into file number 100  
“to the nearest salesman” into file number 101

Create a string file as follows:

File 1: COMMON REPEAT 3 times, file number 100, ADD 101, END

When file number 1 is selected to play, “Run, Run, Run to the nearest salesman” will be played.

The following is an example of creating string files using the ADD command and the FILE REPEAT command.

The following voice message is recorded into the indicated file number:

“Thank you for buying Wheelock voice products” into file number 100

Create a string file as follows:

File 1: ADD 100, FILE REPEAT 3 times

When file number 1 is selected to play, “Thank you for buying Wheelock voice products” will be played. The file will play continuously as long as the file is activated. After the file is de-activated, the file will play three additional times. A momentary activation will play the message four times. The FILE REPEAT command must be the last item in the string.

## Output Channels

The Series MDV-2 is supplied with one output channel. A second channel may be added. Message files may be programmed to play out either of the two output channels. (When a message file is programmed to play out both output channels, the message will not necessarily play simultaneously on both output channels.)

## File Priority

The priority of a file playing on one channel will not affect the priority of files playing on any other channel. Priority levels are 1 thru 5, 1 being highest, 5 being lowest.

Priority 1 and Priority 2 files WILL interrupt any file with a lower priority that is playing through the same output channel. Priority 3 and Priority 4 files will NOT interrupt lower priority files but will begin playing immediately upon completion of any lower priority file. Any file that is interrupted by a higher priority file before it has completed playing will remain on the channel queue until it is allowed to replay completely.

If two or more files of equal priority are activated, they will play in the sequence in which they are activated.

Priority 4 and Priority 5 files may be acknowledged. Files are acknowledged by the reception of an acknowledge command on the serial port or activation of the acknowledge input. Acknowledged files will play one more time and then be removed from the queue. Dry contact activated files must have their input released and then reactivated to play again.

Files of all priority levels may be reset. Files are reset by the reception of a reset command on the serial port or activation of the reset input. Reset files will stop immediately and are removed from the queue. Dry contact activated files must have their input released and then reactivated to play again. Serial command activated files must have another serial start command transmitted to play again.

**NOTE:** In the United States the latest NFPA guidelines and standards provide that life safety/fire notification alarm tone(s) and voice message(s) are the only alarm tone(s) and message(s) that shall be assigned priority 1 for all Series MDV-2 output channel(s) assigned to either a dedicated life safety/fire alarm protective signaling system or the life safety/fire alarm system portion of an integrated multi-function system.

## Acknowledge Playing Files

All priority 4 and priority 5 files may be acknowledged. Files activated by a dry contact input may be acknowledged by activating the acknowledge dry contact input. Files activated by a serial command may be acknowledged by the serial acknowledge command. Files which have been acknowledged will play one more time and then be removed from the queue. String files which have been programmed with a file repeat will play the number of times selected by the file repeat option and then be removed from the queue. Dry contact activated files which have been acknowledged must have their input released and then reactivated to play again. Serial command activated files which have been acknowledged must have another serial start command transmitted to play again.

Any dry contact input may be selected to be the acknowledge input. An input selected to be the acknowledge input may not be used to activate files to play.

## Reset Playing Files

Files of all priority levels may be reset. Files activated by a dry contact input may be reset by activating the reset dry contact input. Files activated by a serial command may be reset by the serial reset command. Files which have been reset will stop playing immediately and be removed from the queue. Dry contact activated files which have been reset must have their input released and then reactivated to play again. Serial command activated files which have been reset must have another serial command transmitted to play again.

Any dry contact input may be selected to be the reset input. An input selected to be the reset input may not be used to activate files to play or to be the acknowledge input. The reset input feature may be disabled by selecting input 0 to be the reset input.

**NOTE:** Per UL requirement, the reset switch must be located within a locked enclosure.

## Playing Files

The Series MDV-2 stores message file activation's in a separate queue (see "queue" definition in glossary) for each output channel. Files can be added to the queue by a contact activation or a serial port start command. Files in each queue are played in the order of file priority. Equal priority files are played in the order of activation.

When a contact activation is detected, the programmed message file is placed on the programmed queue. The contact input is then not checked for activation again until the message file completes playing. Therefore, a momentary contact closure will only play a message file once and a maintained contact closure will continuously repeat a message file as long as its input is held activated (unless it is interrupted by a higher priority file, played alternately with other equal priority files, acknowledged, or reset). (See "acknowledge" and "reset" definitions in Glossary.)

When a valid serial port start command is received, the programmed message file is placed on the programmed queue. Each time the file completes playing, the Series MDV-2 checks to see if a valid serial port stop command has been received. If one has been received, the message file is removed from the queue. As long as the file is on the queue, it will repeat continuously (unless it is interrupted by a higher priority file, played alternately with other equal priority files, acknowledged, or reset).


## System Pause


The ability to have a pause between messages is provided. Having a pause between all playing messages prevents messages from "running together" and then being misunderstood. The system pause may be any value from 1 to 999 seconds.

## Supervision

A trouble condition indicates that the supervision functions have detected a malfunction in the Series MDV-2. When a trouble condition is detected, the Series MDV-2 may not be able to receive and/or remember message requests from the control panel. The installer and/or user must make sure that any message requests to the Series MDV-2 during a trouble condition are reactivated if necessary when the Series MDV-2 returns to normal.

If a trouble condition is detected by any of the supervision functions, the Series MDV-2 Form C status relay (normally energized) will change state, the green system normal LED will turn off, and the amber trouble LED will turn on. (The status relay contact closure must be properly connected to and used by the control panel to indicate a system trouble.) The amber trouble LED will identify if: (1) The Series MDV-2 unit is inoperative (steady light) or (2) Troubleshooting is required (coded blinking light). If a trouble condition is indicated, follow the procedures in the "Troubleshooting and Servicing" section.

 **WARNING:** DO NOT LEAVE THE SERIES MDV-2 IN A TROUBLE CONDITION, AS IT MAY NOT PLAY WARNING MESSAGES WHICH COULD RESULT IN PROPERTY DAMAGE AND SERIOUS INJURY OR DEATH TO YOU AND/OR OTHERS. IF THE SERIES MDV-2 INDICATES A TROUBLE CONDITION: (1) PROVIDE UL REQUIRED ALTERNATIVE SIGNALING AND (2) HAVE QUALIFIED SERVICE PERSONS IMMEDIATELY REPLACE UNIT(S) THAT HAVE MALFUNCTIONED.

 **WARNING:** MESSAGES REQUESTED BEFORE AND DURING A TROUBLE CONDITION MAY NOT BE HEARD, WHICH COULD RESULT IN PROPERTY DAMAGE AND SERIOUS INJURY OR DEATH TO YOU AND/OR OTHERS. IF MESSAGES REQUESTED BEFORE AND DURING A TROUBLE CONDITION ARE STILL NECESSARY, THEY SHOULD BE REPEATED WHEN THE SERIES MDV-2 IS RETURNED TO NORMAL.

### Input Voltage Supervision

Input voltage is supervised, and if the input voltage drops below the operating minimum voltage, the Series MDV-2 will stop operating and indicate a trouble condition. The input voltage is also supervised for ground faults.

### Program Memory Supervision

The Series MDV-2's program memory is supervised using sumcheck error techniques to detect any changes in EPROM data storage. If an error is detected, the Series MDV-2 will stop operating and indicate a trouble condition.

### Message Memory Supervision

The Series MDV-2's message memory is supervised using sumcheck error techniques to detect any changes in EPROM data storage. If an error is detected, the Series MDV-2 will stop operating and indicate a trouble condition.

### Microprocessor Supervision

The Series MDV-2 has a watchdog circuit that supervises the processor and resets it (if necessary) or maintains a trouble condition if the processor cannot be restarted. The watchdog circuit constantly monitors the execution of the processor program, and if the processor program fails to function properly, will attempt to reset and restart the processor.

## Audio Supervision

The audio circuitry of each output channel is supervised up to the channel output relay. When a message is playing, a trouble condition is indicated if an audio signal is not detected for more than 3 seconds or a low impedance load (less than 600 Ohms) is connected to the output. An audio signal not detected or low impedance load detected trouble condition will clear automatically as soon as audio is detected or the low impedance load is no longer detected, respectively. When no messages are playing, the circuitry is continuously supervised for functionality. If a circuitry failed condition is detected, a trouble condition is indicated.



**CAUTION:** External audio wiring is NOT supervised by the Series MDV-2. Wheelock strongly recommends that the control panel be designed to supervise the audio wiring.

## Serial Port Supervision

The Series MDV-2 can receive instructions over a serial port when the optional GFD-CIM Ground Fault Detection/Computer Interface Module is installed. The protocol used on the serial port is described in Appendix A.

The serial port is supervised for communication errors and ground faults. A trouble condition will be indicated if a communication error is detected, the Series MDV-2 does not select a file, or the received command is not understood. The trouble condition will return to normal with the next valid command received. See Appendix A for additional serial port information.

The Series MDV-2 also provides a response for each command received through the serial port. If so programmed, the control panel can supervise the serial port by receiving and comparing the response of each transmitted command. The control panel can both verify the integrity of the physical connection of the serial communication line and the integrity of the commands received by the Series MDV-2.



**CAUTION:** External wiring to/from the serial port of the Series MDV-2 is NOT supervised by the Series MDV-2. Wheelock strongly recommends that the control panel be programmed to use the Series MDV-2's serial response capability (described in Appendix A) to verify the integrity of the serial communications link and to record any communication errors for corrective action.

## Ground Fault Supervision

The Series MDV-2 has the ability to supervise for ground fault conditions on field wiring that is not electrically isolated when the optional GFD-CIM Ground Fault Detection/Computer Interface Module is installed. The supervised wiring includes contact inputs and serial port wiring. All other wiring is electrically isolated. Ground fault supervision may be enabled and disabled by placing the "GROUND FAULT ENABLE/DISABLE" jumper (JP2) on the GFD-CIM in the desired position. (See Figure 7 for the location of the jumper JP2 on the Ground Fault Detection/Computer Interface Module.)


## Standby Battery Calculations


To calculate standby battery ampere-hour capacity needed to back-up the Series MDV-2 system power based on maximum input current and number of output channels utilized, refer to the "Technical Specifications" section of this manual.

# Installation

The lives of people depend upon your safe installation of the Series MDV-2. Please read, understand and follow the specific installation instructions set forth below to avoid damage to the Series MDV-2 and equipment connected to it. Installation should be conducted only by qualified persons in accordance with procedures in this manual.


 **WARNING:**     **SHUT OFF ALL POWER BEFORE STARTING THE INSTALLATION. ELECTRICAL SHOCK CAN CAUSE DEATH OR SERIOUS INJURY.**

 **CAUTION:**     The Series MDV-2 printed circuit boards are sensitive to static electricity and have delicate components mounted on them. Before handling either a board or any component on a board, discharge any static electricity from your body by touching a grounded object such as a metal screw which is connected to earth ground. Handle the board by its edges, and be careful not to twist or flex it. The Series MDV-2 is to be installed in a static free area and the user is to properly attach grounded wrist straps before touching any static sensitive areas. After handling Series MDV-2 printed circuit boards, the Series MDV-2 should be tested in accordance with the "System Checkout" section to verify that the printed circuit boards are undamaged and functioning properly.

 **CAUTION:**     The Authority Having Jurisdiction (AHJ) should be consulted by the installer prior to installation.

## Installation Guidelines

1. Prepare a drawing of the complete system wiring. (Keep a copy of the system wiring drawing with the Series MDV-2 Manual as a permanent record of the system wiring.) See the "Wiring Guidelines" and the "Field Wiring" sections to help develop this drawing.
2. Carefully unpack the Series MDV-2 and make sure each item described on the packing slip is present and undamaged.
3. Mount the Series MDV-2 in the desired location as described in the "Mounting" section.
4. Mount any additional wiring boxes or junction boxes needed to interconnect field wiring.
5. Connect conduit fittings or bushings as needed using knockouts provided on the top and bottom of the Series MDV-2 units (see Figure 3).
6. Install field wiring in conduit when necessary, following the National Electrical Code and local codes for the type of system being installed. Make all necessary connections at any additional wiring or junction boxes.

 **CAUTION:**     Provide proper strain relief for all wiring not in conduit.


7. Connect the Series MDV-2 to earth ground, following the National Electrical Code and local codes for the type of system being installed, as described in the "Grounding" section.
8. Check the integrity of all field wiring following the directions in the "Field Wiring Checkout" section. Confirm that the specified cable is installed and that there is continuity between required points (no open circuits), with no unwanted connections (shorts) to other conductors, chassis, or earth ground.
9. Connect the wiring to the appropriate terminals of the Series MDV-2 modules following the directions in the "Field Wiring" section and the system wiring drawing you created in Step 1.
10. Apply power and perform the operational tests described in the "System Checkout" section.

## Wiring Guidelines




Although the Series MDV-2 incorporates signal verification and noise filtering circuitry on its input, induced voltages or noise on the input wiring can cause improper operation. Therefore, use shielded twisted pair wire for all fire input wiring. The audio output lines (and the auxiliary music input lines) should also be wired with shielded twisted pair to minimize noise pick-up. For all other connections, twisted pair is recommended to reject common mode noise, but shielding is optional.

The shield of each cable should be connected only at one end. Each shield of each cable that connects to the Series MDV-2 is to connect to the grounding points provided near the right edge of the chassis (see Figure 3).

 **WARNING:** ALL SERIES MDV-2 DRY CONTACT INPUT WIRING AND AUDIO WIRING SHOULD BE ROUTED AWAY FROM ANY HIGH VOLTAGE OR HIGH CURRENT LINES (SUCH AS AC OR DC POWER LINE, AUDIO POWER LINES, AND MOTOR OR RELAY ACTUATION LINES) AND SHOULD BE INSTALLED IN SEPARATE CONDUIT FROM HIGH VOLTAGE OR HIGH CURRENT LINES. FAILURE TO DO SO MAY CAUSE ELECTRICAL SHOCK RESULTING IN PROPERTY DAMAGE AND SERIOUS INJURY OR DEATH TO YOU AND/OR OTHERS.


The National Electrical Code defines two types of circuits for protective signaling systems: power limited circuits and non-power limited circuits. All Series MDV-2 circuits have been designed as power limited circuits and in order to maintain power limited ratings, circuits connected to the power supply, auxiliary source input, and relay contact terminals must be power limited.

 **CAUTION:** The National Electric Code limits the maximum number of conductors that can be installed in conduit and wiring boxes depending on the size of the conduit, the volume of the boxes, and the gauge of the wire used. Make sure that wiring used for Series MDV-2 installation complies with the latest NEC requirements for power limited circuits.

See the "Field Wiring" section for recommended wire sizes and wire type to use for all Series MDV-2 input and output lines.

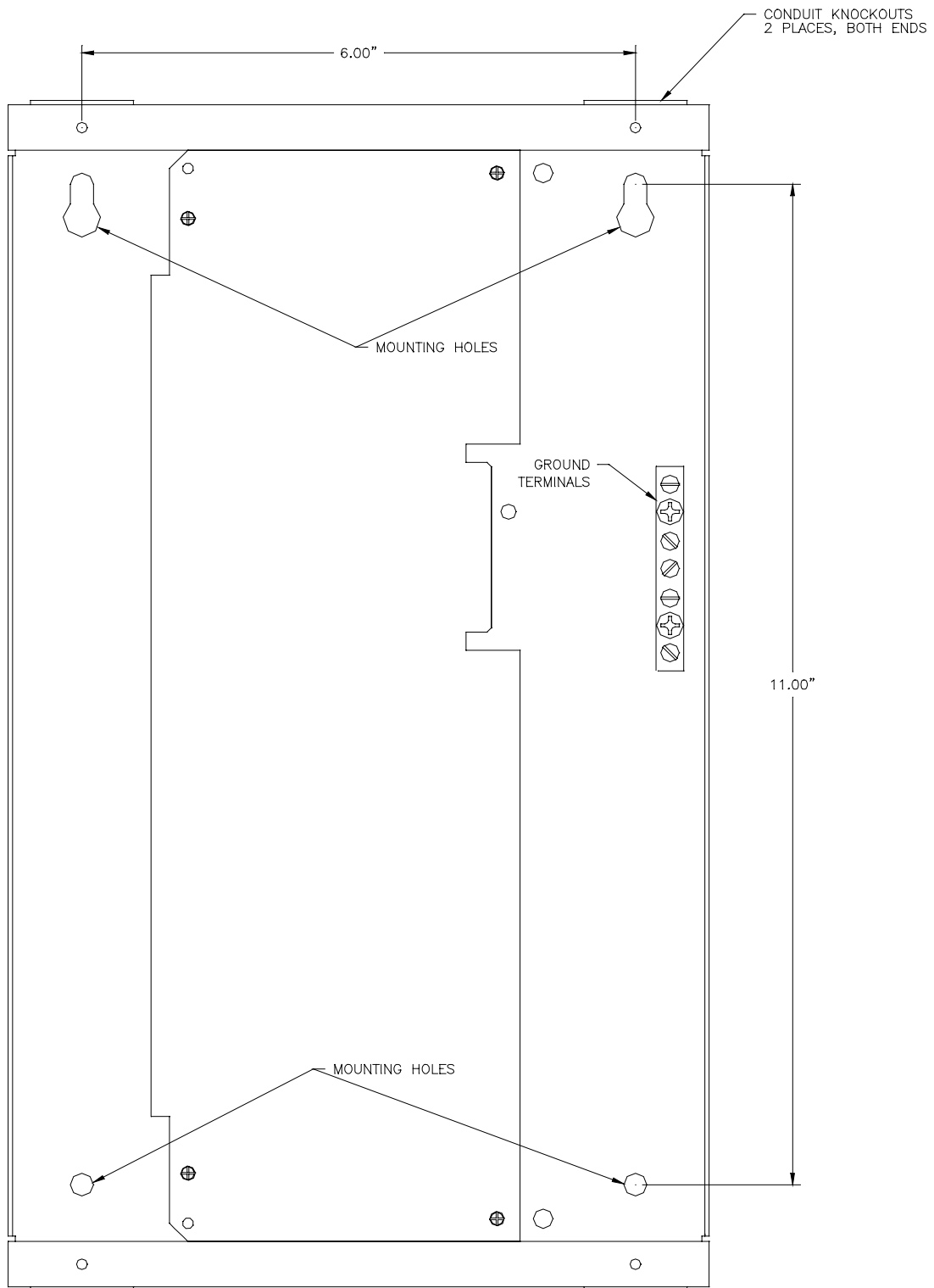
## Mounting

The Series MDV-2 shall be mounted in a location within the environmental limits specified in the latest UL Standard for indoor control panels. The Series MDV-2 shall not be located in a hazardous location. Refer to the "Technical Specifications" section.

 **CAUTION:** In order to comply with the latest NFPA and UL requirements for interconnection of fire alarm control equipment, the Series MDV-2 units must be located in the same room as, and within 20 feet of, a LISTED compatible fire alarm control panel and LISTED compatible audio system, or a LISTED compatible audio system, with the wiring enclosed in conduit and properly connected to such control panel and/or audio system.

Refer to Figure 3 for Series MDV-2 mounting hole layout. Drill mounting holes for appropriate screws and anchors to ensure secure mounting to the type of surface at the selected location. Keep out dust and dirt during installation. Dust and dirt can interfere with the operation and reduce the life of the equipment.

Remove the outer cover and mount the Series MDV-2 at the selected location. **Use care to avoid damage to the PC board during installation.** Do not apply excessive pressure to the PC board or its components, including field wiring terminals and connectors.



**Figure 3.**  
**Series MDV-2 Mounting**

## Grounding

The Series MDV-2 should be connected to earth ground in accordance with the National Electrical Code. Connecting the Series MDV-2 to earth ground will reduce the static discharge failures (which can include EPROM memory failure), improve transient protection, and reduce the chance of electrical shock. The Series MDV-2 should be grounded as follows:

- 1) Connect a wire between the ground screw on the printed circuit board and the ground terminals on the enclosure. See Figure 7 for location of the ground screw (labeled "EARTH GND") on the printed circuit board and Figure 3 for the location of the ground terminals on the enclosure.
- 2) Connect a wire between the ground terminals on the enclosure and earth ground.

## Field Wiring

Before installation, the system specifier must determine the proper wire gauge for all field wiring. The field wiring is broken down into six categories: file input, audio output, music input, channel playing contact, status contact, and input voltage.

Note: All field wiring shall conform to applicable codes and standards including NFPA, UL, local, state, county, province, district and federal codes and standards.

### Series MDV-2 Field Wiring Connection

All Series MDV-2 wiring terminals are designed to accept #22 AWG to #16 AWG wiring (one wire per terminal). Connect the field wiring to the Series MDV-2 terminals while referring to the following sections.

Check the integrity of all field wiring following directions in the "Field Wiring Checkout" section. Confirm that the specified cable is installed and there is continuity between required points (no "opened circuits"), with no unwanted connections ("shorts") to other conductors, chassis, or earth ground. **(Perform the field wiring checkout before continuing with any connections to the Series MDV-2 wiring terminals.)**



**WARNING: TO REDUCE THE RISK OF ELECTRICAL SHOCK, NEVER CONNECT OR DISCONNECT FIELD WIRING WHEN INPUT VOLTAGE IS CONNECTED TO THE SERIES MDV-2.**

#### Dry Contact Input Wiring

The dry contact inputs shall be dry contacts or open collector devices. Dry contacts or open collectors from multiple devices may be connected in parallel as shown in Hook-up A in Figure 4. If multiple inputs are located at the same location, the (-) input leg may be commoned to reduce wiring requirements as shown in Hook-up B in Figure 4.

Series MDV-2 dry contact inputs meet the requirements for power limited fire protective signaling circuits as defined in the National Electrical Code.

The gauge of the wire necessary for dry contact input wiring may vary for each dry contact input. The field wiring for each dry contact input shall not exceed 100 Ohms of resistance and 0.050 microfarads of capacitance.

#### Audio Output Wiring

One audio output is provided per zone. A detail of the audio output terminal connections is shown in Figure 5. Determination of wire gauge should consider all factors including loop length, audio output level, amplifier input sensitivity, audio output impedance, and amplifier input impedance.

#### Source Input Wiring

One source input is provided per zone. A detail of the source input terminal connections is shown in Figure 5. Determination of wire gauge should consider all factors including input loop length, output loop length, music source output level, amplifier input sensitivity, music source output impedance, and amplifier input impedance.

#### Channel Playing Contact Wiring

A normally open and normally closed channel play contact is provided per zone. They are rated for 0.5 Amps at 24VDC, resistive load. A detail of the channel play terminal connections is shown in Figure 5. Determination of wire gauge should consider all factors, including loop length, maximum current capacity and maximum voltage drop allowable.

#### Status Contact Wiring

One status contact is provided. It is Form C and is rated for 0.5 Amps at 24VDC, resistive load. A detail of the status contact terminal connections is shown in Figure 6. The contact in Figure 6 is shown in the trouble position. Determination of wire gauge for the status contact wiring should consider all factors, including loop length, maximum current capacity, and maximum voltage drop allowable.

Input Voltage Wiring

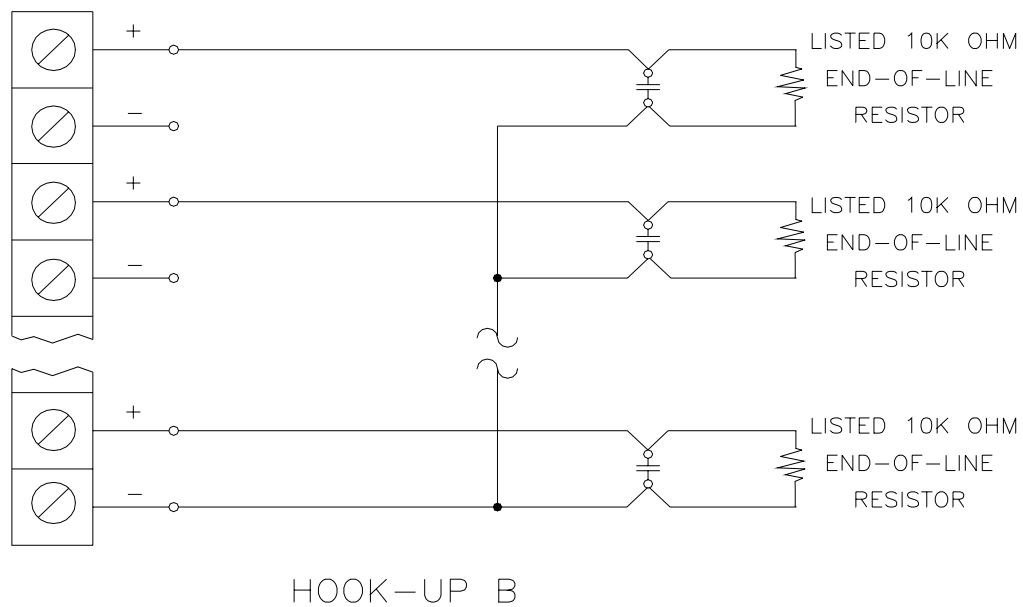
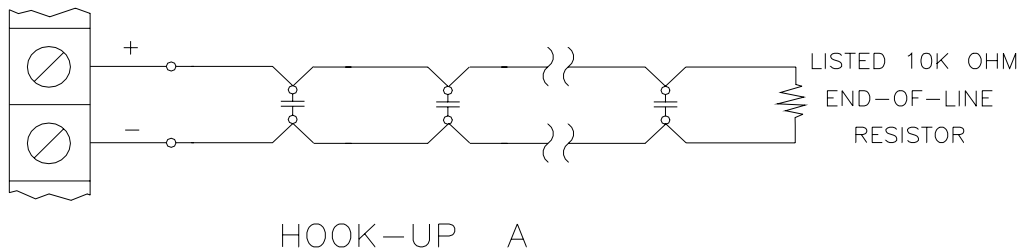
A detail of the input voltage terminal connections is shown in Figure 6. Determination of wire gauge for the input voltage wiring should consider all factors, including loop length, power supply voltage, maximum Series MDV-2 current consumption, and input voltage range of Series MDV-2.

**IT IS IMPORTANT THAT THE WIRING USED FOR INPUT VOLTAGE WIRING IS LARGE ENOUGH TO CARRY THE MAXIMUM CURRENT REQUIRED BY THE SERIES MDV-2 WITHOUT EXCESSIVE VOLTAGE DROP. IF VOLTAGE DROPS FROM POWER SUPPLY LOADING AND WIRING RESISTANCE ARE NOT WITHIN THE SPECIFIED OPERATING VOLTAGE RANGE, THE SERIES MDV-2 WILL NOT FUNCTION PROPERLY.**

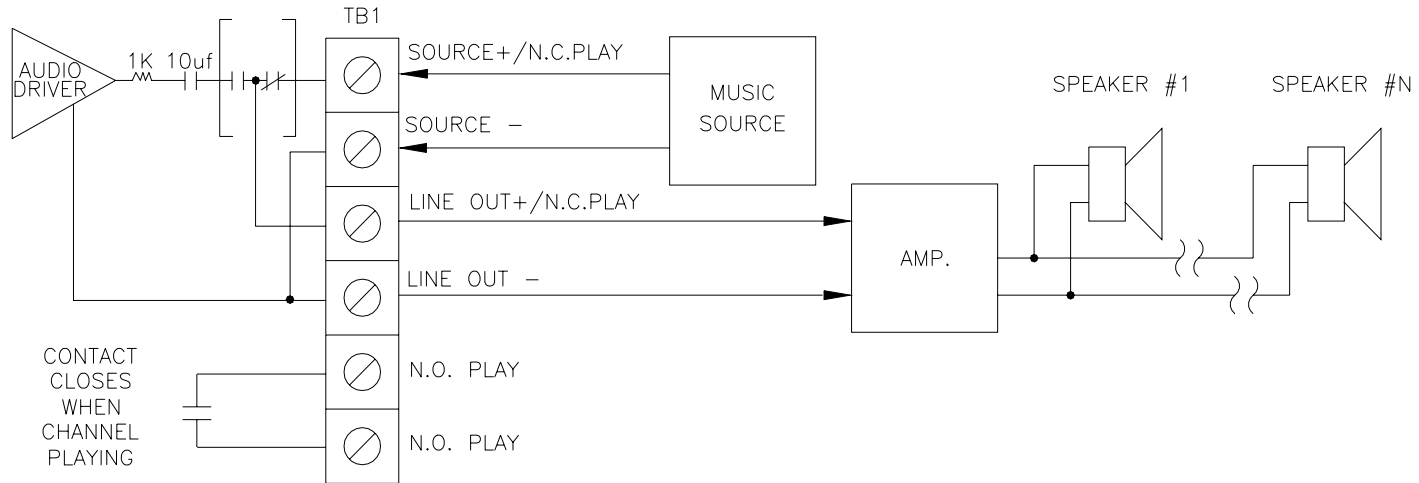
RS-232 Port Wiring

An optional RS-232 port is provided when using the Ground Fault Detection/Computer Interface Module. It is a three wire interface. The pin connections of the RS-232 port is shown in Figure 8. See Appendix A for protocol information.

Current RS-232 specifications limit RS-232 communication paths to 50 feet in length. A particular installation may be limited to shorter paths depending on factors such as wire gauge and wire capacitance.

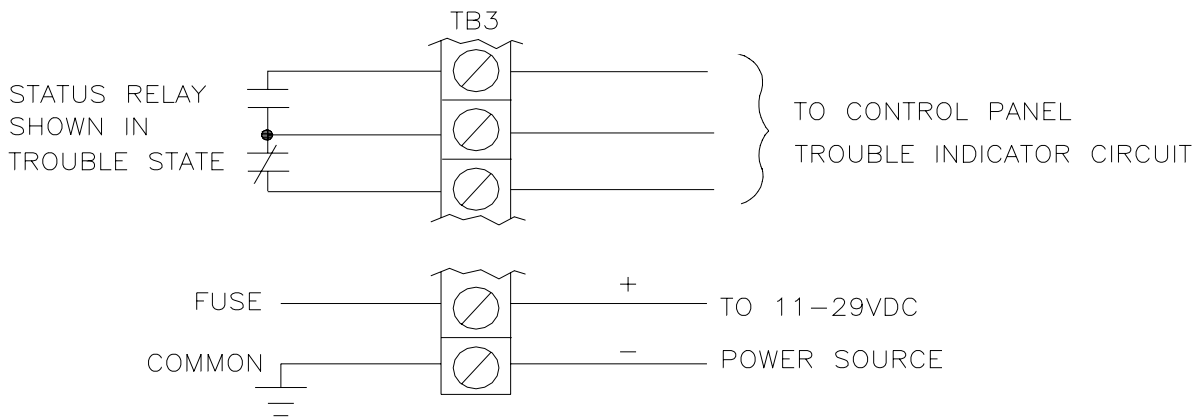


**Figure 4.**  
**Dry Contact Input Wiring**

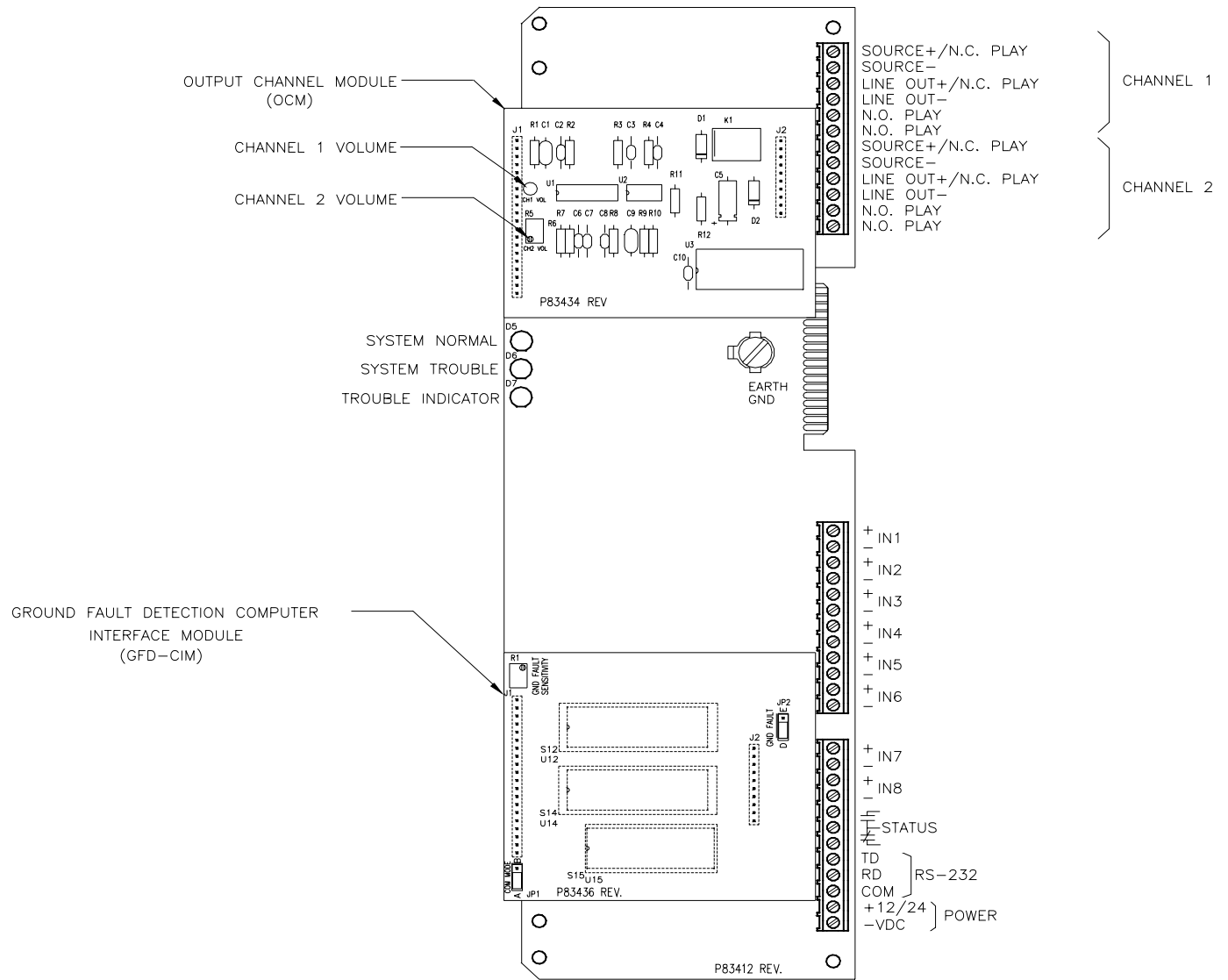


**⚠ WARNING:** THE AUDIO OUTPUT IS POLARITY SENSITIVE. FAILURE TO CONNECT THE WIRING WITH THE CORRECT POLARITY WILL PREVENT MESSAGES FROM PLAYING WHEN REQUIRED. THIS COULD RESULT IN PROPERTY DAMAGE AND SERIOUS INJURY OR DEATH TO YOU AND/OR OTHERS.

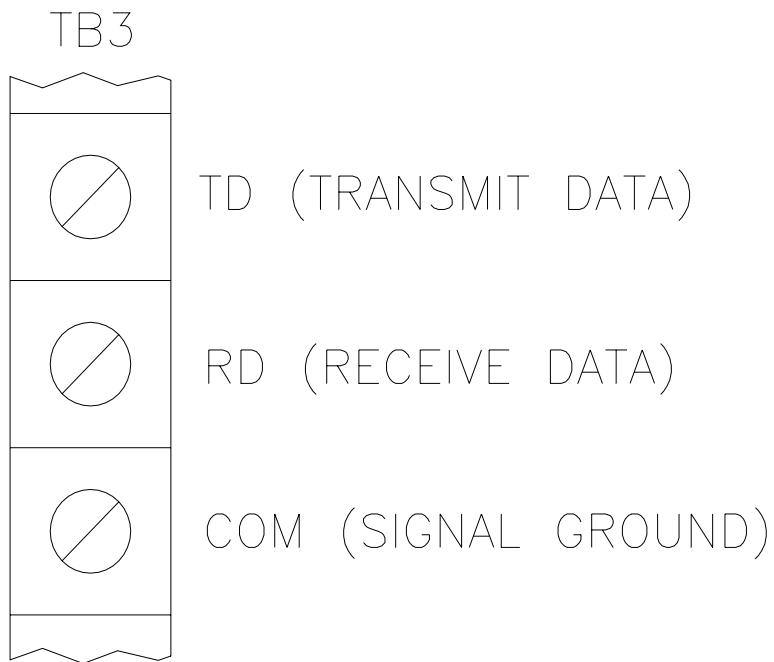
**Figure 5.**  
**Audio Output/Music Input/Channel Playing Wiring**



**Figure 6.**  
**Input Voltage And Status Contact Wiring**



**Figure 7.**  
**Series MDV-2 Board Layout**



**Figure 8.**  
**RS-232 Port Pin Connection**

## Field Wiring Checkout

Refer to NFPA for guidelines on testing signaling system wiring.

**CAUTION:** Do not connect input voltage to any equipment until the field wiring has been inspected and approved.

Verify that the field wiring is in full agreement with this manual and with the detailed wiring layout prepared for this installation.

Ensure that no unwanted voltages are present on circuit conductors and ground. Test all ungrounded connectors for electrical isolation from ground. Test all wires that are not intentionally connected for electrical isolation from each other. Measure and record the resistance of each circuit pair (this can be done by temporarily short circuiting one end of the circuit).

# System Checkout

Refer to NFPA for guidelines on testing signaling systems.

When rated input voltage is applied to the Series MDV-2, the unit initializes its program and broadcasts a tone signal through each output channel for several seconds. The green system normal LED indicator should be on to indicate normal operation. If the amber system trouble LED is on, a trouble condition is indicated. Refer to the "Troubleshooting and Servicing" section to diagnose and correct the trouble condition.

The system checkout should include:

1. Testing all inputs and outputs.
2. Testing all connections to equipment that is interconnected with the Series MDV-2.
3. Testing all message files for proper audibility, intelligibility, content and priority.

If a malfunction is discovered during testing, the problem should be corrected immediately before continuing with testing.



**WARNING: ALL PROTECTIVE SIGNALING SYSTEMS REQUIRE PERIODIC TESTING. ALL PROTECTIVE SIGNALING SYSTEM EQUIPMENT SHALL BE TESTED BY QUALIFIED PERSONNEL AT LEAST TWICE A YEAR FOR PROPER OPERATION, OR MORE OFTEN IF REQUIRED BY CODES, REGULATIONS AND LAWS. FAILURE TO MAINTAIN AND TEST PROTECTIVE SIGNALING SYSTEM EQUIPMENT CAN RESULT IN NOT DETECTING EQUIPMENT FAILURE THAT CAN CAUSE PROPERTY DAMAGE AND SERIOUS PERSONAL INJURY OR DEATH TO YOU AND/OR OTHERS DURING AN EMERGENCY SITUATION.**

## Ground Fault Detection Sensitivity Adjustment

The resistance at which a ground fault will be detectable is adjustable. The Series MDV-2 ground fault detection sensitivity can be adjusted between 40K and 500K Ohms. Selecting a high sensitivity (high resistance) will have a fast response to ground fault conditions, but may also cause a high number of false trouble conditions. Selecting a low sensitivity (low resistance) will greatly reduce the susceptibility to false trouble conditions, but will slow the response to ground fault conditions.

Before the following adjustment procedure is performed, all trouble conditions must be corrected (cleared) and the "GROUND FAULT ENABLE ("E")/DISABLE ("D") jumper located on the Ground Fault Detection/Computer Interface Module, must be placed in the enable position.

**NOTE:** The ground fault detection sensitivity setpoint must be approved by the authorities having jurisdiction.

### Adjustment Procedure

1. Disconnect the wire between the earth ground terminal on the printed circuit board (see Figure 7) and earth ground.
2. Rotate the shaft of the Ground Fault Detection Sensitivity potentiometer fully counter clockwise (See Figure 7). The potentiometer is a twelve turn device, so the shaft will probably have to be rotated a number of times. The potentiometer will make a clicking sound as it is rotated past its end point.
3. Place a resistor with the desired setpoint value between the positive side of the input voltage and the earth ground terminal on the printed circuit board.
4. Slowly rotate the shaft of the Ground Fault Detection Sensitivity potentiometer clockwise. When a ground fault is indicated by the trouble LED's, the sensitivity setpoint is set correctly.
5. Disconnect the resistor used to set the sensitivity level.
6. Reconnect the wire between the earth ground terminal on the printed circuit board and earth ground.



# Troubleshooting

**⚠ WARNING:** SOME ELECTRONIC COMPONENTS STORE A HIGH VOLTAGE CHARGE, EVEN THOUGH POWER IS NOT CONNECTED, AND CAN CAUSE A DANGEROUS SHOCK IF TOUCHED. DO NOT TOUCH EXPOSED CIRCUITRY ON THE SERIES MDV-2 UNLESS THE CIRCUITRY HAS DISCHARGED FOR ONE HOUR AND A SAFE DISCHARGE PROCEDURE IS USED.

**⚠ WARNING:** PROVIDE ALTERNATIVE SIGNALING MEANS DURING TROUBLE CONDITIONS AND SERVICING TO ASSURE ADEQUATE PROTECTION OF PEOPLE AND PROPERTY. HAVE QUALIFIED SERVICE PERSONS IMMEDIATELY REPLACE ANY UNIT(S) THAT HAVE MALFUNCTIONED.

**⚠ CAUTION:** Troubleshooting and servicing should be conducted only by qualified persons in accordance with the procedures in this manual. Do not attempt to make other adjustments, modifications, or repairs. Never use water, steam, cleaning liquids or sprays on the Series MDV-2.

**⚠ CAUTION:** User servicing of the Series MDV-2 is limited to the following:

- Field wiring changes following the instructions in the "Installation" section.
- Procedures set forth in this section.

**⚠ CAUTION:** Do not paint or in any way cover LED's.

## AFTER ANY TROUBLESHOOTING PROCEDURE IS COMPLETED, PERFORM A COMPLETE SYSTEM CHECKOUT.

When a trouble condition is detected by the Series MDV-2 the Form C status relay (normally energized) will change state, the green system normal LED will turn off and the amber system trouble LED will turn on. At the same time, the amber trouble indicator LED will indicate a Series MDV-2 inoperative condition (steady on) or troubleshooting required condition (coded blinking).

Use Table 1 to determine the trouble condition and the correct troubleshooting procedure to follow.

System Normal LED (Green)	System Trouble LED (Amber)	Trouble Indicator LED (Amber)	What it Means	Troubleshooting Procedure
On	Off	Off	Normal	----
Off	Off	Off	Power Loss	A
Off	On	Off	Series MDV-2 Inoperative	B
Off	On	Steady-On	Series MDV-2 Inoperative	C
Off	On	2 Blink Pattern	Message Memory EPROM Error	D
Off	On	4 Blink Pattern	Output Channel Error	F
Off	On	5 Blink Pattern	Serial Port Communication Error	G
Off	On	6 Blink Pattern	Ground Fault Detected	H

**Table 1.**

## Replacement Procedure

After all troubleshooting operations have been performed, return any units that are malfunctioning for factory repair or replacement. If it is necessary to return a Series MDV-2, replace the malfunctioning unit(s) immediately in the following manner:

1. Make sure that alternative signaling means are in place and that the proper replacement units are available.
2. Disconnect power from the power source to the Series MDV-2.
3. Identify all wiring connections to make sure they will be reconnected identically on the replacement.
4. Disconnect all wiring connections and any conduit or cable connections to the malfunctioning unit.
5. Remove the malfunctioning unit(s) and install the replacement unit(s) following the instructions in the "Installation" section of this manual. Perform all checkout procedures described in that section to make sure the replacement unit(s) are operating properly.

## Procedure A

If the green system normal LED, the amber system trouble LED, and the amber trouble indicator LED are off, the Series MDV-2 may be completely inoperative due to power loss. This condition is caused by:

1. Input voltage is not within proper range or polarity is incorrect.
2. Blown fuse (F1) on Series MDV-2.
3. One or more LED's are broken.

Perform the following:

1. Verify that input voltage is within proper range and that polarity is correct.
2. Check fuse (F1) on Series MDV-2.

If, after the above procedure is completed, the trouble condition persists, the trouble condition is caused by broken LED's on the Series MDV-2. These LED's are not field replaceable. Series MDV-2's with broken LED's shall be replaced immediately, following the Replacement Procedure, set forth previously in this section.

## Procedure B

If the green system normal LED is off, the amber system trouble LED is on, and the amber trouble indicator LED is off, the Series MDV-2 may be completely inoperative. This condition is caused by:

1. Too low input voltage on the Series MDV-2.
2. Missing or improperly inserted program memory EPROM.
3. Broken amber trouble indicator LED (Series MDV-2 is operative if this is the cause).
4. Failed circuitry on the Series MDV-2.

Perform the following:

1. Verify that the input voltage exceeds the minimum operating voltage.
2. Verify that the program memory EPROM is present and inserted into socket S15 properly (see Figure 7 for S15 location).
3. Attempt to play a message file. If the file plays then the amber trouble indicator LED is broken.

If, after the above procedure is completed, the trouble condition persists, the trouble condition is caused by failed circuitry on the Series MDV-2. There are no field correctable failed circuitry problems on the Series MDV-2. Series MDV-2's with failed circuitry shall be replaced immediately, following the Replacement Procedure, set forth previously in this section.

## Procedure C

If the green system normal LED is off, the amber system trouble LED is on, and the amber trouble indicator LED is steady on, the Series MDV-2 is partially or completely inoperative. The Series MDV-2 can be rendered inoperative by:

1. Too low input voltage on the Series MDV-2.
2. Failed audio channel on the Series MDV-2 or the Output Channel Module.
3. Other failed circuitry on the Series MDV-2, the Output Channel Module, or the Ground Fault Detection/Computer Interface Module.
4. An improperly installed Output Channel Module or Ground Fault Detection/Computer Interface Module.

If the error was due to the first cause, the Series MDV-2 will not play messages. If the error was due to the second cause, the Series MDV-2 might play messages and the serial port will function properly. If the error was due to the third or fourth cause, the Series MDV-2 may play messages and the serial port may function depending on the nature of the problem.

When the Series MDV-2 is rendered inoperative, perform the following:

1. Verify that the input voltage exceeds the minimum operating voltage.
2. Verify that if used, the Output Channel Module and Ground Fault Detection/Computer Interface Module are properly installed.
3. Remove the Ground Fault Detection/Computer Interface Module if it is installed. If the trouble condition clears the Ground Fault Detection/Computer Module is defective.
4. If the Output Channel Module is being used, replace it with a known properly functioning unit. If the trouble condition clears, the Output Channel Module is defective.
5. Attempt to play messages on all installed audio channels.

If, after the above procedure is completed, the trouble condition persists, the trouble condition is caused by failed circuitry on the Series MDV-2. There are no field correctable failed circuitry problems on the Series MDV-2, Output Channel Module or Ground Fault Detection/Computer Interface Module and these components if defective shall be replaced immediately, following the Replacement Procedure, set forth previously in this section.

## Procedure D

If the green system normal LED is off, the amber system trouble LED is on, and the amber trouble indicator LED flashes a 2-blink pattern, a message memory EPROM error has occurred. A message memory EPROM error may be caused by:

1. Pre-programmed message memory EPROM's not installed into Series MDV-2 in proper order.
2. No messages programmed into message memory EPROM's.
3. Missing or improperly installed message memory EPROM's.
4. One or more of the messages were not programmed completely.
5. Failed circuitry on the Series MDV-2.
6. The optional Output Channel Module is installed when not required.

If the error was due to one of the first four causes, the trouble will clear automatically when the cause is corrected. The first four causes should only occur when power is first turned on to the Series MDV-2.

When a message memory error is indicated, perform the following:

1. Verify that the preprogrammed message memory EPROM's were installed in the correct sockets on the Series MDV-2. An EPROM must always be installed in socket S14. If between one and two minutes of message memory is required, the first EPROM must be installed into socket S14 and the second EPROM into socket S12.
2. Verify that there is at least one message programmed into the message memory EPROM's.
3. Verify that all message memory EPROM's are inserted into their sockets properly.
4. Verify that there are no partially programmed messages on the message memory EPROM's. This can only be done using commands on the serial port which is located on the optional Ground Fault Detection/Computer Interface Module.
5. Remove the optional Output Channel Module if your message files require only channel one.

If, after the above procedure is completed, the trouble condition persists, the trouble condition is caused by failed circuitry on the Series MDV-2. There are no field correctable failed circuitry problems on the Series MDV-2. Series MDV-2's with failed circuitry shall be replaced immediately, following the Replacement Procedure, set forth previously in this section.

## Procedure E (Not Used)

## Procedure F

If the green system normal LED is off, the amber system trouble LED is on, and the amber trouble indicator LED flashes a 4-blink pattern, an audio channel error has occurred. An audio channel error may be caused by:

1. Too low an audio level while playing a message.
2. Pause in message while playing a message that lasts longer than 3 seconds.
3. The audio output is loaded down by a low impedance input device.
4. The optional Output Channel Module for channel two is not installed or is improperly installed. The number of output channels installed must agree with the number of output channels used in the Programmed Message Kit.
5. Failed audio channel on Series MDV-2 or an optional Output Channel Module.

If the error occurs while playing a file, the error was due to one of the first three possible causes. If the error occurs immediately after turning on power to the Series MDV-2, the error was due to one of the last two possible causes.

If the error was due to the first or second cause while playing a message, the trouble will clear automatically when audio is again detected while a message is playing. If the error was due to the third cause, the trouble will clear automatically when the output is no longer loaded down while a message is playing. If the error was due to the fourth cause, the trouble will clear automatically when the module is properly installed and input power is cycled off and on.

When an audio channel error is indicated, perform the following:

1. Turn up volume on Series MDV-2 and/or the optional Output Channel Module (if installed).
2. Have the message re-recorded, shortening duration of the pause.
3. Check impedance of line output wiring and impedance of input device.
4. Verify that the optional Output Channel Module is installed properly.
5. Replace the Output Channel Module with a known properly functioning unit. If the trouble condition clears, the Output Channel Module is defective.

If, after the above procedure is completed, the trouble condition persists, the trouble condition is caused by failed circuitry on the Series MDV-2. There are no field correctable failed circuitry problems on the Series MDV-2 or Output Channel Module and these components if defective shall be replaced immediately following the Replacement Procedure set forth previously in this section.

## Procedure G

If the green system normal LED is off, the amber system trouble LED is on, and the amber trouble indicator LED flashes a 5-blink pattern, a serial port communication error that is located on the optional Ground Fault Detection/Computer Interface Module has occurred. A serial port communication error may be caused by:

1. Invalid command received.
2. Incorrect baud rate.
3. Incorrect data format.
4. Parity error.
5. Framing error.
6. Improperly installed or malfunctioning optional Ground Fault Detection/Computer Interface Module.

If the error was due to the first cause, the trouble will clear automatically on the next valid command received. If the error was due to the second or third cause, the trouble will clear automatically after the first valid data byte is received with the correct baud rate and data format. If the error was due to the fourth or fifth cause, the trouble will clear automatically after the next valid data byte is received. If the error was due to the sixth cause, the trouble will clear after the Ground Fault Detection/Computer Interface Module is properly installed or replaced and input power is cycled off and on.

When a serial communication error is indicated, perform the following:

1. Verify that the Series MDV-2 is connected to a system which supports the Wheelock serial port protocol and provides the correct data format.
2. Verify that the Ground Fault Detection/Computer Interface Module is installed properly.
3. Transmit a valid command to the Series MDV-2 through the serial port.
4. Replace the Ground Fault Detection/Computer Interface Module with a known properly functioning unit and transmit a valid command to the Series MDV-2. If the trouble condition clears, the Ground Fault Detection/Computer Interface Module is defective.

If, after the above procedure is completed, the trouble condition persists, the trouble condition is caused by failed circuitry on the Series MDV-2. There are no field correctable failed circuitry problems on the Series MDV-2 or Ground Fault Detection/Computer Interface Module and these components if defective shall be replaced immediately, following the Replacement Procedure, set forth previously in this section.

## Procedure H

If the green system normal LED is off, the amber system trouble LED is on, and the amber trouble indicator LED flashes a 6-blink pattern, a ground fault that is located on the optional Ground Fault Detection/Computer Interface Module has been detected. A ground fault detected error may be caused by:

1. Contact input wiring shorted to earth ground.
2. RS-232 wiring shorted to earth ground.
3. Input power wiring shorted to earth ground.
4. Line out wiring shorted to earth ground.
5. Ground fault detection sensitivity is set too high.
6. Improperly installed Ground Fault Detection/Computer Interface Module.
7. Failed ground fault detection circuitry on the Ground Fault Detection/Computer Interface Module.

If the error was due to one of the first five causes, the trouble will clear automatically when the cause is corrected. If the error was due to the sixth or seventh cause, the trouble will clear after the Ground Fault Detection/Computer Interface Module is properly installed or replaced and input power is cycled off and on.

When a ground fault detected error is indicated, perform the following:

1. Check all contact input wiring for ground faults.
2. Check all RS-232 wiring for ground faults.
3. Check all input power wiring for ground faults.
4. Check all line out wiring for ground faults.
5. Decrease the ground fault detection sensitivity level, following the adjustment procedure set forth in the Ground Fault Detection Sensitivity Adjustment section of this manual.
6. Verify that the Ground Fault Detection/Computer Interface Module is installed properly.
7. Replace the Ground Fault Detection/Computer Interface Module with a known properly functioning unit. If the trouble condition clears, the Ground Fault Detection/Computer Interface Module is defective.

If, after the above procedure is completed, the trouble condition persists, the trouble condition is caused by failed circuitry on the Series MDV-2. There are no field correctable failed circuitry problems on the Series MDV-2 or Ground Fault Detection/Computer Interface Module and these components if defective shall be replaced immediately, following the Replacement Procedure, set forth previously in this section.

# Periodic Testing

PERIODIC SYSTEM TESTING, INCLUDING THE SERIES MDV-2, ALL NOTIFICATION EQUIPMENT AND ALL MESSAGES INCLUDING THEIR CONTENT AND LANGUAGE, SEQUENCE, OUTPUT CHANNEL, AND PRIORITY ASSIGNMENT, MUST BE CONDUCTED FREQUENTLY, AT LEAST TWICE EACH YEAR, OR MORE OFTEN AS REQUIRED BY LOCAL, STATE AND FEDERAL CODES, REGULATIONS AND LAWS, BY QUALIFIED PERSONNEL TO ENSURE PROPER OPERATION OF ALL EQUIPMENT. If the notification equipment is not working properly, immediately contact the installer and have all/any problems corrected immediately. Malfunctioning units should be replaced immediately. Do not attempt to repair malfunctioning units. Malfunctioning units should be returned for factory repair or replacement. In the event you cannot contact the installer, contact the manufacturer.

To aid qualified personnel in performing necessary operational testing procedures, a script, listing all messages programmed in the digital voice module, must be kept with the digital voice module.



**WARNING: PROVIDE ALTERNATIVE SIGNALING MEANS DURING PERIODIC TESTING TO ASSURE ADEQUATE PROTECTION OF PEOPLE AND PROPERTY. FAILURE TO PROVIDE ALTERNATIVE SIGNALING MAY CAUSE PEOPLE TO NOT BE WARNED OF AN EMERGENCY CONDITION WHICH COULD RESULT IN PROPERTY DAMAGE AND SERIOUS INJURY OR DEATH TO YOU AND/OR OTHERS.**

In addition to testing required by relevant fire codes, regulations and laws, several hardware functions should also be tested. The hardware functions that should be tested are as follows:

1. The "short circuit" detection circuitry for any one or all of the eight contact inputs.
2. The serial port receiver.
3. The play contacts for each of the two output channels.
4. The audio supervision circuitry for each of the audio channels.
5. The status contact.

These hardware functions may be tested, respectively, as follows:

1. Activate (short circuit) each contact input and verify that proper message plays.
2. Transmit a serial port command to the digital voice module and check for a valid acknowledge response.
3. Monitor the play contacts for each channel to verify proper operation while alternately playing and not playing files on the output channel.
4. Listen to each message and check for audibility of each message.
5. Monitor the status contact while causing the digital voice module to alternate between trouble and normal states to verify proper operation.

If the digital voice module fails to perform any of the above tests correctly, immediately replace it following the replacement procedure given in the "Troubleshooting" section.

# Technical Specifications

## Mechanical

Dimensions (H x W x D)	13.0" x 7.6" x 2.15"
Weight	3.8 pounds
Enclosure	0.050" Steel
Finish	Black
Mounting	Indoor Surface Mount Top and Bottom Wiring Entry

## Environmental

(Meets UL requirements)	
Operating Temperature	0° to +49° C
Storage Temperature	-20° to 70° C
Humidity	85±5% @ 30±2° C Non-condensing

## Playback

Memory Type	EPROM
Memory Time	1 to 2 Minutes
Bandwidth	70 Hz to 4000 Hz
Maximum Files	999
Signal to Noise Ratio	51 dB
THD 1 KHz (full scale)	5.5 %

## Power Limited Wiring

All Series MDV-2 circuits are power limited. Therefore, to maintain power limited ratings, circuits connected to power supply, auxiliary source input, and relay contact terminals must be power limited.

# Electrical

## Input Voltage

Operating: 11 - 29VDC  
Ripple: 500 mV

## Maximum Input Current

	Voltage	11VDC	24VDC	29VDC
One Channel	Standby	85 mA	70 mA	75 mA
	Alarm	110 mA	80 mA	85 mA
Two Channel	Standby	100 mA	80 mA	85 mA
	Alarm	120 mA	90 mA	90 mA

## Inrush Current

Voltage	11VDC	24VDC	29VDC
Current	5A	10A	13A

The inrush current draw settles to a steady-state current draw within 3 milliseconds.

## Fuse

F1 (Power Input) 500 mA (1/2 Amp)  
(5 x 20 mm "Slo-Blo" Type Littlefuse Cat. No. 239.500)

## Inputs

### Message File Activation

File Input Terminals Input terminals for 8 message files on each MDV-2. Activate files for 300 millisecond minimum with a short across input (to sink up to 10 mA current with maximum 1VDC drop)

Digital Command Through serial port, RS-232.


Source Input Provided for each output channel. Requires 0.5 to 2.0 Vrms music source. Switched out when file is played.

## Outputs

Audio Output 1 or 2 output channels optionally provided; single ended capacitively coupled output. Output level adjustable from 0.5 to 2.0 Vrms. Minimum Load Impedance 600 Ohms.

Status Contact Form C contacts normally energized. Contacts transfer during trouble. Rated 0.5 Amps at 30VDC max, resistive load.

Channel Playing Contact One set for each channel. Normally open contacts closed when the channel is playing, normally closed contacts open when the channel is playing. The contacts are rated at 0.5 Amps at 30VDC max, resistive load.

 **WARNING:** DO NOT EXCEED THE RATINGS OF THE CONTACTS. EXCEEDING THE RATINGS MAY CAUSE THE RELAY TO FAIL. IF THE RELAY FAILS, THE SERIES MDV-2 MAY NOT BE ABLE TO PROVIDE THE INTENDED WARNING WHICH COULD RESULT IN PROPERTY DAMAGE AND SERIOUS INJURY OR DEATH TO YOU AND/OR OTHERS.

## Wiring Connections

Screw Terminals Each terminal accepts one conductor from #22 to #16 AWG.

---

# Glossary

## A

**acknowledge.** A serial port command or a dry contact input which will cause a message file of priority level 4 or 5 that is continuously activated to stop repeating after having played at least once.

**activation.** An input that causes a file to be selected and processed.

## C

**card.** An optional printed circuit board that can be installed onto a main printed circuit board.

**channel.** An audio output path through which the Series MDV-2 transmits message files to the audio system. Each Series MDV-2 can have up to two channels.

## E

**EPROM.** Erasable Programmable Read Only Memory. Non-volatile semiconductor memory used to store MDV-2 message files and programming. For reprogramming, this memory can be erased with special ultraviolet equipment.

## F

**file.** Series MDV-2 files are created either by storing audio directly into a selected file number or by storing the numbers of other files that contain audio into the selected file number. Every file is assigned an output channel and a priority level. Up to 999 files can be accessed in the Series MDV-2. A file becomes a message file if it is selected to be played by a contact closure or by a command through the serial port. Some files are never intended to become message files; they merely contain words or phrases that can be strung together to create new files that will become message files. The new files will be assigned channel and priority designations that supersede previous channel and priority designations for the individual files in the new string.

## M

**MDV-2.** Modular Digital VoiceLink playback series described in this manual.

**message.** An audio output generated and played through an assigned channel when a file number is selected by a contact closure or command on the serial port.

## P

**priority.** The order by which files are designated to be played. All files are assigned a priority from 1 to 5, with 1 as the highest priority.

## Q

**queue.** A sequence of message files that have been selected to be played through a particular channel. Each file is positioned according to its pre-assigned priority. Equal priority files are positioned in the order they were selected. A file cannot be included in this queue more than once. However, after a file has completed playing, it can be re-added to the queue.

## R

**reset.** A serial port command or a dry contact input which will cause the file presently playing to stop immediately and remove all files from the queue.

## S

**string.** A combination of file numbers (with optional delay or repeat commands) stored in a file and arranged to form a desired message.



## **Limited Warranty**

Wheelock products must be used within their published specifications and must be PROPERLY specified, applied, installed, operated, maintained and operationally tested in accordance with these instructions at the time of installation and at least twice a year or more often and in accordance with local, state and federal codes, regulations and laws. Specification, application, installation, operation, maintenance and testing must be performed by qualified personnel for proper operation in accordance with all of the latest National Fire Protection Association (NFPA), Underwriters' Laboratories (UL), Underwriters' Laboratories of Canada (ULC), National Electrical Code (NEC), Occupational Safety and Health Administration (OSHA), local, state, county, province, district, federal and other applicable building and fire standards, guidelines, regulations, laws and codes including, but not limited to, all appendices and amendments and the requirements of the local authority having jurisdiction (AHJ). Wheelock products when properly specified, applied, installed, operated, maintained and operationally tested as provided above are warranted against mechanical and electrical defects for a period of three years from date of manufacture (as determined by date code). Correction of defects by repair or replacement shall be at Wheelock's sole discretion and shall constitute fulfillment of all obligations under this warranty. THE FOREGOING LIMITED WARRANTY SHALL IMMEDIATELY TERMINATE IN THE EVENT ANY PART NOT FURNISHED BY WHEELOCK IS INSTALLED IN THE PRODUCT. THE FOREGOING LIMITED WARRANTY SPECIFICALLY EXCLUDES ANY SOFTWARE REQUIRED FOR THE OPERATION OF OR INCLUDED IN A PRODUCT. WHEELOCK MAKES NO REPRESENTATION OR WARRANTY OF ANY OTHER KIND, EXPRESS, IMPLIED OR STATUTORY WHETHER AS TO MERCHANTABILITY, FITNESS FOR A PARTICULAR PURPOSE OR ANY OTHER MATTER.

USERS ARE SOLELY RESPONSIBLE FOR DETERMINING WHETHER A PRODUCT IS SUITABLE FOR THE USER'S PURPOSES, OR WHETHER IT WILL ACHIEVE THE USER'S INTENDED RESULTS. THERE IS NO WARRANTY AGAINST DAMAGE RESULTING FROM MISAPPLICATION, IMPROPER SPECIFICATION, ABUSE, ACCIDENT OR OTHER OPERATING CONDITIONS BEYOND WHEELOCK'S CONTROL.

SOME WHEELOCK PRODUCTS CONTAIN SOFTWARE. WITH RESPECT TO THOSE PRODUCTS, WHEELOCK DOES NOT WARRANT THAT THE OPERATION OF THE SOFTWARE WILL BE UNINTERRUPTED OR ERROR-FREE OR THAT THE SOFTWARE WILL MEET ANY OTHER STANDARD OF PERFORMANCE, OR THAT THE FUNCTIONS OR PERFORMANCE OF THE SOFTWARE WILL MEET THE USER'S REQUIREMENTS. WHEELOCK SHALL NOT BE LIABLE FOR ANY DELAYS, BREAKDOWNS, INTERRUPTIONS, LOSS, DESTRUCTION, ALTERATION, OR OTHER PROBLEMS IN THE USE OF A PRODUCT ARISING OUT OF OR CAUSED BY THE SOFTWARE.

THE LIABILITY OF WHEELOCK ARISING OUT OF THE SUPPLYING OF A PRODUCT, OR ITS USE, WHETHER ON WARRANTIES, NEGLIGENCE, OR OTHERWISE, SHALL NOT IN ANY CASE EXCEED THE COST OF CORRECTING DEFECTS AS STATED IN THE LIMITED WARRANTY AND UPON EXPIRATION OF THE WARRANTY PERIOD ALL SUCH LIABILITY SHALL TERMINATE. WHEELOCK IS NOT LIABLE FOR LABOR COSTS INCURRED IN REMOVAL, REINSTALLATION OR REPAIR OF THE PRODUCT BY ANYONE OTHER THAN WHEELOCK OR FOR DAMAGE OF ANY TYPE WHATSOEVER, INCLUDING BUT NOT LIMITED TO, LOSS OF PROFIT OR INCIDENTAL OR CONSEQUENTIAL DAMAGES. THE FOREGOING SHALL CONSTITUTE THE SOLE REMEDY OF THE PURCHASER AND THE EXCLUSIVE LIABILITY OF WHEELOCK.

IN NO CASE WILL WHEELOCK'S LIABILITY EXCEED THE PURCHASE PRICE PAID FOR A PRODUCT.

## **Limitation of Liability**

WHEELOCK'S LIABILITY ON ANY CLAIM OF ANY KIND, INCLUDING NEGLIGENCE AND BREACH OF WARRANTY, FOR ANY LOSS OR DAMAGE RESULTING FROM, ARISING OUT OF, OR CONNECTED WITH THIS CONTRACT, OR FROM THE MANUFACTURE, SALE, DELIVERY, RESALE, REPAIR OR USE OF ANY PRODUCT COVERED BY THIS ORDER SHALL BE LIMITED TO THE PRICE APPLICABLE TO THE PRODUCT OR PART THEREOF WHICH GIVES RISE TO THE CLAIM. WHEELOCK'S LIABILITY ON ANY CLAIM OF ANY KIND SHALL CEASE IMMEDIATELY UPON THE INSTALLATION IN THE PRODUCT OF ANY PART NOT FURNISHED BY WHEELOCK. IN NO EVENT SHALL WHEELOCK BE LIABLE FOR ANY CLAIM OF ANY KIND UNLESS IT IS PROVEN THAT OUR PRODUCT WAS A DIRECT CAUSE OF SUCH CLAIM. FURTHER, IN NO EVENT, INCLUDING IN THE CASE OF A CLAIM OF NEGLIGENCE, SHALL WHEELOCK BE LIABLE FOR INCIDENTAL OR CONSEQUENTIAL DAMAGES. SOME STATES DO NOT ALLOW THE EXCLUSION OR LIMITATION OF INCIDENTAL OR CONSEQUENTIAL DAMAGES, SO THE PRECEDING LIMITATION MAY NOT APPLY TO ALL PURCHASERS.