

*Thank you for using our products.*  
**INSTALLATION INSTRUCTIONS**  
**CLUSTER SPEAKER STROBE ASSEMBLY**

*Use this product according to this instruction manual. Please keep this instruction manual for future reference.*

**MODELS:**

Model	Number of Speakers *
STH-2R24MCCH(X) STH-2G24MCCH(X)	2
STH-3R24MCCH(X) STH-3G24MCCH(X)	3
STH-4R24MCCH(X) STH-4G24MCCH(X)	4
STH-90-R24MCCH(X)	2

\* Each Speaker is a STH-15 UL Listed under UL 1480 for Speaker Appliances.  
G= Grey, R=Red (X) = Lens color (A=amber, B=blue, G=green, R=red)

**GENERAL:**

The Cluster Speaker Strobe Assembly is designed for *indoor ceiling mounting or indoor wall mounting*, in high ambient noise level environments. The Cluster Speaker Strobe is a speaker/visual alerting system, equipped with up to 4 UL Listed STH-15SR supervised horn loudspeakers and a UL Listed High Candela Strobe, mounted to a NEMA galvanized steel enclosure, 10"W X 10" L X 6"D. The Strobe is mounted to a 4" deep backbox, which is then mounted to the steel enclosure. Speakers and Strobe are pre-wired to the internal terminal block. The speakers can be wired for one or two speaker circuit operation.

The STH-15 loudspeaker provides multiple power requirements with high dBA output at each power tap. STH-15 offers a choice of field selectable taps, 1 to 15 Watts for either 25VRMS or 70VRMS audio systems. The Series STH design incorporates a compression driver, mounted on a double re-entrant horn for maximum output at minimum power across a UL rated frequency range of 400 to 4,000Hz and an anechoic range of 400 to 14,000Hz. The speaker line inputs are compatible with standard supervision of circuit wiring by a Voice Control Panel. A capacitor is wired in series with the multi-tap transformer for this purpose. Each loudspeaker meets or exceeds the UL Standard 1480 (Speakers for Fire Protective Signaling Systems).

The RSS-24MCCH Strobes can provide a non-synchronized strobe signal when connected directly to a Fire Alarm Control Panel (FACP), or provide a synchronized strobe signal when used in conjunction with a Sync Module (SM) or Dual Sync Module (DSM). The Series RSS Strobe Appliances are UL Listed under Standard 1971 (Emergency Devices for the Hearing Impaired) for Indoor Fire Protection Service. The Series RSS Strobe Appliance with amber, blue, green or red lens is UL Listed under Standard 1638 (Visual Signaling Appliance) for Private Mode Emergency General Utility Signaling. The strobe uses a Xenon flashtube with solid state circuitry enclosed in a rugged Lexan® lens to provide maximum visibility and reliability for effective visible signaling. All inputs are polarized for compatibility with standard reverse polarity supervision of circuit wiring by a FACP.

**NOTE:** "Lexan" is a registered trademark of General Electric Company.

For additional information, see the Installation Instruction Sheet P82697 for the STH-15, P84442 for the RSS-24MCCH or the P84517 for the RSS-24MCCH with colored lens.

**NOTE:** All **CAUTIONS** and **WARNINGS** are identified by the symbol . All warnings are printed in bold capital letters.

 **WARNING: PLEASE READ THESE INSTRUCTIONS CAREFULLY. FAILURE TO COMPLY WITH ANY OF THE FOLLOWING INSTRUCTIONS, CAUTIONS AND WARNINGS COULD RESULT IN IMPROPER APPLICATION, INSTALLATION AND/OR OPERATION OF THESE PRODUCTS IN AN EMERGENCY SITUATION, WHICH COULD RESULT IN PROPERTY DAMAGE, SERIOUS INJURY OR DEATH TO YOU AND/OR OTHERS.**

**INSTALLATION INSTRUCTIONS:**

**SPEAKER WATTAGE SELECTOR SWITCH SETTING:** (See Installation Sheet P82697)

1. Remove the cable entrance interface adaptor and gasket.
2. Adjust the Speaker Wattage Selector Switch for the desired dB and wattage setting for each speaker.
3. Replace the cable entrance interface adaptor and gasket.

**MOUNTING INSTRUCTIONS:**

1. Loosen the 4 Phillips screws holding the cover plate and the RSS-24MCCH Strobe to the enclosure box. (See Figure 1)
2. Remove the cover plate.
3. Mount the speaker assembly to the desired location.
4. Punch out desired knockouts and attach conduit and fittings.
5. Connect all field wiring as per wiring information in Figure 3 or 4.
6. Replace cover plate to the enclosure box and tighten the 4 Phillips screws.
7. Adjust the angle for the speakers to point to the desired direction. Be sure that the speakers do not block the strobe view. (See Figure 5)

**Figure 1: Phillips Screw Location**

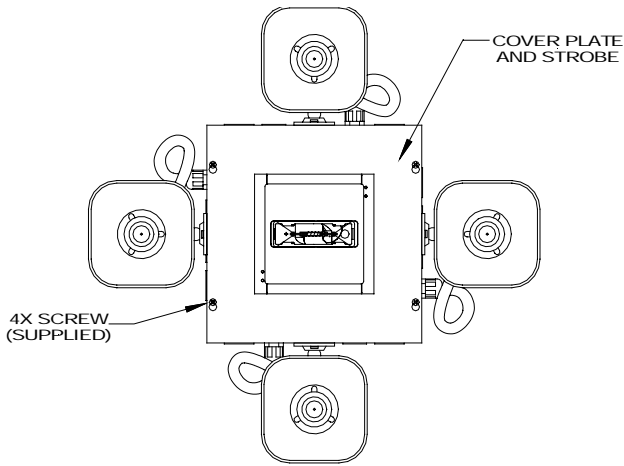

**Figure 2: Speaker Numbering**

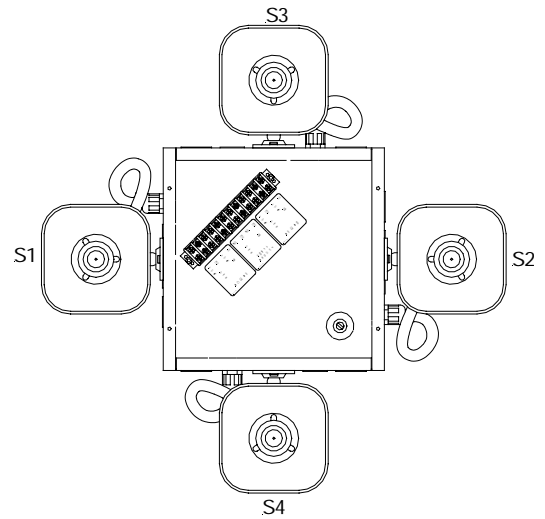

Model	Circuit 1	Circuit 2
STH-2R24MCCH	S1	S2
STH-2G24MCCH		
STH-3R24MCCH	S1, S2	S3
STH-3G24MCCH		
STH-4R24MCCH	S1, S2	S3, S4
STH-4G24MCCH		
STH-90-R24MCCH	S1	S3

**WIRING INFORMATION:**

**Figure 3: Wiring Diagram for Two Audio Circuits**

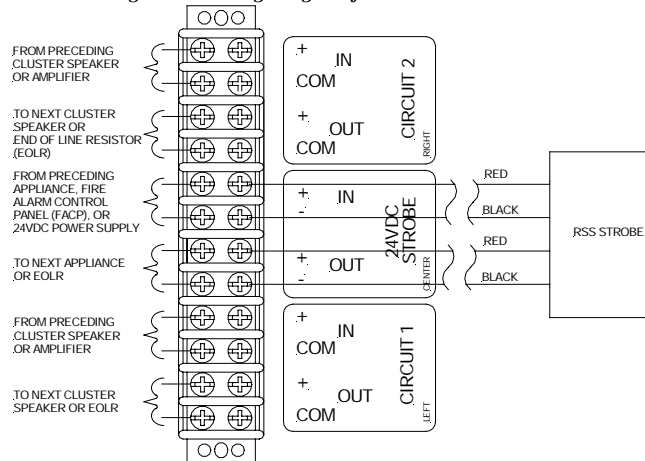

**Figure 4: Wiring Diagram for One Audio Circuits**

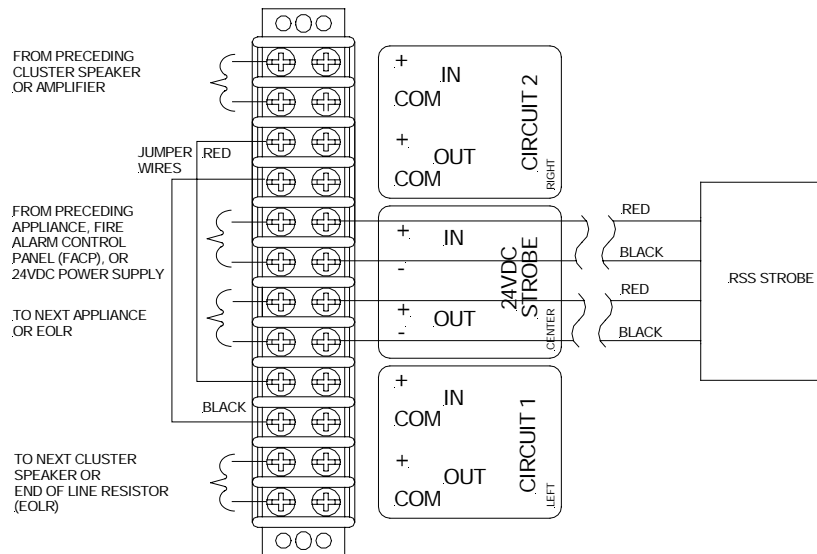

**NOTES:**

1. Strip leads 3/8 inches and connect to screw terminals. Cluster Speaker Strobes have in-out wiring terminals that accepts two #12 to #18 American Wire Gauge (AWG) wires at each screw terminal.
2. Break all in-out wire runs on supervised circuits to assure integrity of circuit supervision. The polarity shown in the wiring diagram is for operation of the appliances. The polarity is reversed by the Fire Alarm Control Panel (FACP) during supervision.
3. All models are for indoor use with a temperature range of +32° F to +120° F (0° C to +49° C) and maximum humidity of 85% RH.

*Figure 5: Cluster Speaker Strobe Unit*

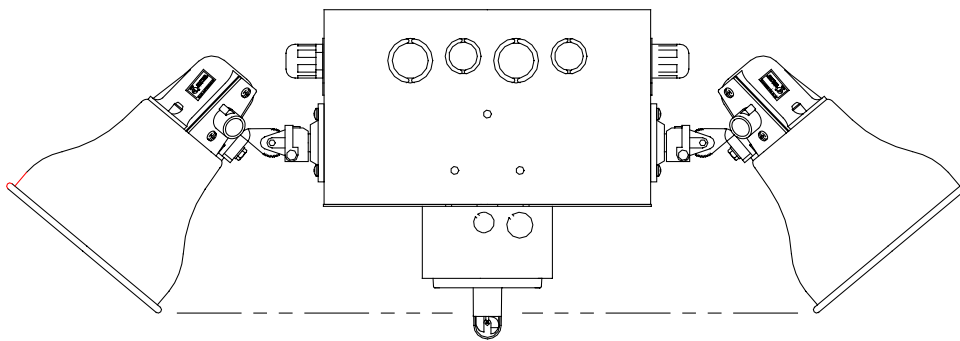

**CAUTION:** If Cluster Speaker Strobe assemblies are operated within 10 Feet of a person's ear, they can produce a sound pressure level that exceeds the maximum 120dBA permitted by NFPA and OSHA rules. Exposure to such sound levels can result in damage to a person's hearing.

**CAUTION:** Always operate audio amplifiers and speakers within their specified ratings. Excessive input may distort sound quality and may damage audio equipment. Do not exceed +130% of speaker input voltage per UL 1480. Improper input voltage can damage speaker. If distortion is heard, check for clipping of the audio appliance with an oscilloscope and reduce the amplifier input level or gain level to eliminate any clipping.

**CAUTION:** Check the installation instructions of the manufacturers of other equipment used in the system for any guidelines or restrictions on wiring and/or locating Notification Appliance Circuits (NAC) and notification appliances. Some system communication circuits and/or audio circuits, for example, may require special precautions to assure electrical noise immunity (e.g. audio cross talk).

**ANY MATERIAL EXTRAPOLATED FROM THIS DOCUMENT OR FROM COOPER WHELOCK MANUALS OR OTHER DOCUMENTS DESCRIBING THE PRODUCT FOR USE IN PROMOTIONAL OR ADVERTISING CLAIMS, OR FOR ANY OTHER USE, INCLUDING DESCRIPTION OF THE PRODUCT'S APPLICATION, OPERATION, INSTALLATION AND TESTING IS USED AT THE SOLE RISK OF THE USER AND COOPER WHELOCK WILL NOT HAVE ANY LIABILITY FOR SUCH USE.**

*Limited Warranty*

Cooper Wheelock, Inc. products must be used within their published specifications and must be PROPERLY specified, applied, installed, operated, maintained, and operationally tested in accordance with these instructions at the time of installation and at least twice a year or more often in accordance with local, state and federal codes, regulations and laws. Specification, application, installation, operation, maintenance, and testing must be performed by qualified personnel for proper operation in accordance with all of the latest National Fire Protection Association (NFPA), Underwriters' Laboratories (UL), Underwriters' Laboratories of Canada (ULC), National Electrical Code (NEC), Occupational Safety and Health Administration (OSHA), local, state, county, province, district, federal and other applicable building and fire standards, guidelines, regulations, laws and codes including, but not limited to, all appendices and amendments and the requirements of the local authority having jurisdiction (AHJ). Cooper Wheelock, Inc. products when properly specified, applied, installed, operated, maintained, and operationally tested as provided above are warranted against mechanical and electrical defects for a period of three years from date of manufacture (as determined by date code). Correction of defects by Cooper Wheelock, Inc providing repairs or a replacement shall be at Cooper Wheelock, Inc.'s sole discretion and shall constitute fulfillment of all warranty obligations. The foregoing limited warranty shall immediately terminate in the event any part not furnished by Cooper Wheelock, Inc. is installed in the product. The foregoing limited warranty specifically excludes any software required for the operation of or included in a product. COOPER WHEELOCK, INC. MAKES NO REPRESENTATION OR WARRANTY OF ANY OTHER KIND, EXPRESS, IMPLIED OR STATUTORY WHETHER AS TO MERCHANTABILITY, FITNESS FOR A PARTICULAR PURPOSE OR ANY OTHER MATTER.

Users are solely responsible for determining whether a product is suitable for the user's purposes, or whether it will achieve the user's intended results. There is no warranty against damage resulting from misapplication, improper specification, abuse, accident, or other operating conditions beyond Cooper Wheelock, Inc.'s control.

Some Cooper Wheelock, Inc. products contain software. With respect to those products, Cooper Wheelock, Inc. does not warranty that the operation of the software will be uninterrupted or error-free or that the software will meet any other standard of performance, or that the functions or performance of the software will meet the user's requirements. Cooper Wheelock, Inc. shall not be liable for any delays, breakdowns, interruptions, loss, destruction, alteration, or other problems in the use of a product arising out of or caused by the software.

The liability of Cooper Wheelock, Inc. arising out of the supplying of a product, or its use, whether based on warranty, negligence, or otherwise, shall not in any case exceed the cost of correcting defects as stated in the limited warranty and upon expiration of the warranty period all such liability shall terminate. Cooper Wheelock, Inc. is not liable for labor costs incurred in removal, reinstallation, or for damage of any type whatsoever, including but not limited to, loss of profit or incidental or consequential damages. The foregoing shall constitute the sole remedy of the purchaser and the exclusive liability of Cooper Wheelock, Inc.

In no case will Cooper Wheelock, Inc.'s liability exceed the purchase price paid for a product.

#### *Limitation of Liability*

Cooper Wheelock, Inc.'s liability on any claim of any kind, including negligence, breach of warranty, or otherwise, for any loss or damage resulting from, arising out of, or connected with any contract, or from the manufacture, sale, delivery, resale, repair or use of any product shall be limited to the price applicable to the product or part thereof which gives rise to the claim. Cooper Wheelock, Inc.'s liability on any claim of any kind shall cease immediately upon the installation in the product of any part not furnished by Cooper Wheelock, Inc. In no event shall Cooper Wheelock, Inc. be liable for any claim of any kind unless it is proven that our product was a direct cause of such claim. **FURTHER, IN NO EVENT, INCLUDING IN THE CASE OF A CLAIM OF NEGLIGENCE, SHALL COOPER WHEELOCK, INC. BE LIABLE FOR INCIDENTAL, INDIRECT, SPECIAL OR CONSEQUENTIAL DAMAGES.** Some states do not allow the exclusion or limitation of incidental or consequential damages, so the preceding limitation may not apply to all purchasers.