



273 Branchport Avenue
Long Branch, N.J. 07740
(800) 631-2148
www.wheelockinc.com

Thank you for using our products.
INSTALLATION INSTRUCTIONS
TONE GENERATOR WITH MUTE

Use this product according to this instruction manual. Please keep this instruction manual for future reference.

MODEL: TGM-300

APPLICATION INFORMATION

Wheelock Inc. manufactures high quality telephone products. The installation of this product must conform to the following instruction. IF ANY WORDS OR LETTERS APPEAR ON THE PRODUCT INDICATION A PARTICULAR USE, THE PRODUCT MUST BE USED ONLY IN THE MANNER SO INDICATED. THE INSTALLATION OF THIS EQUIPMENT SHOULD ONLY BE UNDERTAKEN BY QUALIFIED PERSONNEL. FIELD ADJUSTMENT, REPAIR OR MODIFICATION OF THESE SIGNALS SHOULD NOT BE ATTEMPTED. Malfunctioning units should be returned for factory repair or replacement in accordance with Wheelock Inc.'s published terms and conditions

NOTE: All **CAUTIONS** and **WARNINGS** are identified by the symbol . All warnings are printed in bold capital letters.

 **CAUTION:** The installation of this equipment should only be undertaken by qualified personnel.

 **WARNING: SHUT OFF ALL POWER BEFORE INSTALLING. ELECTRICAL SHOCK CAN CAUSE DEATH OR SERIOUS INJURY.**

 **WARNING: READ THESE INSTRUCTIONS CAREFULLY. FAILURE TO COMPLY WITH ANY OF THE FOLLOWING INSTRUCTIONS, CAUTIONS AND WARNINGS COULD RESULT IN IMPROPER APPLICATION, INSTALLATION AND/OR OPERATION OF THESE PRODUCTS IN AN EMERGENCY SITUATION, WHICH COULD RESULT IN PROPERTY DAMAGE AND SERIOUS INJURY OR DEATH TO YOU AND/OR OTHERS.**

FCC REGULATIONS

- This equipment complies with Part 68 of the FCC Rules. The label affixed to this product contains, among other information, the FCC Registration Number and the Ringer Equivalence Number (REN) for this product. This information must be provided to the telephone company if requested.
- The REN is used to determine the quantity of devices which you may connect to your telephone line and still have all of those devices ring when your telephone number is called. In most, but not all areas, the sum of the REN's of all devices connected to one line should not exceed five (5.0). To be certain of the number of devices that you may connect to your line, contact your local telephone company.
- This equipment should not be used on coin telephone lines. Connection to party line service is subject to state tariffs.
- If trouble is experienced, disconnect this equipment from the telephone line to determine if it is causing the malfunction. If the equipment is determined to be malfunctioning, its use shall be discontinued until the problem has been corrected.
- Should the equipment cause harm to the telephone network, the telephone company shall, if possible, notify the customer that temporary discontinuance of service may be required; however, where prior written notice is not possible, the telephone company may temporarily discontinue service without notice, if such action is necessary under the circumstances. The telephone company may make changes in its communication facilities, equipment and operations procedures, where such action is reasonably required in the operation of its business and is not inconsistent with the rules and regulations of the Federal Communications Commission.

DOC REGULATIONS

NOTICE: The Canadian Department of Communications label identifies certified equipment. This certification means that the equipment meets certain telecommunications network protective operational and safety requirements. The Department does not guarantee the equipment will operate to the users' satisfaction.

- Before installing this equipment, users should ensure that it is permissible to be connected to the facilities of the local telecommunications company. The equipment must also be installed using an acceptable method of connection. In some cases, the company's inside wiring associated with a single line individual service may be extended by means of a certified connector assembly (telephone extension cord). The customer should be aware that compliance with the above conditions may not prevent degradation of service in some situation.
- Any repairs or alterations made by the user to this equipment, or equipment malfunctions, may give the telecommunications company cause to request the user to disconnect the equipment.
- Make sure that the electrical ground connections of the power utility, telephone lines and internal metallic water pipe system, if present, are connected together.
- **CAUTION:** The installation of this equipment should only be undertaken by qualified personnel.
- The Load Number (LN) assigned to each terminal device denotes the percentage of the total load to be connected to a telephone loop which is used by the device, to prevent overloading. The termination on a loop may consist of any combination of devices subject only to the requirement that the total of the Load Numbers of all the devices does not exceed 100.

Load Number for TGM-300 = 6

Copyright 1987, 1992 Wheelock Inc. All rights reserved.

GENERAL INFORMATION

The Tone Generator portion of the module provides a pleasant chime signal when used with existing or newly installed paging systems. It is designed for use on the public telephone network or behind PBX and key systems that use interrupted or continuous ringing voltages from 40-130VAC, 20-30Hz. It is also designed for use with telephone communications systems whose ringing voltages are from 18 to 30 Volts AC/DC or those that supply a continuous or pulsed contact closure.

The Tone Generator produces a single chime sound once every second. Both the tone and the sound level are adjustable.

The muting portion of the module can be used to control 3 paging zones. If there is an incoming call the module will switch off the background music and generate a pleasant chime tone over the paging system. See Figure 1 below.

Figure 1. Simplified Schematic

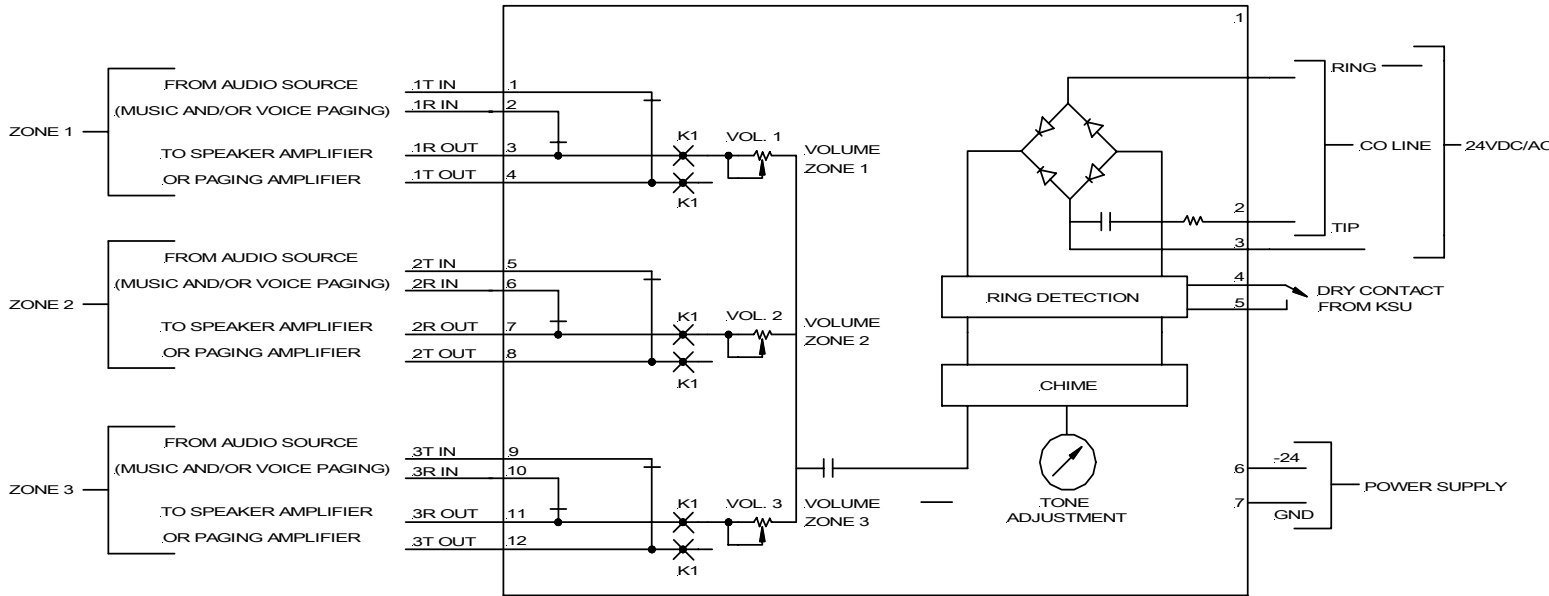

To power the TGM-300 a 24 Volt power source is required. Wheelock's EPS-2401 power supply will power the TGM-300. The unit is intended for indoor use only

SPECIFICATIONS:

<i>Table 1.</i>		
Nominal Signal Input	90VRMS, 20Hz	24VAC/DC Contact Closure
Signal Input Range	40-130VRMS, 20-30Hz	18-30VAC/DC
Signal Current	5mA	7mA 10mA at 24VDC
Ringer Equivalence	0.4A	-----
Voice Impedance	30K OHMS at 3VRMS, 400Hz	-----
Power Input Voltage	24VDC	
Power Input Current	50mA	
Minimum Ring Cycle:		
On Time	<u>0.8 Seconds</u>	<u>0.5 Seconds</u>
Off Time	<u>2 Seconds</u>	<u>0.5 Seconds</u>
Minimum Chime Frequency	700Hz	
Maximum Chime Frequency	1200Hz	
Termination	Terminals	
Output Impedance (T&R)	1000 Ohms	
Output Level	-15 dBm to +10 dBm	

INSTALLATION INFORMATION

The TGM-300 is designed for mounting near the PBX or the telephone key system. Remove the top cover by pushing on the latch at the bottom of the box with a screwdriver. See Figure 2.

Mount the bottom of the box with the PCB assembly to the wall with the two mounting screws that are provided.

CAUTION: These devices are not intended for use in hazardous locations as defined by the national electrical code (NEC) and by the National Fire Protection Association (NFPA).

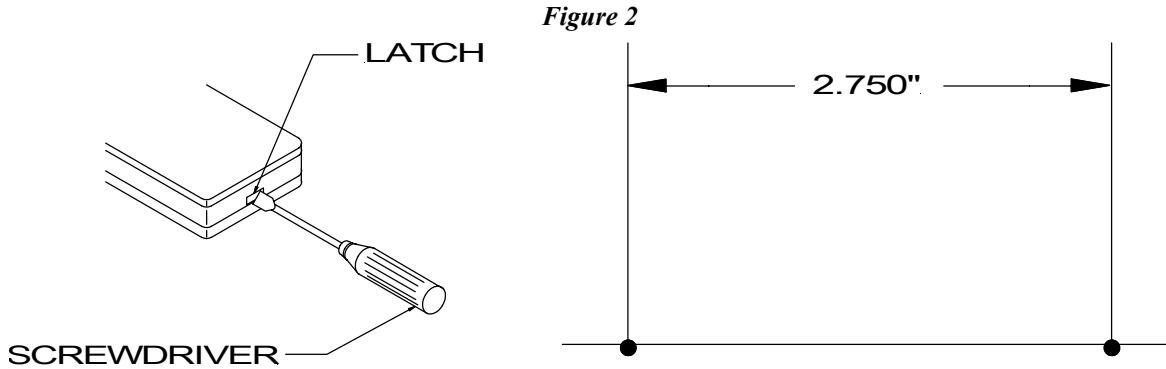

NOTE: Mounting Template not to scale.

WIRING (SEE FIGURE 3)

CAUTION: USE CLASS 2 POWER SOURCE ONLY.

Figure 3. Wiring Diagram

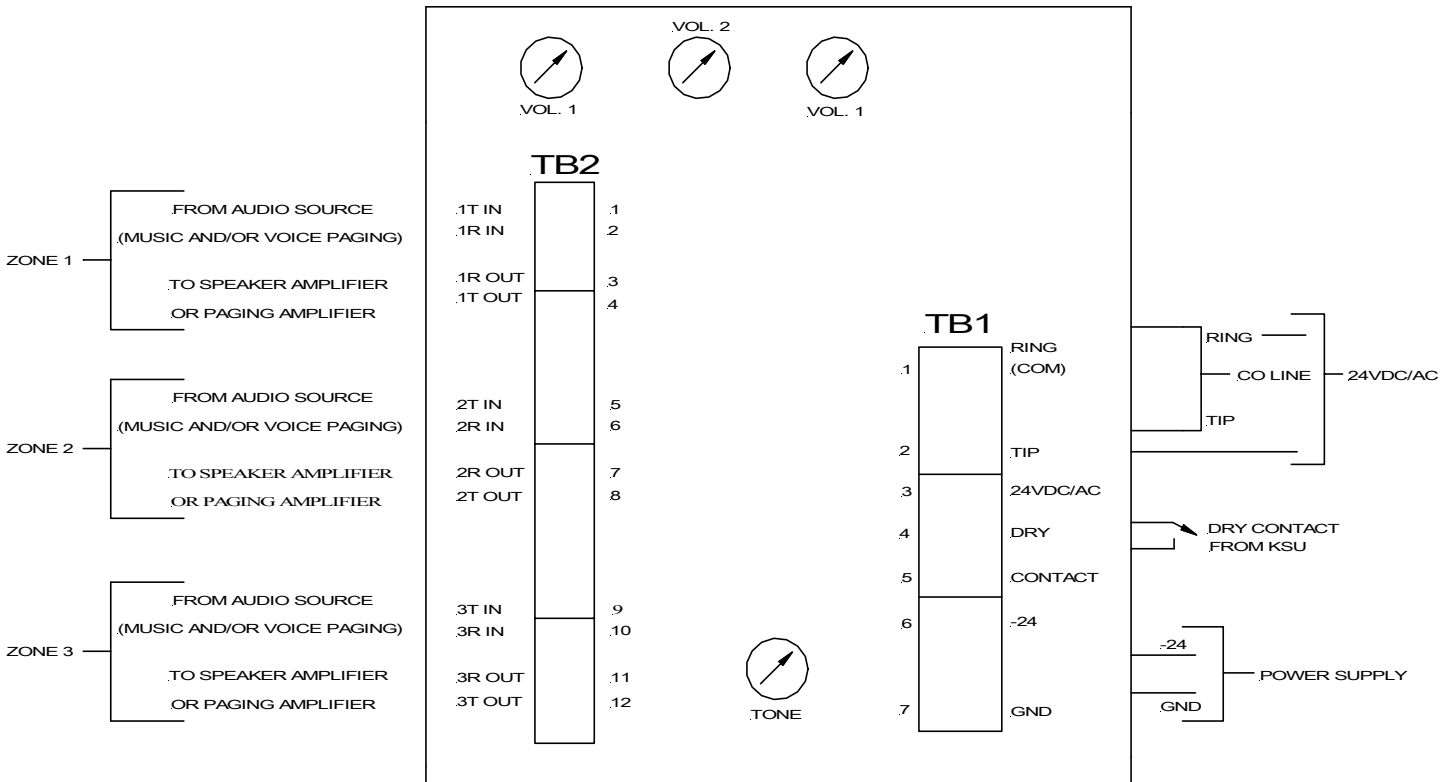

- Connect C.O. Tip and Ring to TB1, Terminals 2 and 1 - OR - connect 18-30VAC/DC to TB1, Terminals 3 and 1 - OR - connect closure to TB1, Terminals 4 and 5. (Do not connect more than one of these optional input.)
- For Zone 1: Connect speaker amplifiers or paging amplifier to TB2, Terminals 3 and 4. Connect and audio source (music and/or voice paging) to TB2, Terminals 1 and 2. Zone 2 and 3 hook up in a similar fashion. The maximum speaker capacity of all 3 zones combined is 10 speaker amplifiers. This capacity can be expanded up to 150 speaker amplifiers per zone when used with Wheelock Inc's Model PRM-150, Pre Amp Module.
- Make sure the 24VDC power supply is disconnected, then connect positive (+) and negative (-) to TB1, Terminals 7 (GND) and 6 (-24) respectively.
- Recheck all wiring and then connect the power supply.
- Activate the unit by ringing the phone and slowly adjust the volume control of each individual zone to the desires level.
- Adjust Tone for desired sound.

TROUBLING SHOOTING CHART

Condition	Check
No Sound to Speaker	1) Check presence and polarity of 24VDC and GND. 2) Check for proper ring signal or dry contact closure at the input. 3) Check audio presence at T out and R out for zone 1, zone 2, and zone 3. 4) Check audio presence at the input of speaker amplifier or paging amplifier. If yes then go to 5. 5) Check for proper DC voltage presence at the speaker amplifier or check the paging amplifier instruction manual.
Low Volume to Speaker	1) Turn up volume controls (clockwise). Check the volume controls at speaker amplifier or paging amplifier is turned up.
Overdrives Amplifiers	1) Turn the volume controls counter clockwise until obtaining the proper chime sound. If necessary check the volume control at the amplifiers.

ANY MATERIAL EXTRAPOLATED FROM THIS DOCUMENT OR FROM WHEELOCK MANUALS OR OTHER DOCUMENTS DESCRIBING THE PRODUCT FOR USE IN PROMOTIONAL OR ADVERTISING CLAIMS, OR FOR ANY OTHER USE, INCLUDING DESCRIPTION OF THE PRODUCT'S APPLICATION, OPERATION, INSTALLATION AND TESTING IS USED AT THE SOLE RISK OF THE USER AND WHEELOCK WILL NOT HAVE ANY LIABILITY FOR SUCH USE.

IMPORTANT: READ SEPARATE "GENERAL INFORMATION" SHEET FOR INFORMATION OF THE PLACEMENT, LIMITATIONS, INSTALLATION, FINAL CHECKOUT, AND PERIODIC TESTING OF NOTIFICATION APPLIANCES.

⚠ CAUTION: Check the installation instructions of the manufacturers of other equipment used in the system for any guidelines or restrictions on wiring and/or locating Notification Appliance Circuits (NAC) and notification appliances. Some system communication circuits and/or audio circuits, for example, may require special precautions to assure electrical noise immunity (e.g. audio crosstalk).

NOTE: This equipment has been tested and found to comply with the limits for a Class B digital appliance, pursuant to Part 15 of the FCC Rules. These limits are designed to provide reasonable protection against harmful interference in residential installation. This equipment generates, uses and can radiate radio frequency energy and, if not installed and used in accordance with the instructions, may cause harmful interference to radio communications. However, there is no guarantee that interference will not occur in a particular installation. If this equipment does cause harmful interference to radio or television reception, which can be determined by turning the equipment off and on, the user is encouraged to try to correct the interference by one or more of the following measures: 1) Reorient or relocate the receiving antenna, 2) Increase the separation between the equipment and receiver, 3) Connect the equipment into an outlet on a circuit different from that to which the receiver is connected, and 4) Consult the dealer or an experienced radio/TV technician for help.

Limited Warranty

Wheelock products must be used within their published specifications and must be PROPERLY specified, applied, installed, operated, maintained and operationally tested in accordance with these instructions at the time of installation and at least twice a year or more often and in accordance with local, state and federal codes, regulations and laws. Specification, application, installation, operation, maintenance and testing must be performed by qualified personnel for proper operation in accordance with all of the latest National Fire Protection Association (NFPA), Underwriters' Laboratories (UL), Underwriters' Laboratories of Canada (ULC), National Electrical Code (NEC), Occupational Safety and Health Administration (OSHA), local, state, county, province, district, federal and other applicable building and fire standards, guidelines, regulations, laws and codes including, but not limited to, all appendices and amendments and the requirements of the local authority having jurisdiction (AHJ). Wheelock products when properly specified, applied, installed, operated, maintained and operationally tested as provided above are warranted against mechanical and electrical defects for a period of three years from date of manufacture (as determined by date code). Correction of defects by repair or replacement shall be at Wheelock's sole discretion and shall constitute fulfillment of all obligations under this warranty. THE FOREGOING LIMITED WARRANTY SHALL IMMEDIATELY TERMINATE IN THE EVENT ANY PART NOT FURNISHED BY WHEELOCK IS INSTALLED IN THE PRODUCT. THE FOREGOING LIMITED WARRANTY SPECIFICALLY EXCLUDES ANY SOFTWARE REQUIRED FOR THE OPERATION OF OR INCLUDED IN A PRODUCT. WHEELOCK MAKES NO REPRESENTATION OR WARRANTY OF ANY OTHER KIND, EXPRESS, IMPLIED OR STATUTORY WHETHER AS TO MERCHANTABILITY, FITNESS FOR A PARTICULAR PURPOSE OR ANY OTHER MATTER.

USERS ARE SOLELY RESPONSIBLE FOR DETERMINING WHETHER A PRODUCT IS SUITABLE FOR THE USER'S PURPOSES, OR WHETHER IT WILL ACHIEVE THE USER'S INTENDED RESULTS. THERE IS NO WARRANTY AGAINST DAMAGE RESULTING FROM MISAPPLICATION, IMPROPER SPECIFICATION, ABUSE, ACCIDENT OR OTHER OPERATING CONDITIONS BEYOND WHEELOCK'S CONTROL.

SOME WHEELOCK PRODUCTS CONTAIN SOFTWARE. WITH RESPECT TO THOSE PRODUCTS, WHEELOCK DOES NOT WARRANT THAT THE OPERATION OF THE SOFTWARE WILL BE UNINTERRUPTED OR ERROR-FREE OR THAT THE SOFTWARE WILL MEET ANY OTHER STANDARD OF PERFORMANCE, OR THAT THE FUNCTIONS OR PERFORMANCE OF THE SOFTWARE WILL MEET THE USER'S REQUIREMENTS. WHEELOCK SHALL NOT BE LIABLE FOR ANY DELAYS, BREAKDOWNS, INTERRUPTIONS, LOSS, DESTRUCTION, ALTERATION, OR OTHER PROBLEMS IN THE USE OF A PRODUCT ARISING OUT OF OR CAUSED BY THE SOFTWARE.

THE LIABILITY OF WHEELOCK ARISING OUT OF THE SUPPLYING OF A PRODUCT, OR ITS USE, WHETHER ON WARRANTIES, NEGLIGENCE, OR OTHERWISE, SHALL NOT IN ANY CASE EXCEED THE COST OF CORRECTING DEFECTS AS STATED IN THE LIMITED WARRANTY AND UPON EXPIRATION OF THE WARRANTY PERIOD ALL SUCH LIABILITY SHALL TERMINATE. WHEELOCK IS NOT LIABLE FOR LABOR COSTS INCURRED IN REMOVAL, REINSTALLATION OR REPAIR OF THE PRODUCT BY ANYONE OTHER THAN WHEELOCK OR FOR DAMAGE OF ANY TYPE WHATSOEVER, INCLUDING BUT NOT LIMITED TO, LOSS OF PROFIT OR INCIDENTAL OR CONSEQUENTIAL DAMAGES. THE FOREGOING SHALL CONSTITUTE THE SOLE REMEDY OF THE PURCHASER AND THE EXCLUSIVE LIABILITY OF WHEELOCK.

IN NO CASE WILL WHEELOCK'S LIABILITY EXCEED THE PURCHASE PRICE PAID FOR A PRODUCT.

Limitation of Liability

WHEELOCK'S LIABILITY ON ANY CLAIM OF ANY KIND, INCLUDING NEGLIGENCE AND BREACH OF WARRANTY, FOR ANY LOSS OR DAMAGE RESULTING FROM, ARISING OUT OF, OR CONNECTED WITH THIS CONTRACT, OR FROM THE MANUFACTURE, SALE, DELIVERY, RESALE, REPAIR OR USE OF ANY PRODUCT COVERED BY THIS ORDER SHALL BE LIMITED TO THE PRICE APPLICABLE TO THE PRODUCT OR PART THEREOF WHICH GIVES RISE TO THE CLAIM. WHEELOCK'S LIABILITY ON ANY CLAIM OF ANY KIND SHALL CEASE IMMEDIATELY UPON THE INSTALLATION IN THE PRODUCT OF ANY PART NOT FURNISHED BY WHEELOCK. IN NO EVENT SHALL WHEELOCK BE LIABLE FOR ANY CLAIM OF ANY KIND UNLESS IT IS PROVEN THAT OUR PRODUCT WAS A DIRECT CAUSE OF SUCH CLAIM. FURTHER, IN NO EVENT, INCLUDING IN THE CASE OF A CLAIM OF NEGLIGENCE, SHALL WHEELOCK BE LIABLE FOR INCIDENTAL OR CONSEQUENTIAL DAMAGES. SOME STATES DO NOT ALLOW THE EXCLUSION OR LIMITATION OF INCIDENTAL OR CONSEQUENTIAL DAMAGES, SO THE PRECEDING LIMITATION MAY NOT APPLY TO ALL PURCHASERS.