

Tools for Gridcrash

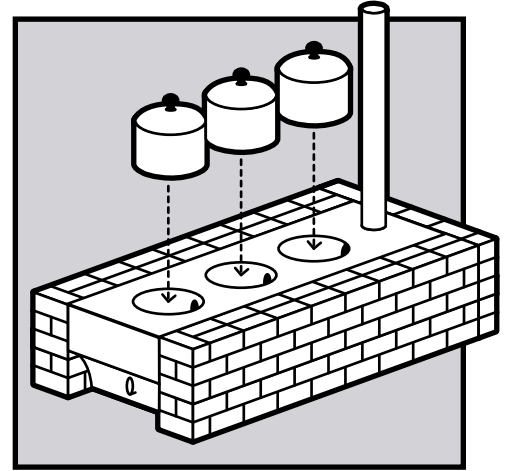

IN THE WAKE

A collective manual-in-progress for outliving civilization

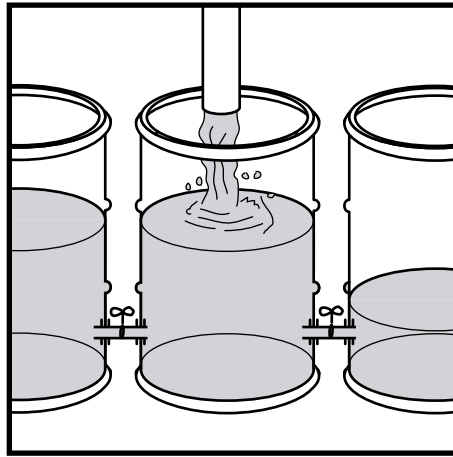
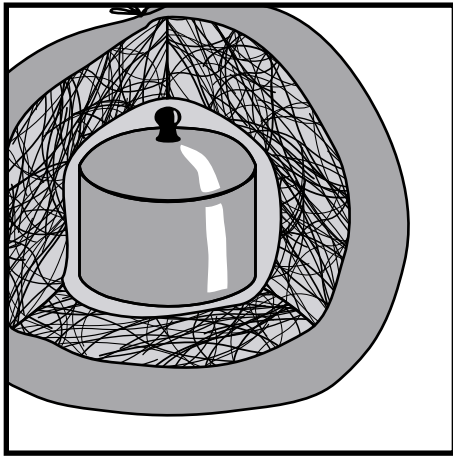
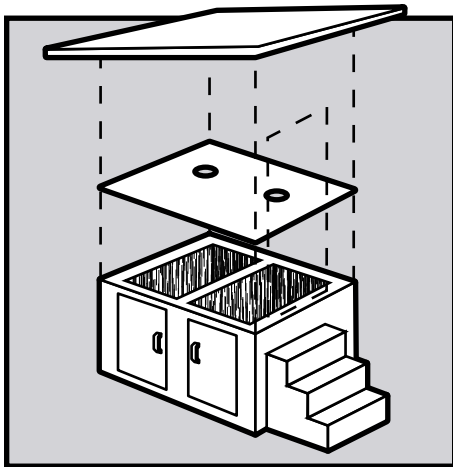

Excerpt Booklet 1

Aric McBay

Contents

i	Introduction	20		
i	Premises	20		Greywater
iii	The Purpose of this Booklet	20		Greywater Pit
v	Acknowledgements	20		Branching System
vi	Further Reading	20		Greywater Notes
1	Water	21	A note on Heat	
1	Contamination	22		
2	Groundwater	22	Cool Food Storage	
2	Wells	22	A note on Food Safety	
4	Springs	23	Water Immersion	
4	Rainwater and Snow Collection	24	Cold Room	
7	Surface Water Collection	25	In-ground Cooling	
7	Survival Sources	25	Ice Caves / Ice Houses	
7	Dug Still	26	Ice Boxes	
7	Transpiration	26	Vapour Pantry / Pot-in-pot Cooler	
7	Dew and Condensation	27	Salvaged and Modified Refrigerators	
8	Water in Plants	27	Cooling Notes:	
8	Observing other Animals	28	Cooking	
8	Water Treatment	29	Hayboxes	
8	Simple Treatments	29	Efficient Wood-Burning	
8	Straining	29	Open Fires	
8	Aeration	29	Building an open fire	
9	Storage	30	Three stone fire	
9	Disinfection	30	Hearth variations	
9	Disinfection by Boiling	30	Fire hole	
9	Chemical Disinfection	31	Efficient Woodstoves	
10	Solar Disinfection	31	Winiarski Rocket Stove	
10	Distillation	33	Dona Justa Stove	
12	Sand Filters	33	Solar cooking	
12	Slow Sand Filters	35	Simple folding solar cooker	
14	Rapid Sand Filters	38	Solar Oven	
14	General Water Notes	38	Parabolic cooker	
15	Latrines and Greywater	39	Biodigested Methane	
15	Latrines	39	Cooking Notes	
15	Siting Latrines	39	Quick Lighting and Heat	
15	Pit Latrines	39	Lighting	
15	Trench Latrines	40	Oil Lamp	
16	Ventilated Improved Pit Latrines	40	Candles	
16	Other Options	40	Rush Light	
17	General Latrine Notes	40	Buddy Burner	
17	Composting Toilets	40	Reflectors	
18	The Jenkins Sawdust Toilet	40	Improvisation Exercises	
19	The Two Chamber Toilet	41	Lighting Notes:	
19	Variations	42	Heating	
20	Composting Toilet Notes	42	Notes	
			Rubbish	
			Garbage and Recycling Collection	

Introduction

This booklet is an excerpt from a larger book project which is in the works, called “In the Wake: A Collective Manual-in-Progress for Outliving Civilization.” This project, and my writings and life in general, are based on the premise that industrial civilization is destroying the world and exploiting and murdering the inhabitants of the world. I believe that industrial civilization is not capable of doing anything else, whatever political party (or corporation, or American-installed military dictator) is “in charge”.

I want to help to create communities which are equitable, ecological, and sustainable. I also believe that we can't do this within the machinery of industrial civilization. More to the point, that machinery is insatiable, imperialistic, and in the end, suicidal. Civilization is destroying itself along with the world.

This introduction is necessarily brief, but I encourage you to look at some of the resources at the end of this introduction to learn more about the assumptions this book is based on.

Premises

Let me be specific about what I mean by industrial civilization. For many people, the word civilization calls to mind words like “refined, safe, convenient, modern, advanced, polite, enlightened and sophisticated.” Of course, these words are the words that civilized people use to describe themselves. For example, if you look up the word “Christian” in the thesaurus, you will find words like “fair, good, high-principled, honourable, humane, noble, right, virtuous” and other words that Christians might use to describe themselves, but which hardly apply to the Crusades, the Witch-Burnings, or other such atrocities carried out by self-described Christians.

For a more unbiased definition of civilization, we can consider historian Lewis Mumford's use of the word civilization “to denote the group of institutions that first took form under kingship. Its chief features, constant in varying proportions throughout history, are the centralization of political power, the separation of classes, the

lifetime division of labor, the mechanization of production, the magnification of military power, the economic exploitation of the weak, and the universal introduction of slavery and forced labor for both industrial and military purposes.”¹

Anthropologist Stanley Diamond cuts to the chase, and says simply that “Civilization originates in conquest abroad and repression at home.”²

By “industrial”, I mean a society that is dependent on machines for the basics of life. A society that needs tractors to grow food, trucks to transport it, factories to synthesize fertilizers, and so on, is an industrial society. A society where people participate in the growing of their own food and other basics by hand would not be industrial.

Put the two concepts together and you get industrial civilization. This is a society with an extreme disparity of power, and where machines are built, and humans mechanized, in order to serve the needs of those in power. Since those in power want, essentially, to become more powerful, society is caught in the claws of powerful people who constantly seek to accelerate and extend the exploitation of human beings and the natural world. We can see the effects of this in the intense global destruction of the living world.

That the world is being destroyed probably isn't news to you. You've probably heard that 90% of the fish in the ocean have been killed in the past 50 years, and that those remaining are significantly smaller.³ You've probably heard that the oceans are in a state of ecological collapse. And that phytoplankton, the basis of the biosphere, has decreased in global population by 6% in a mere two decades, and by as much as 30% in some areas.⁴ Populations of krill, the tiny animals just above phytoplankton on the ocean food chain, are down by 80% in three decades.⁵ You've probably read in the news that global warming will kill up to 37% of all species on earth by 2050⁶ (and you've probably noticed that the estimates of these casualties from global warming seem to increase just about every week). In essence, you've probably noticed, even if you only read the corporate-owned newspapers, that the world is being ever more

rapidly destroyed. If you're paying attention, you don't even need the papers to tell you this.

Many, if not most of us, realize that this rapid destruction can not continue indefinitely. A society which destroys the land will inevitably die, because all people, in the end, depend on the land for sustenance.

Industrial civilization also depends on energy-hungry machines to survive. Some people seem to believe that machines support our lives, that water comes from the tap and potatoes come from the grocery store. But machines only extract and centralize—I might go so far as to say “loot and pillage”—the natural “resources” that humans depend on. Machines don't and can't create life.

As peak-oil activists are publicizing, the amount of oil on the Earth is finite, and civilization is running out. More than half of the extractable petroleum is gone. Demand is skyrocketing because of continued growth and the industrialization of the so-called “Third World”. The supply of oil that runs and builds the machines of industrial civilization has peaked, and is now beginning the not-so-slow process of running out. For a system dependent on growth, that's a disaster.

A number of recent books examine the situation with great clarity, such as Matt Savinar's “The Oil Age is Over”, and Richard Heinberg's “The Party's Over: Oil, War, and the Fate of Industrial Societies”.

Many peoples' first impression is that we won't actually be in trouble until the oil actually runs out completely, several decades from now, but it's actually much more urgent than that. I'll use an analogy to explain.

Imagine industrial civilization as a weight which is suspended from a ceiling by many, many ropes. These ropes are the constant supplies of oil that keep civilization from crashing down.

Now imagine the weight of civilization as the energy required to deal with all of civilization's needs to keep existing -- energy to build and maintain the physical infrastructure, to transport and centralize materials and resources, to engage in war and occupation to ensure a constant supply of resources, to industrially produce food for a growing population, and so on. As those needs increase, the weight gets heavier. For example, as the water tables in agricultural areas drop, more energy

and infrastructure are required to drill deeper wells, to pump water from further away, to construct and maintain irrigation systems. Things like this increase the “weight” of civilization. And those actions tend to cause their own problems, like depletion and salinization of the soil, which will require more and more energy in the future. The weight just keeps on getting heavier.

Now, industrial civilization has managed to persist so far because it keeps getting more and more ropes -- that is, it extracting more and more oil each year. But now oil production has reached a plateau. Civilization has as many ropes as it will ever have, but it keeps getting heavier. The ropes are stretched taut, and soon they'll be stretch to the breaking point. Some time around 2007 the gap between the demand for oil and the production will become “unbridgeable”. There won't be enough oil, or ropes.

If you cut a rope in our strained example, maybe the other ropes will still be able to hold it up. But if you cut another one, and then another one, eventually the remaining ropes will be overloaded. They will all snap and the weight will fall.

But civilization isn't a single object. A more accurate analogy would look at civilization as a set of weights, which are all hanging by ropes and connected to each other by cables. Each of these weights is a segment of the interdependent industrial economy: synthetic fertilizer production, oil extraction, natural gas distribution, military arms manufacturing, and so on. And each of these weights is connected to each other by cables because they are interdependent. Fertilizer production requires ample supplies of natural gas, and reliable oil extraction depends on a stable regime backed up by a well-armed military. Once the ropes snap on one weight, it falls and pulls on the weights connected to it by cables. And then one after the other their ropes snap too, and the entire apparatus falls in ruin.

That's called a “cascading industrial collapse,” and I think it's the most likely future for industrial civilization within the next decade or so.

This knowledge is a shock that many people are unable to cope with, so they ignore it. Or they cheer for or work on energy technologies like fuel cells with which they hope to draw out the lifespan of civilization. But at the same time civilization brings them their gasoline

and electricity, it also strips away the forests that used to provide fuel and wood for anyone who lived near them. It poisons the air, water and soil, it empties the oceans of fish and destroys the sensitive balance of the Earth's climate. And as it reaches out, one foot already in the grave, to pillage the last bits of remaining "resources" it displaces and murders those human communities that have managed to survive as long as they can. Remaining indigenous groups world-wide are displaced, threatened, and assaulted to obtain more oil and minerals. Rural communities shrivel as agriculture, forestry and fishing become ever more mechanized, or simply cease to exist because of deforestation and the collapse of fisheries. Even now, already a billion people, 1 out of every 6 people on the planet, live in squalid conditions in urban slums, and that number is likely to double within the next quarter century, according to the UN.⁷

The longer industrial civilization lasts the more human and living communities it will destroy. We know that it's going to come down one day, and probably soon. The longer it exists, the worse shape we will be in. Knowing that, we realize that it is time to bite the bullet.

Industrial civilization needs to end as soon as possible.

It is my starting point that if we want to have healthy communities and landbases, which can recover from the attacks they have faced, we must first get rid of industrial civilization. You can't heal from an assault until the assault has actually ended.

Those of us who are aware of the situation are often deluged by greenwash. Those in power want us to believe that the situation can be remedied by minor fixes, by seamlessly replacing the dirty, industrial system with a "green," solar and wind-powered equivalent. But it doesn't work that way, as the references at the end of the introduction examine in great detail. The "renewables" offer only a tiny fraction of the energy required to prevent collapse. And once industrial civilization has collapsed it will be next to impossible to produce industrial "renewables" like gigantic wind turbines.

For many industrialized people, the severity of this situation is almost impossible to understand, accept, or perceive. Some people will go to any intellectual or emotional length to deny or ignore the situation, and insist that we can simply use hydrogen cars and solar powered computers without fundamentally changing

our lifestyles. This is mere wishful thinking, but those in power prefer it. If the truly dire nature of our situation were universally recognized, the economy would collapse shortly thereafter. Who would buy stocks, who would go to work, who would put their money in the bank, if they knew that in the coming years the collapse of industrial civilization was inevitable?

The situation is clearly desperate. The upward energy consumption trend and the downward availability trend will collide catastrophically. The result will be the collapse of industrial civilization, and there is nothing that anyone can do to stop it.

But there are things that people can do about it, during and after it. Which is what this book project is for.

Because some people identify very closely with industrial civilization, the thought of its collapse seems like their own death. They can not imagine that anything might happen afterwards. But the collapse, in theory, doesn't necessarily have to be very violent, and could ideally involve less deprivation and poverty than now exist. This would require an honest look at the situation by everyone. It would mean scaling down industrial capacity as rapidly as possible, and focusing efforts on ensuring that as many people as possible are fed and healthy, instead of trying to create hydrogen cars or other false hopes.

However, we know that governments and corporations are not going to do this. It would be very unpopular, make very little profit, and generally distribute wealth, power and self-determination, whereas industrialization has concentrated the control of the basics of life in the hands of very few people.

The fundamental inability of the controlling institutions of society to deal appropriately with the situation puts us in a rather desperate situation. It's up to us as small, face-to-face groups (the only groups which can really be democratic or accountable, in my opinion) to do what needs to be done to ensure that things turn out as well as possible.

The Purpose of this Booklet

Many of us are very busy with making a living, taking care of ourselves and each other, doing activism and so on. We can't all spend as much time as we'd like camping

in the forest, growing gardens, learning improvised wilderness first aid, or learning other skills for collapse. And the likely timeline for collapse is staggeringly short. We can expect massive disruptions of global industrial and transportation systems starting between 2005 and 2010.⁸ One of the reasons that I am writing this is for it to be a “crash course” for the crash, a way of quickly introducing a variety of important skills and technologies to people who aren’t familiar with them, as well as creating a reference and resource for those who are.

It’s difficult to predict exactly how the collapse will play out (although Planning, Prediction and Preparation is the subject of the next *In the Wake* excerpt booklet). The collapse of various civilizations in history took years or decades to collapse. So looking at those examples, it’s tempting to go back to sleep and say “don’t worry, we have plenty of time to figure out how to deal with collapse. It will happen gradually.” But that’s far from guaranteed. Those civilizations took centuries or millennia to reach their full extent. The dominant technological civilization on the planet is dependent on machines that are only decades old. The time-scale of change has become profoundly compressed by rapid industrial change. We can expect the rate of collapse to reflect that compression. Also, those historical civilizations were based on technologies that were much less interdependent than ours. If the oil supply is interrupted, it becomes impossible to maintain the electrical generation and distribution infrastructure. If the electrical infrastructure goes out, then almost all of the rest of the infrastructure goes out immediately. Telecommunications may continue temporarily by generator and battery power, but even communications are becoming electrically-dependent, and hence more brittle.

Additionally, there is reason to believe that industrial collapse may happen very rapidly because of deliberate attacks on industrial infrastructure, oil and electrical infrastructure in particular. These attacks are quite common in some areas of the world already, and are becoming increasingly common in North America. (However, they are not very publicized, probably because those in power don’t want people to realize how incredibly fragile and vulnerable the infrastructure actually is.) If there was a coordinated attempt to collapse the industrial system by a small group of committed people, near-total industrial collapse could happen *very* quickly, over a period of weeks or even days.

Though it may seem ironic to some, I believe that this rapid collapse is probably the “best-case scenario” for the planet. I’m a bit of an optimist, despite the awful state of things. So I’m planning for an optimistic scenario which involves near-term, rapid industrial collapse. It’s a remote possibility that industrial civilization may continue for decades longer if it makes extensive use of destructive technologies like nuclear power and coal-seam gasification. But if it does last that long we are seriously **fucked**. I doubt that many, if any, human beings would survive, let alone most other species. And I’m not going to write a book for a world with no humans in it—who would read it? So that leaves us with the urgency of a book for the “optimistic” scenario of rapid collapse.

I wish to provide a handbook not just to help people survive industrial collapse, but to share some of the skills people will need to demolish the remnants of industrial civilization, and civilization in general, and to build egalitarian and ecological communities of their own.

The techniques covered in this book project are chosen by the following general criteria:

- They must either apply broadly and generally to a variety of bioregions, or have the potential to be exceptionally beneficial to people in some bioregions.
- They should permit a reduced impact and/or reduced consumption, rather than increasing consumption.
- They should operate with “found resources” and remnant resources as much as possible, as opposed to cultivation or metalworking, so as to maintain the wilds and minimize labour.
- They should be relatively simple, so that they can be learned quickly.
- They should be as compact as possible, to maintain the wilds (That is, a technique that allows a 1000 square foot garden to meet food needs sustainably, would generally be preferred to a 1500 square foot garden which yields the same amount of food, since the smaller garden leaves more room for wilderness. That assumes that both gardens are equally sustainable).
- They should include easy to find or make items, so as to permit rapid scaling up, democratic application, and reduced scarcity.
- Whenever possible, their use should be creative and fulfilling, rather than repetitive.
- They should be portable, and rapidly scaleable and expandable.
- It should be possible for a small group to build and maintain them.

- Wherever possible, their use should involve the degradation of remnants of the industrial system, and the rejuvenation of the land.
- Techniques chosen tend to make societies more egalitarian and distribute resources and power more fairly.

I'd love to hear some of your thoughts about what sort of criteria you would think about, and what tools and techniques you would use. I'll try to include them in the full book, in future updates of this booklet, and on the website, as appropriate.

Industrial collapse is a very big topic, and this booklet only covers a very tiny corner of it.

This particular booklet is about tools and techniques you can use cope with industrial collapse, or "gridcrash". In this booklet, I don't write about some of the other effects of that, like rioting or violence. So the knowledge in this booklet is quite handy in certain circumstances, and not so handy in others. If you live on the outskirts of a small town, for instance, this information will be quite useful. If you're living on a 15th floor apartment in downtown Los Angeles and the grocery stores are just about empty, power is out, and it looks like it won't come back on any time soon, this particular booklet won't be the most useful for you right away. (I would suggest that if you can, you quickly get to a place where it would be useful.) We'll get to those situations in further writings. In the meantime, I suggest that you (and everyone else) think about industrial collapse, what it means, and what you plan to do about it.

There are some basic tools that will be of use to people in somewhat settled communities. Most house dwellers would need tools to replace their faucets and taps (Water, page 1), their toilets and drains (Latrines and Greywater, page 15), their refrigerator and freezer (Cooling, page 22), their stove, oven, toaster and microwave (Cooking, page 27), their electric lights (Lighting, page 39) and their garbage and recycling pick-up (Rubbish, page 42). Furnaces and other house-related topics will be covered in more detail in future writings on the subject of shelter.

I hope that this information is useful to you. If you have any comments, or suggestions, or wish to contribute to the project, please do contact us. You can also check out the website at www.inthewake.org. There you can see more information about the book project, more discus-

sion and essays, more links to web pages and books of interest, as well as more information about relevant skills and strategies.

Thanks, and good skill.

Aric McBay
Occupied Detgahnyöhsráhdöh,
on the traditional lands of the Cayuga people
October, 2004

email: editorial@inthewake.org

Introduction Footnotes:

1. Mumford, Lewis. *The Myth of the Machine: Technics and Human Development*, Harcourt Brace Jovanovich, New York, 1966. Page 186.
2. Diamond, Stanley. *In Search of the Primitive: A Critique of Civilization*, Transaction Publishers, New Brunswick, 1993. Page 1.
3. Myers, R. A. et al. (2003) "Rapid worldwide depletion of predatory fish communities" *Nature* 423, 280-283, *Letters to Nature*
4. Gregg, W. W., and M. E. Conkright, (2002) "Decadal changes in global ocean chlorophyll" *Geophys. Res. Lett.*, 29(15), 1730
5. Atkinson, A. et al. (2004) "Long-term decline in krill stock and increase in salps within the Southern Ocean" *Nature* 432, 100-103, *Letters to Nature*
6. Thomas, C. D. et al. (2004) "Extinction risk from climate change" *Nature* 427, 145-148, *Letters to Nature*
7. UN-HABITAT, *The Challenge of Slums: Global Report on Human Settlements 2003*, UN-HABITAT, 2003
8. Duncan, Richard C., *Olduvai Cliff Revisited: The Olduvai Cliff Event: a. 2007*, March 5, 2001. (see online at http://www.mnforsustain.org/oil_duncan_r_olduvai_cliff_revisited.htm)

Acknowledgements

Thank you for the proofreading, comments and suggestions from MM, Tammy T., Melissa, Edward, Emily, Andrea, Pig Monkey, Wabbit, Lori, Ken McWatters, and several anonymous contributors. Thank you to Alex and Jen for the illustrations credited on pages 23 and 2 & 8, respectively. Thank you also to the many people who offered supportive comments and feedback.

In the making of this booklet I used free, open-source software including the text editor Vim, the word processor Open Office, the vector drawing application Inkscape, the raster image editing application GIMP, and the desktop publishing program Scribus.

Further Reading

Civilization and Industrialism:

Derrick Jensen's writings are some of the most insightful, intelligent, moving, and relevant works I have ever read. I heartily encourage you to read his work starting with *A Language Older than Words* and also his latest (not yet published) book, tentatively titled *Endgame: The Collapse of Civilization and the Rebirth of Community*. Derrick's website at www.derrickjensen.org includes a subscription "reading club" where you can read *Endgame* and other works currently in progress.

Anthropologist Stanley Diamond wrote the excellent book *In Search of the Primitive: A Critique of Civilization*.

Chellis Glendinning's *My Name is Chellis and I'm in Recovery from Western Civilization* is a moving and personal book in which Glendinning examines her own childhood abuse and traces its roots to civilization itself. It's an incredible examination of the insanity of the dominant culture, and the ways in which indigenous cultures are sane.

Lewis Mumford is an incredibly prolific writer, historian and social critic. Some of his most relevant books to these premises include the two-volume set *The Myth of the Machine: Technics and Human Development*, *The Pentagon of Power: The Myth of the Machine*, and *The City in History*.

John Zerzan is the author of a number of great anti-civilizational books, including *Running on Emptiness: The Pathology of Civilization*, and also edited the excellent book *Against Civilization: Readings and Reflections* which is available online at:

<http://www.blackandgreen.org/ac/index.html>

Daniel Quinn wrote the very readable stories *Ishmael*, *My Ishmael* and *The Story of B* about the origins of civilization. (www.ishmael.org)

Extensive related writings by a number of authors are available at:

<http://www.insurgentdesire.org.uk/>

<http://primitivism.com/>

Peak Oil:

Richard Heinberg's *The Party's Over: Oil, War, and The Fate of Industrial Societies* is an excellent introduction to

the topic of Peak Oil. He has also written a book about some of the options in response to the Peak Oil situation called *Powerdown: Options and Actions for a Post-Carbon World*. (www.museletter.com)

Matt Savinar's book *The Oil Age is Over* is also an excellent and readable introduction to the subject. There are also more articles and links at his website at www.lifeaftertheoilcrash.net.

Excellent websites on the subject of Peak Oil include www.wolfatthedoor.org.uk, www.dieoff.org, www.hubbertpeak.com, and www.oilcrash.com.

General Ecology and Overshoot:

Overshoot: The Ecological Basis of Revolutionary Change, by William R. Catton, Jr., is an excellent book on ecology and carrying capacity.

The website inthewake.org has more extensive listings and links on related subjects.

The next two excerpt booklets will be on the subjects of *Planning, Prediction and Preparation*, and *Shelter*. Visit the website for further information and up-to-date copies.

A note on references: The information in this book is a combination of the experience of myself and other contributors, and the print references listed. References that apply to a whole section are listed at the end of each section, and references which apply to a specific subsection are listed at the end of a subsection.

Water

Water is covered first here for a reason. People can die in as little as three days without water. How much do you need? In a shortage situation, try to get at least 15-20 litres per person per day. The “absolute survival minimum” according to the United Nations is 7 litres per person per day for wash and drinking water. People who are ill may need more. Some sources put minimal drinking water requirements as low as 2-3 litres per person per day for a healthy person in cool weather without strenuous physical exercise, but there may be significant health problems as a result of only drinking such small quantities. Wash water is needed to avoid serious health problems from infections and disease. If you are unable to meet that demand in potable (safe for drinking) water, you can use non-potable, brackish or salty water for some wash purposes. However, you should purify water used for washing the face or hands, or for brushing teeth.

Drinking alcohol, urine, blood, or salty water will increase your water requirements and should be avoided. Also, if you have extremely little to drink, consider minimizing your protein intake, as protein takes water to digest. If you have no water, you should not eat at all. On a limited supply of water, watch for signs of dehydration including: dark urine with a very strong odour; dark, sunken eyes; low urine output; fatigue; loss of skin elasticity; emotional instability; thirst; a “trench line” down center of the tongue; and delayed capillary refill in the fingernail beds. If you are in a survival situation without other sources of water, digging a well for water is not usually worth the energy and sweat.

Contamination

It doesn't matter how much water you have if the water is too contaminated to be drinkable. The contamination of water can be pathogenic, chemical, or physical.

Pathogenic organisms are “disease-causing organisms”, so pathogenic contamination refers to the presence of certain types of bacteria, amoebas, worms, or viruses. Giardia, or “beaver fever,” and cholera, are examples.

Chemical contamination includes contamination from

pesticides and industrial chemicals, or natural chemicals from rocks. DDT is a pesticide example, and salts and iron are examples of natural chemicals. (Of course, if you were a fish living in the ocean, you wouldn't consider salt a “contaminant,” so it is relative.)

Physical contaminants are not usually harmful, but can make the water unappealing to drink because of taste, colour or smell. “Cloudiness” (turbidity) is one example.

Avoiding contamination in the first place is always preferable to having to treat water. In almost every conceivable situation, it is easier to keep water clean than to clean it.

Sources of Water

There are three main water sources: groundwater, rain-water and surface water. We will also look at survival sources which don't quite fit into any one of those categories.

Groundwater, as the name implies, is present in the ground, below the surface. This includes water from wells and springs. As the water flows underneath the ground, it is filtered and purified by the soil. The United Nations considers groundwater the preferred source of water in refugee situations. A spring is considered the ideal source of groundwater, since you don't have to dig a well. Groundwater is generally free of pathogens, although contamination can occur from latrines which are too close.

Rainwater is also an excellent source of water, since it is generally free of contamination, although the supply varies widely according to climate. Assuming that the containers, evestrough and roof are clean, rainwater can be used safely without treatment. (See page 4)

Surface water can be a good source of water, but in most cases is contaminated from a variety of sources. Though surface water is easily accessible in many places, it generally requires some sort of treatment.

Survival sources of water are sources which are present

in small quantities, and often “embodied” in soil or plants. You might look at a lake and think “water”, but you can also get small quantities of water where it is not visible. These sources are not generally suitable for a large, concentrated population.

Groundwater

Wells

A well is simply a hole dug or drilled down to the level of the groundwater. Locating an appropriate site for a well can be a challenge, especially since hand-digging a well is *very labour intensive*, and you don't want to spend time and effort digging a dry well.

If there is a dry season where you are, try to dig the well at the end of it. That is the time when the groundwater level is the lowest. If you dig when the groundwater is high, it will move down in dryer weather, leaving your well dry. Look for indicators of a good site, such as healthy, green vegetation. Annual plants, such as ferns, are not good indicators, because they come and go with the seasons. Look for year-round plants which grow where water is close to the surface, like willow and cedar.

When siting a well, you want to try to find a place where the water table is as close as possible to the surface, so that your well will be easy to dig, but also where the water table is deep, so that seasonal variations will not dry your well. Refer to the image below, and to hydrological and topographical maps for your area.

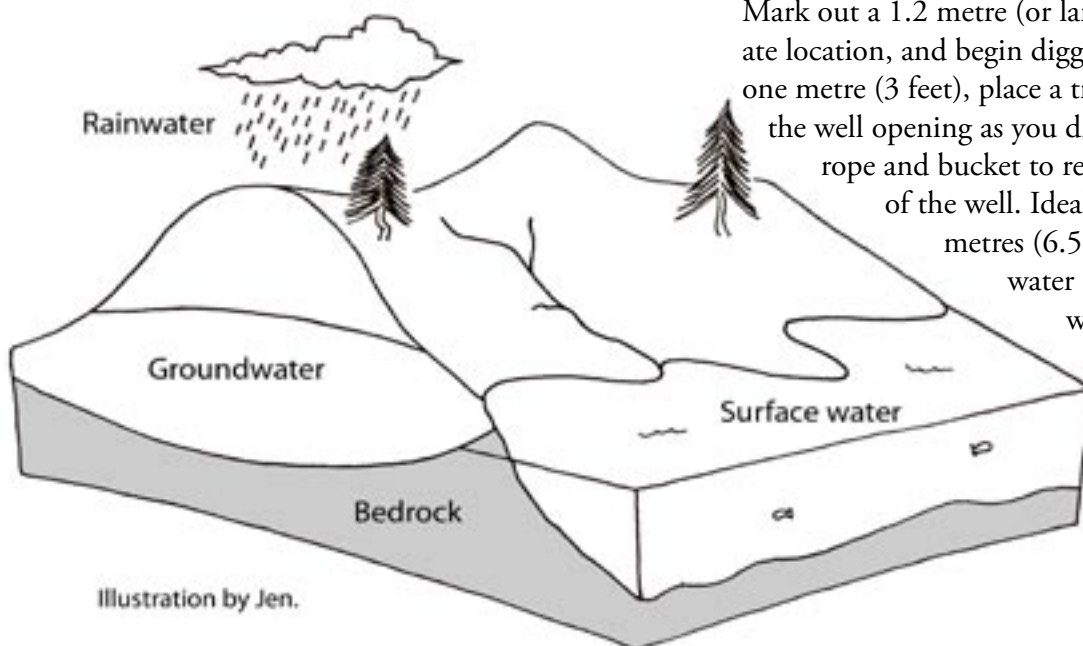

You can also place a well near a river (but at least 15 m away) which will be “recharged” by the river water. However, you should never place a well where it may be flooded by surface water, which could cause contamination.

Wells should never be dug near latrines, rubbish dumps or animal pens. Try to leave a distance of at least 30 metres (100 feet) from these possible sources of groundwater pollution. Wells should be at least 100 metres (330 feet) from possible sources of industrial pollution.

There are several techniques for well digging and drilling that are appropriate for an improvised situation. However, some methods require installing a pipe and hand-pump to operate, which is beyond the scope of this excerpt booklet. (For more information on simple drilling techniques, see WELL Technical Brief #43: Simple Drilling Methods, available online. You can also refer to D.V. Allen's *Low-Cost Hand Drilling*, Consallen Group Sales Ltd, 1993.)

The most appropriate method for an improvised situation is to simply dig a hole in the ground. A diameter of at least 1.2 metres (4 feet) is needed for two people digging together. UNEP suggests digging a well with a height to width ratio of 2:1. The well can have a deeper ratio if the soil around it is very cohesive, but if the soil is uncohesive it may need reinforcement. Dug wells have definite depth limitations, for safety and practical reasons, and so if your water table is very deep, they may not be appropriate. However, the deeper a well is, the better the quality.

Mark out a 1.2 metre (or larger) circle at the appropriate location, and begin digging. After you've dug about one metre (3 feet), place a tripod or anchored log over the well opening as you dig. This can be used with a rope and bucket to remove soil from the bottom of the well. Ideally, the well will be dug two metres (6.5 feet) below the top of the water table. Stop digging when the well has reached that depth, or when it's not safe to dig any deeper. If possible, use sections of culvert or concrete rings to reinforce the walls as you dig, to prevent collapse. These can slide down the walls as you dig deeper.

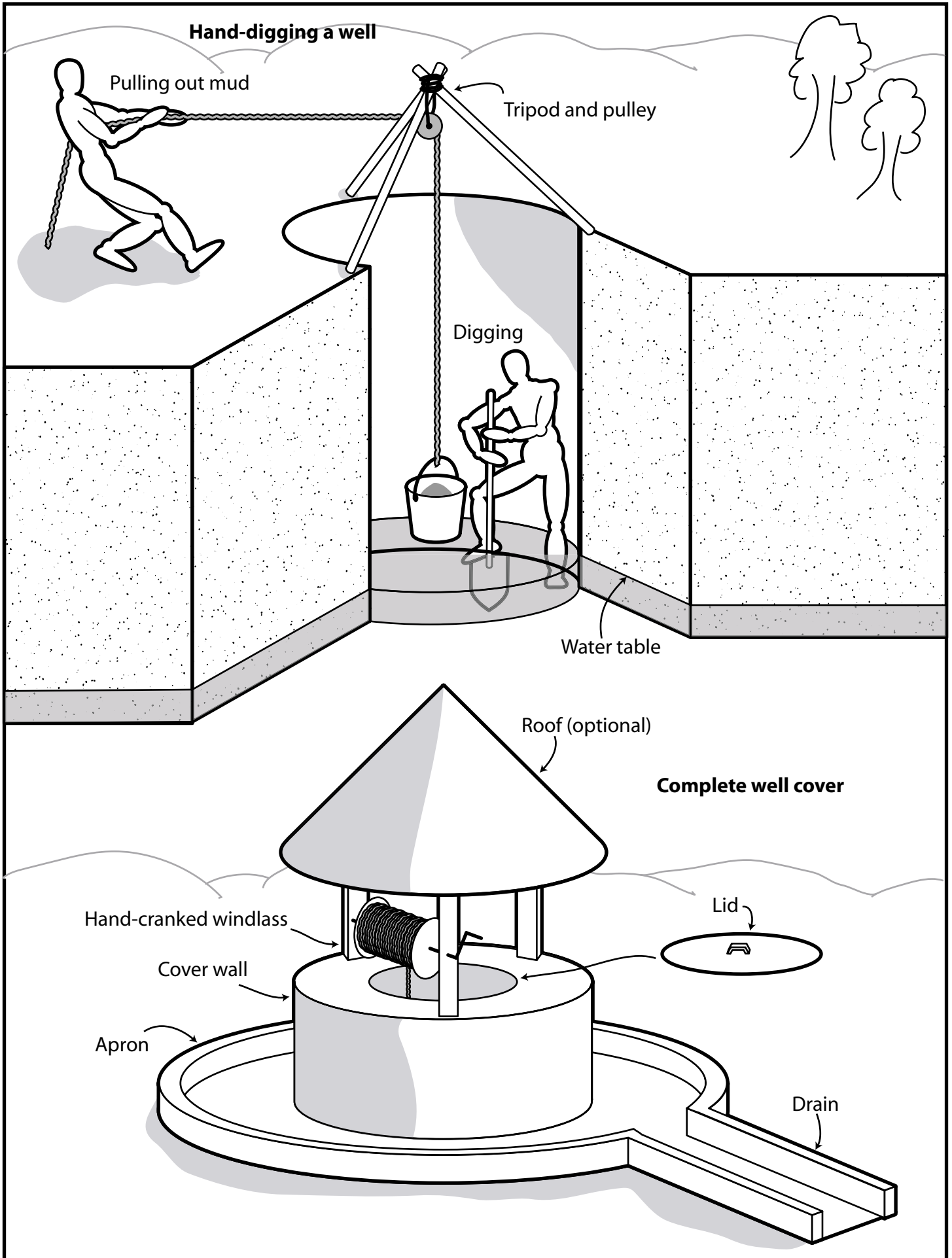

When finished, place a layer of gravel at the bottom of the well, if possible. It is generally suggested that you disinfect a well before using, or after possible contamination, with a chlorine solution (which you can make from bleach).

Wells can be improved for safety, sanitation, and longevity. Place a cover on the well so that people and debris cannot fall in. Always use a clean bucket to draw water from the well. If people physically enter the well, there is a danger of the well collapsing on them, or them causing contamination of the well.

If possible, line the walls of the well so that the walls do not cave in or shed soil into the water over time. You can use bricks and mortar, concrete rings, or whatever sturdy, non-toxic materials you have available.

You can also install a windlass or handpump, to make it easier to raise water.

To avoid puddles of water forming around the well, which cause mud and can breed mosquitoes, you can install a stone “apron” which will drain water away from the well.

Well notes:

Lifewater Canada, at http://www.lifewater.ca/Section_Tutorial.htm, has a 100 page manual on wells available online, as well as other information on water.

Waterhole: How to Dig your Own Well, by Bob Mellin covers drilling well with a hand-auger.

Wells and Septic Systems, by Max and Charlotte Alth

Springs

Springs are generally an excellent source of clean water. However, in some situations water from a contaminated surface source can travel a short distance in an underground channel and only *appear* to be a spring. You may want to check.

Springs appear in areas where the water table reaches the surface, generally on the side of a hill or other slope. The water is forced out to the surface. Check maps of your area for known spring sites. Also, spring-fed streams may be fuller in the dry-season than rain-fed streams. If you can identify spring-fed streams, you can follow them back to the source.

Development and Refugee agency handbooks generally

recommend “improving” springs to prevent contamination. This may or may not be suitable for your needs depending on the population density of your area, the nature of the pathogens present, and other factors.

This “improvement” usually means encasing the spring itself in a container (usually concrete) to prevent direct access by humans or other animals. The water comes from a spout which is installed on the container. This way, pathogens can’t be deposited into the spring itself, where they might breed. However, there are some less invasive methods described in WELL Technical Brief #34: “Protecting springs: an alternative to spring boxes” (see notes).

Rainwater and Snow Collection

Rainwater is a great source of clean water, so try to collect as much rainwater as possible. Allow the first runoff after a long dry spell to flow away, to clean dust and such from the roof or catchment. According to UNEP the ideal roofing for a water source is smooth, dense and non-toxic. They suggest that this includes “corrugated aluminium and galvanized iron, concrete, asphalt or fibreglass shingles, tiles with a neoprene-based coating, and mud”. They suggest avoiding the use of “natural” materials such as thatch as a source of drinking water, because such roofs may attract insects and rodents, and yield contaminated and discoloured water. They also suggest that flat ground surfaces, such as runways, can be used as long as they are fenced off to prevent access and contamination from human and non-human animals.

One millimetre of rainfall will yield about 0.8 litres of water per square metre of catchment area. (In US imperial units, that means that each inch of rain will give about 6.4 gallons per square yard.) Loss is due to evaporation, and varies by climate. In cooler climates you will get closer to a full litre per square metre (or 8 gallons per square yard).

Water storage containers should *always* be covered to prevent contamination. Also, pipes or openings to the tanks (except the faucet) should always be screened to prevent the access and breeding of mosquitoes or other insects. See the illustration for examples of several rainwater catchment options.

Rainwater catchment with barrels

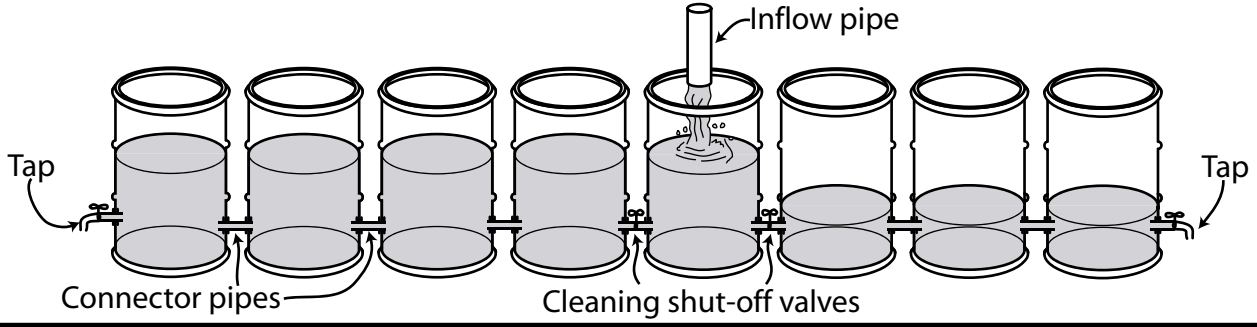
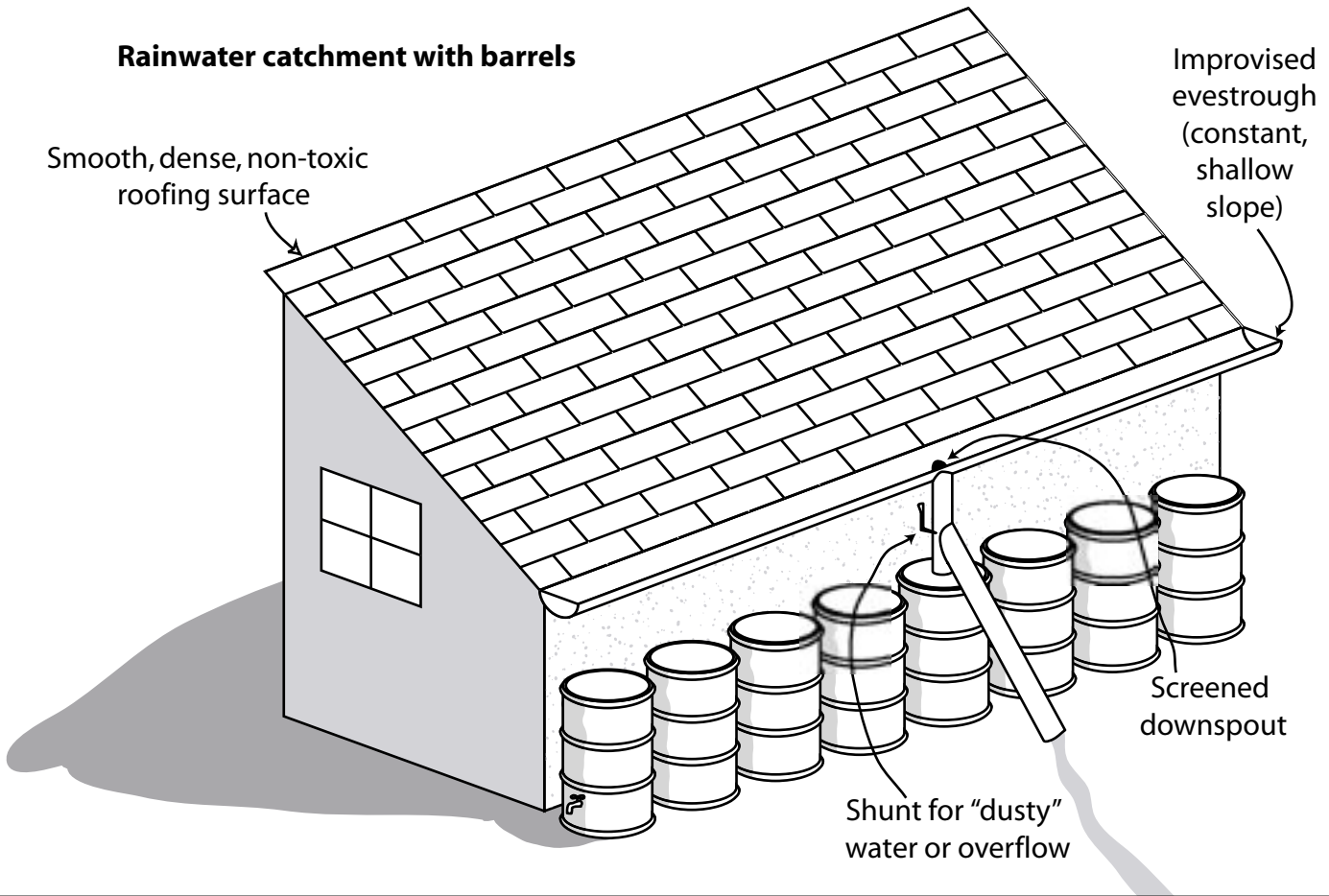

Single tank storage

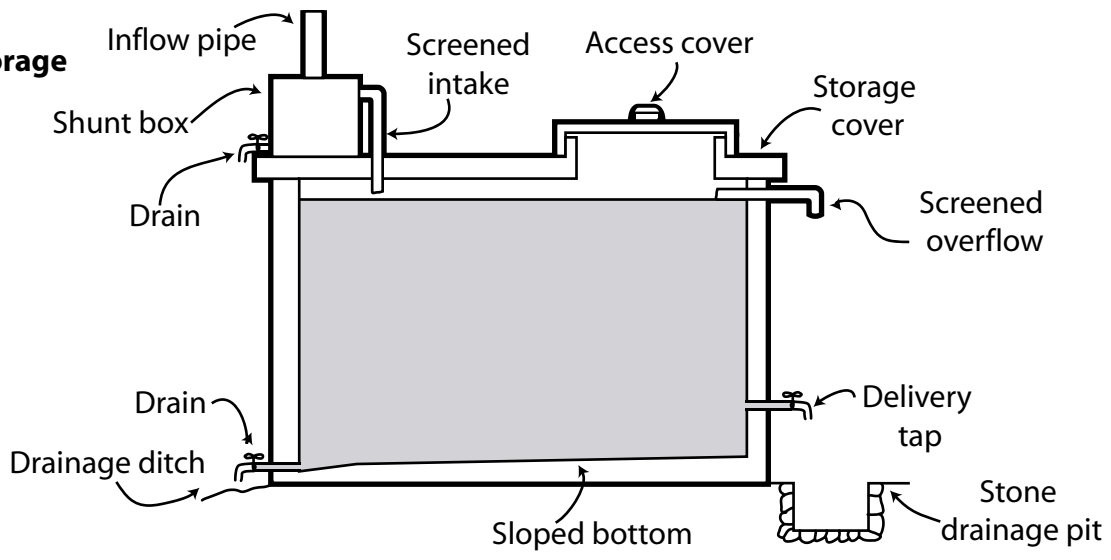

Single Tank Storage design based on a version from the *Sourcebook of Alternative Technologies for Freshwater Augmentation in Small Island Developing States*

Snow can also be used as a source of water, but should be gathered from clean sources away from animal traffic (including humans) to avoid possible contamination. Ten portions of snow will yield about one portion of water, so if you are melting snow in a container on a fire for drinking, keep topping up the container so that the water doesn't boil and evaporate. (Unless you believe the water is suspect and want to boil it.) Don't try to melt snow in your mouth. In cold climates, this will rob your body of too much valuable heat. If water is cold, just sip it, don't gulp.

Remember that snow is only as safe as the water it comes from, so treat it if you have any doubts.

Rainwater collection notes:

UNEP, Sourcebook of Alternative Technologies for Freshwater Augmentation in Small Island Developing States, <http://www.unep.or.jp/ietc/Publications/TechPublications/TechPub-8d/>

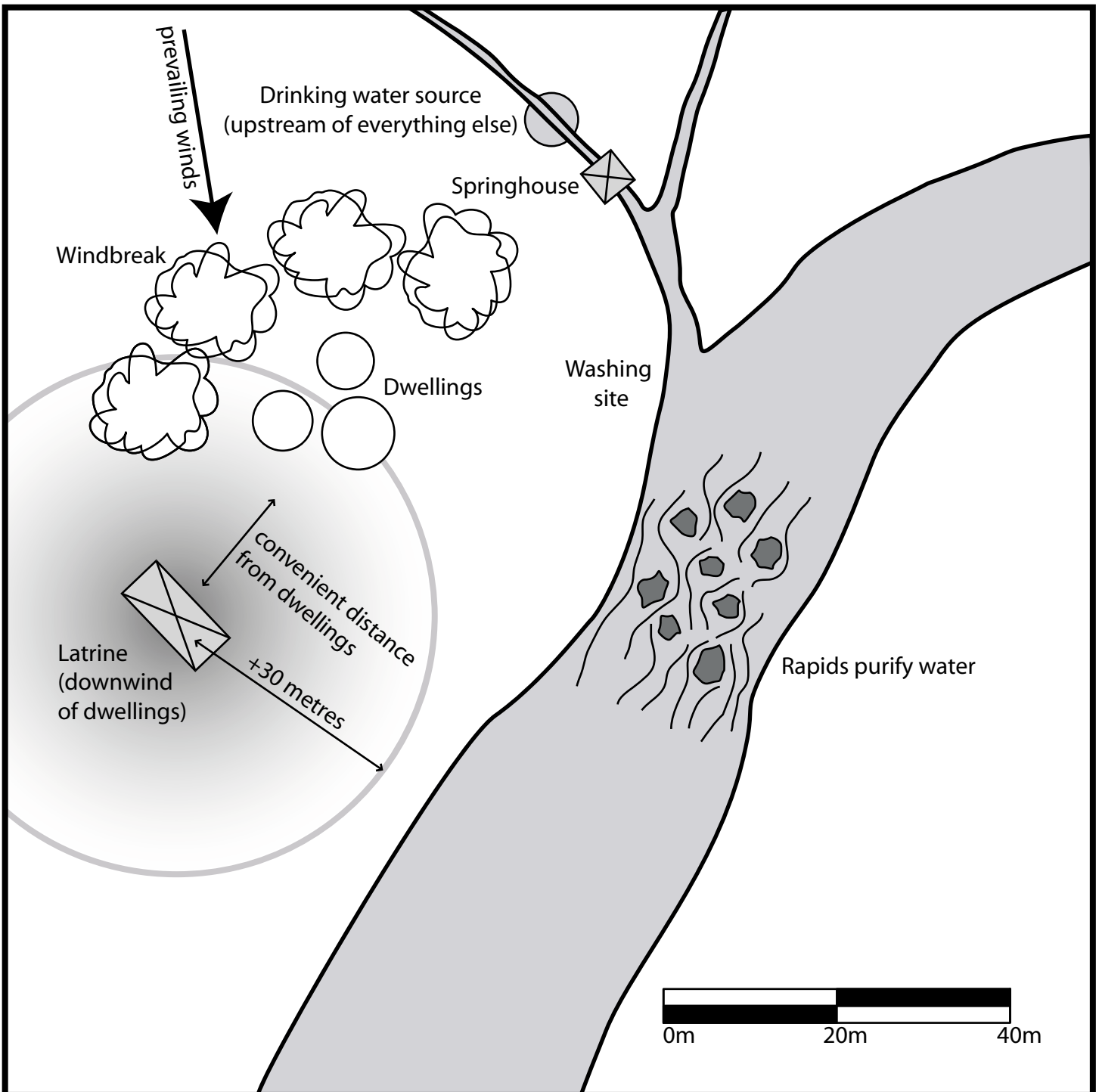

Surface Water Collection

When collecting water from surface sources, try to check for possible sources of contamination. Contamination can come from agricultural and industrial chemicals, soil erosion (especially in areas with industrial farming and logging), feces from humans and animals, garbage, from humans or other animals entering or washing in the water and tracking in contaminants or pathogens, or from dead animals in the water. Development and Refugee agency handbooks offer a variety of suggestions on how to prevent the contamination of surface water.

These include fencing ponds and rivers to keep farm animals out and discouraging people from entering or swimming in sources of drinking water. Generally, they recommend keeping swimming/washing and drinking water sources separate. To prevent the need to enter water, they suggest building ramps or platforms, into the water, which also reduces erosion in places where soil may run into the water.

Lively, bubbling streams or rivers with rapids and white water are great sources of drinkable water. The aeration purifies it in a distance of about 10 m.

Surface water notes:

WELL Technical Brief #47: Improving Pond Water

Survival Sources

Dug Still

One of the simplest ways to get water in a dry area is to dig a hole, as shown at above right, and place a container in the middle. Then place a clear plastic sheet over the hole, with a stone in the middle and weighting on the edges. The water that evaporates out of the soil will condense and drip into the container. You can also use a flexible hose to suck water out of the container. You might be able to add succulent leaves or vegetable matter into the hole, to provide more water for evaporation. Look for the best spot to dig a hole like this, such as depressions or valleys, areas with green plants, or areas which look damp. However, also try to place the still in a sunny spot, so that you get more evaporation and condensation.

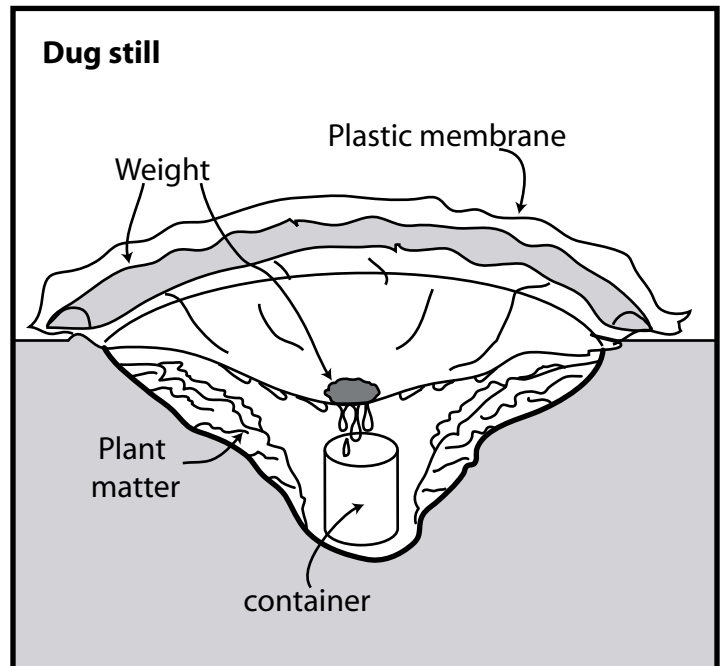

Transpiration

Trees and plants naturally release water through their leaves as they breathe. You can put a transparent bag, such as a clear garbage bag, over a branch as shown, below and seal it air tight. Water will condense and collect at the corner of the bag. You can make a small hole or slit to drain the water, and then tie or seal it shut again. Don't bag the branch for too long in hot weather, or it may die. **Do not use poisonous plants.**

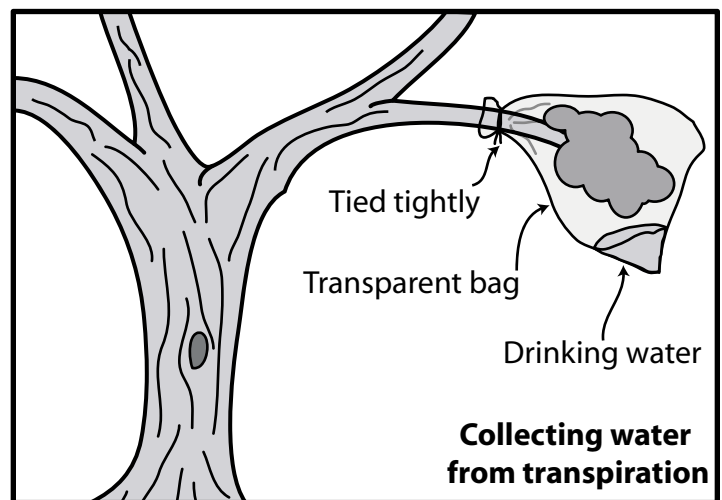

Dew and Condensation

In the early mornings or in cold, sheltered spots, you may be able to find dew on rocks, metal and vegetation. Use an absorbent cloth to sponge it up, and then wring it out into a container. You can tie cloth around your ankles and walk around in dew-covered grass before sunrise.

Water in Plants

Bamboo, banana and plantain trees, palms, and other plants contain water in their stems that you can access by cutting them. Consult local knowledge or books, and don't kill a tree unless you have to.

Observing other Animals

Watch animals like flies, mosquitoes, bees, doves and pigeons. They need to travel to sources of water regularly to survive, and you may be able to follow them.

Survival water notes:



Tom Brown's Field Guide to Wilderness Survival, Tom Brown Jr.

US Army Survival Manual: FM 21-76

Water Treatment

If you are in doubt, treat the water. You can die a lot faster or be sick for a lot longer from drinking a drop of contaminated water than you can from drinking no water at all. See the table below for a comparison of the effectiveness of different methods.

Effectiveness of different treatment methods:

 ineffective
  somewhat effective
  very effective

Method	Salts	Pathogens	Odour and taste problems	Turbidity
Straining				
Aeration				
Storage				
Boiling				
Chlorine				
Solar Disinfection				
Distillation				
Slow Sand Filter				
Rapid Sand Filter				

For a more detailed comparison, see WELL Technical Brief #48.

Simple Treatments

Straining

Straining turbid (cloudy) water through a clean handkerchief or other fine, cotton cloth is a good way of straining out larger particles of suspended contaminants like

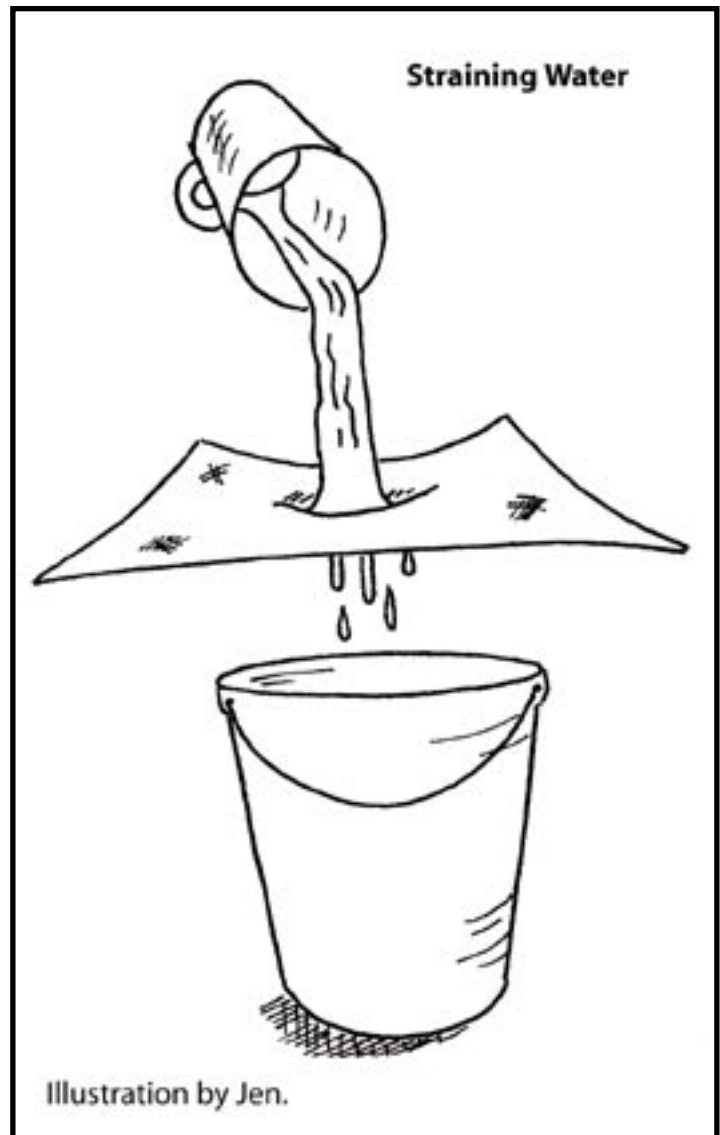

dirt. It can also remove certain tiny organisms (like copepods) that may carry pathogens, though such organisms are not present in all climates. Straining turbid water will improve the effectiveness of most other treatment methods, and is a good first step.

Aeration

Aeration adds air to water and reduces the concentration of "volatile" substances like hydrogen sulfide, which affect the taste and smell of water. It can also oxidize and immobilize elements like iron and manganese, which can cause taste and smell problems with water if present in excess. (They also stain clothes if the water is used for laundry.)

To aerate water, just shake a partly filled container of water vigorously, or pour it through a perforated tray containing small, clean pebbles.

Storage

Just storing untreated surface water will improve its quality. Particles settle out, and parasites that may be present will die, usually within a few days, without access to a host. Storing water for only 24 hours will kill about half of the bacteria in it. The improvement in quality will be greater at higher temperatures and over longer periods. If you are leaving turbid (cloudy) water to settle out, remember to take your water from the top layer, once the visible particles have settled.

Water containers should always be covered to prevent contamination.

WELL (see water notes) suggests using a three container system. The first container is used to put new water into, and the water may be strained as it is poured into this container. After one day, this water is poured into the second container, being careful to leave sediment or cloudy layers behind to be discarded. Using a tube to siphon water to the next container can help to leave the sediment undisturbed. The next day, water from the second container is poured into the third. The water in the third container has sat for at least two days, and is used for drinking water. WELL suggests occasionally rinsing this container with scalding water to sterilize it.

Glass containers are good for maintaining water quality, but are heavy and can break. You can look for food grade plastic containers for storing water. The preferred types of plastic for food are “Polyethylene Terephthalate” (PETE) or “High Density PolyEthylene” (HDPE). Look for the letters “PETE” or “HDPE” or the recycling numbers “1” or “2” stamped on the bottoms. However, keep in mind that some chemicals stored in the containers originally may leach into the drinking water stored inside. For example, the toxic aspartame in containers used in diet pop may leach into the drinking water, so such containers should be avoided if possible. **Never** reuse a plastic container that has stored toxic chemicals.

Disinfection

Disinfection kills the pathogens in the water. It is most effective if the water is relatively free of sediment and organic materials, so it should be the final stage in water treatment, after other contaminants have been removed.

Disinfection by Boiling

You can kill the pathogens in water by boiling it. At sea level, water simply brought to a boil is safe, but add one minute to the boiling time for every additional thousand metres (3300 feet) in altitude. (It’s something of a myth that water has to be boiled for five or ten minutes to be safe—this is just a waste of fuel. See Miller below, and other sources.) Be sure to strain out any larger particles by straining through a cloth, first. If it tastes “flat”, pour it back and forth between two containers a few times to aerate it. You can also add a chunk of charcoal from your fire, or some pine needles, during boiling, and remove them before drinking, to improve taste.

Boiling notes:

Miller, DeWolfe, ‘Boiling drinking-water: A critical look’, *Waterlines*, Vol.5, No.1, IT Publications, London, 1986.

Chemical Disinfection

Disinfection by adding chlorine (usually in the form of bleach) is also an option. However, it isn’t ideal, because the proper amount of chlorine to use can be difficult to determine, as well as because of the unpleasant taste and possible health side effects of ingesting chlorine. However, it is a *very* effective disinfectant.

The strength of chlorine compounds varies widely, and depends on storage conditions. Household bleach will rapidly lose its strength over time, though powdered chlorine (calcium hypochloride) will last longer, up to ten years under ideal storage. Use *only* pure bleach. Do not use bleach with fabric softener, or other laundry additives, because they are very likely poisonous.

To disinfect clear water with liquid bleach, first look at the concentration of chlorine you have in your bleach. For 1%, use 10 drops per litre, for 2-6% try 2 drops per litre, for 7-10% use 1 drop per litre, and let sit for at least 30 minutes. For slightly cloudy water, use at least double the number of drops. There should be a slight chlorine odour after. Otherwise, repeat the dose and wait another 15 minutes. Let it sit to reduce chlorine taste and smell.

Aerating chlorinated water after disinfection will also help the taste, as will adding a pinch of powdered vitamin C, which will neutralize the chlorine.

You can use household, medical iodine to purify water as well. For 2% USP strength, add 5 drops to clear water and 10 drops to cloudy water.

Chemical disinfection notes:

“Be Prepared with a 3-Day Emergency Food Supply,” by E. Schafer, C. Hans, E. Jones Beavers and D. Nelson, Iowa State University Cooperative Extension, November, 1997

Solar Disinfection

Solar disinfection works by a combination of exposing the water to the ultraviolet rays of the sun and raising the temperature, which kills microorganisms present. This technique is most effective in areas between approximately 35°N and 35°S, areas which receive large amounts of solar radiation each year. The American Southwest is an area in North America which also receives a lot of solar radiation.

In this method, containers of water are placed in direct sunlight, for a period of at least six hours. The water must be relatively clear, and shallow, to allow penetration of UV rays.

Glass containers can be used (but not window glass, which does not transmit UV radiation very well), but they are heavier, can break, and take longer to heat up. Plastic bottles made of PETE (polyethylene terephthalate) or PVC (polyvinyl chloride) are both good choices, but PETE is preferable, since it is not likely to leach harmful additives into the water. Bottles made of PVC often have a bluish tinge, and when burned, smells strong and unpleasant. PETE burns more easily, and has a sweetish smell.

Bags of water can also be used, and can be more effective since they can store water more shallowly.

Aerating the water by shaking it before placing it in the sun will significantly increase the effectiveness of this method of disinfection. When bottles become old and scratched, and start to become opaque, they should be replaced. Newer bottles will transmit UV light better.

The Swiss development agencies EAWAG and SANDEC recommend leaving the water out for at least six hours on sunny or partly cloudy days, or two consecutive days in cloudy weather. This primarily applies to very sunny regions, so solar disinfection is not a reliable method in less sunny regions.

Painting bottles black on one side (the side placed down) will help to heat the water up. If the water reaches a temperature of more than 50°C (122°F) for at least one

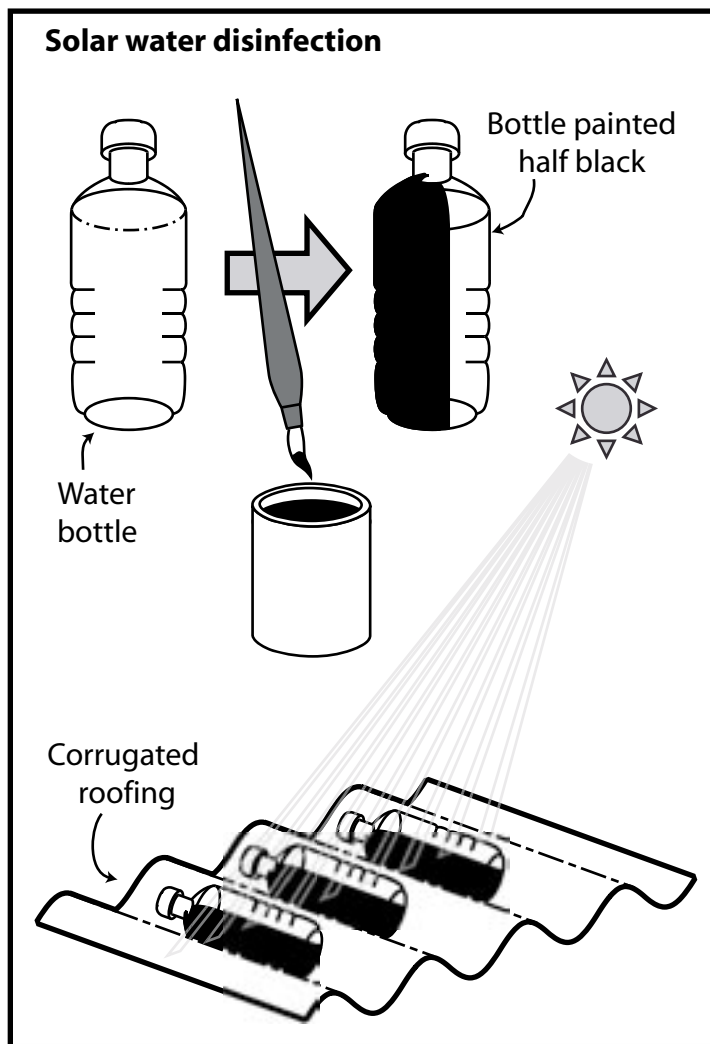

hour in the middle latitudes, it is safe. Placing the bottles on corrugated metal roofing will keep them in place and help to increase the temperature.

Using reflectors to concentrate sunlight on the water vessel will increase the effectiveness of this method by increasing the amount of UV radiation the water is exposed to, and increasing the temperature.

Solar disinfection notes:

Swiss development agencies have a large amount of information about solar disinfection at www.sodis.ch.

Distillation

Distillation works by evaporating water from a suspect source, which then condenses, leaving distilled water. This is an excellent way to get drinking water from seawater, and is the only method described here which will remove salt.

You can make a stove-top still, like the one shown, very easily. You place the still on top of a pot which is cook-

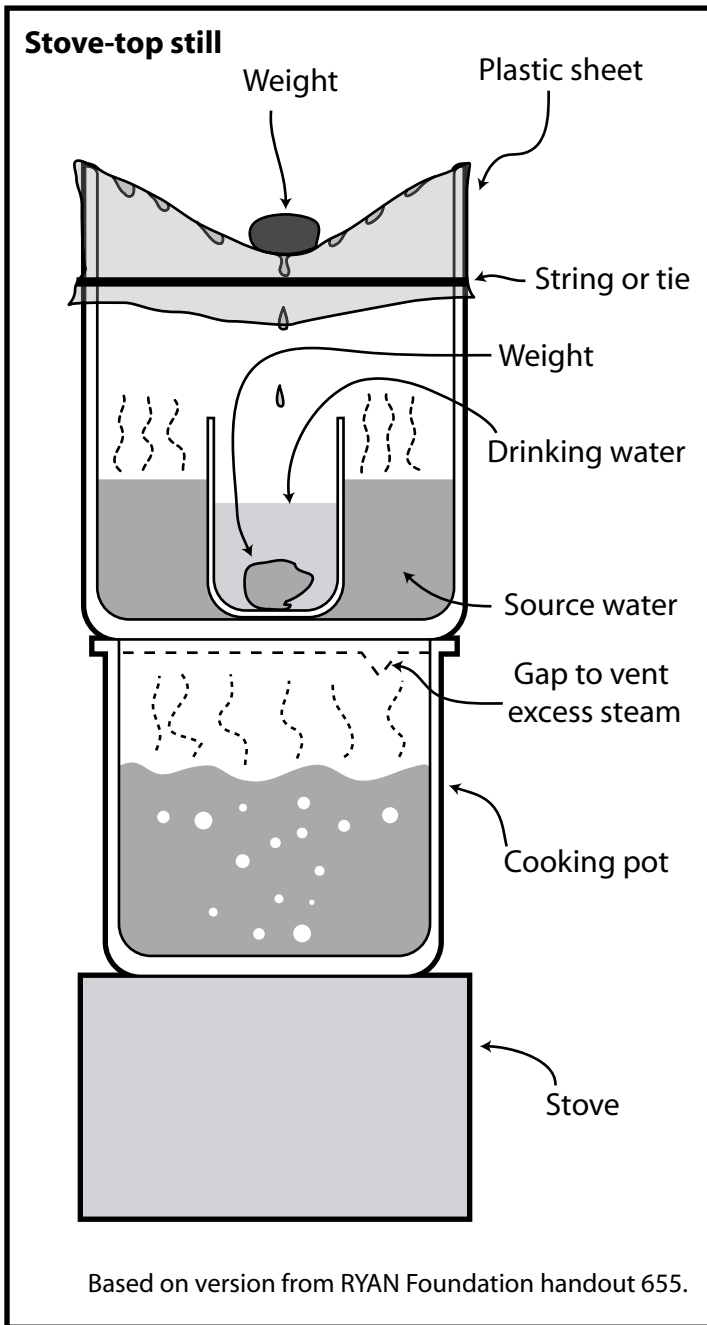

ing (assuming that you aren't using a fuel-saving haybox as discussed in "Cooking".)

Solar stills can be made easily and cheaply to provide a quick source of clean water. They provide enough water for personal use, but not enough for gardening, since they would have to be as large as the garden itself to provide enough water. They use solar radiation to evaporate water from a contaminated or questionable water source.

To make a solar still, make a small greenhouse out of the materials you have available. See the Cloche Style still for an example using windows or plastic. Make a container for the source water lined with black, so that the water

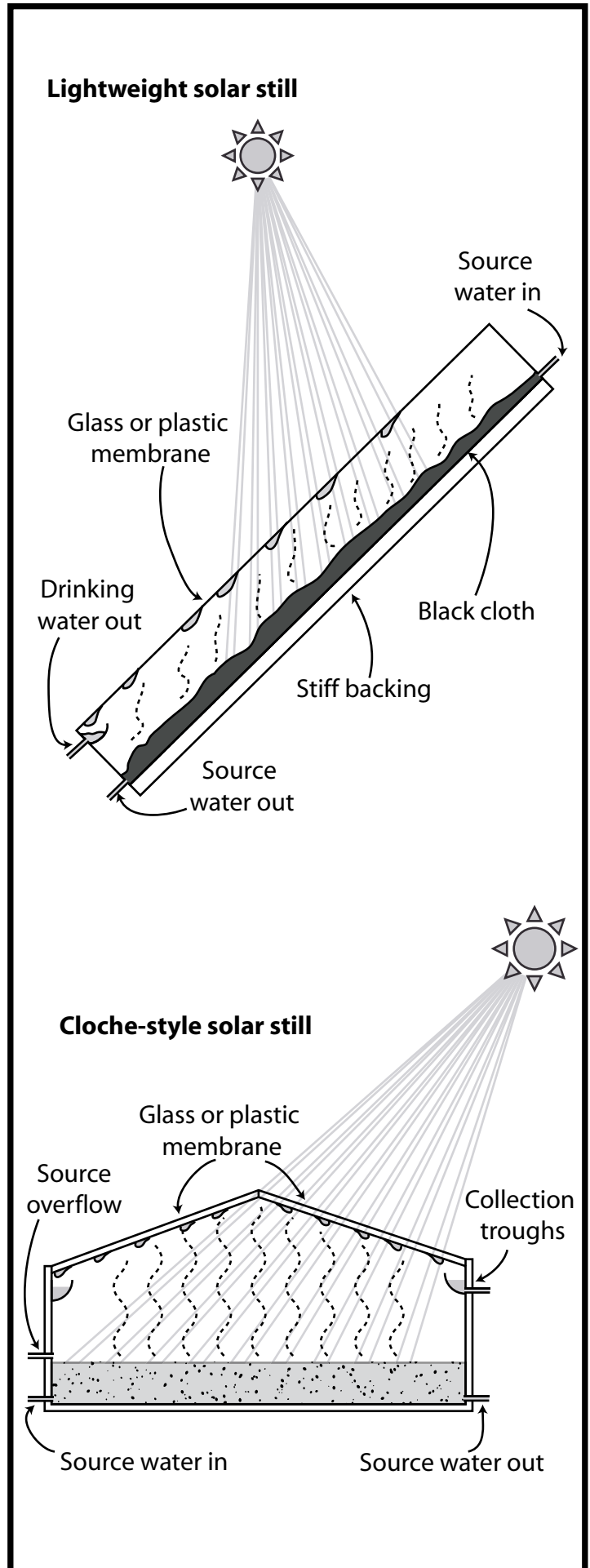

will heat up as much as possible in the sun. You may want to insulate underneath the source container if you are going to place the still on the ground. Then place a shallow trough along the lower edge to capture the condensed droplets as they slide down the glass.

Plastic sheeting can also be used, but some people report that droplets usually do not cling to plastic as well as glass, so they may drop back into the source container. However, the “clinginess” can be improved by lightly rubbing sandpaper over the interior surface of the plastic. If you do use plastic, make sure that it is pulled tight over the frame, or the wind may flap and tear it.

You can make a solar still with a sloped glass covering like the one shown below. This same device can be used as a solar food dehydrator, or a cold frame for gardening. (This is an example of how you can create equipment appropriate to your bioregion and climate: for example, if you have rainy springs, hot dry summers, and moderate autumns, you can use this device to start your vegetables in the spring, while you are drinking rainwater, and then

use it as a still to provide drinking water in the summer, and then to dry the produce in the fall.) You can make this kind of still (dehydrator, coldframe) from 3' by 6' patio door windows, which are regularly replaced at many apartment buildings. You may be able to buy them cheaply by the hundred. Admittedly, you might not be able to use them all yourself, but your neighbours will thank you when you share. (If you store glass in such numbers, be sure to store the panes with spacers so that they don't touch - water trapped between them will etch and mar the glass permanently.) For discussion on the glass's best angle see page 34.

You can also make a lightweight, portable version, like the one shown on the previous page. (Design from the excellent “Survival Scrapbook” volume three). This design would also work well on a rooftop.

A still can produce about 4 litres of water per square metre (1.26 litres per square yard), per day, on a good day.

The upside of the solar still is that you can put your wash water back into the still to get drinking water again. You could even put urine in.

For stills, keep in mind that the distilled water produced also has no trace minerals present, so it is not ideal as the sole drinking water source for young children over extended periods of time.

Exercise: Build a solar still for you and your family or housemates. Can you live off of the product for a week? How much of your water needs can you meet?

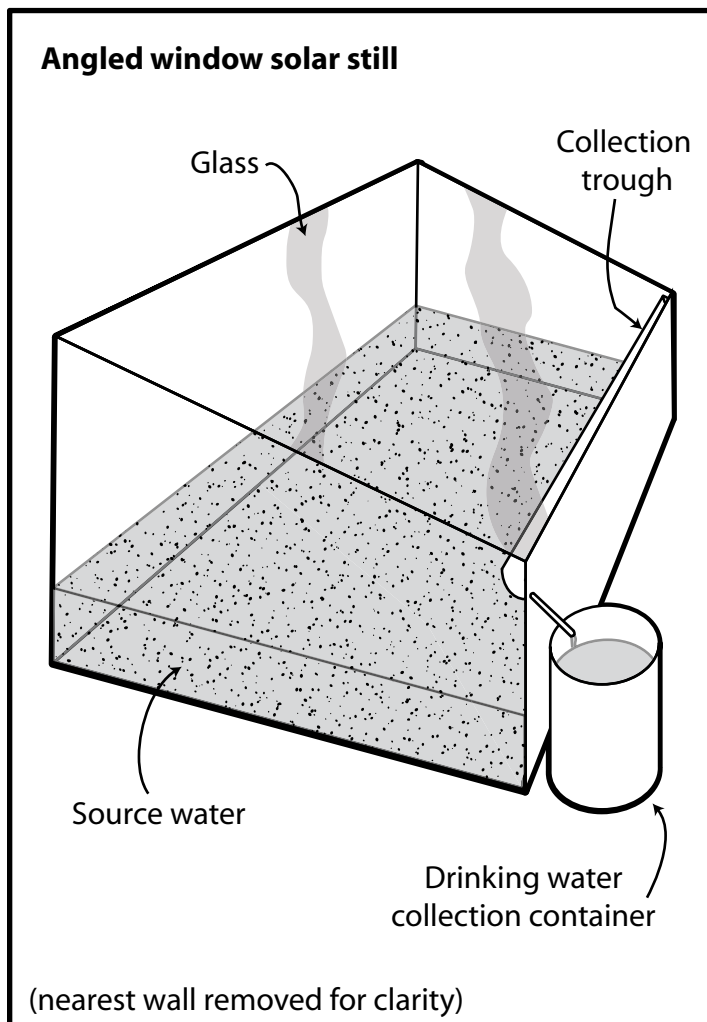

Sand Filters

Slow Sand Filters

In slow sand filtration, the source water flows slowly through a bed of fine sand. To work, the water must be relatively clear, and the flow relatively constant. The water flows through at a rate of about 10 to 20 centimetres per hour (4 to 8 inches per hour). The minimum acceptable depth of sand to function effectively is 65 centimetres (25.6 inches).

The slow sand filter works because of a biologically active microbial film that forms on the top layer of the sand, known as the “schmutzdecke”. The schmutzdecke

Rapid (roughing) sand filter

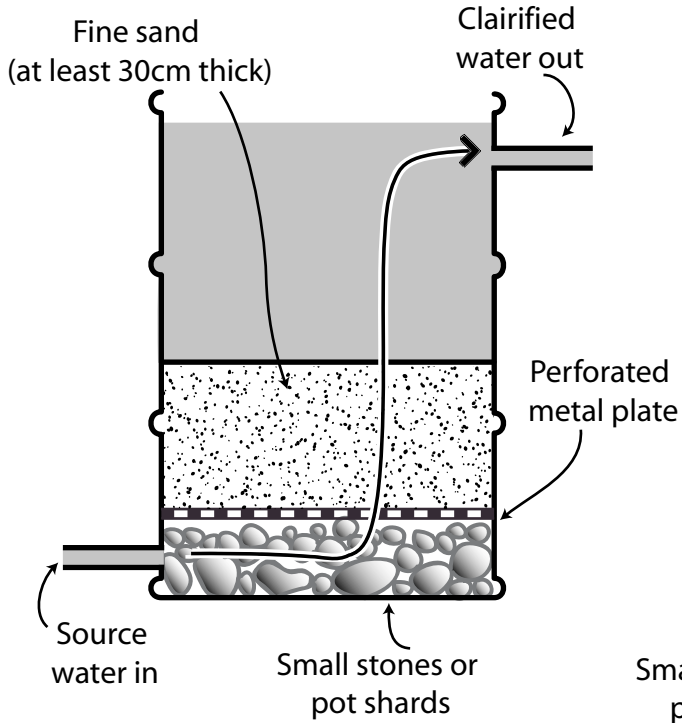

Slow sand filter

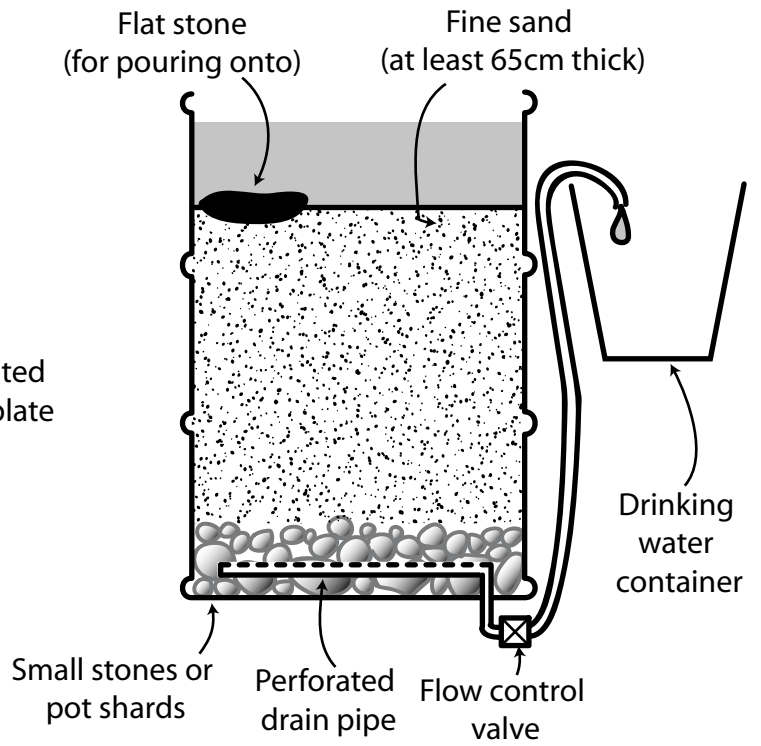

Gravity-fed water filtering system

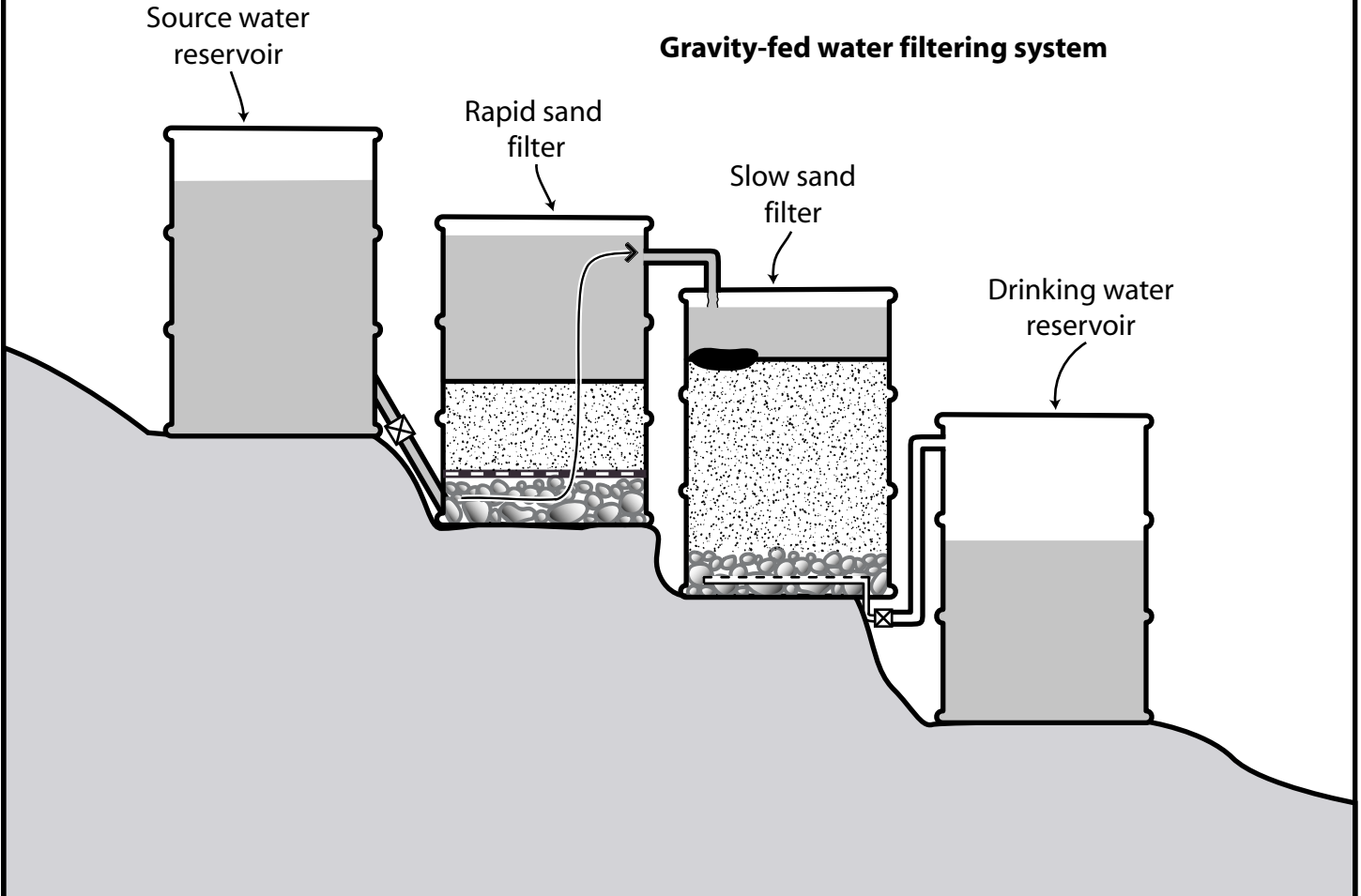

captures and “eats” organisms in the water. The schmutzdecke takes about one to two weeks to form, and so water coming from the filter before that should not be used for drinking.

To get a quantity of fine, uniform sand, you can try sifting it through a mosquito net or other fine screen.

The filter should be filled from the bottom up, to prevent the formation of air bubbles in the sand which would slow the flow of water.

Eventually the sand filter will need to be cleaned, because the schmutzdecke will thicken and slow the flow of water excessively. Fortunately, this thickening will not impair the safety of the filter. To clean, drain the water to slightly below the top of the sand, and scrape off the very top layer. Then fill up from the bottom. It will require another one or two weeks for the schmutzdecke to regrow.

Rapid Sand Filters

Rapid Sand Filters work to remove particles and turbidity in water, but do not form a schmutzdecke, and are not effective against pathogens.

One type of rapid sand filter that you can make is simply a barrel with a thick layer of sand on top of a perforated metal plate, on top of a layer of stones, similar to the slow sand filter. However, the water travels upward instead of downward, and can travel at a faster rate; about 0.5 to 1.5 metres per hour (20 inches to 60 inches per hour). The sand in this filter is at least 30 cm thick. The rapid sand filter needs to be “backwashed” (that is, flushed of sediment by letting the water flow in the opposite direction) regularly, perhaps as often as every day, depending on the turbidity of the water and the amount of spare water available for flushing.

Since slow sand filtration requires clear water, and rapid sand filtration provides clear water, you can put them in a gravity-fed sequence, as shown. Additionally, since the maintenance downtime for the slow sand filter is so long, you may wish to have several slow sand filters running simultaneously, so that you will always have at least one working.

Sand filter notes:

http://www.refugeecamp.org/learnmore/water/slow_sand_filter.htm

http://www.ce.vt.edu/program_areas/environmental/teach/

[wtprimer/slowsand/slowsand.html](http://www.wtprimer/slowsand/slowsand.html)

<http://www.esemag.com/0500/sand.html>

WELL Technical Brief #59: Household Water Treatment 2

General Water Notes

There are a few methods which I skipped over in this section, because they didn't fit into the requirements. Solar pasteurization is a treatment method which is distantly related to solar disinfection, but slightly more difficult. Essentially it involves elevating the temperature of water to more than 65°C (149°F) for more than six minutes, using sunlight (or other sources). The advantage is that it does not require UV radiation for disinfection and is more appropriate for non-equatorial latitudes. For more information, check out:

<http://solarcooking.org/docs.htm#Water%20Pasteurization>

There are also numerous commercial, small scale means of water treatment which aren't appropriate for improvised situations, which you can find out more information about for yourself. These include halozone tablets, and other chemical treatment methods, which you can get at pharmacies or camping / outfitting stores.

There are other general sources for learning more about drinking water below, which I used writing this section.

The IRC International Water and Sanitation Centre has an extensive online database of water-related publications: www.irc.nl/ircdoc/

UNHCR Water Manual for Refugee Situations

UNHCR Handbook for Emergencies

These and other UN refugee references are available online at:

www.the-ecentre.net/resources/e_library/index.cfm

WELL Technical briefs, available at: www.lboro.ac.uk/orgs/well/resources/technical-briefs/technical-briefs.htm

Water for the World Technical Notes

www.lifewater.org/wfw/wfwindex.htm has an extensive number of technical briefs on water and sanitation.

The Drinking Water Book, by Colin Ingram

Latrines and Greywater

Latrines

In the event of an infrastructure failure, dealing with feces—shit—is an important priority. Feces contain and potentially transmit a variety of pathogens, including bacteria, viruses, and worms. Exposed feces also attract flies, who may spread diseases. Latrines are structures that collect feces in one place, prevent access by insects, keep water from being contaminated, gives some privacy to the users, and in some cases, provide useable fertilizer.

Siting Latrines

Due to potential groundwater contamination, latrines should be a *bare minimum* of 30 metres (100 feet) from any well, body of water, or potential drinking water source (though this is less of a problem with most composting toilets). Medecins Sans Frontieres recommends a distance of at least 50 metres (164 feet) from water. They should also be a reasonable distance from dwellings—no less than about 5 metres (16.4 feet) (because of possible smell problems) or more than about 50 metres (for convenience). Latrines should also be downwind of dwellings, especially the improvised types.

Choose a site which is not going to flood. When digging a pit, leave at least 1.5 metres (5 feet) between the bottom of the pit and the top of the water table.

For hygiene purposes, there should be a source of soap and washwater near all latrines.

Pit Latrines

The simplest type of latrine is a pit, with some covering. In a wilderness setting, with few people, feces can simply be buried shallowly in the soil, at least 30 metres (100 feet) from water. This way the poop will be broken down by soil organisms easily.

In a setting with a denser population, a larger pit is required. Sizing the pit is important. The amount of poop that each person produces per day varies widely based on diet and other variables. A good general estimate is to assume that one person will give 0.04 m^3 (1.4 cubic feet) of solids per year. (The water content is less important, since it will drain out or evaporate). So for 25 people,

you will need a pit volume of at least 1 m^3 (35 cubic feet) per year of use. ($25 \times 0.04 \text{ m}^3 = 1.00 \text{ m}^3$)

Leave an additional 50 cm of depth from the surface in calculating the pit volume. You will need this space to put dirt back into, so make sure to set the dirt aside in a pile to put back in later.

Build a basic structure of some sort on top of the pit with the materials that you have available. One suggestion is shown in the illustration on the following page. It is important to have a close-fitting cover for the pit to reduce odours and keep out flies. Elevated seats are common in the culture I'm from. However, many people find it more comfortable to poop from a squatting position. There is some evidence that this is healthier for you, and it is certainly easier to make a simple hole in a board. However, this may be less appropriate for people who have difficulty standing up from a squatting position. If small children are afraid of falling into the hole, you can make a "hole cover" with a smaller hole in it, or simply make a second, appropriately-sized hole in the floor.

If the water table is too high, or the soil too shallow or tough to dig in, you can dig the pit in an elevated earth mound and/or use a barrel with a perforated or removed bottom and elevate the structure above it.

Depending on your soil type, and the shape and depth of the pit, you may need to line it with rocks or old drums (tops and bottoms cut off) to prevent it from collapsing. However, the lining should be porous at the bottom to allow liquids to leave the pit.

After use, when there is only 50 cm left between the surface and contents of the pit, move the structure on top to a new site, and fill the full pit in with the dirt.

If smells are a problem, users can put earth, wood ashes, or sawdust into the pit after each use. Wood ash (hardwood ash especially) is effective at limiting smell and fly problems.

Trench Latrines

Extend the basic pit latrine out into a line and you have a trench latrine. It's pretty self-explanatory.

Trenches can be dug in rows to increase density. Zig-zagging dividers can be put up for privacy. The trench latrine is generally considered an emergency measure, suitable for high population densities. Both it and the pit latrine should be upgraded as soon as possible to a more hygienic system, such as the Ventilated Improved latrine (VIP).

Ventilated Improved Pit Latrines

The VIP latrine is an enhancement of the basic pit latrine which addresses smell and fly problems. A ventilation pipe is added (as shown) which extends at least 50 centimetres (20 inches) above the top of the shelter roof. As air moves across the top of the pipe, it draws air up out of the shelter and pit. A mosquito net on top of the

pipe traps flies inside, where they die. The interior of the shelter should be relatively dim, so that flies are attracted to the light from the pipe. This latrine does not include a lid for the hole, since air is constantly drawn through, keeping smells to a minimum, but you may need to use one anyway in less windy areas.

Other Options

Additional options, such as the pour-flush latrine, exist. The pour-flush latrine has a U-shaped water seal (the same concept as you might find underneath many indoor sinks) which reduces smells and flies. The liquid effluent drains into a leaching pit. For more information on this and other options, check out the latrine notes.

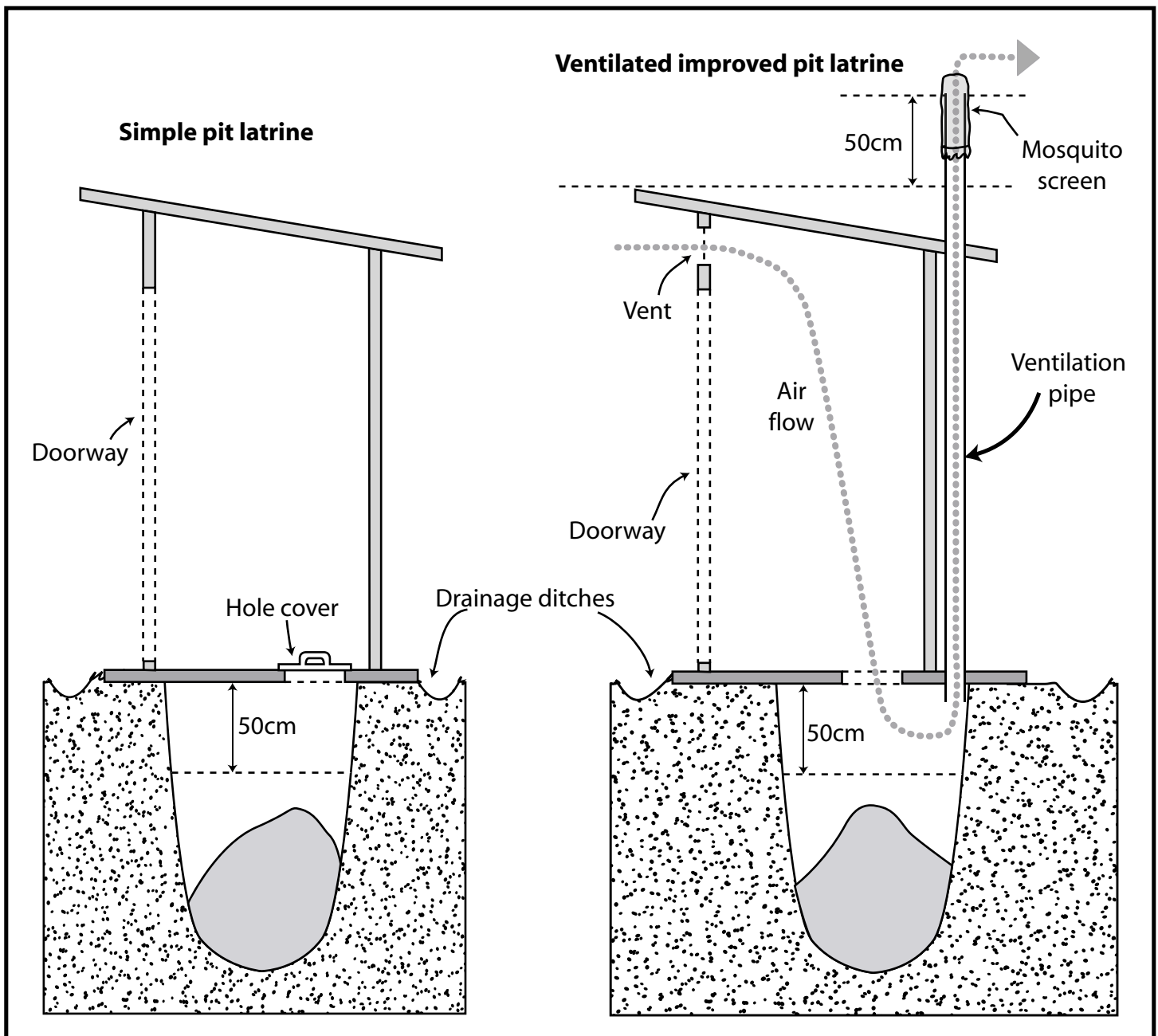

The pit/trench and VIP latrines can be constructed quickly and easily. They are relatively safe, provided that they are not close to a food or water source. Sanitation is aided by the fact that no one has to handle the feces and urine, the hole is simply refilled.

However, they are likely to introduce pathogens into the groundwater, even if the pathogens are only near to the latrines. The breakdown of the feces is mostly an anaerobic (without air) process that produces a variety of unpleasant gases such as methane and hydrogen sulfide (which smells like rotten eggs). And the nutrients in the feces and urine are lost in the pit, which means that gardeners must find alternate sources of valuable nutrients like nitrogen. On a farm about 80% of the nitrogen comes from animals. Soils have already been mined of nutrients, and they need the nutrients in our poop. Besides, for many people during collapse, the only source of animal manure for gardening will be their own.

The main alternative to the pit toilet is the composting toilet.

General Latrine Notes

World Health Organization briefs:

www.who.int/docstore/water_sanitation_health/onsitesan/ch04.htm
www.who.int/water_sanitation_health/hygiene/om/en/linkingchap8.pdf

WELL Technical briefs, available at:

www.lboro.ac.uk/orgs/well/resources/technical-briefs/technical-briefs.htm

UNHCR Handbook for Emergencies

UNHCR Water Manual for Refugee Situations

Composting Toilets

Composting is an aerobic process—it takes place with the presence of air. That means that properly operating composting toilets do not produce unpleasant smells or gases. The temperatures reached inside the compost, along with the time the compost spends “curing”, kill the disease organisms that might be present. Composting toilets also conserve the nutrients in the feces and urine, so that they can be returned to the land. Compost itself contains valuable organic matter that does wonders for soil life and gardens, a topic which will be expanded on in future writings on gardening.

Some people are worried about the fact that one might

have to handle material containing human feces. This is a valid concern, but it shouldn't be a problem if proper handwashing and other simple precautions take place. After all, most of us are quite literally full of poop all the time, and use the toilet on a regular basis, and it doesn't harm us. As long as you wash properly, a composting toilet is no more dangerous than any other kind of toilet.

For extensive information on the subject of composting toilets, please read the well-written and thoroughly researched *Humanure Handbook*, by Joseph Jenkins. You can visit his website at www.jenkinspublishing.com/humanure.html, where the entire text is available online. He uses the term “humanure” to refer to human poop.

Composting is a process in which microorganisms, normally present in the soil and all around us, break down organic materials like kitchen scraps, straw, poop, and so on. Essentially, they eat it. As they do this, they also generate heat, the same way that our bodies generate heat all the time. This heat builds up in the pile, and the increased temperatures kill pathogens present. There is a special class of microorganisms called “thermophilic microorganisms.” These microbes love high temperatures. If you can get the pile up to thermophilic temperatures, above 45°C (113°F), these microbes will love it. The composting process will happen very rapidly, and all pathogens will quickly be killed.

A well made compost will not smell, and will be quite warm. The essential ingredients of a good compost are **sufficient moisture, oxygen, a warm enough temperature, and a good balance between carbon and nitrogen.**

The compost should *not be too dry, or too wet*. If it is too dry, the microorganisms will not be able to grow properly, and valuable nitrogen will be lost to the air. If it is too wet, than the air won't be able to get in, and the compost will become anaerobic (and smelly). A compost should be about as damp as a wrung-out sponge. If your compost is too dry, just add household wastewater. If it is too wet, you need to add more bulky material like straw, or other roughage materials discussed below.

Giving a compost pile *oxygen* means giving it air. This is why bulky materials are so important. You can use sawdust, leaf mould, peat moss, weeds, hay, straw, leaves, rice hulls, shredded paper or cardboard, or similar materials. If something in the compost pile smells bad, cover

it with this bulky material.

Temperature is important because the thermophilic composting microbes need a certain minimum temperature to operate, and because the elevated temperature kills pathogens (just as a fever kills pathogens in our bodies). In cold climates, they will sleep over winter, but the compost pile will come alive again in the spring. This freezing also kills some pathogens. You can continue to add compost to the pile even if it is frozen.

A good *carbon to nitrogen* ratio helps the compost to heat up, by giving the microbes a healthy, balanced diet. The bulky materials listed above are very high in carbon. Adding manure and urine equalize the nitrogen ratio. You want to have a ratio of carbon to nitrogen somewhere between 20:1 and 35:1. If you have too much nitrogen in your compost, it will release that nitrogen as ammonia gas, which you don't want. Not only will you lose nitrogen, but it smells bad.

Many people do not pee in their composting toilets, because it causes a smell for them. This smell comes from excess nitrogen and water, and adding roughage compensates. Jenkins recommends including urine in a well-balanced compost, but most of the people I know simply apply their urine (diluted with 3 to 6 parts of water) to their garden or orchard. (Urine is almost universally free of pathogens. Only urinary schistosomiasis can be spread by urine, and it exists only in a few tropical locations.) See what works for you with your climate and soils. If putting urine in your composting toilet isn't working, your nose will tell you quickly.

Separating urine may also be a good idea in situations where the nitrogen content is required immediately for gardening, and the gardener can not wait several years for the compost to cure.

See the books in the notes at the end of this section for comprehensive tables of the carbon and nitrogen contents of different foods and organic materials.

There is a wide variety of home made and commercial compost toilets, but, of course, we will discuss those you can make yourself.

The two discussed here are the two-chamber mouldering toilet, and the Jenkins sawdust toilet.

The Jenkins Sawdust Toilet

Described by Joseph Jenkins in the *Humanure Handbook*, the sawdust toilet is a convenient method of composting your humanure while still having a toilet inside your home. This method consists of two parts, a **toilet receptacle** inside, which is filled with sawdust or other roughage, and regularly emptied into a set of **composting bins** outside.

The toilet receptacle inside is simple to construct, and can be made in a variety of different ways. Using 5-gallon buckets as the receptacle is easy, since they are so common. Jenkins recommends not using a larger size than that, since the contents would be very heavy to carry out to the pile. You can build a toilet seat on top of it, or a platform to squat on.

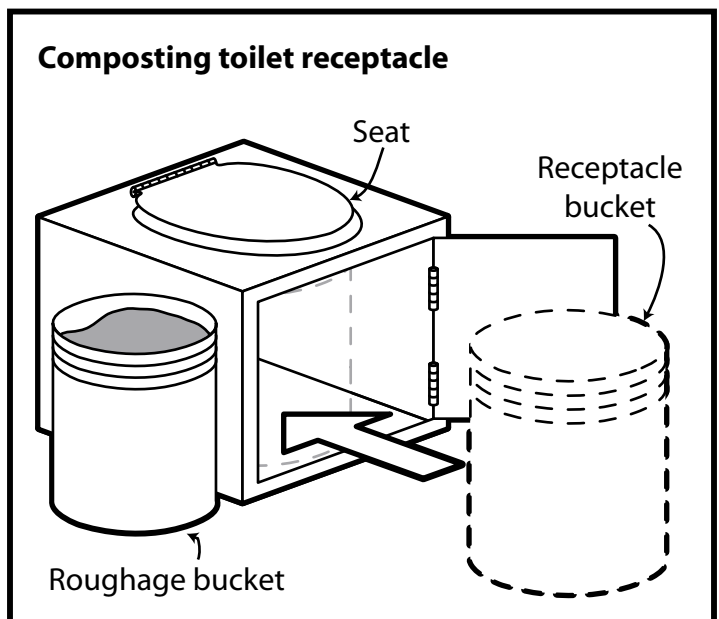

After each "deposit", add roughage to cover the feces and urine. This toilet does not require an airtight or fly-proof lid, since the roughage keeps out flies and cuts smells.

When the receptacle is full (or almost too heavy to carry) it can be dumped in the compost bin and buried in the top layer of the compost pile.

There are a number of designs for the compost bins, many of which vary by climate. People in hot, dry climates, may need to dig a pit to put their compost in to conserve valuable moisture. People in very rainy climates may need to build a roof over their compost pile to keep it dry enough, and prevent nutrients from leaching away.

Jenkins suggests a simple rotating multi-bin system, as shown. Remember that you will need at least two bins, one for this year's compost pile (still being built), and one for last year's which is composting. If climate or other constraints prevent your compost pile from reaching thermophilic temperatures, you will want to add a third bin to let the compost mature for a full two years. You may also want an extra, sheltered bin to keep roughage such as straw, grass, or hay in.

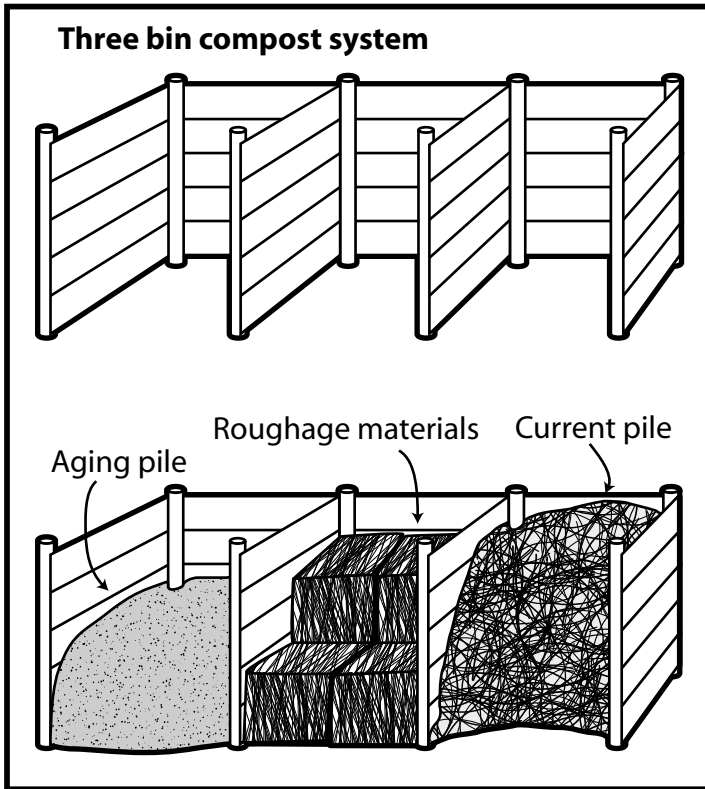

When starting a new humanure compost pile, put down at least 18 inches of roughage. This “sponge” will soak up any fluid leaching from the pile to prevent contamination.

If you don't have any smells, hopefully you won't have any trouble with animals digging into the pile. If this is a problem, you should put wire or other barriers around the pile, to prevent animals from accessing the pile and spreading pathogens.

The Two Chamber Toilet

This composting toilet is essentially an outhouse version of the general system described above. The “bathroom” is located directly above the composting chamber, as shown. There are two seats (or holes, if you prefer to squat), one for each chamber. The chambers are used one at a time. While one chamber is composting and closed

off, the other is in use. After each deposit, roughage is dropped into the chamber.

You can make the chamber out of cement, wood, or other materials that you have available. However, it need not be air or fluid-tight. You will need a door on the “back” to access the compost for checking on it and eventually emptying the chamber. You may need to smooth the pile, check the moisture, and add more roughage.

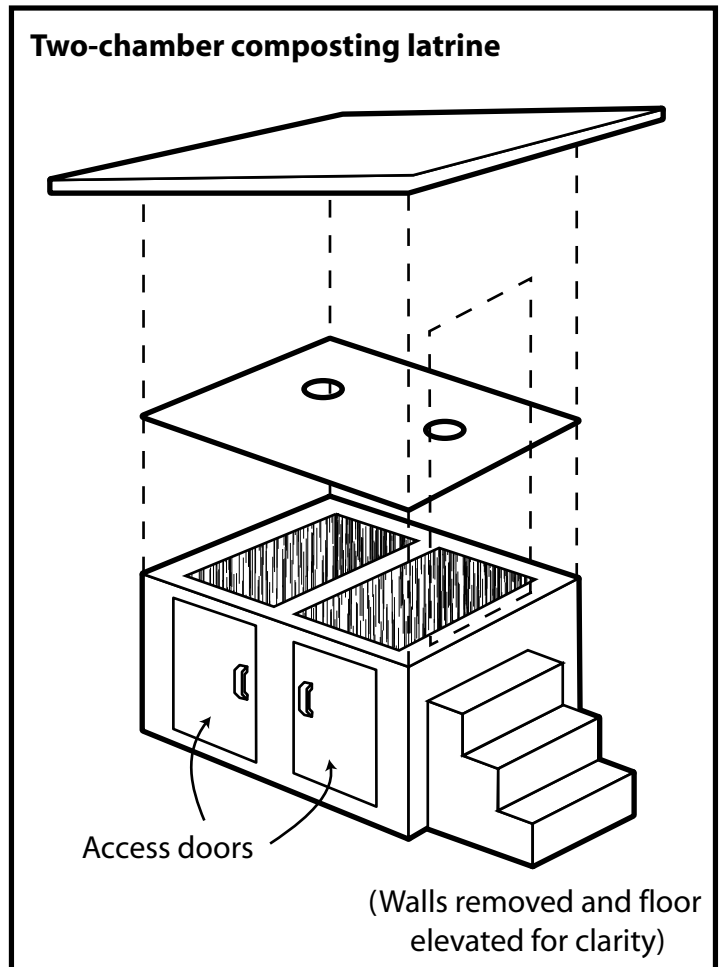

Variations

There are plenty of variations on simple and homebuilt composting toilet designs. To increase the composting temperature, some toilets use solar energy to heat the pile and accelerate decomposition. You can enhance the two-chamber design above by facing the chambers towards the south and placing glass or translucent plastic on the wall to let in sunlight. You could even include reflectors to heat things up even more.

Some designs also include perforated pipes or other means of increasing the air supply to the compost pile.

Others creatively incorporate reused barrels or other materials in their toilets. You can check out a variety of designs on the web, and experiment for yourself.

Composting Toilet Notes

www.compostingtoilet.org/

The Humanure Handbook, by Joseph Jenkins

The Toilet Papers, by Sim Van Der Ryn

More information on composting in general will be covered in future writings. In the meantime, check out excellent books on the subject like “The Real Dirt: The Complete Guide to Backyard, Balcony, and Apartment Composting” by Mark Cullen and Lorraine Johnson.

Greywater

Greywater is the water from sinks, washing dishes, showering, and so on. It does not contain nearly as many nutrients as humanure or urine, but *it can contain some pathogens*. Greywater should be treated with reasonable caution. It can also contain food scraps which might attract rodents and other animals, or produce smells. To avoid these problems, it's good to get the water under the soil as fast as possible.

Because it can contain pathogens, *it should not be applied directly to vegetables* which will be eaten. However, it can be applied to trees or berry bushes, which is an excellent way of reusing the nutrients and water. Greywater should not be poured into streams or bodies of water. *Greywater pits should be built a safe distance from water sources* like streams and wells, at least 30 m depending on soil conditions.

Depending on how much greywater you produce, you can pour at least part of it into the top of your compost pile, assuming that this won't make the compost too wet. That is one of the best ways to deal with it.

In cold climates, you may have trouble with greywater freezing in the winter, or snow covering the greywater pit. If possible, put the pit behind a windbreak (so that the prevailing winds will not drift snow over top of it) and pour the water in. The heat from washwater, and the heat of the soil should help except in extremely cold areas, in which case you will simply have to wait for the water to thaw in spring. The branching system described below is not ideal for very cold climates in winter.

Greywater Pit

The simplest way to get rid of greywater, and one very appropriate for camping or wilderness situations, is to dig a pit about 1 foot wide by 2 feet deep. You can put criss-crossed sticks and long grasses over the top to act as a grease trap, which will filter out some grease and food scraps. You can then regularly burn the grasses in your fire.

You can build a larger pit as well, such as one made out of a drum with large holes punched in it, or the bottom cut out. The barrel can be partly filled with stones and gravel, which prevent access by rodents.

The downside of the simple pit system is that the one area receives a lot of water and nutrients, maybe too much, while other areas aren't getting enough. You can improvise a branching greywater system to distribute greywater to a larger area, such as an orchard.

Branching System

This system works using a downhill grade. Water is channelled from the house, washing site or dump site, to mulch covered troughs.

The channels may be simple improvised, shallow trenches in the surface, depending on conditions. Better yet, they may be covered, filled in with gravel and small stones, or replaced by pipes. These channels must slope downhill continuously, or the water will back up or pool.

The destinations are shallow depressions or trenches full of mulch. The water may go directly into the mulch, or into a gravel filled container, which then releases the water into the mulch. Alternately, water could be poured directly into the gravel bucket, as an improved pit system.

Greywater Notes

Create an Oasis with Greywater: Your Complete Guide to Managing Greywater in the Landscape, by Art Ludwig. You can visit the author's site at www.oasisdesign.net

The Humanure Handbook, by Joseph Jenkins

Fieldbook for Canadian Scouting, Boy Scouts of Canada, 1986

A Note on Heat

Whenever we talk about cooking and cooling, we are talking about the movement of heat. We are talking about the devices we make gaining, losing, and storing heat. Heat storage is the same as thermal mass. A massive, heavy object, like a steel anvil, a barrel of water, or a brick wall, can absorb and store a lot of heat. It takes a lot of heat gain to heat them up, and a lot of heat loss to cool them down. In contrast, air has very little thermal mass, and heats or cools easily. (This is also why being in air at 100°C is merely uncomfortable, while being in water at 100°C is lethal. There is a lot more heat stored in each litre of water than in air, and the water conducts that heat into your body more easily.)

Heat moves through convection, conduction, and radiation.

•**Convection** is the movement of heat by circulation in a fluid (a gas or liquid). Air over a heater warms and rises, which draws in cool air from nearby, which also warms and rises. As the air gradually gives its heat to the ceiling, it sinks down to start again. Many people think that heat rises, but heat itself will go in any direction; it is warm fluids, like air, which tend to rise. The heat within those fluids is then released into the cooler things that they touch.

•**Conduction** is the direct movement of heat through an object. When you stick a metal rod into the fire, heat moves along it by conduction, and gradually heats up the other end.

•**Radiation** is the movement of heat directly from a warm body outward, like the light from the sun, or the heat from a fire.

This is important because we want to alter the movement of heat in our devices. When you want to stop the movement of heat away from the food you are cooking to conserve fuel, or the movement of heat into food you want to keep cool, consider how heat moves and how you can slow its movement. To slow heat loss by convection, minimize or eliminate air pockets or gaps in which air can circulate. (Air will not circulate in gaps less than about 1 cm or 3/8" across.) To slow heat loss by conduction, insulate with a material that has many tiny air pockets, which slow the movement of heat. To slow heat loss by radiation, use a "radiant barrier" like aluminum foil, which reflects heat.

When designing a device for heating or cooling, we want to consider the concepts of heat gain, heat loss and heat storage. Heat gain just means heat is moving into or being generated in the device, heat loss means heat moving out of it. For cooking, we want to maximize heat gain and heat storage (within reasonable levels) and minimize heat loss. For cooling food to keep it fresh, we want to maximize heat loss and heat storage, and minimize heat gain.

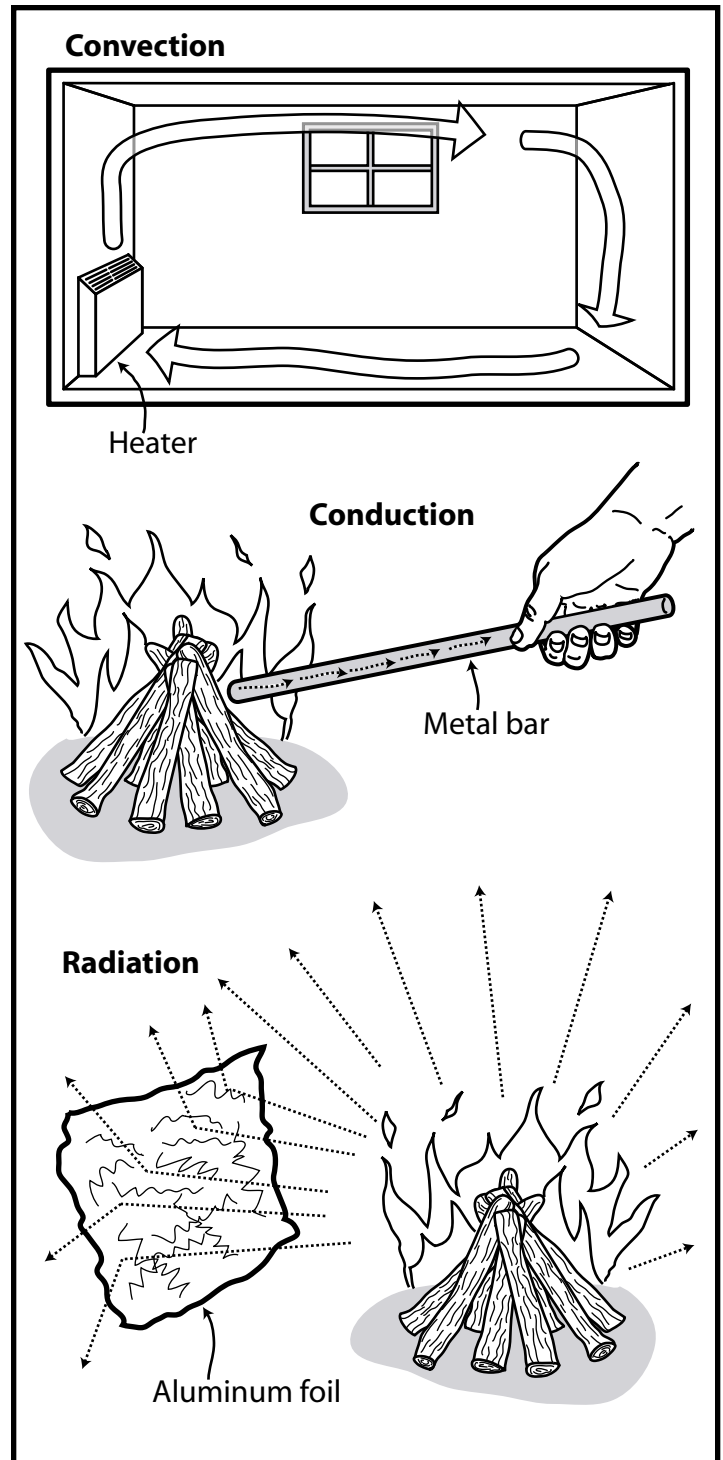

Cool Food Storage

Keeping food cool, as we all know, extends the storage life. Ideally, this means reducing food wastage, and hopefully reducing negative impacts on the landbase.

In keeping things cool, we want to minimize heat gain to our cooler, maximize heat loss, and maximize heat storage. To minimize heat gain, we want to keep our cooler in the shade to avoid heat gains from sunlight. We also want to keep it away from hot objects - obviously, you shouldn't put your icebox right next to your wood stove. Keep it in the coolest place that you can. Insulation around the cooler is important, since it stops heat from getting in to warm the food.

There are a few different techniques to maximize heat loss. Evaporation is an excellent way to carry heat away from your cooler, the way that sweat carries heat away from your skin to cool you down. Modern refrigerators use a fluid which is evaporated and condensed in pressurized coils, which is a variation on this basic idea. Heat can also be carried away by conduction, such as by a cool stream in which jars of food are placed, or by cool, moist earth underground. Adding ice is another way to get rid of heat. The ice cools the compartment, and as the ice melts, the draining trickle carries the heat away.

Maximizing heat storage, within reasonable limits, is important to moderate temperature variations that happen because of short term changes in weather, like cool nights and warm days, or because of the opening of a cooler door. Cold holes and root cellars use the thermal mass of the earth itself, which absorbs away extra heat. We will discuss tools which use all of these approaches.

A note on Food Safety

Without regular, industrial refrigeration, people may be confused about just how safe different sorts of food are.

Smell food to check for spoilage, but remember that food that smells fine isn't necessarily safe.

Fruits and Vegetables: Do not generally need to be refrigerated, but should be kept as cool as possible. Apples and some other fruits release a gas (ethylene) which causes ripening, so many fruits and vegetables will keep longer if kept separate from apples.

Meats: Large, solid, whole pieces of meat from mammals, like rump roasts will last the longest. Uncured sausage lacks preservatives, and may spoil. Chopped, raw meats, like hamburger will spoil quickly, and should be eaten as soon as possible; even if kept relatively cool, they may spoil in as little as twelve hours.

Dairy: Hard cheeses will last a long time at room temperature. Soft cheeses like cream cheese will spoil more quickly - watch for bad flavour or mold. Unrefrigerated milk spoils quickly, but sour milk can be used for baking, or to make cheeses.

Custard, gravies, creamed foods, chopped meats, poultry and seafood sandwich fillings are foods which will spoil very quickly when brought to room temperature.

Canned food which has been frozen may still be edible, if it looks and smells good. However, **do not taste it!** Food from cans which are burst or punctured should not be eaten. If you do eat food from cans which are suspect but probably safe, you should still boil the food for at least 10 to 20 minutes to avoid botulism.

Food Safety Notes:

"Safety of Refrigerated Foods After a Power Failure," University of Florida Institute of Food and Agricultural Sciences, 1997.

Water Immersion

A "spring house" is a shed or insulated chest built over or adjacent to a spring or small, cold stream. Inside, the water flows through a tray, in which you place containers of food to be kept cold. A similar system could work at the edge of a cold lake or river - water could be channelled into the tray, or a covered cage could be securely placed in the water. Watertight jars are very helpful in this kind of cooler. Shade will also help on sunny days.

Cold Room

A cold room is just a room in your house which is kept as cold as possible. It should be on the shady side of the house. I have seen very effective, insulated cold rooms which have vents that are opened at night to let cold air in, and closed in the day to keep warm air out. These cold rooms can be as effective as refrigerators most of the

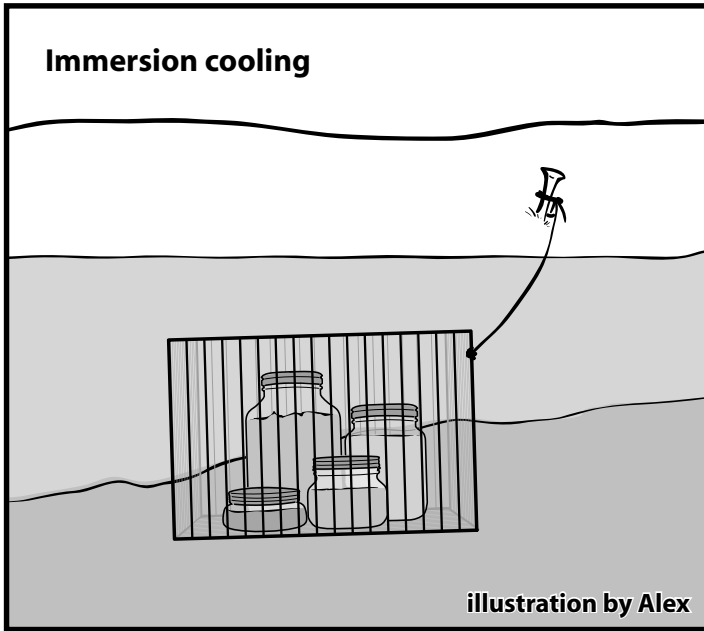

year in cooler climates, and are much more spacious. An example is illustrated at right.

In-ground Cooling

Root cellars, cold cellars, and cold holes all use the cool-ness of the earth.

A cold hole is simply a well-like tunnel dug down into the earth. The sides can be secured with old metal barrels, stacked on top of each other with the tops and bottoms removed. The food is put into a crate or bucket, and lowered on a rope into the hole, which is kept covered. It can be as little as a few feet deep, or ten or more, as appropriate. The depth of the water table is a limiting factor.

A cold cellar, also called a root cellar, is a room built into the ground often part of a house.

Small scale improvised “root cellars” are actually very easy to make. If you have an old refrigerator, you can remove the electrical connections (and anything else you might want to salvage or keep out of the ground) and bury it, back side down, in the ground. Leave just a few inches and the door above ground. The shelves form ready-made vegetable storage compartments. For climates with very cold winters, pile straw, leaves, or other mulches on top of the “cellar”.

Any large containers buried in the ground can serve the same function. Try barrels, or garbage cans. However, make sure to keep them away from moisture and puddles, because you don’t want water to seep in and freeze

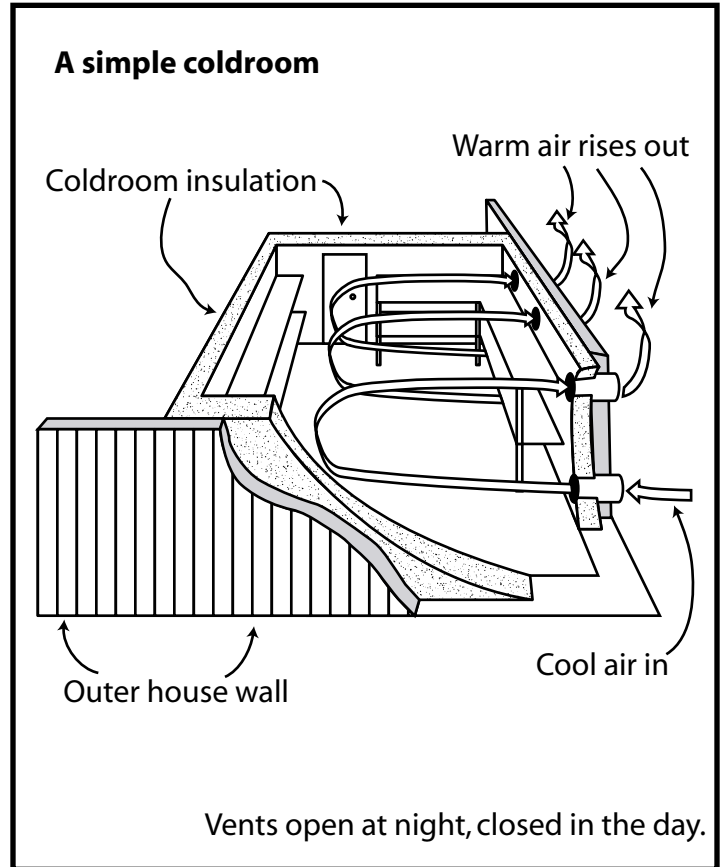

the crops, or to freeze the container shut. Make sure that the container has a top which closes tightly enough to keep out rodents. And put a deep layer of leaves or straw overtop, to insulate and keep snow off. You may need to put boards, a tarp, or chicken wire overtop of the insulation to keep it in place.

If you have access to bales of hay or straw, you can make a wire or metal box on the ground, to keep out rodents, and stack square bales around it. You can also line the box with styrofoam or other extra insulation.

Keep storage fruits and vegetables separate, and they will last longer. Many vegetables can be stored in root cellars including potatoes, carrots, beets, turnips, salsify and parsnips. Different vegetables have different temperature and humidity requirements. Please see below. Asterisk (*) means short term storage only.

Cold and Very Moist:

(0-5°C / 32-40°F and 90-95% relative humidity)

Carrots	Beets	Parsnips
Rutabagas	Turnips	Celery
Chinese Cabbage	Celeriac	Leeks
Salsify*	Winter Radishes	Kohlrabi
Collards*	Broccoli*	
Horseradish*	Jerusalem Artichokes	

Basement root cellar

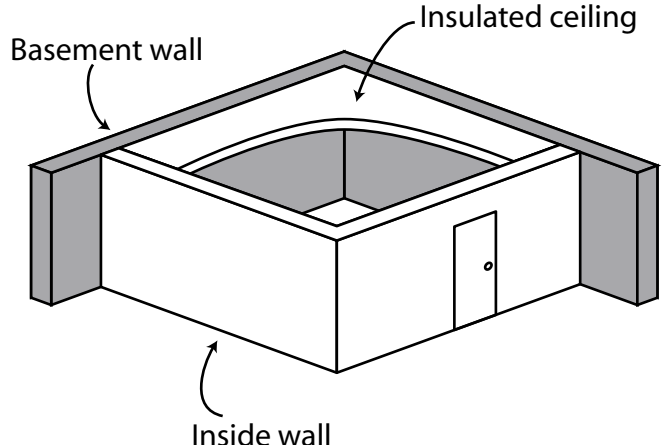
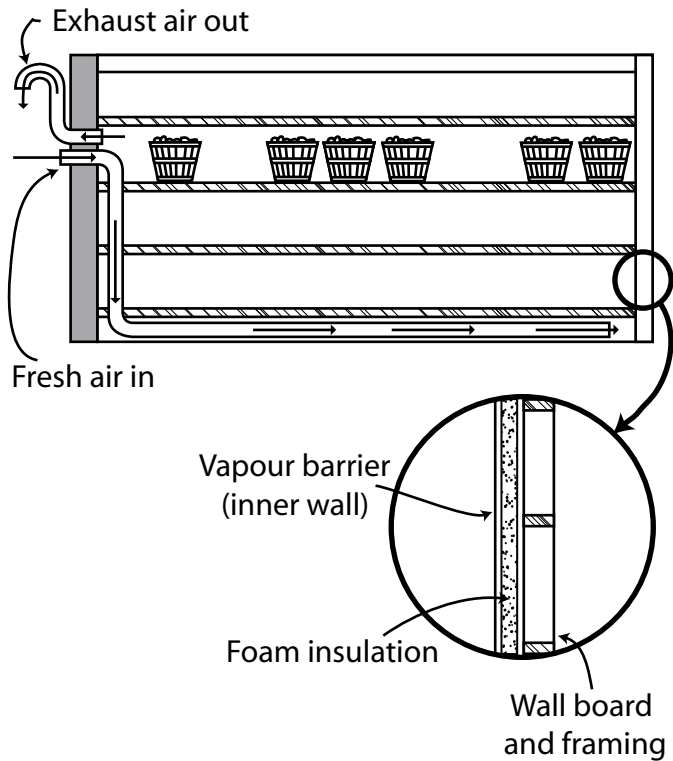

Barrel root cellar

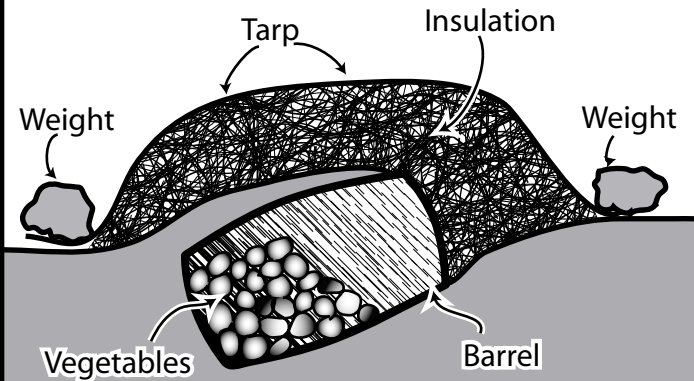

Cold and Moist:

(0-5°C / 32-40°F and 80-90% relative humidity)

- | | | |
|----------------------|--------------|--------|
| Potatoes | Cabbage | Apples |
| Oranges | Grapefruit | Pears |
| Grapes* (5°C / 40°F) | Cauliflower* | |

Cool and Moist:

(5-10°C / 40-50°F and 85-90% relative humidity)

- | | |
|----------------|-----------------------------------|
| Cucumbers* | Cantaloupe |
| Muskmelon | Sweet Peppers* (7-13°C / 45-55°F) |
| Watermelon | Eggplant* (6-10°C / 50-60°F) |
| Ripe Tomatoes* | |

Cool and Dry:

(0-10°C / 32-50°F and 60-70% relative humidity)

- Garlic (keeps best around 50% humidity)
- Onions
- Green Soybeans in the Pod*

Moderately Warm and Dry:

(6-10°C / 50-60°F and 60-70% relative humidity)

- Dry Hot Peppers
- Pumpkins
- Sweet Potatoes
- Winter Squash
- Green Tomatoes (as high as 70% humidity)

Root cellar notes:

An excellent resource is "Root Cellaring: Natural Cold Storage of Fruits and Vegetables" by Mike and Nancy Bubel.

Ice Caves / Ice Houses

In climates where a significant amount of ice forms in the winter, or even where a decent amount of snow falls, this technique might be applicable. Ice caves and ice houses are designed to store ice from winter for use later on.

Ice caves can be dug into the northern side of hills (in the northern hemisphere), or a very well insulated shed or shack can be built. In either case, insulation such as straw is put onto the ground and between the blocks of ice. You may want to provide a drainage channel of some sort for meltwater, depending on your design and climate conditions.

Historically, ice was usually cut from bodies of water and dragged to the storage space. If you don't have access to a body of water which freezes over with enough ice, you can pile up snow and walk on it with snowshoes and boots to tramp it down. Try to compress it as much as possible, and then leave it for a few hours to solidify. Then cut blocks and store them as with ice. However,

the compressed snow blocks will not last as long because they are much less dense (any given volume of snow is 90% air), and probably won't be as clean as the ice blocks.

Ice Boxes

An ice box is a simple, insulated box or cooler, into which ice is placed. The ice will last longer if there is a tube to drain water away from the ice as it melts. The ice usually has a tray or compartment at the top of the cooler, if possible, since the cold air sinks down.

Vapour Pantry / Pot-in-pot Cooler

These two techniques work by evaporative cooling, the same way that sweating cools you down.

You can build a simple vapour pantry by using a (preferably waterproof) container, such as a small cupboard, or a barrel with an access door cut in the side. Place a tray of water on top of the container. Affix the edges of several (damp) towels in the tray, and let them hang over the sides of the container. The water in the tray will be "wicked" into the towels, keeping them damp.

The pot-in-pot fridge was recently adapted and popular-

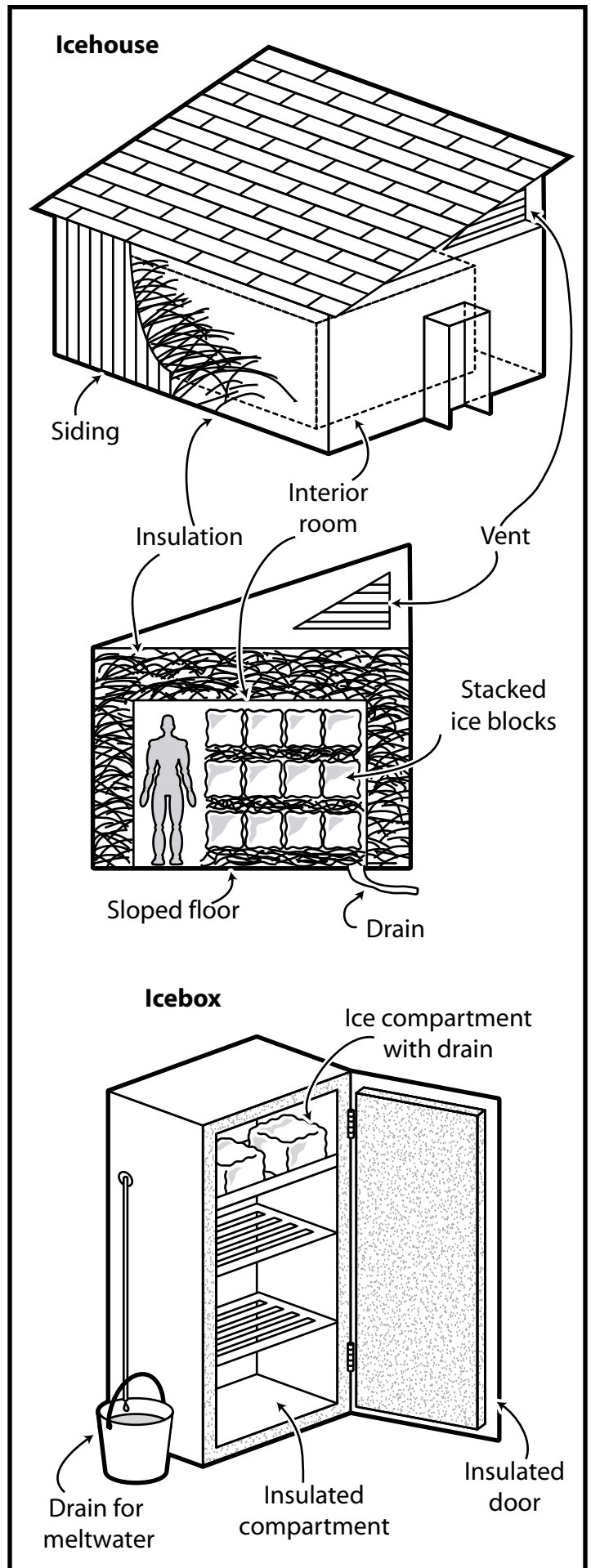

ized by Mohammed Bah Abba. It's very simple. Place one pot inside a larger pot. Fill the space in between them with wet sand (which is rewetted regularly), and cover the top with a wet cloth. If the outside pot is unglazed, water can evaporate through it more easily.

Both of these techniques will work best in relatively dry and well ventilated, preferably windy, areas. You can try putting these outside (but in the shade) so that they are exposed to more wind. Alternatively, you can put a device working by evaporation in the wall of your house, so that you can access the food from inside and protect it from scavengers, but let the wind outside help with the cooling.

You can also use a system with two buckets, one full of water, and the other full of food. This can be hung from a (shady) tree, with the water bucket on top. A cloth is draped over both buckets, with part of it immersed in the water. It works in much the same way as the first example above.

Salvaged and Modified Refrigerators

It is possible to modify some refrigeration equipment so that it does not need to run on electricity, but can run directly off of some other motive force. I have seen a chest freezer which runs (quite well) with the compressor running off of a water wheel, using no electricity. However, this wouldn't be appropriate for most people, so I won't go into any more detail here.

There is another type of refrigerator that would be appropriate for salvaging. The type of fridge used in RVs does not have any moving parts, and runs on the heat from burning propane or gas. This type could be modified to run off of a fire created by wood, biodigested methane, or any other source of sufficient heat. A fridge working on this principle could even be solar powered.

For information on RV-type refrigerators (ammonia type) see <http://www.nh3tech.org/absorption.html> or a book on refrigeration.

Cooling Notes

The Encyclopedia of Country Living, by Carla Emery.

Fieldbook for Canadian Scouting, Boy Scouts of Canada, 1986

Cooking

There are a few basic concepts involved in cooking, and in designing cookers that will cook as rapidly, efficiently and conveniently as possible. These include heat gain, heat loss, and heat storage.

Heat gain is the heat that actually enters the cooker from solar energy, either by direct sunlight, or through the solar energy released by burning wood and other potential fuels. Heat loss is heat that escapes through the means of heat movement discussed above.

For wood cooking, remember that smoke is uncombusted fuel. A very efficient fire is almost smokeless, which means that fuel and trees are being conserved, and that air pollution is minimized. To make a fire efficient, you want to keep the temperature of the fire as high as possible, above 600°C (1100°F). This means regulating and warming the supply of air, if possible. It may also mean insulating the combustion chamber, and using low-mass materials for building the stove so that the heat is contained and concentrated.

For cooking in general, you can save a lot of fuel (and cooking time) by cutting food into small pieces, grinding up grains, pre-soaking dried beans overnight, and using minimal water. The food will cook more quickly if steamed rather than boiled, because the water will absorb a lot of the heat. Always use a lid when cooking.

Hayboxes

A haybox is an insulated container which can make significant fuel savings - up to 70%! Just bring the food to a boil, place the pot inside the haybox, and cover. The haybox will contain the heat in the food so that it will continue cooking without using extra fuel. In terms of our three heat concepts, a haybox works by maximizing heat storage and minimizing heat loss. A haybox is ideal for foods with a high water content like soups, stews, rice, boiled eggs and more. Foods which lose a lot of steam on the stove can be cooked with less water using a haybox.

You can precook the beans and legumes in some recipes,

such as chili, in the haybox before adding other ingredients, since some beans must be boiled for at least 10 to 15 minutes to make them safe to eat.

Hayboxes can also be used to raise bread or incubate yogurt or tempeh. Place a container of hot water in the haybox to keep the temperature up.

You can use a cooler as part of a haybox, but you will probably want to add more insulation. You can make a

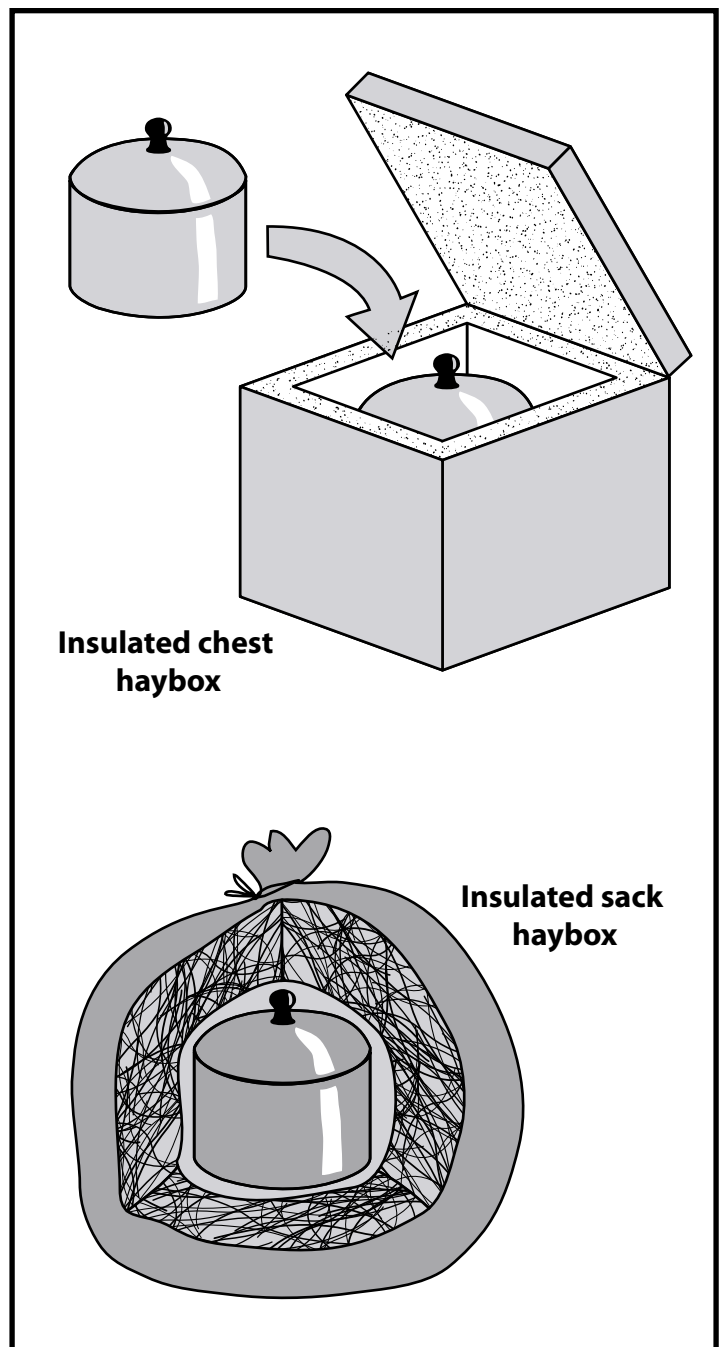

haybox from all sorts of local materials, such as a basket filled with dried grass and covered with a bag or pillowcase of dried grass on top.

Cooking times:

Food:	Boil time:	Haybox time:
Rice	5 min	1-1.5 hours
Potatoes	5 min	1-2 h
Soup and stock	10 min	2-3 h
Green Lentils	10 min	3-4 h
Pintos	10 min	3 h
Split Peas	10 min	2 h
Quinoa	5 min	1.5 h
Millet	5 min	1 h
Polenta	1 min	1 h
Winter Squash	5 min	1-2 h
Steamed bread	30 min	3 h
Chicken	6 min	2-3 h
Beef	13 min	3-4 h

Haybox Notes:

Aprovecho's Guide to Hayboxes and Fireless Cooking, by Peter Scott, et al. Aprovecho Research Centre. (Brochure)

Fireless Cooking, by Heidi Kirschner, Madrona Publishers. 1981.

Efficient Wood-Burning

We can save fuel, trees, time spent gathering wood, and also reduce air pollution by using fuel efficient stoves.

Stove efficiency is based on two main factors. One, an efficient stove converts as much of the energy in the wood as possible into heat. Two, an efficient stove transfers as much of the heat as possible into the food being cooked. If we say that a given stove is 10% efficient, that means 10% of the energy in the burning wood goes into the food.

Not all woodstoves are very efficient. Some lose enormous amounts of heat by heating up large metal bodies, which then lose more heat to the ground and air around them. If you want to boil a 2 kg pot of beans, there is no need to heat up 300 kilograms of steel as well.

We will look at open fires, which can be between 8% and 18% efficient, or better, depending on the skill of the fire builder, the type of fire, and the windiness. We will also look at the Winiarski Rocket Stove, which can be more than 24% efficient, and the Dona Justa Stove, which can be more than 40% efficient. *Please exercise caution and be safe when building fires or stoves.*

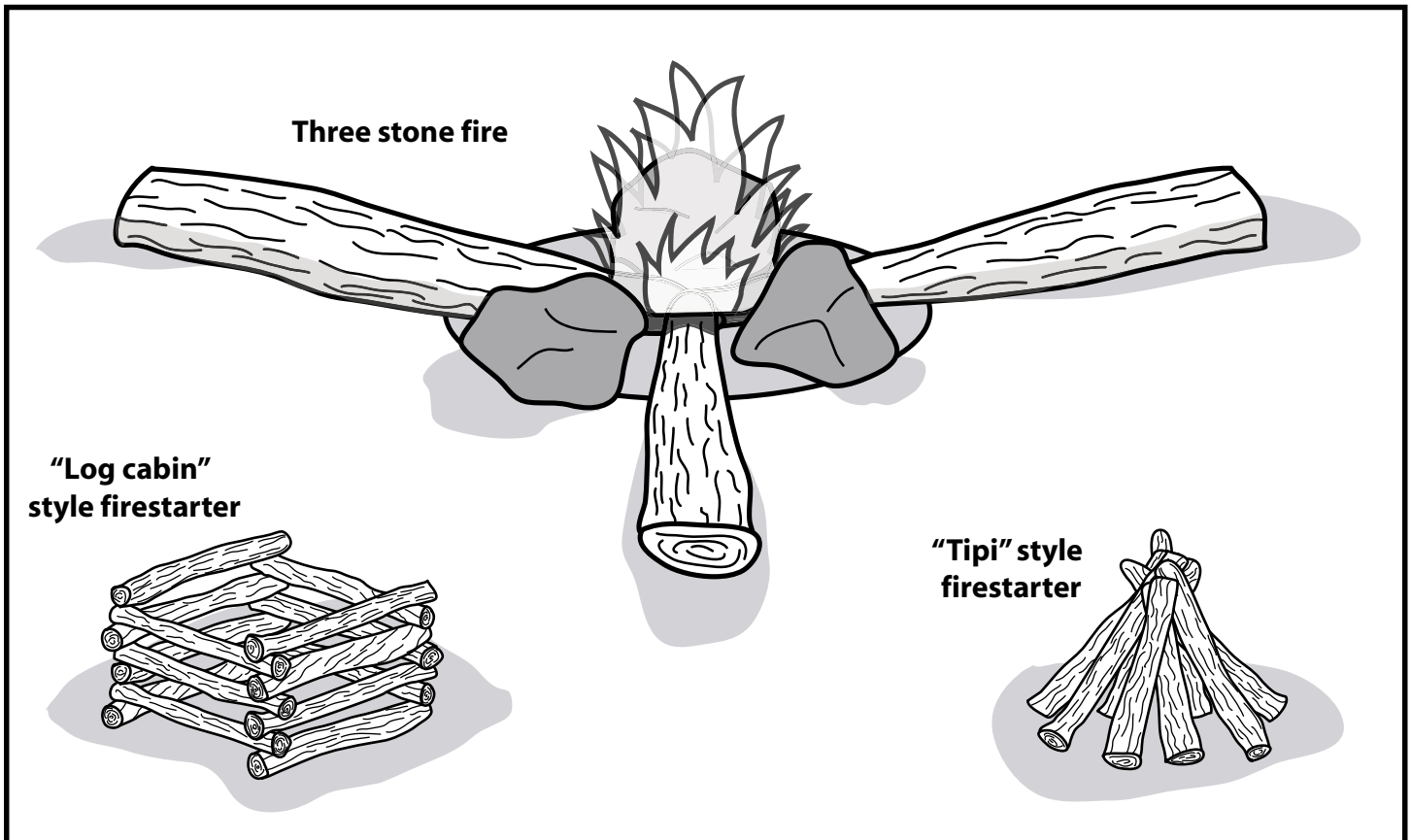

Open Fires

Building an open fire

To build a fire, you want to start with very fine, dry pieces of flammable materials, called “tinder”. This could include moss, shredded paper, birch or cedar bark, or wood shavings. This material is the easiest to light. On top of that you loosely stack larger materials, “kindling”, such as pencil-diameter sticks and twigs or rolled-up newspaper. Then on top of that you put the largest pieces of wood, the “fuel”. You can also make a “fuzz-stick” with your knife by making wood shavings from a stick, and leaving them attached. In very wet weather, you can split open a log which is dry inside, and make “fuzz” from the interior.

There are two easy ways to stack the materials when starting a fire, “log cabin” or “tipi” style. A log cabin pile has the tinder at the bottom inside, and the kindling stacking criss-crossed, as shown. A tipi style has the sticks leaning into each other, or some with their ends stuck into the ground for stability. One advantage is that the sticks will fall into the fire as it burns. For both types you need to leave spaces for air flow. Firemaking is a skill that takes practice, and you’ll get better and better at it as you do it more.

Three stone fire

If you have long logs for fuel, don’t waste time and energy sawing or chopping them. Just put three large stones around the fire to reflect and retain heat, and then stick the ends of the logs in. As they burn, push them in further and further, until they are gone.

There are a lot of ways to cook on an open fire. You can place a grill on top, and cook meat or some vegetables. You can place pots or pans on the grill. You can hang pots from a “crane” or “spit”. Just drive two forked sticks into the ground, and place another stick between them.

If you are more of an expert at building up a coal bed, you can rake the coals out of the fire, and cook meat or vegetables right on top of them.

In very improvised circumstances, you can make a hole in the ground and line it with some waterproof membrane. Put in water (and food). Then heat rocks in the fire and drop them into the water or “stew” so that it boils.

You can also wrap food (such as potatoes) in aluminum foil, and place them near the fire, in the coals, or even bury them in the coals of the fire and cook them overnight. If you don’t have foil, you can cut the ends off of two aluminum cans, place the food in one, and then jam the other over as a cover.

Another improvised way of cooking is to make a fire in a pit, and burn it down to a coal bed. You may want to place rocks inside as well. Cover the coals with a thick layer of non-poisonous leaves. Then put on a layer of the food you want to cook, then another layer of leaves, and then dirt or sands as a cover. The heat and steam will be trapped inside, cooking your food.

Remember, *never use rocks from a riverbed or other wet place* to put in or near your fire. They may have water trapped inside, which could boil and cause the rocks to explode.

Hearth variations

The efficiency of the open fire drops a lot when it is windy. There are a number of ways to deal with this. You can lay two logs down on either side of the fire, or make a “U” shaped hearth with rocks. Wind blowing into the hearth will feed the fire with air. You can also dig a shallow trench a few feet long, about a foot deep, and wide enough for your pots to straddle the opening.

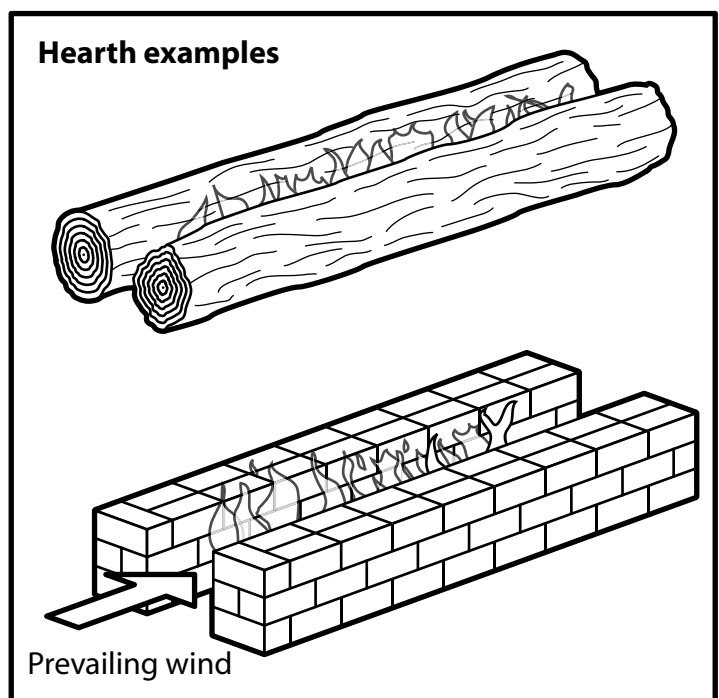

Winiarski / Aprovecho rocket stove

Stove elbow

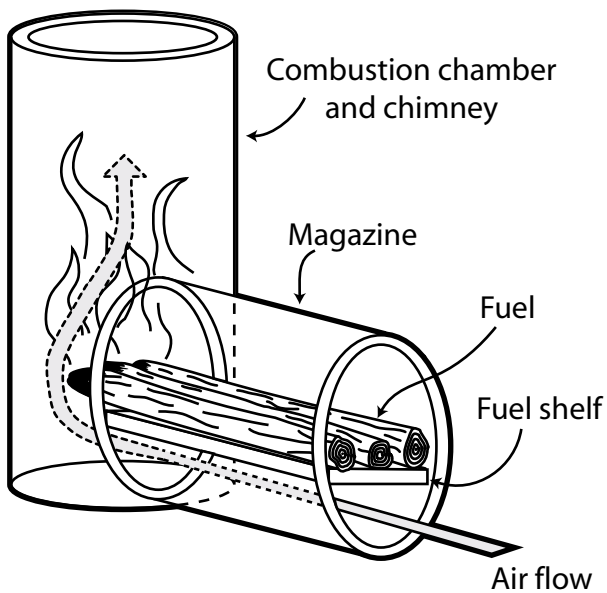

Full assembly

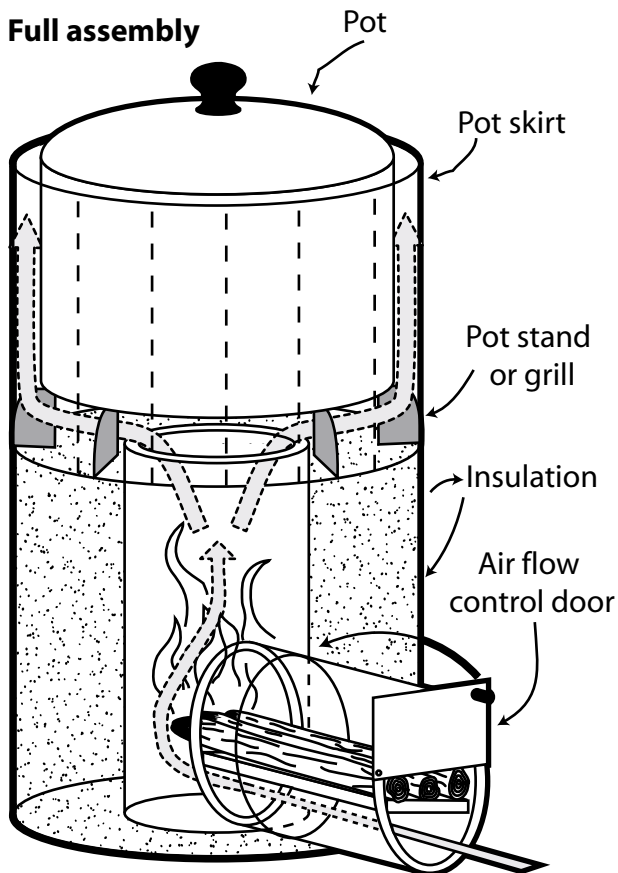

Fire hole

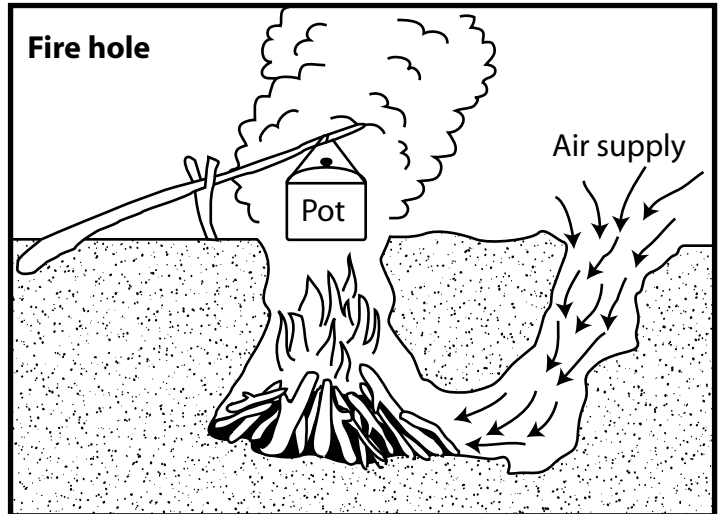

Fire hole

A bit more elaborate, and probably the best style of fire for high winds, is this fire hole. Dig a U-shaped hole, as shown, and start a fire in one end. You can feed in fuel through the other. Place your pot, elevated on sticks to allow air flow, over the side with the fire.

Efficient Woodstoves

There are a lot of different designs for improvised stoves out there, some better than others.

You can make a very simple improvised stove with a metal paint can. Remove the lid, and punch several large holes at the bottom of one side and the top of the other. Turn the side with the holes on the bottom into the wind, and place your pot on top.

However, there are more efficient stoves to use. We will look at two stoves designed by the Aprovecho Research Center, in Oregon.

Winiarski Rocket Stove

The brilliant Rocket Stove was developed by Dr. Larry Winiarski and the Aprovecho Research Center.

This excellent design is a combination of a number of design principles:

- Insulation around the fire keeps the fire burning hot (above 600°C or 1100°F), which is more efficient.
- Insulation around the chimney increases the draft, which provides a constant supply of air.
- Low mass materials are used, so that the heat produced is absorbed by the food cooking instead of the stove.

- Wood burns at the tip, and wood is shoved into the fire, controlling the burn rate and reducing smoke.
- The air/fuel mixture is controlled, since too much air will only cool the fire.
- A skirt around the pot maximizes heat contact and transfer into the food.
- Cooking occurs directly on top of the chimney for efficient heat transfer. This is possible because the stove burns at high temperatures and is nearly smokeless.

The Rocket stove design is a very versatile design which can be improvised with a variety of different materials.

The heart of the stove is an elbow-shaped, insulated combustion chamber. The fuel, in the form of sticks or narrow pieces of wood (or even tightly rolled-up paper, if that's all you have), is fed into the fire on the shelf, as shown. The air enters into the fire underneath the shelf. Because the combustion chamber is insulated, the fire can get very hot, and burn very efficiently.

To build a rocket stove, you will need a larger housing container, such as a coffee can. Make a hole to put the fuel in through.

For the elbow-shaped chamber you can use stove-pipe, scrap metal, or a pair of cans put one into the other. An improvised can chamber will last for about 3 months. Plastering the inside with castable firebrick will improve the lifespan. A taller chimney will be more smokeless. However, a shorter chimney will let the flame touch the bottom of the pot, and transfer heat more efficiently to the food.

Place the elbow joint inside of the larger container. You may need to place a brick or other material underneath to help keep the placement. Then fill the space between the elbow and the housing with fireproof insulation. This insulation could include wood ash, vermiculite, perlite, pumice rock, dead coral or air-trapping layers of aluminum foil.

You will need to make a shelf for the fuel wood to put in the elbow joint. You can pound a can flat, and cut it to fit.

You may want to make a wire grill to place on top of the housing, to rest the pot on.

Adding a metal skirt will also help the heat transfer

tremendously, because it will force the hot gases to rub against more of the pot, as shown. The skirt should be about 1 cm from the pot.

Starting a Rocket stove is a little bit different from starting an open fire. Try putting your tinder on the shelf, igniting it, and then pushing the fuel in.

Dona Justa Stove

The Dona Justa stove is an extension of the rocket stove concept, and is another Aprovecho design. It is designed to be used inside, so there is a long chimney which vents the (minimal) smoke outside. The hot gases from the combustion chamber move up and across the bottom of a metal cooking surface. The underside of this passage is insulated to retain heat. The smoke then goes up the chimney and outside.

The downside for efficiency of this stove is that the metal cooking surface will release heat into the air wherever it is not touching a pot. You can improve the efficiency of this stove by making holes in the surface so that the pots can be put into the channel where the hot gases travel. This contact improves heat transfer. You can build a form-fitting channel, as shown, so that the gases are forced to go as tightly as possible against the pots.

See the following page for an illustration.

Solar cooking

Heat gain in solar cooking comes from a few main sources:

- The Greenhouse effect, where light travels through the glass or transparent plastic and hits objects inside, but the heat is unable to get back out through the glass.
- Glass orientation (glazing) is another consideration. More light will travel through the glass if it is at a right angle to the light coming in. Otherwise, part of the light will reflect away.
- Reflectors direct more light towards the pot or oven.

There is a wide variety of creative solar collectors for use in cooking, and I encourage you to check out different varieties to see what might work best for you.

Tips for solar cooking:

- Use dark pots with lids.

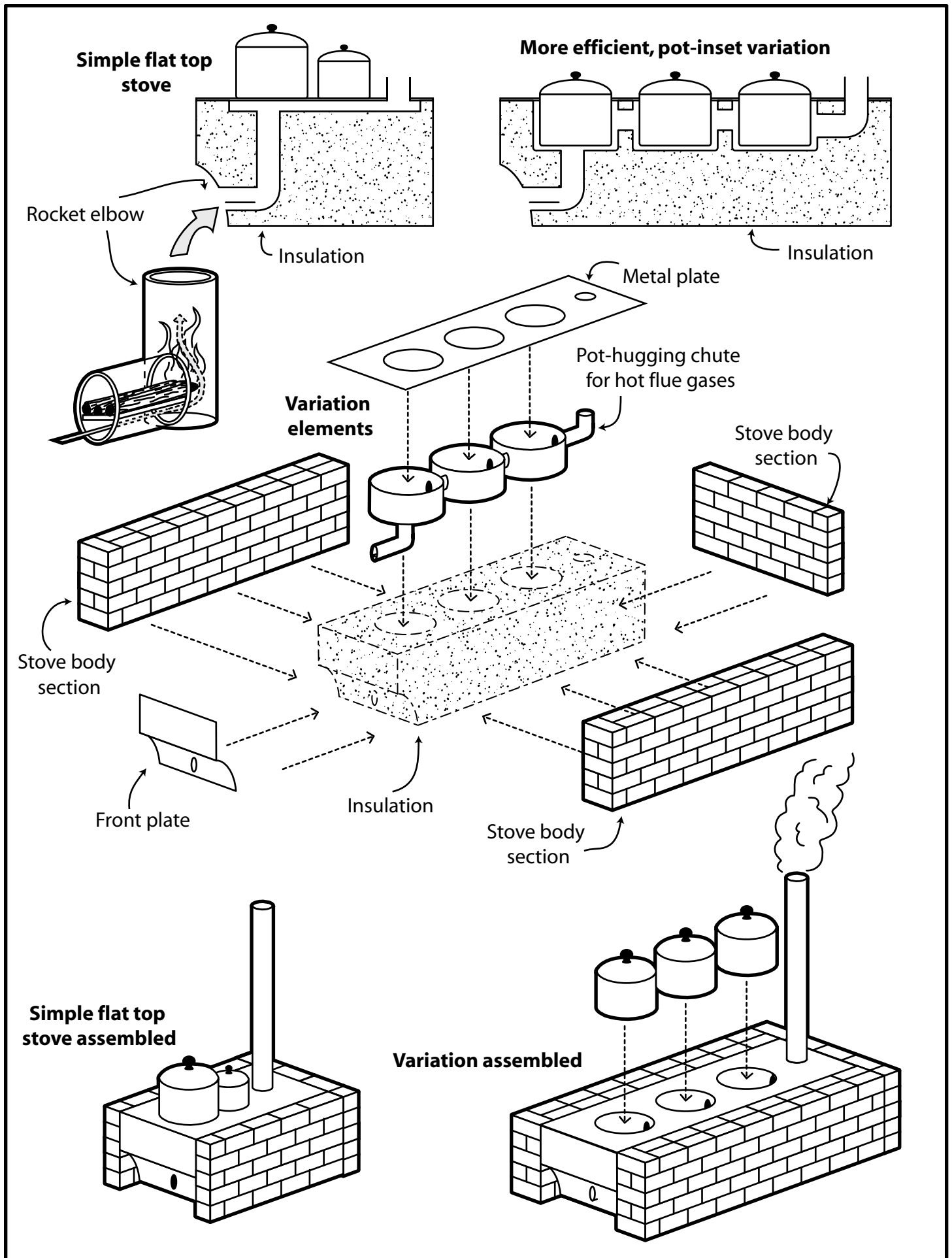

- Don't open the pot while cooking. The temperature is lower than other types of cooking, so you don't need to stir because sticking and burning is rare.
- Put the food on early, because solar cooking takes longer than other sorts of cooking.
- Adjust the solar cooker regularly to follow the sun.

If you double the scale of a solar cooker design, you increase the amount of light captured by a factor of four.

For solar reflectors, you can use whatever materials you have available to you. You can paste aluminum foil onto corrugated cardboard. Make sure that the foil is on smoothly because wrinkles will impair the focus. Contact cement seems to work well as an adhesive, though other improvised glues will be covered in future writings. You can also use polished sheet aluminum or other polished sheet metals, or aluminized mylar.

Simple folding solar cooker

This is the simplest, most portable, and lowest temperature cooker of the solar cooker designs here. However, it can be built quickly and easily out of basic materials, and will still work well on brighter days or in brighter latitudes.

If you place a black pot in a clear plastic bag as shown, you will have better heat-retention. A simple wire frame can prevent the bag from touching (and melting) on the pot. It will also keep the pot off of the ground, reducing heat losses from conduction.

This solar design (as well as the others) can be used to boil or disinfect water for safety (see *Treating Water*, p.9)

If you have time and access to materials it might be a good idea to build a larger and more effective model.

Solar Oven

This is the next simplest design. It requires a small glass pane, which can be salvaged from any number of sources. This design is derived from the work of Dr. Maria Telkes, a 1950's solar pioneer and appropriate technologist.

You'll need to make an insulated box like the one in this illustration. For improvised insulation, you can use alternating layers of aluminum foil and corrugated cardboard. You can also use wood ash, charcoal, etc. The top of the box is an angled window, and the back has a door

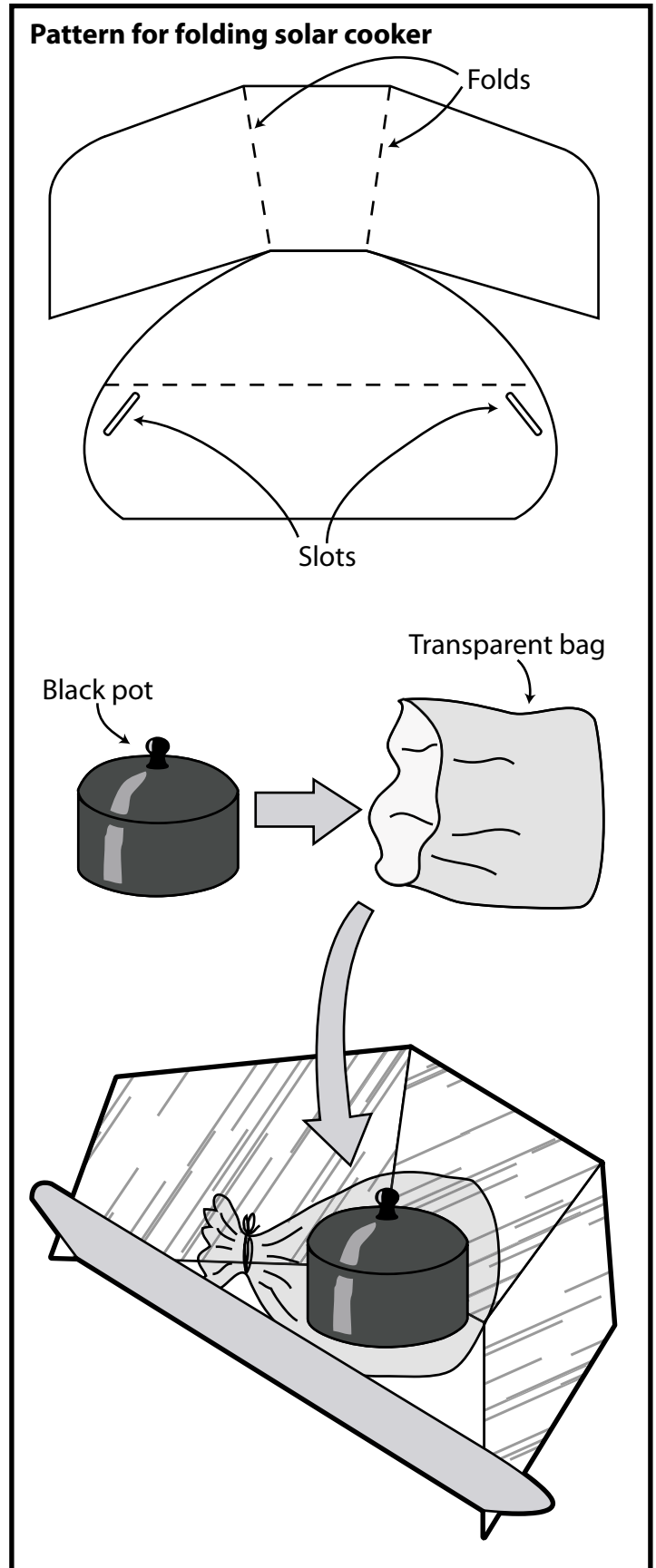

Telkes solar oven

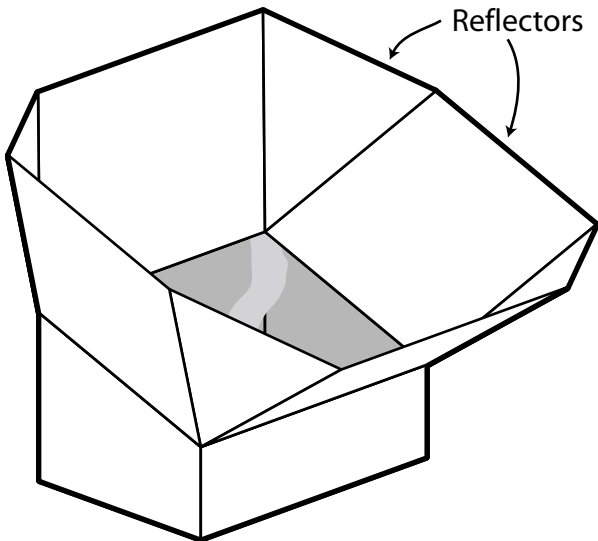
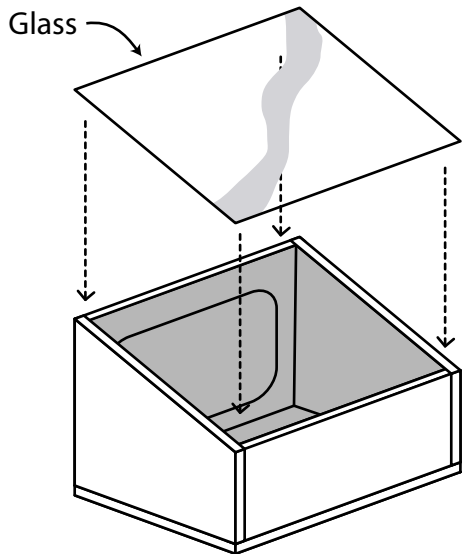
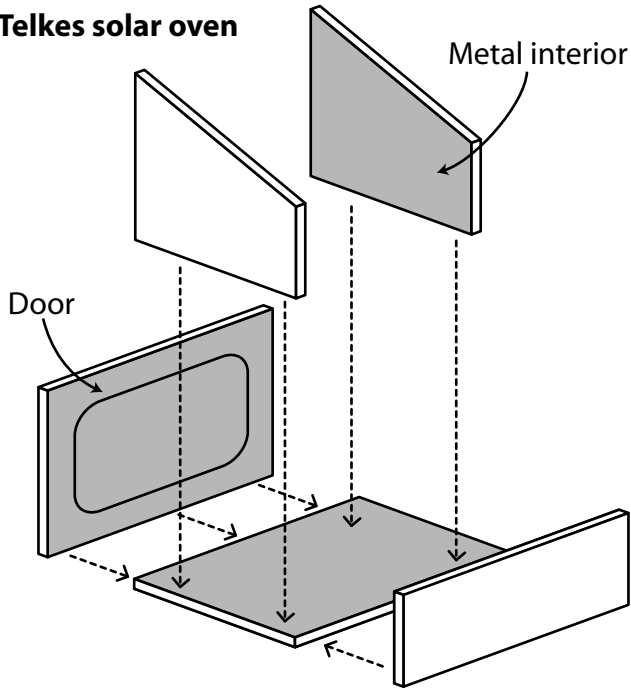

to access the food. You can use plywood for the main structure of the box, or any other improvised material.

To decide the ideal angle of the glass for this cooker (and the solar still in the section on water) take your latitude and subtract it from the number 90. This is the noon-time average annual angle of the sun in the sky. Add 23.5 to get the sun's noontime angle on the summer solstice, and subtract 23.5 to get the sun's noontime angle at winter solstice. Pick the best angle, considering that the glass would ideally be at an angle of 90 degrees to the sun. If you mostly cook in the summer, then you will want to use an angle between your average and summer solstice noon-time angles.

Ideally, the interior of the oven is lined with black-painted metal, to absorb as much light as possible and turn it into heat. Use water-based paint. (Before using your oven, let it "bake" empty in the sun for a couple of days to get rid of harmful gases from the paint.)

Then mount reflective panels as shown to reflect the sunlight into the oven. An angle of about 30 degrees from the sun (or 120 degrees from the glass), as shown, works best.

You'll want to have a relatively easy way to adjust the position of the collector to follow the sun. The oven illustrated is simply mounted on skids. You'll probably want to adjust it about every 15 minutes or so. Experiment to see what works for you.

Reflectors (laid out flat)

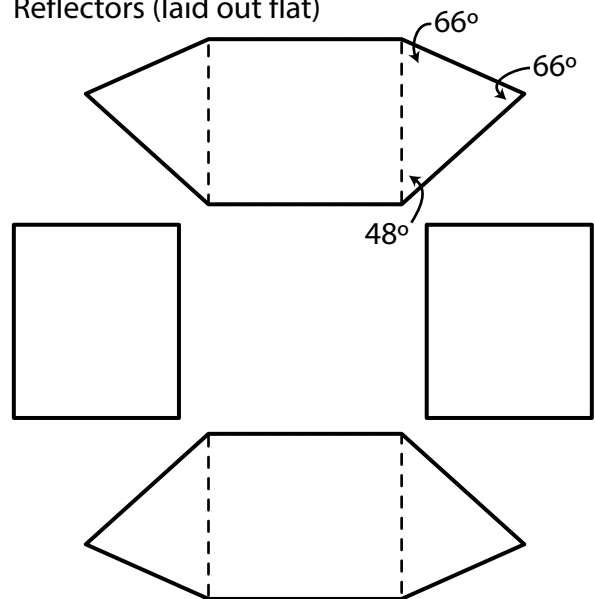

Parabolic cooker

The parabolic cooker is a bit more complicated, but works quite effectively if you can manage it. You can fry on a parabolic cooker. Here we will look at a few variations on the basic idea.

The basis of the parabolic cooker is the parabola, a curve which, as illustrated, will reflect incoming parallel rays (such as from the sun) onto a small point. This permits very high temperatures to be created. For this reason, there is an important warning: Do not look directly into the reflected sunlight. This could cause severe eye damage. For safety, make sure to put the focal point inside the cup of the reflector.

You can draw a parabola using a right-angle as shown at right, without any knowledge of mathematics. (Geometrically, a parabola is defined as a curve on which any point is the same distance from the focal point as it is from a base line, the “directrix”.) Place the nail where you would like the focal point to be. Always keep one arm of the right-angle against the nail, and the corner against the baseline. Start with the corner directly below the nail. Move the corner a little bit away from the centre each time, and draw a line from the baseline out towards the edge of the cardboard. Eventually you will have many lines which intersect along a curve. This thick composite curve is your parabola.

If you want, you can use the concave (cave-shaped) section of the parabola as a frame template for a collector like the one shown in the top right corner of the illustration on the following page. This is appropriate for heating water, or for cooking hot-dogs or shiskabobs. However, you may get a lot of heat loss from the food being cooked, since it is exposed, and has a lot of surface area. This loss can be reduced by sheltering the collector from the wind, and insulating the side of the food facing away from the collector.

If you use the convex section of the parabola, you can rotate it in clay to produce a mold, or make a framework like a spider’s web, with radial, parabolic arms, and then curved struts connecting them.

Once you’ve built your reflector, you will need to build a base which you can mount it on to rotate the reflector to follow the sun. You will also need some kind of pot holder, like the grille shown. Also, an alignment indi-

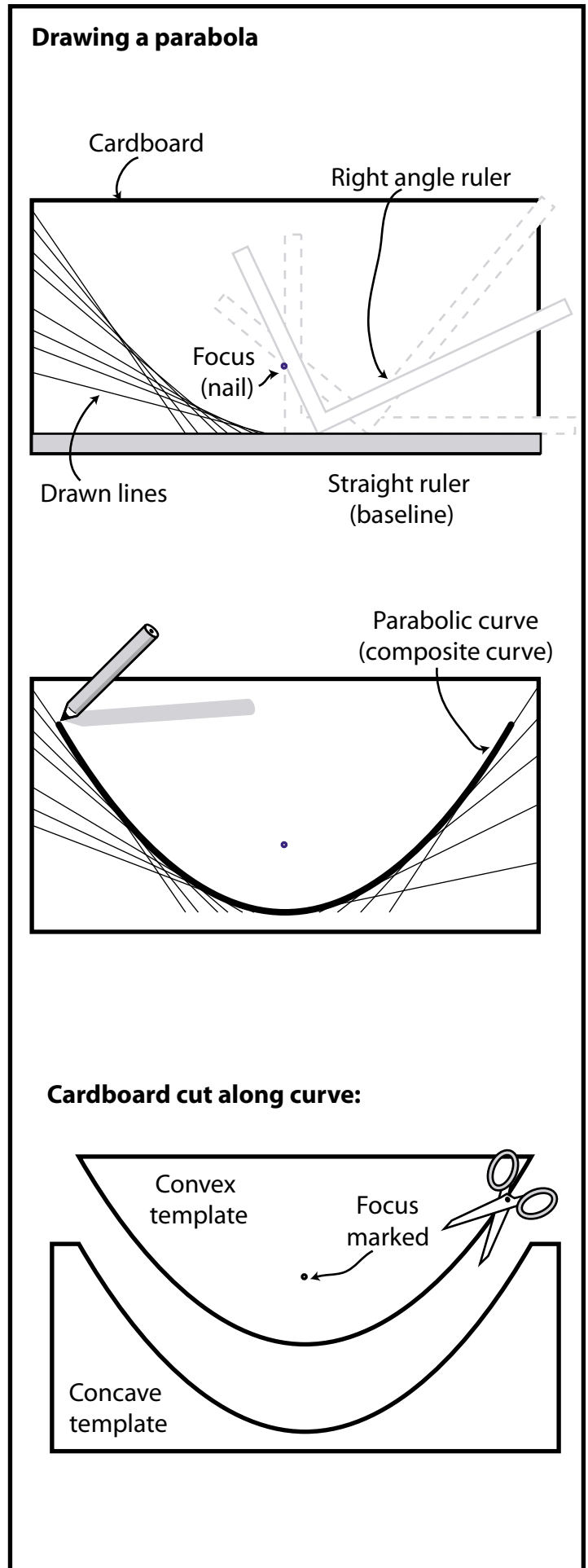

Turning a parabola in clay to make a mold for reflectors

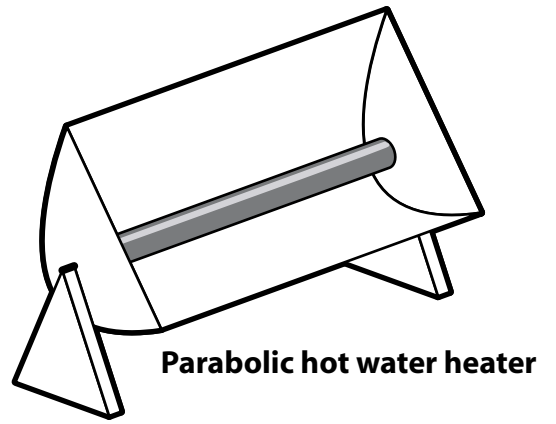
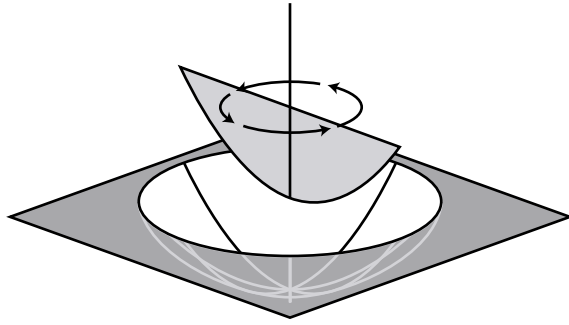

Making a folding parabolic reflector

Parabola template

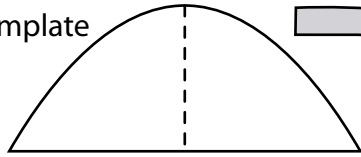

Fold template

Attachment tabs

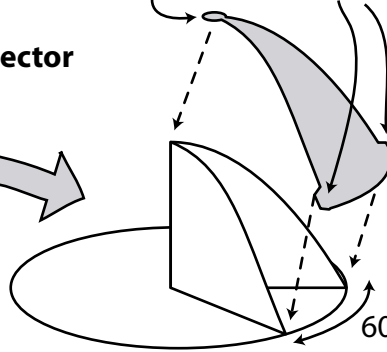

Connect sections at tabs when using

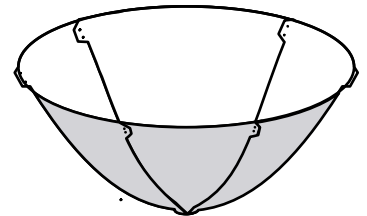

Parabolic Solar Reflector

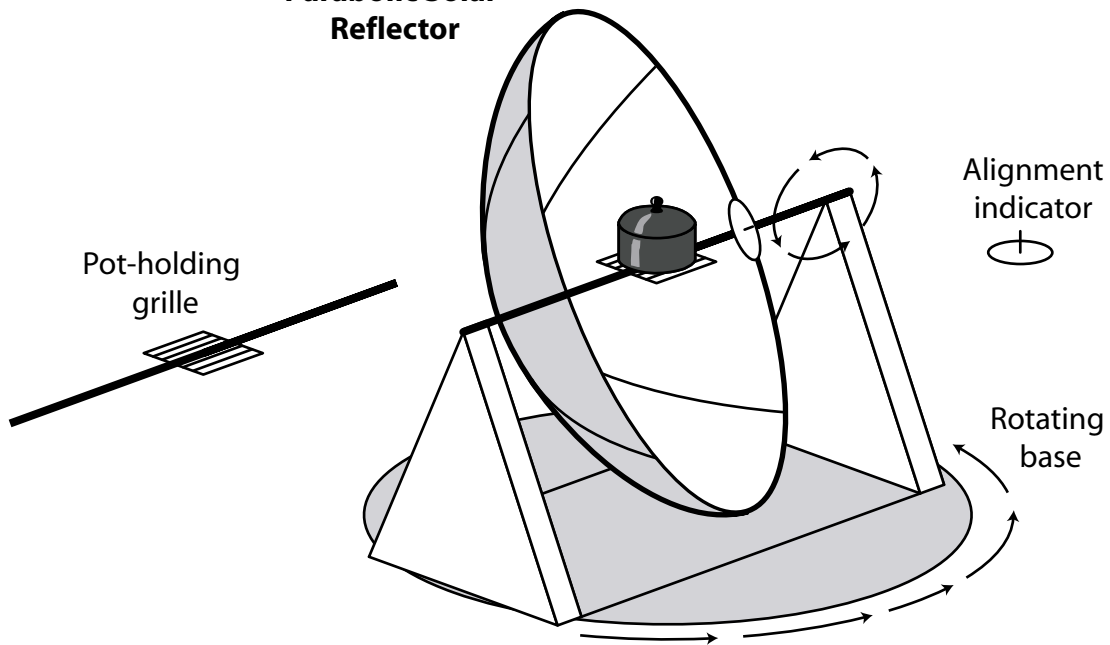

cator (which can be as simple as the circle with a post shown) will help you to line up your parabolic cooker with the sun. Just mount the post at 90° to the cooker. When the post casts no shadow, the collector is properly aligned.

If you make a template out of corrugated cardboard, you can fold it in the middle, as shown in the centre of the illustration, to make a template for a folding parabolic collector. This will not be as accurate as a true parabola, but it will probably be good enough for cooking. Lay a piece of aluminized mylar, or other shiny, relatively stiff material (even thin, polished sheet metal) over the template. Cut off the excess and leave tabs for attaching the other segments, as shown. You can copy the other segments from this original. Make the angle that you fold the template appropriate to the size of material you have available to you, but make sure that it will divide evenly in a circle. For instance, if you want to make a folding collector with six segments, divide 360° by six (to get 60°) and angle the two halves of the template 60° apart. For eight segments, use 45° , and so on.

It's worth noting that satellite dishes are also parabolic reflectors (for radio waves.) So if you can find one of the appropriate size (and especially one which can be adjusted for tracking) you may be able to cover it in reflective material and use the existing structure.

You can make the parabolic reflector out of a number of materials. They don't have to be aluminum foil - polished metal will do, and mirror pieces are even better.

In general, collectors larger than 2 metres (6.6 feet) across are considered unwieldy, but you can manage it if you have a sturdy mounting and avoid high winds.

If a parabola is too difficult, for boiling water you can also make a simple conical cooker. Cut a shape out of sheet-metal, or cardboard to glue aluminum foil on to. Remove 105.5° of the circle. Bring the edges together, as shown, to form a cone. The focus of the collector is a line along the center of the cone. You can use a black pipe of water as the container, or make a long black metal sleeve, and put the kettle in the top.

Solar Cooking References:

www.solarcooking.org

Capturing Heat booklets One and Two, by Dean Still et al, Aprovecho Research Center. (www.aprovecho.net)

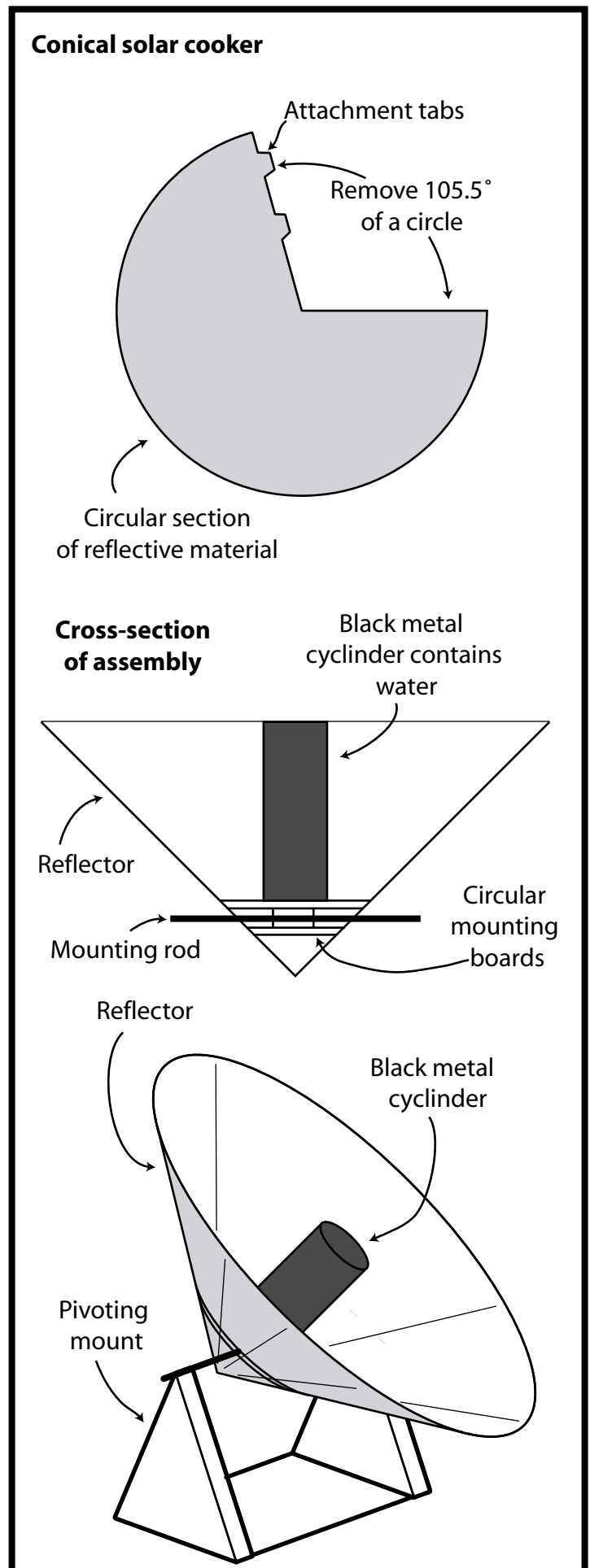

Biodigested Methane

Methane produced by decomposition in a chamber may be a suitable source of cooking fuel for some people. Essentially, manure, straw, and other organic materials with a high energy content are allowed to decompose under controlled circumstances. It's like composting, but without air.

This may be a good option for people who have limited access to firewood, but plenty of biomass.

The subject is too extensive to cover in this excerpt booklet, although it will eventually be covered in the full book.

Cooking Notes

There are a number of improvised cooking measures that aren't covered here, largely because of their dependence on petroleum-derived fuels. However, those options can be excellent temporary or emergency measures. Semi-solid fuels like paraffin, gelled alcohol or "Sterno" cans are safe and easy to use, although they don't generally burn as hot as other sources. You can find gelled, spill-proof fuels in camping or hardware stores, sometimes sold as "Canned Heat," or "Warming Gel," and some "environmentally friendly" products are made from sugar cane by-products. Liquid fuels like denatured alcohols or methyl hydrate can be used relatively safely in improvised stoves of a different type than here. You can use a simple shallow cup with a small amount of alcohol for quick burns, or a "plumber's stove," a can filled with cotton balls and alcohol. Liquid fuels like kerosene and gasoline *can* be used for fuel, but are volatile and difficult to use safely, since they can explode, and produce dangerous gases in an enclosed area. For more info on alcohol burning improvised stoves, look at:

<http://home.comcast.net/~agmann/stove/Stoves.htm>

It is also possible to prepare most grains and seeds without cooking them by soaking and sprouting them. Once the grains sprout they can be eaten raw. All you need is dried seeds, clean water, and a place to sprout the seeds. You put the seeds in a screen bag, a jar with a cloth over the mouth, or even a simple tray. Rinse the seeds in fresh water several times a day to keep them wet, and let the excess water drain off. In a few days the seeds will grow into sprouts. You can find out more about raw foods on the internet at websites like www.living-foods.com.

Please remember that **many beans can not be eaten safely without cooking**, and that sprouting is only safe if **clean drinking water** is used.

Capturing Heat booklets One and Two, by Dean Still et al, Aprovecho Research Center.

The Aprovecho "Fish Camp" Stove book, by Dean Still.

The Aprovecho Research Center website is www.aprovecho.net. Check out their stove page at <http://aprovecho.net/at/atindex.htm>.

Fieldbook for Canadian Scouting, Boy Scouts of Canada, 1986

The Journey to Forever Woodstove page:

http://journeytoforever.org/at_woodfire.html

The Home-Made Stove Archives, at:

<http://wings.interfree.it/html/main.html>

The extensive Renewable Energy Policy Project's Biomass Cooking Stoves page:

<http://www.repp.org/discussiongroups/resources/stoves/>

Quick Lighting and Heat

Lighting

Oil Lamp

The oil lamp is a very old form of lighting. The original oil lamps could be as simple as a cup or bowl filled partially with oil, with a wick to soak up the oil. The wick can be as simple as a piece of twisted moss. More wicks mean more light.

You can use pottery to make more complex shapes. The

general historical shape was much like a tea kettle, with a cotton, hemp, or other fibrous wick coming out the “spout”. The oil was poured in through the top. A saucer can be placed underneath to catch drips. All sorts of oil and fat are used.

You can also make a relatively safe improvised oil lamp like the one shown, derived from a design in Cresson Kearney’s *Nuclear War Survival Skills* (available online at: <http://www.oism.org/nwss/>).

Some sources suggest that olive oil and sunflower oil are the best vegetable oils for lamps, and corn oil is the worst.

Candles

For a long time, Europeans made tallow candles for their lighting. Tallow is simply rendered animal fat (fat with meat and other impurities removed by melting and straining). To render fat, the fatty animal tissue is boiled, and then cooled. A layer of fat forms on the surface of the water, which is scooped off and used for fuel. To remove all impurities, you may need to boil the fat/water mixture, strain it and then boil again repeatedly. After the mixture has been boiled, let it sit and cool. If you can get it cold enough, the fat will solidify and you can remove it in a block, and pick off any remaining meat from the bottom. Keep in mind that overheated fat may catch fire. Watch the rendering fat at all times, do not overheat, and keep a tight-fitting lid nearby to contain and extinguish the fire in an emergency.

Then, wicks are dipped in and out of a heated vat of tallow. Historically, this was smelly, unpleasant, and difficult. It could take 50 coats to make a decent-sized candle. Molds are easier, but more expensive.

Compared to modern paraffin (petroleum derived) candles, tallow candles smell bad, sputter and drip, produce sooty smoke, don’t burn for very long and melt easily at a low temperature (around 27°C or 80°F).

European colonists in North America found that bayberry or wax myrtle could be boiled to obtain wax, which had a preferable smell and could be added to the mix. Adding wild ginger and other spices also help.

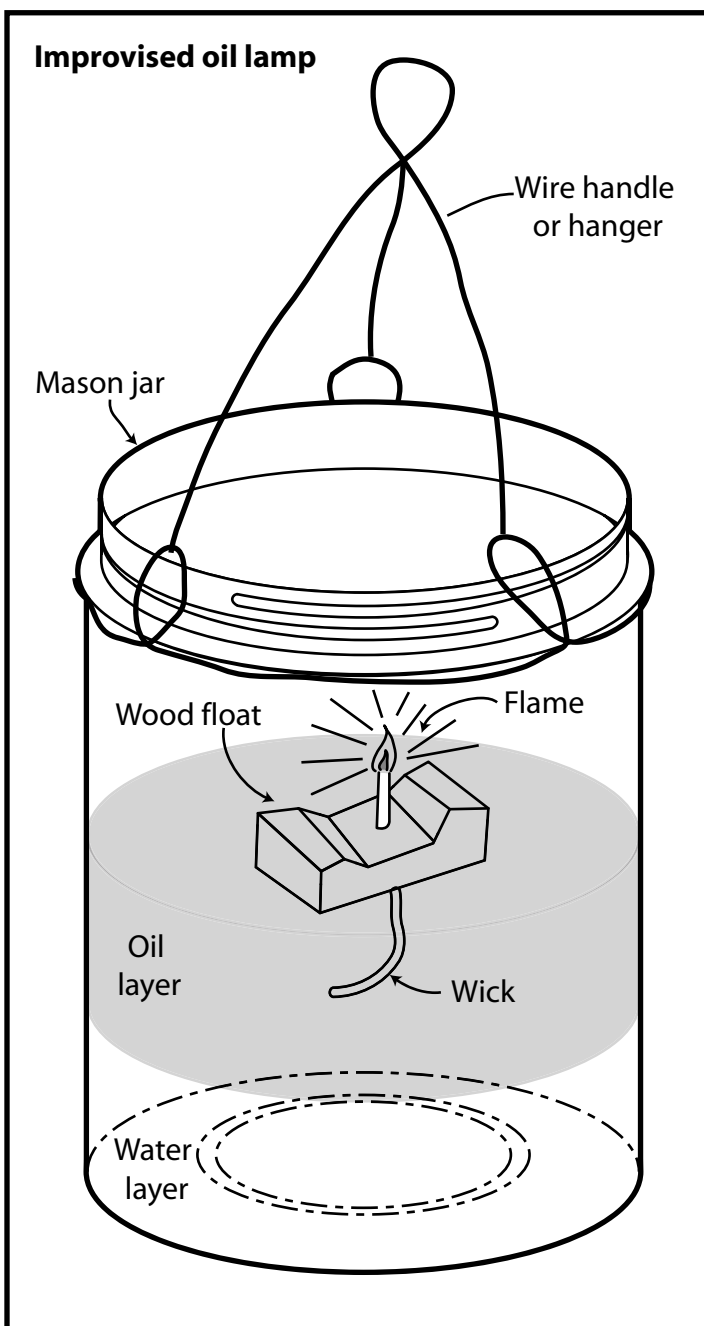

Beeswax candles are preferable in smell and longevity, but it is difficult to get large amounts of wax.

To get larger amounts of lighting you can put a number of candles in the dirt in a flowerpot, with a reflector on one side. A plastic flowerpot is lighter, but also more likely to melt or burn if the flame touches it.

Rush Light

Another option for lighting is the “rush light.” Rushes are picked, and the husks removed to leave the soft inner pith, which is dipped in melted fat. The rush lights burn very quickly.

Buddy Burner

The “Buddy Burner” is a simple improvised candle or stove, which can be used for lighting or for heat. The housing is a tuna can or similar container, with a cardboard spiral inside. Melted paraffin, or other fat, is poured in to saturate the cardboard. Once it is burning, more fat or wax can be put on top, which will then melt and burn as well. Place this burner on the ground or on a hot-pad, since the container will get quite hot when the contents are mostly burned away. Placing a wick in the centre may help it to get started. This is an excellent way to burn up the ends or drippings of other candles without having to make whole new candles.

Reflectors

In all of these cases, reflectors can be used to direct more usable light onto the desired area. Reflectors don't necessarily have to be shiny or mirrored, only light-coloured. Reflectors are also a good, simple way of getting more light indoors. At my home in the winter, sunlight reflects off of the white snow, and then up through the windows and off the white ceiling, and very deep into the house. During the day in winter, it is just as bright as it is in the summer, without any source of artificial light.

Improvisation Exercises

Assuming you live in a house, do you need to use artificial lighting in your house during the day? If you were making candles for all lighting yourself, you would probably want to save energy by only using them at night. Can you set up your workspace, position reflectors or paint surfaces white, so that you don't need to use artifi-

cial light indoors during the day?

Can you improvise an oil lamp or candle out of materials that you can find in your home? What oils do you find work best? Would these oils be more valuable for food and cooking or for lighting? What materials work best for the wick? Is the smoke produced excessive or sooty? How can changing the wick or configuration improve those properties? What works well as a reflector? Experiment and have fun. Let us know what you find out.

As the culmination of these exercises, try taping all of the lightswitches in your house in the “off” position for a week. Use only reflected sunlight during the day, and only home-produced candles or oil lamps at night. How does this change your daily routine? Are there some tasks which you can only do during the day? Do you go to bed and get up earlier? Does it affect how you feel?

Caution: Please do not burn yourself or your house down while doing this. Candles or oil lamps should not be left burning unattended. Not only is it dangerous, but it's a waste of wax, oil, and your working energy.

Lighting Notes

Obviously, for most cases a flashlight would be safer and simpler, although not as long lasting in some cases. You can buy flashlights that charge by solar power, cranking or shaking, which are suitable for off-the-grid use. You can also make a fairly simple improvised electrical system out of car parts and scavenged household electronics, but that is an extensive topic for later writings.

Heating

We'll look extensively at this topic in writings on shelter.

In the mean time, though, you can use a *Dona Justa* or other efficient, improvised stove to heat your house. You can replace a window with a metal sheet, and run the stovepipe through it. However, if you burn anything larger than candles in your house, make sure to provide adequate ventilation. Try opening a window a crack on each side of the room, to avoid carbon monoxide poisoning. If you feel drowsy or have a headache, your body could be warning you of inadequate ventilation.

When using a fire, someone should always stay awake to make sure that it does not get out of hand, and that ventilation is adequate. Keep fire-fighting materials at hand, such as buckets of water or sand, baking soda, salt, a heavy blanket or tarp, or a chemical fire extinguisher.

Wear as much extra clothing as you need, and use extra blankets on your bed. Sleep close to other people and animals.

You can also make “thermal curtains”, which are essentially thick blankets, to put over your windows. You can also put layers of plastic over your windows to have the same effect. This will reduce heat loss, especially at night. Try to find drafts and block them, but do *not* make your house air tight. You want to be able to regulate ventilation, but you need air to circulate to remove carbon dioxide and other gases that might build up and become toxic.

Choose one room to concentrate the heat in, and close off the others. You can use partitions made out of blankets, drapes, cardboard, plywood or several layers of plastic sheeting. Choose a room on the side of the house away from prevailing wind, and one that is well insulated and has few or small windows. An interior bathroom may work well, unless you are using a stove, in which case you need a window to vent. A basement may be a good choice, since the earth is somewhat warmer than the surface air in winter, and has an insulating effect.

If you do live in a cold climate, and have to go without a heated house, you will gradually get used to it. The colder temperatures will become more comfortable. (After spending six weeks in tents on a mountainside late one winter, “room temperature” in houses started to feel scorching hot to me.)

In cold weather, make sure that you get enough water. Cold air is relatively dry, and you may not be aware that you are becoming dehydrated. If you are slightly dehydrated, your metabolism slows significantly.

You will probably need to eat more fat and calories as well, to ensure that your body has enough energy to keep itself warm.

Heating Notes

“Staying Warm in an Unheated House: Coping With a Power Outage in Winter,” University of Wisconsin Extension, 1996.

The Encyclopedia of Country Living, by Carla Emery.

Rubbish

Garbage and Recycling Collection

If you're in a rural area you may already have to get your own garbage and recyclables to the dump. But if you're like most people in the industrialized world, you're an urban dweller, and your garbage is picked up and taken away on a regular basis.

There are a lot of events that could disrupt that service. Industrial and economic collapse are obviously big ones, but strikes are not uncommon either. A long-term collapse in garbage collection would probably happen at the same time as a collapse in the consumption of disposable items, so this may not be much of a problem for some people. However, it's still relevant for the present time.

I actually have pretty mixed feelings about recycling as it is. One major problem is the fact that some people who recycle think that it is all that they could be expected to do: "I recycle, I help the environment, what more can you ask of me?" However, recycling barely diminishes the negative effects of industrial civilization. In fact, by providing a cheap source of refined metals, pulp, glass and plastics, recycling increases the efficiency and the longevity of civilization.

I think one of the primary characteristics of civilization is its tendency to extract and centralize resources. Centralized resources can be controlled, defended and manipulated more easily than distributed resources. The centralization is necessary in a machine culture—an industrial society—because high concentrations of resources are required to feed the ravenous machines. Distributed resources are fine for living creatures, because living creatures adapt to the conditions wherever they are.

Resources are redistributed in a controlled way through consumables. Many modern consumables are intentionally designed to be non-reusable, and to have disposable packaging to increase consumption. These resources are recentralized for civilization by recycling collection. This provides an extra supply of raw resources which can be used. The paper can be recycled into propaganda to rationalize the actions and beliefs of those in power. The

steel can be recycled into more machines, or made along with glass into containers to bring the products of global industrial agriculture to the homes of "consumers".

Is it really in our best interests to make anything easier for civilization than it needs to be? Do we really want to give it some of the few resources that we have under our control? These are challenging questions.

In any case, you have plenty of options to reuse materials that you would otherwise recycle industrially. This is a topic that will be covered in depth in later writings, under the subject of what I like to call "Remnant Resources"—resources that industrial society produced, but can not be produced by ecological and egalitarian communities. These are resources that are around for now, but will eventually run out because of use and degradation. In the mean time, here are some suggestions for how to handle different materials:

Organics

Kitchen scraps and other organic materials can be composted to add to your garden, or simply returned to the earth.

Plastics

Plastic jars and bottles can, of course, be reused as containers. As described in the Solar Disinfection and Water Storage sections, PETE and HDPE containers are preferred for food and water storage.

Plastic pop bottles, the large ones in particular, can be used as irrigation systems for your garden. Tammy T. suggests poking about twenty small holes in a pop bottle and burying it so that only the mouth is visible. You can bury them every few feet or so, depending on your soil and climate. Then you can fill them up (with a funnel if it helps) every few days, and the water will gradually trickle directly to the roots of the plants.

Unfortunately, Tammy notes, plastic milk jugs are not well suited for this or other long-term storage uses. They tend to become cracked and brittle in about six months.

Plastic shopping bags are present in incredible numbers, and if allowed to blow into the wild they are a menace.

However, they can be very useful for carrying things while they are intact. They can also be cut down the sides and included in shelter or clothing as improvised water-proofing or vapour barrier. Melting shopping bags with a flame will give an improvised hot glue, and can also be used as improvised caulking. For instance, they can be used to seal the openings around pipes in the barrel of the slow sand filter described in the water section. They can also be made into cordage.

However, if there is any other option, styrofoam and plastics should not be burned. In many cases, their burning releases a variety of toxic chemicals, including dioxin. So, while burning plastic rubbish is a way of getting rid of plastic where you are, it simply spreads the pollution into the air and water, where it can not be contained. If certain plastics are no longer useful, put them in a dry, out-of-the-way place and store them indefinitely. (Better but more complex solutions than this will be discussed in later writings.) One situation where it may be appropriate to incinerate plastics is to dispose of very contagious medical waste. However, *never burn plastic inside or in a poorly ventilated area*, as the gases produced are harmful.

Metal

Steel cans can be reused for any number of purposes. They can be made into cooking stoves, pots, drinking and storage containers. If you have no aluminum foil, you can cut the tops off of two cans, place cut vegetables inside of them, jam them together, and cook the container in the fire. The non-enameled types may rust over time, depending on storage conditions. However, aluminum cans, including most beer cans, will not rust. Thus they are good for storing water. Slit down the side and flattened out, they can be used as waterproof, long-lasting improvised shingles.

Glass

Glass jars and bottles can be used, of course, as containers, and will last a long time. Thick glass can be used for knapping (chipping to create arrow-heads or other tools).

Paper and Cardboard

Paper and cardboard can be used for fuel for your stove. They can also be used for mulching and composting, but

use only papers printed with black and white, soy-based inks. Colour inks and other types of ink include toxins that you don't want to introduce to the soil. Layers of corrugated cardboard can make a decent insulation, as do layers of newspaper stuffed into your clothing, though both are flammable.

Polycoat

Tetrapaks and other modern packaging often consists of multiple layers of plastic, foil, and paper, called "polycoat". This can be difficult to deal with. You are best off trying to reuse the containers. However, many people I know simply burn off the plastic and paper, and fish the foil out of the ashes.

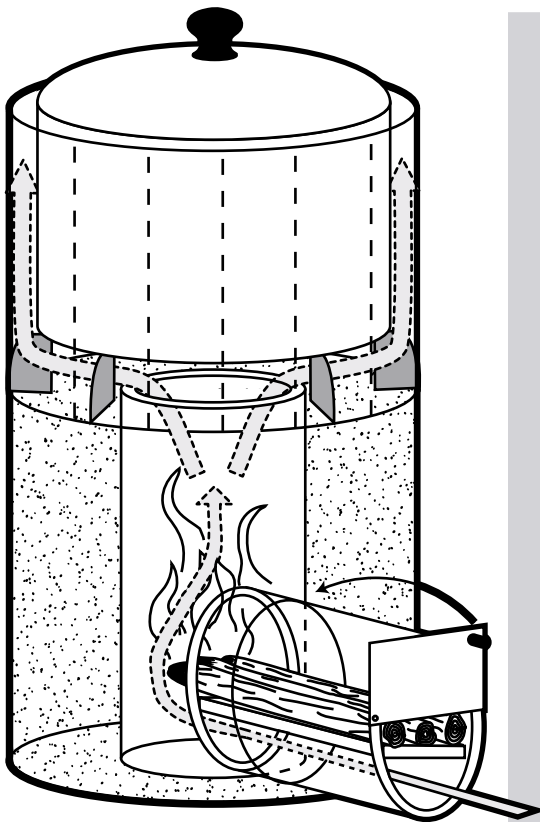

Winiarski Rocket Stove (page 30)

“This booklet is an excerpt from a larger book project which is in the works, called “In the Wake: A Collective Manual-in-Progress for Outliving Civilization.” This project, and my writings and life in general, are based on the premise that industrial civilization is destroying the world and exploiting and murdering the inhabitants of the world.”

“Many of us are very busy with making a living, taking care of ourselves and each other, doing activism and so on. We can’t all spend as much time as we’d like camping in the forest, growing gardens, learning improvised wilderness first aid, or learning other skills for collapse. And the likely timeline for collapse is staggeringly short. We can expect massive disruptions of global industrial and transportation systems starting between 2005 and 2010. One of the reasons that I am writing this is for it to be a ‘crash course’ for the crash, a way of quickly introducing a variety of important skills and technologies to people who aren’t familiar with them, as well as creating a reference and resource for those who are.”
(from the introduction)

Inside you’ll find concise, illustrated information on improvised tools and methods to meet needs for:

Water (page 1)

Latrines and Greywater (page 15)

Cool Food Storage (page 22)

Cooking (page 27)

Quick Lighting and Heat (page 39)

Dealing with Rubbish (page 42)