

POWER TOOLS. PLATE 27

SPRING SWAGES

PLATE 27 shows a collection of useful spring tools. FIG. 1 illustrates a pair of spring swages which are used for rounding forgings to the required size. Swages for use, as in FIG. 1, should be made with the inside corners having plenty of radius, as shown. This prevents the material from sticking when revolving.

FIG. 2 shows a pair of double eye swages which really act as stamps to form double eye bosses, as shown in FIG. 3.

FIG. 4 shows a pair of middle boss swages used for stamping a boss in the middle of a bar, as shown in FIG. 5.

FIG. 6 shows a pair of eye bolt swages, used for stamping a boss with a round shank attached, as shown in FIG. 7.

FIG. 8 shows a pair of side boss swages used for stamping bosses on one side, as shown in FIG. 9.

FIG. 10 shows the method of fixing the handles in the tools, as previously described on PLATE 26.

SPRING SWAGES. PLATE 87

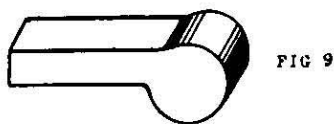
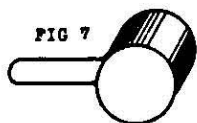
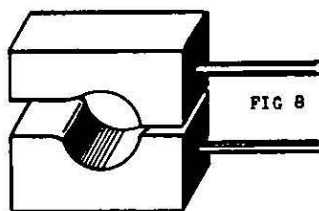
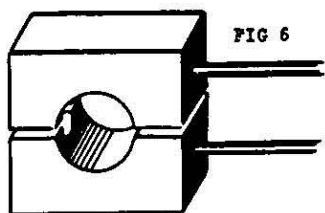
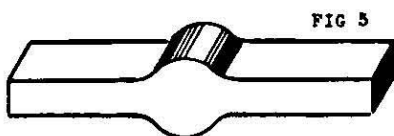
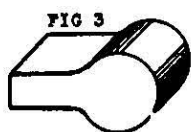
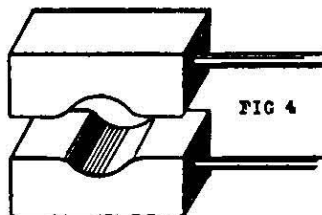
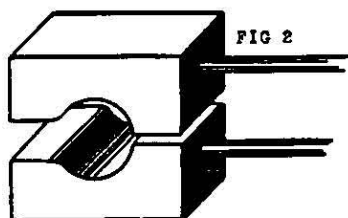
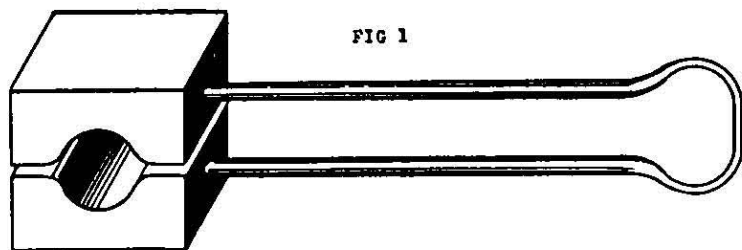

FIG 10



POWER TOOLS. PLATE 28

TAPERED TOOLS

PLATE 28 illustrates tapered tools and their uses. These tools are very essential in the smithy.

FIG. 1 shows a pair of tapered sets. These should be made to various angles, to enable the smith to select the required pair for any given forging that may need tapering. Should a pair of sets be required which are not in stock and it is found necessary to have them made, FIG. 2 shows the method to adopt. Mark the given taper of the required forging on a plate and make the sets to same. FIG. 3 shows the bar drawn down to the given set. Finish by cutting off at the dotted lines. These top and bottom sets are used when tapering between bosses, as shown in FIG. 4.

FIG. 5 shows a single tapered set.

In FIGS. 6 and 7 the bar is drawn down, as in FIG. 3, with the exception that in this example the bar is fullered and drawn down. The ends are then bent down, as shown in FIG. 5.

FIG. 8 illustrates the tapered set in use.

FIG. 9 shows a round tapered mandril for enlarging round holes.

FIG. 10 shows an oval mandril used for shaping the eye of a hand hammer.

FIG. 11 shows a square tapered mandril for enlarging square holes.

FIG. 12 shows a hexagon mandril used for shaping spanner jaws.

TAPERED TOOLS. PLATE 28

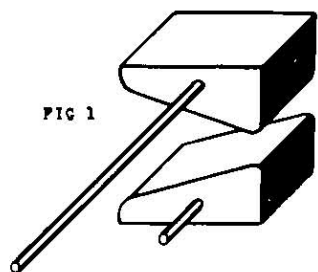

FIG 1

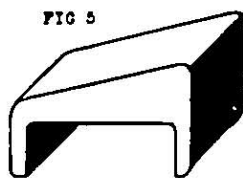

FIG 5

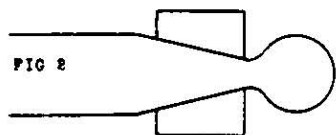

FIG 2

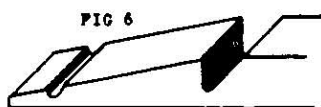

FIG 6



FIG 3

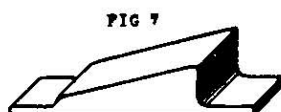

FIG 7

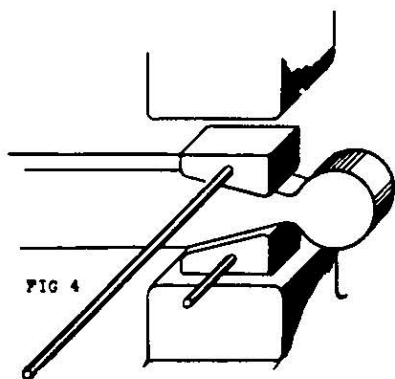

FIG 4

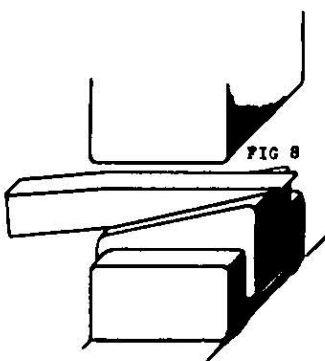

FIG 8



FIG 9



FIG 10



FIG 11



FIG 12

POWER TOOLS. PLATE 29

PUNCH AND DIE

PLATE 29 illustrates a very useful tool for punching holes in flat bars.

FIG. 1 shows the formation of the die. The bottom hole acts as the die and the top hole as a guide for the punch.

FIG. 2 illustrates the first operation when making a die. Draw down a 3-inch by $1\frac{1}{2}$ -inch bar to 3-inch by $\frac{3}{8}$ -inch, then fuller between, as shown in FIG. 3, and draw down, as shown in FIG. 4. Drill a hole in each end and taper the bottom hole for clearance. Finish by bending, as in FIG. 1.

FIG. 5 illustrates the shape of the punch made of hardened steel.

FIG. 6 shows the punch and die in use.

FIG. 7 gives a sectional view of punch and die.

PUNCH AND DIE.

PLATE 29

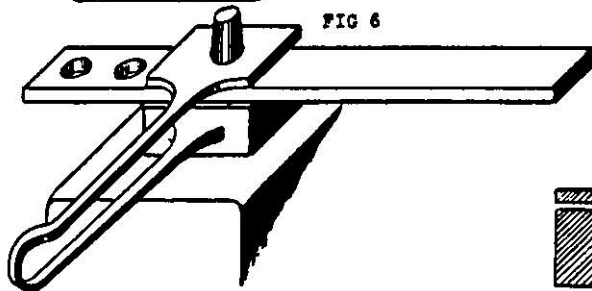
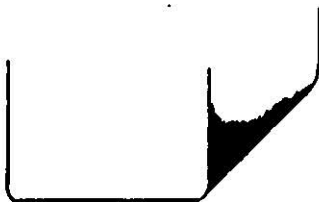
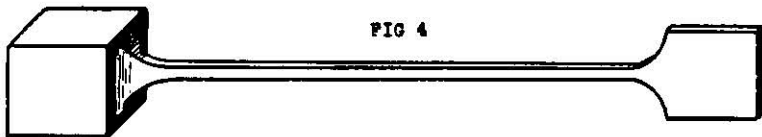
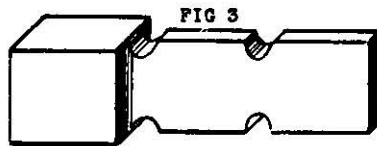
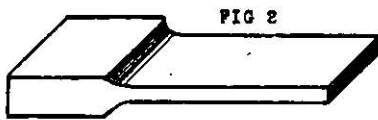
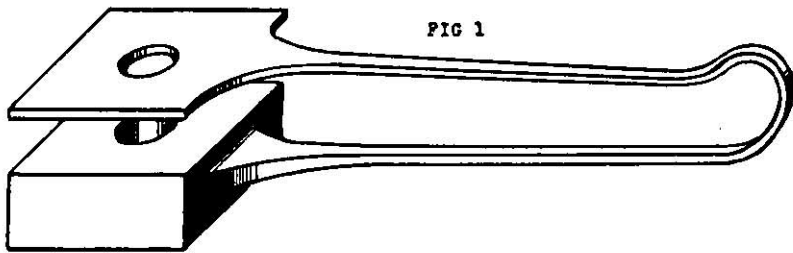

POWER TOOLS. PLATE 30

COTTER DIE

PLATE 30: FIG. 1 illustrates a very useful tool used for punching cotter holes.

FIGS. 2, 3, 4 show the method of making a cotter die for punching a 1-inch by $\frac{1}{4}$ -inch cotter hole. Commence by making a block of mild steel 3 ins. square, then using a tapered cotter punch, the cotter hole is punched out, FIG. 2. Next hammer a tapered mandril in to form the cotter hole, FIG. 3. FIG. 4 shows the final operation. A hole $1\frac{1}{8}$ in. in diameter is drilled in the block, to allow a 1-inch diameter bar, when hot, to enter.

FIG. 5 shows the shape of the cotter punch used when punching under the hammer.

FIG. 6 shows the punch ready to be hammered through the bar ; the result is shown in FIG. 7.

If a steam hammer is not available, an alternate method is shown in FIGS. 8, 9, 10.

FIG. 8 shows a punch being used to punch the cotter hole into the bar.

FIG. 9 shows a piece of steel being used to keep the hole in shape while swaging the bar, as in FIG. 10.

COTTER DIE.

PLATE 30

FIG 1

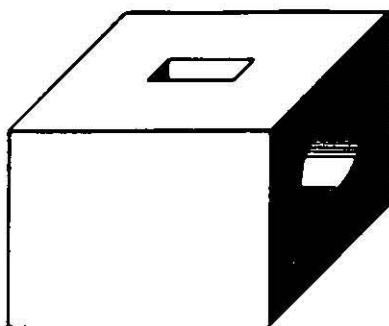

FIG 2

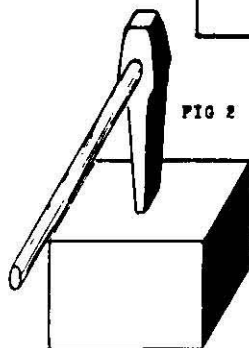

FIG 3

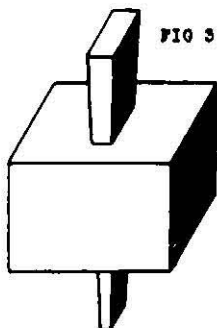

FIG 4

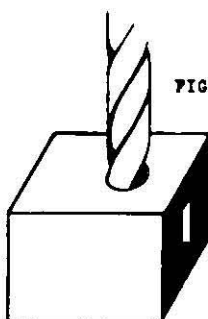

FIG 5



FIG 6

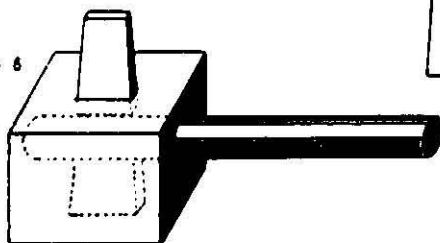

FIG 7

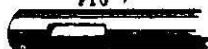

FIG 8

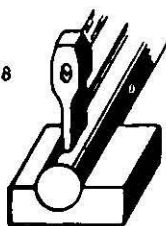

FIG 9



FIG 10



POWER TOOLS. PLATE 31
HANDLES

PLATE 31 illustrates methods of handling heaving forgings by other means than tongs.

FIG. 1 illustrates an appliance known as a portabar which is clamped to a forging. To make a portabar weld a piece of angle bar to a round bar, as shown in FIG. 2.

FIG. 3 shows a pair of handles which act as a pair of clams to clamp the portabar, when forging. In this case the striker acts in conjunction with the smith, by putting his weight on the portabar to enable the smith to turn the forging as required.

FIG. 4 shows another design of handles.

HANDLES.

PLATE 31

FIG 1

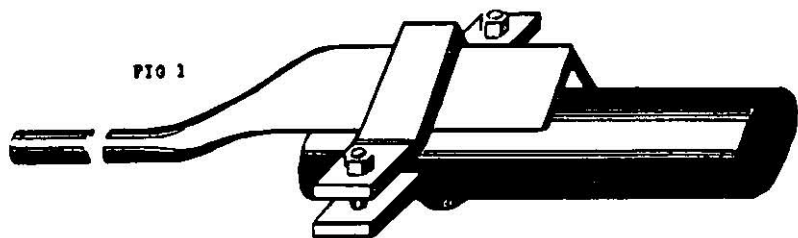

FIG 2



FIG 3

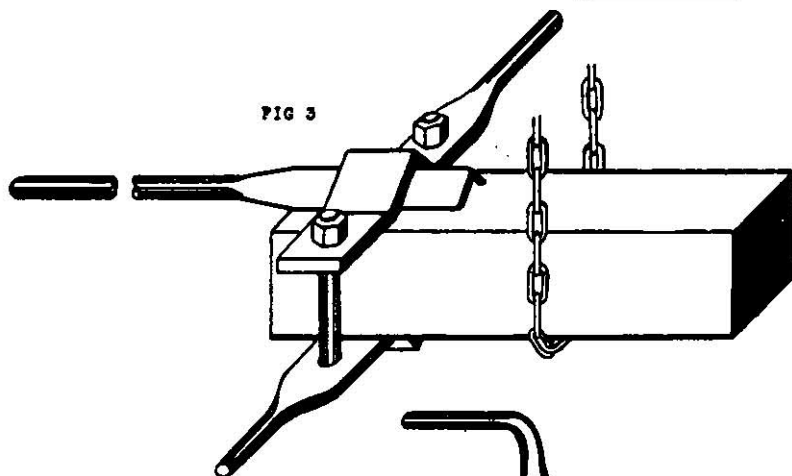
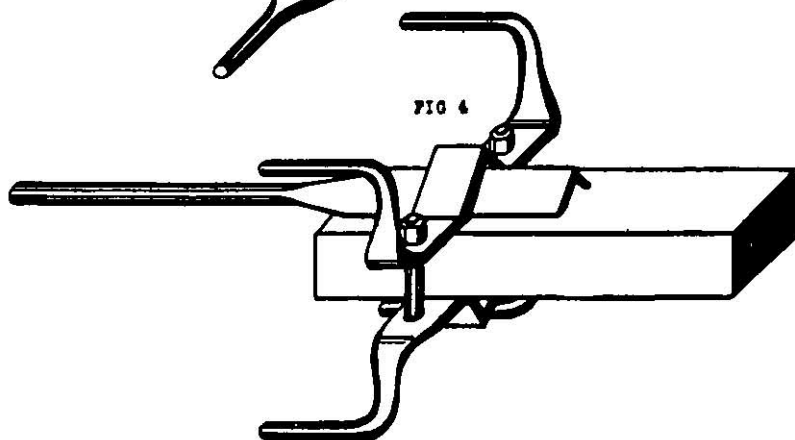

FIG 4



POWER TOOLS. PLATE 32

CRANE

PLATE 32 illustrates a crane supporting a forging. This apparatus is invaluable in a shop where heavy forgings are handled on the anvil and under the steam hammer. When erecting a crane in the smithy, select a position which will allow the jib to reach the fire, anvil, and steam hammer. The crane illustrated shows the jib reaching over the top of the steam hammer. It can therefore cope with any forging close to the hammer.

The following dimensions will give an idea of the material required to make a crane.

The shaft or pivot which supports the jib is $2\frac{1}{2}$ ins. diameter, fixed into double eyes which are riveted or bolted to a girder, as shown.

The jib is 3 ins. by 1 in. and the tie rod $1\frac{1}{4}$ in. diameter.

On the jib two pulley wheels are held together by two plates. These support a right- and left-hand screw adjustment which in turn supports a snatch block and chain used for turning the forging.

CRANE.

PLATE 32

FIG 1

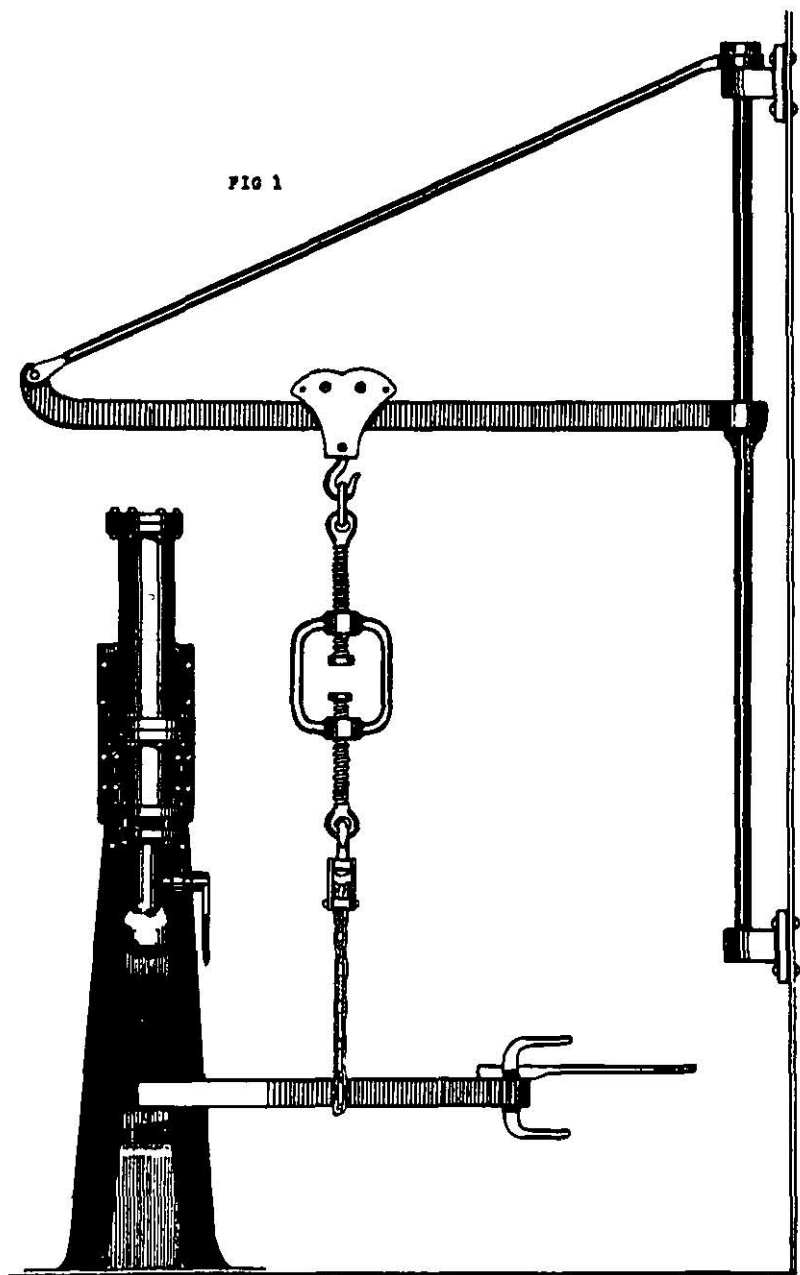

ESTIMATION OF LENGTHS OF MATERIAL

After acquainting himself with the various tools and their uses, as illustrated on the preceding plates, the young smith may find this chapter, on the estimation of lengths, of some real service to him. A great amount of unnecessary work and worry have resulted where smiths have not taken the trouble to do a simple calculation, but have endeavoured to arrive at a given result purely by guesswork.

A few examples are given here for obtaining the weight per ft. of steel bars.

To find the weight per ft. of square, round, and flat bars.

Formula : Multiply the width in eighths (inches) by the thickness in eighths (inches) and divide by 19 for square and 24 for round bars.

Examples : 6-inch square bar and 6-inch diameter bar.

$$\begin{array}{r}
 \text{6 ins. sq. 6 sq.} \\
 \begin{array}{r}
 8 \\
 \hline
 48 \\
 \hline
 48 \\
 \hline
 384 \\
 \hline
 192 \\
 \hline
 19)2304 \\
 \hline
 121 \cdot 2 \text{ lb. per ft.}
 \end{array}
 \end{array}$$

$$\begin{array}{r}
 \text{6 ins. dia. 6 dia.} \\
 \begin{array}{r}
 8 \\
 \hline
 48 \\
 \hline
 48 \\
 \hline
 384 \\
 \hline
 192 \\
 \hline
 24)2304 \\
 \hline
 96 \text{ lb. per ft.}
 \end{array}
 \end{array}$$

ESTIMATION OF LENGTHS OF MATERIAL

To find the weight of flat bars adopt the same method as that for finding the weight of square bars.

Example :

$$\begin{array}{r}
 7\frac{1}{2} \text{ ins.} \times 3\frac{1}{4} \text{ ins. sq. bar} \\
 \frac{8}{60} \quad \times \quad \frac{8}{26} \\
 \hline
 26 \\
 \hline
 360 \\
 \hline
 120 \\
 \hline
 19)1560 \\
 \hline
 82 \cdot 1 \text{ lb. per ft.}
 \end{array}$$

To find the weight per 1 in. of steel bars, multiply the width by the thickness and multiply the result by 2. Divide by 7 for square and by 9 for round bars.

Example :

$ \begin{array}{r} 6 \text{ ins. sq.} \\ \frac{6}{36} \\ \frac{2}{7} \overline{)72} \\ \hline 10 \cdot 2 \text{ lb. per inch.} \end{array} $	$ \begin{array}{r} 6 \text{ ins. dia.} \\ \frac{6}{36} \\ \frac{2}{9} \overline{)72} \\ \hline 8 \text{ lb. per inch.} \end{array} $
--	--

Examples in fractions : $7\frac{1}{2}$ ins. by $3\frac{1}{4}$ ins. sq. bar.

$$7\frac{1}{2} \text{ ins.} \times 3\frac{1}{4} \text{ ins.} \times 2 \div 7$$

$$\frac{15}{2} \times \frac{13}{4} \times \frac{2}{7} = \frac{195}{28} = 6 \cdot 96 \text{ lb. per inch.}$$

It must be borne in mind that these methods give approximate results only, but from experience they have been found to give satisfaction.

The usefulness of arriving at these weights may not at first be apparent to the young smith, but it will be seen in examples to follow that where the weight per ft. of a bar to be forged is known and where the weight per ft. of the bar from which it is to be made down is known, a simple deduction will quickly guide the smith as to the correct length of material he requires.

ESTIMATION OF LENGTHS OF MATERIAL.
PLATE 33

FORGING

PLATE 33 gives a few examples of material to be drawn down. Find the weight of each section by following the instructions given, then from these weights the length to be drawn down can easily be found.

From the method of calculating lengths of forgings given in preceding chapters, an allowance in weight is given in practically all cases to allow for a certain amount of depreciation in the material when it is heated. The correct amount to allow will only be found with practice. To know the weight required is the chief help, but the allowance must not be ignored, otherwise the smith may find himself short of material on completion.

FIG. 1 shows 18 ins. of 1 in. diameter drawn down from 2 ins. diameter.

FIG. 2 shows the 2-inch diameter bar fullered $4\frac{1}{2}$ ins. from the end required to be drawn down.

FIG. 3 shows 18 ins. of 1 in. square drawn down from 2 ins. square.

FIG. 4 shows the 2-inch square bar fullered $4\frac{1}{2}$ ins. from the end required to be drawn down.

FIG. 5 shows 15 ins. of $1\frac{1}{2}$ in. square drawn down from $3\frac{3}{4}$ ins. diameter.

FIG. 6 shows the $3\frac{3}{4}$ -inch diameter bar fullered $3\frac{1}{4}$ ins. from the end required to be drawn down.

FIG. 7 shows 20 ins. of $1\frac{1}{2}$ in. diameter tapered to $\frac{3}{4}$ in. diameter drawn down from 3-inch diameter bar.

FIG. 8 shows the 3-inch diameter bar fullered 3 ins. from the end required to be drawn down.

FORGINGS.

PLATE 38



FIG 2

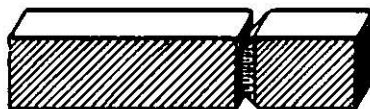
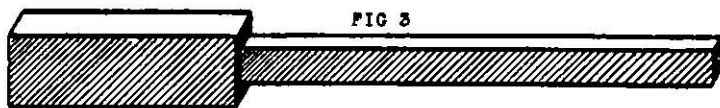

FIG 4

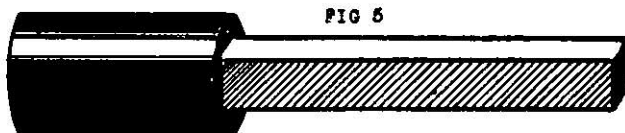

FIG 6

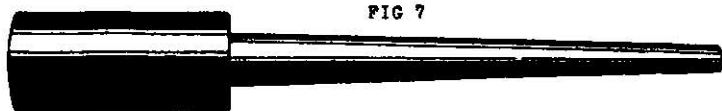

FIG 8

ESTIMATION OF LENGTHS OF MATERIAL.
PLATE 34

FORGINGS

PLATE 34 gives a few examples of jumping small sections into larger sections.

FIG. 1 illustrates a blank flange 6 ins. by 1 in. made from a 3-inch diameter bar. To obtain the length of 3-inch diameter bar required, calculate as follows:—

Method.—To find the weight of 6-incl. diameter bar 1 in. thick. Square the diameter, multiply by 2 and divide by 9, viz. : $6 \times 6 \times 2 \div 9 = 8$ lb. per inch.

Similarly find the weight of the 3-inch diameter bar :

$$3 \times 3 \times 2 \div 9 = 2 \text{ lb. per inch.}$$

$$8 \div 2 = 4 \text{ ins.}$$

FIG. 2 shows 4 ins. of 3-inch diameter bar which is required to make the blank flange 6 ins. diameter 1 in. thick.

FIG. 3 illustrates a forging 9 ins. diameter by $1\frac{1}{2}$ in. thick made from 4-inch diameter bar.

FIG. 4 shows $7\frac{3}{4}$ ins. of 4-inch diameter bar, the quantity required to make the forging 9 ins. diameter and $1\frac{1}{2}$ in. thick.

FIG. 5 illustrates a forging $7\frac{1}{2}$ ins. square by $1\frac{3}{4}$ in. made from a $4\frac{1}{2}$ -inch square bar.

FIG. 6 shows $4\frac{1}{2}$ ins. of $4\frac{1}{2}$ -inch square bar, the quantity required to make the $7\frac{1}{2}$ ins. by $1\frac{3}{4}$ in. forging.

FIG. 7 illustrates a wedge-shaped forging 10 ins. long by 4 ins. square at one end, made from a 4-inch square bar.

FIG. 8 shows 5 ins. of 4-inch square bar, the amount required to make the wedge-shaped forging 10 ins. long by 4 ins. square at one end.

FORGINGS.

PLATE 34

FIG 1

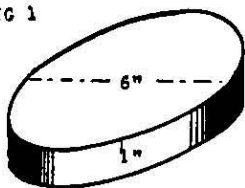

FIG 2

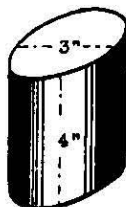

FIG 3

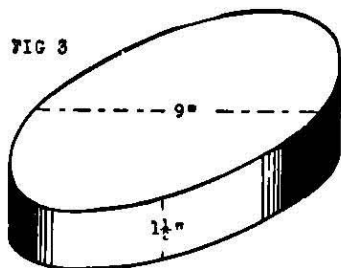

FIG 4

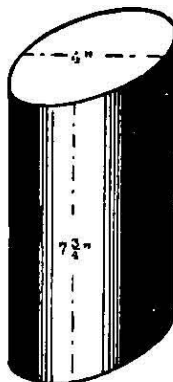

FIG 5

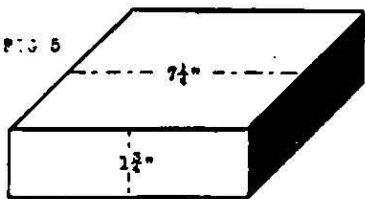

FIG 6

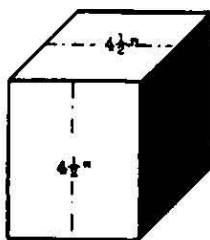

FIG 7

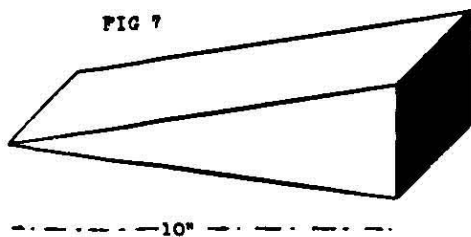
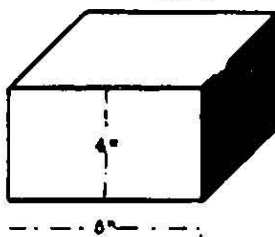

FIG 8



ESTIMATION OF LENGTHS OF MATERIAL.

PLATE 35

FORGING

PLATE 35: FIG. 1 shows 18 ins. of 4 ins. tapered to 2 ins. by 1 in. thick from a 4-inch square bar.

FIG. 2 shows the 4-inch square bar fullered $3\frac{3}{4}$ ins. from the end which is required to be drawn down.

To get the best results when drawing a forging down, take a little at a time. The method to adopt is given in FIG. 3.

FIG. 4 illustrates the finishing of the taper by using tapered sets under the steam hammer.

Note.—An easy method in calculating the weight of a tapered bar is by adding the largest and smallest widths of the tapered section together and dividing by 2, thus obtaining the mean width.

FORGING

PLATE 35

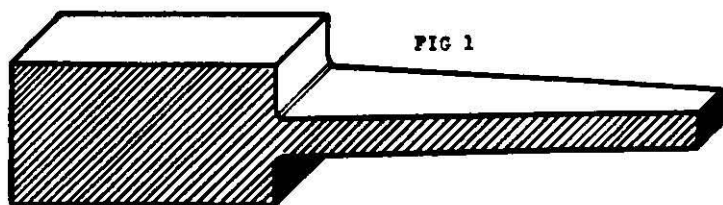

FIG 1

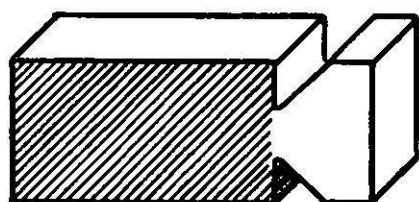

FIG 2

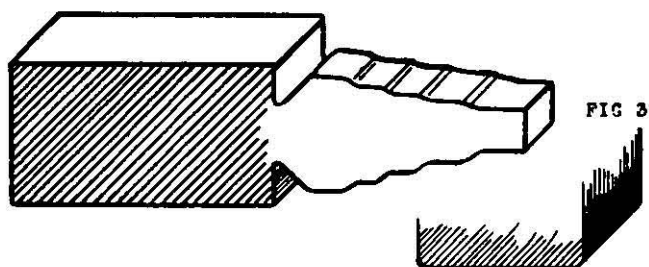

FIG 3

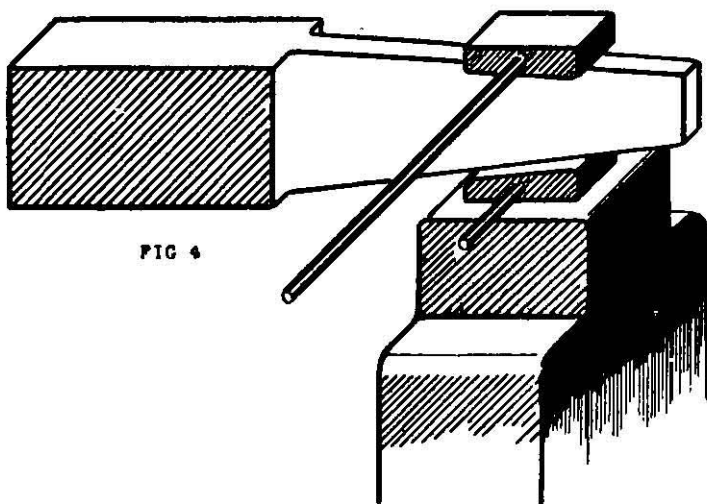

FIG 4