

ESTIMATION OF LENGTHS OF MATERIAL.
PLATE 36

LINK. SHACKLE. CLAMS.

PLATE 36 gives a few simple methods of obtaining lengths.

FIG. 1 shows a link with an overall length of 6 ins. and an inside width of 2 ins. The length of material required to make this link is 14 ins. (FIG. 2). Method of finding length: Add twice the overall length to the inside width.

FIG. 3 shows a shackle. Length from the centre of the holes to the inside of the shackle, 6 ins. Width between, 2 ins. The length of the shackle from centre to centre of the holes before bending is 14 ins. (FIG. 4). This length is found by adding twice the given length to the inside width.

FIG. 5 shows another shackle of a different shape, its length before bending being 16 ins. from centre to centre of the holes (FIG. 6). This length is found by adding twice the distance between the centre of the holes and the centre of the opposite side, as shown, to the inside diameter of the shackle.

FIG. 7 shows a pair of 12-inch clams. An easy method of obtaining the approximate length of material required to make the bend of a half clam, is by adding the given diameter to the radius, e.g. let the diameter be 12 ins. The radius is therefore 6 ins., giving the required length 18 ins. (FIG. 8).

Note.—These lengths are approximate, and are very suitable for shop practice.

LINK. SHACKLE. CLAMS.

PLATE 36

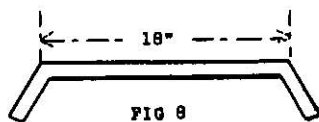
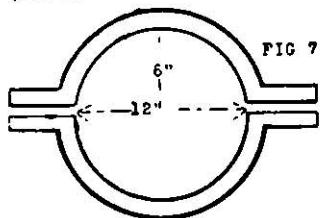
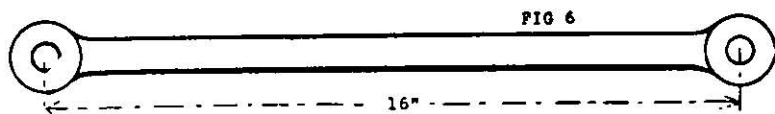
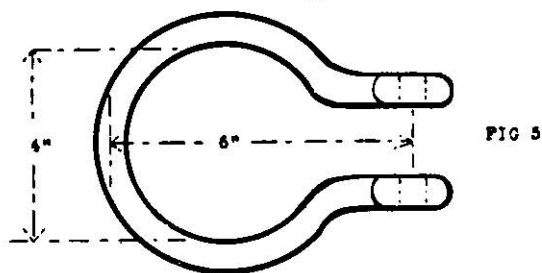
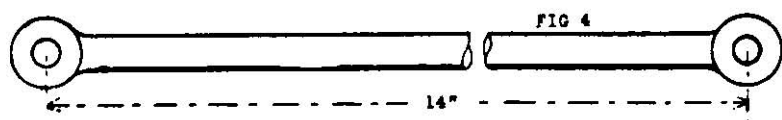
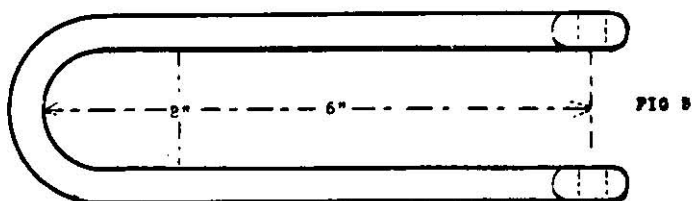
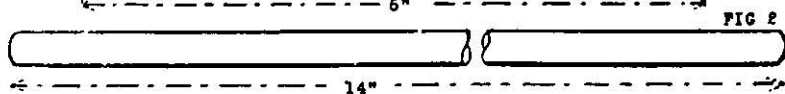
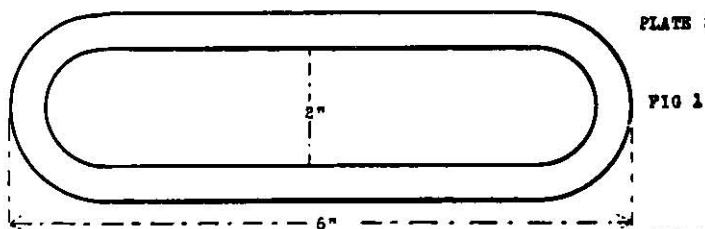

ESTIMATION OF LENGTHS OF MATERIAL.
PLATE 37

HOOP

PLATE 37: FIG. 1 illustrates a hoop which has an inside diameter of 12 ins. and made from 3-inch by 1-inch bar. The required length of material for making such hoops often presents itself as a difficulty to the smith.

A very useful rule to follow, and one often applied in shop practice is here given. To three times the inside diameter add three times the thickness and allow $\frac{1}{2}$ in. to every foot of the inside circumference. This rule, applied to the given hoop which is 12 ins., would be $40\frac{3}{4}$ ins. Applying the supposedly correct method (diameter by 3.1416 plus three times thickness and $\frac{1}{2}$ in. allowance for welding) to the above example, the length required would be $41\frac{1}{8}$ ins., the difference being $\frac{3}{8}$ in. The smith would do well to follow the former method, as it is easier to draw a hoop which is too small to the correct size, than to jump one which, on completion, is too large.

FIG. 2 shows a special tool for placing hoops on for welding.

FIG. 3 shows a method of bending a bar to form a hoop.

One method for rounding a hoop is by heating it all over, placing it on a cone, and hammering it to the required shape, as shown in FIG. 4.

HOOP.

PLATE 37

FIG 1

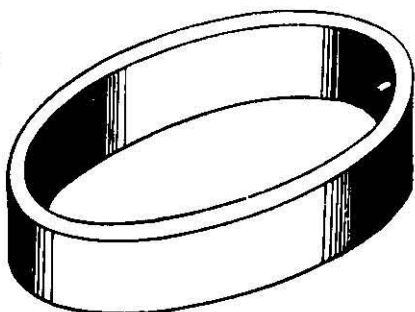

FIG 2

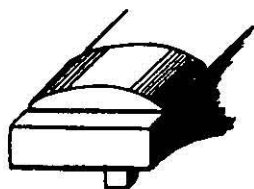

FIG 3

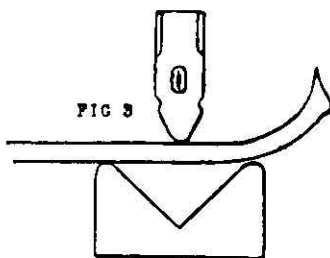
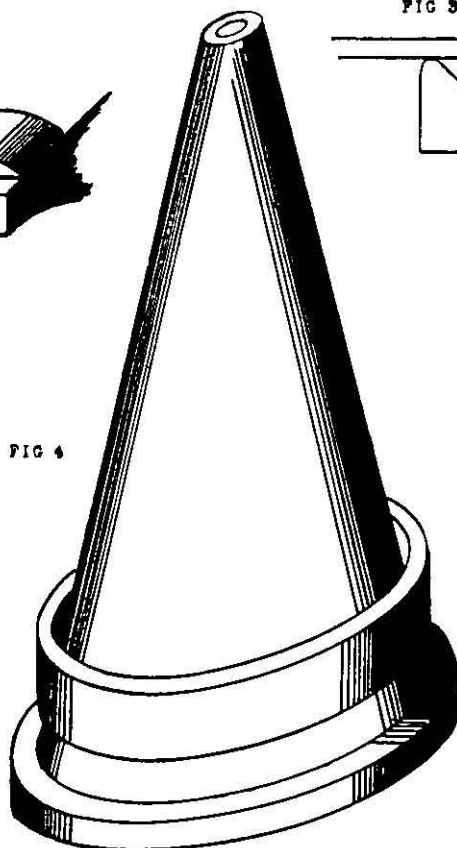

FIG 4



ESTIMATION OF LENGTHS OF MATERIAL.
PLATE 38

CONED HOOPS

PLATE 38: FIG. 1 shows a cone-shaped hoop, made from a 2-inch by $\frac{1}{2}$ -inch bar having a top inside diameter of 16 ins. and a bottom inside diameter of 18 ins.

The required length of the material (circumference) can be found by adding the two inside diameters together and dividing by 2 (mean diameter). The result (17) is then multiplied by 3.1416 which gives 53.4072 ins. To this figure should be added three times the thickness of the hoop ($1\frac{1}{2}$ in.) plus $\frac{1}{2}$ in. for welding, making the answer 55.4072.

FIG. 2 shows the bar cut to the required length.

FIG. 3 shows the same scarfed.

The smith should remember that when making cone-shaped hoops, the material must always be bent edgewise to a given radius.

FIG. 4 shows the method of obtaining the necessary radius before bending. Lay two parallel lines the width of the bar apart with a centre line running at right angles. On the parallel lines mark off from the centre line half the diameters of the hoop, i.e. 8 ins. and 9 ins. is shown. Draw two diagonal lines through these points to touch the centre line. This gives the centre point for the compasses to draw in the inner and outer circumferences as shown. Next bend the bar to the given radius.

FIG. 5 shows the bar cambered right for making the hoop.

CONED HOOP.

PLATE 38

FIG 1

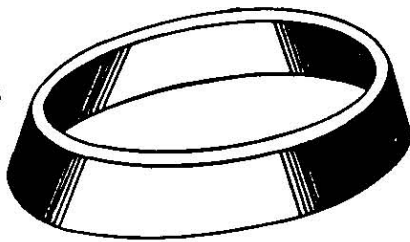

FIG 2



FIG 3

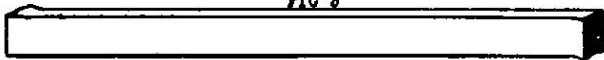

FIG 4

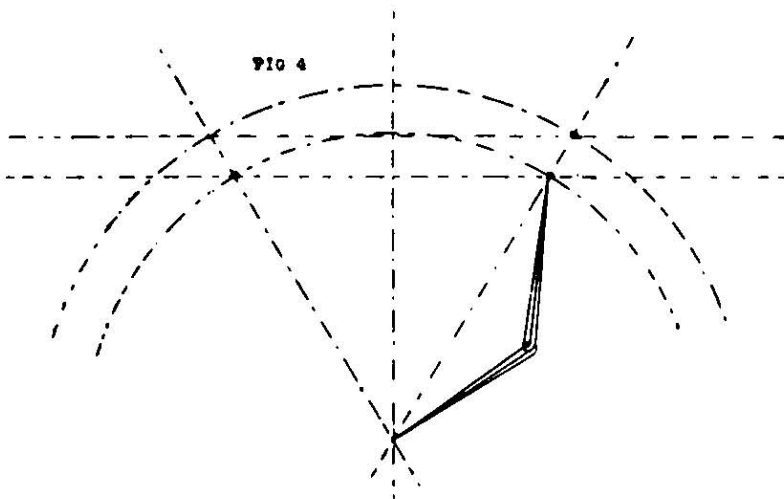
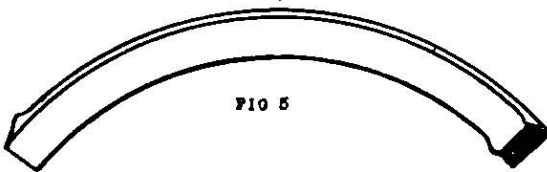

FIG 5



ESTIMATION OF LENGTHS OF MATERIAL.
PLATE 39

BEVEL CLAM

PLATE 39: FIG. 1 illustrates a bevel clam with top inside measurement 6 ins., and bottom inside measurement 8 ins. The following illustrations show the method of making it. The procedure is similar to that in making a coned hoop, i.e. the bar must be bent edgeways.

FIG. 2 shows the straight bar marked 6 ins. and 8 ins. also showing the correct angle A to which the bar should be bent edgeways.

FIG. 3 shows the bar bent edgeways.

FIG. 4 shows the bar bent along the line B-C.

BEVEL CLAM.

PLATE 39

FIG 1

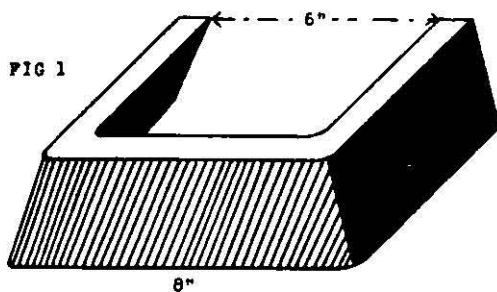

FIG 2

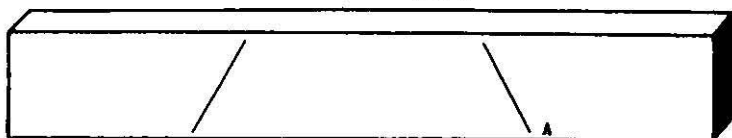

FIG 3

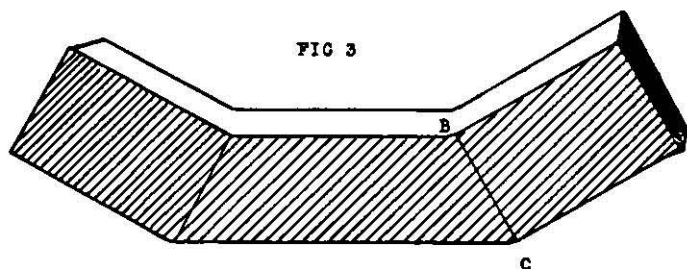
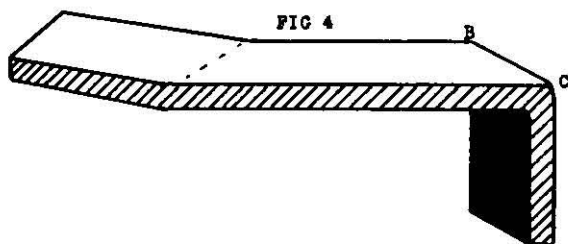

FIG 4



ESTIMATION OF LENGTHS OF MATERIAL.
PLATE 40

ANGLE BAR RINGS

PLATE 40: FIG. 1 illustrates an angle bar ring with the flange bent on the inside.

FIG. 2 gives the size of the ring which is 20 ins. When the flange is bent on the inside the ring is usually measured to the extreme diameter, as shown. The method of ascertaining the length is as follows: from the diameter 20 ins., subtract twice the diagonal thickness 1 in. at A, and multiply the answer by 3.1416,
 $20 \text{ ins.} - 2 \text{ ins.} = 18 \text{ ins.}$ $18 \text{ ins.} \times 3.1416 = 56.5 \text{ ins.}$

FIG. 3 illustrates the flange on the outside. The method to adopt in this case is to take the interior diameter, add twice the diagonal thickness and multiply their sum by 3.1416.

FIG. 4 gives the interior size, 20 ins. Method of ascertaining the length is as follows: $20 \text{ ins.} + 2 \text{ ins.} = 22 \text{ ins.}$
 $22 \text{ ins.} \times 3.1416 = 69 \text{ ins.}$

FIG. 5 illustrates method of bending small angle bars. Supposing the angle bar to be bent is 2 ins. by 2 ins., take a bar of 2 ins. square and bend it to the same radius that is required on the angle bar, then bend one end to fit the hole in the anvil as shown. When the angle bar is hot, grip the end as shown and pull around against the 2-inch square bar.

ANGLE BAR RINGS. PLATE 40

FIG 1

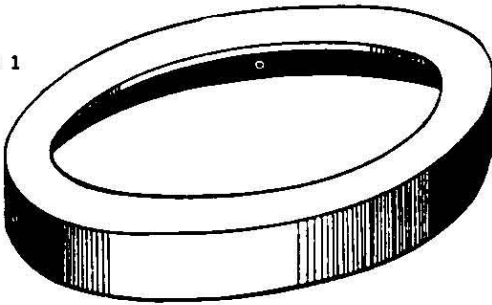

FIG 2

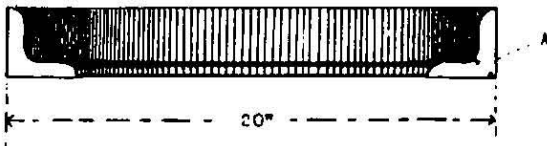

FIG 3

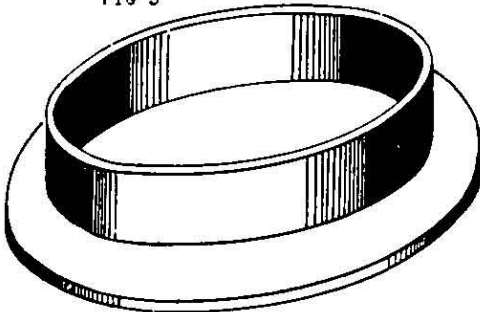

FIG 4

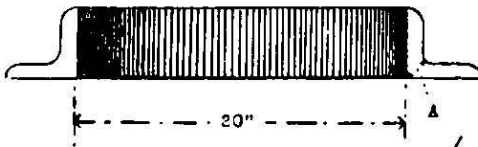
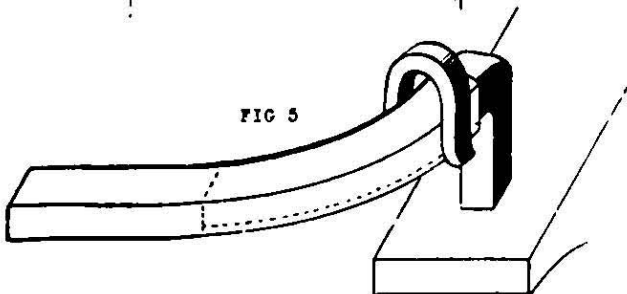

FIG 5



MISCELLANEOUS EXAMPLES OF FORGED
WORK IN DIFFERENT STAGES. PLATE 41

SIDE SETS

PLATE 41 illustrates side sets being used for making various forgings.

FIG. 1 illustrates the side set in use.

FIG. 2 illustrates the result before being drawn down.

FIG. 3 illustrates the result after being drawn down.

FIG. 4 illustrates two side sets in use.

FIG. 5 illustrates the results before being drawn down.

FIG. 6 illustrates the results after being drawn down.

FIG. 7 illustrates how to get a smaller section into the centre of the bar, by using two side sets one above the other.

FIG. 8 illustrates the results before being drawn down.

FIG. 9 illustrates the results after being drawn down.

FIG. 10 illustrates the bar being side set on the four sides.

FIG. 11 illustrates the result before being drawn down.

FIG. 12 illustrates the result after being drawn down.

To side set a round bar it is advisable to recess it when hot by placing a small diameter bar on top, and keep turning the large bar until it is practically fullered to the depth of the small diameter bar, as shown in FIG. 13.

FIG. 14 illustrates the placing of the side sets in the recess and continually turning the bar.

FIG. 15 illustrates the results.

FIG. 16 illustrates the method that is adopted when fullering a flat bar, by means of a round bar being hammered in.

FIG. 17 illustrates the result before being drawn down.

FIG. 18 illustrates the result after being drawn down.

FIG. 19 illustrates a round bar doubled to the required width and hammered in.

FIG. 20 illustrates the result similar to FIG. 6.

SIDE SETS.

PLATE 41

FIG 1

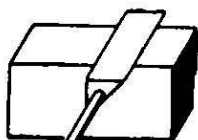

FIG 2



FIG 3



FIG 4

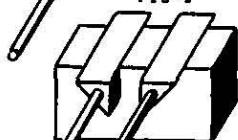

FIG 5



FIG 6

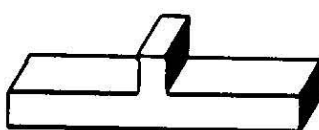

FIG 7

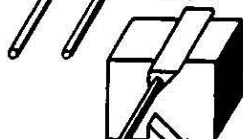

FIG 8

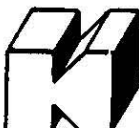

FIG 9



FIG 10



FIG 11



FIG 12

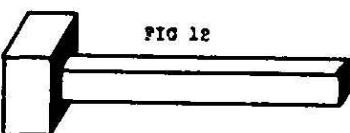

FIG 13



FIG 14



FIG 15



FIG 16

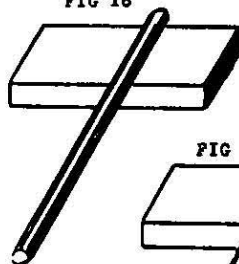

FIG 17



FIG 18



FIG 19

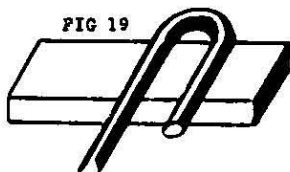
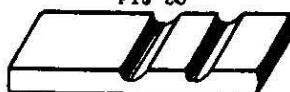

FIG 20



MISCELLANEOUS EXAMPLES OF FORGED
WORK IN DIFFERENT STAGES. PLATE 42

WELDING METHODS

Welding is the combining together of two pieces of iron or mild steel. This is done by heating both pieces to a plastic state, then hammering one into the other so as to form one solid bar. During the heating process it is necessary that the heated iron should be kept from coming in contact with the air-blast, the reason for this being that heated iron absorbs oxygen, thus forming a scale and preventing a good weld. Sand is a very good flux when welding mild steel. It melts and covers the heated surface, thus protecting it from oxidation and therefore is of great assistance in making a good weld.

FIG. 1 illustrates a scarf weld commonly used.

FIG. 2 illustrates a fork and wedge weld used for welding steel into iron.

FIG. 3 illustrates a butt weld which is used when one end is close up to a shoulder.

FIG. 4 illustrates a V-weld suitable for heavy rings.

FIG. 5 illustrates a stud weld, i.e. a round bar welded into a square bar forming a T-piece.

FIG. 6 illustrates another stud weld.

FIG. 7 illustrates a rivet weld suitable when making large hoops.

FIG. 8 illustrates a scarf weld suitable for small rings.

FIG. 9 is showing FIG. 1 welding under the hammer.

FIG. 10 is showing FIG. 2 welding under the hammer.

FIG. 11 is showing FIG. 4 welding under the hammer.

FIG. 12 illustrates a method of scarfing under the steam hammer.

WELDING METHODS. PLATE 42

FIG 1



FIG 2



FIG 3

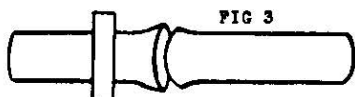

FIG 4

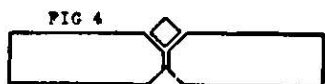

FIG 5

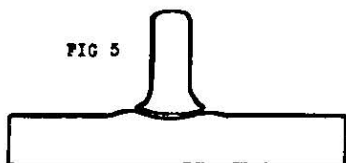

FIG 6

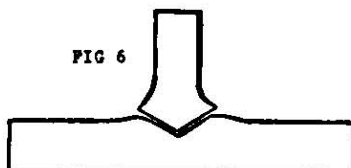

FIG 7



FIG 8

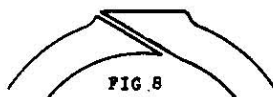

FIG 9

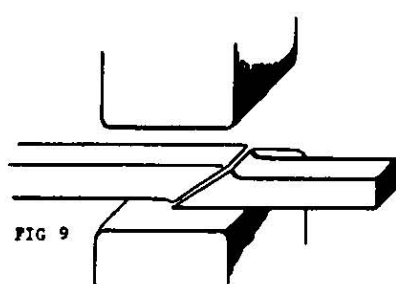

FIG 10

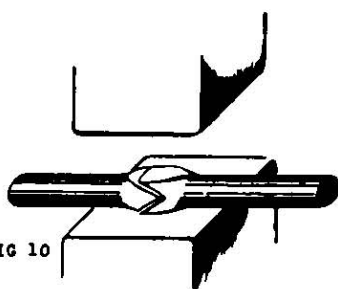

FIG 11

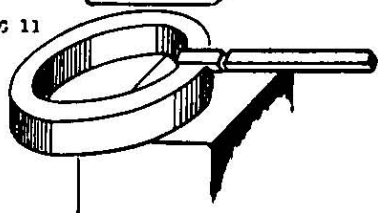
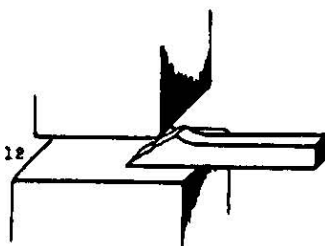

FIG 12



MISCELLANEOUS EXAMPLES OF FORGED
WORK IN DIFFERENT STAGES. PLATE 43

JUMPING

PLATE 43 gives a few examples of jumping. This process is used to increase the diameter, width, or thickness, at the same time reducing the length.

FIG. 1 shows a heavy flat bar turned up at each end used as an apparatus for jumping. The method of using this bar is shown. By heating the bar to be jumped, and then bending it, it can be placed between the two uprights and hammered where it is hot, thus jumping it to the required length. If the uprights are too far apart to enable the bar to be jumped between them, this can be remedied as shown.

FIG. 2 shows a method of jumping, by gripping the bar while hot under the steam hammer, and striking it with a ram, which is suspended by a chain from any convenient beam overhead.

FIG. 3 shows a pin bolt. Its head is 6 ins. diameter and 1 in. thick; its length, excluding the head, is 6 ins. having a diameter 4 ins. To make this pin bolt out of a 4-inch diameter bar, $2\frac{3}{8}$ ins. must be allowed for the head alone, making the total length of a 4-inch diameter bar required, $8\frac{3}{8}$ ins.

FIG. 4 shows the end of the 4-inch diameter bar being jumped under the steam hammer. The jumping is improved and better start given to the head by holding a flat bar on the 4-inch diameter bar, where the hammer strikes.

FIG. 5 shows another method of making a pin bolt by placing the 4-inch diameter bar in a bolster which has a recess for the head, and hammering down to form the head in the recess.

JUMPING.

PLATE 43

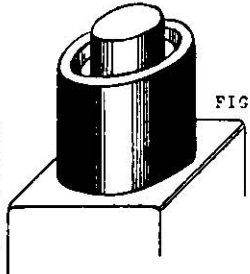
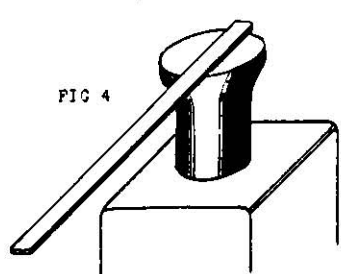
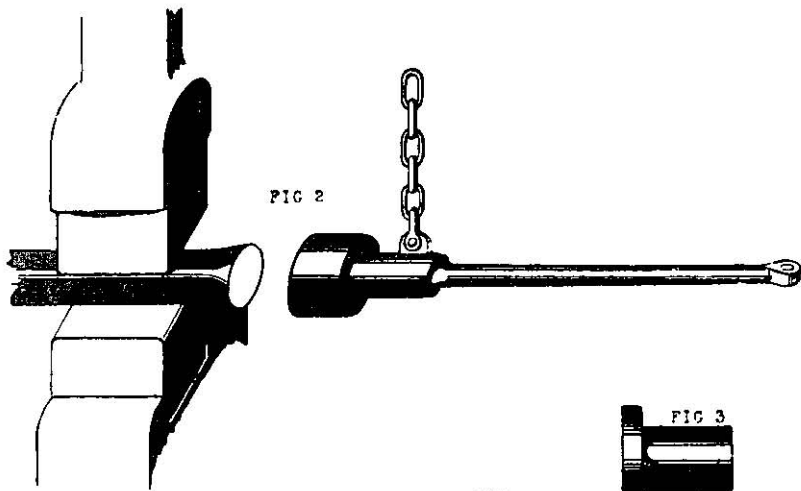
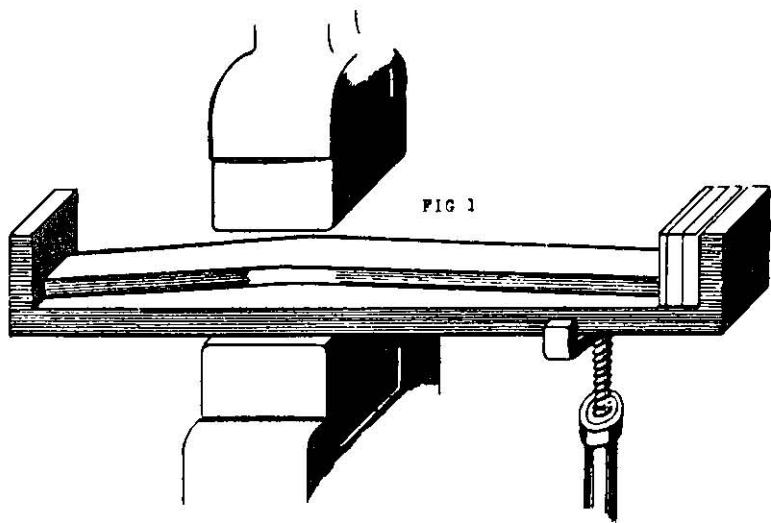

MISCELLANEOUS EXAMPLES OF FORGED
WORK IN DIFFERENT STAGES. PLATE 44

SUPPORTS

PLATE 44 illustrates various supports or adjusting stands necessary for supporting bars which are too long for the smith to handle.

FIG. 1 shows a stand which can be adjusted by placing a rod through the holes.

FIGS. 2 to 6 show the parts by which the structure of the stand shown in FIG. 1 is composed.

FIG. 7 shows another type of stand which can be easily adjusted by screwing up or down.

The stand in FIG. 8 is similar to the one shown in FIG. 7, except that when adjusted it is held by a set screw.

SUPPORTS.

PLATE 44

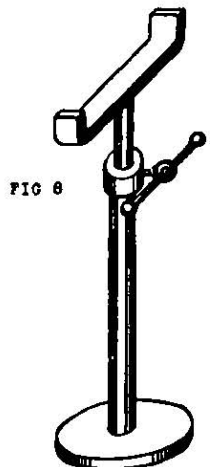
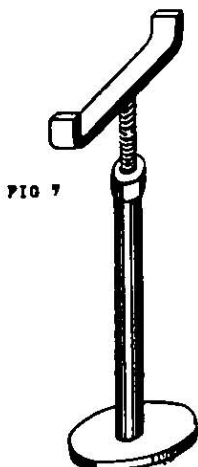
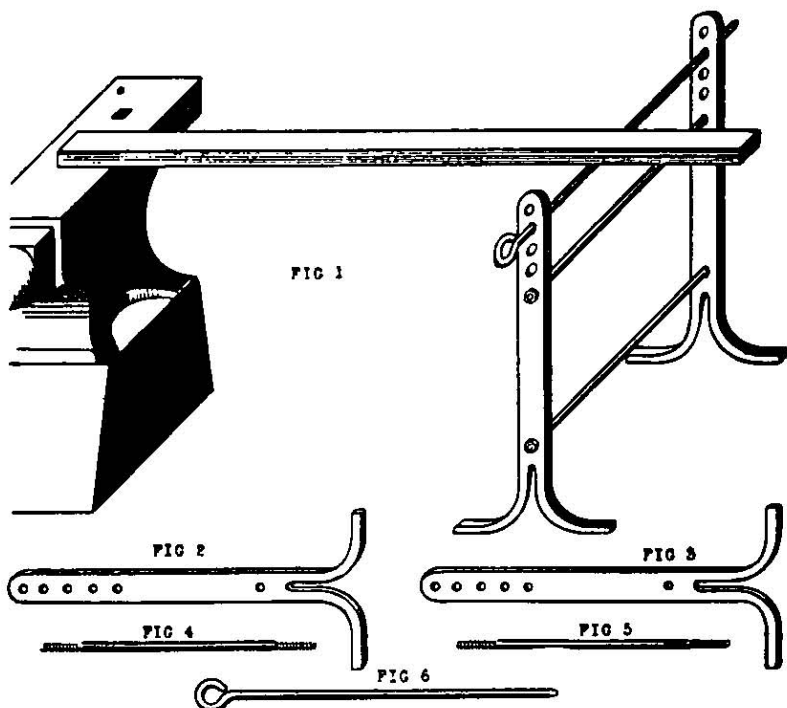

MISCELLANEOUS EXAMPLES OF FORGED
WORK IN DIFFERENT STAGES. PLATE 45

EASY METHODS

PLATE 45 illustrates a few easy methods for obtaining quick results with small material.

FIG. 1 shows a four-cornered clam made by heating the bar and laying it across a recessed tool. Then, by placing a bar across, as shown in FIG. 2, one blow under the steam hammer gives the result seen in FIG. 3.

FIG. 4 shows a clam.

FIG. 5 shows an arrangement for making clams, using two bars edgeways, which are regulated by four adjusting bolts to suit the size of clams to be made. To make the clam, lay the hot bar across the two bars and hammer the top tool down as shown.

FIG. 6 shows another method of making clams by using a recessed tool, but in this case one size of clam only can be made.

FIG. 7 shows a joggled bar, the method of joggling being shown in FIGS. 8 and 9.

FIG. 10 shows a pipe hanger, which can be made by first making a template around which the pipe hangers can be shaped. These operations are shown in FIGS. 10 to 12.

FIG. 13 shows a flat bar with two bends close together. FIG. 14 shows a bar fixed in the anvil with the flat bar laid across, gripped with the tongs, and the ends hammered over, as shown in FIG. 15.

Note.—These methods are adopted when numerous jobs of the same type have to be made.

EASY METHODS. PLATE 45

