

Fuels and Furnaces

BY

MARTIN D. SCHLESINGER *Wallingford Group, Ltd.*
 KLEMENS C. BACZEWSKI *Consulting Engineer*
 GLENN W. BAGGLEY *Manager, Regenerative Systems, Bloom Engineering Co., Inc.*
 CHARLES O. VELZY *Consultant*
 ROGER S. HECKLINGER *Project Director, Roy F. Weston of New York, Inc.*
 GEORGE J. RODDAM *Sales Engineer, Lectromelt Furnace Division, Salem Furnace Co.*

7.1 FUELS

by Martin D. Schlesinger and Associates

Coal (BY M. D. SCHLESINGER)	7-2
Biomass Fuels (BY M. D. SCHLESINGER)	7-8
Petroleum and Other Liquid Fuels (BY JAMES G. SPEIGHT)	7-10
Gaseous Fuels (BY JAMES G. SPEIGHT)	7-14
Synthetic Fuels (BY M. D. SCHLESINGER)	7-16
Explosives (BY J. EDMUND HAY)	7-19
Dust Explosions (BY HARRY C. VERAKIS AND JOHN NAGY)	7-22
Rocket Fuels (BY RANDOLPH T. JOHNSON)	7-28

7.2 CARBONIZATION OF COAL AND GAS MAKING

by Klemens C. Baczewski

Carbonization of Coal	7-31
Carbonizing Apparatus	7-33
Gasification	7-35

7.3 COMBUSTION FURNACES

by Glenn W. Baggley

Fuels	7-41
Types of Industrial Heating Furnaces	7-41
Size and Economy of Furnaces	7-42
Furnace Construction	7-44

Heat-Saving Methods	7-44
Special Atmospheres	7-45

7.4 INCINERATION

by Charles O. Velzy and Roger S. Hecklinger

Nature of the Fuel	7-45
Types of Furnaces	7-46
Plant Design	7-46
Furnace Design	7-46
Combustion Calculations	7-49
Recovery	7-51

7.5 ELECTRIC FURNACES AND OVENS

by George J. Roddam

Classification and Service	7-52
Resistor Furnaces	7-52
Dielectric Heating	7-55
Induction Heating	7-55
Arc Furnaces	7-55
Induction Furnaces	7-55
Power Requirements for Electric Furnaces	7-58
Submerged-Arc and Resistance Furnaces	7-59

7.1 FUELS

by Martin D. Schlesinger and Associates

COAL

by Martin D. Schlesinger

Wallingford Group, Ltd.

REFERENCES: Petrography of American Coals, *U.S. BuMines Bull.* 550. Lowry, "Chemistry of Coal Utilization," Wiley. ASTM, "Standards on Gaseous Fuels, Coal and Coke." Methods of Analyzing and Testing Coal and Coke, *U.S. BuMines Bull.* 638. Karr, "Analytical Methods for Coal and Coal Products," Academic. Preprints, Division of Fuel Chemistry, American Chemical Society.

Coal is a black or brownish-black combustible solid formed by the decomposition of vegetation in the absence of air. Microscopy can identify plant tissues, resins, spores, etc. that existed in the original structure. It is composed principally of carbon, hydrogen, oxygen, and small amounts of sulfur and nitrogen. Associated with the organic matrix are water and as many as 65 other chemical elements. Many trace elements can be determined by spectrometric method D-3683. Coal is used directly as a fuel, a chemical reactant, and a source of organic chemicals. It can also be converted to liquid and gaseous fuels.

Classification and Description

Coal may be classified by rank, by variety, by size and sometimes by use. Rank classification takes into account the degree of metamorphism or progressive alteration in the natural series from lignite to anthracite. Table 7.1.1 shows the classification of coals by rank adopted as standard by the ASTM (method D-388). The basic scheme is according to fixed carbon (FC) and heating value (HV) from a proximate analysis, calculated on the mineral-matter-free (mmf) basis. The higher-rank coals are classified according to the FC on a dry basis and the lower-rank according to HV in Btu on a moist basis. **Agglomerating** character is used to differentiate between certain adjacent groups. Coals are considered agglomerating if, in the test to determine volatile matter, they produce either a coherent button that will support a 500-g weight or a button that shows swelling or cell structure.

For classifying coals according to rank, FC and HV can be calculated to a moisture-free basis by the **Parr formulas**, Eqs. (7.1.1) to (7.1.3) below:

$$FC \text{ (dry, mmf)} = \frac{FC - 0.15S}{100 - (M + 1.08A + 0.55S)} \times 100 \quad (7.1.1)$$

$$VM \text{ (dry, mmf)} = 100 - FC \quad (7.1.2)$$

$$HV \text{ (moist, mmf)} = \frac{Btu - 50S}{100 - (1.08A + 0.55S)} \quad (7.1.3)$$

where FC = percentage of fixed carbon, VM = percentage of volatile matter, M = percentage of moisture, A = percentage of ash, S = percentage of sulfur, all on a moist basis. "Moist" coal refers to the natural bed moisture, but there is no visible moisture on the surface. HV = heating value, Btu/lb (Btu/lb \times 0.5556 = g · cal/g). Because of its complexity, the analysis of coal requires care in sampling, preparation, and selection of the method of analysis.

Figure 7.1.1 shows representative proximate analyses and heating values of various ranks of coal in the United States. The analyses were calculated to an ash-free basis because ash is not a function of rank. Except for anthracite, FC and HV increase from the lowest to the highest rank as the percentages of volatile matter and moisture decrease. The sources and analyses of coals representing various ranks are given in Table 7.1.2.

Meta-anthracite is a high-carbon coal that approaches graphite in

structure and composition. It usually is slow to ignite and difficult to burn. It has little commercial importance.

Anthracite, sometimes called hard coal, is hard, compact, and shiny black, with a generally conchoidal fracture. It ignites with some difficulty and burns with a short, smokeless, blue flame. Anthracite is used primarily for space heating and as a source of carbon. It is also used in

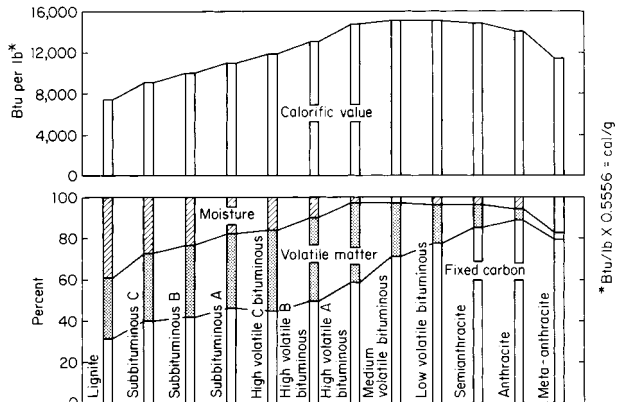

Fig. 7.1.1 Proximate analysis and heating values of various ranks of coal (ash-free basis).

electric power generating plants in or close to the anthracite-producing area. The iron and steel industry uses some anthracite in blends with bituminous coal to make coke, for sintering iron-ore fines, for lining pots and molds, and as a substitute for coke in foundries.

Semianthracite is dense, but softer than anthracite. It burns with a short, clean, bluish flame and is somewhat more easily ignited than anthracite. The uses are about the same as for anthracite.

Low-volatile bituminous coal is grayish black, granular in structure and friable on handling. It cakes in a fire and burns with a short flame that is usually considered smokeless under all burning conditions. It is used for space heating and steam raising and as a constituent of blends for improving the coke strength of higher-volatile bituminous coals. Low-volatile bituminous coals cannot be carbonized alone in slot-type ovens because they expand on coking and damage the walls of the ovens.

Medium-volatile bituminous coal is an intermediate stage between high-volatile and low-volatile bituminous coal and therefore has some of the characteristics of both. Some are fairly soft and friable, but others are hard and do not disintegrate on handling. They cake in a fuel bed and smoke when improperly fired. These coals make cokes of excellent strength and are either carbonized alone or blended with other bituminous coals. When carbonized alone, only those coals that do not expand appreciably can be used without damaging oven walls.

High-volatile A bituminous coal has distinct bands of varying luster. It is hard and handles well with little breakage. It includes some of the best steam and coking coal. On burning in a fuel bed, it cakes and gives off smoke if improperly fired. The coking property is often improved by blending with more strongly coking medium- and low-volatile bituminous coal.

High-volatile B bituminous coal is similar to high-volatile A bituminous coal but has slightly higher bed moisture and oxygen content and is less strongly coking. It is good coal for steam raising and space heating.

Table 7.1.1 Classification of Coals by Rank (ASTM D388)*

Class	Group	Fixed-carbon limits, percent (dry, mineral-matter-free basis)		Volatile-matter limits, percent (dry, mineral-matter-free basis)		Calorific value limits, Btu/lb (moist, † mineral-matter-free basis)		Agglomerating character
		Equal or greater than	Less than	Greater than	Equal or less than	Equal or greater than	Less than	
I. Anthracitic	1. Meta-anthracite	98	2			Nonagglomerating ‡
	2. Anthracite	92	98	2	8			
	3. Semianthracite	86	92	8	14	
II. Bituminous	1. Low-volatile bituminous coal	78	86	14	22	} Commonly agglomerating ¶
	2. Medium-volatile bituminous coal	69	78	22	31	
	3. High-volatile A bituminous coal	...	69	31	...	14,000§	
	4. High-volatile B bituminous coal	13,000§	14,000	
	5. High-volatile C bituminous coal	11,500	13,000	
					10,500	11,500	Agglomerating	
III. Subbituminous	1. Subbituminous A coal	10,500	11,500	Nonagglomerating
	2. Subbituminous B coal	9,500	10,500	
	3. Subbituminous C coal	8,300	9,500	
IV. Lignitic	1. Lignite A	6,300	8,300	
	2. Lignite B	6,300	

* This classification does not include a few coals, principally nonbanded varieties, which have unusual physical and chemical properties and which come within the limits of fixed-carbon or calorific value of the high-volatile bituminous and subbituminous ranks. All of these coals either contain less than 48 percent dry, mineral-matter-free fixed carbon or have more than 15,500 moist, mineral-matter-free British thermal units per pound. Btu/lb × 2.323 = kJ/kg.

† Moist refers to coal containing its natural inherent moisture but not including visible water on the surface of the coal.

‡ If agglomerating, classify in low-volatile group of the bituminous class.

§ Coals having 69 percent or more fixed carbon on the dry, mineral-matter-free basis are classified according to fixed carbon, regardless of calorific value.

¶ It is recognized that there may be nonagglomerating varieties in these groups of the bituminous class, and there are notable exceptions in the high-volatile C bituminous group.

Table 7.1.2 Sources and Analyses of Various Ranks of Coal as Received

Classification by rank	State	County	Bed	Proximate, %			Ash†	Ultimate, %					Calorific value, Btu/lb*
				Moisture	Volatile matter	Fixed carbon		Sulfur	Hydrogen	Carbon	Nitrogen	Oxygen	
Meta-anthracite	Rhode Island	Newport	Middle	13.2	2.6	65.3	18.9	0.3	1.9	64.2	0.2	14.5	9,310
Anthracite	Pennsylvania	Lackawanna	Clark	4.3	5.1	81.0	9.6	0.8	2.9	79.7	0.9	6.1	12,880
Semianthracite	Arkansas	Johnson	Lower Hartshorne	2.6	10.6	79.3	7.5	1.7	3.8	81.4	1.6	4.0	13,880
Low-volatile bituminous coal	West Virginia	Wyoming	Pocahontas no. 3	2.9	17.7	74.0	5.4	0.8	4.6	83.2	1.3	4.7	14,400
Medium-volatile bituminous coal	Pennsylvania	Clearfield	Upper Kittanning	2.1	24.4	67.4	6.1	1.0	5.0	81.6	1.4	4.9	14,310
High-volatile A bituminous coal	West Virginia	Marion	Pittsburgh	2.3	36.5	56.0	5.2	0.8	5.5	78.4	1.6	8.5	14,040
High-volatile B bituminous coal	Kentucky, western field	Muhlenburg	No. 9	8.5	36.4	44.3	10.8	2.8	5.4	65.1	1.3	14.6	11,680
High-volatile C bituminous coal	Illinois	Sangamon	No. 5	14.4	35.4	40.6	9.6	3.8	5.8	59.7	1.0	20.1	10,810
Subbituminous A coal	Wyoming	Sweetwater	No. 3	16.9	34.8	44.7	3.6	1.4	6.0	60.4	1.2	27.4	10,650
Subbituminous B coal	Wyoming	Sheridan	Monarch	22.2	33.2	40.3	4.3	0.5	6.9	53.9	1.0	33.4	9,610
Subbituminous C coal	Colorado	El Paso	Fox Hill	25.1	30.4	37.7	6.8	0.3	6.2	50.5	0.7	35.5	8,560
Lignite	North Dakota	McLean	Unnamed	36.8	27.8	29.5	5.9	0.9	6.9	40.6	0.6	45.1	7,000

* Btu/lb × 2.325 = J/g; Btu/lb × 0.5556 = g·cal/g.

† Ash is part of both the proximate and ultimate analyses.

Some of it is blended with more strongly coking coals for making metallurgical coke.

High-volatile C bituminous coal is a stage lower in rank than the B bituminous coal and therefore has a progressively higher bed moisture and oxygen content. It is used primarily for steam raising and space heating.

Subbituminous coals usually show less evidence of banding than bituminous coals. They have a high moisture content, and on exposure to air, they disintegrate or "slack" because of shrinkage from loss of moisture. They are noncaking and noncoking, and their primary use is for steam raising and space heating.

Lignites are brown to black in color and have a bed moisture content of 30 to 45 percent with a resulting lower heating value than higher-rank coals. Like subbituminous coals, they have a tendency to "slack" or disintegrate during air drying. They are noncaking and noncoking. Lignite can be burned on traveling or spreader stokers and in pulverized form.

The principal ranks of coal mined in the major coal-producing states are shown in Table 7.1.3. Their analyses depend on several factors, e.g., source, size of coal, and method of preparation. Periodic reports are issued by the U.S. Department of Energy, Energy Information Agency. They provide statistics on production, distribution, end use, and analytical data.

Composition and Characteristics

Proximate analysis, sulfur content, and calorific values are the analytical determination most commonly used for industrial characterization of coal. The **proximate analysis** is the simplest means for determining the distribution of products obtained during heating. It separates the products into four groups: (1) water or moisture, (2) volatile matter consisting of gases and vapors, (3) fixed carbon consisting of the carbonized residue less ash, and (4) ash derived from the mineral impurities in the coal. ASTM methods D3712 and D5142 are used; the latter is an instrumental method.

Moisture is the loss in weight obtained by drying the coal at a temperature between 104 and 110°C (220 and 230°F) under prescribed conditions. Further heating at higher temperatures may remove more water,

but this moisture usually is considered part of the coal substance. The moisture obtained by the standard method consists of (1) surface or extraneous moisture that may come from external sources such as percolating waters in the mine, rain, condensation from the air, or water from a coal washery; (2) inherent moisture, sometimes called **bed moisture**, which is so closely held by the coal substance that it does not separate these two types of moisture. A coal may be air-dried at room temperature or somewhat above, thereby determining an "air-drying loss," but this result is not the extraneous moisture because part of the inherent moisture also vaporizes during the drying.

Mine samples taken at freshly exposed faces in the mine, which are free from visible surface moisture, give the best information as to inherent or bed moisture content. Such moisture content ranges in value from 2 to 4 percent for anthracite and for bituminous coals of the eastern Appalachian field, such as the Pocahontas, Sewell, Pittsburgh, Freeport, and Kittanning beds. In the western part of this field, especially in Ohio, the inherent moisture ranges from 4 to 10 percent. In the interior fields of Indiana, Illinois, western Kentucky, Iowa, and Missouri, the range is from 8 to 17 percent. In subbituminous coals the inherent moisture ranges from 15 to 30 percent, and in lignites from 30 to 45 percent. The total amount of moisture in commercial coal may be greater or less than that of the coal in the mine. Freshly mined subbituminous coal and lignite lose moisture rapidly when exposed to the air. The extraneous or surface moisture in coal is a function of the surface exposed, each surface being able to hold a film of moisture. Fine sizes hold more moisture than lump. Coal which in the mine does not contain more than 4 percent moisture may in finer sizes hold as much as 15 percent; the same coal in lump sizes, even after underwater storage, may contain little more moisture than originally in the mine.

In the standard method of analysis, the **volatile matter** is taken as the loss in weight, less moisture, obtained by heating the coal for 7 min in a covered crucible at about 950°C (1,742°F) under specified conditions. Volatile matter does not exist in coal as such but is produced by decomposition of the coal when heated. It consists chiefly of the combustible gases, hydrogen, carbon monoxide, methane and other hydrocarbons, tar vapors, volatile sulfur compounds, and some noncombustible gases such as carbon dioxide and water vapor. The composition of the volatile

Table 7.1.3 Principal Ranks of Coal Mined in Various States*

State	Anthracite	Semi-anthracite	Low-volatile bituminous	Medium-vol. bituminous	High-vol. A bituminous	High-vol. B bituminous	High-vol. C bituminous	Subbituminous A	Subbituminous B	Subbituminous C	Lignite
Alabama				x	x						
Alaska						x	x	x	x	x	x
Arkansas		x	x	x	x						x
Colorado					x	x	x	x	x	x	x
Illinois					x	x	x				
Indiana						x	x				
Iowa							x				
Kansas					x	x					
Kentucky											
Eastern					x	x					
Western					x	x	x				
Maryland			x	x	x						
Missouri							x				
Montana						x	x	x	x	x	x
New Mexico					x	x	x		x		
North Dakota											x
Ohio					x	x	x				
Oklahoma			x	x	x	x	x				
Pennsylvania	x	x	x	x	x						
South Dakota											x
Tennessee				x	x						
Texas							x	x			x
Utah					x	x	x	x	x		
Virginia		x	x	x	x						
Washington					x	x	x		x		x
West Virginia			x	x	x						
Wyoming						x	x	x	x	x	

* Compiled largely from Typical Analyses of Coals of the United States, *BuMines Bull.* 446, and Coal Reserves of the United States, *Geol. Survey Bull.* 1136.

matter varies greatly with different coals: the amount can vary with the rate of heating. The inert or noncombustible gas may range from 4 percent of the total volatile matter in low-volatile coals to 40 percent in subbituminous coals.

The standard method of determining the **fixed carbon** is to subtract from 100 the sum of the percentages of the moisture, volatile matter, and ash of the proximate analysis. It is the carbonaceous residue less ash remaining in the test crucible in the determination of the volatile matter. It does not represent the total carbon in the coal because a considerable part of the carbon is expelled as volatile matter in combination with hydrogen as hydrocarbons and with oxygen as carbon monoxide and carbon dioxide. It also is not pure carbon because it may contain several tenths percent of hydrogen and oxygen, 0.4 to 1.0 percent of nitrogen, and about half of the sulfur that was in the coal.

In the standard method, **ash** is the inorganic residue that remains after burning the coal in a muffle furnace to a final temperature of 700 to 750°C (1,292 to 1,382°F). It is composed largely of compounds of silicon, aluminum, iron, and calcium, with smaller quantities of compounds of magnesium, titanium, sodium, and potassium. The ash as determined is usually less than the inorganic mineral matter originally present in the coal. During incineration, various weight changes take place, such as loss of water of constitution of the silicate minerals, loss of carbon dioxide from carbonate minerals, oxidation of iron pyrites to iron oxide, and fixation of a part of the oxides of sulfur by bases such as calcium and magnesium.

The chemical composition of coal ash varies widely depending on the mineral constituents associated with the coal. Typical limits of ash composition of U.S. bituminous coals are as follows:

Constituent	Percent
Silica, SiO ₂	20–40
Alumina, Al ₂ O ₃	10–35
Ferric oxide, Fe ₂ O ₃	5–35
Calcium oxide, CaO	1–20
Magnesium oxide, MgO	0.3–4
Titanium dioxide, TiO ₂	0.5–2.5
Alkalies, Na ₂ O and K ₂ O	1–4
Sulfur trioxide, SO ₃	0.1–12

The ash of subbituminous coals may have more CaO, MgO, and SO₃ than the ash of bituminous coals; the trend may be even more pronounced for lignite ash.

Ultimate analysis expresses the composition of coal as sampled in percentages of carbon, hydrogen, nitrogen, sulfur, oxygen, and ash. The carbon includes that present in the organic coal substance as well as a minor amount that may be present as mineral carbonates. In ASTM practice, the hydrogen and oxygen values include those of the organic coal substance as well as those present in the form of moisture and the water of constitution of the silicate minerals. In certain other countries, the values for hydrogen and oxygen are corrected for the moisture in the coal and are reported separately. The ash is the same as reported in the proximate analysis; the sulfur, carbon, hydrogen, and nitrogen are determined chemically. Oxygen in coal is usually estimated by subtracting the sum of carbon, hydrogen, nitrogen, sulfur, and ash from 100. Many of the analyses discussed can be performed with modern instruments in a short time. ASTM methods are applied when referee data are required.

Sulfur occurs in three forms in coal: (1) **pyritic sulfur**, or sulfur combined with iron as pyrite or marcasite; (2) **organic sulfur**, or sulfur combined with coal substance as a heteroatom or as a bridge atom; (3) **sulfate sulfur**, or sulfur combined mainly with iron or calcium together with oxygen as iron sulfate or calcium sulfate. Pyrite and marcasite are recognized by their metallic luster and pale brass-yellow color, although some marcasite is almost white. Organic sulfur may comprise from about 20 to 85 percent of the total sulfur in the coal. Most freshly mined coal contains only very small quantities of sulfate sulfur; it increases in weathered coal. The total sulfur content of coal mined in the United States varies from about 0.4 to 5.5 percent by weight on a dry coal basis.

The **gross calorific value** of a fuel expressed in Btu/lb of fuel is the heat produced by complete combustion of a unit quantity, at constant volume, in an oxygen bomb calorimeter under standard conditions. It includes the latent heat of the water vapor in the products of combustion. Since the latent heat is not available for making steam in actual operation of boilers, a net calorific value is sometimes determined, although not in usual U.S. practice, by the following formula:

$$\text{Net calorific value, Btu/lb} = \text{gross calorific value, Btu/lb} \\ - (92.70 \times \text{total hydrogen, \% in coal})$$

The gross calorific value may also be approximated by Dulong's formula

$$\text{Btu/lb} = 14,544C + 62,028 \left(H - \frac{O}{8} \right) + 4,050S \\ (\text{Btu/lb} \times 2.328 = \text{kJ/kg})$$

where C, H, O, and S are weight fractions from the ultimate analysis. For anthracites, semianthracites, and bituminous coals, the calculated values are usually with 1/2 percent of those determined by the bomb calorimeter. For subbituminous and lignitic coals, the calculated values show deviations often reaching 4 and 5 percent.

Because coal ash is a mixture of various components, it does not have a definite melting point; the gradual softening and fusion of the ash is not merely the successive melting of the various ash constituents but is a more complicated process in which reactions involving the formation of new and more fusible compounds take place.

The **fusibility of coal ash** is determined by heating a triangular pyramide (cone), 3/4 in high and 3/4 in wide at each side of the base, made up of the ash together with a small amount of organic binder. As the cone is heated, three temperatures are noted: (1) the initial deformation temperature (IDT), or the temperature at which the first rounding of the apex or the edges of the cone occurs; (2) the softening temperature (ST), or the temperature at which the cone has fused down to a spherical lump; and (3) the fluid temperature (FT), or the temperature at which the cone has spread out in a nearly flat layer. The softening interval is the degrees of temperature difference between (2) and (1), the flowing interval the difference between (3) and (2), and the fluidity range the difference between (3) and (1). Of the three, the softening temperature is most widely used. Table 7.1.4 shows ash-fusion data typical of some important U.S. coals.

Data on ash fusion characteristics are useful to the combustion engineer concerned with evaluation of the clinking tendencies of coals used in combustion furnaces and with corrosion of metal surfaces in boilers due to slag deposits. The kinds of mineral matter occurring in different coals are not well related to rank or geographic location, al-

Table 7.1.4 Fusibility of Ash from Some Coals

Seam	Pocahontas						
	no. 3	Ohio no. 9	Pittsburgh	Illinois	Utah	Wyoming	Texas
Type	Low volatile	High volatile	High volatile	High volatile	High volatile	Subbituminous	Lignite
Ash, %	12.3	14.1	10.9	17.4	6.6	6.6	12.8
Temperature, °C*							
Initial deformation	> 1,600	1,325	1,240	1,260	1,160	1,200	1,190
Softening		1,430	1,305	1,330		1,215	1,200
Fluid		1,465	1,395	1,430	1,350	1,260	1,255

* In an oxidizing atmosphere.

though there is a tendency for midcontinent coals (Indiana to Oklahoma) to have low ash fusion temperatures. Significance is attached to all of the previously indicated fusion temperatures and the intervals between them. The IDT is sometimes identified with surface stickiness, the ST with plastic distortion or sluggish flow, and the FT with liquid mobility. Long fusion intervals often produce tough, dense, slags; short intervals favor porous, friable structures.

Most bituminous coals, when heated at uniformly increasing temperatures in the absence or partial absence of air, fuse and become plastic. These coals may be designated as either caking or coking in different degrees. **Caking** usually refers to the fusion process in a boiler furnace. **Caking coals** are those that make good coke, suitable for metallurgical purposes where the coke must withstand the burden of the ore and flux above it. Coals that are caking in a fuel bed do not necessarily make good coke in a coke oven. Subbituminous coal, lignite, and anthracite are noncaking.

The **free-swelling index** test measures the free-swelling properties of coal and gives an indication of the caking characteristics of the coal when burned on fuel beds. It is not intended to determine the expansion of coals in coke ovens. The test consists in heating 1 g of pulverized coal in a silica crucible over a gas flame under prescribed conditions to form a coke button, the size and shape of which are then compared with a series of standard profiles numbered 1 to 9 in increasing order of swelling.

The **specific gravity** of coal is the ratio of the weight of solid coal to the weight of an equal volume of water. It is useful in calculating the weight of solid coal as it occurs in the ground for estimating the tonnage of coal per acre of surface. An increase in ash-forming mineral matter increases the specific gravity; e.g., bituminous coals of Alabama, ranging from 2 to 15 percent ash and from 2 to 4.5 percent moisture, vary in specific gravity from 1.26 to 1.37.

Bulk density is the weight per cubic foot of broken coal. It varies according to the specific gravity of the coal, its size distribution, its moisture content, and the amount of orientation when piled. The range of weight from subbituminous coal to anthracite is from 44 to 59 lb/ft³ when loosely piled; when piled in layers and compacted, the weight per cubic foot may increase as much as 25 percent. The weight of fuel in a pile can usually be determined to within 10 to 15 percent by measuring its volume. Typical weights of coal, as determined by shoveling it loosely into a box of 8 ft³ capacity, are as follows: anthracite, 50 to 58 lb/ft³; low- and medium-volatile bituminous coal, 49 to 57 lb/ft³; high-volatile bituminous and subbituminous coal, 42 to 57 lb/ft³.

The **grindability** of coal, or the ease with which it can be ground fine enough for use as a pulverized fuel, is a composite of several specific physical properties such as hardness, tensile strength, and fracture. A laboratory procedure adopted by ASTM (D409) for evaluating grindability, known as the **Hardgrove** machine method, uses a specially designed grinding apparatus to determine the relative grindability or ease of pulverizing coal in comparison with a standard coal, chosen as 100 grindability. Primarily, the ASTM Hardgrove grindability test is used for estimating how various coals affect the capacity of commercial pulverizers. A general relationship exists between grindability of coal and its rank. Coals that are easiest to grind (highest grindability index) are those of about 14 to 30 percent volatile matter on a dry, ash-free basis. Coals of either lower or higher volatile-matter content usually are more difficult to grind. The relationship of grindability and rank, however, is not sufficiently precise for grindability to be estimated from the chemical analysis, partly because of the variation in grindability of the various petrographic and mineral components. Grindability indexes of U.S. coals range from about 20 for an anthracite to 120 for a low-volatile bituminous coal.

Mining

Coal is mined by either underground or surface methods. In underground mining the coal beds are made accessible through shaft, drift, or slope entries (vertical, horizontal, or inclined, respectively), depending on location of the bed relative to the terrain.

The most widely used methods of coal mining in the United States are

termed continuous and conventional mining. The former makes use of **continuous miners** which break the coal from the face and load it onto conveyors, shuttle cars, or railcars in one operation. Continuous miners are of ripping, boring, or milling types or hybrid combinations of these. In conventional mining the coal is usually broken from the face by means of blasting agents or by pressurized air or carbon dioxide devices. In preparation for breaking, the coal may be cut horizontally or vertically by cutting machines and holes drilled for charging explosives. The broken coal is then picked up by loaders and discharged to conveyors or cars. A method that is increasing in use is termed **long-wall mining**. It employs shearing or plowing machines to break coal from more extensive faces. Eighty long-wall mines are now in operation. Pillars to support the roof are not needed because the roof is caved under controlled conditions behind the working face. About half the coal presently mined underground is cut by machine and nearly all the mined coal is loaded mechanically.

An important requirement in all mining systems is **roof support**. When the roof rock consists of strong sandstone or limestone, relatively uncommon, little or no support may be required over large areas. Most mine roofs consist of shales and must be reinforced. Permanent supports may consist of arches, crossbars and legs, or single posts made of steel or wood. Screw or hydraulic jacks, with or without crossbars, often serve as temporary supports. Long roof bolts, driven into the roof and anchored in sound strata above, are used widely for support, permitting freedom of movement for machines. Drilling and insertion of bolts is done by continuous miners or separate drilling machines. **Ventilation** is another necessary factor in underground mining to provide a proper atmosphere for personnel and to dilute or remove dangerous concentrations of methane and coal dust. The ventilation system must be well-designed so that adequate air is supplied across the working faces without stirring up more dust.

When coal occurs near the surface, **strip or open-pit mining** is often more economical than underground mining. This is especially true in states west of the Mississippi River where coal seams are many feet thick and relatively low in sulfur. The proportion of coal production from surface mining has been increasing rapidly and now amounts to over 60 percent.

In preparation for surface mining, core drilling is conducted to survey the underlying coal seams, usually with dry-type rotary drills. The overburden must then be removed. It is first loosened by ripping or drilling and blasting. Ripping can be accomplished by bulldozers or scrapers. Overburden and coal are then removed by shovels, draglines, bulldozers, or wheel excavators. The first two may have bucket capacities of 200 yd³ (153 m³). Draglines are most useful for very thick cover or long dumping ranges. Hauling of stripped coal is usually done by trucks or tractor-trailers with capacities up to 240 short tons [218 metric tons (t)]. Reclamation of stripped coal land is becoming increasingly necessary. This involves returning the land to near its original contour, replanting with ground cover or trees, and sometimes providing water basins and arable land.

Preparation

About half the coal presently mined in the United States is cleaned mechanically to remove impurities and supply a marketable product. Mechanical mining has increased the proportion of fine coal and non-coal minerals in the product. At the preparation plant run-of-mine coal is usually given a preliminary size reduction with roll crushers or rotary breakers. Large or heavy impurities are then removed by hand picking or screening. Tramp iron is usually removed by magnets. Before washing, the coal may be given a preliminary size fractionation by screening. Nearly all preparation practices are based on density differences between coal and its associated impurities. **Heavy-medium** separators using magnetite or sand suspensions in water come closest to ideal gravity separation conditions. **Mechanical devices** include jigs, classifiers, washing tables, cyclones, and centrifuges. Fine coal, less than 1/4 in. (6.3 mm) is usually treated separately, and may be cleaned by froth flotation. Dewatering of the washed and sized coal may be accomplished by screening, centrifuging, or filtering, and finally, the fine coal may be

heated to complete the drying. Before shipment the coal may be dust-proofed and freezeproofed with oil or salt.

Removal of sulfur from coal is an important aspect of preparation because of the role of sulfur dioxide in air pollution. Pyrite, the main inorganic sulfur mineral, is partly removed along with other minerals in conventional cleaning. Processes to improve pyrite removal are being developed. These include magnetic and electrostatic separation, chemical leaching, and specialized froth flotation.

Storage

Coal may heat spontaneously, with the likelihood of self-heating greatest among coals of lowest rank. The heating begins when freshly broken coal is exposed to air. The process accelerates with increase in temperature, and active burning will result if the heat from oxidation is not dissipated. The finer sizes of coal, having more surface area per unit weight than the larger sizes, are more susceptible to spontaneous heating.

The prevention of spontaneous heating in storage poses a problem of minimizing oxidation and of dissipating any heat produced. Air may carry away heat, but it also brings oxygen to create more heat. Spontaneous heating can be prevented or lessened by (1) storing coal underwater; (2) compressing the pile in layers, as with a road roller, to retard access of air; (3) storing large-size coal; (4) preventing any segregation of sizes in the pile; (5) storing in small piles; (6) keeping the storage pile as low as possible (6 ft is the limit for many coals); (7) keeping storage away from any external sources of heat; (8) avoiding any draft of air through the coal; (9) using older portions of the storage first and avoiding accumulations of old coal in corners. It is desirable to watch the temperature of the pile. A thermometer inserted in an iron tube driven into the coal pile will reveal the temperature. When the coal reaches a temperature of 50°C (120°F), it should be moved. Using water to put out a fire, although effective for the moment, may only delay the necessity of moving the coal. Furthermore, this may be dangerous because steam and coal can react at high temperatures to form carbon monoxide and hydrogen.

Sampling

Because coal is a heterogeneous material, collection and handling of samples that adequately represent the bulk lot of coal are required if the analytical and test data are to be meaningful. Coal is best sampled when in motion, as it is being loaded or unloaded from belt conveyors or other coal-handling equipment, by collecting increments of uniform weight evenly distributed over the entire lot. Each increment should be sufficiently large and so taken to represent properly the various sizes of the coal.

Two procedures are recognized: (1) commercial sampling and (2) special-purpose sampling, such as classification by rank or performance. The commercial sampling procedure is intended for an accuracy such that, if a large number of samples were taken from a large lot of coal, the test results in 95 out of 100 cases would fall within ± 10 percent of the ash content of these samples. For commercial sampling of lots up to 1,000 tons, it is recommended that one gross sample represent the lot taken. For lots over 1,000 tons, the following alternatives may be used: (1) Separate gross samples may be taken for each 1,000 tons of coal or fraction thereof, and a weighted average of the analytical determinations of these prepared samples may be used to represent the lot. (2) Separate gross samples may be taken for each 1,000 tons or fraction thereof, and the -20 or -60 mesh samples taken from the gross samples may be mixed together in proportion to the tonnage represented by each sample and one analysis carried out on the composite sample. (3) One gross sample may be used to represent the lot, provided that at least four times the usual minimum number of increments are taken. In special-purpose sampling, the increment requirements used in the commercial sampling procedure are increased according to prescribed rules.

Specifications

Specifications for the purchase of coal vary widely depending on the intended use, whether for coke or a particular type of combustion unit,

and whether it meets the standards imposed by customers abroad. Attempts at international standardization have met with only limited success. Most of the previously discussed factors in this section must be taken into consideration, for example, the sulfur content and swelling properties of a coal used for metallurgical coke production, the heating value of a coal used for steam generation, and the slagging properties of its ash formed after combustion.

Statistics

Coal production in 1994 was 1.03 billion short tons, 0.5 percent anthracite, 93 percent bituminous, and 6.5 percent lignite. The industry employed about 228,000 miners, 150,000 of them underground. Over 6000 coal mines are in operation in 26 states but over half the production comes from Kentucky, West Virginia, Wyoming, and Pennsylvania. Of the total production, 62 percent is from surface mines. Transportation to the point of consumption is primarily by rail (67 percent) followed by barges (11 percent) and trucks (10 percent); about 1 percent moves through pipelines. About 11 percent of the coal consumed is burned at mine-mouth power plants, for it is cheaper and easier to transport electric power than bulk coal.

Several long-distance coal-slurry pipelines are proposed but only one, 273 mi (439 km) long, is in commercial use. The Black Mesa pipeline runs from a coal mine near Kayenta, AZ to the Mohave Power Plant in Nevada. Nominal capacity is 4.8 million short tons (4.35 t) per year, but it usually operates at 3 to 4 million tons per year. The coal concentration is about 47 percent and the particle size distribution is controlled carefully. Other pipelines will be constructed where feasible and when the problems of eminent domain are resolved.

Overall energy statistics for the United States show that coal accounts for about 30 percent of the total energy production, with the balance coming from petroleum and natural gas. Below is a distribution of 1 billion tons of coal produced:

Electric power	87.2 percent
Industrial	8.4 percent
Coke	3.8 percent
Commercial and residential	0.6 percent

In 1994 over 100 million tons was exported. The industrial use is primarily for power in the production of food, cement, paper, chemicals, and ceramics.

Reserves of coal in the United States are ample for several hundred years even allowing for the increased production of electric power and the synthesis of fuels and chemicals. The total reserve base is estimated to be almost 4 million tons, of which 1.7 trillion tons is identified resources.

BIOMASS FUELS

by Martin D. Schlesinger

Wallingford Group Ltd.

REFERENCES: Peat, "U.S. Bureau of Mines Mineral Commodities Summaries." Fryling, "Combustion Engineering." Combustion Engineering, Inc., New York. "Standard Classification of Peats, Mosses, Humus and Related Products," ASTM D2607. Lowry, "Chemistry of Coal Utilization," Wiley. United Nations Industrial Development Organization publications.

Biomass conversion to energy continues to be a subject of intensive study for both developed and less developed countries. In the United States, combustion of biomass contributes only a few percent of the total U.S. energy supply, and it is mostly in the form of agricultural wastes and paper. Almost any plant material can be the raw material for gasification from which a variety of products can be created catalytically from the carbon monoxide, carbon dioxide, and hydrogen. Typical commercial products are methanol, ethanol, methyl acetate, acetic anhydride, and hydrocarbons. Alcohols are of particular interest as fuels for transportation and power generation. Producer gas has been introduced into small compression ignition engines, and the diesel oil feed

has been reduced. Technical and environmental problems are still not solved in the large-scale use of biomass.

Plants and vegetables are another source of biomass-derived oils. Fatty acid esters have been used in diesel engines alone and in blends with diesel oil, and although the esters are effective, some redesign and changes in operation are required. In developing countries where fossil fuels are costly, deforestation has led to land erosion and its consequences.

Useful biomass materials include most of the precoal organic vegetation such as peat, wood, and food processing wastes like bagasse from sugar production. Digestible food processing wastes can be converted to biogas.

Peat, an early stage in the metamorphosis of vegetable matter into coal, is the product of partial decomposition and disintegration of plant remains in water bogs, swamps or marshlands, and in the absence of air. Like all material of vegetable origin, peat is a complex mixture of carbon, hydrogen, and oxygen in a ratio similar to that of cellulose and lignin. Generally peat is low in essential growing elements (K, S, Na, P) and ash. Trace elements, when found in the peat bed, are usually introduced by leaching from adjacent strata. The Federal Trade Commission specifies that to be so labeled, peat must contain at least 75 percent peat with the rest composed of normally related soil materials. The water content of undrained peat in a bog is 92 to 95 percent but it is reduced to 10 to 50 percent when peat is used as a fuel. Peat is harvested by large earth-moving equipment from a drained bog dried by exposure to wind and sun. The most popular method used in Ireland and the Soviet Union involves harrowing of drum-cut peat and allowing it to field dry before being picked up mechanically or pneumatically.

The **chemical and physical properties of peat** vary considerably, depending on the source and the method of processing. Typical ranges are:

Processed peat	Air-Dried	Mulled	Briquettes
Moisture, wt %	25–50	50–55	10–12
Density, lb/ft ³	15–25		30–60
Caloric value, Btu/lb	6,200	3,700–5,300	8,000

Proximate analyses of samples, calculated back to a dry basis, follow a similar broad pattern: 55 to 70 percent volatile matter, 30 to 40 percent fixed carbon and 2 to 10 percent ash. The dry, ash-free ultimate analysis ranges from 53 to 63 percent carbon, 5.5 to 7 percent hydrogen, 30 to 40 percent oxygen, 0.3 to 0.5 percent sulfur, and 1.2 to 1.5 percent nitrogen.

World production of peat in 1993 was about 150 million tons, mostly from the former Soviet states. Other significant producers are Ireland, Finland, and Germany. Annual U.S. imports are primarily from Canada, about 650,000 tons per annum. Several states produce peat, Florida and Michigan being the larger producers. Over a 10-year period, U.S. production declined from 730,000 to about 620,000 short tons (590,000 t) per year. The value of production was \$16 million from 67 operations.

By type, peat was about 66 percent reed sedge with the balance distributed between humus, sphagnum, and hypnum. The main uses for peat in the United States are soil improvement, mulch, filler for fertilizers, and litter for domestic animals.

Wood, when used as a fuel, is often a by-product of the sawmill or papermaking industries. The conversion of logs to lumber results in 50 percent waste in the form of bark, shavings, and sawdust. Fresh timber contains 30 to 50 percent moisture, mostly in the cell structure of the wood, and after air drying for a year, the moisture content reduces to 18 to 25 percent. Kiln-dried wood contains about 8 percent moisture. A typical analysis range is given in Table 7.1.5. When additional fuel is required, supplemental firing of coal, oil, or gas is used.

Combustion systems for wood are generally designed specially for the material or mixture of fuels to be burned. When the moisture content is high, 70 to 80 percent, the wood must be mixed with low moisture fuel so that enough energy enters the boiler to support combustion. Dry wood may have a heating value of 8,750 Btu/lb but at 80 percent moisture a pound of wet wood has a heating value of only 1,750 Btu/lb. The heat required just to heat the fuel and evaporate the water is over 900

Table 7.1.5 Typical Analysis of Dry Wood Fuels

	Most woods, range
Proximate analysis, %:	
Volatile matter	74–82
Fixed carbon	17–23
Ash	0.5–2.2
Ultimate analysis, %:*	
Carbon	49.6–53.1
Hydrogen	5.8–6.7
Oxygen	39.8–43.8
Heating value	
Btu/lb	8,560–9,130
kJ/kg	19,900–21,250
Ash-fusion temperature, °F:	
Initial	2,650–2,760
Fluid	2,730–2,830

* Typically, wood contains no sulfur and about 0.1 percent nitrogen. Cellulose = 44.5 percent C, 6.2 percent H, 49.3 percent O.

Btu, and combustion may not occur. Table 7.1.6 shows the moisture-energy relationship. The usual practice when burning wood is to propel the wood particles into the furnace through injectors along with preheated air with the purpose of inducing high turbulence to the boiler. Furthermore, the wood is injected high enough in the combustion chamber so that it is dried, and all but the largest particles are burned before they reach the grate at the bottom of the furnace. Spreader stokers and cyclone burners work well.

Table 7.1.6 Available Energy in Wood

Moisture, %	Heating value, Btu/lb	Wt water/wt wood
0	8,750	0
20	7,000	0.25
50	4,375	1.00
80	1,750	4.00

Wood for processing or burning is usually sold by the cord, an ordered pile 8 ft long, 4 ft high, and 4 ft wide or 128 ft³ (3.625 m³). Its actual solid content is only about 70 percent, or 90 ft³. Other measures for wood are the cord run, which is measured only by the 8-ft length and 4-ft height; the width may vary. Sixteen-inch-long wood is called **stove-wood** or **blockwood**.

Small wood-burning power plants and home heating became popular, but in some areas there was an adverse environmental impact under adverse weather conditions.

Wood charcoal is made by heating wood to a high temperature in the absence of air. Wood loses up to 75 percent of its weight and 50 percent of its volume owing to the elimination of moisture and volatile matter. As a result, charcoal has a higher heating value per cubic foot than the original wood, especially if the final product is compacted in the form of briquettes. Charcoal is marketed in the form of lumps, powder, or briquettes and finds some use as a fuel for curing, restaurant cooking, and a picnic fuel. Its nonfuel uses, particularly in the chemical industry, are as an adsorption medium for purifying gas and liquid streams and as a decolorizing agent.

In addition to peat and wood, several lesser-known fuels are in common use for the generation of industrial steam and power. Aside from their value as a fuel, the burning of wastes minimizes a troublesome disposal problem that could have serious environmental impact. Nearly all these waste fuels are cellulosic in character, and the heating value is a function of the carbon content. Ash content is generally low, but much moisture could be present from processing, handling, and storage. On a moisture- and ash-free basis the heating values can be estimated at 8,000 Btu/lb; more resinous materials about 9,000 Btu/lb. Table 7.1.7 is a list of some typical by-product solid fuels.

Table 7.1.7 By-product Fuels

	Heating value, Btu/lb (dry)	Moisture, % as received	Ash, % moisture-free
Black liquor (sulfate)	6,500	35	40–45
Cattle manure	7,400	50–75	17
Coffee grounds	10,000	65	1.5
Corn cobs	9,300	10	1.5
Cottonseed cake	9,500	10	8
Municipal refuse	9,500	43	8
Pine bark	9,500	40–50	5–10
Rice straw or hulls	6,000	7	15
Scrap tires	16,400	0.5	6
Wheat straw	8,500	10	4

Bagasse is the fibrous material left after pressing the juice from sugarcane or harvesting the seeds from sunflowers. The chopped waste usually contains about 50 percent moisture and is burned in much the same manner as wood waste. Spreader stokers or cyclone burners are used. Supplemental fuel is added sometimes to maintain steady combustion and to provide energy for the elimination of moisture. Bagasse can usually supply all the fuel requirements of raw sugar mills. A typical analysis of dry bagasse from Puerto Rico is 44.47 percent C, 6.3 percent H, 49.7 percent O, and 1.4 percent ash. Its heating value is 8,390 Btu/lb.

Furnaces have been developed to burn particular wastes, and some preferences emerge by virtue of particular operating characteristics. Spreader stokers are preferred for wood waste and bagasse. Tangential firing seems to be used for coffee grounds, rice hulls, some wood waste, and chars from coal or lignite. Traveling-grate stokers are used for industrial wastes and coke breeze.

Biogas is readily produced by the anaerobic digestion of wastes. The process is cost-effective in areas remote from natural gas lines. In Asia, for example, there are millions of family biodigesters with a capacity of 8 to 10 m³. Larger-capacity systems of about 2,000 m³ are installed where industrial biodegradable wastes are generated as in communes, feed lots, wineries, food processors, etc. Not only is the gas useful, but also the sludge is a good fertilizer. Remaining parasite eggs and bacteria are destroyed by lime or ammonia treatment. Harvest increases of 10 to 35 percent are reported for rice and corn.

Biogas contains an average of 62 percent methane and 36 percent carbon dioxide; it also has a small amount of nitrogen and hydrogen sulfide. Raw gas heating value is about 600 Btu/ft³ (5,340 cal/m³). The raw gas will burn in an engine, but corrosion can occur unless proper materials of construction are selected. Gas from a garbage site in California is treated to remove acid gases, and the methane is sold to a pipeline system. Most sites, however, do not produce enough gas to use economically and merely flare the collected gas.

Other methods have been demonstrated for converting biomass of variable composition to an energy source of relatively consistent composition. One procedure is to process bulk volume wastes with pressurized carbon monoxide. A yield of about 2 barrels of oil per ton of dry feed is obtained, with a heating value of about 15,000 Btu/lb. Heavy fuel oil from petroleum has a heating value of 18,000 Btu/lb. Pyrolysis is also possible at temperatures up to 1,000°C in the absence of air. The gas produced has a heating value of 400 to 500 Btu/ft³ (about 4,000 kcal/m³). The oil formed has a heating value about 10,500 Btu/lb (24,400 J/g).

Refuse-derived fuels (RDFs) usually refer to waste material that has been converted to a fuel of consistent composition for commercial application. Although several sources exist, the problem lies in gathering the raw material, processing it into a usable form and composition, and delivering it to the point of combustion. Almost any carbonaceous material and a suitable binder can be converted to a form that can be fired into a pulverized fuel or a stoker boiler. Each application should be evaluated to eliminate carryover of low-density material, such as loose paper, and where in the boiler that combustion takes place.

Some installations are cofired with fossil fuels. Most of the by-

product fuels in Table 7.1.7 might be used alone or with a binder. An ideal situation would be nearby waste streams from a major production facility. After mixing and extrusion, the pellets would be storable and transported only a short distance. If the pellet density is close to the normal boiler feed, the problems of separation during transportation and firing are reduced or eliminated. The problem of hazardous emissions remains if the waste streams are contaminated; if they are clean-burning, hazardous emissions might reduce the apparent cleanliness of the effluent. (See Sec. 7.4.)

PETROLEUM AND OTHER LIQUID FUELS

by James G. Speight

Western Research Institute

REFERENCES: ASTM, "Annual Book of ASTM Standards," 1993, vols. 05.01, 05.02, 05.03, and 05.04. Bland and Davidson, "Petroleum Processing Handbook," McGraw-Hill, New York. Gary and Handwerk, "Petroleum Refining: Technology and Economics," Marcel Dekker, New York. Hobson and Pohl, "Modern Petroleum Technology," Applied Science Publishers, Barking, England. Mushrush and Speight, "Petroleum Products: Instability and Incompatibility," Taylor & Francis, Washington. Speight, "The Chemistry and Technology of Petroleum," 2d ed., Marcel Dekker, New York.

Petroleum and Petroleum Products

Petroleum accumulates over geological time in porous underground rock formations called reservoirs, where it has been trapped by overlying and adjacent impermeable rock. Oil reservoirs sometimes exist with an overlying gas "cap" in communication with aquifers or with both. The oil resides together with water, and sometimes free gas, in very small holes (pore spaces) and fractures. The size, shape, and degree of interconnection of the pores vary considerably from place to place in an individual reservoir. The anatomy of a reservoir is complex, both microscopically and macroscopically. Because of the various types of accumulations and the existence of wide ranges of both rock and fluid properties, reservoirs respond differently and must be treated individually.

Petroleum occurs throughout the world, and commercial fields have been located on every continent. Reservoir depths vary, but most reservoirs are several thousand feet deep, and the oil is produced through wells that are drilled to penetrate the oil-bearing formations.

Petroleum is an extremely complex mixture and consists predominantly of hydrocarbons as well as compounds containing nitrogen, oxygen, and sulfur. Most petroleum also contains minor amounts of nickel and vanadium.

Petroleum may be qualitatively described as brownish green to black liquids of specific gravity from about 0.810 to 0.985 and having a boiling range from about 20°C (68°F) to above 350°C (660°F), above which active decomposition ensues when distillation is attempted. The oils contain from 0 to 35 percent or more of components boiling in the gasoline range, as well as varying proportions of kerosene hydrocarbons and higher-boiling-point constituents up to the viscous and nonvolatile compounds present in lubricants and the asphalts. The composition of the petroleum obtained from the well is variable and depends on both the original composition of the petroleum in situ and the manner of production and stage reached in the life of the well or reservoir.

The chemical and physical properties of petroleum vary considerably because of the variations in composition. The specific gravity of petroleum ranges from 0.8 (45.3 degrees API) for the lighter crude oils to over 1 (< 10 degrees API) for the near-solid bitumens which are found in many tar (oil) sand deposits. There is also considerable variation in viscosity; lighter crude oils range from 2 to 100 cSt, bitumens have viscosities in excess of 50,000 cSt.

The ultimate analysis (elemental composition) of petroleum is not reported to the same extent as it is for coal since there is a tendency for the ultimate composition of petroleum to vary over narrower limits—carbon: 83.0 to 87.0 percent; hydrogen: 10.0 to 14.0 percent; nitrogen: 0.1 to 1.5 percent; oxygen: 0.1 to 1.5 percent; sulfur: 0.1 to 5.0 percent; metals (nickel plus vanadium): 10 to 500 ppm. The **heat content of petro-**

Table 7.1.8 Analyses and Heat Values of Petroleum and Petroleum Products

Product	Gravity, deg API	Specific gravity at 60°F	Wt lb/gal	High-heat value, Btu/lb*	Ultimate analysis, %				
					C	H	S	N	O
California crude	22.8	0.917	7.636	18,910	84.00	12.70	0.75	1.70	1.20
Kansas crude	22.1	0.921	7.670	19,130	84.15	13.00	1.90	0.45	
Oklahoma crude (east)	31.3	0.869	7.236	19,502	85.70	13.11	0.40	0.30	
Oklahoma crude (west)	31.0	0.871	7.253	19,486	85.00	12.90	0.76		
Pennsylvania crude	42.6	0.813	6.769	19,505	86.06	13.88	0.06	0.00	0.00
Texas crude	30.2	0.875	7.286	19,460	85.05	12.30	1.75	0.70	0.00
Wyoming crude	31.5	0.868	7.228	19,510					
Mexican crude	13.6	0.975	8.120	18,755	83.70	10.20	4.15		
Gasoline	67.0	0.713	5.935	84.3	15.7			
Gasoline	60.0	0.739	6.152	20,750	84.90	14.76	0.08		
Gasoline-benzene blend	46.3	0.796	6.627	88.3	11.7			
Kerosene	41.3	0.819	6.819	19,810					
Gas oil	32.5	0.863	7.186	19,200					
Fuel oil (Mex.)	11.9	0.987	8.220	18,510	84.02	10.06	4.93		
Fuel oil (midcontinent)	27.1	0.892	7.428	19,376	85.62	11.98	0.35	0.50	0.60
Fuel oil (Calif.)	16.7	0.9554	7.956	18,835	84.67	12.36	1.16		

* Btu/lb × 2.328 = kJ/kg.

leum generally varies from 18,000 to 20,000 Btu/lb while the heat content of petroleum products may exceed 20,000 Btu/lb (Table 7.1.8).

Refining Crude Oil Crude oils are seldom used as fuel because they are more valuable when refined to petroleum products. Distillation separates the crude oil into fractions equivalent in boiling range to gasoline, kerosene, gas oil, lubricating oil, and residual. Thermal or catalytic cracking is used to convert kerosene, gas oil, or residual to gasoline, lower-boiling fractions, and a residual coke. Catalytic reforming, isomerization, alkylation, polymerization, hydrogenation, and combinations of these catalytic processes are used to upgrade the various refinery intermediates into improved gasoline stocks or distillates. The major finished products are usually blends of a number of stocks, plus additives. Distillation curves for these products are shown in Fig. 7.1.2.

Physical Properties of Petroleum Products Petroleum products are sold in the United States by barrels of 42 gal corrected to 60°F, Table 7.1.9. Their *specific gravity* is expressed on an arbitrary scale termed degrees API.

The **high heat value** (hhv) of petroleum products is determined by combustion in a bomb with oxygen under pressure (ASTM D240). It may also be calculated, in products free from impurities, but the formula

$$Q_v = 22,320 - 3,780d^2$$

in which Q_v is the hhv at constant volume in Btu/lb and d is the specific gravity at 60/60°F.

The low heat value at constant pressure Q_p may be calculated by the relation

$$Q_p = Q_v - 90.8H$$

where H is the weight percentage of hydrogen and can be obtained from the relation

$$H = 26 - 15d$$

Typical heats of combustion of petroleum oils free from water, ash, and sulfur vary (within an estimated accuracy of 1 percent) with the API gravity (i.e., with the "heaviness" or "lightness" of the material) (Table 7.1.10). The heat value should be corrected when the oil contains sulfur by using an hhv of 4,050 Btu/lb for sulfur (ASTM D1405).

The **specific heat** c of petroleum products of specific gravity d and at temperature t (°F) is given by the equation

$$c = (0.388 + 0.00045t)/\sqrt{d}$$

The **heat of vaporization** L (Btu/lb) may be calculated from the equation

$$L = (110.9 - 0.09t)/d$$

The heat of vaporization per gallon (measured at 60°F) is

$$8.34Ld = 925 - 0.75t$$

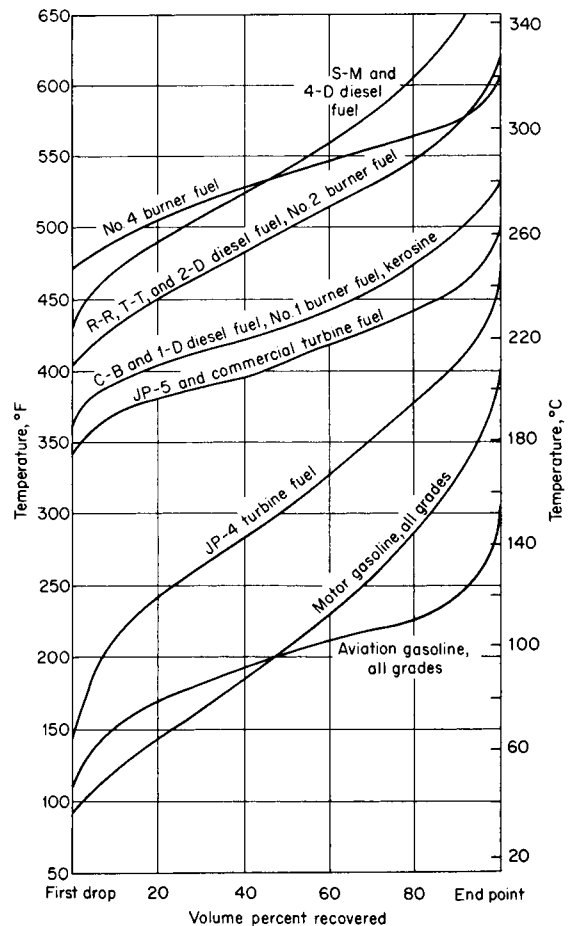

Fig. 7.1.2 Typical distillation curves.

indicating that the heat of vaporization per gallon depends only on the temperature of vaporization t and varies over the range of 450 for the heavier products to 715 for gasoline (Table 7.1.11). These data have an estimated accuracy within 10 percent when the vaporization is at constant temperature and at pressures below 50 lb/in² without chemical change.

Table 7.1.9 Coefficients of Expansion of Petroleum Products at 60°F

Deg API	< 15	15–34.9	35–50.9	51–63.9	64–78.9	79–88.9	89–93.9	94–100
Coef of expansion	0.00035	0.0004	0.0005	0.0006	0.0007	0.0008	0.00085	0.0009

Table 7.1.10 Heat Content of Different Petroleum and Petroleum Products

Deg API at 60°F	Density, lb/gal*	High heat value at constant volume Q_v , Btu		Low heat value at constant pressure Q_p , Btu	
		Per lb	Per gal	Per lb	Per gal
10	8.337	18,540	154,600	17,540	146,200
20	7.787	19,020	148,100	17,930	139,600
30	7.305	19,420	141,800	18,250	133,300
40	6.879	19,750	135,800	18,510	127,300
50	6.500	20,020	130,100	18,720	121,700
60	6.160	20,260	124,800	18,900	116,400
70	5.855	20,460	119,800	19,020	112,500
80	5.578	20,630	115,100	19,180	107,000

* Btu/lb \times 2.328 = kJ/kg; Btu/gal \times 279 = kJ/m³.

Table 7.1.11 Latent Heat of Vaporization of Petroleum Products

Product	Gravity, deg API	Average boiling temp, °F	Heat of vaporization	
			Btu/lb	Btu/gal
Gasoline	60	280	116	715
Naphtha	50	340	103	670
Kerosine	40	440	86	595
Fuel oil	30	580	67	490

Properties and Specifications for Motor Gasoline

Gasoline is a complex mixture of hydrocarbons that distills within the range of 100 to 400°F. Commercial gasolines are blends of straight-run, cracked, reformed, and natural gasolines.

Straight-run gasoline is recovered from crude petroleum by distillation and contains a large proportion of normal hydrocarbons of the paraffin series. Its octane number is too low for use in modern engines, and it is reformed and blended with other products to improve its combustion properties.

Cracked gasoline is manufactured by heating crude-petroleum distillation fractions or residues under pressure, or by heating with or without pressure in the presence of a catalyst. Heavier hydrocarbons are broken into smaller molecules, some of which distill in the gasoline range. The octane number of cracked gasoline is usually above that of straight-run gasoline.

Reformed gasoline is made by passing gasoline fractions over catalysts in such a manner that low-octane-number hydrocarbons are molecularly rearranged to high-octane-number components. Many of the catalysts use platinum and other metals deposited on a silica and/or alumina support.

Natural gasoline is obtained from natural gas by liquefying those constituents which boil in the gasoline range either by compression and cooling or by absorption in oil. Natural gasoline is too volatile for general use, but proper characteristics can be secured by distillation or by blending. It is often blended with gasolines to adjust their volatility characteristics to meet climatic conditions.

Catalytic hydrogenation is used extensively to upgrade gasoline and cracking stocks for blending or further refining. Hydrogenation improves octane number, removes sulfur and nitrogen, and increases storage stability.

The specifications for gasoline (ASTM D439) provide for various volatility classes, varying from low-volatility gasolines to minimize vapor lock to high-volatility gasoline that permits easier starting during cold weather.

Antiknock characteristics of gasolines are very important because engine power output and fuel economy are limited by the antiknock characteristics of the fuel. The antiknock index is currently defined as the average of the research octane number (RON) and motor octane number (MON). The **research octane number** is a measure of antiknock performance under mild operating conditions at low to medium engine speeds. The **motor octane number** is indicative of antiknock performance under more severe conditions, such as those encountered during power acceleration at relatively high engine speeds.

Reformulated motor gasoline is believed to be the answer to many environmental issues that arise from the use of automobiles. In fact, there has been a serious effort to produce reformulated gasoline components from a variety of processes (Table 7.1.12). In addition, methyl-*t*-butyl ether (MTBE), an additive to maintain the octane ratings of gasoline in the absence of added lead, is claimed to reduce (through more efficient combustion of the hydrocarbons) the emissions of unburned hydrocarbons during gasoline use. However, the ether (MTBE) is believed to have an adverse effect insofar as it appears that aldehyde emissions may be increased.

Table 7.1.12 Production of Reformulated Gasoline Constituents

Process	Objective
Catalytic reformer prefractionation	Reduce benzene
Reformate fractionation	Reduce benzene
Isomerization	Increase octane
Aromatics saturation	Reduce total aromatics
Catalytic reforming	Oxygenate for octane enhancement
MTBE synthesis	Provide oxygenates
Isobutane dehydrogenation	Feedstock for oxygenate synthesis
Catalytic cracker naphtha fractionation	Increase alkylate
	Increase oxygenates
	Reduce olefins and sulfur
Feedstock hydrotreating	Reduce sulfur

Diesel Fuel

Diesel is a liquid product distilling over the range of 150 to 400°C (300 to 750°F). The carbon number ranges on average from about C₁₃ to about C₂₁.

The chemical composition of a typical diesel fuel and how it applies to the individual specifications—API gravity, distillation range, freezing point, and flash point—are directly attributable to both the carbon number and the compound classes present in the finished fuel (Tables 7.1.13 and 7.1.14).

Aviation Gasolines Gasolines for aircraft piston engines have a

Table 7.1.13 General ASTM Specifications for Various Types of Diesel Fuels

Specification	Military*	No. 1-D†	No. 2-D‡	No. 1§	No. 2¶
API gravity, deg	40	34.4	40.1	35	30
Total sulfur, percent	0.5	0.5	0.5	0.5	0.5
Boiling point, °C	357	288	338	288	338
Flash point, °C	60	38	52	38	38
Pour point, °C	-6	-18	-6	-18	-6
Hydrogen, wt %	12.5	—	—	—	—
Cetane number	43	40	40	—	—
Acid number	0.3	0.3	0.3	—	—

* MIL-F-16884J (1993) is also NATO F-76.

† High-speed, high-load engines.

‡ Low-speed, high-load engines.

§ Special-purpose burners.

¶ General-purpose heating fuel oil.

narrower boiling range than motor gasolines; i.e., they have fewer low-boiling and fewer high-boiling components. The three grades of aviation gasolines are indicated in Table 7.1.15. Specifications applicable to all three grades of military gasoline are given in Table 7.1.16.

Table 7.1.14 ASTM Methods for Determining Fuel Properties (see also Table 7.1.13)

Specification	ASTM method
API gravity	D1298
Total sulfur, percent	D129
Boiling point, °C	D86
Flash point, °C	D93
Pour point, °C	D97
Hydrogen, wt %	D3701
Cetane number	D613, D976
Acid number	D974

Jet or aviation turbine fuels are not limited by antiknock requirements, and they have wider boiling-point ranges to provide greater availability (ASTM D1655). Fuel JP-4 is a relatively wide-boiling-point range distillate that encompasses the boiling point range of gasoline and kerosene. The average initial boiling point is about 140°F, and the endpoint is about 455°F. Fuel JP-5 is a high-flash point kerosine type of fuel with an initial boiling point of 346°F and endpoint of 490°F.

Table 7.1.15 Grades of Aviation Gasoline (ASTM D910)

Grade	Color	Tetraethyl lead content mL/gal, max
80	Red	0.6
100	Green	4.0
100 LL	Blue	2.0

There are a variety of grades (Table 7.1.15) and specifications (Table 7.1.16) for jet fuel because of its use as a commercial and a military fuel (Table 7.1.17). The chemical composition of each jet fuel type, API gravity, distillation range, freezing point, and flash point are directly attributable to both the carbon number and the compound classes present in the finished fuel.

Table 7.1.16 Specifications for Aviation Gasoline

Test	Test limit	Test method
Distillation:		
Fuel evaporated, 10% min at	167°F (75°C)	D86
Fuel evaporated, 40% max at	167°F (75°C)	
Fuel evaporated, 50% min at	221°F (105°C)	
Fuel evaporated, 90% min at	275°F (135°C)	
Endpoint, max	338°F (170°C)	
Sum of 10% and 50% evaporated temp, min	307°F	
Residue, vol, max %	1.5	
Distillation loss, vol, max %	1.5	
Existent gum, max, mg/100 mL	3.0	D381
Potential gum, 16 h aging, max, mg/100 mL	6.0	D873
Precipitate, max, mg/100 mL	2.0	D873
Sulfur, max, wt %	0.05	D1266 or D2622
Reid vapor pressure at 100°F, min, lb/in ²	5.5	D323
Reid vapor pressure at 100°F, max, lb/in ²	7.0	D323
Freezing point, max	-76°F (-60°C)	D2386
Copper corrosion, max	No. 1	D130
Water reaction:		
Interface rating, max	2	D1094
Vol. change, max, mL	2	D1094
Heating value:		
Net heat of combustion, min, Btu/lb	18,700	D1405
Aniline-gravity product, min	7,500	D611 and D287

Kerosine is less volatile than gasoline and has a higher flash point, to provide greater safety in handling. Other quality tests are specific gravity, color, odor, distillation range, sulfur content, and burning quality. Most kerosine is used for heating, ranges, and illumination, so it is treated with sulfuric acid to reduce the content of aromatics, which burn

Table 7.1.17 Commercial and Military Specifications for Jet Fuels

Fuel types	Specification
Jet-A	ASTM D1655
JP-4	Mil-T-5624
JP-5	Mil-T-5624
JP-8	Mil-T-83133
JP-10	Mil-P-87107

with a smoky flame. Specification tests for quality control include flash point (minimum 115°F), distillation endpoint (maximum 572°F), sulfur (maximum 0.13 percent), and color (minimum + 16) (ASTM D187).

Diesel fuel for diesel engines requires variability in its performance since the engines range from small, high-speed engines used in trucks and buses to large, low-speed stationary engines for power plants. Thus several grades of diesel fuel are needed (Table 7.1.18) (ASTM D975) for different classes of service:

Grade 1-D: A volatile distillate fuel for engines in service requiring frequent speed and load changes

Grade 2-D: A distillate fuel of lower volatility for engines in industrial and heavy mobile service

Grade 4-D: A fuel for low- and medium-speed engines

An additional guide to fuel selection is the grouping of fuels according to these types of service:

Type C-B: Diesel fuel oils for city bus and similar operations

Type T-T: Fuels for diesel engines in trucks, tractors, and similar service

Type R-R: Fuels for railroad diesel engines

Type S-M: Heavy-distillate and residual fuels for large stationary and marine diesel engines

The combustion characteristics of diesel fuels are expressed in terms of the cetane number, a measure of ignition delay. A short ignition

Table 7.1.18 Specifications* for Diesel Fuels

Test	ASTM method	ASTM grade of diesel fuel			U.S. Military spec. Mil-F-16884G
		1-D	2-D	4-D	
Flash point, min, °F	D93	100 or legal	125 or legal	130 or legal	140
Water and sediment, vol %, max	D1796	Trace	0.10	0.50	
Viscosity, kinematic, cSt, 100°F	D445				
Min		1.3	1.9	5.5	1.8
Max		2.4	4.1	24.0	4.5
Carbon residue on 10% residuum, % max	D524	015	0.35		0.20
Ash, wt %, max	D482	0.01	0.01	0.10	0.005
Sulfur, wt %, max	D129	0.50	0.50	2.0	1.00
Ignition quality, cetane number, min	D613	40	40	30	45
Distillation temp, °F, 90% evaporated:	D86				
Min			540		
Max		550	640		

* See ASTM D975 and Mil-F-16884G specifications for full details.

delay, i.e., the time between injection and ignition, is desirable for a smooth-running engine. Some diesel fuels contain cetane improvers, which usually are alkyl nitrates. The cetane number is determined by an engine test (ASTM D613) or an approximate value, termed the **cetane index** (ASTM D976), can be calculated for fuels that do not contain cetane improvers.

The list of additives used in diesel fuels has grown in recent years because of the increased use of catalytically cracked fuels, rather than exclusively straight-run distillate. In addition to cetane improvers, the list includes antioxidants, corrosion inhibitors, and dispersants. The dispersants are added to prevent agglomeration of gum or sludge deposits so these deposits can pass through filters, injectors, and engine parts without plugging them.

Gas-Turbine Fuels

Five grades of gas-turbine fuels are specified (ASTM D2880) according to the types of service and engine:

Grade O-GT: A naphtha or other low-flash-point hydrocarbon liquid which also includes jet B fuel

Grade 1-GT: A volatile distillate for gas turbines that requires a fuel that burns cleaner than grade 2-GT

Grade 2-GT: A distillate fuel of low ash and medium volatility, suitable for turbines not requiring grade 1-GT

Grade 3-GT: A low-volatility, low-ash fuel that may contain residual components

Grade 4-GT: A low-volatility fuel containing residual components and having higher vanadium content than grade 3-GT

Grade 1-GT corresponds in physical properties to no. 1 burner fuel and grade 1-D diesel fuel. Grade 2-GT corresponds in physical properties to no. 2 burner fuel and grade 2-D diesel fuel. The viscosity ranges of grades 3-GT and 4-GT bracket the viscosity ranges of no. 4, no. 5 light, no. 5 heavy, and no. 6 burner fuels.

Fuel Oils

The characteristics of the grades of fuel oil (ASTM D396) are as follows:

No. 1: A distillate oil intended for vaporizing pot-type burners and other burners requiring this grade of fuel.

No. 2: A distillate oil for general-purpose domestic heating in burners not requiring no. 1 fuel oil.

No. 4 and no. 4 light: Preheating not usually required for handling or burning.

No. 5 light: Preheating may be required depending upon climate and equipment.

No. 5 heavy: Preheating may be required for burning and, in cold climates, may be required for handling.

No. 6: Preheating required for burning and handling.

The sulfur content of no. 1 and no. 2 fuel oil is limited to 0.5 percent

the legal requirements of the locality in which they are to be used. The additional refinery processing needed by some residual fuels to meet low-sulfur-content regulations may lower the viscosity enough to cause the fuels to change the grade classification.

Fuel oil used for domestic purposes or for small heating installations will have lower viscosities and lower sulfur content. In large-scale industrial boilers, heavier-grade fuel oil is used with sulfur content (ASTM D129 and D1552) requirements regulated according to the environmental situation of each installation and the local environmental regulations.

The **flash point** (ASTM D93) is usually limited to 60°C (140°F) minimum because of safety considerations. Asphaltene content (ASTM D3279), carbon residue value (ASTM D189 and D524), ash (ASTM D482), water content (ASTM D95), and metal content requirements are included in some specifications.

The **pour point** (ASTM D97), indicating the lowest temperature at which the fuel will retain its fluidity, is limited in the various specifications according to local requirements and fuel-handling facilities. The upper limit is sometimes 10°C (50°F), in warm climates somewhat higher.

Another important specification requirement is the heat of combustion (ASTM D240). Usually, specified values are 10,000 cal/kg (gross) or 9,400 cal/kg (net).

Because of economic considerations residual fuel oil has been replacing diesel fuel for marine purposes. Viscosity specifications had to be adjusted to the particular operational use, and some additional quality requirements had to be allowed for. The main problem encountered during the use of residual fuel oils for marine purposes concerns the stability properties (sludge formation) and even more so the compatibility properties of the fuel.

Blending of fuel oils to obtain lower viscosity values and to mix fuel oils of different chemical characteristics is a source of deposit and sludge formation in the vessel fuel systems. This incompatibility is mainly observed when high-asphaltene fuel oils are blended with diluents or other fuel oils of a paraffinic nature.

Gas oil is a general term applied to distillates boiling between kerosine and lubricating oils. The name was derived from its initial use for making illuminating gas, but it is now used as burner fuel, diesel fuel, and catalytic-cracker charge stock.

GASEOUS FUELS

by James G. Speight

Western Research Institute

REFERENCES: Bland and Davidson, "Petroleum Processing Handbook," McGraw-Hill, New York. Francis and Peters, "Fuels and Fuel Technology," 2d ed., Pergamon, New York, Sec. C, Gaseous Fuels. Goodger, "Alternative Fuels: Chemical Energy Resources," Wiley, New York. Kohl and Riesenfeld, "Gas Purification," Gulf Publishing Co., Houston, TX. Kumar, "Gas Production Engi-

Table 7.1.19 Composition of Natural Gases*

Sample no.	Natural gas from oil or gas wells						Natural gas from pipelines				
	299	318	393	522	732	1177	1214	1225	1249	1276	1358
Composition, mole percent:											
Methane	92.1	96.3	67.7	63.2	43.6	96.9	94.3	72.3	88.9	75.4	85.6
Ethane	3.8	0.1	5.6	3.1	18.3	1.7	2.1	5.9	6.3	6.4	7.8
Propane	1.0	0.0	3.1	1.7	14.2	0.3	0.4	2.7	1.8	3.6	1.4
Normal butane	0.3	0.0	1.5	0.5	8.6	0.1	0.2	0.3	0.2	1.0	0.0
Isobutane	0.3	0.0	1.2	0.4	2.3	0.0	0.0	0.2	0.1	0.6	0.1
Normal pentane	0.1	0.0	0.6	0.1	2.7	0.3	Tr	Tr	0.0	0.1	0.0
Isopentane	Tr	0.0	0.4	0.2	3.3	0.0	Tr	0.2	Tr	0.2	0.1
Cyclopentane	Tr	0.0	0.2	Tr	0.9	Tr	Tr	0.0	Tr	Tr	0.0
Hexanes plus	0.2	0.0	0.7	0.1	2.0	0.1	Tr	Tr	Tr	0.1	Tr
Nitrogen	0.9	1.0	17.4	27.9	3.0	0.6	0.0	17.8	2.2	12.0	4.7
Oxygen	0.2	0.0	Tr	0.1	0.5	Tr	Tr	Tr	Tr	Tr	Tr
Argon	Tr	Tr	0.1	0.1	Tr	0.0	0.0	Tr	0.0	Tr	Tr
Hydrogen	0.0	0.2	0.0	0.0	0.1	0.0	Tr	0.1	0.1	0.0	0.0
Carbon dioxide	1.1	2.3	0.1	0.4	0.5	0.0	2.8	0.1	0.1	0.1	0.2
Helium	Tr	Tr	1.4	2.1	Tr	Tr	Tr	0.4	0.1	0.4	0.1
Heating value†	1,062	978	1,044	788	1,899	1,041	1,010	934	1,071	1,044	1,051
Origin of sample	La.	Miss.	N. Mex.	Okla.	Tex.	W. Va.	Colo.	Kan.	Kan.	Okla.	Tex.

* Analyses from *BuMines Bull.* 617 (Tr = trace).

† Calculated total (gross) Btu/ft³, dry, at 60°F and 30 in Hg.

ties of Gases and Liquids," McGraw-Hill. Shekhtman, "Gasdynamic Functions of Real Gases," Hemisphere Publishing Corp., Washington. Speight, "Fuel Science and Technology Handbook," J. G. Speight, ed., Marcel Dekker, New York, pt. 5, pp. 1055 et seq. Speight, "Gas Processing: Environmental Aspects and Methods," Butterworth-Heinemann, Oxford, England. Sychev et al., "Thermodynamic Properties of Propane," Hemisphere Publishing Corp.

Natural gas, which is predominantly methane, occurs in underground reservoirs separately or in association with crude petroleum. But **manufactured gas** is a fuel-gas mixture made from other solid, liquid, or gaseous materials, such as coal, coke, oil, or natural gas. The principal types of manufactured gas are retort coal gas, coke oven gas, water gas, carbureted water gas, producer gas, oil gas, reformed natural gas, and reformed propane or liquefied petroleum gas (LPG). Several processes for making substitute natural gas (SNG) from coal have been developed. **Mixed gas** is a gas prepared by adding natural gas or liquefied petroleum gas to a manufactured gas, giving a product with better utility and higher heat content or Btu value.

Liquefied petroleum gas (LPG) is the term applied to certain specific hydrocarbons and their mixtures, which exist in the gaseous state under atmospheric ambient conditions but can be converted to the liquid state under conditions of moderate pressure at ambient temperature. Thus liquefied petroleum gas is a hydrocarbon mixture usually containing propane (CH₃.CH₂.CH₃), *n*-butane (CH₃.CH₂.CH₂.CH₃), isobutane [CH₃CH(CH₃)CH₃], and to a lesser extent propylene (CH₃.CH:CH₂) or butylene (CH₃CH₂CH:CH₂). The most common commercial products are propane, butane, or some mixture of the two, and they are generally extracted from natural gas or crude petroleum. Propylene

and butylenes result from cracking other hydrocarbons in a petroleum refinery and are two important chemical feedstocks.

Composition of Gaseous Fuels The principal constituent of natural gas is methane (CH₄) (Table 7.1.19). Other constituents are paraffinic hydrocarbons such as ethane, propane, and the butanes. Many natural gases contain nitrogen as well as carbon dioxide and hydrogen sulfide. Trace quantities of argon, hydrogen, and helium may also be present. A portion of the heavier hydrocarbons, carbon dioxide, and hydrogen sulfide are removed from natural gas prior to its use as a fuel. Typical natural-gas analyses are given in Table 7.1.19. Manufactured gases contain methane, ethane, ethylene, propylene, hydrogen, carbon monoxide, carbon dioxide, and nitrogen, with low concentrations of water vapor, oxygen, and other gases.

Specifications Since the composition of natural, manufactured, and mixed gases can vary so widely, no single set of specifications could cover all situations. The requirements are usually based on performances in burners and equipment, on minimum heat content, and on maximum sulfur content. Gas utilities in most states come under the supervision of state commissions or regulatory bodies, and the utilities must provide a gas that is acceptable to all types of consumers and that will give satisfactory performance in all kinds of consuming equipment.

Specifications for liquefied petroleum gases (Table 7.1.20) (ASTM D1835) depend upon the required volatility.

Odorization Since natural gas as delivered to pipelines has practically no odor, the addition of an odorant is required by most regulations in order that the presence of the gas can be detected readily in case of accidents and leaks. This odorization is provided by the addition of trace amounts of some organic sulfur compounds to the gas before it reaches

Table 7.1.20 Specifications* for Liquefied Petroleum Gas

	Product designation			Test method
	Propane	Butane	PB mixtures	
Vapor pressure at 100°F, max, psig	210	70		D1267 or D2598
Volatile residue:				
Butane and heavier, %, max	2.5			D2163
Pertane and heavier, %, max		2.0	2.0	D2163
Residual matter:				
Residue on evaporation, + 100 mL, max mL	0.05	0.05	0.05	D2158
Oil-stain observation	Pass	Pass	Pass	D2158
Specific gravity at 60°/60°F		To be reported		D1657 or D2598
Corrosion, copper strip, max	No. 1	No. 1	No. 1	D1838
Sulfur, grains/100 ft ³ , max	15	15	15	D1266
Moisture content		To be reported		
Free-water content		None	None	D1657

the consumer. The standard requirement is that a user will be able to detect the presence of the gas by odor when the concentration reaches 1 percent of gas in air. Since the lower limit of flammability of natural gas is approximately 5 percent, this 1 percent requirement is essentially equivalent to one-fifth the lower limit of flammability. The combustion of these trace amounts of odorant does not create any serious problems of sulfur content or toxicity.

Analysis

The different methods for gas analysis include absorption, distillation, combustion, mass spectroscopy, infrared spectroscopy, and gas chromatography (ASTM D2163, D2650, and D4424). Absorption methods involve absorbing individual constituents one at a time in suitable solvents and recording of contraction in volume measured. Distillation methods depend on the separation of constituents by fractional distillation and measurement of the volumes distilled. In combustion methods, certain combustible elements are caused to burn to carbon dioxide and water, and the volume changes are used to calculate composition. Infrared spectroscopy is useful in particular applications. For the most accurate analyses, mass spectroscopy and gas chromatography are the preferred methods.

ASTM has adopted a number of methods for gas analysis, including ASTM D2650, D2163, and D1717.

Physical Constants The specific gravity of gases, including LP gases, may be determined conveniently by a number of methods and a variety of instruments (ASTM D1070 and D4891).

The heat value of gases is generally determined at constant pressure in a flow calorimeter in which the heat released by the combustion of a definite quantity of gas is absorbed by a measured quantity of water or air. A continuous recording calorimeter is available for measuring heat values of natural gases (ASTM D1826).

Flammability The lower and upper limits of flammability indicate the percentage of combustible gas in air below which and above which flame will not propagate. When flame is initiated in mixtures having compositions within these limits, it will propagate and therefore the mixtures are flammable. A knowledge of flammable limits and their use in establishing safe practices in handling gaseous fuels is important, e.g., when purging equipment used in gas service, in controlling factory or mine atmospheres, or in handling liquefied gases.

Many factors enter into the experimental determination of flammable limits of gas mixtures, including the diameter and length of the tube or vessel used for the test, the temperature and pressure of the gases, and the direction of flame propagation—upward or downward. For these and other reasons, great care must be used in the application of the data. In monitoring closed spaces where small amounts of gases enter the atmosphere, often the maximum concentration of the combustible gas is limited to one fifth of the concentration of the gas at the lower limit of flammability of the gas-air mixture. (See Table 7.1.21.)

The calculation of flammable limits is accomplished by Le Chatelier's modification of the mixture law, which is expressed in its simplest form as

$$L = \frac{100}{p_1/N_1 + p_2/N_2 + \dots + p_n/N_n}$$

where L is the volume percentage of fuel gas in a limited mixture of air and gas; p_1, p_2, \dots, p_n are the volume percentages of each combustible gas present in the fuel gas, calculated on an air- and inert-free basis so that $p_1 + p_2 + \dots + p_n = 100$; and N_1, N_2, \dots, N_n are the volume percentages of each combustible gas in a limit mixture of the individual gas and air. The foregoing relation may be applied to gases with inert content of 10 percent or less without introducing an absolute error of more than 1 or 2 percent in the calculated limits.

The **rate of flame propagation** or **burning velocity** in gas-air mixtures is of importance in utilization problems, including those dealing with burner design and rate of energy release. There are several methods that have been used for measuring such burning velocities, in both laminar and turbulent flames. Results by the various methods do not agree, but

Table 7.1.21 Flammability Limits of Gases in Air

Gas	Flammable limits in air, vol %	
	Lower	Upper
Methane	5.0	15.0
Ethane	3.0	12.4
Propane	2.1	9.5
Butane	1.8	8.4
Isobutane	1.8	8.4
Pentane	1.4	7.8
Isopentane	1.4	7.6
Hexane	1.2	7.4
Ethylene	2.7	36.0
Propylene	2.4	11.0
Butylene	1.7	9.7
Acetylene	2.5	100.0
Hydrogen	4.0	75.0
Carbon monoxide	12.5	74.2
Ammonia	15.0	28.0
Hydrogen sulfide	4.0	44.0
Natural	4.8	13.5
Producer	20.2	71.8
Blast-furnace	35.0	73.5
Water	6.9	70.5
Carbureted-water	5.3	40.7
Coal	4.8	33.5
Coke-oven	4.4	34.0
High-Btu oil	3.9	20.1

any one method does give relative values of utility. Maximum burning velocities for turbulent flames are greater than those for laminar flames. The bunsen flame method gives results that have significance in gas utilization problems. In this method, the burning velocity is determined by dividing the volume rate of gas flow from the bunsen burner by the area of the inner cone of the flame.

The use of other fuels and equipment to supplement the regular supply of gas during periods of peak demand or in emergencies is known as **peak shaving**. Most gas utilities, particularly natural-gas utilities at the end of long-distance transmission lines, maintain peak-shaving or standby equipment. Also, gas utilities in many cases have established natural-gas storage facilities close to their distribution systems. This allows gas to be stored underground near the point of consumption during periods of low demand, as in summer, and then withdrawn to meet peak or emergency demands, as may occur in winter. Propane-air mixtures are the major supplements to natural gas for peak shaving use. Gas manufactured by cracking various petroleum distillates supplies most of the remaining peak requirements.

SYNTHETIC FUELS

by Martin D. Schlesinger

Wallington Group Ltd.

REFERENCES: U.S. Department of Energy, Fossil Energy Reports. Whitehurst et al., "Coal Liquefaction," Academic. Speight, "The Chemistry and Technology of Coal," Marcel Dekker. Preprints, Division of Fuel Chemistry, American Chemical Society. Annual International Conferences on Coal Gasification, Liquefaction, and Conversion to Electricity, Department of Chemical and Petroleum Engineering, University of Pittsburgh.

Liquid and gaseous fuels in commercial use can be produced from sources other than petroleum and natural gas. Much new technology has been developed during the twentieth century as the threat of petroleum shortages or isolation loomed periodically. The result was the improvement of known processes and the introduction of new concepts.

A generalized flow sheet Fig. 7.1.3, shows the routes that can be followed from coal to finished products. Liquid and gaseous fuels are formed from coal by increasing its hydrogen to carbon ratio. Primary

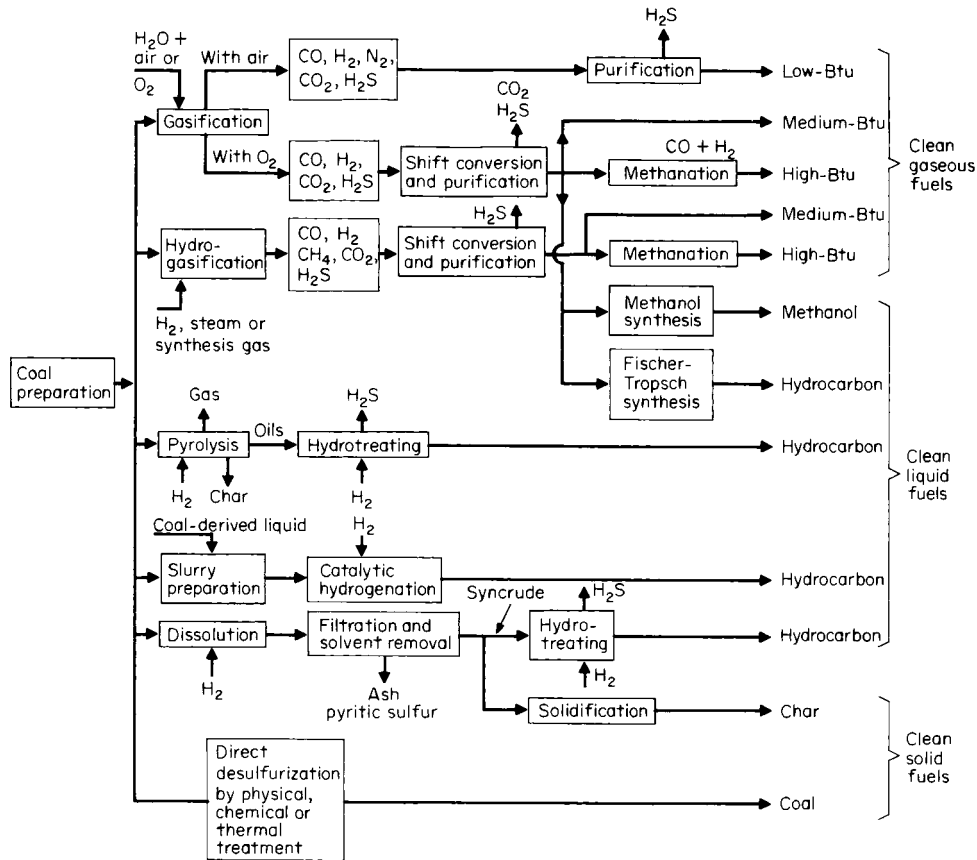

Fig. 7.1.3 Clean fuels from coal.

conversion products are deashed, desulfurized, and further upgraded to a wide range of clean fuels. Gasification can yield clean gases for combustion or synthesis gas with a controlled ratio of hydrogen to carbon monoxide. Catalytic conversion, of synthesis gas to fluids (indirect liquefaction) can be carried out in fixed and fluidized beds and in dilute phase systems. Both gases and liquids are used as the temperature control medium for the exothermic reactions.

Direct liquefaction is accomplished by pyrolysis or hydrogenation and several processes are available for each approach for adding hydrogen to the coal and removing undesirable constituents. The amount of hydrogen consumed is determined by the properties desired in the final product, whether it be a heavy fuel oil, diesel oil, jet fuel, gasoline, or gases. Clean solid fuels, i.e. with low ash and low sulfur contents, can be produced as a product of pyrolysis, from liquefaction residues, or by chemical treatment of the coal.

What must be done with some naturally occurring sources of fuels is exemplified in Fig. 7.1.4. Upgrading involves the addition of hydrogen and more hydrogen is required to upgrade coal than to process petroleum into finished products. The ranges are generalized to indicate the relative need for processing and the range of product distributions. Coal contains very little hydrogen, averaging 0.8 H:C atomic ratio and petroleum has about twice the relative amounts. Premium fuels are in the kerosene/gasoline range, which includes diesel and jet fuels. Commercial transportation fuels contain 15 to 18 wt % hydrogen. At the upper end of the scale is methane with an H:C ratio of 4:1. Not considered in the above is the elimination of mineral matter and constituents such as oxygen, sulfur, and nitrogen, where hydrogen is consumed to form water, hydrogen sulfide, and ammonia. Some oxygen is removed as carbon dioxide.

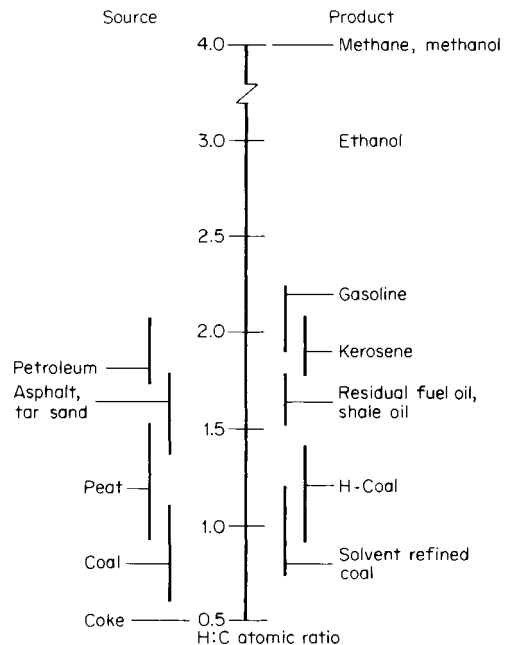

Fig. 7.1.4 Upgrading of carbonaceous sources.

Coal liquefaction is accomplished by four principal methods: (1) direct catalytic hydrogenation, (2) solvent extraction, (3) indirect catalytic by hydrogenation (of carbon monoxide), and (4) pyrolysis. In one approach to direct hydrogenation, coal and the catalyst are mixed with a coal-derived recycle oil and the slurry is pumped into a high-pressure system where hydrogen is present. Operating conditions are generally 400 to 480°C and 1,500 to 5,000 lb/in² (10×10^6 to 35×10^6 N/m²). A heavy syncrude is produced at the milder conditions, and high yields of distillable oils are produced at the more severe conditions. Effective catalysts contain iron, molybdenum, cobalt, nickel, and tungsten. Figure 7.1.5 is a schematic flow sheet of the **H-coal process** that carries out the direct hydrogenation by bringing the coal-oil slurry into contact with an ebullating bed of catalyst. The product is generally aromatic, and the gasoline fraction produced after further hydrogenation has a high octane number. Many chemicals of commercial value are also found in the oil.

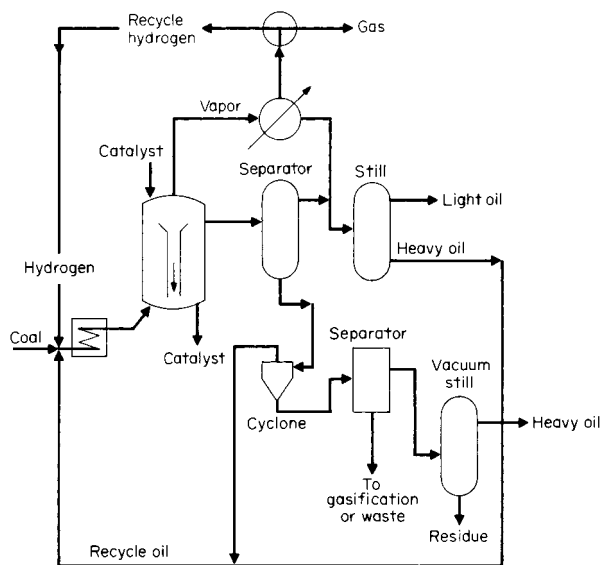

Fig. 7.1.5 H-coal schematic.

Solvent extraction processing solubilizes and disperses coal in a hydroaromatic solvent that transfers some of its hydrogen to the coal. Ash and insoluble coal are separated from the liquid product to recover recycle oil and product oil. The carbonaceous residue is reacted with steam in a gasifier to produce the hydrogen needed. Figure 7.1.6 is a schematic flow sheet of the **solvent-refined coal (SRC I)** process. By recy-

cling some of the mineral matter from the coal as a catalyst and increasing the severity of the operating conditions, a lighter hydrocarbon product is formed. SRC I product is a solid at room temperature. Further improvement can be achieved by hydrogenation of the solvent to control the hydroaromatic content of the recycle stream and to improve the product quality. The **Exxon donor solvent (EDS)** process uses this latter technique, and no catalyst is required in the first contacting vessel.

One version of the solvent extraction system is **two-stage hydrogenolysis**. The integrated sequence starts with pulverized coal in a recycle solvent pumped into a reactor where the slurry is hydrogenated for a short time at 2,400 lb/in² (16.5×10^6 N/m²) and 425 and 450°C. Partially hydrogenated product is vacuum distilled to recover solvent and primary product. Solids are next separated by a critical solvent or an antisolvent process and the ash-free oil is hydrogenated at 2,700 lb/in² and 400°C to produce a final product boiling below 350°C. Some oil is recovered in this below 350°C range, and excess higher-boiling oil is recovered in the vacuum distillation step.

Pyrolysis depends on the controlled application of heat without the addition of hydrogen. Most of the carbon is recovered as solid product; liquids and gases having a hydrogen : carbon ratio higher than the original coal are liberated. The liquid product can be hydrotreated further for sulfur removal and upgrading to specification fuels. By-product gas and char must be utilized in order for the process to be economical. Yields of primary products depend on the coal source, the rate of heating, the ultimate temperature reached, and the atmosphere in which the reaction takes place. Both single and multistage processes were developed but few are used commercially except for the production of metallurgical coke and chars.

Catalytic hydrogenation of carbon monoxide is a flexible method of liquefaction. Catalysts can be prepared from Fe, Ni, Co, Ru, Zn, and Th either alone or promoted on a support. Each catalyst gives a different product distribution that is also a function of the method of preparation and pretreatment. Primary products are normally methane and higher-molecular-weight, straight-chain hydrocarbons, alcohols, and organic acids. Operating conditions for the **Fischer-Tropsch-type synthesis** are usually in the range of 300 to 500 lb/in² (2 to 3.5×10^6 N/m²) and 200 to 400°C. Temperature of the exothermic reaction [-39.4 kcal/(g · mol)] is controlled by carrying out the reaction in fixed beds, fluidized beds, slurry, and dilute phase systems with heat removal. Diesel oil from this type of synthesis has a high cetane number; the paraffin waxes can be of high quality. Generally, the gasoline produced by indirect synthesis has a low octane number because of its aliphatic nature. One method of producing a high-octane gasoline is to make methanol from 2 : 1 H : CO in a first stage and then process the alcohol over a zeolite catalyst. The hydrocarbon product has a narrow boiling range and contains about 30 percent aromatics.

In South Africa there are three commercial coal conversion plants that use the indirect liquefaction method. About 28 million t/yr of coal is gasified under pressure in 97 Lurgi gasifiers; and the synthesis gas, after

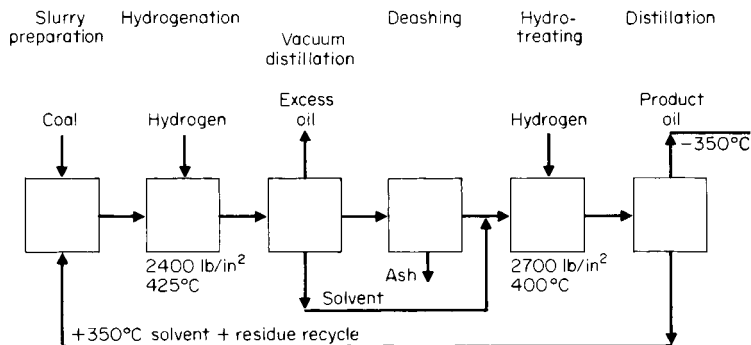

Fig. 7.1.6 Solvent-refined coal.

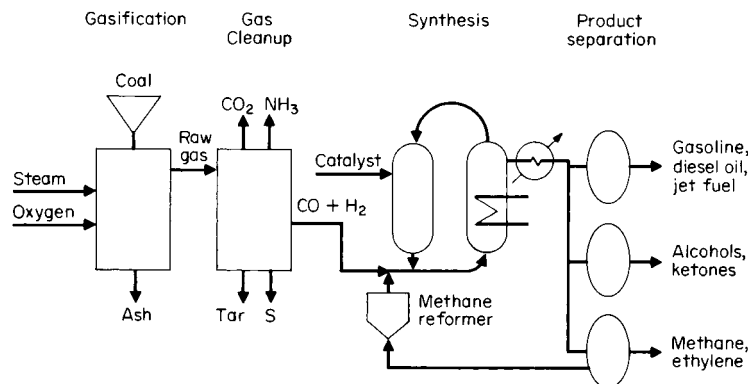

Fig. 7.1.7 Flow sheet of SASOL II and III.

cleaning and adjustment of the hydrogen/carbon monoxide ratio, is passed through catalyst beds. A total output of 150,000 bpd (23,850 m³) of automotive fuel provides about one-half of the nation's needs. There is also produced about 1,600 tpd of chemicals. The simplified flow sheet in Fig. 7.1.7 shows some of the main features of the plants.

SASOL I (SASOL Chemical Industries) uses fixed-bed reactors and dilute phase systems; the fixed bed makes higher-molecular-weight products. **SASOL II and III** (SASOL synthetic fuels) do not produce the fixed-bed heavy hydrocarbons but maximize gasoline and diesel oil formation by hydrotreating and reforming.

Research is reported to be continuing on the application of the slurry process and direct hydrogenation to coal conversion technology.

Shale oil is readily produced by the thermal processing of many shales. The basic technology is available and commercial plants are operated in many parts of the world. The first modern plant in the United States was put on stream in 1983 by the Union Oil Co. in Colorado. About 12,500 tons of raw shale, averaging 35 gal/ton (0.145 m³/1,000 kg), crushed to 5-cm particles, is pushed upward into the retort each day, and at 400 to 500°C crude shale oil is produced from the kerogen in the shale.

The refined product yield was 7,000 bpd (1,115 m³/d) of diesel oil and 3,000 bpd (475 m³/d) of jet fuel. The present low cost of petroleum has not justified the continued development of this and other systems. Estimated reserves are equivalent to about 3 billion barrels of shale oil. Figure 7.1.8 is a generalized flow sheet of the process.

Tar sand is a common term for oil-impregnated sediments that can be found in almost every continent. High-grade tar sands have a porosity of 25 to 35 percent and contain about 18 percent by weight of bitumen. The sand grains are wetted by about 2 percent of water, making them hydrophilic and thus more amenable to hot-water extraction. Solvent extraction, thermal retorting, in situ combustion, and steam injection methods have been tested.

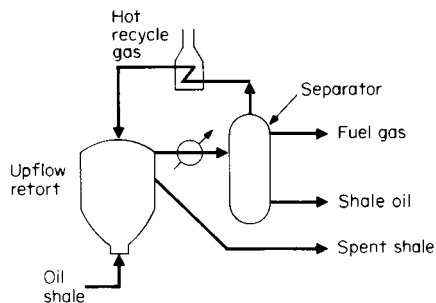

Fig. 7.1.8 Shale oil processing.

Reserves of tar sands in the United States are equivalent to about 30 billion barrels of petroleum. Most of the deposits are too deep for surface mining and require in situ treatment before extraction. Some of the surface deposits are worked to produce asphalt for highway application and other minor uses.

Tar sand is a source of hydrocarbon fuels at Syncrude Canada in Alberta. Two commercial plants with combined capacity of 190,000 bpd of synthetic crude oil operate in this region and use the principle of ore mining, hot-water extraction, coking (delayed and fluid), and distillate hydrogenation. Methods for modification of the bitumen in situ and recovery without mining are also under investigation. Properties of conventional petroleum, tar sand bitumen, and synthetic crude oil from the bitumen are given in Table 7.1.22.

Table 7.1.22 Comparison of Tar Sand Bitumen and Synthetic Crude Oil from the Bitumen with Petroleum

	Petroleum	Tar sand bitumen	Synthetic crude oil
API gravity	25–27°	8°	
Viscosity			
cSt at 100°F	3–7	120,000	6
cSt at 210°F		2,000	
Carbon, wt %	86.0	83.1	86.3
Hydrogen, wt %	13.5	10.6	13.4
Nickel, ppm	2–10	100	0
Sulfur, wt %	1–2	4.8	0.15
Nitrogen	0.2	0.4	0.06
Vanadium, ppm	2–10	250	0
Ash, wt %	0	1.0	0
Carbon residue, wt %	1–5	14.0	0
Pentane insolubles, wt %	<5	17.0	0

EXPLOSIVES

by J. Edmund Hay

U.S. Department of the Interior

REFERENCES: Meyer, "Explosives," Verlag Chemie. Cook, "The Science of High Explosives," Reinhold. Johansson and Persson, "Detonics of High Explosives," Academic. Davis, "The Chemistry of Powder and Explosives," Wiley. "Manual on Rock Blasting," Aktiebolaget Atlas Diesel, Stockholm. Dick, Fletcher, and D'Andrea, Explosives and Blasting Procedures Manual, *BuMines Inf. Circ.* 8925, 1983.

The term *explosives* refers to any substance or article which is able to function by explosion (i.e., the extremely rapid release of gas and heat) by chemical reaction within itself.

Explosive substances are commonly divided into two types: (1) high

or **detonating explosives** are those which normally function by detonation, in which the chemical reaction is propagated by a shock wave that in turn is driven by the energy released; and (2) low or **deflagrating explosives**, normally function by deflagration, in which the chemical reaction is propagated by convective, conductive, and/or radiative heat transfer. High explosives are further divided into two types: primary explosives are those for which detonation is the only mode of reaction, and secondary explosives may either detonate or deflagrate, depending on a variety of conditions. Low explosives are usually pyrotechnics or propellants for guns, rockets, or explosive-actuated devices.

It is important to note the word *normally*. Not only can many high explosives deflagrate rather than detonate under certain conditions, but also some explosives which are normally considered to be "low" explosives can be forced to detonate. Also note that the definition of *explosive* is itself somewhat elastic—the capability to react explosively is strongly dependent on the geometry, density, particle size, confinement, and initiating stimulus, as well as the chemical composition. Historically, immense grief has resulted from ignorance of these facts. In normal use, the term *explosive* refers to those substances or articles which have been classified as explosive by the test procedures recommended by the United Nations (UN) Committee on the Transport of Dangerous Goods.

According to the UN scheme of classification, most high explosives are designated class 1.1 (formerly called *class A*), and most low explosives are designated class 1.3 (formerly called *class B*). Explosive devices of minimal hazard (formerly called *class C*) are designated class 1.4.

However, a very important subclass of secondary high explosives is designated class 1.5 (formerly called *blasting agents* or *nitrocarbonitrates*). The distinction is based primarily on **sensitivity**: In simplified terms, the initiation of detonation of a class 1.5 explosive requires a stronger stimulus than that provided by a detonator with a 0.45-g PETN base charge which exhibits a low tendency to the deflagration-to-detonation transition.

The important physical properties of high explosives include their bulk density, detonation rate, critical and "ideal" diameters (or thickness), "sensitivity," and strength.

The detonation rate is the linear speed at which the detonation propagates through the explosive, and it ranges from about 6,000 ft/s (1.8 km/s) to about 28,000 ft/s (8.4 km/s), depending on the density and other properties of the explosive.

The *critical diameter* (or thickness, in the case of a sheet explosive) is the minimum diameter or thickness at which detonation can propagate through the material. For most class 1.1 explosives, this is between 1 and 30 mm; for class 1.5 explosives, it is usually greater than 50 mm. This value depends to some extent on the confinement provided by the material adjacent to the explosive. For explosives whose diameter (thickness) is only slightly above the critical value, the detonation rate increases with increasing diameter (thickness), finally attaining a value for which no increase in rate is observed for further increases in dimension. The diameter or thickness at which this occurs is called the *ideal diameter* or *thickness*.

Sensitivity and strength are two of the most misunderstood properties of explosives, in that there is a persistent belief that each of these terms refers to a property with a unique value. Each of these properties can be quantitatively determined by a particular test or procedure, but there are far more such procedures than can even be listed in this space, and there are large deviations from correlation between the values determined by these different tests.

Descriptions of some of the more common explosives or types of high explosive are given below.

Ammonium nitrate—fuel oil (ANFO) blasting agents are the most widely used type of explosive product, accounting for about 90 percent of explosives in the United States. They usually contain 5.5 to 6 percent fuel oil, typically no. 2 diesel fuel. If used underground, the oil content must be carefully regulated to minimize the production of toxic fumes. Some ANFO compositions contain aluminum or densifying agents. Premixed ANFO is usually shipped in 50- to 100-lb bags, although bulk

shipment and storage are practiced in certain operations. ANFO has a density of 0.85 to 1.0 g/cm³ and a detonation velocity in the range of 10,000 to 14,000 ft/s (3,000 to 4,300 m/s). ANFO may also incorporate densifying agents and other fuels such as aluminum, and it may be blended with **emulsions** (see below). The density of such compositions may run as high as 1.5 g/cm³, and the detonation rate as high as 16,000 ft/s (4,800 m/s). ANFO and other blasting agents require the use of high-explosive **primers** to initiate detonation. Commonly used primers are cartridges of ordinary dynamite or specially cast charges of ¼ to ¾ lb of military-type explosives such as **composition B** or **pentolite**. The efficiency of ANFO lies in the method of loading, which fills the borehole completely and provides good coupling with the burden.

Water-based compositions fall into two types. **Water gels** are gelled solutions of ammonium nitrate containing other oxidizers, fuels, and sensitizers such as amine nitrates or finely milled aluminum, in solution or suspension. **Emulsions** are emulsions of ammonium nitrate solution with oil, and they may contain additional oxidizers, fuels, and sensitizers. These compositions are classified either as explosives or as blasting agents depending on their sensitivity. Both types contain a thickening agent to prevent segregation of suspended solids. For larger operations, mobile mixing trucks capable of high-speed mixing and loading of the composition directly into the large-diameter vertical boreholes have become popular. Another advantage of this on-site mixing and loading is the ability to change composition and strength between bottom and top loads. The density of the explosive-sensitized composition is usually about 1.4 g/cm³ but may be as high as 1.7 g/cm³ for the aluminum-sensitized type; detonation velocities vary from 10,000 to 17,000 ft/s (3,000 to 5,200 m/s).

Dynamite is a generic term covering a multitude of nitroglycerine-sensitized mixtures of carbonaceous materials (wood, flour, starch) and oxygen-supplying salts such as ammonium nitrate and sodium nitrate. The nitroglycerin contains ethylene glycol dinitrate or other nitrated compounds to lower its freezing point, and antacids, such as chalk or zinc oxide, are divided into nongelatinous or granular and gelatinous types, the latter containing nitrocellulose. All dynamites are capsensitive.

Straight dynamites are graded by the percentage of explosive oil they contain; this may be as low as 15 percent and as high as 60 percent. A typical percentage formulation for a 40 percent straight dynamite is: nitroglycerin, 40; sodium nitrate, 44; antacid, 2; carbonaceous material, 14. The rate of detonation increases with grade from 9,000 to 19,000 ft/s (2,700 to 5,800 m/s). Straight dynamites now find common use only in ditching where propagation by influence is practiced.

Ammonia dynamites differ from straight dynamites in that some of the sodium nitrate and much of the explosive oil have been replaced by ammonium nitrate. Strength of ammonia dynamites ranges from 15 to 60 percent, each grade having the same weight strength as the corresponding straight dynamite when compared in the ballistic mortar. A typical percentage formula for a 40 percent ammonia dynamite is: explosive oil, 14; ammonium nitrate, 36; sodium nitrate, 33; antacid, 1; carbonaceous material, 16. The rate of detonation, 4,000 to 17,000 ft/s (1,200 to 5,200 m/s), again increases with grade. Low-density, high-weight-strength compositions are popular in many applications, but ANFO has displaced them in numerous operations.

Blasting gelatin is the strongest and highest-velocity explosive used in industrial operations. It consists essentially of explosive oil (nitroglycerin plus ethylene glycol dinitrate) colloidized with about 7 percent nitrocellulose. It is completely water-resistant but has a poor fume rating and consequently finds only limited use.

Gelatin dynamites correspond to straight dynamites except that the explosive oil has been gelatinized by nitrocellulose; this results in a cohesive mixture having improved water resistance. Under confinement, the gelatins develop high velocity, ranging from 8,500 to 22,000 ft/s (2,600 to 6,700 m/s) and increasing between the grades of 20 and 90 percent. An approximate percentage composition for a 40 percent grade is: explosive oil, 32; nitrocellulose, 0.7; sulfur, 2; sodium nitrate, 52; antacid, 1.5; and carbonaceous material, 11. In the common grades of 40 and 60 percent, fume characteristics are good, making these types useful for underground hard-rock blasting.

Ammonia gelatin dynamites are similar to the ammonia dynamites except for their nitrocellulose content. These used to be popular in quarrying and hard-rock mining. Their excellent fume characteristics make them suitable for use underground, but again ANFO is widely used. The rates of detonation of 7,000 to 20,000 ft/s (2,000 to 6,000 m/s) are somewhat less than the straight gelatins. A typical percentage composition for the 40 percent grade is: gelatinized explosive oil, 21; ammonium nitrate, 14; sodium nitrate, 49; with antacid and combustible making up the remainder.

The **semigels** are important variants of the ammonia gels; these contain less explosive oil, sodium nitrate, and nitrocellulose and more ammonium nitrate than the corresponding grade of ammonia gel. Rates of detonation fall in the limited range of 10,000 to 13,000 ft/s (3,000 to 4,000 m/s). These powders are cohesive and have good water resistance and good fume characteristics.

Permissible explosives are powders especially designed for use in underground coal mines, which have passed a series of tests established by the Bureau of Mines. The most important of these tests concern incendiarity of the explosives—their tendency to ignite methane-air or methane-coal dust-air mixtures. Permissible explosives are either granular or gelatinous; the granular type makes up the bulk of the powders used

today. Typically, a granular permissible contains the following, in percent: explosive oil, 9; ammonium nitrate, 65; sodium nitrate, 5; sodium chloride, 10; carbonaceous material, 10; and antacid, 1. Gels contain nitrocellulose for improved water resistance and more explosive oil. Detonation velocities for the granular grades vary from 4,500 to 11,000 ft/s (1,400 to 3,400 m/s), and for the gels from 10,500 to 18,500 ft/s (3,200 to 5,600 m/s). Many water-based permissible formulations with comparable physical and safety properties are now marketed as well.

Liquid oxygen explosives (LOX) once saw considerable use in coal strip mines but have been completely displaced by ANFO or water-based compositions. LOX consisted of bags of pressed carbon black or specially processed char that were saturated with liquid oxygen just before loading into the borehole. The rate of detonation ranged from 12,000 to 18,000 ft/s (3,700 to 5,500 m/s).

Military explosives, originally developed for such uses as bomb, shell, and mine loads and demolition work, have been adapted to many industrial explosive applications. The more common military explosives are listed in Table 7.1.23, with their compositions, ballistic mortar strengths, and detonation velocities.

Amatol was used early in World War II, largely because of the short supply of TNT. Modifications of amatol have been used as industrial

Table 7.1.23 Physical Characteristics of Military Explosives

Explosive	Composition, %	Ballistic mortar strength (TNT = 100)	Density, g/cm ³	Rate of detonation, m/s
80/20 amatol	Ammonium nitrate, 80; TNT, 20	117	Cast	4,500
50/50 amatol	Ammonium nitrate, 50; TNT, 50	122	Cast	5,600
Composition A (pressed)	RDX, 91; wax, 9	134	0.80 1.20 1.50 1.60	4,560 6,340 7,680 8,130
Composition B (cast)	RDX, 59.5; TNT, 39.5; wax, 1	130	1.65	7,660
Composition C-3 (plastic)	RDX, 77; tetryl, 3; mononitrotoluene, 5; dinitrotoluene, 10; TNT, 4; nitrocellulose, 1	145	1.55	8,460
Composition C-4 (plastic)	RDX, 91; dioctyl sebacate, 5.3; polyisobutylene, 2.1; oil, 1.6	—	1.59	8,000
Explosive D	Ammonium picrate	97	0.80 1.20 1.50 1.60	4,000 5,520 6,660 7,040
HBX-1	RDX, 40; TNT, 38; aluminum, 17; desensitizer, 5	130	1.70	7,310
Lead azide*	Lead azide	—	2.0 3.0 4.0	4,070 4,630 5,180
PETN	Pentaerythritol tetranitrate	145	0.80 1.20 1.50 1.60	4,760 6,340 7,520 7,920
50/50 Pentolite	PETN, 50; TNT, 50	120	1.20 1.50 1.60	5,410 7,020 7,360
Pieric acid	Trinitrophenol	108	Cast 1.20 1.50	7,510 5,840 6,800
RDX (cyclonite)	Cyclotrimethylene trinitramine	150	Cast 0.80 1.20 1.50 1.60 1.65	7,350 5,110 6,550 7,650 8,000 8,180
Tetryl	Trinitrophenylmethylnitramine	121	0.80 1.20 1.50 1.60	4,730 6,110 7,160 7,510
75/25 Tetrytol	Tetryl, 75; TNT, 25	113	1.60	7,400
TNT	Trinitrotoluene	100	0.80 1.20 1.50 1.60 Cast	4,170 5,560 6,620 6,970 6,790

* Primary compound for blasting caps.

blasting agents. **Explosive D**, or ammonium picrate, by virtue of its extreme insensitivity, was used in explosive-filled armor-piercing shells and bombs.

RDX, a very powerful explosive compound, was widely used during World War II in many compositions, of which Compositions A, B, and C were typical. **Composition A** was used as a shell loading; **B** was used as a bomb and shaped charge filling; **C**, being plastic enough to allow molding to desired shapes, was developed for demolition work. Compositions that also contained aluminum powder were developed for improved underwater performance (**Torpex**, **HBX**). RDX has found limited commercial application as the base charge in some detonators, the filling for special-purpose detonating fuses or cordeau detonants, and the explosive in small shaped charges used as oil well perforators and tappers for openhearth steel furnaces.

PETN has never found wide military application because of its sensitivity and relative instability. It is used extensively, however, as the core of detonating fuses and in caps and, mixed with **TNT**, in boosters.

Tetryl, once widely used by the military as a booster loading and commercially as a base charge in detonators, has been displaced by other compositions. **Tetrytol** found limited application as a demolition charge.

TNT is a very widely used military explosive. Its stability, insensitivity, convenient melting point (81°C), and relatively low cost have made it the explosive of choice either alone or in admixture with other materials for loadings which are to be cast. A free-flowing pelletized form has found application in certain types of blasting requiring high loading density, where it is used to fill the cavity formed in sprung holes or the free space around the column of other explosives in the borehole.

DUST EXPLOSIONS

by Harry C. Verakis and John Nagy (Retired)

Mine Safety and Health Administration

REFERENCES: Nagy and Verakis, "Development and Control of Dust Explosions," Dekker. "Classification of Dusts Relative to Electrical Equipment in Class II Hazardous Locations," NMAB 353-4, National Academy of Sciences, Washington. "Fire Protection Handbook," 17th ed., National Fire Protection Assoc. *BuMines Rept. Inv.* 4725, 5624, 5753, 5971, 7132, 7208, 7279, 7507. Eckhoff, "Dust Explosions in the Process Industries," Butterworth-Heinemann.

A dust explosion hazard exists where combustible dusts accumulate or are processed, handled, or stored. The possibility of a dust explosion may often be unrecognized because the material in bulk form presents little or no explosion hazard. However, if the material is dispersed in the atmosphere, the potential for a dust explosion is increased significantly. The first well-recorded dust explosion occurred in a flour mill in Italy in 1785. Dust explosions continue to plague industry and cause serious disasters with loss of life, injuries, and property damage. For example, there were about 100 reportable dust explosions (excluding grain dust) from 1970 to 1980 which caused about 25 deaths and a yearly property loss averaging about \$20 million. A complete and accurate record of the number of dust explosions, deaths, injuries, and property damage is unavailable because reporting of each incident is not required unless a fatality occurs or more than five persons are seriously injured. In recent years, most dust explosions have involved wood, grain, resins and plastics, starch, and aluminum. Most of the incidents occurred during crushing or pulverizing, buffing or grinding, conveying, and at dust collectors.

Despite the well-recognized hazards inherent with explosive dusts, the vast amount of technical data accumulated and published, and standards for prevention of and protection from dust explosions, severe property damage and loss of life occur every year. As an example of the severity of dust explosions, there was a series of explosions in four grain elevators during December 1977, which caused 59 deaths, 47 injuries, and nearly \$60 million in property damage.

A **dust explosion** is the rapid combustion of a cloud of particulate matter in a confined or partially confined space in which heat is gener-

ated at a higher rate than it is dissipated. In a confined space, the explosion is characterized by relatively rapid development of pressure with the evolution of large quantities of heat and reaction products. The condition necessary for a dust explosion to occur is the simultaneous presence of a dust cloud of proper concentration in air or gas that will support combustion and an ignition source.

Dust means particles of materials smaller than 0.016 in in diameter, or those particles passing a no. 40 U.S. standard sieve, 425 μm (this definition relates to the limiting size, not to the average particle size of the material); and **explosible** dust means a dust which, when dispersed, is ignited by spark, flame, heated coil, or in the Godbert-Greenwald furnace at or below 730°C, when tested in accordance with the equipment and procedures described in *BuMines Rept. Inv.* 5624.

Explosibility Factors

Empirical methods and experimental data are the chief guides in evaluating relative dust explosion hazards. A mathematical model correlating some of the numerous interrelated factors affecting dust explosion development in closed vessels has been developed. Details of the model are presented in Nagy and Verakis, "Development and Control of Dust Explosions."

Dust Composition Many industrial dusts are not pure compounds. The severity of a dust explosion varies with the chemical constitution and certain physical properties of the dust. High percentages of non-combustible material, such as mineral matter or moisture, reduce the ease of oxidation, and oxygen requirements influence the explosibility of dusts. Volatile, combustible components in such materials as coals, asphalts, and pitches increase explosibility.

Dust composition also affects the amount and type of products produced in an explosion. Organic materials evolve new gaseous products, whereas most metals form solid oxides during combustion in an air atmosphere.

Particle Size and Surface Area Explosibility of dusts increases with a decrease in particle size. Fine dust particles have greater surface area, more readily disperse into a cloud, mix better with air, remain longer in suspension, and oxidize more rapidly and completely than coarse particles. Decrease of particle size generally results in lower ignition temperature, lower igniting energy, lower minimum explosive concentration, and higher pressure and rates of pressure rise. Some metals, such as chromium, become explosive only at very fine particle sizes (average particle diameter of 3 μm), and almost all metals become pyrophoric if reduced to very fine powder.

Range of Explosibility Most combustible dusts have a well-defined lower limit, but the upper limit is usually indefinite. The upper limit has been determined for only a few dusts, but these data have only limited importance in practice. The range of dust explosibility is normally 0.015 to greater than 10 oz/ft³ (10 kg/m³). The optimum concentration producing the strongest dust explosions is about 0.5 to 1.0 oz/ft³. Table 7.1.24 gives explosion characteristics for a number of dusts at a concentration of 0.5 oz/ft³. A typical example of the effect of dust concentration on maximum pressure and maximum rate of pressure rise from explosions in closed vessels of various size and shape is shown in Figs. 7.1.9 and 7.1.10.

Ignition Source Ignition sources known to have initiated dust explosions in industry include electric sparks and arcs in fuses, faulty wiring, motors and other appliances, static electrical fuses, faulty wiring, motors and other appliances, static electrical discharges, open flames, frictional, or metallic sparks, glowing particles, overheated bearings and other machine parts; hot electric bulbs, overheated driers, and other hot surfaces; dust layers may also ignite by these sources as well as by spontaneous ignition. Ignition temperatures of many dust clouds are given in Table 7.1.24. Normally the ignition temperature of a dust layer is considerably less than for a dust cloud. The position and intensity of the ignition source affect dust-explosion development; detailed information on these factors is presented in *BuMines Rept. Inv.* 7507.

Turbulence Turbulence has a slight effect on maximum pressure, but a marked effect on the rates of pressure rise for dust explosions.

Table 7.1.24 Explosive Characteristics of Various Dusts*

Type of dust	Ignition temperature of dust cloud, °C	Minimum igniting energy, J	Minimum explosive concentration, oz/ft ³	Maximum explosion pressure, lb/in ² gage	Maximum rate of pressure rise, lb/(m ²)(s)	Terminal oxygen concentration, %†
Agricultural:						
Alfalfa	530	0.320	0.105	92	2,200	
Cereal grass	550	0.800	0.250	52	500	
Cinnamon	440	0.030	0.060	114	3,900	
Citrus peel	730	0.045	0.065	71	2,000	
Cocoa	500	0.120	0.065	55	900	
Coffee	720	0.160	0.085	53	300	
Corn	400	0.040	0.055	95	6,000	
Corncob	480	0.080	0.040	110	3,100	
Corn dextrine	410	0.040	0.040	105	7,000	
Cornstarch	390	0.030	0.040	115	9,000	
Cotton linters	520	1.920	0.500	48	150	
Cottonseed	530	0.120	0.055	96	3,000	
Egg white	610	0.640	0.140	58	500	
Flax shive	430	0.080	0.080	81	800	
Garlic	360	0.240	0.100	80	2,600	
Grain, mixed	430	0.030	0.055	115	5,500	
Grass seed	490	0.260	0.290	34	400	
Guar seed	500	0.060	0.040	98	2,400	
Gum, Manila (copal)	360	0.030	0.030	88	5,600	
Hemp hurd	440	0.035	0.040	103	10,000	
Malt, brewers	400	0.035	0.055	92	4,400	
Milk, skim	490	0.050	0.050	83	2,100	
Pea flour	560	0.040	0.050	95	3,800	
Peanut hull	460	0.050	0.045	82	4,700	
Peat, sphagnum	460	0.050	0.045	84	2,200	
Pecan nutshell	440	0.050	0.030	106	4,400	
Pectin	410	0.035	0.075	112	8,000	
Potato starch	440	0.025	0.045	97	8,000	
Pyrethrum	460	0.080	0.100	82	1,500	
Rauwolfia vomitoria root	420	0.045	0.055	106	7,500	
Rice	440	0.050	0.050	93	2,600	
Safflower	460	0.025	0.055	84	2,900	
Soy flour	550	0.100	0.060	111	1,600	15
Sugar, powdered	370	0.030	0.045	91	1,700	
Walnut shell, black	450	0.050	0.030	97	3,300	
Wheat flour	440	0.060	0.050	104	4,400	
Wheat, untreated	500	0.060	0.065	98	4,400	
Wheat starch	430	0.025	0.045	100	6,500	
Wheat straw	470	0.050	0.055	99	6,000	
Yeast, torula	520	0.050	0.050	105	2,500	
Carbonaceous:						
Asphalt, resin, volatile content 57.5%	510	0.025	0.025	94	4,600	
Charcoal, hardwood mix, volatile content 27.1%	530	0.020	0.140	100	1,800	18
Coal, Colo., Brookside, volatile content, 38.7%	530	0.060	0.045	88	3,200	
Coal, Ill., no. 7, volatile content 48.6%	600	0.050	0.040	84	1,800	15
Coal, Ky., Breek, volatile content 40.6%	610	0.030	0.050	88	4,000	
Coal, Pa., Pittsburgh, volatile content 37.0%	610	0.060	0.055	83	2,300	17
Coal, Pa., Thick Freeport, volatile content, 35.6%	595	0.060	0.060	77	2,200	
Coal, W. Va., no. 2 Gas, volatile content 37.1%	600	0.060	0.060	82	1,600	
Coal, Wyo., Laramie no. 3, volatile content 43.3%	575	0.050	0.050	92	2,000	
Gilsonite, Utah, volatile content 86.5%	580	0.025	0.020	78	3,700	
Lignite, Calif., volatile content 60.4%	450	0.030	0.030	90	8,000	
Pitch, coal tar, volatile content 58.1%	710	0.020	0.035	88	6,000	
Chemical compounds:						
Benzoic acid, C ₆ H ₅ COOH	620	0.020	0.030	74	5,500	
Phosphorus pentasulfide, P ₂ S ₅ , slowly cooled to give single crystals	280	0.015	0.050	54	10,000+	
Phosphorus pentasulfide, P ₂ S ₅ , cooled quickly	290	0.015	0.050	58	7,500	13

Table 7.1.24 Explosive Characteristics of Various Dusts* (Continued)

Type of dust	Ignition temperature of dust cloud, °C	Minimum igniting energy, J	Minimum explosive concentration, oz/ft ³	Maximum explosion pressure, lb/in ² gage	Maximum rate of pressure rise, lb/(m ²)(s)	Terminal oxygen concentration, %†
Chemical compounds (Continued):						
Phthalimide, C ₈ H ₄ (CO) ₂ NH	630	0.050	0.030	79	4,500	
Potassium bitartrate, KHC ₄ H ₄ O ₆	520					
Salicylanilide, <i>o</i> -HOC ₆ H ₄ CONHC ₆ H ₅	610	0.020	0.040	61	4,400	
Sodium thiosulfate, anhydrous, Na ₂ S ₂ O ₃	510					
Sorbic acid, CH ₃ (CH:CH) ₂ COOH	470	0.015	0.020	88	10,000+	
Sucrose, C ₁₂ H ₂₂ O ₁₁	420	0.040	0.045	82	4,200	14
Sulfur, S ₈ 100% finer than 44 μm	210	0.020	0.045	56	3,100	
Sulfur, S ₈ , avg particle size 4 μm	190	0.015	0.035	78	4,700	12
Drugs:						
Aspirin (acetylsalicylic acid), <i>o</i> -CH ₃ COOC ₆ H ₄ COOH, fine	660	0.025	0.050	83	10,000+	
Mannitol (hexahydric alcohol), CH ₂ OH(CHOH) ₄ CH ₂ OH	460	0.040	0.065	82	2,800	
Secobarbital sodium, C ₁₂ H ₁₇ N ₂ O ₃ Na	520	0.960	0.100	54	500	
Vitamin C, ascorbic acid, C ₆ H ₈ O ₆	460	0.060	0.070	88	4,800	15
Explosives and related compounds:						
Dinitrobenzamide	500	0.045	0.040	94	6,500	
Dinitrobenzoic acid	460	0.045	0.040	92	4,300	
Dinitro-sym-diphenyl-urea (dinitrocarbanilide)	550	0.060	0.095	87	2,500	
Dinitrotoluamide (3,5-dinitro-ortho-toluamide)	500	0.015	0.050	106	10,000-	13
Metals:						
Aluminum	650	0.015	0.045	100	10,000+	2
Antimony	420	1.920	0.420	8	100	16
Boron	470	0.060	0.100	90	2,400	
Cadmium	570	4.000				
Chromium	580	0.140	0.230	56	5,000	14
Cobalt	760					
Copper	900					
Iron	420	0.020	0.100	46	6,000	10
Lead	710					
Magnesium	520	0.020	0.020	94	10,000+	0
Molybdenum	720					
Nickel	950+					
Selenium	950+					
Silicon	780	0.080	0.100	106	10,000+	12
Tantalum	630	0.120	0.200	51	3,700	
Tellurium	550					
Thorium	270	0.005	0.075	48	3,300	0
Tin	630	0.080	0.190	37	1,300	15
Titanium	460	0.010	0.045	80	10,000+	0
Tungsten	950+					
Uranium	20	0.045	0.060	53	3,400	0
Vanadium, 86%	500	0.060	0.220	48	600	13
Zinc	600	0.640	0.480	48	1,800	9
Zirconium	20	0.005	0.045	65	9,000	0
Alloys and compounds:						
Aluminum-cobalt	950	0.100	0.180	78	8,500	
Aluminum-copper	930	1.920	0.280	27	500	
Aluminum-iron	550	0.720	0.500	21	100	
Aluminum-magnesium	430	0.020	0.020	90	10,000	0
Aluminum-nickel	940	0.080	0.190	79	10,000	14
Aluminum-silicon, 12% Si	670	0.060	0.040	74	7,500	
Calcium silicide	540	0.130	0.060	73	10,000+	8
Ferchromium, high-carbon	790		2.000			19
Ferromanganese, medium-carbon	450	0.080	0.130	47	4,200	
Ferrosilicon, 75% Si	860	0.400	0.420	87	3,600	16
Ferrotitanium, low-carbon	370	0.080	0.140	53	9,500	13

Table 7.1.24 Explosive Characteristics of Various Dusts* (Continued)

Type of dust	Ignition temperature of dust cloud, °C	Minimum igniting energy, J	Minimum explosive concentration, oz/ft ³	Maximum explosion pressure, lb/in ² gage	Maximum rate of pressure rise, lb/(m ²)(s)	Terminal oxygen concentration, %†
Alloys and compounds (Continued):						
Ferrovandium	440	0.400	1.300			17
Thorium hydride	260	0.003	0.080	60	6,500	6
Titanium hydride	440	0.060	0.070	96	10,000+	13
Uranium hydride	20	0.005	0.060	43	6,500	0
Zirconium hydride	350	0.060	0.085	69	9,000	8
Plastics:						
Acetal resin (polyformaldehyde)	440	0.020	0.035	89	4,100	11
Acrylic polymer resin	480	0.010	0.030	85	6,000	11
Methyl methacrylate-ethyl acrylate						
Alkyd resin	500	0.120	0.155	15	150	15
Alkyd molding compound						
Allyl resin, allyl alcohol derivative, CR-39	500	0.020	0.035	106	10,000+	13
Amino resin, urea-formaldehyde molding compound	450	0.080	0.075	89	3,600	17
Cellulosic fillers, wood flour	430	0.020	0.035	110	5,500	17
Cellulosic resin, ethyl cellulose molding compound	320	0.010	0.025	102	6,000	11
Chlorinated polyether resin, chlorinated polyether alcohol	460	0.160	0.045	66	1,000	
Cold-molded resin, petroleum resin	510	0.030	0.025	94	4,600	
Coumarone-indene resin	520	0.010	0.015	93	10,000+	14
Epoxy resin	530	0.020	0.020	86	6,000	12
Fluorocarbon resin, fluorethylene polymer	600					
Furane resin, phenol furfural	520	0.010	0.025	90	8,500	14
Ingredients, hexamethylenetetramine	410	0.010	0.015	98	10,000+	14
Miscellaneous resins, petrin acrylate monomer	220	0.020	0.045	104	10,000+	
Natural resin, rosin, DK	390	0.010	0.015	87	10,000+	14
Nylon polymer resin	500	0.020	0.030	89	7,000	13
Phenolic resin, phenol-formaldehyde molding compound	500	0.020	0.030	92	10,000+	14
Polycarbonate resin	710	0.020	0.025	78	4,700	15
Polyester resin, polyethylene terephthalate	500	0.040	0.040	91	5,500	13
Polyethylene resin	410	0.010	0.020	83	5,000	12
Polymethylene resin, carboxypolymethylene	520	0.640	0.115	70	5,500	
Polypropylene resin	420	0.030	0.020	76	5,000	
Polyurethane resin, polyurethane foam	510	0.020	0.025	88	3,700	
Rayon (viscose) flock	520	0.240	0.055	88	1,700	
Rubber, synthetic	320	0.030	0.030	93	3,100	15
Styrene polymer resin, polystyrene latex	500	0.020	0.020	91	7,000	13
Vinyl polymer resin, polyvinyl butyral	390	0.010	0.020	84	2,000	14

* Data taken from the following *Bureau of Mines Reports of Investigations*: RI 5753, "Explosibility of Agricultural Dusts"; RI 5971, "Explosibility of Dusts Used in the Plastics Industry"; RI 6516, "Explosibility of Metal Powders"; RI 7132, "Dust Explosibility of Chemicals, Drugs, Dyes and Pesticides"; RI 7208, "Explosibility of Miscellaneous Dusts." The data were obtained using the equipment described in RI 5624, "Laboratory Equipment and Test Procedures for Evaluating Explosibility of Dusts."

† The terminal oxygen concentration is the limiting oxygen concentration in air-CO₂ atmosphere required to prevent ignition of dust clouds by electric spark.

Experiments show the maximum rate of pressure rise in a highly turbulent dust-air mixture can be as much as 8 times higher than in a nonturbulent mixture (*BuMines Repts. Inv.* 5815 and 7507 and Nagy and Verakis).

Moisture and Other Inerts Moisture in a dust absorbs heat and tends to reduce the explosibility of a dust. A high concentration of moisture in the dust also tends to reduce the dispersibility of a dust. An increase in moisture content causes an increase in ignition temperature and a reduction in maximum pressure and rates of pressure rise. However, the amount of moisture required to produce a marked lowering of the explosibility parameters is higher than can ordinarily be tolerated in industrial processes. Most mineral inert dusts admixed with a combustible absorb heat during the combustion reaction and reduce explosibility similar to the action of water. Some chemical compounds, such as sodium and potassium carbonates, act as inhibitors and are more effective than mineral inerts; the limiting inert dust concentration required to prevent ignition and explosion depends on the strength of the igniting source.

Atmospheric Oxygen Concentration The pressure and rate of pressure development decrease as the oxygen concentration in the atmosphere decreases. The ignition sensitivity of dusts decreases with decrease in oxygen concentration and for most dusts, ignition and explosion can be prevented by reducing the oxygen concentration to a safe value. Carbon dioxide, nitrogen, argon, helium, and water vapor are effective diluents. For highly reactive metal powders, only argon and helium are chemically inert. Limiting oxygen concentrations using carbon dioxide as a diluent are given in Table 7.1.24 for many dusts. With carbon dioxide as a diluent, a reduction of oxygen in the atmosphere to 11 percent is sufficient to prevent ignition by sparks for all dusts tested except the metallic powders. With nitrogen as the diluent, ignition of nonmetallic dusts is prevented by diluting the atmosphere to 8 percent oxygen. Some metal dusts, such as magnesium, titanium, and zirconium, ignite by spark in a pure carbon dioxide atmosphere. Freon and halons are sometimes used as diluent gases, but if metal dusts are involved, they can intensify rather than suppress ignition. The limiting oxygen concentration decreases as the dust becomes finer in particle

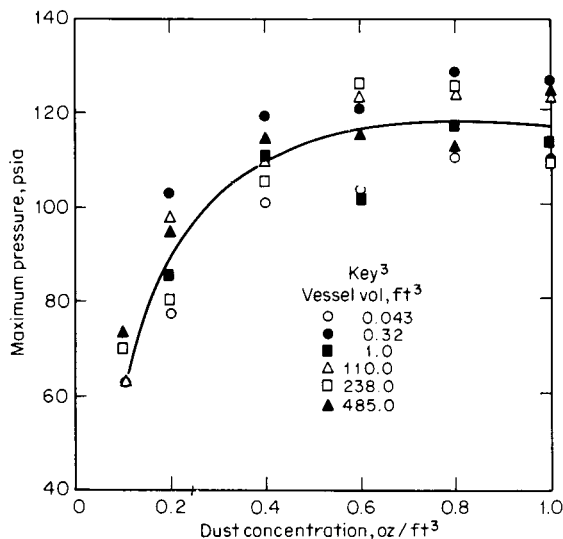

Fig. 7.1.9 Effect of dust concentration on maximum pressure produced by explosions of cellulose acetate dust in closed vessels.

size; limiting oxygen concentration varies slightly with dust concentration and is lowest at concentrations two to five times the stoichiometric mixture.

Relative Dust Explosion Hazards

Table 7.1.24 gives test results of selected dusts whose explosive characteristics have been evaluated in the laboratory by the Bureau of Mines. The data were obtained for dusts passing a no. 200 sieve and represent the most hazardous of the specific materials tested. The values are relative rather than absolute since the test apparatus and experimental procedures affect the results to some degree. The samples were dried before testing only if the moisture content exceeded 5 percent. Detailed description of the equipment and procedures for the small-scale testing are given in *BuMines Rept. Inv. 5624*.

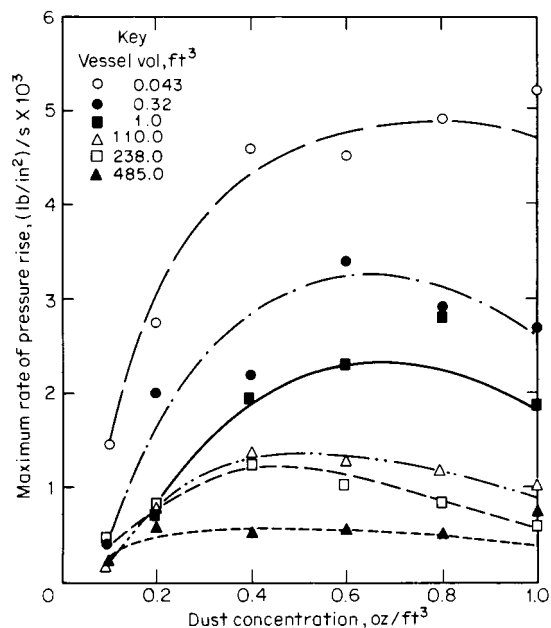

Fig. 7.1.10 Effect of dust concentration on maximum rate of pressure rise by

Ignition Temperature The ignition temperature of a dust cloud was determined by dispersing dust through a heated cylindrical furnace. The ignition temperature is the minimum furnace temperature at which flame appears at the bottom of the furnace in one or more trials in a group of four.

Minimum Energy The minimum electrical spark energy required to ignite a dust cloud was determined by dispersing the dust in a vertically mounted, 2¾-in-diameter, 12-in-long tube. The dust is dispersed by an air blast and then a condenser of known capacitance and voltage is discharged through a spark gap located within the dust dispersion. The top of the tube is enclosed with a paper diaphragm. The minimum energy for ignition of the dust cloud is the least amount of energy required to produce flame propagation 4 in or longer in the tube.

Minimum Concentration The minimum explosive concentration or the lower explosive limit of a dust cloud was determined in a vertically mounted, 2¾-in diameter, 12-in-long tube using a continuous spark-igniting source. A known weight of dust was dispersed within the tube by an air blast. The lowest weight of dust at which sufficient pressure develops to burst a paper diaphragm enclosing the tube or which causes flame to fill the tube is used to calculate the minimum explosive concentration; this calculation is made utilizing the tube volume.

Maximum Pressure and Rates of Pressure Rise The maximum pressure and rates of pressure rise developed by a dust explosion were determined by dispersing dust in a closed steel tube. A continuous spark is used for ignition. A transcribed pressure-time record is obtained during the test. The maximum rate is the steepest slope of the pressure-time curve. Normally, explosion tests are made at dust concentrations of 0.10 to 2.0 oz/ft³. Maximum pressure is primarily dependent on dust composition and independent of vessel size and shape. The maximum rate of pressure rise increases as vessel size decreases.

Explosibility Index The overall explosion hazard of a dust is related to the ignition sensitivity and to explosion severity and is characterized by empirical indexes. The ignition sensitivity of a dust cloud depends on the ignition temperature, minimum energy, and minimum concentration. The explosion severity of a dust depends on the maximum pressure and maximum rate of pressure rise. The indexes are not derived from theoretical considerations, but provide a numerical rating consistent with research observations and practical experience. Results obtained for a sample dust are compared with values for a standard Pittsburgh-seam coal dust. The indexes are defined as follows:

Ignition sensitivity =

$$\frac{(\text{ign temp} \times \text{min energy} \times \text{min conc}) \text{ Pittsburgh coal dust}}{(\text{ign temp} \times \text{min energy} \times \text{min conc}) \text{ sample dust}}$$

Explosion severity =

$$\frac{(\text{max explosive pressure} \times \text{max rate of pressure rise}) \text{ sample dust}}{(\text{max explosive pressure} \times \text{max rate of pressure rise}) \text{ Pittsburgh coal dust}}$$

Explosibility index = ignition sensitivity \times explosion severity

A dust having ignition and explosion characteristics equivalent to the standard Pittsburgh-seam coal has an explosibility index of unity. The relative hazard of dusts is further classified by the following adjective ratings: fire, weak, moderate, strong, or severe. The notation $\ll 0.1$ designates a combustible dust presenting primarily a fire hazard as ignition of the dust cloud is not obtained by a spark or flame source, but only by an intense, heated surface source. These ratings are correlated with the empirical indexes as follows:

Type of explosion	Ignition sensitivity	Explosion severity	Index of explosibility
Fire	<0.2	<0.5	<0.1
Weak	0.2–1.0	0.50–1.0	<0.1
Moderate	1.0–5.0	1.0–2.0	0.1–1.0
Strong			1.0–10

Prevention of Dust Explosions

(See also Sec. 12.1)

There are codes published by the National Fire Protection Association which contain recommendations for a number of dust-producing industries.

Additional sources of information may be found in the NFPA "Fire Protection Handbook," the Factory Mutual "Handbook of Industrial Loss Prevention," *BuMines Rept. Inv.* 6543, Nagy and Verakis, and Eckhoff.

Safeguards against explosions include, but are not limited to the following:

Good housekeeping: An excellent means to minimize the potential for and extent of an explosion is good housekeeping. Control of dust spillage or leakage and elimination of dust accumulations removes the fuel required for an explosion.

Limited personnel: Wherever a hazardous operation must be performed, the number of persons should be limited to the minimum required for safe operation.

Elimination of Ignition Sources All sources of ignition should be eliminated from equipment containing combustible dust and from adjacent areas. Open flames or lights and smoking should be prohibited. The use of electric or gas cutting and welding equipment for repairs should be avoided unless dust-producing machinery is shut down and all dust has been removed from the machines and from their vicinity. Proper control methods should be instituted for materials susceptible to spontaneous combustion. Additional safety measures to follow are ground and bonding of all equipment to prevent the accumulation of static electrical charges; strict adherence to the National Electric Code when installing electrical equipment and wiring in hazardous locations; use of magnetic separators to prevent entrance of ferrous materials into dust-grinding mills; use of nonferrous blades in fans through which dust passes; and avoidance of spark-producing tools in certain industries and of high-speed shafting and belts. Safeguards against ignition by lightning should also be considered. (See also NFPA no. 77, Static Electricity and NFPA no. 78, Lightning Protection.)

Building and Equipment Construction Buildings should be constructed to minimize the collection of dust on beams, ledges, and other surfaces, particularly overhead. Vacuum cleaning is preferable to other methods for dust removal, but soft push brooms may be used without serious hazard. Buildings, including inside partitions, where combustible dusts are handled or stored should be detached units of incombustible construction. Hazardous units within buildings should be separated by substantial fire walls.

Grinders, conveyors, elevators, collectors, and other equipment which may produce dust clouds should be as dust-tight as possible; they should have the smallest practical interior volume and should be constructed to withstand dust explosion pressures. The degree of turbulence within and around an enclosure should be kept to a minimum to prevent dust from being suspended.

Dust collectors should preferably be located outside of buildings or detached rooms and near the dust source. The choice of a suitable dust collector depends on the particle size, dryness, explosibility, dust concentration, gas velocity and temperature, efficiency and space requirements, and economic considerations. (See also Secs. 9 and 18.)

Inerted Atmosphere Equipment such as grinders, conveyors, pulverizers, mixers, dust collectors, and sacking machines can frequently be protected by using an inerted atmosphere or explosion suppression systems. The inert gas for this purpose may be obtained by dilution of air with flue gases from boilers, internal-combustion engines, or other sources, or by dilution with carbon dioxide, nitrogen, helium from high-pressure cylinders, or gas from inert-gas generators. The amount and rate of application of inert gas required depend upon the permissible oxygen concentration, leakage loss, atmospheric and operating conditions, equipment to be protected, and application method. Addition of inert dusts to the combustible dust may also prevent explosive dust-air mixtures from forming in and around equipment. (See NFPA no. 69, Explosion Prevention Systems.)

nel from dust explosions, dust collectors and other equipment and the rooms in which dust-producing machinery is located should be provided with relief vents. Relief vents properly designed and located will sufficiently relieve explosion pressures in most instances and direct explosion gases away from occupied areas. The vents may be unrestricted or free openings; hinged or pivoted sash that swing outward at a low internal pressure; fixed sash with light wall anchorages; scored glass panes; light wall panels; monitors or skylights; paper, metal foil, or other diaphragms that burst at low pressures; poppet-type vent closures; pullout diaphragms; or other similar arrangements. Vents should be located near potential sources of ignition to keep explosion pressure at a minimum and to prevent a dust explosion from developing into a detonation in long ducts.

Empirical formulas and mathematical methods for calculating the vent area to limit pressure from an explosion have been developed. Unfortunately, because of the many factors involved in determining venting requirements, none of these methods can be considered entirely satisfactory to cover the complete range of situations confronting an equipment or building designer. For example, the maximum pressure that can develop in a vented enclosure during a dust explosion is affected by factors such as the chemical affinity of the combustible material with oxygen, heat of combustion, particle size distribution, degree of turbulence, uniformity of the dust cloud, size and energy of the igniting source, location of the igniting source relative to the vent, area of the vent opening, bursting strength or inertial resistance of the vent closure, initial pressure and initial temperature within an enclosure, and the oxygen concentration of the atmosphere. Because of the complexity of the phenomena during explosion in a vented vessel, information on the required vent area to limit the excess or explosion pressure to be a safe value for a given vessel or structure under specific conditions is still estimated from data obtained by physical tests usually made under severe test conditions. Extremely reactive dusts such as magnesium and aluminum are difficult or nearly impossible to vent successfully if an explosion occurs under optimum conditions. Agricultural dusts, most plastic-type dusts, and other metallic dusts can usually be vented successfully. Materials containing oxygen or a mixture with an oxidant should be subjected to tests before venting is attempted. Information and recommendations on venting are given in NFPA no. 68, "Guide for Venting of Deflagrations" (1994). A mathematical analysis showing the relationship of numerous factors affecting the venting of explosions is presented in "Development and Control of Dust Explosions" (Nagy and Verakis, Dekker).

Information published by others shows that higher values of maximum pressures and rates of pressure rise are normally obtained in vessels larger and differently shaped than the Hartmann apparatus described in *BuMines RI 5624*. Data on maximum pressures and rates obtained from the Hartmann apparatus are shown in Table 7.1.24. A comparison of test data from the Hartmann apparatus and a 1-m³ vessel is shown in "Development and Control of Dust Explosions." NFPA no. 68, "Guide for Venting of Deflagrations" (1994), recommends using the rate of pressure rise data obtained from closed vessels, 1-m³ or larger, in venting calculations.

Combating Dust Fires

The following points should be observed when one is dealing with dust fires, in addition to the usual recommendations for fire prevention and firefighting, including sprinkler protection (see also Secs. 12 and 18).

1. Attention should be directed to the potential hazard of spontaneous heating of dust products, particularly when grinding or pulverizing processes are used.

2. First-aid and firefighting equipment should be installed. Small hoses with spray nozzles or automatic sprinkler systems fitted with spray or fog nozzles are particularly satisfactory. The fine spray wets the dust and is not so likely to raise a dust cloud as with a solid stream. Portable extinguishers used to combat dust fires should be provided with similar devices for safe discharge.

3. Large hose of fire department size giving solid water streams should be used with caution; a dust cloud may be formed with consequent

be advised of this potential hazard in advance. Hose equipped with spray or fog nozzles should be provided and kept ready for an emergency.

4. Fires involving aluminum, magnesium, or some other metal powders are difficult to extinguish. Sand, talc, or other dry inert materials, and special proprietary powders designed for this purpose should be used. These materials should be applied gently to smother the fire. Materials such as hard pitch can completely seal the dust from oxygen and may be used. (See NFPA Code nos. 48, 65, and 651.)

ROCKET FUELS

by **Randolph T. Johnson**

Indian Head Division, Naval Surface Warfare Center

REFERENCES: Billig, *Tactical Missile Design Concepts*, Johns Hopkins Applied Physics Laboratory, *Technical Digest*, 1983, **4**, no. 3. Roth and Capener, *Propellants, Solid*, "Encyclopedia of Explosives and Related Items," Kave, ed., PATR 2700, vol. 8, U.S. Army Armament Research and Development Command, Dover, NJ, 1978. "Solid Propellant Selection and Characterization," NASA Design Criteria Guide, NASA SP 8064, 1971.

Until the development of the solid-fueled Polaris missile in the late 1950s and early 1960s, rocket motors tended to be divided into two distinct categories: rocket motors greater than 3 ft in diameter were liquid-fueled, while smaller rocket motors were solid-fueled. Since that time, a number of quite large rocket motors have been developed which use solid fuel; these include the Minuteman series and, most recently, the solid rocket boosters used on the space shuttle, each of which has over 1,000,000 lb of propellant. There are exceptions to the rule in the other direction, too; e.g., the air-launched Bullpup rocket motor started out as a liquid-fueled unit, changed to a solid fuel, then back to a liquid fuel.

Design Criteria

Before selecting the proper propellant system for a given rocket motor, the designer must consider the parameters by which the design is constrained. The following criteria generally need to be considered when choosing the propellant(s) for a given rocket motor:

Envelope Constraints The designer must consider the volume, mass and shape limits within which the rocket motor is constrained. For example, an air-launched rocket may be limited by the carrying capacity of the aircraft, the size of the launcher, and the size of the payload.

Performance Requirements In general, the requirements imposed on a rocket motor are expressed as the minimum required and/or the maximum allowed to complete the mission and the maximum allowed to prevent damage to the payload, launcher, etc. Such parameters include velocity, range, burn time, and acceleration.

Environmental Conditions The environments seen by various rocket motors differ dramatically, depending on the intended use. For example, a submarine-launched strategic missile lives a pampered life in near ideal conditions while a field-launched barrage rocket or an air-launched missile see near worse-case environments. Some of the parameters to consider in the choice of propellants include temperature limits of storage and operation, vibration and shock spectra to be experienced and survived, and the moisture and corrosion environments the rocket motor (and possibly the propellant) may be expected to encounter. It may be possible to reduce the effects of these environments on the propellant by rocket motor design, but the propellant chemist and the rocket motor designer must be willing to work together to come up with a viable combination.

Safety Requirements Safety considerations include toxic and explosion hazards in the manufacture of the rocket motor and in servicing, handling, and use. The use of the rocket must be considered in the safety margin built into its design. If it is to be used in a "human-rated" system, such as an ejection seat, it must be of more conservative design than if it were to be used in a barrage rocket, for instance.

Service Life The designer must consider the duration over which

the rocket motor will be in service. It is, in general, less expensive to make a number of rocket motors at a time and then store them, than to make the same number in several small lots over a period of time with the accordingly increased start-up and shutdown costs. A very short service life leads to heightened costs for repetitive shipping to and from storage, as well as rework and replacement of overaged units. There is yet another hidden cost of a very short service life: the risk that an overaged unit will be inadvertently used with potentially catastrophic results.

Maintenance The availability of maintenance will affect the choice of propellants for the given unit. The unit with readily available maintenance facilities will have far less severe constraints than the unit which must function after years of storage and/or far from the reach of service facilities.

Smokiness The choice of propellants must be influenced by whether or not the mission will allow the use of a propellant which leaves a smoky trail. Propellants containing a metal fuel, as well as certain other ingredients, leave a large smoky trail which reveals the location of the launch point. This is particularly undesirable in tactical rocket systems for it leaves the user revealed to the enemy. The smoke from metal fuels is termed **primary** smoke as it is a product of the primary combustion, **secondary** smoke comes from the reaction of propellant combustion products with the atmosphere, such as the reaction of hydrogen chloride with moisture in the air to leave a hydrochloric acid cloud, or water vapor condensing in cold air to leave a contrail.

Cost The cost of a rocket motor must be divided into a number of categories including design, test, ingredients, processing, components, surveillance, maintenance, rework, and disposal. The hidden cost of nonfunction (reliability) should also be factored into the equation.

Liquid Propellants versus Solid Propellants

The first choice to be made in the selection of propellants is whether to use a liquid or a solid propellant. Each of these comes with its own set of advantages and disadvantages which must be weighed in the selection process.

Liquid propellants offer the possibility of extremely high impulse per unit weight of propellant. The thrust of a liquid-propellant rocket motor may be easily modulated by controlling the flow rate of the propellant into the combustion chamber.

Liquid propellants, however, tend to be of low density, which leads to large packages for a given total energy. Most liquid propellants have a very limited usable temperature range because of freezing or vaporization. Because they require the use of valves, pipes, pumps, and the like, liquid-propellant rocket motors are relatively complex and require a high level of maintenance.

The use of liquid rocket propellants is predominant in older strategic rocket motors, such as Titan, and in space flight, such as the space shuttle main engines and attitude-control motors.

Solid propellants offer the possibility of use over a wide range of environmental conditions. They offer a significantly higher density than liquid propellants. Solid-propellant rocket motors are much simpler than liquid rocket motors, as the propellant grain forms at least one wall of the combustion chamber. This simplicity of design leads to low maintenance and high reliability. Safety is somewhat higher than with liquid propellants, for there are no volatile and hazardous liquids to spill during handling and storage.

Solid propellants, however, do not attain the impulse levels of the more energetic liquid propellants. Furthermore, once ignited, the thrust-time profile will be as dictated by the propellant surface history and propellant burn rate for the nozzle given; this profile is not easily altered, unlike that of a liquid-propellant rocket motor suitably equipped.

Solid-propellant rocket motors are now used in every size from small thrusters on the Dragon antitank round to the boosters on the space shuttle. They are used when a preprogrammed thrust-time history is appropriate.

Liquid Propellants Once the decision has been made to use liquid propellant, the designer is confronted with the decision of whether to use a monopropellant or a bipropellant system.

A **monopropellant** is a fuel which requires no separate oxidizer, but provides its propulsive energy through its own decomposition. The advantage of a monopropellant is the inherent simplicity of having only one liquid to supply to the combustion chamber. The principal disadvantage of the commonly used monopropellants is their very low impulse compared to most bipropellant or solid-propellant systems. Two of the more commonly used monopropellants are ethylene oxide and hydrogen peroxide.

Bipropellant systems use two liquids, an oxidizer and a fuel, which are merged and burned in a combustion chamber. There is a much wider selection of fuel constituents for bipropellant systems than for monopropellant systems. Bipropellants offer much higher impulse values than do the monopropellants, and higher than those available with solid propellants. The primary disadvantage of bipropellant systems is the need for a far more complex piping and metering system than is required for monopropellants.

Bipropellants may be subdivided further into two categories, **hypergolic** (in which the two constituents ignite on contact) and **nonhypergolic**. Hypergolic systems eliminate the need for a separate igniter, thus decreasing system complexity; however, this increases the fire hazard if the fuel system should leak.

When **cryogenic liquids** such as liquid hydrogen and liquid oxygen are used, the problems of storage become of major significance. A significant penalty in weight and complexity must be paid to store these liquids and hold them at temperature. Furthermore, these liquids charge a significant penalty, because their very low density enlarges the packaging requirements even more. This penalty is in the parasitic weight of the packaging and the increased drag induced by the increased skin area. These problems have limited the use of these propellants to systems where immediate response is not required, such as space launches, as opposed to strategic or tactical systems.

Fuels for bipropellant systems include methyl alcohol, ethyl alcohol, aniline, turpentine, unsymmetrical dimethylhydrazine (UDMH), hydrazine, JP-4, kerosene, hydrogen, and ammonia. **Oxidizers** for bipropellant systems include nitric acid, hydrogen peroxide, oxygen, fluorine, and nitrogen tetroxide. In some cases, mixtures of these will yield superior properties to either ingredient used alone; e.g., 50:50 mixture of UDMH with hydrazine is sometimes used in lieu of either alone.

Solid Propellants Once the decision has been made to use a solid propellant, one must decide between a case-bonded and cartridge-loaded propellant grain. The decision then must be made among composite, double-base, and composite modified double-base propellants.

Case-Bonded versus Cartridge-Loaded Case bonding refers to the technique by which the propellant grain is mechanically (adhesively) linked to the motor case. Cartridge-loaded propellant grains are retained in the motor case by purely mechanical means.

Case bonding takes advantage of the strength of the motor case to support the propellant grain radially and longitudinally; this permits the use of low-modulus propellants. This technique also yields high volumetric efficiency.

Since the propellant-to-case bond effectively inhibits the outer surface of the propellant, the quality of this bond becomes critical to the proper function of the rocket motor. This outer inhibition also tends to limit the potential propellant grain surface configurations, thus limiting the interior ballisticians' leeway in tailoring the rocket motor ballistics. Since the propellant grain is bonded to the motor case, the grain must be cast into the motor case or secondarily bonded to it. The former method leads to reduced flexibility in scheduling motor manufacture. The second technique can lead to quality control problems if a bare, uninhibited grain is bonded to the motor case, or to a loss in volumetric loading efficiency if a bare grain is inhibited or cast into a premolded form that is bonded to the motor case. Bonding the propellant grain to the motor case also makes it difficult to dispose of the rock motor when it reaches the end of its service life, especially in regard to making the motor case suitable for reuse.

Cartridge loading of the propellant grain offers flexibility of manufacture of the rocket motor, as the motor-case manufacture and propellant-grain manufacture may be pursued independently. This technique

also allows the interior ballisticians a free hand in configuring the propellant surface to obtain optimal ballistics. Since the propellant grain is held in the motor case mechanically, it is a simple matter to remove the propellant at the end of its service life and reuse the motor case and associated hardware.

The cartridge-loaded propellant grain must be inhibited in a separate operation, as opposed to the case-bonded grain. The free-standing grain must be supported so that it is not damaged by vibration and shock; correspondingly, the propellant must have substantial strength of its own to withstand the rigors of the support system and the vibrations and shocks that filter through the system. The presence of the mechanical support system and the inhibitor, and the space required to slide the propellant grain into the motor case, prevent the cartridge-loaded propellant grain from having the volumetric loading efficiency of a case bonded propellant grain.

Composite versus Double-Base versus Composite Modified Double-Base Composite propellants consist primarily of a binder material such as polybutadiene (artificial rubber) and finely ground solid fuels (such as aluminum) and oxidizers (such as ammonium perchlorate). Double-base propellants consist primarily of stabilized nitrocellulose and nitroglycerine. Composite modified double-base propellants use a double-base propellant for a binder, with the solid fillers commonly found in composite propellants.

Composite propellants offer moderately high impulse levels and widely tailorable physical properties. They may be designed to function over a wide range of temperatures and, depending upon the fillers, have high ignition temperatures and consequently very favorable safety features.

Composite propellants at the present time are limited to cast applications. The binders are petroleum-based, and subject to the vagaries of oil availability and price. Many of the formulations for their binders contain toxic ingredients as well as ingredients which are sensitive to moisture. The water sensitivity carries over to the filler materials which tend to dissolve or agglomerate in the presence of moisture in the air. Composite propellants also are notoriously difficult to adequately inhibit once the propellant has fully cured.

Historically, a number of binder materials have been used in the manufacture of composite propellants. Among these are asphalt, polysulfides, polystyrene-polyester, and polyurethanes. Propellants of recent development have been predominantly products of the polybutadiene family: carboxy-terminated polybutadiene (CTPB), hydroxy-terminated polybutadiene (HTPB), and carboxy-terminated polybutadiene-acrylonitrile (CTBN). It should be pointed out that the binder material also serves as a fuel, so a satisfactory propellant for many purposes may be manufactured without a separate fuel added to it. While the addition of metallic fuels to the propellant significantly increases the energy of the propellant, it also produces primary smoke in the form of metal oxides. The most commonly added metal is aluminum, but magnesium, beryllium, and other metals have been tried. The most commonly used oxidizer (which makes up the preponderance of the weight of the propellant) is ammonium perchlorate. Other oxidizers which have been used include ammonium nitrate, potassium nitrate, and potassium perchlorate.

Double-base propellants have been used in guns since Alfred Nobel's discovery of ballistite in the nineteenth century. Their first significant use in rocketry came during World War II in barrage rockets. All our modern double-base propellants are descended from JPN, of World War II vintage. These propellants may be cast or extruded, use relatively nontoxic ingredients which are relatively insensitive to water, do not use petroleum derivatives to any appreciable extent, and are easily inhibited by solvent bonding an inert material to the surface of the propellant. It is possible to attain very low temperature coefficients of burn rate with these propellants; it is also possible to attain a double-base propellant which declines in burn rate with pressure over a portion of its usable pressure range, as opposed to the more usual monotonic increase in burn rate. This "mesa" burning, as it is called, allows the interior ballisticians to more easily stabilize the pressure and thrust of the rocket motor.

Double-base propellants tend to have low to moderate impulse levels and are limited in temperature range not only by a high glass transition temperature, but also by their tendency to soften, liberate nitroglycerine, and decompose at higher temperatures. These propellants tend to auto-ignite at low temperatures and tend to be explosive hazards. Their physical properties are essentially fixed by the properties of nitrocellulose and are not easily tailored to changing requirements.

Double-base propellants contain nitrocellulose of various nitration levels (usually 12.6 percent nitrogen), nitroglycerine, and a stabilizer. Various inert plasticizers are added to modify either the flame temperature or the physical properties of the propellant.

Composite modified double-base propellants offer the highest energy levels presently available with solid propellants. This energy comes at an extremely high price, however: the storage and operating temperature limits only differ from minimum to maximum by about 20°F. These propellants are also extremely shock-sensitive and have very low auto-ignition temperatures. They are limited in use to systems such as submarine-launched ballistic missiles, where the temperature and vibration conditions are closely controlled. Classically, these compositions have contained nitrocellulose, nitroglycerine, aluminum, ammonium perchlorate, and the explosive HMX, which serves both as an oxidizer and gas-producing additive.

Propellant Properties and Interior Ballistics

The thrust and pressure profiles of a rocket motor must be controlled in order to meet the design criteria noted earlier. With liquid and solid propellants, the nominal controls differ dramatically, but in the elimination of spurious pulses and the control of nozzle erosion, the two types of propellant are more similar than different.

Pressure and Thrust Control In design of a liquid-propellant rocket motor, the prime considerations are properly sizing the combustor and nozzle and metering the propellant flow to attain the desired thrust. If variations in thrust are desired, these may be carried out either through preprogramming the flow by orifice size or by pump pressure; similarly, the flow may be varied on command by the operator.

The situation with a solid rocket motor is less clear-cut. The rate of gas generation inside the rocket motor is controlled by the burn rate of the propellant and the amount of burn surface available.

The burn rate of the propellant may be varied by the addition of various chemical catalysts; iron compounds are sometimes added to composite propellants and lead compounds to double-base propellants in order to speed burning. Coolants such as oxamide are added to composite propellants and inert plasticizers are added to double-base propellants to slow burn rates. The burn rate of composite propellants may be changed by changing oxidizers or by modifying the size distribution of the oxidizer. In efforts to achieve ultra-high burn rates, silver or aluminum wires have been added to propellants to increase heat conduction and so speed burning.

The surface area of a propellant grain is controlled by its shape and by

the amount and areas in which the propellant grain is inhibited. This surface area tends to change in configuration as the propellant burns. The propellant grain designer must evolve a grain configuration which yields the desired pressure-time and thrust-time history. Most often, the objective in grain design is to achieve a neutral to slightly regressive (constant to slightly decreasing) thrust-time history.

In some cases (as where a high-thrust phase is to be followed by a low- to moderate-thrust phase), it is necessary to develop a grain or grains with varying geometries and/or varying burn rates to achieve the desired thrust-time profile. These results may require such techniques as using tandem or coaxial grains with different geometries and/or different burn rates and perhaps different propellants.

The pressure within the combustion chamber depends not only on the rate of combustion, but also on the size of the nozzle throat. Throat size tends to decrease with heating, but the surface tends to wear away with the hot gases and embedded particles eroding material from the surface of the throat and nozzle exit cone. In some cases, this loss of material may serve to assist the interior ballistics in the quest for the ideal thrust-time profile.

Combustion Instability Rocket motors are sometimes given to sudden, erratic pressure excursions for a number of reasons. Liquid-propellant fuel may surge; solid propellant grains may crack; material may be ejected from the motor and temporarily block the nozzle. Sometimes these excursions cannot be explained by any of the above possibilities, but will be attributed to "unstable combustion." The causes of unstable or "resonant" combustion are still under investigation.

A number of techniques have been developed to reduce or eliminate the pressure excursions brought on by unstable combustion, but there is, as yet, no panacea.

Nozzle Erosion As the propellant gases pass out of the rocket motor through the nozzle, their heat is partially transferred to the nozzle. The heated nozzle material softens and tends to be eroded by the mechanical and chemical action of the propellant gases. The degree of erosion is heightened when a metal fuel is added to the propellant gases, particulate matter is contained in the gases, the gases are corrosive, or the propellant gases are oxidizing.

One technique widely used in reducing nozzle erosion is to add coolant to the propellant formulation. Ablatives are sometimes added to the nozzle or chamber ahead of the nozzle throat; gases generated by the ablating material form a boundary layer to protect the nozzle from the hot propellant gases in the core flow. In liquid propellant rockets, the fuel (where stability permits) may be used as a coolant fluid. Nozzle inserts are probably the most commonly used technique to limit nozzle erosion. The nozzle shell is usually made of aluminum or steel when inserts are used and the nozzle throat is made of heat-resistant material. For a small amount of permissible erosion, carbon inserts are used; when no erosion is acceptable, tungsten or molybdenum inserts are used.

7.2 CARBONIZATION OF COAL AND GAS MAKING

by Klemens C. Baczewski

REFERENCES: Porter, "Coal Carbonization," Reinhold, Morgan, "Manufactured Gas," J. J. Morgan, New York. *BuMines Monogr.* 5 and other papers. Powell, "Future Possibilities in Methods of Gas Manufacture," and Russell, "The Selection of Coals for the Manufacture of Coke," papers presented to the AGA Production and Chemical Conference, Wilson and Wells, "Coal, Coke and Coal Chemicals," McGraw-Hill. Elliott, High-Btu Gas from Coal, *Coal Utilization*, Dec. 1961. Osthaus, Town Gas Production from Coal by the Koppers-Totzek Process, *Gas and Coke*, Aug. 1962. "Clean Fuels from Coal Symposium," IGT, Sept. 1973. Kirk-Othmar, "Encyclopedia of Chemical Technology," 2d ed., Barker. Possible Alternate Methods for the Manufacture of Solid Fuel for the

Blast Furnace, *Jour. Iron Steel Inst.*, Feb. 1971. Potter, Presidential Address, 1970, Formed Coke, *Jour. Inst. Fuel*, Dec. 1970, International Congress, Coke in Iron and Steel Industry, Charleroi, "1966 Gas Engineers Handbook," The Industrial Press. *Quarterly Coal Reports* 1982, 1983, U.S. Department of Energy. Elliott, "Chemistry of Coal Utilization," 2d supp. vol., Wiley, 1981. Davis, Selection of Coals for Coke Making, *U.S. BuMines Rep. Inv.* 3601, 1942. Wolfson, Birge, and Walters, Comparison of Coke Produced by BM-AGA and Industrial Methods, *U.S. BuMines Rep. Inv.* 6354, 1964. Iron and Steel Society, Inc., *Iron-making Conf. Proc.*, 1988, 1992, 1993; "Marks' Standard Handbook for Mechanical Engineers," 9th ed., McGraw-Hill.

Carbonization of coal, or the breaking down of its constituent substances by heat in the absence of air, is carried on for the production of coke for metallurgical, gas-making, and general fuel purposes; and gas of industrial and public-utility use. Coal chemicals recovered in this country include tar from which are produced crude chemicals and materials for creosoting, road paving, roofing, and waterproofing; light oils, mostly benzene and its homologues, used for motor fuels and chemical synthesis; ammonia, usually as ammonium sulfate, used mostly for fertilizer; to a lesser extent, tar acids (phenol), tar bases (pyridine), and various other chemicals. Developments in new designs, pollution control equipment, and the production of formed coke are discussed.

Gas making, as treated here, includes gas from coal carbonization, gasification of solid carbonaceous feedstocks via fixed and fluid-bed units, gasification in suspension or entrainment, and gasification of liquid hydrocarbons.

CARBONIZATION OF COAL

Coke is the infusible, cellular, coherent, solid material obtained from the thermal processing of coal, pitch, and petroleum residues, and from some other carbonaceous materials, such as the residue from destructive distillation. This residue has a characteristic structure resulting from the decomposition and polymerization of a fused or semiliquid mass. Specific varieties of coke, other than those from coal, are distinguished by prefixing a qualifying word to indicate their source, such as "petroleum coke" and "pitch coke." A prefix may also be used to indicate the process by which coke is manufactured, e.g., "coke from coal," "slot oven coke," "beehive coke," "gashouse coke," and "formcoke." See Table 7.2.1.

High-temperature coke, for blast-furnace or foundry use, is the most common form in the United States. In 1982, almost 100 percent of the production of high-temperature coke was from slot-type ovens, with minimal quantities being produced from nonrecovery beehive and other types of ovens. Blast furnaces utilized 93.1 percent; foundries, 4.3 percent; and other industries, the remainder. **Low- and medium-temperature cokes** have limited production in the United States because of a limited market for low-temperature tar and virtually no market for the coke.

The following data on the properties of **blast-furnace coke** were obtained from a survey of plants representing 30 percent of the U.S. production; volatile matter of the cokes ranged from 0.6 to 1.4 percent; ash, from 7.5 to 10.7 percent; sulfur, from 0.6 to 1.1 percent; 2-in shatter index, from 59 to 82; 1½-in shatter index, from 83 to 91; 1-in tumbler (stability factor), from 35 to 57; and ¼-in tumbler (hardness factor), 61 to 68. Comparison of this survey with a prior survey made in 1949 indicates that the quality of blast-furnace coke has been improved by reducing the ash and sulfur contents and increasing the average ASTM tumbler stability from 39 to 52. The tumbler stability is the principal index for evaluating the physical properties of blast-furnace coke in the United States. Other tests for determining the physical properties of blast-furnace and foundry cokes that are cited in export specifications are the MICUM, IRSID, ISG, and JIS methods.

During the coking process, several additional products of commercial value are produced. If the plant is large enough to recover these products, their value can approach 35 percent of the coal cost. The more

valuable products are fuel gas with a heating value of 550 Btu/ft³ (20,500 kJ/m³); tar and light oils that contain benzene, toluene, xylene, and naphthalene; ammonia; phenols; etc.

The requirements for **foundry coke** are somewhat different from those for blast-furnace coke. Chemically, in the cupola the only function of the coke is to furnish heat to melt the iron, whereas in the blast furnace the function is twofold: to supply carbon monoxide for reducing the ore and to supply heat to melt the iron. Foundry coke should be of large size (more than 3 in or 75 mm) and strong enough to prevent excessive degradation by impact of the massive iron charged into the cupola shaft. The following characteristics are desired in foundry coke: volatile matter, not over 2 percent; fixed carbon, not under 86 percent; ash, not over 12 percent; and sulfur, not over 1 percent. In the coke production survey, foundry coke from two plants showed the following properties; volatile matter, 0.6 and 1.4 percent; fixed carbon, 89.6 and 91.4 percent; ash, 8.7 and 7.5 percent; and sulfur, 0.6 percent. The 1½- and 2-in shatter indexes, which are a measure of the ability of coke to withstand breakage by impact, were 98 and 97, respectively, for both cokes.

Pitch coke is made from coal tar pitch, whereas **petroleum coke** is made from petroleum-refining residues. Both are characterized by high-carbon and low-ash contents and are used primarily for the production of electrode carbon. Coke consumption in the United States was approximately 29.2 million tons in 1989 and 23.9 million tons in 1993. The major user is blast-furnace operations, with others using 100,000 tons. (American Iron and Steel Inst., Annual Statistical Report, Washington, 1993). This trend is expected to continue as electric-arc furnace (EAF) use increases and as direct reduction and coal injection systems are installed. (*Chem. Engrg.*, March 1995, p. 37.)

High-temperature carbonization or coking is carried on in ovens or retorts with flue-wall temperatures of ± 1,800°F (980°C) for the production of foundry coke and up to ± 2,550°F (1,400°C) for the production of blast-furnace coke. Typical yields from carbonizing 2,204 lb [1.0 metric ton (t)] of dry coal, containing 30 to 31 percent volatile matter, in a modern oven are: coke, 1,590 lb (720 kg); gas, 12,350 ft³ (330 m³); tar, 10 gal (37.85 L); water, 10.5 gal (39.8 L); light oil, 3.3 gal (12.5 L); ammonia, 4.9 lb (2.22 kg).

Coal Characteristics Despite the vast coal reserves in the United States, most of the coal is not coking coal. Coking coals are only those coals which, according to the ASTM classification by rank, fall into the class of bituminous coal and are in the low-volatile, medium-volatile, high-volatile A or high-volatile B groups and which, when heated in the absence of air, pass through a plastic state and resolidify into a porous mass that is termed coke. In determining if an unknown coal is a **coking coal**, prime importance is placed upon obtaining a freshly mined sample since all coking coals experience oxidation or weathering which can cause a loss in coking ability.

Laboratory tests are used by coal investigators to determine if particular coals have coking properties and how they can best be used to make coke. The most common of these tests is **proximate analysis** (ASTM D3172), which provides the coal rank and ash content. It is desirable to have low ash coals (below 8 percent), since the ash does not contribute to the blast furnace or foundry processes. **Sulfur content** (ASTM D3177) passes through the coking process and appears in the final coke and in the evolved gases during coking. High sulfur contents (above 1.0 per-

Table 7.2.1 Analyses of Cokes

Coke type	"As-received" basis									
	Proximate, %				Ultimate, %					High heat value, Btu/lb†
	Moisture	Volatile matter	Fixed carbon	Ash*	Hydrogen	Carbon	Nitrogen	Oxygen	Sulfur	
By-product coke	0.4	1.0	89.6	9.0	0.7	87.7	1.5	0.1	1.0	13,200
Beehive coke	0.5	1.2	88.8	9.5	0.7	87.5	1.1	0.2	1.0	13,100
Low-temperature coke	0.9	9.6	80.3	9.2	3.1	81.0	1.9	2.8	1.0	12,890
Pitch coke	0.3	1.1	97.6	1.0	0.6	96.6	0.7	0.6	0.5	14,100
Petroleum coke	1.1	7.0	90.7	1.2	3.3	90.8	0.8	3.1	0.8	15,050

* Ash is part of both the proximate and ultimate analyses.

† Btu/lb × 2.328 = kJ/ke.

cent) affect the iron quality and require additional gas processing for removal. **Free-swelling index** (ASTM D720) is a fast method to determine if a coke will form a coherent mass. Some observers feel the size of the "button" produced is important while others use it only as a screening device. **Gieseler plastomer** (ASTM D2639) is the most popular of several dilatometer testers which measure the fluid properties of the coal through the plastic state and into the solidification phase. It is generally agreed that the test is useful, although some investigators feel it only indicates that a coal is coking. Others feel that the temperatures at which the coal begins to soften and then resolidify serve as guides to establish which coals are suitable for blending. Still others couple the use of these data with petrographic analysis to predict coke strengths of various blends. While Gieseler is widely used in the United States, two other methods, Audibert-Arnu and the Ruhr test, are frequently used throughout the world. **Petrographic composition** is determined by the examination of coal under a microscope. Results were first reported in 1919 but it was not until 1960 that a method for predicting coke strength was introduced by Schapiro and Gray (Petrographic Constituents of Coal, *Illinois Mining Institute Proc.*, 1960); it has become an important and popular test for the selection of coal for coke manufacturing. The method consists of determining which portion of the coal becomes plastic during heating (reactive entities) and which portion does not undergo plastic change (inert entities). These observations are then correlated with pilot oven tests and are used to predict coke strength.

Coal Blending The use of a single coal to produce strong metallurgical coke without resultant high coking pressures and oven wall damage is very rare, and coke producers rely on the blending of coals of varying coking properties to produce strong coke. It is common practice in the coking industry to mix two or more coals to make a better grade of coke or to avoid excessive expansion pressures in the oven. One coal is usually of high volatile content (31 to 40 percent) and the other of low volatile content (15 to 22 percent). The amount of low-volatile coal in the mixture is generally in the range of 15 to 25 percent although as much as 50 percent may be used in mixtures for producing foundry coke. High-volatile coals tend to shrink during coking, while low-volatile coals tend to expand. Examinations of the plastic properties of coals when heated are valuable in selecting the best types for blending. Because of the risks of oven wall damage from unknown coal mixtures, most operators will not rely solely on laboratory tests but will insist on some pilot-scale oven testing.

Pilot-Scale Tests A number of designs of pilot-scale ovens which closely approximate commercial coke ovens have been developed. A few have been used solely to produce coke for testing but most have been designed with one fixed wall and one movable wall so that data about carbonization pressures in the oven during coking can be collected while making coke for testing. These ovens usually hold between 400 and 1,000 lb (180 to 450 kg) of coal. Another test oven in use was developed by W. T. Brown (*Proc. ASTM*, 43, 1943, pp. 314–316) and differs from the movable wall oven by applying a constant pressure on the charge while heating the coal from only one side.

The European Cokemaking Technology Center (EEZK, Essen Germany) has operated a mini-jumbo reactor, which has a chamber width of 34 in (864 mm) and length and height of 40 in (101.6 mm). A demonstration facility, the Jumbo Coking Reactor, is operational, at 100 mt/d. The chambers of this unit are 34 in (864 mm) wide, 32.8 ft (10 m) high, and 65.6 ft (20 m) long. The concept of such large chambers is supported by full-scale tests conducted on 17-, 24-, and 30-in-wide (450-, 610-, and 760-mm-wide) ovens and is based on preheated coal charging. (Bertling, Rohde, and Weissiepe, *51st Ironmaking Conf. Proc.*, Toronto, Apr. 1992.)

Coking Process Coal produces coke because the particles of coal soften and fuse together when sufficiently heated. Initial softening of the coal, as determined by plastometer tests, occurs at 570 to 820°F (300 to 440°C). At or near the softening temperature gases of decomposition begin to appear in appreciable quantities, gas evolution increasing rapidly as the temperature is raised. This evolution of gases within the plastic mass causes the phenomenon that finally results in the cellular structure which is so characteristic of coke. Further temperature

increase and decomposition cause hardening into coherent porous coke.

As a result of the low thermal conductivity of coal (less than one-sixth of that of fire clay), and also of semicoke, heat penetrates slowly into the pieces and through the plastic layer; uniform plasticity or complete coalescence does not appear until the temperature (at the heated side of a softening layer) is considerably higher than the softening point of the coal. (See Fig. 7.2.1.)

The **plastic zone** moves slowly from the hot wall of the oven toward the center, at a rate first decreasing with the distance from the wall and then increasing again at the middle of the oven. For several hours after charging a red-hot oven, the center of the charge remains cool. The plastic layer's temperature variation, from one border to the other, is from 700 to 875°F (370 to 468°C), and its thickness is $\frac{3}{8}$ to $\frac{3}{4}$ in depending on the coal, the charge density, and the oven temperature.

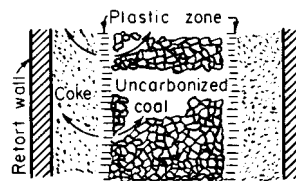

Fig. 7.2.1 Diagrammatic illustration of the progress of carbonization and of composition of the plastic zone.

In the modern coal-chemical-recovery coke oven, the average rate of travel of the plastic zone is about 0.70 in (17.8 mm) per h, and the average **coking rate**, to finished coke in the center, is 0.50 to 0.58 in (12.7 to 14.7 mm); i.e., a 17-in (432-mm) oven may be run on a net coking time of 16 to 17 h. (See Fig. 7.2.2.)

New designs of wide ovens with chamber widths of 21.6 in (550 mm) have been built. The coking time increases slightly, to about 23 h, but not in proportion to the width increase. (Beckmann and Meyer, *52d Ironmaking Conf. Proc.*, Dallas, Mar. 1993.)

The gases and tar vapors travel chiefly outward toward the wall from the plastic layer and from the intermediate partly coked material, finding exit upward through coke and semicoke. Exit through the center core of uncoked coal, except for a very small fraction of the early formed gases, is barred by the relative impermeability of the plastic layer. The final chemical products, including gas, are the result of secondary decompositions and interreactions in the course of this travel.

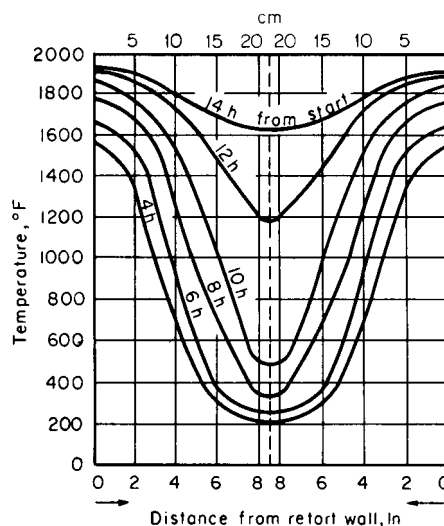

Fig. 7.2.2 Temperature gradients in a cross section of a coal-chemical-recovery coke oven, 17 in wide, at about middepth on a 17-h coking time.

Average temperatures in various parts of the carbonizing system, for modern rapid coal-chemical-recovery oven operation, are about as follows: heating flues, at bottom, 2,500 to 2,600°F (1,370 to 1,425°C); heating flues, upper part, 2,150 to 2,450°F (1,175 to 1,345°C); oven wall, inner side (average final), 1,850 to 2,100°F (1,010 to 1,150°C).

Temperature Effects during Carbonization In industrial carbonizing, higher temperatures at the oven wall and in the outer layers of the charge produce higher gas yield and less tar. The gases and tar vapors change in quality and quantity continuously during the carbonizing period. The percentage content of hydrocarbons and condensables in the oven gases decreases and that of hydrogen increases. Passage through the highly heated free space above the charge has the effect of increasing the yield of gas and light oil (reducing, however, the toluene and xylenes) and lowering tar yield, with increase of naphthalene, anthracene, and lowering tar yield, with increase of naphthalene, anthracene, and free carbon. Modern ovens tend to exercise control of the temperature in this free space. The rate of decomposition of ammonia increases above 1,450°F (788°C).

The progressive change in gas yield and composition during the carbonizing period for a good gas-making coal is about as in Table 7.2.2. Some gas yields and composition are shown in Table 7.2.3.

The overall thermal efficiency of industrial coal carbonization (useful recovery of heat from total input of heat) is between 86 and 92 percent approx. External sensible-heat efficiencies are between 65 and 80 percent approx. Typical heat balances on coal-chemical-recovery ovens are shown in Table 7.2.4.

Heat Used for Carbonization The total heating value of the gas burned in the flues to heat the ovens varies from 950 to 1,250 Btu/lb (528 to 695 kcal/kg) of wet coal carbonized in efficient installations depending on the heat required by the individual coals in the blend. Producer and blast-furnace gases are called lean gases. When underfiring with lean gas, both air and gas are regenerated (preheated) in order to get sufficient flame temperature for the flues. Natural, refinery, and I.P. gases have been used to a limited extent for underfiring. These and coke-oven gas are rich gases and are not preheated, as their flame tem-

Table 7.2.4 Heat Balance as a Function of the Volatile Matter Content*

	% Volatile matter (DAF)			
	23.8	26.5	28.7	33.2
Moisture, %	10.6	10.3	9.7	10.1
Consumption of heat, kcal/kg	492	496	522	559
Waste-gas loss, %	10.9	10.7	10.8	9.6
Surface loss, %	10.1	9.9	9.5	8.8
Total loss, %	21.0	20.6	20.3	18.4
kcal/kg	103.3	102.2	106.0	102.9
Effective heat (heat of coking), kcal/kg	388.7	393.8	416.0	456.1
Sensible heat in coke, kcal/kg	284.1	278.2	281.0	260.2
Sensible heat in gas, kcal/kg	144.1	152.3	164.9	188.3
Total sensible heat, kcal/kg	428.4	430.5	445.9	448.5
Heat of reaction (exothermic)	+ 39.7	+ 36.7	+ 29.9	- 7.6

The heat of reaction is the difference between effective heat and loss by sensible heats.
* W. Weskamp, Influence of the Properties of Coking Coal as a Raw Material on High Temperature Coking in Horizontal Slot Ovens, *Glückauf*, **103** (5), 1967, 215-225.

peratures are sufficiently high and regeneration would crack their hydrocarbons. Air is preheated in all cases.

CARBONIZING APPARATUS

The current trend in design of coal-chemical-recovery coke ovens is to larger-capacity ovens and improved, oven-wall liner brick and wall design to afford increased heat transfer from the heating flues to the oven chamber. Formerly, ovens were usually about 40 ft (12 m) long and from 12 to 16 ft (3.7 to 5.0 m) high. Modern ovens are about 50 ft (15 m) long and 20 to 23 ft (6 to 7 m) high and hold a charge of 35 tons (32 mt) or more. Average oven width is 16 to 19 in (400 to 475 mm), usually 18 in (450 mm), with a taper of 3.0 to 4.5 in (75 to 115 mm) from the pushing end to the coke-discharge end of the oven. New de-

Table 7.2.2 Variation in Gas Yield during Carbonization

Period	Volume m ³ /Mt	kcal/m ³	Volume ft ³ /ton	Btu/ft ³	Approx composition, %		
					Hydrocarbons	Hydrogen	Oxides of carbon
First quarter	1,130	5,800	3,630	651	41	46	7
Second quarter	1,000	3,400	3,190	610	37	53	7
Third quarter	1,010	5,050	3,250	567	32	59	6
Fourth quarter	585	3,230	1,875	363	8	82	5

Table 7.2.3 Gas Yields and Composition from Various Coal Types with High-Temperature Carbonization

Coal	Temp in inner wall, °F (°C)	Gas yield, ft ³ /ton (m ³ /Mt)	Gas composition, %						
			Carbon dioxide	Carbon monoxide	Unsat'd hydro- carbons	Methane	Ethane, etc.	Hydrogen	Nitrogen
Pittsburgh bed, Fayette Co., Pa., V.M.* 33.6	1,950 (1,065)	11,700 (365)	1.3	6.8	3.2	31.1	0	56.5	1.1
Elkhorn bed, Letcher Co., Ky., V.M. 36.6	1,950 (1,065)	11,500 (358)	1.1	7.7	4.0	31.0	0.2	55.0	1.0
Sewell bed, W. Va., V.M. 26.5	1,950 (1,065)	12,000 (375)	0.7	5.5	2.5	26.5	0	64.8	1.0
Pocahontas no. 4, W. Va., V.M. 16.4	1,950 (1,065)	11,900 (372)	0.4	5.0	1.1	18.0	0	75.0	0.5
Illinois, Franklin Co., V.M. 32.1	1,950 (1,065)	12,000 (375)	3.8	14.5	2.8	21.0	0	56.9	1.0
Utah, Sunnyside, V.M. 38.8	1,950 (1,065)	12,600 (394)	3.0	14.5	3.7	26.0	0.5	51.3	1.0

*V.M. = percentage of volatile matter.

signs, tending toward larger ovens, have been built with oven widths from 21.6 to 24.0 in (550 to 610 mm), 24.75 ft (7.85 m) high, and 54 ft (16.5 m) long. Coke production of the 21.6-in oven is about 47.3 tons (43 mt) per charge. The larger oven yields more coke per push, reducing environmental problems while increasing productivity (Hermann and Schonmuth, *52d Ironmaking Conf. Proc.*, Detroit, Mar. 1993; Beckman and Meyer, op. cit.).

Various oven designs are used, distinguished chiefly by their arrangements of the vertical heating flues and wasteheat ducts. Two basic designs are used for heating with rich gas (coke-oven gas): (1) the gun-flue design wherein the fuel gas is introduced via horizontal ducts atop the regenerators and thence through nozzles which meter the gas into the vertical flues, and (2) the underjet design which incorporates a basement, located underneath the regenerators, in the battery structure. Horizontal headers running parallel with the vertical heating walls convey the fuel gas via riser pipes through the regenerators to the vertical heating flues. One design recirculates waste combustion gas from the adjacent heating wall through a duct underneath the oven and regenerator by the jet action of the fuel gas through specially designed nozzles. This provides a leaner gas at the place combustion occurs and affords a more even vertical heat distribution for tall ovens. Designs for lean gas (blast-furnace gas, producer gas) employ sole flues beneath the regenerators for introducing the fuel gas. Ports control the quantity of gas fed from the sole flues into the regenerators. To prevent equalization of gas distribution after the gas leaves the sole flues, the regenerator chambers are divided into compartments. All modern ovens use regenerators for preheating the combustion air and lean gas. Average wastegas (stack) temperatures range from 450 to 700°F (230 to 370°C).

Coke ovens are built in batteries of 15 to 106 and arranged so that each row of heating flues, or wall, heats half of two adjacent ovens. Modern practice is to build batteries of the maximum number of ovens in a single battery that can be operated by a single work crew to optimize productivity. This is in the range of 79 to 85 ovens per battery. Coal is charged from a larry car through openings in the top of the oven. After coking, doors are removed from both ends of the oven and coke is pushed out of the oven horizontally by a ram operated by a pusher machine. Gas is removed continuously at constant pressure (few millimeters of water column) via oven standpipes connected to a gas collecting main.

Computerized control is being used for new facilities and is being applied to existing ones to improve efficiency. This integrates control of variables such as charge weight and moisture, excess combustion air, flue temperature, and coke temperature. The performance improvement in one case was the reduction in heating requirements from about 1,500 Btu/lb (832 Kcal/kg) dry coal to under 1,200 Btu/lb (666 Kcal/kg) dry coal and the stabilization of coking times, ranging from 18 to 40 to 24 h (Pfeiffer, *47th Ironmaking Conf. Proc.*, Toronto, Apr. 1988).

Coal Chemical Recovery The gas is first cooled in either direct or indirect coolers which condense most of the tar and water from the gas. Some ammonia is absorbed in the water, forming a weak ammonia liquor. Exhausters (usually centrifugal) follow and operate from 6- to 12-in (150- to 300-mm) water column suction at the inlet to 50- to 80-in (1,250- to 2,000-mm) pressure discharge. Electrical precipitators remove the last traces of tar fog. The gas, combined with ammonia vapor stripped from the weak ammonia liquor, then passes through dilute sulfuric acid in saturators or scrubbers which recover the ammonia as ammonium sulfate. Phosphoric acid may be used as the absorbent to recover the ammonia as mono- or diammonium phosphate. Low-cost synthetic ammonia produced via reforming of natural gas and hydrocarbons has made recovery of coke-oven ammonia uneconomical. Some recent coke plants have been designed with ammonia destruction units.

After direct cooling with water, which removes much of the naphthalene from the gas, the gas is scrubbed of light oil (benzol, toluol, xylol, and solvents) with a petroleum oil. The enriched petroleum oil is stripped of the light oil by steam distillation, and the light oil is usually sold to the local oil companies. Only a few coke plants continue to refine light oil. Phenols and tar acids are recovered from the ammonia liquor and tar. Pyridine and tar bases are recovered

from the ammonia saturator liquor and tar. Distillation of the tar produces cresols, naphthalene, and various grades of road tar and pitches. Acid gases (hydrogen sulfide, hydrogen cyanide) are removed from the gas. The hydrogen sulfide is converted to elemental sulfur. The cyanogen may be recovered as sodium cyanide.

Pollution Control Enactment of pollution-control laws has motivated many developments of control devices and new operating techniques. The continuous emissions caused by leakage from oven doors, charging hold lids, standpipe lids, and oven stacks are being controlled by closer attention to operations and maintenance. Emissions from charging are being contained by the use of a second collecting main, jumper pipes and U-tube cars.

Pushing emissions equipment includes hood duct arrangements with wet scrubbers or baghouses, mobile hoods with wet scrubbers, and coke side enclosures with baghouses. There has been much interest in Japan and the Soviet Union in dry quenching of coke with inert gases for pollution control and coke quality improvements, but so far in the United States the capital and maintenance costs have dampened any enthusiasm for dry quenching. In the coal chemical plant area, proposed laws for benzene emissions will require many plants to revise and rebuild major portions of their equipment. Sulfur emissions standards have caused most plants to install sulfur recovery equipment.

Systems for charging **preheated coal** into coke ovens by either pipeline (Marting and Auvil, Pipeline Charging Preheated Coal to Coke Ovens, UNEC Symposium, Rome, Mar. 1973), hot conveyors, or hot larry cars have been built to eliminate charging emissions, improve oven productivity, and to use larger amounts of weakly coking coals. It appears that the economics are positive only if very poor and cheap coking coals are available. No systems are operating in the United States because good coking coal is readily available. The Japanese have looked at preheating of coal and have decided that it is more effective to **briquette** a portion of the poorer-quality coals and mix them with the normal coal mixture being charged to the ovens. Briquettes usually make up about 30 percent of the blend, and many Japanese plants have adopted a form of briquette blending. Preheating is becoming important again in the development of wider ovens and jumbo reactors, which are based on using this technique.

Form coke, the production of shaped coke pieces by extrusion or briquetting of coal fines followed by carbonization, has been practiced for many years in the United Kingdom and Europe to provide a "smokeless" fuel primarily for domestic heating. Form coke for use in low shaft blast furnaces is produced commercially from brown coal (lignite) at large plants in Lauchhammer and Schwarze-Pumpe, East Germany. As much as 60 to 70 percent of form coke is used in combination with conventional slot oven coke.

A major development is **FMC coke process** which is operating commercially at the FMC plant in Kemmerer, Wyoming. The facility is producing coke for use in the elemental phosphorus plant in Pocatello, Idaho. The process produces a low-volatile char, called **calcinate**, and a pitch binder. Crushed coal is dried, carbonized, and calcined at successively higher temperatures, while solids flow continuously through a series of fluid-bed reactors. Operating temperatures range from 300 to 600°F (150 to 315°C) in the first bed to 1,500 to 2,200°F (815 to 1,200°C) in the third. The calcinate is cooled before being mixed with the pitch binder. The mix is briquetted into pillow shapes up to 2-in sizes and is sent to curing ovens to be devolatilized and hardened into the finished coke product. Off-gases from all systems are cooled and cleaned, recycling dusts into the process to be included in the product. Cleaned gases have a heating value of 100 to 140 Btu/SCF (890 to 1,240 kcal/m³) and can be used as best suit the local conditions. Typically, it is fuel for process needs, and for steam generation, while residual gas can be used in cogeneration applications.

The process is continuous, and fully contained, so that environmental controls can be met with conventional equipment. The Kemmerer plant fully meets EPA and OSHA regulations. Coal types suitable for processing include lignites and extend to anthracites. Different volatility, fluidity, and swelling characteristics can be accommodated by appropriate adjustment of operating parameters. This permits the use of non-

metallurgical coals for coke production. The coke product has been tested in blast furnaces for many years. A major effort was the 20,000-ton trial at Indiana Harbor Works of Inland Steel by a consortium of steel companies. Furnace operation was normal up to 50 percent of FMC product in the coke burden, with indications that higher proportions would also be satisfactory. The process is illustrated in Fig. 7.2.3. (FMC personal communications)

The **Bergbau-Forschung process** [Peters, Status of Development of Bergbau-Forschung Process for Continuous Production of Formed Coke, *Glückauf*, **103** (25), 1967] involves devolatilization of low-rank coal to yield a hot char. The hot char is mixed with a fluid coking coal (about 70 percent char and 30 percent coking coal) which becomes plastic at the mixing temperature, and the mixture is briquetted hot in roll presses to produce "green" briquettes containing 7 to 8 percent volatile matter. If required, further devolatilization of the briquettes is accomplished in a vertical hot-sand carbonizer. The **Ancit process** (Goosens and Hermann, "The Production of Blast Furnace Fuel by the Hot Briquetting Process of Eschweiler Bergwerks-Verein," ECEC, Rome, Mar. 1973). The process is similar to the B-F process in that it uses about 70 percent noncoking coal with about 30 percent coking coal as binder. The noncoking coal component is conveyed pneumatically from bunkers and introduced at two locations into a horizontal, parallel-flight stream reactor heated by hot products of combustion. The coal is heated to 600°C in a fraction of a second and is thermally decomposed by the rapid evolution of water and volatile matter. Coal and gas are separated in a cyclone with the gas passing to a second reactor (installed in tandem arrangement) into which the coking coal is fed. Coal and gas pass to a second cyclone for separation. The two heated coals are fed by screw feeders into a vertical cylindrical mixer, and the mixture is fed to roll presses and briquetted. The **Consolidation Coal process** employs a heated rotary kiln to produce medium-temperature coke pellets from a mixture of char and coking coal. Pellets are then subjected to final high-temperature carbonization in a vertical-shaft unit. Other processes receiving attention were the Sumitomo process, Japan; Auscoke (BHP), Australia; the Sapozhnikov process, Russia; and INIEX, Belgium. After years of work on these various processes, it became apparent that production rates, costs, and product quality could not compete with conventional by-product coke ovens and the test facilities in the United States were shut down.

GASIFICATION

Producer gas and carbureted water gas were common in Europe and the United States for many years and were based on coal and coke. These units gasified the solid fuels by the reaction of oxygen (as air or enriched oxygen) and steam. Oil injection was practiced to improve the heating value. With the widespread distribution of natural gas, these plants have all been closed.

Gasification is achieved by partial oxidation of carbon to CO (exothermic reaction). To obtain a mixture of CO and H₂, water is introduced, typically as steam, which reacts endothermically with the coal. The partial oxidation supplies heat to the endotherm. These reactions are described in detail in Elliott, "Chemistry of Coal Utilization" (2d suppl. vol., Wiley-Interscience). The heating values of the producer gas were approximately 120 Btu/SCF (1,068 kcal/m³) for air-blow units, 250 Btu/SCF (2,225 kcal/m³) or more for oxygen-blown units, and as much as 500 Btu/SCF (4,450 kcal/m³) for the oil-carbureted units. The development of abundant natural-gas supplies and their distribution to most areas of the world have supplanted these processes. In 1974, an oil supply crisis combined with a distribution pinch on natural gas. Interest in converting coal to gaseous and oil fuels was rekindled in the United States. Many processes were piloted by government and industry. These included **Hi-Gas**, **Bi-Gas**, **CO₂ Acceptor**, **Synthane**, **Atgas**, and **molten salt processes**. A demonstration program was established by the U.S. government as the Synthetic Fuels Corporation. The program funded commercial-size units for **Cogas** and **Slagging Lurgi** for synthetic natural gas (SNG), and **H-coal** and **solvent-refined coal** (SRC) for liquids. As natural-gas distribution and the oil supplies improved, the urgency diminished,

and the projects were canceled during the latter part of their design. A notable exception is the commercial-scale **Lurgi** plant, which was built as the Great Plains Project in North Dakota and funded by the Department of Energy to produce SNG. Dakota Gasification Inc. operates this plant and is planning ammonia production due to low natural-gas pricing.

Interest in gasification continued for chemicals manufacture, and power, for several reasons. With respect to power, environmental regulations could be met more readily for sulfur emissions by treating a smaller stream than the corresponding flue gas from a fossil-fueled plant, while yielding a saleable product as opposed to landfill material. The potential efficiency improvement in **combined cycles** with gas turbines and steam turbines would further reduce the size of the treated streams, because of the need for less fuel. Corollary benefits ensue in reducing CO₂ emissions, and allow the use of high-sulfur coals. This has led to the construction of several **integrated gasification combined cycle** (IGCC) plants for power.

As part of this continuity of interest, research on hot gas desulfurization is in progress to reduce thermal losses in gas cooling. Other approaches such as the demonstration of **underground gasification** are being pursued.

Gasifiers come in three types:

1. Fixed-bed with the coal supported by a rotating grate
2. Fluidized-bed, in which the fuel is supported by gaseous reactants
3. Entrained flow gasifiers that use very fine particles suspended in a high-velocity gas stream

Fixed-Bed Gasifiers Representative units are **Lurgi**, **Wellman-Galusha**, **Koppers-Kerpley**, **Heurtey**, and **Woodall Duckham**. Early units were air-blown and used coke, with a number built for anthracite. Agitators were added to permit feeding of bituminous coal. Coal feed is a sized lump, with 1½ in (37 mm) being typical. Fines are tolerated only in small amounts. Early units operated at essentially atmospheric pressure, but later units operate at elevated pressure. Temperatures are limited to avoid softening and clinking of the ash. With air, gas having heating values of 120 to 150 Btu/SCF (1,068 to 1,335 kcal/m³) was produced. Use of oxygen allowed gas heating values of 250 to 300 Btu/SCF (2,225 to 2,673 kcal/m³). Coal is fed through lock hoppers to prevent loss of gases and to permit charging into pressurized units. The gasifiers have a distinct upper reduction zone, which dries and preheats the coal. The gasification reactions take place at 1,150 to 1,600°F (620 to 870°C), and the gases leave the unit at 700 to 1,100°F (370 to 595°C). Under these conditions, methane and other light hydrocarbons, naphtha, phenols, tars, oils, and ammonia are generated. The CH₄ is an advantage in SNG production. Tars and oils are removed from the gas stream before further processing to absorb ammonia and acid gases, including carbon dioxide and hydrogen sulfide.

The devolatilized coal passes into the lower combustion zone, reaching temperatures of 1,800 to 2,500°F (980 to 1,370°C), depending on the ash softening temperatures. It is removed by a rotating grate through lock hoppers.

The **Lurgi process** advanced this concept of a pressurized, oxygen-blown system. Gasifier pressure is 350 to 450 psig (24 to 31 bar). Typical composition of gas from the gasifier with oxygen blowing is as follows:

	Vol % dry basis
C ₂ H ₄	0.42
C ₂ H ₆	0.62
CH ₄	11.38
CO	20.24
H ₂	37.89
N ₂ + A	0.33
CO ₂	28.69
H ₂ S + COS	0.49

After removal of the acid gases (CO₂, H₂S, COS), the gas can be used as fuel gas or can be upgraded to SNG by using the CO shift reaction to adjust the H₂/CO ratio for methanation. This can also be shifted to ratios

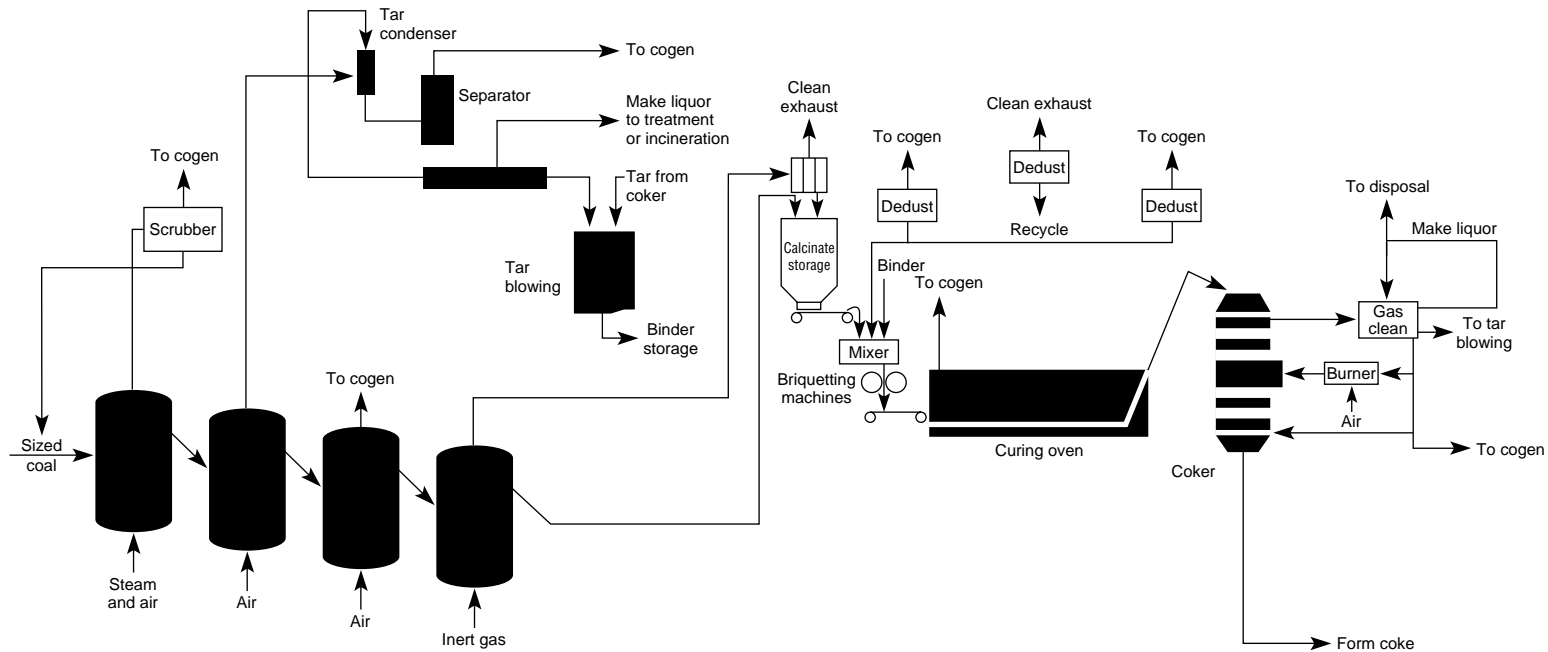

Fig. 7.2.3 FMC form coke flow diagram. (FMC Corp.)

suiting to the synthesis of methanol, or ammonia if H_2 is suitably optimized. A flow diagram of the process is shown in Fig. 7.2.4. This process has been used in a number of commercial plants (Rudolph, *Oil & Gas Jour.* Jan. 22, 1973) including one at Sasolburg in South Africa and one in North Dakota.

A later development is the **British Gas/Lurgi slagging gasifier**. Coal is fed with a size distribution of 2 in by 0 with up to 35 percent minus $\frac{1}{4}$ in. The operation is similar to the dry bottom unit except that molten slag is removed through a slag tap, is water-quenched, and is discharged through a lock hopper. Tars, oils, and naphtha can be recycled to the gasifier. Gas composition differs from the conventional dry ash unit in that water vapor, CO_2 , and CH_4 are lower, and CO is higher, resulting in cold gas efficiencies of 88 percent or more. The unit was tested extensively on a variety of coals including caking types at the British Gas Town Gas Plant in Westfield, Scotland. This was to have been one of the demonstration plants of the Synfuels Corp. (Lurgi Corp., private communication).

Fluid-Bed Gasifiers The Winkler and Kellogg KRW (formerly Westinghouse) gasifiers constitute this design. Since the bed is truly fluidized, it permits the flexibility of processing solids such as coal and coke. Particle sizes of $\frac{1}{8}$ to $\frac{3}{8}$ in (3 to 10 mm) are required. Lock hoppers are the method of coal feed. The **Winkler process** employs the fluidized-bed technique, and it has been commercialized in a number of plants (Banchik, "Clean Fuels from Coal," IGT symposium, Chicago, Sept. 1973). Caking coals may be preoxidized to avoid agglomeration. The mixing of the bed causes a uniform temperature, so that the distinct regions of oxidation and reduction of the fixed-bed units are absent. To avoid agglomeration by softening of the ash and loss of fluidization, temperatures are limited to 1,800 to 2,000°F (980 to 1,095°C). Because of the relatively low temperature, these units are primarily useful with reactive coals such as lignite and subbituminous. It has been further developed in a pressure mode as the **high-temperature Winkler (HTW) process** by Rheinbraun, Uhde, and Lurgi. This process is being used for a 300-MW ICGG plant at 25 bar (362 lb/in²) and is scheduled for start-up in 1995. (Adloch et al., The Development of the HTW Coal Gasification Process, Rheinbraun, Uhde, Lurgi brochure.)

The **Kellogg gasifier** is an extension of the design developed by **Westinghouse**, which used limestone or dolomite to capture sulfur in the bed, similar to fluid-bed combustion. The gasifier is shown in Fig. 7.2.5. The coal is quickly pyrolyzed in the jet, which supplies the endothermic heat for reaction. This permits a high proportion of fines to be used. The agitation of this region and the rapid approach to high temperature permit the use of highly caking coals. Operating conditions are 1,900 to 2,000°F (1,040 to 1,050°C), at pressures to 300 psig (21 bar). Further, the combination of retention time and temperature cracks tars and oils to CH_4 , CO , and H_2 . Product gas is removed through cyclones, where carbon dust and ash are collected and recycled to the gasifier. The gas has a residual concentration of H_2S and COS so that desulfurization may be required. Regenerable **hot-gas desulfurization (HGD) systems**, with zinc reagents, have been developed which recover the sulfur as SO_2 . The gas is further cleaned by removing residual fines by ceramic filter candles. The gases then go to gas turbines in a combined cycle.

The residual solids contain carbon, sulfided sorbent, and ash. With the alkaline components, the mixture forms eutectics with melting points of 1,000 to 2,000°F (540 to 1,090°C). In the zone between the combustion jet and the fluid bed, the smaller particles tend to agglomerate, and fall, while char particles rise into the reaction zone. The solids, called **lash**, contain sulfided components which are converted to sulfates after leaving the gasifier in a sulfator/combustor.

This design has been selected by the Sierra Pacific Power Company for commercial demonstration as a 100-MW IGCC plant at the Piñon Pine Station near Reno, Nevada. In addition, further development of the process is proceeding with a transport gasifier, based on petroleum fluid catalytic cracking technology. The particle size in this unit is smaller than that in the fluid bed, improving reaction kinetics and allowing shorter residence times. Limestone is used as the sulfur sorbent. This technique is also being applied to the **hot-gas desulfurizer (HGD)** to incorporate the regeneration of zinc sorbent on a continuous basis. The **transport HGD** is incorporated into the Sierra Pacific project. The transport gasifier concept is under test operation at Southern Company Services, in Wilsonville, Alabama, under a cooperative agreement with the Department of Energy. (Campbell, "Kellogg's KRW Fluid Bed Process

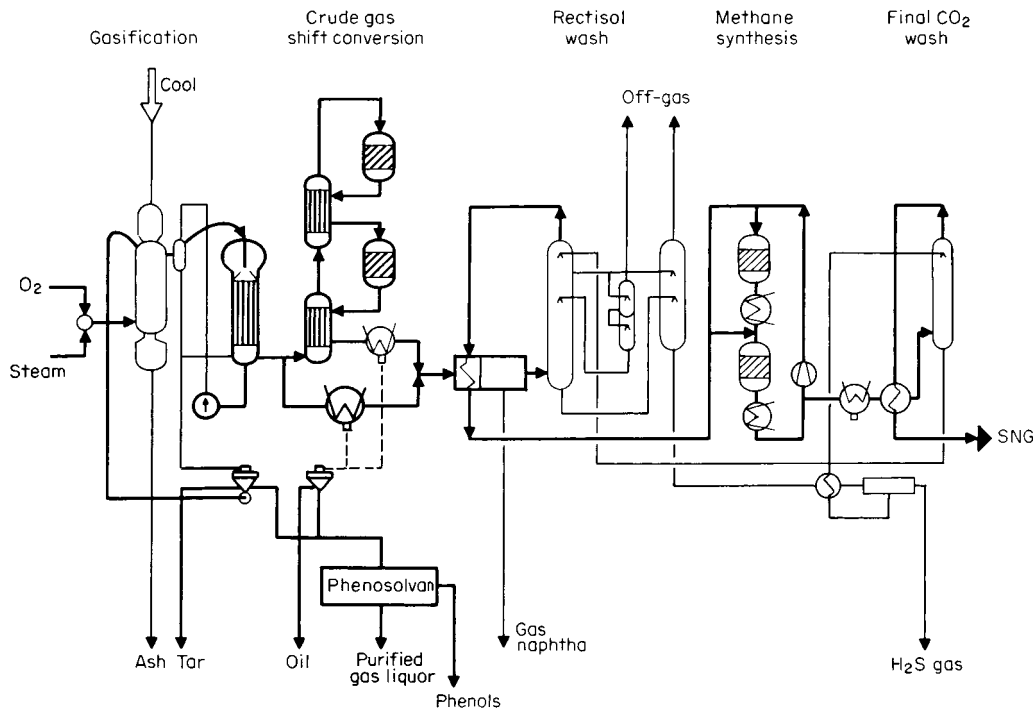

Fig. 7.2.4 Lurgi process.

for Gasification of Petroleum Coke," The M. W. Kellogg Co., December 1994.)

Entrained Flow Gasifiers These have been developed as coal gasifiers, and as partial oxidation units to produce synthesis gas from liquid hydrocarbons, petroleum residues, or coke. They are characterized by a

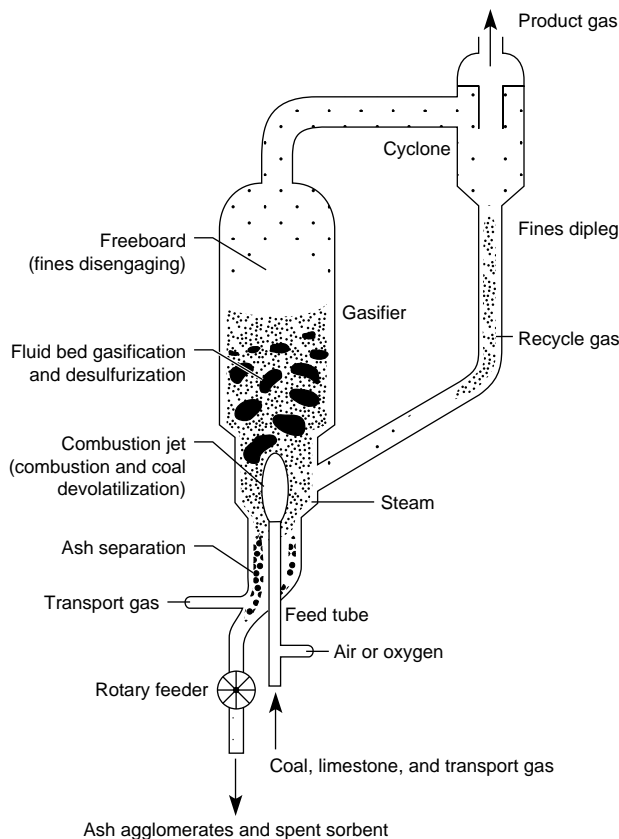

Fig. 7.2.5 KRW fluid-bed gasifier. (M. W. Kellogg Co.)

short residence time (< 1 s) and concurrent flow of the feed and gasifying agents. Operating temperatures are high, from 2,200 to 3,500°F (1,200 to 1,927°C) and pressures are as high as 80 bar (1,200 psig). Coal feed systems may be dry with lock hoppers and pneumatic transport, or water slurries of coal. Thus, any feedstock which can be pulverized and dispersed can be processed, including highly caking coals. Oxygen is used as the oxidant reactant to achieve the high temperatures required. This has the additional advantage of not diluting the product gas with nitrogen, particularly if the gas is for synthesis. Product gases are free of tars, condensable hydrocarbons, phenols, and ammonia. Sulfur compounds such as H₂S and COS must be scrubbed from the gas. The high temperature results in slagging operation of these units. Commercial processes include **Texaco**, **Shell**, and **Destec**. All operate at elevated pressure. The **Koppers-Totzek** was an atmospheric unit, but it has been developed into a pressurized system, now the **PRENFLO gasifier**.

The **Texaco gasification process (TGP)** is the application of the Texaco partial oxidation process to the use of a slurry feed of coal (60 to 70 wt %) in water. The unit is operated at temperatures of 1,200 to 1,500°C (2,200 to 2,700°F) at pressures of 27 to 80 bar (400 to 1,200 psig). The slurry is fed with oxygen through a special injection nozzle into the refractory-lined gasifier to produce syngas, while slagging the ash. The syngas goes to a water-quenched unit or a waste heat boiler. The latter is typical for an IGCC facility. Fine ash is removed by a scrubber before conventional removal of H₂S. The molten ash or slag exits the gasifier, is water-quenched, and is removed through lock hoppers for disposal. The slag forms a glassy solid which is nonhazardous. Typical gasifier products are shown in Table 7.2.5. The cleaned gas is used for gas-turbine fuel or for chemicals manufacture. The plant configuration can be modified for optimal heat recovery for a power cycle or for maximum H₂ and CO generation for **chemical production**. A configuration for **power application** is shown in Fig. 7.2.6. The process was demonstrated at a commercial-size (110-MW) combined-cycle (IGCC) unit at the Coolwater project, which tested many coals during its operation from 1984 to 1989. Emissions of SO₂ from the Coolwater demonstration plant were as low as 0.076 lb/TBtu (0.033 kgs/10⁶ kJ) and of NO_x of 0.07 lb/TBtu (0.03 kg/10⁶ kJ). Under the Clean Coal Program of DOE, a facility to provide 260 MW at Tampa Electric Co. Polk Station is under construction, to be in operation in early 1996, with projected heat rates below 8,500 Btu/kWh (8,960 kJ/kWh). The process has been selected for power projects from 250 to 600 MW worldwide and for several chemical plants, particularly in the People's Republic of China. Eastman Chemical Co. has employed TGP for over 12

Table 7.2.5 Syngas Production from Various Carbonaceous Feeds (Texaco)

Feed type:	Coal					Petroleum Coke		Coal Liquef. Residue	
	Pittsb. no. 8	French	Utah	German	S. African	Delayed	Fluid	Molten	Slurry
Feedstock dry anal., wt. %									
Carbon	74.16	78.08	68.21	73.93	65.60	88.50	85.98	68.39	68.39
Hydrogen	5.15	5.26	4.78	4.65	3.51	3.90	2.00	4.75	4.75
Nitrogen	1.18	0.85	1.22	1.50	1.53	1.50	0.98	0.98	0.98
Sulfur	3.27	0.47	0.37	1.08	0.87	5.50	8.31	1.87	1.87
Oxygen	6.70	8.23	15.69	5.85	7.79	0.10	2.27	2.21	2.21
Ash	9.54	7.11	9.73	13.01	20.70	0.50	0.46	21.80	21.80
Higher heating value									
Btu/lb	13,600	14,000	11,800	13,200	11,200	15,400	13,800	12,700	12,700
kcal/kg	7,540	7,780	6,570	7,330	6,220	8,550	7,665	7,060	7,060
Product composition mol %									
Carbon monoxide	39.95	37.36	30.88	39.46	36.53	46.20	47.14	46.31	33.48
Hydrogen	30.78	29.26	26.71	29.33	26.01	28.69	24.33	35.54	28.56
Carbon dioxide	11.43	13.30	15.91	12.59	15.67	10.68	13.16	6.41	13.09
Water	16.43	19.43	25.67	17.47	20.82	12.37	12.67	10.46	23.72
Methane	0.04	0.16	0.22	0.25	0.02	0.17	0.09	0.27	0.23
Nitrogen and argon	0.49	0.37	0.50	0.60	0.68	0.55	0.42	0.45	0.42
Hydrogen sulfide + carbonyl sulfide	0.88	0.12	0.11	0.30	0.27	1.34	2.19	0.56	0.50

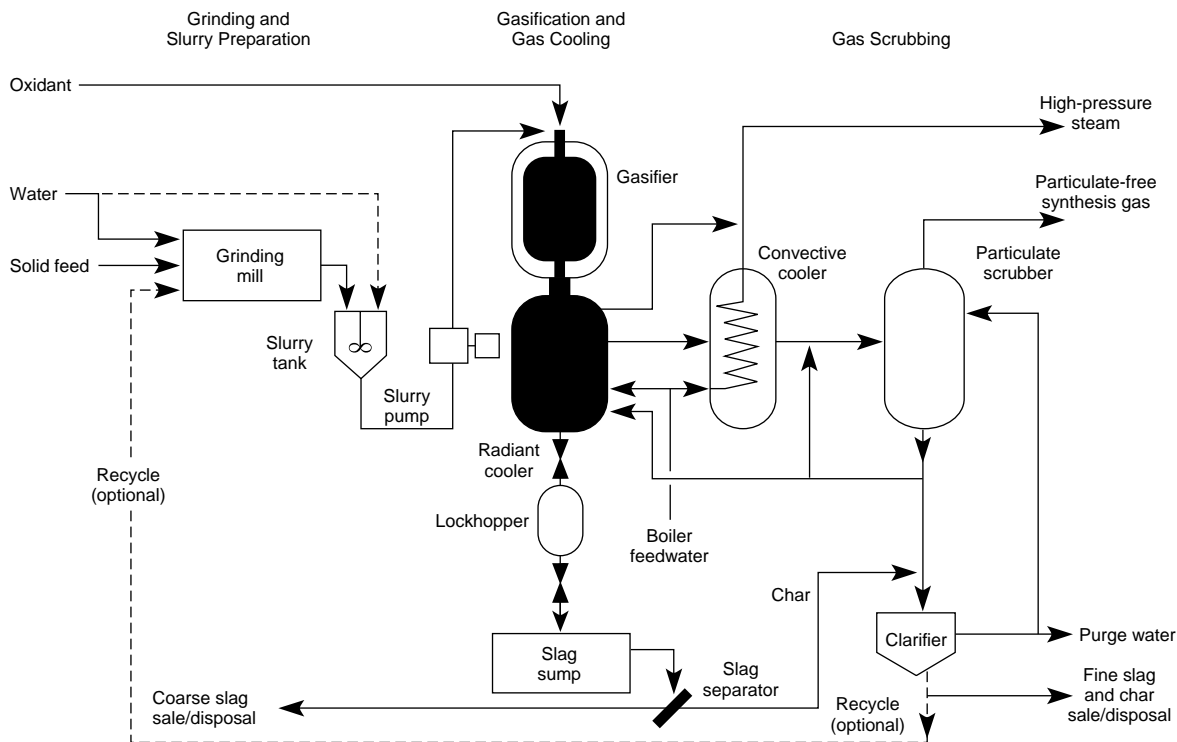

Fig. 7.2.6 TGP-Gas cooler mode. (Texaco Development Corp.)

years, using 1,150 tons/d of coal to make acetic anhydride for photographic films and chemicals. Ube Industries produces 1,000 Mt/d of ammonia in Japan. (Gerstbrein and Guenther, International VGB Conference, Dortmund, May 1991; Janke, American Power Conference, Chicago, Apr. 1995; Texaco Gasification Process for Solid Feedstocks, *Texaco Dev't Corp. Bull. Z-2154*, 1993; Watts, 6th Annual International Coal Conference, Pittsburgh, Sept. 1989.)

Variations in the configuration of other gasifiers are made to improve thermal efficiency. An example is the **Destec** unit, which has two stages. The coal slurry is fed to both stages, that going to the first providing the exothermic heat by partial oxidation by the oxidant. This is absorbed later, in the second stage, by the endothermic gasification of the coal, without oxidant. Operating conditions of the first stage are 1,450°C (2,600°F) at 27 bar (400 psig), the exit gas being about 1,040°C (1,900°F). The syngas from the gasifier is cooled, generating high-pressure steam used in steam turbines. Particulates are removed, and the gas is scrubbed to remove H₂S before it is being fed to the gas turbine-generator sets. The **Destec** gasifier is illustrated in Fig. 7.2.7. The system has been operating in a 160-MW facility at Dow Chemical, Plaquemine, LA, since 1987. The Destec technology is being used at the PSI Energy Inc. Wabash River plant to combine a 100-MW steam-turbine facility with a gas turbine to yield 262 MW. The net plant heat rate of this unit is 9,000 Btu/kWh (9,500 kJ/kWh), compared to typical values of 10,500 Btu/kWh (11,077 kJ/kWh) for a new coal-fired plant with SO₂ scrubbers. (Destec Energy, Inc., *Tecnotes* nos. 8 and 14, personal communication.)

New Developments The research in coal conversion has been limited by available resources, i.e., an abundant oil and gas supply. One effort which has continued involves is **underground coal gasification** (UGC), wherein the coal seam is both reactor and reactant in place. It has been practiced in Russia for some time for local industrial and residential heating. During the oil crisis of the 1970s, this research program was supported by the U.S. Department of Energy and a consortium of industrial companies. The technology depends on the evalu-

ation of several characteristics: coal seam characteristics such as dip, thickness, partings and rock lenses; coal chemistry; its agglomerating and free-swelling properties; water, ash, and sulfur content; boundary strata; overburden height; faults; bulking factor; and hydrology. The program was begun in Wyoming with a series of test burns, which continue under private auspices. Design is underway in New Zealand for an IGCC based on test burns of their coal seams. (Energy International Corp, private communication.)

Gasification of Liquid Hydrocarbons In the era of manufactured gas in the United States, both base-load and peak-shaving gases were produced by gasifying oils via thermal cracking techniques. Most of the processes produced gases having calorific values compatible with coal gas (coke-oven gas). As natural gas became available, some processes were modified to produce a high-heating-value gas interchangeable with natural gas. These oil-gas units operated on a cyclic (heat-make) basis. To supply the heat for the endothermic thermal cracking of oil, a mass of checker brick was heated to 1,300 to 1,700°F (705 to 925°C) by burning oil and deposited carbon with air. During the "make" cycle, steam and oil were introduced to produce a mixture of hydrogen, methane, saturated and unsaturated hydrocarbons, aromatic oils, tar, and carbon.

The supply of natural gas throughout the world displaced the manufactured gas plants by virtue of lower cost, operational simplicity, and the reduction of emissions. Some manufactured gas and coke-oven gas were distributed into the early 1980s, but this is no longer current practice.

Increased demand for chemicals resulted in the development of processes for production of carbon monoxide, hydrogen, and carbon dioxide. These are for the chemical synthesis of ammonia and methanol, which are feedstocks for many other products. The processes include **partial oxidation, catalytic reforming, and hydrogasification**

Partial oxidation processes were developed to produce syngas from liquid feedstocks of any weight, particularly heavy residual oils. These processes produce principally a carbon-monoxide-rich gas which is

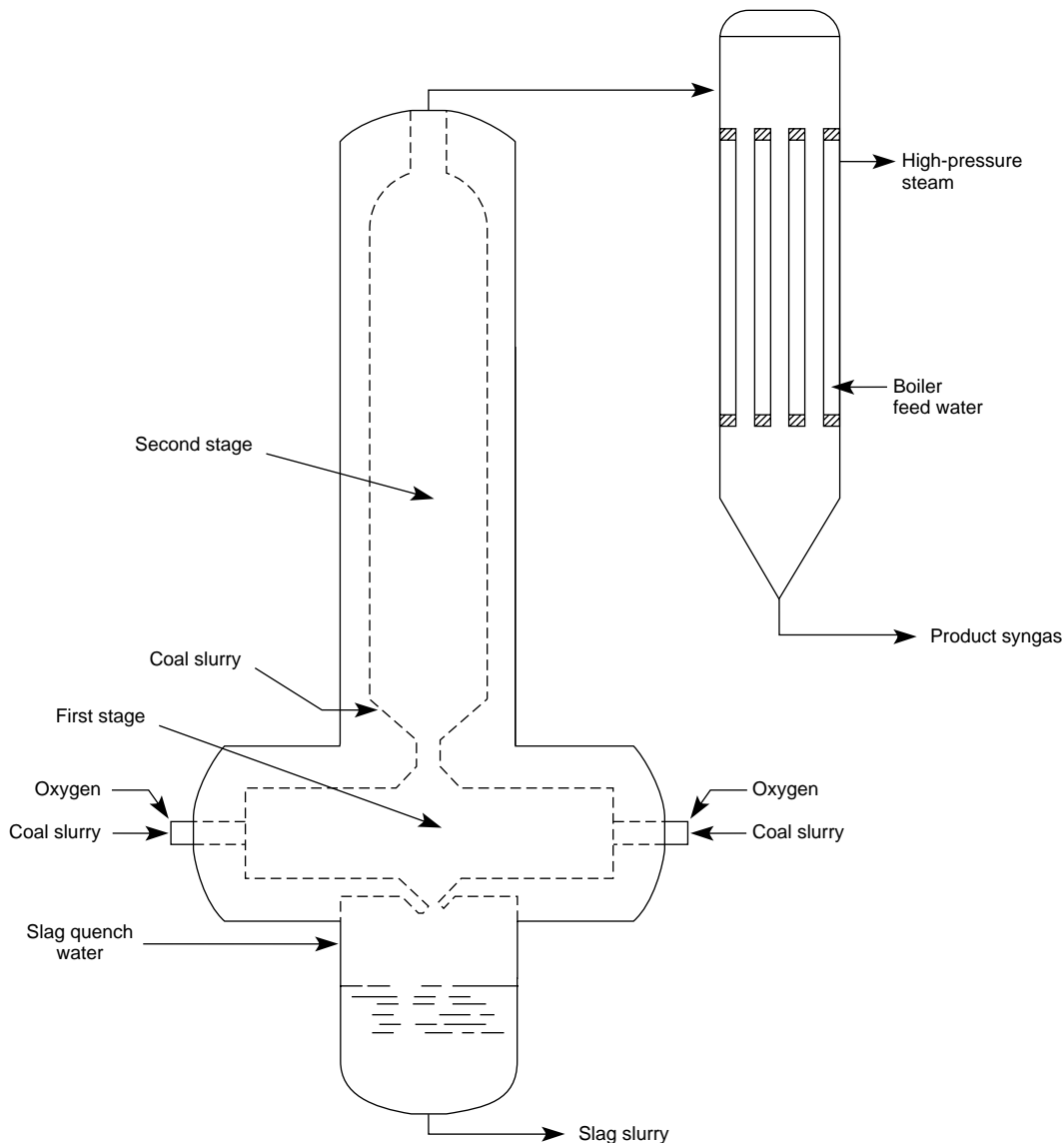

Fig. 7.2.7 Dow two-stage gasifier. (Destec Energy, Inc.)

reacted with water in a shift reactor to add hydrogen. Catalytic systems then produce methane or other chemicals. **Texaco** and **Shell** developed their processes originally for these reasons and later adapted them to coal gasification.

Catalytic reforming of naphtha, natural-gas liquids, and LPG is presently applied commercially for the production of synthetic natural gas. Over 30 plants with a total capacity of 6.5×10^9 SCF/d (184 million m^3/d) are planned, but the actual number of installations is limited by availability of feedstock. Commercial processes available are the **CRG** (**catalytic-rich gas**), British Gas Council; **MRG** (**methane-rich gas**), Japan Gasoline Co.; and **Gasynthan**, BASF/Lurgi. Processes are similar in that each uses steam reforming of light hydrocarbons over a bed of nickel catalyst. The product gas is a mixture of methane, carbon monoxide, carbon dioxide, and hydrogen. Upgrading to synthetic natural gas requires methanation steps. The four basic steps of the process are desulfurization, gasification, methanation, and purification (CO_2 removal and drying).

Hydrogasification The British Gas Corporation has developed the **GRH** (**gas recycle hydrogenator**) for hydrogenating vaporizable oils to produce synthetic natural gas, and the **FHB** (**fluid-bed hydrogenation**) of gasifying crudes or heavy oils for synthetic natural-gas production. In the **GRH process**, naphthas, middle distillates, and gas oils that need not be desulfurized are reacted directly with hydrogen-rich gas prepared by steam reforming a rich gas sidestream. Exothermic reactions decompose paraffins and naphthenes into methane and ethane. In the **FBH process**, crude or heavy oil is preheated and atomized in the presence of coke particles fluidized by a supply of preheated hydrogen-rich gas. Paraffins and naphthenes are hydrogenated to methane and ethane, and an aromatic condensate is recovered. Desulfurization, followed by secondary hydrogenation, allows reduction of hydrogen and ethane to produce synthetic natural gas.

7.3 COMBUSTION FURNACES

by Glenn W. Baggley

REFERENCE: Trinks-Mawhinney, "Industrial Furnaces," vols. 1 and 2, Wiley.

FUELS

The selection of the best fuel should be based upon a study of the comparative prepared costs, cleanliness of operation, adaptability to temperature control, labor required, and the effects of each fuel upon the material to be heated and upon the furnace lining. Attention must be paid to the quantity to be burned in each burner, the atmosphere (fuel/air ratio) desired in the furnace, and the uniformity of temperature distribution required, which determines the number and the location of the burners. Common methods of burning furnace fuels are as follows:

Solid Fuels (Almost Entirely Bituminous Coals)

Coal was once a common fuel for industrial furnaces, either hand-fired, stoker-fired, or with powdered coal burners. With the increasing necessity for accurate control of temperature and atmosphere in industrial heating, coal has been almost entirely replaced by liquid and gaseous fuels. It can be expected that methods will be developed for the production of a synthetic gas (natural-gas equivalent) from coal.

Liquid Fuels (Fuel Oil and Tar)

To burn liquid fuels effectively, first it is necessary to atomize the oil into tiny droplets which then vaporize and burn. Atomization can be accomplished mechanically or with the aid of steam or air. With heavy oils and tar, it is important to maintain the proper viscosity of the oil at the atomizer by preheating the fuel.

For larger industrial burners, combustion air is supplied by fans of appropriate capacity and pressure. Combustion air is induced with some smaller burner designs.

Gaseous Fuels

Burners for refined gases (natural gas, synthetic gas, coke-oven gas, clean producer gas, propane, butane):

Two-pipe systems: Include blast burners (open or closed setting), nozzle mixing, luminous flame, excess air (tempered flame), baffle, and radiant-tube burners, all for low-pressure gas and air.

Premix systems: Air and gas mixed in a blower and supplied through one pipe.

Proportioning low-pressure mixers: Air and gas supplied under pressure and proportioned automatically (air aspirating gas or gas inspirating air). The resulting mixture is burned in tunnel burners, radiant-cup, baffle, radiant-tube, ribbon, and line burners.

Pilot flames are generally used to ensure ignition for gas and oil burners. Insurance frequently requires additional safety provision in two main categories: an interconnected pressure system to prevent lighting if any burner in a zone is open, and burner monitors using heat or light to permit ignition.

Burners for crude gas (raw producer-gas, blast-furnace gas, or coke-oven gas):

Simple mixing systems with large orifices and simple mechanisms which cannot become clogged by tar and dirt contained in these gases.

Separate gas and air supplies to the furnace, with all mixture taking place within the furnace.

TYPES OF INDUSTRIAL HEATING FURNACES

Heating furnaces are usually classified according to (1) the purpose for which the material is heated, (2) the nature of the transfer of heat to the material, (3) the method of firing the furnace, or (4) the method of handling material through the furnace.

Purpose Primarily a metallurgical distinction, according as the furnace is intended for tempering, annealing, carburizing, cyaniding, case hardening, forging, heating for forming or rolling, enameling, or for some other purpose.

Transfer of Heat The principal varieties are **oven furnaces**, in which the heat is transferred from the products of combustion of the fuel, in direct contact with the heated material, by convection and direct radiation from the hot gases or by reradiation from the hot walls of the furnace; **muffle furnaces**, in which the heat is conducted through a metal or refractory muffle which protects the heated material from contact with the gases, and is then transferred from the interior of the muffle by radiation to the heated material, which is sometimes surrounded by inert gases to exclude air; or **liquid-bath furnaces**, in which a metal pot is heated on the outside or by immersion. This pot contains a liquid heating or processing medium which transfers heat to the material contained in it. This type includes low-temperature tempering furnaces with oil as the heating medium, hardening furnaces using a bath of lead, hardening and cyaniding furnaces with baths of special salts, and galvanizing or tinning furnaces for coating the heating material with zinc or tin. The generally accepted form of muffle is the **radiant-tube** fired furnace, in which the fuel is burned in metal or refractory tubes which radiate heat to the charge. An important form of furnace for temperatures below 1,300°F (700°C) is the **recirculating** type, in which the atmosphere (products of combustion, air, or protective gases) is recirculated rapidly through the heating chamber. **Forced convection** heating is accomplished by a large number of jets of hot gas at high velocity. In **high-speed** heating (or **patterned combustion**), premixed burners are arranged for close application of heat, and with a high-temperature head, very rapid heating is achieved.

Method of Firing This classification applies principally to the oven type of furnace, and it indicates whether the furnace is direct-fired, overfired, underfired, or heated by radiant tubes. Figure 7.3.1 shows the principles of each of these types. The **direct-fired** method finds increased utilization from constant improvement in the design and control of gas and oil burners, especially for temperatures above 1,200°F (650°C). In

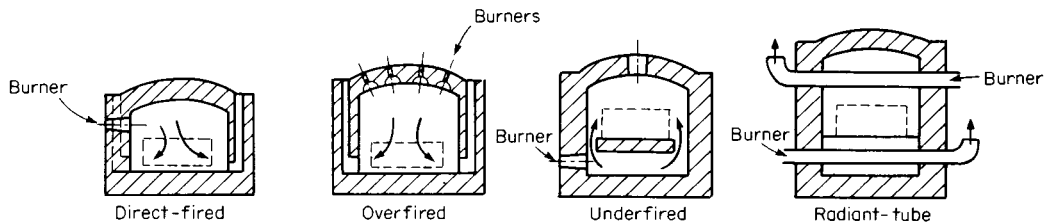

Fig. 7.3.1 Methods of firing oven furnaces.

overfired furnaces, radiant burners fire through the roof and are arranged in patterns to obtain the best temperature distribution. The **underfired** furnace is excellent for temperatures between 800 and 1,800°F (ca. 400 to 1,000°C) because the heated product is protected from the burning fuel. The temperature and atmosphere can be closely controlled, but the temperature is limited by the life of the refractories to about 1,800°F (1,000°C). Many furnaces are now designed for the use of special protective atmospheres and involve the use of **radiant tubes** to avoid any contact with the combustion gases. These fuel-fired tubes of heat-resisting alloy may be horizontal across the furnace above and below the heated material or may be vertical on the sidewalls of the furnace.

Method of Material Handling In the **batch** type, the heated material charged into the furnace remains in the same position until it is withdrawn after sufficient heating. In a **continuous furnace**, the material is moved through the furnace by mechanical means which include pushers, chain conveyors, reciprocating hearths, rotating circular hearths, cars, walking beams, and roller hearths. Continuous furnaces are principally labor-saving devices and may or may not save fuel.

SIZE AND ECONOMY OF FURNACES

The size of furnace required depends upon the amount of material to be heated per hour, the heating time required, the size of the pieces to be heated, and the amount of heat that can be liberated without excessive damage to the furnace. The efficiency and refractory life obtained depend upon the correctness of furnace size.

Heating Time For the usual relation of refractory area to stock area, time to heat steel plate from one side for each 1/8 in (3.18 mm) of thickness varies from 3 min for high-speed heating and 6 to 12 min for heating for forming by usual methods to 20 min for heat treating. Steel cylinders will be heated in one-half these times per 1/8-in (3.18-mm) diam. Below 800°F (ca. 400°C), the time may be 2 to 3 times these values. Brass requires about one-half as long as steel to heat, copper 40 percent as long, and aluminum 85 percent as long. The preceding heating times are based on a furnace temperature 50 to 100°F (ca. 25 to 50°C) higher than the final temperature of the heated material. It is assumed that the material is fully exposed to the heat of the furnace. Piling of material in a furnace lengthens the heating time by an amount that must be determined by actual trial. In addition to simple heating, there is frequently additional **time required for soaking** (holding at furnace temperature) to cause metallurgical changes in the material or for some other reason.

The **weight of material in the furnace** at any time is the product of weight of material per hour multiplied by the heating time in hours. If the weight and sizes of pieces involved are known, the **area of the furnace** can then be fixed. The width and length of the furnace to produce this hearth are fixed by the method of firing to be used and by the method of handling material.

The life of a furnace at given temperature depends upon the rate of heating, which may be expressed in pounds per square foot of hearth area per hour. The maximum allowable **rate of heating steel** is about 35 lb/(ft² · h) for heat treating, 70 lb for in-and-out rolling-mill furnaces, 100 lb for single-zone continuous furnaces, and 150 lb for multiple-zone furnaces. These are upper limits which should not be used if long life of furnace refractories is expected. These rates are for heating mild steel; they may be about twice as great when heating brass, 2½ times as great for copper, 0.7 as great for alloy steel, and 1.1 times as great when heating aluminum. These maximum allowable rates should be used only for checking the calculation of size, because some shapes and sizes of pieces cannot be properly heated when piled in such a manner as to produce these rates. If the calculated size of the furnace corresponds to a

rate of heating that is too great, it should be reduced by making the furnace larger. If the rate is too small, it can sometimes be increased by piling material in a smaller furnace.

EXAMPLE. To determine furnace size. If a furnace is required to heat 20 pieces per h weighing 30 lb each and requiring a heating time of 1/2 h, the furnace must be large enough to hold 1/2 × 20 = 10 pieces. If each piece requires an area of 2 ft², the area of the hearth will be 2 × 10 = 20 ft² for a single layer of pieces in the furnace. If the furnace is of the batch type, a size of 4 ft wide × 5 ft deep would probably be about right for convenient handling. On checking, the rate of heating is 20 pieces per h × 30 lb/20 ft² = 30 lb/(ft² · h). For this rate an underfired furnace would be satisfactory, although for other methods of firing, a smaller furnace could be used if the pieces could be more densely piled without seriously interfering with the circulation in the furnace.

The heat released by the fuel in a furnace (heat input) is equal to the sum of the heat required in the heating process (useful heat) plus the heat losses from the furnace. **Heat input** includes the heat of combustion of the fuel, sensible heat in preheated air or fuel, and heat in the material charged. Low-heat values of the fuel are used, and the sensible heat can be calculated from the specific heats of the preheated air, fuel, or material. **Useful heat** includes the heat absorbed by the material in the furnace. Figure 7.3.2 gives heat contents for different metals. In the simple heating of metals, the useful heat applied to the metal includes only the heat absorption, as given in Fig. 7.3.2; but there are many processes that include other requirements, such as drying, where moisture must be heated and evaporated, heating of chemical products where heat is utilized to cause chemical changes, and other special cases. (See also Sec. 4.3.)

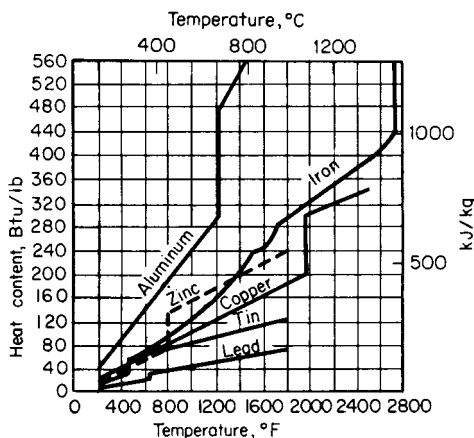

Fig. 7.3.2 Heat content of metals.

Heat losses in a heating furnace include heat lost in waste gases, radiation from and heat absorbed by refractories, heat carried out of the furnace by containers or conveyors, heat lost through openings, and heat in unburned fuel escaping with the products of combustion. The **heat contained in waste gases** depends upon the temperature of these gases as they leave the heating chamber. Table 7.3.1 gives the approximate percentage of heat contained in the flue gases from perfect combustion at different temperatures. These values are about the same for most fuels except producer gas and blast-furnace gas, the losses with which are higher than those given in the table.

Radiation and heat absorption by refractories depend also upon the rate of heating (which determines the interior temperature of the refracto-

Table 7.3.1 Average Heat in Waste Products of Combustion at Various Temperatures, Percent of Low Heat Value of the Fuel

Temp of gases, °F	1,000	1,200	1,400	1,600	1,800	2,000	2,200
Temp of gases, °C	540	650	760	870	980	1,090	1,200
% of low heat value in gases	24	28	34	38	45	50	55

Table 7.3.2 Radiation through Openings in Furnace Walls, kBtu/h

Size of opening, in*	Furnace temp, °F (°C)					
	1,400 (760)			2,200 (1,200)		
	Wall thickness, in*			Wall thickness, in*		
	4½	9	18	4½	9	18
4½ × 4½	1.4	1.1	0.8	5.1	4.1	2.8
9 × 9	7.8	6.1	4.5	28.5	22.7	16.8
18 × 18	37	30.5	24.3	137	114	90
24 × 24	71	60	48	264	225	180
36 × 36	173	150	124	650	560	465

* × 25.4 = mm.

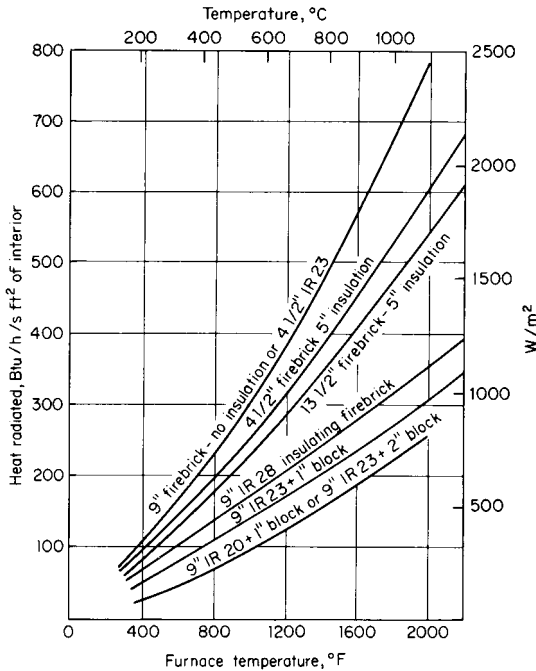

Fig. 7.3.3 Heat loss from thoroughly heated walls, based on interior area.

ries) and upon the refractory area and thickness. Figure 7.3.3 shows the heat radiated through walls of different thickness at various furnace temperatures, for equilibrium conditions, when the wall has reached steady temperatures throughout (see also references at the beginning of this section and Keller, "Flow of Heat through Furnace Hearths," ASME). The heat carried out by containers and conveyors is the sensible heat content of these items as they leave the heating chamber. Such losses include the heat in carburizing boxes, pans, chain conveyors, and furnace cars. Radiation from furnace openings depend upon the size and shape of the opening and the thickness of the walls in which they are located, as well as upon the temperature of the furnace. Some idea of the magnitude of these losses is given by the values in Table 7.3.2.

The heat lost in unburned fuel escaping with the flue gases is small in most furnaces because the fuel can be almost completely consumed.

The efficiency of an industrial furnace is the ratio of the heat absorbed by the heated material to the heat of combustion of the fuel burned.

The magnitude of the various heat losses is indicated in Table 7.3.3.

Table 7.3.3 Heat Balances for Various Furnace Types, Percent of Heat of Combustion

Disposition of heat	Type I	Type II	Type III
Heat to material, or efficiency	16	49	23
Heat to refractories	20	17	22
Heat lost in flue gases	44	19	40
Heat to water cooling	—	5	—
Heat through openings	20	10	15

Column I is for a high-temperature batch-type billet-heating furnace, heating 4,200 lb of billets, per hour, a furnace load at a time, to 2,300°F,

Table 7.3.4 Average Net Efficiencies and Fuel Requirements of Various Furnace Types with Good Operation

Type	Temp, °F	Temp, °C	Avg efficiency, %	Avg heat required from fuel, Btu/lb,* of steel
Ingot heating, soaking pits, recuperative	2,000–2,400	1,100–1,300	20	500
Billet heating for forming:				
Batch, in-and-out	2,000–2,400	1,100–1,300	20	1,750
Continuous	2,000–2,400	1,100–1,300	32	1,100
Wire annealing of coils, hood type	1,300–1,500	700–800	16	1,350
Wire annealing of strands, in lead	1,300–1,500	700–800	19	1,100
Wire patenting, strands	1,650	900	21	1,250
Wire baking, coils, continuous	450	230	20	250
Tube annealing, continuous, bright	1,300–1,500	700–800	35	600
Skelp heating, butt weld, continuous	2,900	1,600	25	1,500
Slab heating, continuous, recuperative	2,400	1,300	42	800
Strip coil annealing, hood type	1,250–1,400	680–760	30	600
Hardening, continuous conveyor	1,650	900	21	1,250
Drawing, continuous conveyor	900–1,100	500–600	20	750
Carburizing, gas, continuous	1,750	950	19	1,500

* × 2.326 = kJ/kg.

at a rate of 25 lb/(ft² · h), averaged over 10 h of operation, and with a fuel consumption of 30 gal of oil per ton of steel heated. Column II is for a large continuous billet-heating furnace of the usual pusher type with a flow of gases opposite to that of the steel, and operating at a rate of 60 lb of steel heated to 2,300°F/ft² of hearth area per hour. Column III is for an underfired batch-type furnace, heating steel to 1,600°F for annealing, at a rate of 30 lb/(ft³ · h).

Table 7.3.4 gives average requirements in fuel of typical industrial heating furnaces. The values are for furnaces without heat-saving appliances (recuperators, regenerators, or waste-heat boilers) except as noted and show the efficiency and the Btu required in the fuel per net pound of steel heated. To obtain the average amount of any fuel required, this latter figure is divided by the low heat value of the fuel. The values are for average rates of heating. Fuel economy is of small importance as compared with the quality of the product.

FURNACE CONSTRUCTION

When furnace refractories are made up largely of standard bricks and shapes, it is advisable to specify furnace dimensions that can be built with a minimum of cutting. Horizontal flues are made a multiple of 2½ or 3 in (63 or 76 mm) in height, and most other flue dimensions are multiples of 4½ in (114 mm) to correspond to the width and length of standard bricks. The area of furnace flues must be large enough to avoid excessive pressures at maximum fuel rates. Flues should be located so as to promote the circulation of gases in all parts of the furnace. Average allowable **velocities in flues** for furnaces without stacks are:

Furnace temp, °F (°C)	200 (93)	1,000 (538)	1,500 (816)	2,000 (1,093)
Allowable velocity (hot gases), ft/s (m/s)	9 (2.74)	13 (3.97)	15 (4.57)	17 (5.2)

The total **flue areas required** in in²/ft³ of fuel/h (or per gal/h for fuel oil) for furnaces without stacks as temperatures of the products of combustion of 1,000 and 2,000°F are as follows:

Temp, °F (°C)	Fuel oil	Natural gas	Artificial gas	Coke-oven gas	Raw producer gas
1,000 (538)	14.0	0.11	0.06	0.05	0.02
2,000 (1,093)	19.0	0.15	0.08	0.06	0.02

The **metal parts of a furnace**, consist of the steel and cast-iron binding, alloy parts exposed to the direct heat of the furnace, and water-cooled steel members. The alloy parts are of nickel or chromium alloys and must be made heavy enough to offset the loss of strength at high temperatures. They are resistant to oxidation at temperatures below 2,000°F (1,093°C). To reduce heat losses, water-cooled members must be insulated.

HEAT-SAVING METHODS

Methods of conserving heat include the use of recuperators or regenerators, waste-heat boilers (see Sec. 9), insulation of refractories, automatic control of temperature and atmosphere, and special attention to the construction and operation of the furnace.

Recuperators and regenerators extract some heat from the escaping flue gases and return it to the furnace by preheating the combustion air or the entering fuel. In **recuperators**, continuous flow of hot gases and cold entering air or gas is maintained through metal or refractory ducts which keep the two gas streams apart but which conduct heat from the hotter stream to the colder. Recuperators are built in the form of self-enclosed units set above the ground or in pits below floor level, and are made of fire-clay tile, silicon carbide, or heat-resisting metal. Overall coefficients of heat transfer in metallic recuperators are between 2.5 and 6.0 Btu/(ft² · h · °F) [14 and 34 W/(m² · °C)] and in silicon carbide recuperators about the same; the coefficient for fire-clay recuperators is considerably less than these values. Usual velocities of hot air in recuperators do not exceed 12 ft/s (3.6 m/s) in order to keep pressure drop to a reasonable value.

Regenerators are used where the high temperature of air preheat is

required to maintain a high furnace temperature or to obtain high thermal efficiency. When one regenerator serves an entire furnace, it is usually constructed of fire brick and consists of two chambers completely filled with a checkerwork. The flow of flue gases and that of air or gas to be heated are periodically reversed so that the hot gases and cold gases alternately flow through the two sets of chambers. The checkerwork retains the heat of the hot gases and gives it up to the cold gases with each reversal. Another regenerator design employs metal plates. Regenerators are frequently used with glass-melting furnaces and are used almost exclusively where open-hearth furnaces are still employed. Overall coefficient of heat transfer in regenerators is from 1.5 to 2.5 Btu/ft² of checkerbrick surface per h per °F temperature difference ([8.5 to 14 W/(m² · C)], and the usual mass velocity of hot gas through the openings of the checker is about 0.065 lb/(ft² · s) [0.32 kg/(m² · s)].

Each burner may also be equipped with its own regenerator. With this design, burners are installed in pairs. When one burner is firing, the products of combustion pass through the second burner and the attached regenerator. The medium in the regenerator recovers and stores heat from the products of combustion. After one cycle, which typically lasts for 20 to 90 s, the functions of the two burners reverse. The burner that was firing now becomes the flue. Combustion air passes through the regenerator of the other burner and is heated by the medium. Typical medium is high-alumina material in ball or grain form. Air is preheated to a temperature within 300°F of the products of combustion. This type of regenerative burner is typically installed in continuous and batch reheating furnaces and aluminum-melting furnaces.

The **savings effected by recuperators or regenerators** depend upon the flue gas temperature and the temperature to which the incoming air or gas is preheated. With a flue gas temperature of 1,600°F, the theoretical

savings in fuel with 200°F preheat of combustion air is about 4 percent, with 400°F, 11 percent; with 600°F, 15 percent; and with 800°F, 19 percent.

A recuperator or a regenerator installation, to be a good investment, must show a satisfactory net savings after all costs of investment, repairs, and associated shutdown time lost by such repairs are subtracted from the savings in fuel used or investment savings related to the heat recovery system. For example, it is often possible to reduce the length of continuous furnaces using regenerative burners compared to more conventional designs.

Automatic control prevents the waste of heat by unnecessarily high temperatures, preventable cold periods, and excessive air or unburned fuel from poor combustion. Of even greater importance is the prevention of damage to the heated product from overheating, excessive oxidation, and objectionable chemical reaction between furnace atmosphere and the product (principally decarburization and recarburization). **Automatic temperature** controllers are actuated by thermocouples in the furnace. The thermocouple must not be located in the direct path of the flames, which are not only several hundred degrees hotter than the furnace temperature but are also of extremely variable temperature and not an indication of the average temperature. **Automatic control of atmosphere** for the consistent maintenance of good combustion is accomplished by properly proportioning the fuel and combustion air as they enter the furnace. This is accomplished by the utilization of some characteristic of the flow of one fluid to regulate the flow of the other fluid. **Automatic pressure** control operates the flue dampers of a furnace to maintain a constant predetermined pressure [usually about 0.01 to 0.05 in (0.25 to 1.25 mm) water] in the heating chamber, which excludes free oxygen from the surrounding atmosphere.

Table 7.3.5 Protective Gas Atmospheres

Type	Typical analysis					Dew point, °F (°C)
	CO ₂	CO	CH ₄	H ₂	N ₂	
I. Hydrogen, purified				100.0		- 60 (- 51)
II. Dissociated ammonia				75.0-5.0	25.0-95.0	
III. Rich hydrocarbon gas, not conditioned	5.5	9.0	0.8	15.0	69.7	+ 50 (10)
IV. Lean hydrocarbon gas, not conditioned	11.5	0.7		0.7	87.1	+ 50 (10)
V. Rich hydrocarbon gas, completely conditioned	0.1	9.5	0.8	15.8	73.8	- 60 (- 51)
VI. Lean hydrocarbon gas, completely conditioned	0.1	2.8		3.9	93.2	- 60 (- 51)
VII. Endothermic generator gas	0.5	20.0	1.0	38.0	40.5	+ 50 (10)

Care in furnace construction, operation, and maintenance is the simplest but often most neglected of all methods of heat savings. A large quantity of fuel can be saved by care in the construction of furnace refractories so that they will remain tight, by attention to the sealing of doors, by taking care that the doors and other openings are closed when not in use, and by maintaining insulation on any water-cooled members in the furnace.

SPECIAL ATMOSPHERES

(See also Sec. 7.5.)

In an increasing number of heat-treating operations, the necessity for improved quality has created a demand for clean- or bright-heating furnaces, in which the heating material is surrounded by a suitable protective gas while it is heated by radiation from electric resistors, radiant tubes, or the walls of a muffle. Table 7.3.5 gives the chemical analysis of common protective gases used in the heat-treating industry.

Type I Purified hydrogen is used for annealing, brazing, and other treatment of low-carbon steel; for the sintering of low-carbon ferrous powders; for the treatment of silicon iron (electrical sheets and strip); for the bright annealing of stainless steels, and the sintering of molybdenum, tungsten, and other metals.

Type II Ammonia is dissociated by steam or electric heat, and is dried by chemical driers. By partial combustion the relative percentages of hydrogen and nitrogen may be varied as shown in Table 7.3.5. The resulting gases from this treatment are cheaper and are used for brazing and sintering copper alloys, and for annealing low-carbon steels. Dissociated ammonia without combustion is used for annealing stainless

steels containing nickel, short-cycle heating of all carbon and alloy steels, treatment of silicon iron, and the treatment of cuprous products.

Type III Rich hydrocarbon gas is produced by combustion with about 60 percent of theoretical air (6 : 1 air/gas ratio when using natural gas) in the presence of a nickel catalyst, followed by cooling to reduce the moisture content. It is used for the annealing of low-carbon steels, for short-cycle hardening of low-carbon steels, for clean annealing of chrome-type stainless steels, for treatment of silicon iron, and for brazing of copper alloys.

Type IV This gas is similar to type III except that about 90 percent of theoretical air is used for combustion. It is used for bright annealing of copper (straight N₂ and CO₂ can also be used for this purpose) and for clean heating of brass and bronze.

Type V This gas is the same as type III but is conditioned by chemical removal of carbon dioxide by monoethanolamine and by drying in chemical driers. It is used for short-cycle treatment of all carbon, alloy, and high-speed steels; for sintering of all ferrous powders; and as a carrier gas for carburizing and carbon restoration with the addition of natural gas or propane.

Type VI This gas is similar to type V except that about 90 percent of theoretical air is used in the combustion. The resulting gas is used for long-cycle treatment of all ferrous materials except stainless steels containing nickel, and is effective in controlling decarburization in all carbon and alloy steels. It is also used for the annealing of brass and bronze.

Type VII This endothermic gas is made in an externally heated generator with only 25 percent of theoretical air and is cooled to reduce moisture. It is used for short-cycle (under 2 h) heat treating and brazing, usually with small furnace installations. It is also used for dry cyaniding and as a carrier gas for carburizing and carbon restoration.

7.4 INCINERATION

by Charles O. Velzy and Roger S. Hecklinger

REFERENCES: *Proc. Biennial ASME National Waste Processing Conf.*, 1964-1994. "Design Considerations in Heat Recovery from Refuse," International Symposium on Energy Recovery from Refuse, 1975. Velzy et al., eds., "CRC Handbook on Energy Efficiency," chap. 4, Waste-to-Energy Combustion, in press. "Steam, Its Generation and Use," 40th ed., Babcock and Wilcox Co. Kirklín et al., The Variability of Municipal Solid Waste and Its Relationship to the Determination of the Caloric Value of Refuse Derived Fuels, *Resources and Conservation*, 9, 1982, pp. 281-300.

Incineration is a method for processing of solid wastes by the burning of the combustible portions. It reduces the volume of solid wastes and eliminates the possibility of pollution of groundwater from putrescible organic waste, and the residue may serve as a source of mineral constituents and as a fill. With the application of boilers, beneficial use of the energy generated from burning of the waste is possible.

NATURE OF THE FUEL

The refuse which is received at an incinerator today will contain a high proportion of paper; plastics; some wood; vegetable and animal waste; and varying amounts of cloth, leather, and rubber—together with metal cans, glass, and other noncombustible matter. Collections may also include metal appliances, furniture, tree limbs, other yard waste, waste building material, broken concrete, and other coarse waste matter, commonly classified as rubbish. With little or no regulation of the handling of refuse by the homeowner, there may be a wide variation in moisture content of refuse, depending on the weather. Thus, after a storm, the moisture content may be so high that it is difficult to sustain combustion. Industrial and hazardous waste should be specifically identified and combustion facilities designed for the particular waste.

TYPES OF FURNACES

The type of furnace for incinerators is dictated largely by the type of grate around which the furnace is built. Except in small plants, the modern furnace is equipped with a mechanical grate.

The "Controlled Air" Furnace In the late 1970s, a type of combustion unit, batch fed, utilizing two chambers for staged combustion and followed by a waste heat boiler, was installed in smaller communities in the United States. Such units, while less efficient than larger furnaces, can be factory assembled in large segments (or modular components) and therefore are less expensive than large, field-erected units. Thus they extended the economics of energy-from-waste plants to the smaller communities. In such plants, the refuse is normally dumped on a receiving floor and is then pushed into a ram for feeding into the combustion units. The smallest units do not have grates, while larger units are fitted with rams to move the material through the furnace as it is burned.

The Rectangular Furnace Mechanical-grate furnaces are rectangular in shape, with movement provided by travel of the grate or by a reciprocating or rocking action of the grate sections. Refuse is fed by gravity through a vertical chute, by a ram or similar arrangements.

PLANT DESIGN

Capacity The capacity to be provided is a function of (1) the area and population to be served; (2) the number of shifts (one, two, or three) the plant is to operate; and (3) the rate of refuse production for the population served. If records of collections have been kept, the capacity can be determined and forecasts made; lacking records, the quantity of refuse may be estimated as approximately 4 lb (1.8 kg) per capita per day, when there is little or no waste from industry, to 5 lb (2.3 kg) per capita per day where there is some waste from industry. A small plant (100 tons/d) [90 metric tons per day (t/d)] will probably operate one shift per day; for capacities above 400 tons (360 t) per day, economic considerations usually dictate three-shift operation.

Location An isolated site may be preferred to avoid the possible objections of neighbors to the proximity of a waste disposal plant. However, well-designed and well-operated incinerators which do not present a nuisance may also be installed in light industrial and commercial areas, thereby avoiding the economic burden of extended truck routes. Since considerable vertical distance is involved in passing refuse through an incinerator, there is an advantage in a sloping or hillside site. Collection trucks can then deliver refuse at the higher elevation while the residue trucks operate at the lower elevation with a minimum of site grading.

Refuse-Handling Facilities Scales should be provided for recording the weight of material delivered by collection trucks. Trucks should then proceed to the tipping floor at the edge of the storage pit. This area, which may be open or enclosed, must be large enough to permit more than one truck at a time to maneuver to and from the dumping position.

Since collections usually are limited to one 8-h daily shift (with partial weekend operation) while burning may be continuous over 24 h, ample storage must be provided. Seasonal and cyclic variations must also be considered in establishing the storage requirements.

Refuse storage in larger plants is normally in long, narrow, and deep pits extending either along the front of the furnaces, or split in two halves extending from either side of the front end of the furnace. If the pit is much over 25 ft in width, it is generally necessary to rehandle refuse dumped from trucks. In smaller plants, floor dumping and storage of refuse is common practice.

Feeding the Furnaces In a large incinerator (pit and crane type), burning continuously, refuse is transferred from storage pit to furnace hopper by a crane equipped with a grapple. (See Sec. 10.) Batch feeding or batch discharge of residue is undesirable because of the resulting variations in furnace temperatures, adverse impact on furnace side walls, and increased air emissions.

In a more modern furnace using mechanized grates, a vertical charging chute, 12 to 14 ft (3.6 to 4.2 m) long, leads from the hopper to the front end of the furnace. This chute is kept full of refuse; feeding is accomplished by the operation of the mechanical grate, or by a ram; the front of the furnace is sealed from cold air; and the fuel is spread over the grate in a relatively thin bed.

In some newer plants, conveyors, live-bottom bins, and shredding and pneumatic handling of the combustible fraction of the refuse have been utilized to produce a refuse-derived fuel (RDF). See Fig. 7.4.1.

FURNACE DESIGN

The basic design factors which determine furnace capacity are grate area and furnace volume. Both provision for and quantity of underfire air, and provision for quantity and method of applying overfire air influence capacity. The required grate area depends upon the selected burning rate, which varies between 60 and 90 lb/(ft² · h) of refuse in practice. Conservative design, with reasonable reserve capacity and reasonable refractory maintenance, calls for a burning rate between 60 and 70 lb/ft² of grate area.

Furnace volume is a function of the rate of heat release from the fuel. A commonly accepted minimum volume is that which results from a heat release of 20,000 Btu/(ft³ · h). Thus, at this rate, if the fuel has a heat content of 5,000 Btu/lb, the burning rate would be 4 lb/(h · ft³) of furnace volume. A conservative design, allowing for some overload and possible quantities of refuse of high heat content, would be from 30 to 35 ft³/ton of rated capacity.

The primary objective of a mechanical **grate** is to convey the refuse automatically from the point of feed through the burning zone to the point of residue discharge with a proper depth of fuel and in a period of time to accomplish complete combustion. The rate of movement of the grate or its parts should be adjustable to meet varying conditions.

A secondary, but important, objective is to stir gently or tumble the refuse to aid in completeness of combustion. In the United States, there are several types of mechanical grates: (1) traveling, (2) rocking, (3) reciprocating, and (4) a proprietary water-cooled rotary combustor. With the traveling grate, stirring is accomplished by building the grate in two or more sections with a drop between sections to tumble the material. The reciprocating and rocking grates tumble the material by movement of the grate elements. The rotary grate slowly rotates to tumble the material which is inside the cylinder. In Europe, variations of the U.S. designs as well as other types have been developed. The Volund incinerator (Danish) uses a slowly rotating, refractory-lined cylinder or kiln through which the fuel passes as it is burned; the so-called Duesseldorf grate uses a series of rotating cylindrical grates in an inclined arrangement.

Furnace configuration is largely dictated by the type of grate used. When built with a mechanical grate, the furnace is rectangular in plan and the height is dependent upon the volume required by the limiting rate of heat release.

The total air capacity provided in a refractory-walled incinerator must be more than the theoretical amount required for combustion in order to obtain complete combustion and to control temperatures—particularly with dry, high-heat-content refuse. The total combustion-air requirements may range to 10 lb of air/lb of refuse. For the modern mechanical-grate furnace chamber, two blower systems should be provided to supply combustion air to the furnace. Blower capacities can be divided, with half or more from the underfire blower and somewhat less than half from the overfire blower and with dampers on fan inlets and air distribution ducts for control. The pressure on the underfire system for most U.S. grate systems approximates 3 in. of water. The pressure on the overfire air should be high enough so that the jet effect on passage through properly proportioned and distributed nozzles in the furnace roof and walls produces sufficient turbulence and retains the gases in the primary furnace chamber long enough to ensure complete combustion.

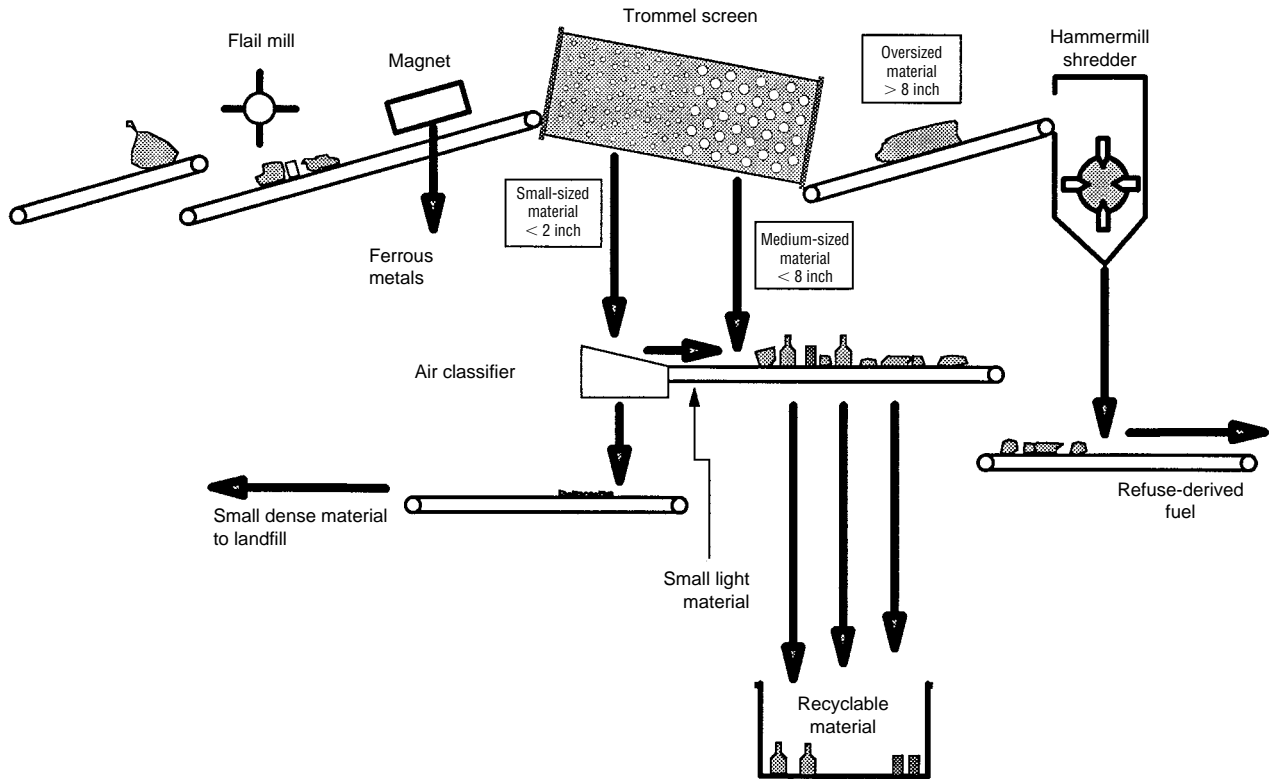

Fig. 7.4.1 Process diagram for a typical RDF system. (Roy F. Weston, Inc.)

Heat Recovery Perhaps the most potentially attractive form of recovery, or extraction, of resources from municipal solid wastes is recovery of energy from the incineration process.

Several options exist when one is considering recovery of energy from incineration. These options include mass burning in a refractory-

walled furnace with a waste-heat boiler inserted in the flue downstream; mass burning in a water-walled furnace with the convection surface immediately downstream; and refuse preprocessing and separation of the combustible fraction with combustion taking place in a utility-type boiler partially in suspension and partially on a grate. This latter option

Table 7.4.1 Energy-from-Waste Plants Larger than 300 tons/day Commissioned 1990–1995

Plant location	Plant size (tons/d)	Start-up year	Type	Energy sold
Broward County, FL, north	2,250	1991	Mass burn water wall	Electricity
Broward County, FL, south	2,250	1991	Mass burn water wall	Electricity
Camden, NJ	1,050	1991	Mass burn water wall	Electricity
Chester, PA	2,688	1991	Rotary kiln water wall	Electricity
Essex County, NJ	2,250	1990	Mass burn water wall	Electricity
Fort Myers, FL (Lee County)	1,200	1994	Mass burn water wall	Electricity
Gloucester County, NJ	575	1990	Mass burn water wall	Electricity
Honolulu, HI	2,165	1990	RDF water wall	Electricity
Hudson Falls, NY	400	1992	Mass burn water wall	Electricity
Huntington, NY	750	1991	Mass burn water wall	Electricity
Huntsville, AL	690	1990	Mass burn water wall	Steam
Kent County, MI	625	1990	Mass burn water wall	Electricity/steam
Lake County, FL	528	1991	Mass burn water wall	Electricity
Lancaster County, PA	1,200	1991	Mass burn water wall	Electricity
Long Beach, CA	1,380	1990	Mass burn water wall	Electricity
Lorton, VA (Fairfax County)	3,000	1990	Mass burn water wall	Electricity
Montgomery County, PA	1,200	1991	Mass burn water wall	Electricity
Pasco County, FL	1,050	1991	Mass burn water wall	Electricity
Rochester, MA	2,700	1988/1993	RDF water wall	Electricity
Southeast CT (Preston, CT)	600	1992	Mass burn water wall	Electricity
Spokane, WA	800	1991	Mass burn water wall	Electricity
Union County, NJ	1,440	1994	Mass burn water wall	Electricity
Wallingford, CT	420	1990	Mass burn water wall	Electricity/steam

is generally termed combustion of a refuse-derived fuel. A list of water-wall and RDF plants in North America in start-up or operation as of the end of 1994 extracting energy from combustion of municipal-type waste is shown in Table 7.4.1. This list excludes plants built for developmental or experimental purposes and plants that utilize specialized industrial wastes.

Figure 7.4.2 illustrates a plant with heat recovery, while Fig. 7.4.3 shows a cross section through a typical RDF facility.

In considering the above options, one should taken into account the overall energy balance in the various systems. These systems can be grouped under the following general categories: burning as-received refuse; burning mechanically processed refuse; burning thermochemically processed refuse; and burning biochemically processed refuse. In all the processing systems, less heat will be available for use than there was prior to processing.

The tabulation below from published data regarding the production of a fuel gas from refuse will partially illustrate the net energy loss in converting the available energy to another form:

Composition	Percent by volume	Percent by weight	Percent of total carbon
CO	47	62.1	70
H ₂	33	3.1	
CO ₂	14	29.1	21
CH ₄	4	3.0	6
C ₂ H ₂	1	1.4	3
N ₂	1	1.3	

Note that 21 percent of the carbon is in CO₂ which will not burn, while 70 percent of the carbon is in CO where 30 percent of the elemental energy in carbon is no longer available. While this heat is not wasted, it is lost energy not available to do further work.

A tabulation of energy losses and total net available energy, based on information published in 1974–1975 for refuse with an initial heat content of 4,400 Btu/lb, is given in Table 7.4.2.

Of the 4,400 Btu/lb in the refuse as received, the tabulated data indicate the useful energy that may be made available through combustion. While the data are not absolute, the relative magnitudes are meaningful, provided similar degrees of design efficiency and sophistication of control are used for each process.

Other factors to consider in selection and design of heat-recovery facilities include efficiency of boiler facilities, furnace-chamber design, and combustion air supply. While in older plants with waste-heat boilers installed in downstream flues, steam production averaged 1.5 to 1.8 lb/lb of refuse, in newer water-walled furnaces and suspension-fired units, steam production is of the order of 3.0 lb/lb of refuse. The lower efficiency in waste-heat boiler units is due to higher heat losses in the plant stack effluent, in turn caused by higher excess air levels required to control combustion temperatures properly in the refractory-lined primary furnace enclosure.

In most water-walled furnaces and furnaces in which shredded combustible refuse fractions are burned, the usual configuration is a tall primary chamber with the gases passing out the top and into the convection boiler surface after completion of combustion. It has been found desirable in mass-burning water-wall plants to coat a substantial height of the primary combustion chamber (where boiler-tube metal temperatures will exceed 500°F) with a refractory material and to limit average gas velocities to under 15 ft/s. Gas velocity entering the boiler convection bank should be less than 30 ft/s. Water-table studies have been found to be very useful in checking combinations of furnace configurations and introduction of combustion air.

In mass burning, combustion air is usually supplied from both under and over the grate. This is not necessarily the case when burning prepared refuse. In a water-wall mass-burning type of furnace, overfire air is utilized to enhance turbulence and mixing of combustion gases with the combustion air, and for completion of combustion. Accordingly, this air is best introduced through numerous relatively small (1½- to 3-in-diameter) nozzles, at pressures of 20 in of water and higher. Ideally, provision should be made for the introduction of the overfire air at several different elevations in the furnace.

As this nation's energy needs become more critical in the future, this readily available source of energy should be tapped more frequently. The technology is available now for successful application of these techniques if provision is made for adequate funding and properly trained operating staffs.

Flues and chambers beyond the furnace convey gases to the stack and house facilities for removal of fly ash and other pollutants. The draft for an incinerator furnace may be provided by a stack of adequate diameter and height or by an induced-draft fan. (See Secs. 4 and 14.) Most modern plants include heat recovery equipment and extensive air pollution

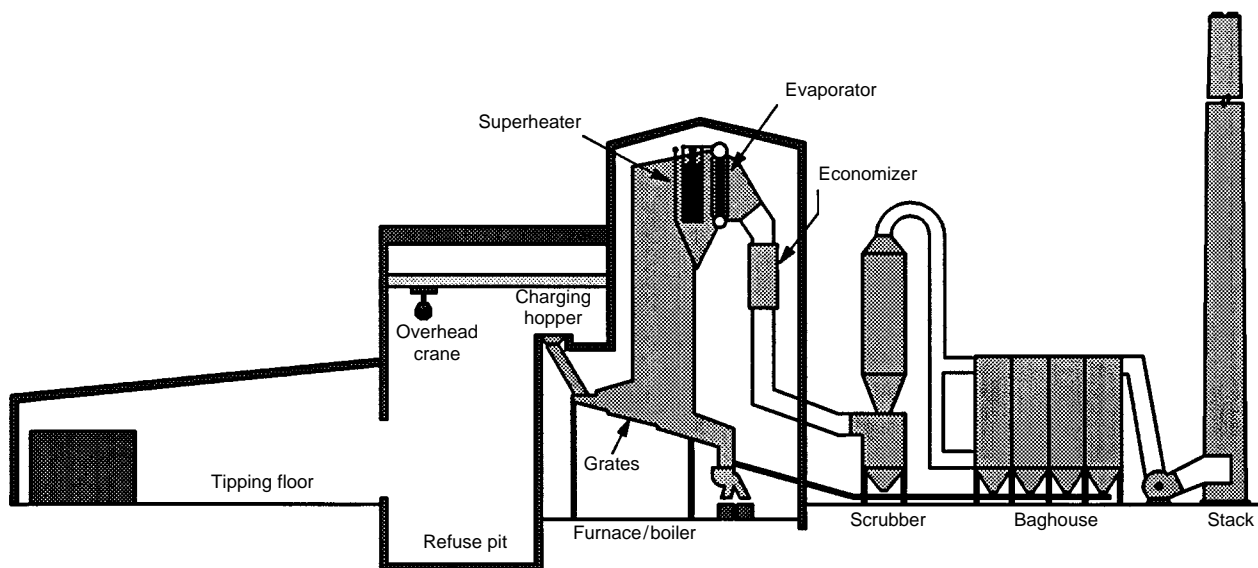

Fig. 7.4.2 Typical cross section of a mass burn facility. (Roy F. Weston, Inc.)

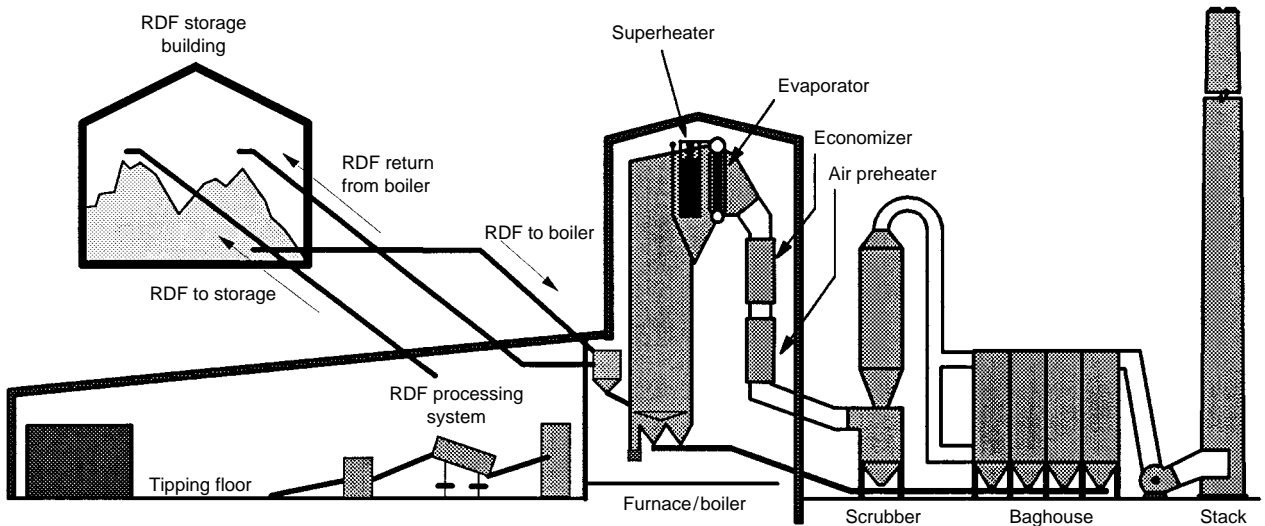

Fig. 7.4.3 Typical cross section of an RDF facility. (Roy F. Weston, Inc.)

control equipment. In these plants, draft losses are so high that an induced-draft fan is required.

Air Pollution Control The federal new source emission standard for air pollution control at new or enlarged municipal sized incinerators is 0.015 grain per dry standard cubic foot (gr/DSCF) (34 mg/DSCM) corrected to 7 percent O_2 . (This is approximately 0.03 lb/1,000 lb of flue gas corrected to 50 percent excess air.) Some jurisdictions have promulgated emission requirements lower than the federal standards. Designers of modern plants will also have to include facilities to reduce acid gas emissions and, at some plants, NO_x and mercury emissions.

To meet current emission requirements, two basic techniques have been utilized on incinerators: electrostatic precipitation and fabric filters preceded by lime addition in a slurry, so-called "dry scrubbing." Electrostatic precipitation has performed reliably and has given predictable emission test results. The fabric filter/dry scrubber air pollution control system is considered by many to represent the most efficient combination of pollution control systems currently available for particulates and acid gases. Nonselective catalytic reduction using ammonia has been applied at some plants for NO_x control, while limited experience has been gained in the use of activated carbon for control of mercury emissions. Good combustion control is used to limit emission of organics.

Residue Discharge and Disposal The residue from refuse burning consists of relatively fine, light ash mixed with items such as burned tin cans, partly melted glass, and pieces of metal. Discharge from furnaces may be through manually operated dump grates or from mechanically operated grates to a hopper, where it is quenched and delivered to a

truck through a bottom gate. The residue may also be discharged through a chute into a conveyor trough filled with water for quenching and then carried by flight conveyor to an elevated storage hopper for truck delivery. Usually there are two conveyor troughs, so arranged that the residue can be discharged to either, one trough being used at a time. A European system uses a ram discharger submerged in a water-filled container.

The lower end of the discharge chute leading to the trough is submerged in a water seal to prevent entrance of cold air to the furnace. In design of the conveyor mechanism, the proportions should be large because of the nature of the material handled, and the metal used should be selected to withstand severe abrasive service. Final disposal of the residue is by dumping at a suitable location, which for modern plants usually means a monofill. Volume required for disposal is 5 to 15 percent of that required for dumping raw refuse.

Miscellaneous Facilities Good working environment and reasonable comfort for the staff should be provided.

COMBUSTION CALCULATIONS

Among the factors directly affecting design are **moisture** and **combustible content** of refuse as received, heat released by combustion, temperature control, and water requirements. The design of furnaces, chambers, flues, and other plant elements should be based on characteristics which result in large sizes. Controls should provide satisfactory operation for loads below the maximum. The computations which follow are for relatively high heat releases.

The prime factors in **heat calculations** are the moisture and combusti-

Table 7.4.2 Energy Losses and Total Net Available Energy for Refuse with Initial Heat Content of 4,400 Btu/lb, 1974-1975

Process	Energy loss, %			Total net available energy Btu/lb
	Processing	Combustion	Total	
As received	1	39	40	2,640
Dry shredding	18	30	48	2,288
Wet shredding	35	21	56	1,936
Pyrolysis, oil	62	9	71	1,276
Pyrolysis, gas	32	25	57	1,892
Pyrolysis with oxygen	37	15	52	2,112
Anaerobic digestion	72	6	78	968

ble content of the refuse and heat released by burning the combustible portion of the refuse. The moisture content may vary from 20 to 50 percent by weight, and the combustible content may range from 25 to 70 percent. The combustible portion is composed largely of cellulose and similar materials, mixed with proteins, fats, oils, waxes, rubber, and plastics. The heat released by burning cellulose is approximately 8,000 Btu/lb, while that released by the plastics, fats, oils, etc., is approximately 17,000 Btu/lb. If cellulose, plastics, oil, and fat exist in the refuse in the ratio of 5 : 1, the heat content of the combustible matter will be 9,500 Btu/lb. The heat content per pound of refuse as received, for varying proportions of moisture and noncombustibles, is given in Table 7.4.3 and Fig. 7.4.4

Determination of the **air requirement** is illustrated by computation with refuse of 5,000 Btu/lb heat content where (from Fig. 7.4.4) the composition is: combustible, 58.6 percent; noncombustible, 19.0 percent.

Carbon and hydrogen are the essential fuel elements in combustion of refuse; sulfur and other elements which oxidize during combustion are present in trace amounts and do not contribute significantly to the heat of combustion. Carbon and hydrogen content can be determined from a complete analysis of the refuse, but such an analysis is of questionable value because of the variable character of refuse and the difficulty of obtaining representative samples. For the purpose of this computation, a typical analysis is used in which the total carbon is 28 lb and the hydrogen 1.5 lb/100 lb of refuse. It is probable that 1 to 3 lb of combustible material per 100 lb of refuse will escape unburned with the residue. For the sake of clarity in the illustrated computations, complete combustion is assumed.

Oxygen requirements and products of combustion can be determined from the reactions as follows:

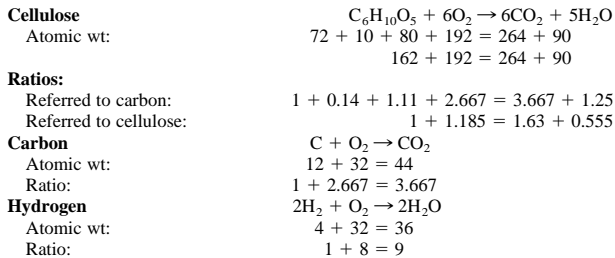

The theoretical air required per 100 lb of refuse follows from these figures where air is considered to contain 23.15 percent oxygen.

$$\text{Air required} = 28 \times 2.667/0.2315 + 1.5 \times 8/0.2315 = 374.4 \text{ lb/100 lb refuse}$$

For incineration, furnace temperature must be controlled to minimize refractory maintenance. With no other provision for heat absorption, it is necessary to introduce excess air well beyond the needs for complete

combustion, e.g., 140 percent of theoretical so that, in the example cited:

$$\text{Total air} = 1.8 \times 374.4 = 674 \text{ lb/100 lb refuse}$$

To summarize the quantities for a computation of furnace temperature, a materials balance is given in Table 7.4.4 equating the input to the furnace and output for 100 lb of refuse. In this tabulation, allowance is

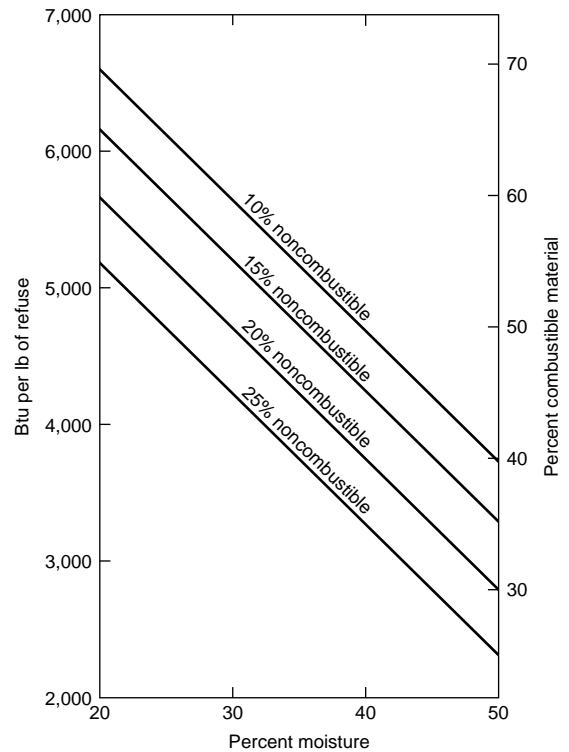

Fig. 7.4.4 Moisture-heat content relation with 9,500 Btu/lb combustible material.

made for moisture in the air at a commonly accepted rate of 0.0132 lb/lb of dry air. Some residue quench water will be evaporated, and the moisture added to the flue gases is estimated at 5 lb for each 100 lb of refuse burned. Since the assumed analyses are not precise, an exact balance is not obtained, but the indicated computations are sufficiently accurate for incinerator design.

Table 7.4.3 Heat Content of Refuse, as Received

Moisture, %	Noncombustible, %							
	10		15		20		25	
	Comb., %	Heat content*	Comb., %	Heat content*	Comb., %	Heat content*	Comb., %	Heat content*
50	40	3,800	35	3,325	30	2,850	25	2,375
40	50	4,750	45	4,275	40	3,800	35	3,325
30	60	5,700	55	5,225	50	4,750	45	4,275
20	70	6,650	65	6,175	60	5,700	55	5,225

* Btu/lb.

Table 7.4.4 Materials Balance for Furnace lb/100 lb of Refuse

Input:			
Refuse			
Combustible material			
Cellulose	43.75		
Plastics, oils, fats, etc.	<u>8.75</u>	52.5	
Moisture		25.0	
Noncombustible		<u>22.5</u>	100.0
Total air, at 140% excess air			
Oxygen	156.0		
Nitrogen	<u>517.9</u>	673.9	
Moisture in air		8.9	
Residue quench water		<u>5.0</u>	
Total		<u>787.8</u>	
Output:			
CO ₂ (28 × 3.667)			102.7
Air			
Oxygen (156-87)	69.0		
Nitrogen	<u>517.9</u>	586.9	
Moisture			
In refuse		25.0	
From burning cellulose		24.3	
From burning hydrogen		13.5	
In air		8.9	
In residue quench water		<u>5.0</u>	
Furnace gas subtotal		<u>766.3</u>	
Noncombustible material		22.5	
Unaccounted for		<u>-1.0</u>	
Total		<u>787.8</u>	

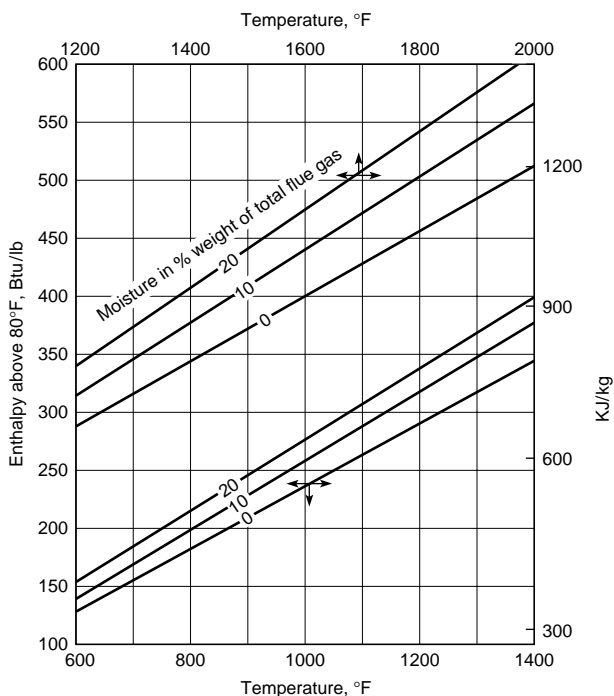

Fig. 7.4.5 Enthalpy of flue gas above 80°F.

In Table 7.4.4, total air is broken down into oxygen and nitrogen on the basis that 23.15 percent of the air is oxygen. To compute the air in the "output," or flue gas, the nitrogen is the same as the "input." Oxygen is diminished by the amount consumed in combustion. Since carbon and hydrogen unite with oxygen during combustion, the oxygen consumed per 100 lb refuse is:

$$\begin{aligned} \text{For carbon, } 28 \times 2.667 &= 74.68 \text{ lb} \\ \text{For hydrogen, } 1.5 \times 8 &= 12.00 \text{ lb} \\ \text{Total} &= 86.68, \text{ say } 87 \text{ lb} \end{aligned}$$

The moisture from burning cellulose and hydrogen is: for cellulose, $0.555 \times 43.75 = 29.3$ lb; for hydrogen, $9 \times 1.5 = 13.5$ lb.

Adiabatic flame temperature is the maximum theoretical temperature that can be reached by the products of combustion of a specific fuel-air combination. To calculate this temperature, the total heat input in the fuel is adjusted to subtract the heat input required to vaporize moisture in the fuel, moisture produced in combustion of cellulose and hydrogen, and the residue quench water that is vaporized. A loss is assumed to account for incomplete combustion and other small losses. The remaining heat energy is the sensible heat available in the furnace gas. It can be calculated per 100 lb of refuse from the data of Table 7.4.4 and the enthalpy data of Fig. 7.4.5 as follows:

Input, 100 lb × 5,000 Btu/lb		500,000 Btu
Losses:		
Heat of vaporization deduction		
Moisture		
In refuse	25.0	
From burning cellulose	24.3	
From burning hydrogen	13.5	
From residue quench	<u>5.0</u>	
	<u>67.8</u>	
67.8 × 1,050 Btu/lb		71,900
Assumed loss due to incomplete combustion and other losses 2%		<u>10,000</u>
Total deduction		- 81,900
Sensible heat available in furnace gas		418,810 Btu
Enthalpy of gas, 418,810 Btu ÷ 766.3 lb		547 Btu/lb
% Moisture in furnace gas		
Moisture vaporized	67.8	
Moisture in air	<u>8.9</u>	
	<u>76.7</u>	
76.7 ÷ 766.3 = 10.0%		
Temperature of furnace gas at 547 Btu/lb and 10.0% moisture from Fig. 7.4.5		1,950°F

RECOVERY

Many modern waste-to-energy (WTE) plants incorporate waste processing/materials recovery facilities. Such facilities are a natural adjunct at plants producing RDF. Relatively active stable markets have developed for newsprint, glass, metals, and certain specific plastics. Recent surveys of waste composition indicate that after recycling, paper and noncombustibles have decreased slightly while high-heat-value plastics have increased significantly as a percentage of municipal solid waste going to disposal. The impact of these changes in waste composition has been to increase slightly the heat content of waste available for processing in WTE plants and to remove some of the more troublesome materials from a materials handling standpoint.

Fly ash has been used to a limited extent as a concrete additive and as a road base. **Incinerator residue** has been used for land reclamation in low areas and, in some cases, as a road-base material. Generally, before such use, the fly ash and residue must be tested to ensure that they cannot be classified as hazardous waste.

7.5 ELECTRIC FURNACES AND OVENS

by George J. Roddam

REFERENCES: Robiette, "Electric Melting and Smelting Practice," Griffin, Campbell, "High-Temperature Technology," Wiley. "Electric-Furnace Steel Proceedings," Annual, AIME. Paschkis, "Industrial Electric Furnaces and Appliances," Interscience. Stansel, "Induction Heating," McGraw-Hill. Ess, The Modern Arc Furnace, *Iron Steel Eng.*, Feb. 1944.

CLASSIFICATION AND SERVICE

The furnaces and ovens addressed in this section generally are those small and medium-size units used in general foundry practice, heat treating, and associated processes. The larger units are generally used for melting large quantities of metal as part of specific production processes such as the production of high-purity alloy steels, processing batches of processed parts receiving vitreous enamel, annealing glass, and so on.

In **resistor furnaces and ovens**, heat is developed by the passage of current through distributed resistors (heating units) mounted apart from the charge. Alternating current of a standard power frequency is used. The furnace service is for heat applications to solids such as heat treatment of metals, annealing glass, and firing of vitreous enamel. Oven service is limited to drying and baking processes usually below 500°F (260°C).

In **induction heaters** heat is developed by currents induced in the charge. The service is heating metals to temperatures below the melting points.

In **induction furnaces** heat is developed by currents induced in the charge. The service is melting metals and alloys.

In **arc furnaces** heat is developed by an arc, or arcs, drawn either to the charge or above the charge. Direct-arc furnaces are those in which the arcs are drawn to the charge itself. In indirect-arc furnaces the arc is drawn between the electrodes and above the charge. A standard power frequency is used in either case. Direct-current (dc) electric power is an alternative source of energy. The general service is melting and refining metals and alloys. The ladle arc furnace is used particularly when a charge of metal is to be processed primarily to refine its chemistry.

In **resistance furnaces** of the submerged-arc type, heat is developed by the passage of current from electrode to electrode through the charge. The manufacture of basic products, such as ferroalloys, graphite, calcium carbide, and silicon carbide, is the general service. Alternating current at a standard power frequency is used. An exception is the use of direct current where the product is obtained by electrolytic action in a molten bath, e.g., in the production of aluminum.

The **characteristics of electric heat** are:

1. Precision of the control of the development of heat and of its distribution.
2. The heat development is independent of the nature of the gases surrounding the charge. This atmosphere can be selected at will with reference to the nature of the charge and the chemistry of the heat

process. This freedom is often a primary reason for the use of electric heat.

3. The maximum temperature is limited only by the nature of the material of the charge.

The first two characteristics underlie the design of all electric heating apparatus. The third is utilized in thermal processes for the production of certain materials not obtainable in any other way.

RESISTOR FURNACES

Resistor furnaces may be either the batch or the continuous type. Batch furnaces include box furnaces, elevator furnaces, car-bottom furnaces, and bell furnaces. Continuous furnaces include belt-conveyor furnaces, chain-conveyor furnaces, rotary-hearth furnaces, and roller-hearth furnaces.

Standard resistor furnaces are designed to operate at temperatures within the range 1,000 to 2,000°F (550 to 1,200°C). For higher heating chamber temperatures, see Resistors, later in this section.

The **heating chamber** of a standard furnace is an enclosure with a refractory lining, a surrounding layer of heat insulation, and an outer casing of steel plate, or for large furnaces an outer layer of brick or tile, as indicated by Figs. 7.5.1 and 7.5.2. The hearth of a batch furnace often is constructed of a heat-resisting alloy, made in sections to prevent warping. In some continuous furnaces the conveyor forms the hearth; in others a separate hearth is required.

Insulating firebrick—a semirefractory material—is commonly used for the inner lining of the heating chamber. This material has thermal and physical properties intermediate between those of fire-clay brick and heat-insulating materials. A lining of this kind has less heat-storage capacity than a fire-clay brick lining, and its use accordingly decreases the time periods of heating and cooling the chamber and also decreases the stored-heat loss for a given cycle of operation. Other advantages are its high heat-insulating value and light weight.

The maximum temperature of the inner face of the layer of heat insulation determines the character of material required for the insulation. Practically all resistor furnaces have insulation made of diatomite. Composite wall structures with a 4½-in (11-cm) semirefractory lining and a 9- to 13-in (23- to 33-cm) layer of heat insulation represent general practice for standard furnaces. (See also Sec. 4.3.)

Atmospheres A mixture of air and the gases evolved from the charge constitutes a **natural atmosphere** in the heating chamber of a resistor furnace. The composition of such an atmosphere in a batch furnace is variable during a heating cycle. A natural atmosphere in the heating chamber of a continuous furnace is mainly air. Natural atmospheres are used where the extent of the action of oxygen on the charge during the heating cycle is not objectionable and for processes where that chemical action is desired. (See also Sec. 7.3.)

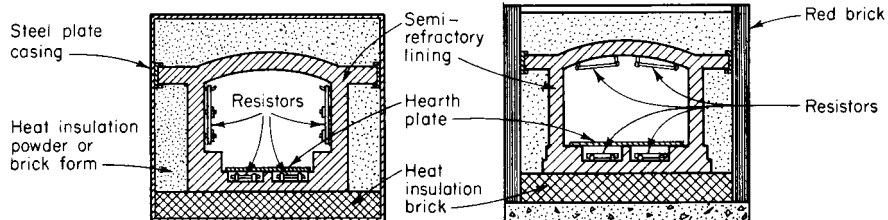

Fig. 7.5.1 Heating chamber with sidewall and hearth resistors.

Fig. 7.5.2 Heating chamber with roof and hearth resistors.

The basis of an **artificial atmosphere** is the exclusion of oxygen (air) from the heating chamber by the substitution of some other gas or mixture of gases. This gas or mixture of gases is selected with reference to the chemical activity of that atmosphere on the charge at the temperature of the heat application. A definite chemical action may be desired, for example, the reduction of any metallic oxide present on the charge, or it may be required that the artificial atmosphere to be chemically inactive. Thus artificial atmospheres are divided into (1) active or process atmospheres and (2) inactive or protective atmospheres. The term "controlled" atmosphere refers generally to a protective atmosphere, but it also includes artificial atmospheres of some degree of chemical activity. An example of a process atmosphere is the use of a hydrocarbon gas to carburize steel. Examples of controlled atmospheres are: the bright annealing of metals, the prevention of decarburization of steel during a heat application, the use of a reducing gas (hydrogen or carbon monoxide) in a copper brazing furnace, etc. In this last example the reducing gas serves to clean the faces of the joint to be made (by removal of any oxide present) and to maintain that cleanliness during the operation. The primary gases for controlled atmospheres are hydrogen and carbon monoxide and nitrogen.

The main uses of controlled atmospheres are (1) the prevention of the formation of oxides on the material of the charge, or conversely the reduction of any oxides present, and (2) the prevention of a change in the carbon content of a steel undergoing a heat treatment. Each of these uses denotes a chemical system in which the reactions are reversible.

The chemical systems relating to metallic oxides are:

A: Oxide + hydrogen \rightleftharpoons metal + water vapor

B: Oxide + carbon monoxide \rightleftharpoons metal + carbon dioxide

The chemical systems relating to carbon in steel are

E: Methane \rightleftharpoons hydrogen + carbon

F: Carbon monoxide \rightleftharpoons carbon dioxide + carbon

In artificial atmospheres the volume ratio of the two gases in the heating chamber should be so maintained as to correspond to the desired direction of the chemical activity of the system, or, if no chemical action is desired, to maintain that volume ratio at (or near) its equilibrium value for the temperature of the heat application. The equilibrium volume ratios for each of the four chemical systems A, B, E, and F for carbon steel over the usual range of temperature of heat-treatment processes and for atmospheric pressure are shown in Fig. 7.5.3. There is little tendency toward a change in the carbon content of a steel below the critical range. Oxidation is active down to about 1,100°F (650°C).

Curves E and F of Fig. 7.5.3 show the volume ratios of systems E and F for equilibria with graphite. The equilibrium volume ratios of these two chemical systems for carbon in solid solution in steel (austenite) depend in each case on the carbon content of the steel. For the methane-hydrogen-carbon system (E) the volume ratio of the two gases at equilibrium with carbon in an unsaturated steel at a given temperature is less than the value shown by curve E. For the carbon monoxide-car-

bon dioxide-carbon system (F) the volume ratio of the two gases at equilibrium with the carbon in low- and medium-carbon steel at a given temperature is somewhat greater than the value shown by curve F; for high-carbon steels the equilibrium volume-ratios approach the values of curve F.

In the case of the hydrogen-iron oxide reaction, curve A, the water vapor content of the mixture of gases at equilibrium decreases with decrease of temperature. Hence if a steel is to be cooled in a controlled atmosphere of this kind, the permissible water vapor content of the controlled atmosphere is dictated by the lowest temperature of the operation. The reverse is true of the carbon monoxide-iron oxide reaction, curve B. Thus if at a given temperature the carbon dioxide content of the mixture of carbon monoxide and carbon dioxide is less than the volume for equilibrium at that temperature it will be less than the volume for equilibrium at any lower temperatures and the steel can be cooled in that atmosphere without oxidation.

In the use of mixtures of the gases of the chemical systems noted to form controlled atmospheres for the heat treatment of steel, the interactions of the gases at elevated temperatures must be controlled by removal of all or nearly all the carbon dioxide and water vapor from the heating chamber.

The available data concerning controlled atmospheres for the protection of alloy steels during heat-treatment processes indicate that the technique for alloy steels is much the same as for carbon steels; i.e., a controlled atmosphere suitable for a carbon steel would, in general, be suitable for an alloy steel of the same carbon content.

In the heat treatment of nonferrous metals and alloys the use of either chemical system A or B requires for each oxide a knowledge of the equilibrium volume ratios of the chemical system used over the range of the operating temperature. Individual problems may arise. For example, copper can be bright-annealed in an atmosphere of dry steam—an inactive gas for this application—but the resultant staining of the copper during cooling may be objectionable. Copper usually contains a small percentage of oxide, and when annealing such copper in an atmosphere containing a reducing gas the temperature of the metal must be kept below about 750°F (420°C); otherwise the oxide will be reduced and the copper made brittle.

The foregoing discussion of atmosphere in heating chambers is intended to indicate the principles involved in the use of gases at elevated temperatures. The terms oxidation, reduction, carburization, and decarburization refer here to the chemical condition of a particular atmosphere and not to the extent of its effect on a charge. In all cases the concentration of the active gas or gases, time, temperature, in case of steel the carbon content and the gas pressure, and the catalytic action of hot surfaces within the chamber are important factors in the result obtained.

Bath Heating Heating for local hardening of edge tools is the most general service. The lead-bath furnace has a working temperature range of 650 to 1,700°F (360 to 950°C). The salt-bath furnace can be adapted to working-temperature ranges within a total range of 300 to 2,350°F (170 to 1,300°C) by the selection of suitable mixture of salts. The two salt baths most generally used are cyanide mixtures and chloride mixtures. The rate of heating by immersion is much faster than obtained by radiation. The rate of heat transfer in a salt bath is about one-half that in the lead bath. An additional use of the salt bath is for cyaniding, in effect a process atmosphere.

Resistors The resistor of a standard furnace is a sinuous winding mounted on the inner surfaces of the heating chamber as shown in Figs. 7.5.1 and 7.5.2. The resistor winding covers practically the entire surface of the space chosen. Resistors are applied on the basis of 2 to 3 kW/ft² (20 to 30 kW/m²) of wall surface in general practice. The basis of resistor location is radiation to all surfaces of the charge. Hence, the height and width dimensions of the heating chamber indicate the choice between sidewall and roof resistors. In some cases both locations are used. Uniform distribution of heat flow to the charge is obtained by a designed distribution of the surfaces of the resistors supplemented by reradiation from the inner surfaces of the chamber.

Resistors for the majority of standard furnaces are made of 80 Ni,

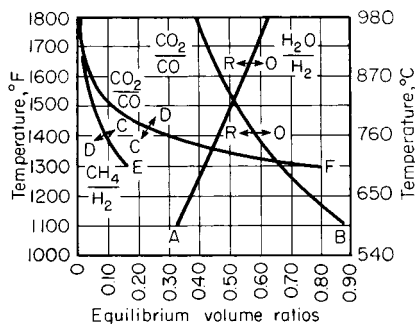

Fig. 7.5.3 Equilibrium volume ratios of chemical systems A, B, E, and F for steel. C = carburizing condition; O = oxidizing; D = decarburizing; R = reducing.

20 Cr alloy. A nickel-chromium-iron alloy is used in some furnaces for operation only over the lower portion of the furnace temperature range. Both ribbon and cast shapes are in use. The effort in each case is to obtain the maximum surface area per unit length of resistor and at the same time retain sufficient mechanical strength in the resistor winding.

The 80 Ni, 20 Cr alloy is self-protecting against oxidation, but this protection decreases with rise of temperature. The operating temperature of a resistor should be no higher than is needed in each case and should always be at a safe margin below the softening point of the alloy, which is about 2,500°F (1,390°C). This corresponds to a maximum furnace temperature of about 2,100°F (1,170°C). The life of a resistor is also affected by the frequency of heating and cooling. Barring accidents, the resistor of a standard furnace under average conditions of operation has a long life, usually measured in years of service.

The nickel-chromium alloy resistor is used in artificial atmospheres as well as in natural atmospheres. This alloy is not resistant to compounds of sulfur and is affected to some extent by carbon monoxide.

The electric insulation of the resistor circuit is that of its refractory supports at elevated temperatures. This limits the voltage of the circuit to about 600 V. Small furnaces are usually designed for 110 V, medium sizes for 220 V, and the larger units for 440 V. Single phase up to 25 or 30 kW and three phase for higher ratings is general practice.

The resistivity-temperature coefficient of the nickel-chromium alloy permits the operation of resistors of this material on constant-voltage circuits. The rate of heat development in a resistor is proportional to the square of the applied voltage; hence maintenance of normal voltage is desirable. Voltage regulation is not as important as for other types of electrical apparatus because of the heat-storage capacity of the structure of the heating chamber. The power factor of the resistor circuit is practically unity.

High-Temperature Furnaces **Silicon carbide** is the basis of a type of nonmetallic resistor for heating-chamber temperatures up to about 2,800°F (1,560°C). The material is formed into rods. Resistors of this material do not require protection against oxidation and are operated on constant-voltage circuits.

Molybdenum resistors are suitable for temperatures up to 3,000°F (1,670°C). Above that temperature the metal begins to vaporize. A molybdenum resistor cannot be operated in a natural atmosphere, and also it must be protected from reactions with silica and carbon. The metal is immune from reactions with sulfur compounds, nitrogen, and water vapor. Hydrogen is the most common artificial atmosphere used with molybdenum resistors. The difference between the cold and hot resistances of the circuit makes a starting device necessary.

Other materials used to some extent for resistors are iron, tungsten, and graphite. These require protection against oxidation.

Temperature Regulation The temperature of the heating chamber of a resistor furnace is in most cases regulated by a more or less intermittent application of current—the on-and-off method—which is made automatic by instrument control. This method utilizes the heat-storage capacity of the inner lining of the heating chamber as a temperature equalizer. The variation from the normal temperature of the chamber can be kept within less than 7°F (4°C) plus or minus, without undue wear of the temperature-control equipment. Temperature regulation by voltage control is equally applicable to resistor furnaces, and the trend is toward the use of this more accurate method particularly for the more important installations.

Temperature protection for resistor furnaces is obtained by means of a temperature fuse mounted in the heating chamber and connected in the control circuit of the power supply to the furnace.

Multiple-Temperature Control The resistors of the larger furnaces are divided into two or more circuits. Each circuit can be equipped with individual temperature control. That arrangement provides temperature regulation at more than one location in the heating chamber and is an aid toward maintaining uniform temperature distribution within the chamber.

The subdivision of resistor circuits is used also for zone heating—and zone cooling where needed—in continuous furnaces.

Melting Pots Resistor heating is applied to melting pots for the soft metals and alloys and for lead baths and for salt baths. The immersion heating unit is used for temperatures up to 950°F (530°C). For higher temperatures the metal pot is heated by resistors mounted outside and around the pot. The assembly in each case includes a heat-insulating wall similar to that of a resistor furnace. Another method of heating applicable only to salt baths is the passage of alternating current (of any frequency) between electrodes immersed in the bath.

Tempering Furnaces The temperature is comparatively low—below 1,300°F (720°C). Electrically heated oil baths and salt baths are used for tempering many kinds of small parts. Another form of tempering furnace is a vertical resistor furnace with the addition of a removable metal cylinder (or basket) to contain the charge and to provide an annular passageway for the circulation of air (by a fan mounted on the furnace) over the resistors and thence through the charge—an application of forced convection heating.

Sizes The electrical rating is the general method of expressing the size of a resistor furnace. Sizes up to 100 kW predominate, 100- to 500-kW furnaces are common, and others within the range 500 to 1,000 kW are in service. The data in Table 7.5.1 refer to common sizes of so-called box furnaces for general service.

The **losses** from a resistor furnace for a given heating chamber temperature are as follows: The open-door loss is a variable depending on the area of the door (or doors) and the percentage of the time that the door is open—from a continuous furnace this loss also varies with the type and speed of the conveyor; with artificial atmospheres, the loss of heat in the gases discharged for atmosphere control; the stored-heat loss, a variable that depends on the extent and frequency of the cooling of the furnace within a given period of operation; the heat dissipated from the outer surfaces of the furnace.

The **operating efficiency** is expressed as either pounds of material treated or kWh or kWh per ton. Representative values for average service for the heat treatment of steel range from 7 to 12 lb/kWh. Corresponding values for nonferrous metals and alloys are within the range 12 to 22 lb/kWh.

The general field of the batch furnace is defined by the following conditions: (1) intermittent and varied production; (2) long periods of heating (and in some cases slow cooling); (3) heating service beyond the range of the handling capacity of furnace conveyors; and (4) supplementary heating service. A continuous furnace is indicated where the flow of material to be heated is reasonably uniform and continuous, i.e., mass-production conditions. In some cases, batch furnaces with automatic charging and discharging equipment are essentially continuous furnaces.

Resistor Ovens The resistor oven is a modification of the resistor

Table 7.5.1 Box Resistor Furnaces, 1,850°F (1,030°C) Class

Connected load, kW	Power supply, 200 V	Steel, lb/h at 1,500°F	Time to heat to 1,500°F (830°C) when used previous day, min	Radiation, kWh/h, at 1,500°F	Approx dimension, in						
					Inside			Overall			
					Width	Depth	Height	Width	Depth	Height, door closed	Height, door open
29	1-phase	300	35	4.9	18	36	18	55	89	86	97
45	3-phase	500	35	6.9	24	54	20	61	108	90	101
60	3-phase	650	25	7.8	30	63	23	78	125	90	98
72	3-phase	750	25	9.1	36	72	23	84	135	90	98

furnace to correspond to the low temperatures of drying and baking processes. The heating chamber is an insulated metal structure with a fresh-air inlet and an exhaust fan for ventilation (the removal of vapors and gases evolved from the charge). A refractory lining is not required. Ovens may be of the batch type with conventional methods of handling the charge of the continuous type, usually with chain conveyors.

The most common type of electric oven is heated by resistors mounted in a separate compartment of the heating-chamber enclosure. The heat transfer is by forced convection which is accomplished by recirculation of the chamber atmosphere by a motor-driven fan.

A resistor oven with filament-type lamps as heating units provides what is generally known as infrared heating. The lamps, usually with self-contained reflectors, surround the charge, and the heat transfer is by radiation, mainly in the infrared portion of the spectrum. This type of oven is best adapted to the continuous heating of charges which present a large surface area in proportion to the mass and which require only surface heating, e.g., baking finishes on sheet products.

Ventilation The vapors and gases evolved from the charge during baking processes are often flammable, and the continuous discharge of these products from the oven chamber is essential for protection against explosions. For detailed recommendations, see *Pamphlet 74* of the Assoc. Factory Mutual Fire Ins. Cos., Boston.

DIELECTRIC HEATING

The term relates to the heat developed in dielectric materials, such as rubber, glue, textiles, paper, and plastics, when exposed to an alternating electric field. The material to be heated is placed between plate-form electrodes, as indicated in Fig. 7.5.4. It is not necessary that the electrodes be in contact with the charge; hence continuous heating is often practicable.

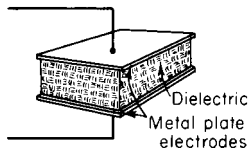

Fig. 7.5.4 Assembly for dielectric heating.

If the material of the charge is homogeneous and the electric field uniform, heat is developed uniformly and simultaneously throughout the mass of the charge. The thermal conductivity of the material is a negligible factor in the rate of heating. The temperatures and services are within the oven classification.

The frequency and voltage for this class of service depend in each case on the electrical properties of the material of the charge at the temperature specified for the heat application. The frequencies in use range from 2 to 40 MHz; the most common frequencies are from 10 to 30 MHz. It is advisable to select the frequency for heating by trial.

The upper limit of voltage across the electrodes is fixed by the spark-over value and by corona. The permissible voltage gradient depends on the nature of the material of the charge. Values within the range 2,000 to 6,000 V/in (790 to 2,400 V/cm) are found in practice; the voltage across the electrodes should not exceed 15,000 V.

Applications of dielectric heating include setting glue as in plywood manufacture, curing rubber, drying textiles, and the heat treatment of plastics.

INDUCTION HEATING

In induction heating, the lateral surface of the charge is exposed to an alternating magnetic flux. The currents thus induced in the charge flow wholly within its mass. The term "eddy-current heating" is sometimes applied to the method.

A common assembly, if the charge is to be heated to a temperature below its melting point, is to place the charge within a coil as indicated

in Fig. 7.5.5. An alternating current in the coil establishes the required alternating magnetic flux around the charge.

A peculiar feature of such assemblies, termed "induction heaters," is the absence of heat insulation; the coil is water-cooled. Thus, the charge is heated in the open air, or an artificial atmosphere can be used, if the assembly is enclosed. This requires rapid heating with heat cycles measured in minutes or seconds.

The frequency required is a function of the electric and magnetic properties of the charge at the temperature specified for the heat application and of the radius, or one-half the thickness, of the charge. This frequency for a given material increases with decrease of the dimension noted. The frequency in any case is not critical. In practice, 480, 960, 3,000, and 9,600 Hz and around 450 kHz suffice for the entire range of

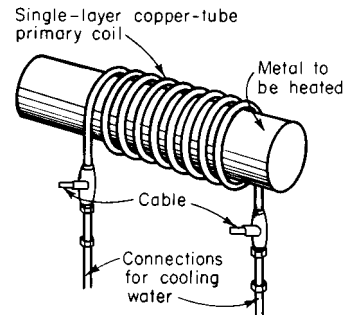

Fig. 7.5.5 Assembly for induction heating.

induction heating. The highest frequencies needed are those for heating steel charges to temperatures above the Curie point. About $\frac{1}{2}$ in ($\frac{1}{4}$ cm) diam in this case is the lower limit for 9,600 Hz. This limit dimension is decreased for steel heated to temperatures below the Curie point and for all charges of nonferrous materials.

The operation can be either batch heating or continuous heating as required. Applications include heating for forging, for annealing, for hardening steel, for brazing, soldering, and strain relief. As most of the heat is developed within the annular zone of the charge, the method is particularly well adapted to heating steel parts for surface hardening. A recent application of induction heating is the raising in temperature of billet-size ingots for rolling into merchant bars.

ARC FURNACES

Two types of arc furnaces are in common use: (1) the three-phase furnace and (2) the single-phase furnace. The general field of the three-phase furnace is the melting and refining of carbon and alloy steels; that of the single-phase furnace is the melting of nonferrous alloys. There is an increasing amount of arc-furnace capacity used for melting and refining various types of iron.

Three-Phase Arc Furnaces The general design of this type of furnace is shown in Fig. 7.5.6. In operation, each heat is started by swinging the furnace roof aside and then loading the refractory-lined furnace body with scrap dropped from a crane-handled clamshell charging bucket. Arcs next are drawn between the lower ends of the graphite electrodes and the scrap; melting proceeds under automatic control until the hearth carries the molten metal. This fluidizing stage is effected at about 85 percent thermal efficiency. Several charges usually are needed to build up the bath—particularly in ingot practice. The furnace tilts forward for pouring; the back tilt serves in the removal of slag and permits the furnace hearth to be kept in proper condition. The slagging door is opposite the pouring spout. Large furnaces frequently also have a side door, known as a working door.

Refractories Furnaces that produce foundry steels operate with acid lining. This means silica brick form the walls; the hearth is of gannister or the equivalent. Silica-brick roofs are the more widely used although, for intermittent operation, clay brick may be preferred. The

slags of acid-lining practice remove no phosphorus or sulfur. Essentially all ingot operations are carried on with basic linings. This means magnesite bottom and sidewalls, so that the limey slags employed will not erode them. Entry ports for the electrodes may be of extra-quality refractories to prolong roof life, particularly where the furnace is in continuous operation. In basic practice phosphorus joins the slag readily; sulfur can be removed next by a second slag, when this slag has been made highly reducing. Slag covering the molten bath serves in refining the metal and reduces the heating of wall and roof brick. In modern arc furnace operations, foamy slag practice is employed, wherein a deep, foamy slag prevents the arcs from damaging the wall and roof linings. Superrefractories find application in high-temperature, long-refining operations. Electric irons are made in acid-lined furnaces.

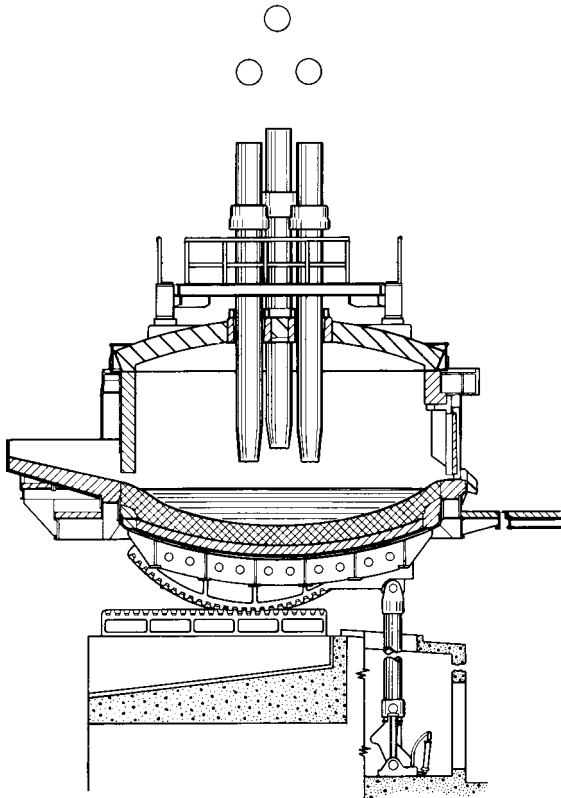

Fig. 7.5.6 Three-phase arc furnace with basic lining.

Temperature Arcs approximate 6,300°F (3,500°C); hence operation must be carried out so as to protect the refractories as much as possible. As the top-charge furnace now has supplanted the door-charge furnace in nearly all cold-melt work, the conditions for shielding the refractories during the melt-down stage of each heat are good. With the furnace filled to the top with scrap, the electrodes bore down through that scrap, and the heat of the arcs is liberated right in the metallic charge itself. When the charge, and any back charges made, approach the fluid stage it is customary to reduce both the power input and the length of arcs employed. During the finishing stages, roof and sidewalls are protected both by the slag and by the “umbrella” effect of the electrodes themselves. Deserving mention is the expanding use of oxygen to gain speed in production, which makes for increasing furnace temperatures. The higher sidewalls of modern furnaces aid in obtaining good roof life. Additionally, water-cooled sidewalls extend refractory life and thus minimize the cost of replacing refractory.

Charges The three-phase arc furnace is primarily a unit for con-

verting scrap charges into steel for pouring into ingots, castings, or a continuous caster. This type of equipment finds increasing use also in the cold melting and duplexing of gray and white irons. Hand and chute charging have practically disappeared, at least insofar as furnaces of a ton charge size upward are concerned. One of the main advantages of the top-charge furnace is that the scrap used does not need to be cut to door size, as was the case formerly.

Although first employed only for the more expensive grades of steel, the arc furnace now is used widely in making ingots for rolling into merchant bars and similar grades and supplies liquid metal fed into a continuous caster. The speed of production on this type of working—termed single-slag dephosphorizing basic practice—can be double that obtained with the same furnace used to make two slag dephosphorized and desulfurized basic alloy steels. Acid working on foundry steels generally approximates the same speed as single-slag dephosphorizing basic practice, and some alloy steels require about half again as much time. While most carbon steel for castings is made on an acid hearth, a basic bottom is regularly used for making manganese steels, for refining nickel and copper, and for the furnacing of many heat-resistant alloys. Section 13.1 discusses steel-foundry practice.

In general, approximately 320 kWh at 100 percent thermal efficiency will be needed to melt 1 ton of cold steel scrap. This means about 400 kWh will be needed to fluidize each ton. Additionally, about 100 kWh/ton will be needed to finish the heat and superheat the bath—this in the case of ordinary plain carbon steels made on single-slag acid or basic practice. Double-slag steel heats will require no more power than others for fluidizing the scrap charge, but the additional power needed for melting new slag, refining, melting added alloys, etc., may require as much as 250 kWh/ton of bath, or even more.

Three-phase arc furnaces are usually given an hourly productive rating in terms of acid foundry steels when these equipments are supplied in sizes up to and including the 11-ft (3.4-m) diam unit. However, with many furnaces extra-powered, quite a few shops exceed the normal hourly rating considerably—in some cases by essentially 100 percent. Representative sizes of furnaces are listed in Table 7.5.2.

Arcs The arc in each phase is maintained between the lower end of the electrode and the top of the charge (or bath, after the molten state is reached). Higher voltages can serve for melting as the size of the furnace increases; thus, where a 7-ft (2.1-m) diam furnace employs 215 V as its highest melting potential, a 15-ft furnace would use 290 V or higher as the top tap. For such a furnace constructed with water-cooled sidewall and roof panels, the application of 500 V would be normal. The furnace transformer is universally of the motor-operated tap-changer type, and in the case of, say, a 10,000 kVA at 55°C rise substation, a secondary voltage variation of more than 150 V is customary. The range of lower voltages used for refining the molten metal is obtained by changing the primary of the main transformer from delta to star connection; this reduces both voltage and capacity to 58 percent of their values with delta primary connection. If, say, 12 tons of steel scrap are to be melted down to fluid in 1 h, then the electric energy needed will approximate 5,000 kWh. With 245 V used as the principal melt-down voltage, the current per phase will have to average close to

Table 7.5.2 Sizes of Three-Phases Arc Furnaces

Diam of shell, ft	Normal charge, tons	Normal powering, kVA	Normal productive rate, single-slag steels, tons/h*
5	1½	600	½
7	3½	1,500	1½
9	8	3,000	3
11	16	6,000	6
12½	27	9,000	9
15	50	12,500	13
20	115	25,000	27
24	225	36,000	40

* Many users exceed these outputs, particularly those using burners and oxygen to speed operations.

12,000 A. A 12-in (30-cm) diam graphite electrode would amply carry this current. Small furnaces operate with 600 kVa and even higher powering per ton of charge, whereas in the case of the larger equipments the electrical backing of the furnace normally does not exceed 300 kVA/ton of charge.

Reactance is required in the circuits of an arc furnace to give stability and to limit the current when an electrode makes contact with the metallic charge. The inherent reactance (impedance) in the instance of 10,000-kVa installations and above normally is sufficient. The total stabilizing reactance provided in the case of a 1,000-kVa load normally approximates 30 percent.

Regulation The characteristics of an arc furnace circuit for a given applied voltage are shown in Fig. 7.5.7. For each voltage there is a value of current that gives maximum power in the furnace. This optimum current is the basis of the regulation of the circuit.

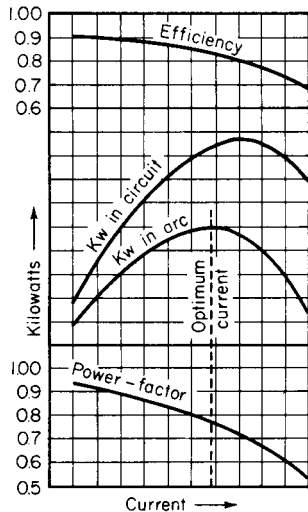

Fig. 7.5.7 Characteristics of an arc furnace circuit.

The control of the power input into direct-arc electric furnaces is effected by the adjustment of the arc length. To accomplish this, the electrode arms are positioned in the "raise" or in the "lower" direction by an automatic regulator. This regulator, which responds within a few cycles, causes the electrode arms to be lowered by extra-fast motor-driven winches when voltage is obtained by closing the circuit breaker. As soon as contact between electrode and scrap charge is established, melting current flows, and this current, whenever excessive, functions immediately through the medium of the winch motor to elevate that particular electrode arm and electrode by the distance corresponding to the diminution in power input needed just at that instant.

Formerly, the so-called contactor regulator was used universally to energize the winch motors. More recently the rotary regulator—this, in effect, being a particularly responsive motor generator set for each of the three phases—has forged to the forefront by reason of giving more precise control with minimized maintenance. Currently, even faster response and electrode-travel speed are provided by low-inertia static-regulating equipment.

Single-Phase Arc Furnaces Single-phase arc furnaces usually are manufactured in the two-electrode type. When the electrodes operate vertically, the furnace melts much as a three-phase direct-arc furnace does. However, most vertical-electrode single-phase furnaces are of laboratory size—that is, up to 150 kVa in powering.

When two electrodes are mounted horizontally in a rocking furnace an indirect-arc unit is obtained. Many rocking furnaces serve well in the melting of brasses, bronzes, and in similar work. Volatiles are reincor-

porated in the metal since the bath washes over much of the interior of a rocking furnace. The oscillation approximates 200°.

Rocking furnaces usually do not exceed 500 kW in powering. A single operating voltage can suffice. In regulating a rocking furnace, only one electrode need be movable, on a carriage under automatic control, to maintain the requisite amperage by varying the length, and therefore the resistance, of the arc gap.

INDUCTION FURNACES

There are two basic types of metal-melting induction furnaces: (1) coreless and (2) core-type. Both types utilize the principle of a transformer. The high-voltage circuit is coupled with that of the low voltage without directly connecting the two circuits. The element responsible for this coupling effect is the magnetic field. Induction heating utilizes the property of the magnetic field, which enables heat to be transferred without direct contact. By correctly disposing the high-voltage winding, which in the case of the induction furnace would be an induction coil or inductor, the magnetic field is directed so that the metal to be heated or melted is made to absorb energy. The temperature attainable is limited solely by the resistance to heat of the surrounding lining material. Induction heating enables any temperature to be achieved while providing for excellent regulation of temperature and metallurgical properties. Any metal which will conduct electric current can be melted in an induction furnace.

Coreless Induction Furnaces (See Fig. 7.5.8.) This type of furnace consists of a crucible, copper coil, and framework on supports arranged for tilting and pouring. The specially designed induction coil acts as the primary of the transformer. The crucible conforms to conventional refractory practice. A rammed crucible is used for furnaces above 50 kW, and preformed crucibles are used on smaller furnaces such as laboratory units.

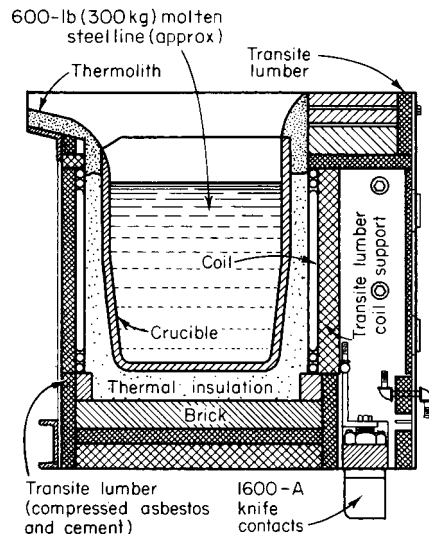

Fig. 7.5.8 Coreless induction furnace.

The principle of operation is essentially the same as that of the induction heater previously described. The initial charge in the furnace is cold scrap metal—pieces of assorted dimensions and shapes and a large percentage of voids. As the power is applied and the heat cycle progresses, the charge changes to a body of molten metal; additional cold metal is added until the molten-metal level is brought to the desired temperature and metallurgical chemistry. The furnace then is tapped.

When the metal in the furnace becomes fluid, depending on whether a line frequency or medium-frequency supply by means of convectors is used, a certain electromagnetic stirring action will occur. This stirring

action is peculiar to the induction furnace and aids in the production of certain types of alloys. The stirring action increases as the frequency is reduced.

Line-frequency applications are generally reserved to furnaces having a metal-holding capacity of 800 lb (360 kg) and above. There is always an ideal relationship between the size of a coreless furnace and its operating frequency. As a general rule, a small furnace gives best results at high to medium frequencies and large furnaces work best at the lower frequencies. A frequency is suited to a given furnace when it yields good, fast melting with a gentle stirring action. Too high or too low frequencies are accompanied by undesirable side effects. The tabulation below gives the charge weights and frequencies generally to be used:

Charge weight, lb	Frequency, Hz
2-50	9,600
12-500	3,000
200-15,000	960
800-75,000	60

The coreless induction furnace is usually charged full and tapped empty, although at line frequencies, it may be necessary to retain a certain amount of metal in the furnace to continue the operation, since it is difficult to start the furnace with small metal particles, such as turnings and borings, in a cold crucible. As a result, it is general practice to retain a heel in the furnace of about one-third its molten-metal volume. This problem can be avoided in furnaces of higher frequencies, where start-up can be performed with small-size metal charges without carrying the heel.

Coreless induction furnaces are particularly attractive for melting charges and alloys of known analysis; in essence, the operation becomes one of metal melting with rapidly absorbed electric heat without disturbing the metallurgical properties of the initial charge.

These furnaces are supplied from a single-phase source. In order to obtain a balanced three-phase input, it is necessary specifically to design the electrical equipment for the inclusion of capacitors and suitable reactors, which are generally automatically switched (by inductance changes) during the operation in order to provide a reasonably high power factor. Power factors on such furnaces can be kept at or near unity. In high-frequency coreless induction furnaces, high power factors are necessary to prevent overburdening the motor-generator equipment.

Core-Type Induction Furnaces (See Fig. 7.5.9.) The transformer is actually wound to conform to a typical transformer design having an iron core and layers of wire acting as a primary circuit. The melting channel acts as a ring short circuit around this transformer in the melting chamber. According to the desired melting capacity, one, two, or three such transformers (or **inductors**, as they are called) may be added to the furnace shell. At all times, the channel must hold sufficient metal to maintain a short circuit around the transformer core. Air cooling is used as required to prevent undue heating of the inductor coils and magnetic cores.

The melting output is controlled by varying the voltage supplied to the inductors with the aid of a variable-voltage transformer connected to the primary circuit of the supply. Core-type furnaces always use line frequencies. Voltage or power-input regulation, therefore, can be performed by adjusting the tap setting of the transformer feeding the furnace transformer attached to the furnace shell. These transformers are single-phase units, and by using three such units, a balanced three-phase input can be obtained. The current flowing through the primary inductors by transformation causes a much larger current in the metal loop, whose resistance creates heat for melting.

The core-type furnace is the most efficient type of induction furnace because its iron core concentrates magnetic flux in the area of the magnetic loop, ensuring maximum power transfer from primary to secondary. Efficiency in the use of power can be as high as 95 to 98 percent.

The essential loop of metal must always be maintained in the core-type furnace. If this loop is allowed to freeze by cooling, extreme care is necessary in remelting because the loop may rupture and disrupt the circuit. This could require extensive work in dismantling the coil and restoring the loop. Consequently, core-type furnaces rarely are permitted to cool. This makes alloy changes difficult because a heel of molten metal always is required.

The relatively narrow melting channels must be kept as clean as possible since a high metal temperature exists in this loop. Nonmetallics or tramps in the charge metal tend to accumulate on the walls in the channel area, restricting the free flow of metal and ultimately closing the passage.

This furnace is particularly useful for melting of nonferrous metals such as aluminum, copper, copper alloys, and zinc.

POWER REQUIREMENTS FOR ELECTRIC FURNACES

The **energy required for melting metals** in electric furnaces varies for a given metal or alloy with the size of the furnace, the thickness of the refractory lining, the temperature of the molten metal, the rate of melt-

Table 7.5.3 Energy Consumption of Electric Furnaces

Process	Type of furnace	lb/kWh
Baking finishes on sheet metal	Batch oven	10-18
Baking finishes on sheet metal	Continuous oven	25-30
Baking bread	Continuous oven	10-12
Annealing brass and copper	Batch furnace	10-25
Annealing steel	Batch furnace	5-15
Hardening steel	Batch furnace	7-11
Tempering steel	Batch furnace	15-25
Annealing glass	Continuous furnace	40-100
Vitreous enameling, single coat	Batch furnace	5-8
Vitreous enameling, single coat	Continuous furnace	10-15
Galvanizing	Batch furnace	12-20

Melting metals	Type of furnace	kWh/ton (2,000 lb)
Lead	Resistor	40-50
Solder 50-50	Resistor	40-50
Tin	Resistor	35-50
Zinc	Induction	80-100
Brass	Arc and induction	250-400
Steel, melting only	Arc and induction	450-700
Steel, melting and refining	Arc	600-750
Gray iron	Arc and induction	450-600

Furnace products	Type of furnace	kWh/ton (2,000 lb)
Aluminum	Electrolytic	22,000-27,000
Calcium carbide	Resistance	3,000-6,000
Ferroalloys	Resistance	4,000-8,000
Graphite	Resistance	3,000-8,000
Phosphoric acid	Resistance	5,000-6,000
Silicon carbide	Resistance	8,500-10,000
Smelting iron ore	Resistance	1,650-2,400

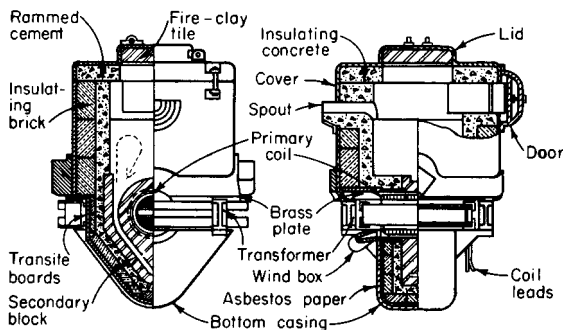

Fig. 7.5.9 Core-type induction furnace.

ing, and with the degree of the continuity of the operation of the furnace. An estimated efficiency of 50 to 60 percent is often used for preliminary purposes. As is well known, 3- to 6-ton direct-arc furnaces often are used to tap acid foundry steels with the consumption of less than 500 kWh to the ton, and large ingot furnaces of this same type, operating basic-lined on common steels for ingots, give even better results despite the call for several more charges of scrap per heat.

Average values in kWh/ton of molten metal are as follows: yellow brass, 200 to 350; red brass, 250 to 400; copper, 250 to 400; lead, 30 to 50; steel melting, when making high-quality double-slag basic heats, 650 to 800 (Table 7.5.3).

Electrode consumption varies considerably in arc furnaces because of their different constructions and operations. Average values in pounds of electrode per ton of molten metal are: steel melting, with graphite electrodes, 5 to 10; brass melting, with graphite electrodes, 3 to 5. Graphite electrodes have largely superseded carbon electrodes.

SUBMERGED-ARC AND RESISTANCE FURNACES

The resistance furnace is essentially a refractory-lined chamber with electrodes—movable or fixed—buried in the charge. This simplicity permits a wide range of designs and much latitude in dimensions. The general service is heating charges of a refractory nature to bring about chemical reactions or changes in the physical structure of the material of the charge. The energy requirement of each of such processes is a large item in the cost of production. Large units and a favorable power location are the rule. Resistance furnaces also are termed submerged-arc furnaces and/or, in quite a few instances, smelting-type furnaces.

The only limit on the temperature to which a charge can be heated by this method is the temperature at which the materials of the charge are vaporized. For temperatures beyond the limit of refractory linings, the materials of the charge are used to form a protective layer between the core of the charge (through which the current passes) and the walls of the furnace.

Resistance furnaces with movable electrodes may be either single-phase or polyphase. The materials of the charge are fed more or less continuously, and the product is discharged intermittently or continuously as required. In some cases the product is in the molten state; in others the product is a vapor. The usual method of operation is the use of a single operating voltage and a constant power input. The power is regulated by adjustment of the depths of the electrodes in the charge. The load is fairly uniform and, if polyphase, is kept reasonably well balanced.

The **resistance furnace with fixed electrodes** is designed for heating ma-

terials in batches and is usually rectangular in shape with an electrode at each end for single-phase operation. The length and cross-sectional area of the path of the current are proportioned to suit the power characteristics of the charge. Refractory materials have negative temperature-resistance coefficients, and hence to maintain constant power in the furnace circuit the applied voltage must be reduced as the temperature of the charge rises in proportion to the square root of the ratio of the initial resistance of the furnace circuit to the resistance of the furnace circuit at the end of the heat cycle. If the materials of the charge are nonconductors at room temperature, a starting circuit is provided by means of a core of carbon—usually coke—placed in the charge. The heat cycles of furnaces of this class generally extend over a period of several days.

Some of the more common **uses of the resistance furnace** are:

Calcium carbide furnaces are charged continuously with lime and coke. These equipments can be either open or closed top. This type of furnace has been built up to 70,000 kVA in electrical powering—covered and sealed for gas collection.

Ferrous alloy furnaces for the production of ferrochrome, ferrosilicon, ferromanganese, etc., are usually three-phase furnaces with movable electrodes and are similar in construction to the three-phase arc furnace. The charge is a mixture of the ore (oxide) of the selected metal, scrap iron, and a reducing agent, generally carbon except for very low carbon content alloys, for which some other reducing agent such as aluminum or silicon is required. Six-electrode furnaces often are used for power inputs of 15,000 kVA and more.

The **graphitizing furnace** is of the single-phase batch type. Artificial graphite is made by heating amorphous carbon (coal or coke) while shielded from air to a high temperature—around 4,500°F (2,500°C). The presence of some metallic impurity, such as iron oxide, in the charge appears to be necessary for the conversion of amorphous carbon to graphitic carbon. The raw material for making bulk graphite constitutes both the charge and the protective layer around the core of the charge. Graphite shapes are made from the corresponding shapes of amorphous carbon which are embedded—between the electrodes—in raw material as noted for the manufacture of bulk graphite.

The **silicon carbide furnace** is similar to the graphitizing furnace. The charge is a mixture of sand (silica), coke, sawdust, and a small amount of salt. This mixture is packed around a core of granulated coke to form the initial circuit between the electrodes. The sand and coke are the reacting materials. The sawdust serves to make the charge porous so that the gases formed during the heating of the charge can escape freely. The salt vaporizes and removes impurities, such as iron, in the form of chlorides. The temperature of the process is 2,700 to 3,400°F (1,500 to 1,880°C).