



Ethanol vehicle

# EYA Biomass Vehicle

## Building the 'Stirly, the Little Engine that CAN'

### INTRODUCTION

Stirly was designed as an educational model to demonstrate how biomass fuels (clean and renewable fuels made from plant materials) can be used to power vehicles. It is meant to inspire people into thinking about alternatives to fossil fuel energy. It is also meant to promote a very exciting and promising sustainable technology for not only locomotion, but also heating, cooling, and power generation, namely, the Stirling engine.

### THE STIRLING ENGINE

The Stirling engine, invented in 1816 by Rev. Robert Stirling, is one of the most efficient, quiet, non-polluting, and versatile engines ever invented.<sup>1</sup> It can run on virtually any fuel, including natural gas, propane, diesel, gasoline, crude oil, flare gas, solar, geothermal, biomass, hydrogen, landfill gas and waste heat.<sup>2</sup> This wide variety of suitable fuels ensures that energy from Stirling engines can be produced both locally and sustainably.

### HOW A STIRLING ENGINE WORKS

A Stirling engine is an external combustion engine, or a heat engine. In contrast to traditional internal combustion engines that we see in automobiles, which take in fuel and air, a Stirling engine works differently. It doesn't take in any fuel or air. Instead, a Stirling engine contains a sealed-in amount of gas (usually pressurized helium or hydrogen) that is used over and over to power itself. Rather than burning fuel inside, a Stirling engine uses external heat to expand its contained gas and push against its pistons. The engine then recycles the same captive gas by cooling and compressing it, then re-heating it again to expand and work the pistons. (For a detailed explanation of how a Stirling engine works, see Sources section.)

### STIRLY'S TIN CAN STIRLING ENGINE

Stirly uses a very simplified Stirling

engine made from a few parts that can be found at most hobby shops and hardware stores. Its working gas is simply air, sealed in a tin can with the use of a rubber balloon on top. Its fuel source is isopropyl alcohol (rubbing alcohol) – a biomass fuel.

Stirly's design was inspired by Mr. Saburo Tsucchida's tin can Stirling engine design plans. [See Sources section] Stirly was designed and built by Eesmyal Santos-Brault, an employee of the Environmental Youth Alliance [EYA], Vancouver, BC.

### **Materials needed:**

- plastic sheet (Plexiglas, lexan, or Lucite) – 3/16" thick [hardware store]
- tin can – preferably without ribs along sides
  - about 6.5 cm diameter, 10cm tall
  - the perfect can we found was no name brand "Pieces & Stems Mushrooms", 284ml (10fl oz), found at corner store on Hastings at Abbott, Vancouver.
- balsa wood - 1 cm thick (300

- cm<sup>2</sup> min. area) [hobby shop]
- 3/4" (about 2cm) thick piece of wood (about 2 x 6 x 9.5cm) – see Fig. 3
- wooden dowel – about 6mm diameter [hobby shop]
- 16 gauge floral stem wire, or other such wire that's bendable, yet holds its shape – at least 30cm long (buy a few of them 'cause you'll probably wreck 2 or 3 before you get it right)
- 9" balloons (you need a few, in case of mistakes and for replacement)
- plasticine [art supplies store/hobby shop]
- hollow plastic tube – 1/2" outside diameter; 1/8" inside diameter; at least 30cm long
- "All Round" steel strapping – 1/2" [hardware store]
- very small glass bead – ensure the hole is just barely large enough to let the fishing thread smoothly pass through it [art supplies store]
- fishing thread – 20cm min.
- 4 wheels – dimensions? (find order booklet)

- 2 pulleys -dimensions? (find order booklet)
- about 20 cm of thin copper wire
- hose clamp – large enough to tighten around can
- fondue burner (about 9cm wide and 4 cm tall) [kitchen supply store]
- 99% isopropyl alcohol (biomass fuel-is it truly?) [pharmacy store]
- wide rubber band – large enough to tightly fit around can
- the rubber elastics from 2, cheap dust masks
- paper clip
- 2 thumbtacks
- 8 round-head wood screws – about 9/64” diameter and 2cm long
- 4 bolts & nuts – between 5/32” and 11/64” diameter, and about 1 cm in length
- plain wood glue or balsa wood glue
- duct tape and/or ‘Superglue’
- sewing pin or safety pin – small enough to pass through the glass bead
- fine-point marker and pencil

- cotton swab

[Fig 1: Detailed Front View of Stirly]

**Tools Needed:**

- 2 1/2 “ hole saw
- power drill
- imperial drill bit set
- scissors
- Plexiglas knife, or exacto-knife
- can opener
- needle nose pliers
- regular pliers
- hot glue gun + glue stick
- hand saw
- vice
- file, or medium sandpaper
- work gloves and safety goggles
- large drafting triangles
- metric and imperial ruler(s) – metal, if possible
- work bench
- 2 – 3 small C-clamps
- awl or center punch – tool for making indentations
- multi-bit screw driver
- tin snippers – for cutting thin metal
- BBQ lighter

NOTE: Read over all instructions as well as safety tips before building.

### Step 1: Cut Out Triangle Frames

Using drafting triangles and ruler, mark the plastic sheet as follows (without yet removing the protective paper covering):

[Fig 2: Plastic Frame Dimensions]

Use the awl or center punch to make indentations at all hole centers on only ONE of the triangles. Place the plastic sheet onto a workbench and clamp it down with some C-clamps. Using the Plexiglas knife, or exacto-knife, as well as a ruler to guide the knife, and protective gloves, carefully carve a deep groove along the sides of the triangle shapes. (Remember to NEVER pull the knife directly towards your body.) You'll probably have to go over the lines a few times before a sufficient groove is made.

Remove the C-clamps and flip the plastic sheet over. By gently bending the sheet upward against the grooves, the sheet should easily snap only along the grooves. If it doesn't easily snap, flip it over and cut it some more, and then try again.

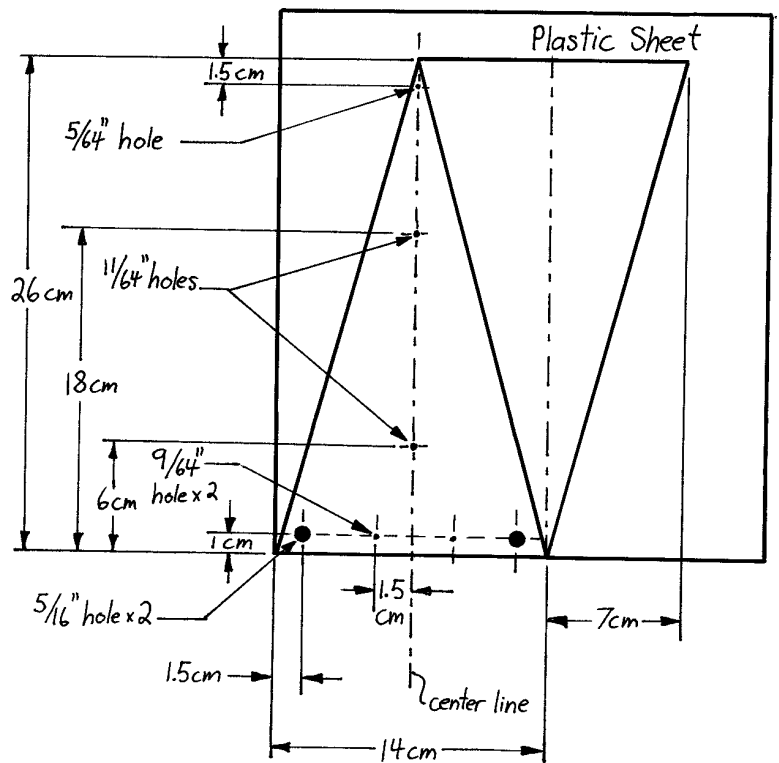

### Step 2: Drilling Holes into the Frames

Remove the protective covering and place the plastic triangles on top of one another, with the one with indentations in it at the bottom. Line the triangles up with one another and clamp them down to the workbench, making sure not cover any of the indentations with the C-clamps.

Now make indentations on the top triangle that line up exactly with the ones below.

(These indentations are for guiding the drill so that it doesn't go awry.) Using the appropriate drill bit sizes, drill the holes through both sheets. For the larger holes, start with making small

holes and gradually increase them in size. This ensures the plastic doesn't crack because of removing too much material at once. If either plastic triangle starts to slide in the very slightest when drilling commences, STOP drilling. Re-align the triangles, clamp them down harder than before and start again. Remove any dangling bits of plastic with the file or sandpaper.

### Step 3: Make Wooden Base

Start with a  $3/4$ " (about 2cm) thick piece of wood and cut it to the following dimensions:

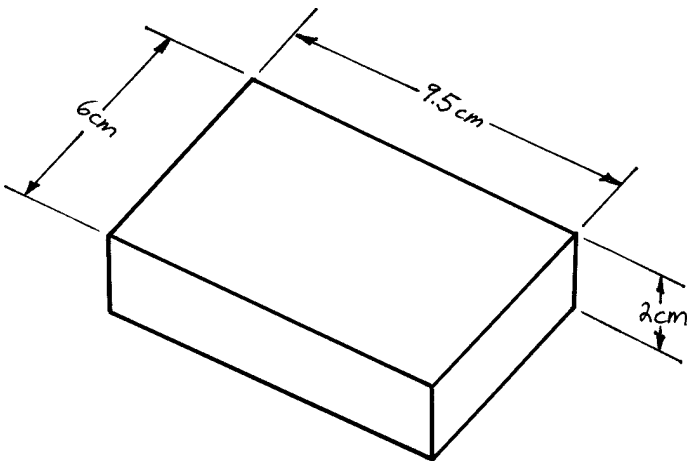

[Fig 3: Wooden Base]

When finished, place the wood onto a flat surface, face down. Take one of the plastic triangle frames and stand it

up against the 6cm side of the wooden base.

Try to center the wooden base in the middle of the plastic triangle frame and hold firmly in place. It might help to have someone else give you a hand. Poke a fine-point marker through the two middle holes of the plastic frame onto the wooden base, to mark where you will be putting the screws into.

### Step 4: Attaching the Frames to the Base

Now put the wooden base into a vice, with the marked side up. Use the awl or center punch to make small indentations at the marked spots. Using a  $3/32$ " drill bit, drill slowly down into the wooden base at the two marked spots, ensuring the drill bit is as vertical as possible. Drill only about 2cm down – about as long as the length of the wood screws. The purpose of making these holes is so that when the wood screws are screwed in, they don't cause the wood to crack.

Now attach one of the plastic frames to the base with the wood screws.

Remove from the vice and place the attached items onto a flat surface. Line up the other plastic frame onto the other side of the wooden base. With the help of some extra hands, slide one of the floral stem wires in through the top two holes. Fiddle with the position of the unattached plastic frame until the wire is lined up perpendicularly to both the plastic frames and the wire can spin freely when rotated.

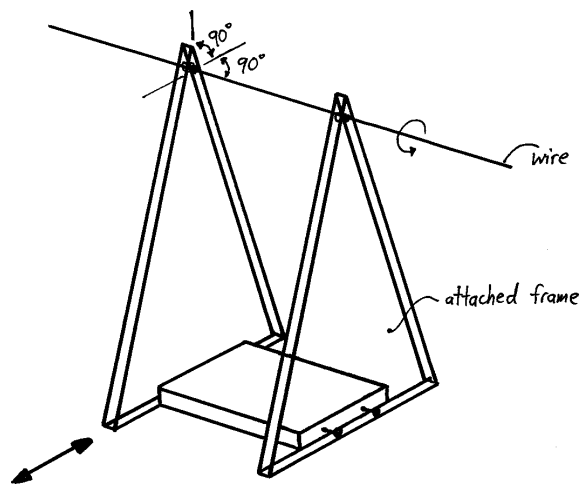

[Fig 4: Aligning the Plastic Frames]

Mark where the second set of screw holes will go and then unscrew the attached plastic frame and remove the metal rod. Using a sharp pointed object, etch the inside face of one plastic frame (where the wooden base touches) with the letter “A” and the other with the letter “B”. Now mark (in

pencil) on the wooden base sides, “A” and “B”, respectively. This is so that whenever you have to take Stirly apart, which may happen a lot in the beginning, you don’t get the parts and positions mixed up.

Repeat the procedures above for attaching the second plastic frame.

### **Step 5: Make Balsa Wood Displacer Piston**

[Function: to ‘displace’, or move, the air back and forth between the hot end of the can, where it expands, to the cool end, where it contracts]

Attach the 2 1/2” hole saw to the end of the power drill and drill out 5 disks of balsa wood. Use some sandpaper to clean up any rough edges on the disks. Using plain wood glue or balsa wood glue, glue the disks together in a neat stack and let it dry for about an hour.

When dry, stuff the center hole at one end with a little bit of plasticine and tape it shut with a piece of duct tape. This end will be the bottom end of the displacer piston – the hot end.

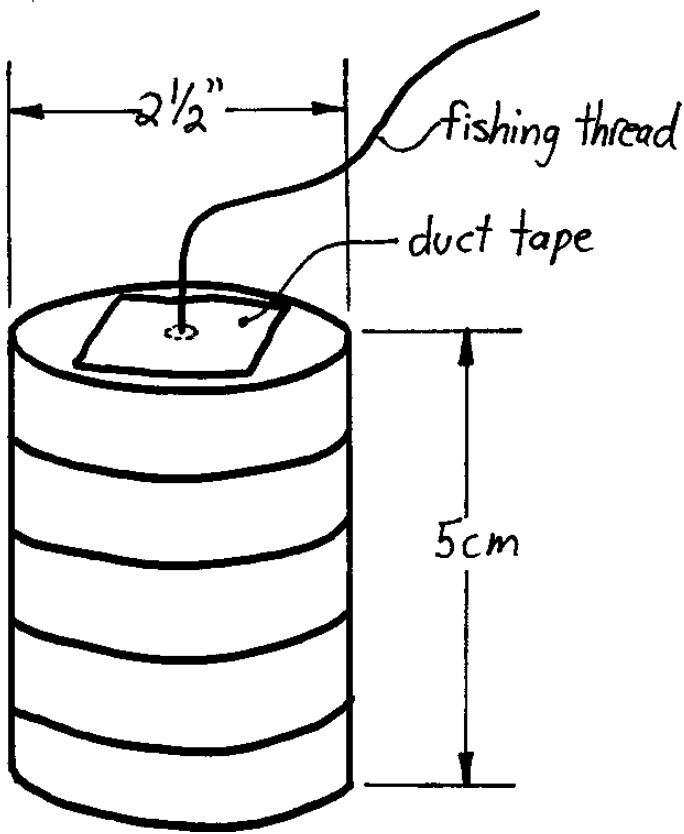

[Fig 5: Displacer Piston]

Tie one end of a 20cm length of fishing thread to a small balled up piece of tissue paper, large enough to fit tightly into the top center hole of the balsa wood stack. Cover the tissue paper ball with glue and stuff into the top hole so that the fishing thread is in the very center of the cylinder and is aligned vertically. You may need to prop up the fishing thread with something while the glue dries. Let it dry for about an hour.

Make a small hole through the center of a 5cm x 5cm piece of duct tape.

Run the loose end of the fishing thread up through the hole (sticky side first) and slide the tape down onto the top of the balsa wood cylinder.

### Step 6: Make the Connecting Rods

[Function: to transfer the forces of the expanding and contracting balloon to the crankshaft]

Measure and cut off two 8cm lengths of wooden dowel. Put one gently into the vice in a horizontal position and make a mark 1cm from its free end. Using the awl or center punch, make an indentation at the 1cm mark, right in the middle of the rod. Drill a hole through the indentation using the 5/64" drill bit, making sure that the drill bit goes directly through the middle of the rod and at right angles to it. Repeat this for the other connecting rod.

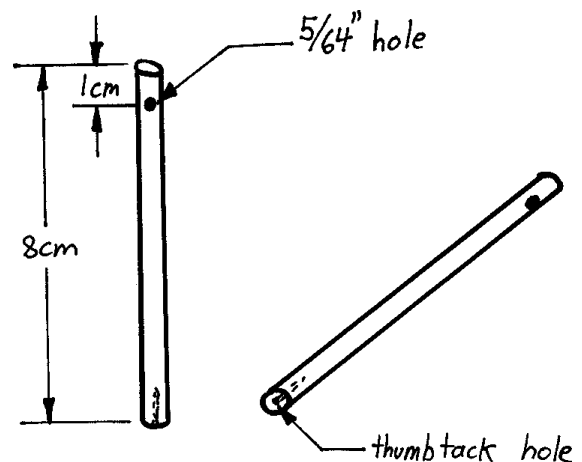

[Fig 6: Connecting Rods]



Push a thumbtack into the center of the ends of each connecting rod – the end opposite of the hole. Drive it in all the way. You may have to put the rods into the vice and gently hammer the tacks in. Now remove the tacks.

**Step 7: Make the Crank Shaft**

[Function: to transfer the up and down forces of the connecting rods to the flywheel. The connecting rods and crankshaft together form a simple linkage system that translates the up and down motion of the balloon into circular motion to spin the flywheel.]

This is probably the most difficult part to make. When bending the wire, try as much as possible to make sharp, 90 degree bends. As well, ensure each section of wire between bends is completely straight.

Start in the middle of piece of floral stem wire and grip it with a pair of regular square-edge pliers. Now bend it over the edge of the pliers into the following shape with these dimensions:

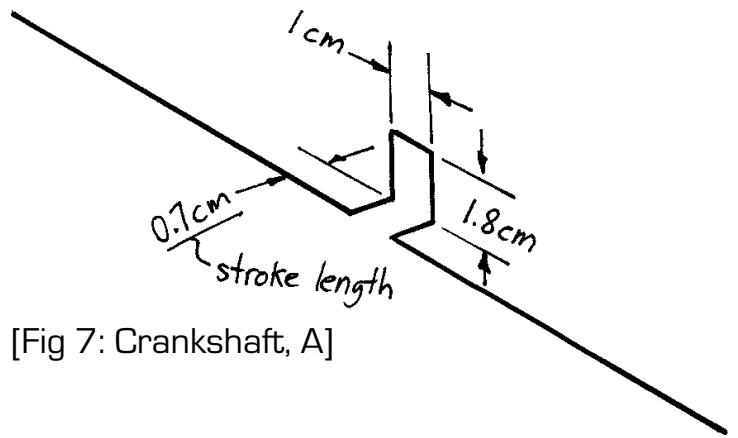

[Fig 7: Crankshaft, A]

Slide each connecting rod onto either side of the wire.

Using the very tip of a pair of needle-nose pliers, grip the wire tightly against one connecting rod like figure 8.

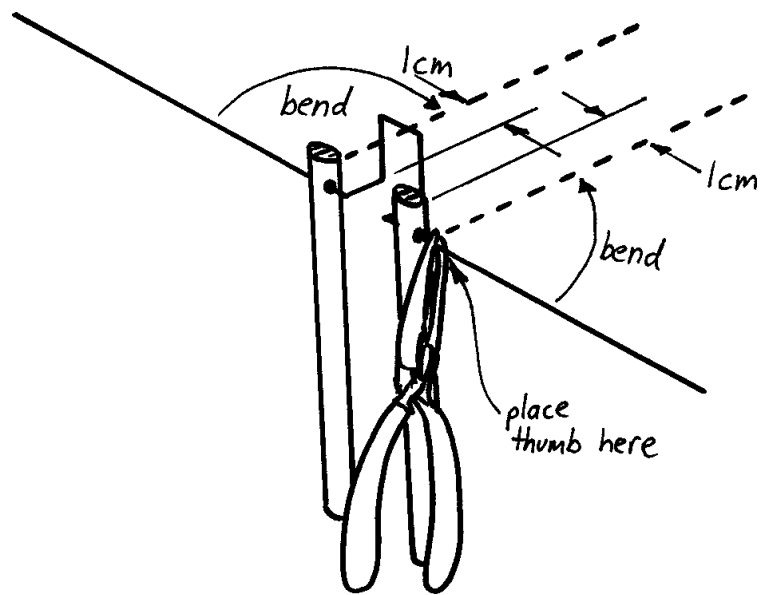

[Fig 8: Crankshaft, B]

Then position your free thumb as close as possible to the contact point between the wire and the pliers. Bend the wire over the tip of the pliers using your thumb so that the wire looks like this:

Hold the wire in one hand and try to give the newly secured connecting rod a spin. It should spin freely. If it doesn't, chances are that the section of the wire going through the rod isn't completely straight. If this is the case, try to bend it straight. If the rod still doesn't spin freely, you may have to try again with a new piece of wire. Be patient.

Repeat the above procedure for the other side. Then bend the ends so that the wire looks like Figure 9.

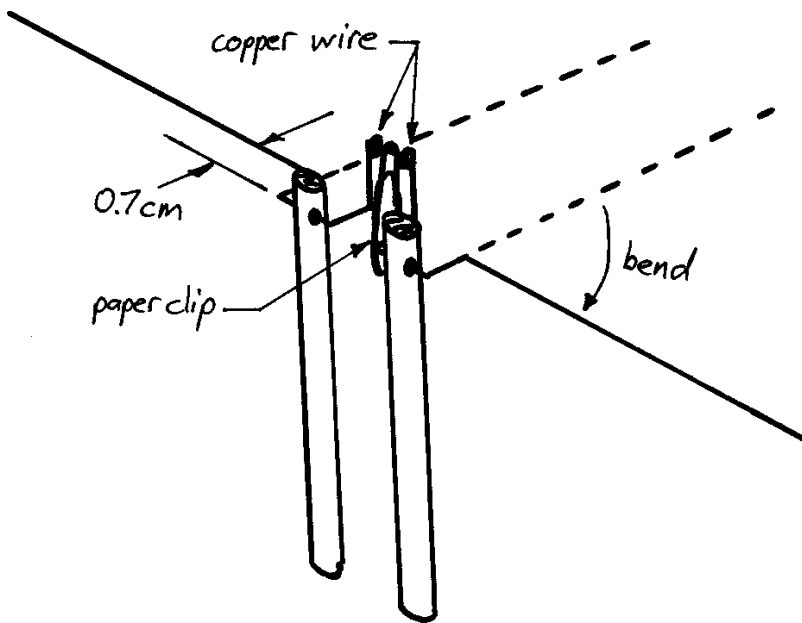

[Fig 9: Crankshaft, C]

Connect a paper clip to the center of

the crankshaft. Now, tightly wrap some thin copper wire (about 5 loops) on either side of the paper clip. Make sure the paper clip can freely spin about the crankshaft.

### Step 8: Make the Power 'Piston' (Balloon Diaphragm)

[Function: to transfer the pressure forces of the expanding and contracting air to the connecting rods]

Lay one of the 9" balloons flat and cut it here:

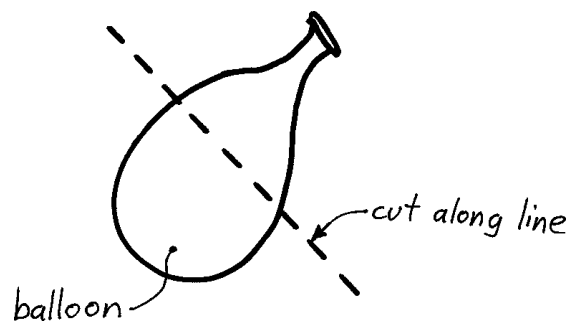

[Fig 10: Cut Balloon]

Remove one end of a 284ml (6.5cm x 10 cm) can and empty, clean, and dry it. Wrap the balloon section over the open end of the can and position it so that the very bottom end (usually has a visible bump on it) is at the center of the can. Ensure that the surface area of the balloon that's over the can is

completely flat by pulling the balloon down tightly.

Now wrap an elastic band tightly over the can, onto the balloon, so that the balloon stays securely in place. Dip a cotton swab in a bit of isopropyl alcohol and clean the surface of the balloon. Use a marker to mark the center bump of the balloon.

Next, hold your crank shaft and connecting rod assembly over the top of the can and let the connecting rods naturally hang down. Position the assembly so that the center point between the rods is just above the center point of the can. Use a fine-point marker to mark on the balloon (along the diameter of the can) exactly where the center of each rod naturally falls.

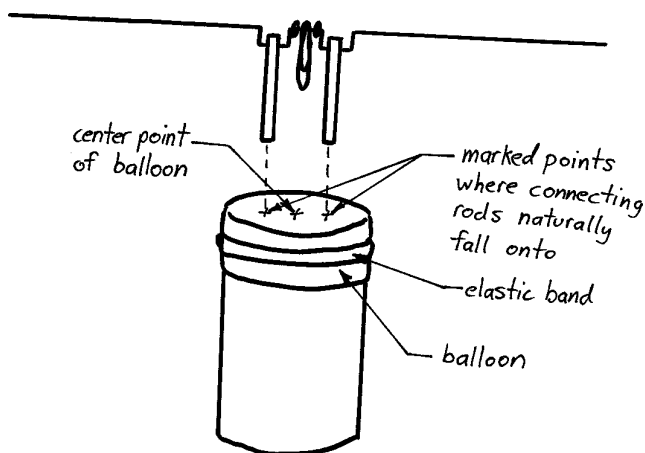

[Fig 11:]

You'll need an extra person for this part. Using the needle-nose pliers, have one person hold a small glass bead (hole side vertical) directly onto the center of the balloon. Then, using the hot glue gun, some else can carefully glue the bead in place, trying not to get glue in the bead's hole. Apply glue around the bead, as opposed to directly under it. Let cool for 10 min.

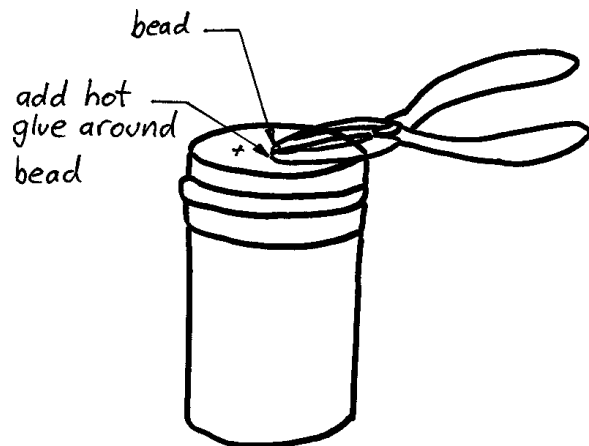

[Fig 12]

When dry, apply a thin layer of hot glue on the surface of the balloon that extends out radially from the bead to where the marked points are. Make sure that this thin layer is physically connected (bonded) to the glue around the bead by re-melting the point where they both meet. Let cool for 10 min.

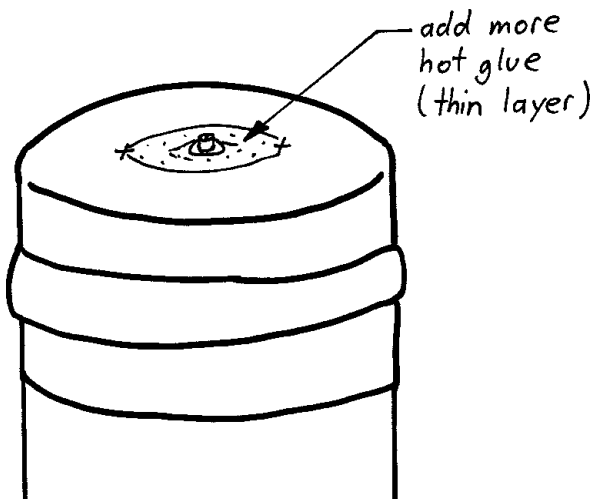

[Fig 13]

When dry, hold a sewing needle or safety pin with a pair of pliers and heat its free end (pointy end) with a lighter for about 5-10 seconds. Then poke the needle through the bead (to puncture the balloon and melt any glue that may be in the way) and then immediately remove it.

**Step 9: Make Tin Can Supports**

Use the tin snips to cut two 16cm lengths (11 holes) of "All Round" steel strapping - 1/2". Use pliers to bend each one into the following shape:

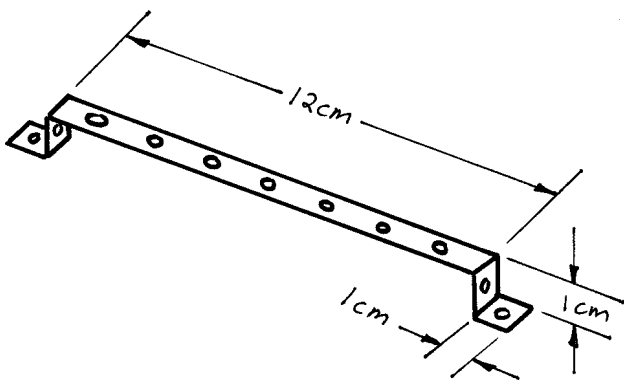

[Fig 14]

Using the bolts & nuts from the materials list, attach the steel strapping to the plastic frames, as in Figure 1.

**Step 10: Adjusting the Position of the Tin Can**

Take off one of the plastic frames and fit the crankshaft into place. Replace the plastic frame.

Loosely connect the can between the supports with the hose clamp. Rotate the crankshaft so that the middle part (with the copper wire on it) is aligned vertically. Hold it there. Now slide the can up or down so that the connecting rods are just touching the balloon's surface. Use a marker to mark on the steel strapping the position where the bottom edge of the can touches the strapping.

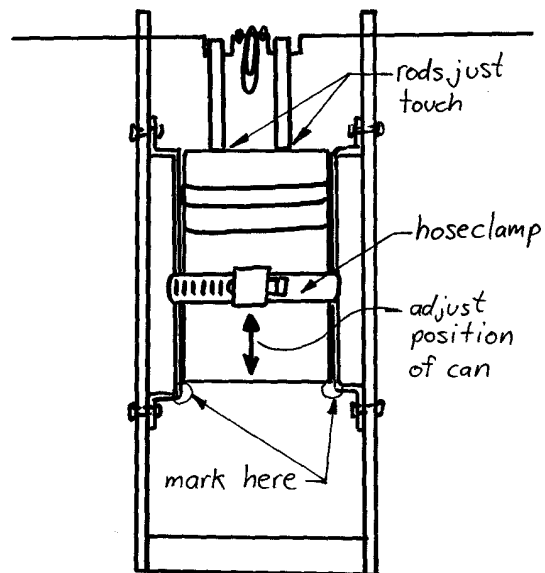

[Fig 15]

### Step 11: Attach the Connecting Rods to the Balloon

Remove the crankshaft and the can and take off the balloon. Poke thumbtacks through the marked points on the balloon – so that the points are coming out of the glued side. Now securely connect the thumbtacks to the connecting rods (with the balloon in between).

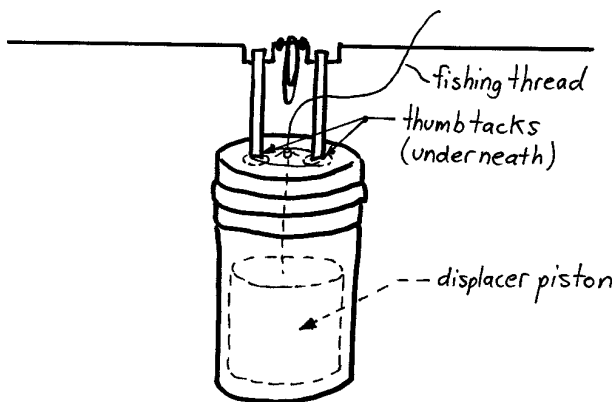

[Fig 16]

You'll need an extra person for this part.

Put the balsa wood cylinder (displacer piston) into the can. Feed the fishing thread through the bottom side of the balloon and replace the balloon tightly onto the can with the elastic. Make sure the balloon's surface is flat.

Replace the crankshaft into the plastic frames and reposition the can to the

steel strapping. Center the crankshaft and then wrap a 1 cm wide strip of duct tape tightly around one end, about 3mm away from the plastic frame. Wrap it about 3 times, enough so that the small pulley can be securely fastened over it. (You could also try a bit of super glue to fasten the pulley.)

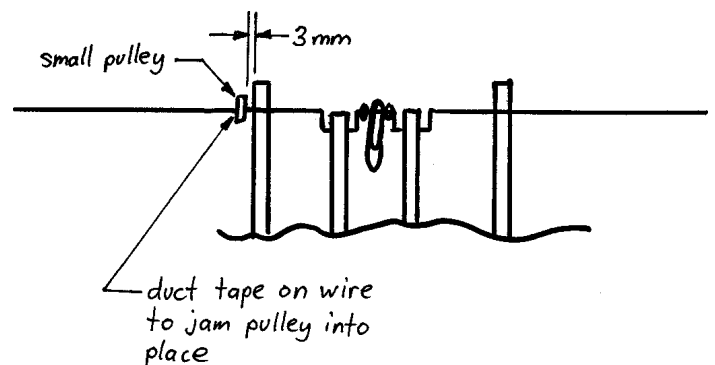

[Fig 17]

Use pliers to bend the ends of the crankshaft into the following shape:

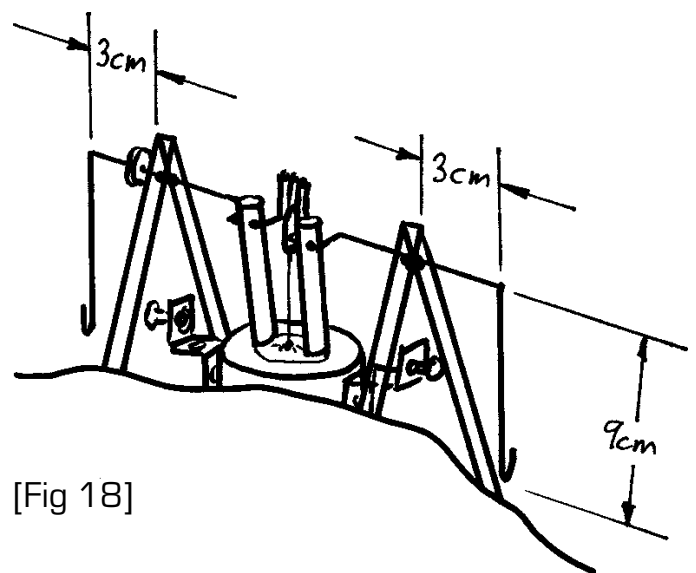

[Fig 18]

Tie the fishing thread to the paper clip at the point where when the crankshaft is turned a full revolution, the displacer piston touches neither the bottom nor the top of the can.

### **Step 12: Add the Flywheel**

[Function: to give the crankshaft momentum, in order to keep the displacer piston moving up and down]

Make two balls of plasticine, about 2.5cm in diameter and stick them securely onto the ends of the crankshaft.

### **Step 13: Make Axles and Add Wheels**

Measure the width of your Stirly and cut a length of hollow plastic tube that's just 2-3mm longer. Cut another length of tubing that's about 15mm longer. Make sure the cuts are smooth and completely perpendicular to the length of the tubing. Gently place each piece of tubing vertically in a vice and screw in the wood screws into each end. This serves to thread the tubing so that it's easy to put the wheel on and take them off.

Using C-clamps, or a monkey wrench, secure one of the plastic wheels and drill through its center with a  $\frac{1}{8}$ " drill bit. Fit the wheel onto the end of the longer plastic tube so that when the tube is put through the plastic frames, the other side of the tube only sticks out about 2-3mm past the frame.

Put the other tube through the frames and screw on all four wheels.

### **Step 14: Make the Elastic Band**

Cut the elastics off of two dusk masks and tie them together end to end. Loop the elastic around each pulley and tie the ends together so that there is enough tension to make the bottom pulley turn when the crankshaft is turned. Cut the loose ends.

Congratulations! You've finished. Now, to test it out...

### **Step 15: See if Your Stirly CAN Run!**

NOTE: read safety tips before doing this.

Fill the fondue burner about  $\frac{1}{2}$  full with 99% isopropyl alcohol (rubbing alcohol) and place on top of the wooden base, under the can. Ignite the alcohol using

a BBQ lighter and let it heat the can for about 10-15 seconds. Then give the crankshaft a light spin in the direction that causes the connecting rods to first move upward. (The crankshaft can only spin in one direction.) Put out the flame by simply replacing the lid over the fondue burner.

Does it work? If not, the problem could be too much friction between the moving parts and/or the air in the can may not be sealed in well enough. Also, you may want to try adjusting the weight of the plasticine balls. Check these points.

## **Tips to reduce friction**

- put motor oil at the points where the wheel axles and the crank shaft touch the plastic frames
- if the fishing thread rubs the glass bead too much, you may have to put a few drops of motor oil in the bead; or perhaps your bead is just too small

## **Safety**

- only operate on smooth, non-flammable surface
- have fire extinguisher on hand in case of fire
- if strong smell of melting plastic, immediately put out flame and let stand for 5 min
- don't let run for more than 2min with large flame, or balloon may start to melt
- when operating any power tools, always wear safety goggles, gloves; tie hair back and avoid wearing loose clothing. Also, try to get into habit of disconnecting power source, when power tools aren't in operation

## **Experiment!**

Try varying the dimensions of a few parts, like stroke length, fishing thread length, pulley sizes, displacer thickness, flywheel weights, etc, to see what happens. Improve/modify this model!!!

## Sources

**EYA would like to acknowledge the original sterling engine designer Mr. Saburo Tsucchida's website**

<http://www.bekkoame.ne.jp/~khirata/>

### **How a Stirling engine works**

[http://sesusa.hypermart.net/stir\\_au.htm](http://sesusa.hypermart.net/stir_au.htm)

<http://www.bekkoame.ne.jp/~khirata/english/howwork.htm>

<http://www.grc.nasa.gov/WWW/tmsb/stirling.html>

### **Other models and good info**

<http://www.stirlingengine.com/>

### **Bibliography**

- <sup>1</sup> Senfet, James R. An Introduction to Stirling Engines, Moriya Press, River Falls, 1993
- <sup>2</sup> Ross, Andy Stirling Cycle Engines, Solar Engines, Wellsville, 1981