CHAPTER 2

FISHING GEAR AND EQUIPMENT

A.	THE STANDARD BOTTOM-FISHING RIG	14
B.	LINE MATERIALS	15
C.	HOOKS, SWIVELS AND SINKERS	16
D.	TOOLS AND UTENSILS	18
E.	KNOTS FOR HOOKS AND TACKLE	20
F.	KNOTS FOR JOINING LINES	22
G.	USING LOOPS TO JOIN LINES AND ATTACH TACKLE	23
H.	END LOOPS IN CABLE	24
I.	TRACE ATTACHMENT POINTS	26
J.	THE ASSEMBLED LINE	27
K.	REELS FOR BOTTOM FISHING	28
L.	BAIT	30
M.	CHUM	32

SECTION 2A: THE STANDARD BOTTOM-FISHING RIG

Deep-bottom fishing gear can be made from a range of materials, but the basic structure is generally the same:

- a **mainline**, several hundred metres long, to lower the hooks to the bottom. For reasons of cost most fishermen use nylon for the mainline, but some prefer a braided line (such as ‘Super-Toto’), which stretches less and allows the fisherman to feel the bite more easily.
- a **terminal rig**, usually 2–5 m in length, with attachment points for the mainline, several hooks, and a sinker. The terminal rig may be made of nylon, or steel cable to resist cutting by the sharp teeth of fish or rough rocks and corals on the sea floor. The attachment points may be loops made on the ends of the terminal rig and at intervals along its length, or may be swivels knotted or crimped into the rig.
- several **hooks**, each fixed to a short **trace** which can be connected to or disconnected from the attachment points along the terminal rig. This allows the traces to be changed quickly and easily when damaged or when the size of the fish being caught calls for smaller or larger hooks.
- a heavy **sinker**, 0.5–2 kg in weight depending on the strength of the current, to get the rig down to the bottom quickly.

In some cases, the terminal rig may also carry a **chum-bag** (see section 2M). This is attached to a short trace so that it can be connected to the upper hook attachment point, or to the swivel that connects the terminal rig to the mainline.

Because the fishing grounds are outside the reef, deep-bottom fishing is always carried out from a boat. This may be anything from a small canoe to a large commercial fishing vessel, but in most cases artisanal fishing boats of 6–12 m in length are used. The gear may be fished by hand or using one of the fishing reels described in section 2K.

Chapter 3 provides more information on preparing deep-bottom fishing vessels, while the rest of this chapter focusses on the fishing gear itself.

Bottom fishing from a small (8m) fishing vessel

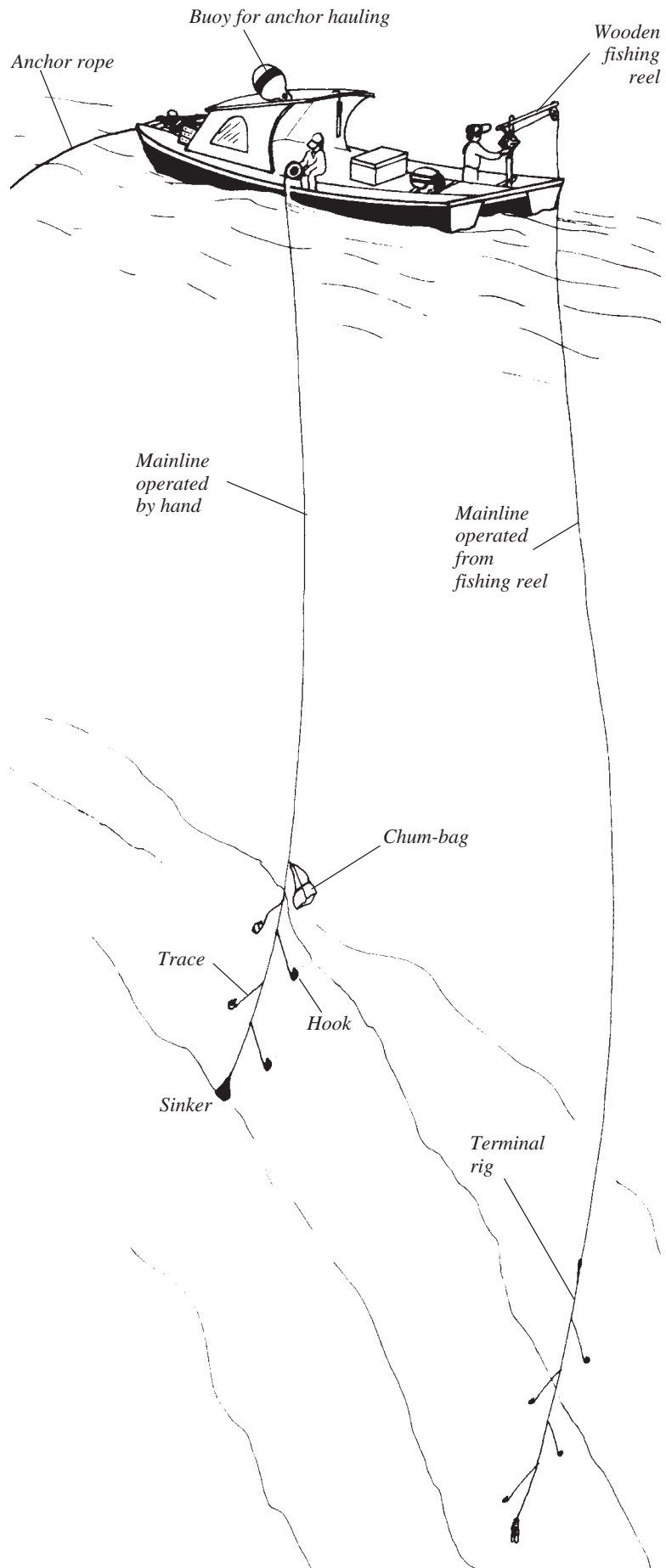

SECTION 2B: LINE MATERIALS

Various monofilament and multifilament fishing lines are available in a variety of materials, including natural fibres, plastics and other synthetic fibres, and metals. The main types of line are:

- **monofilament**; single filament plastic lines, usually nylon
- **multifilament**; lines made of several or many threads
- **twine, cord** and **rope**: line of increasing weight in which two or three bundles of fibres are twisted together
- **braidline**: line of several filaments woven together; often as a sleeve around a central core of fibres
- **cable** (also called multi-strand wire): metal lines made of several filaments (wires) twisted together

The main types of line used in bottom fishing are nylon monofilament or braided lines such as super-toto, which are used for the mainline. Typical line strengths would be 20–50 kg breaking strain in shallow waters, and 50–100 kg in waters deeper than 100 m. Terminal rigs and traces are generally made of monofilament nylon or steel cable. Single-strand wire is not generally used in deep-bottom fishing, due to the tendency of the fish to spin on the line when hauled in, causing the wire to snap.

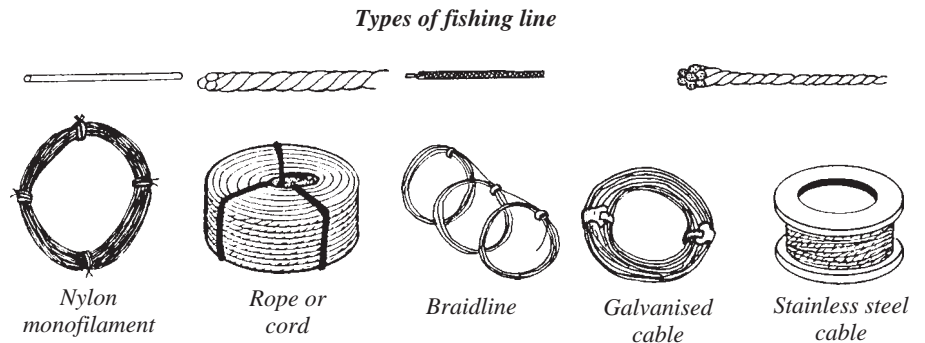

Handling lines

A line is in its natural state when it is laid out straight and under slight tension. At other times, such as when coiled, or faked on deck, careful handling is required to avoid tangles, kinks and knots which will diminish its performance. In particular:

Don't allow cable to get twisted, curled or kinked by bad storage and handling. This can easily result in line breakage.

Don't allow unnecessary knots to develop in lines. Knots can weaken a line to 50 per cent or less of its original strength. If a line gets knotted, discard it or cut out the knot and rejoin the line. Never pull tangled lines tight if you can avoid it.

Don't expose lines unnecessarily to the weather. Sunlight causes deterioration in synthetic lines; water and bacterial growth rot natural fibres; salt water rusts wires and cables. Leave new lines on shore until they are needed.

Do check lines regularly for condition. Look for surface abrasions, cuts, flattening of the line, wear, fraying, rusting, knots, and oil contamination. Decide whether the wear point has been significantly weakened. If so, repair or replace it.

Remember: a weakened line will break at the time when it is under the greatest strain—with a big fish on the end of it.

Sections 2E–2I provide information on working with various types of ropes, lines and cables and describe the knots and fastenings needed to rig bottom fishing gear.

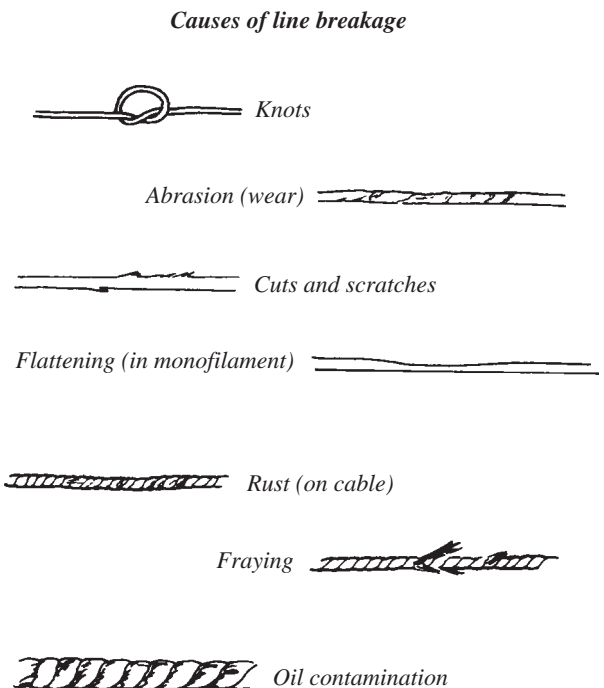

SECTION 2C: HOOKS, SWIVELS AND SINKERS

Functions of a hook

The hook has two functions — to catch the fish, and then to retain it until it is safely on board the boat. To catch the fish, the hook has to be of the right shape so that the point will catch in the fish's mouth, gills or stomach. The point has to be hard enough and sharp enough to penetrate through hard skin and bone. The shank and the bend of the hook have to be solid and strong enough to take the impact of the striking fish, and its struggles to break free, without snapping or straightening.

As well as being strong and sharp, a good hook should be rust-resistant for long life, and smooth, so as not to act as a saw and cut its way out of the fish. Hooks are sold in a wide variety of shapes and sizes. Single, double and even treble hooks are used in various forms of fishing but for deep-bottom fishing the preferred type is a curved single hook.

Parts of a hook

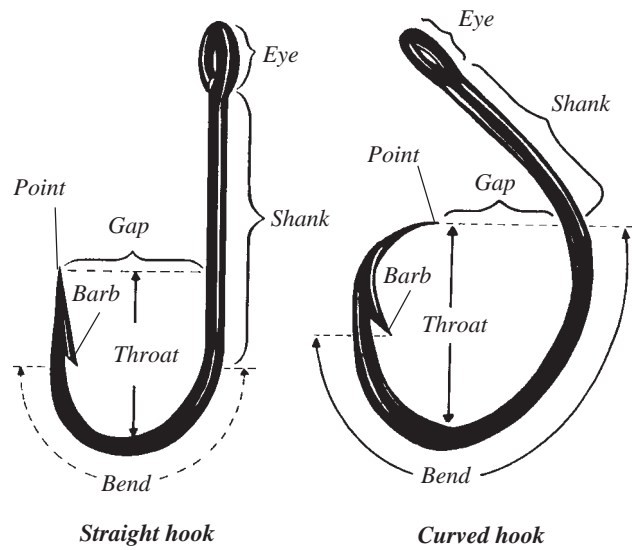

Hook action

The actions of straight and curved hooks differ as follows:

- with a straight hook, if the fish feels the point and pulls back, the hook will often pull out. Straight hooks are good for the types of fishing in which the bait is moving, such as trolling, or styles of fishing in which the fisherman can strike and deliberately hook the fish, such as rod-fishing or shallow-water handlining. In deep-bottom fishing, however, it is hard to strike effectively, so unless the fish actually swallows the bait, it may not be caught on a straight hook.

Action of a straight hook

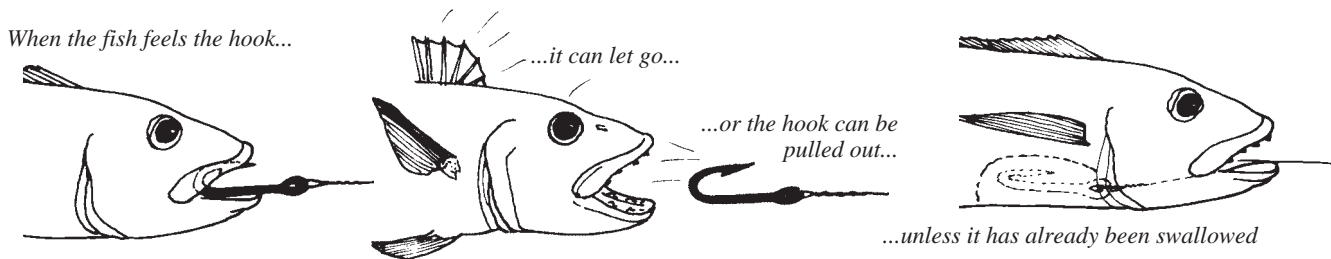

- with a curved hook, if the fish feels the point and pulls back, the hook will rotate and catch around the corner of the mouth. The hook is essentially 'self-hooking', which is advantageous for fishing in deep water, where it is hard to feel the bite, and where the length and elasticity of the line make it difficult to strike quickly.

Action of a curved hook

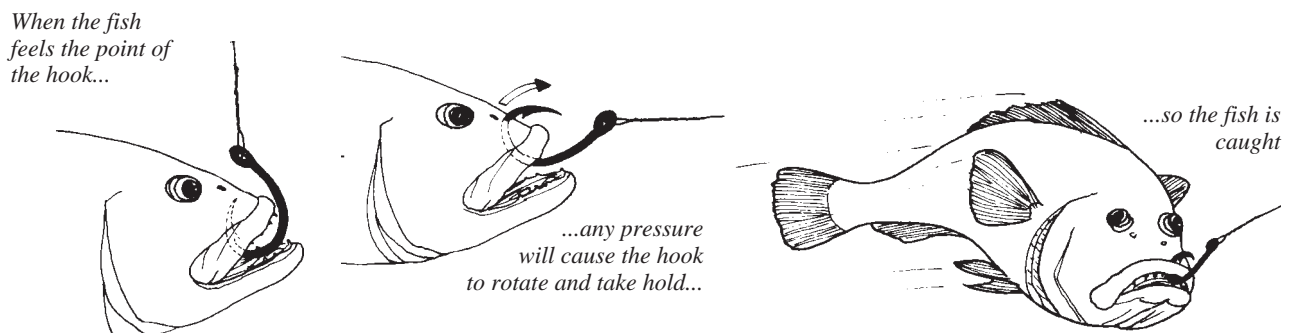

Hook types

There are various kinds of curved or circle-type hooks, as shown below. The type most commonly used is the Mustad Tuna Circle Hook, in sizes ranging from 9 (small) to 4 (large). Other kinds include Gamakatsu, Eagle Claw, O'Shaughnessy, BKN, Tankichi and Wide-gap hooks.

Curved hooks

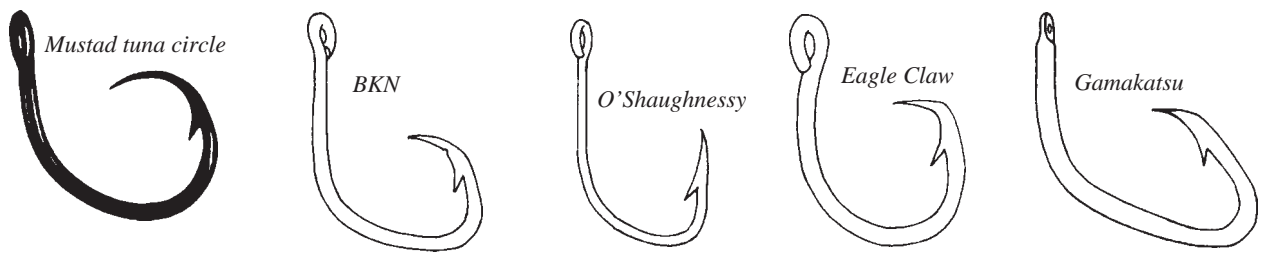

The main disadvantages of curved hooks are the relatively high cost, and the fact that they are more difficult to bait than straight hooks. However their advantages in terms of number of hook-ups make curved hooks highly preferable for this kind of fishing.

Swivels

A swivel is normally incorporated into the deep-bottom fishing gear between the mainline and the terminal rig. The swivel helps stop the mainline becoming twisted during use. This is a particular problem when hauling a line on which one or more fish has been caught. The movement or angle of the fish can cause the line to twist considerably, especially if the fish is a grouper coming up with its mouth wide open. If fishing with a chum-bag, the line may twist on the way down, too. A swivel is thus an essential part of the deep-bottom fishing line. The most widely available are barrel swivels, and bullet or torpedo swivels.

Types of swivel

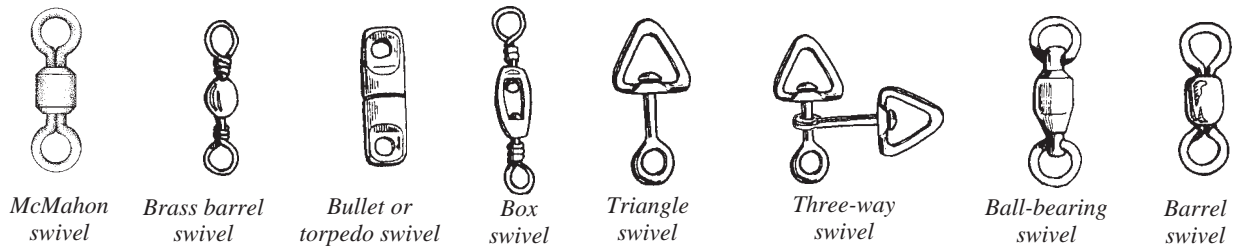

Types of snap clip

Some swivels come with snaps, clips or other 'easy-fix' devices which allow rapid changing of terminal rigs. The strongest types of snap clip are the pig-tail and the coastlock clip. Many snap clips are lightweight and often much weaker than the rest of the swivel, which causes them to break or open under the weight of a struggling fish.

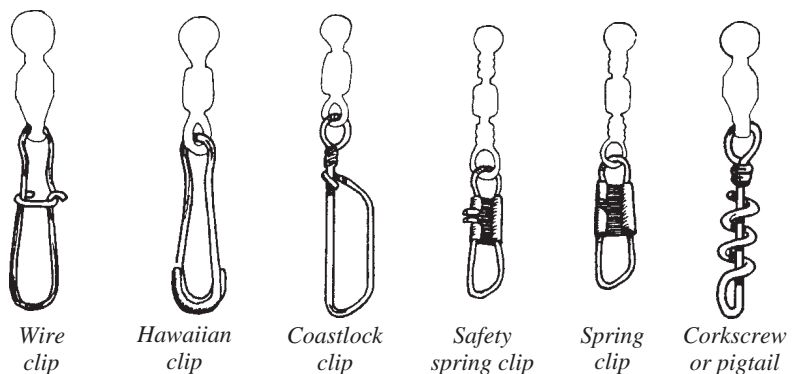

Sinkers

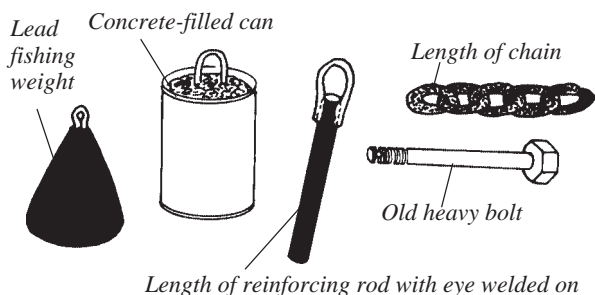

Sinkers

Any dense, heavy item weighing 0.5–2 kg and with an attachment point can be used as a deep-bottom fishing sinker. Sinkers often break off during fishing, so cheap throwaway items are the best. These include welded lengths of heavy steel reinforcing rod, lengths of heavy chain, and concrete-filled cans.

SECTION 2D: TOOLS AND UTENSILS

Most of the preparation for deep-bottom fishing is normally done on shore before the fishing trip starts. This makes gear rigging easier and more comfortable, prevents new materials being contaminated with salt water before they are used, and avoids wasting time at sea. Gear rigging is time consuming, and mastering some of the techniques, particularly when working with wires, requires plenty of patience. However, gear rigging principles are easily learned, and will develop with practice.

The most important thing about gear rigging is to have on hand the right tools and materials for the job. The tools needed will vary depending on the materials being used, but are mostly general-purpose items available through hardware or other retail stores.

Working with nylon

When working with nylon monofilament, only basic tools are needed. These include a pair of standard pliers, a good knife and a sharpening stone (oilstone or whetstone). Knives should be sharpened regularly.

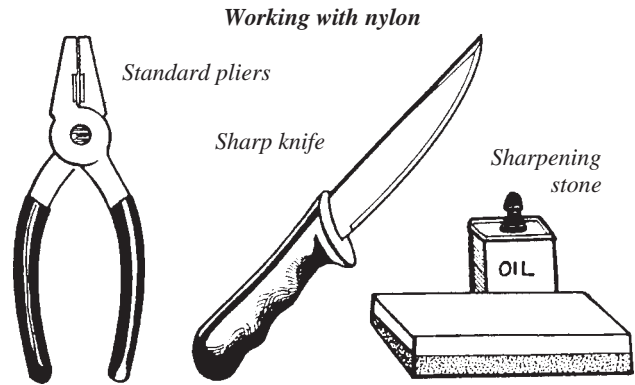

General rope work

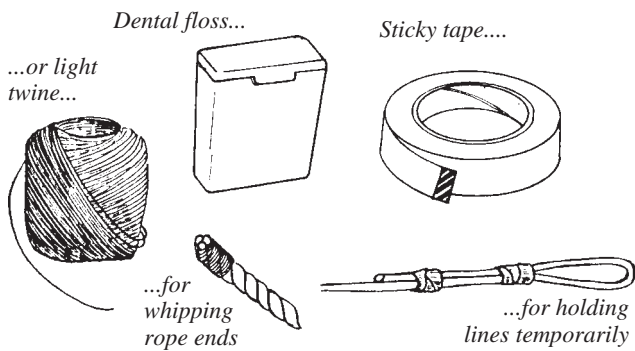

General rope work

For general work with ropes and lines, it is useful to have on hand adhesive tape, light string or twine, and, if available, waxed dental floss. These are used for whipping rope ends, temporarily attaching or holding line, and more.

Working with wire

If using wire, a pair of wire cutters or snips will also be needed. Cutters are preferred as these can be sharpened using a small file. For some types of cable, crimping pliers and crimps or sleeves of the correct size may also be needed.

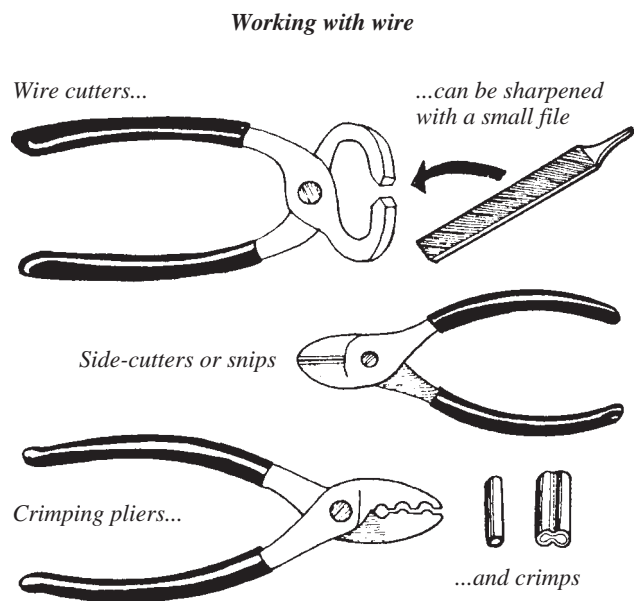

Storage of lines and terminal rigs

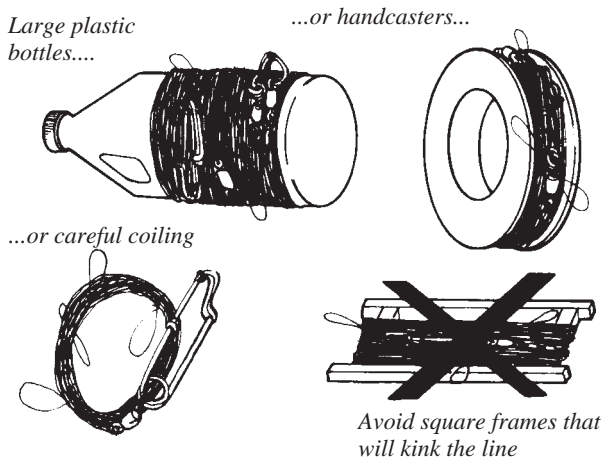

Storage of lines and terminal rigs

For the storage of completed lines and terminal rigs, plastic or wooden handcasters are useful and can be improvised if not readily available. The diameter should be at least 20 cm — large enough to ensure that lines do not kink or bend. Rectangular wooden-framed line holders should not be used, as these tend to kink the lines, especially when used with wire.

Splicing

In some cases it may be necessary to splice ropes or cables. For this, a tool is needed to spread the lay of the standing part so that the end of the free strand can be passed between. This can be done using a fid or marlinspike made for the purpose. Alternatively, the job can be done using a screwdriver, a nail, or even a fish-hook with the barb filed off.

Various tools can be used...

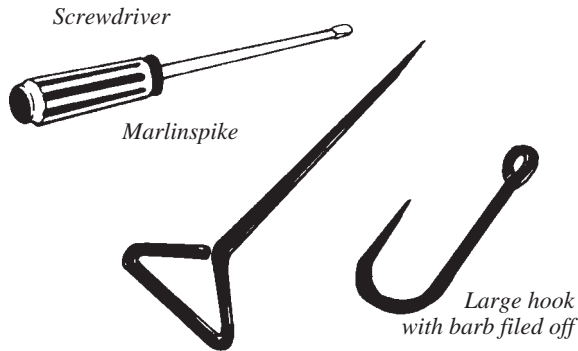

...for splicing multi-strand wire and rope

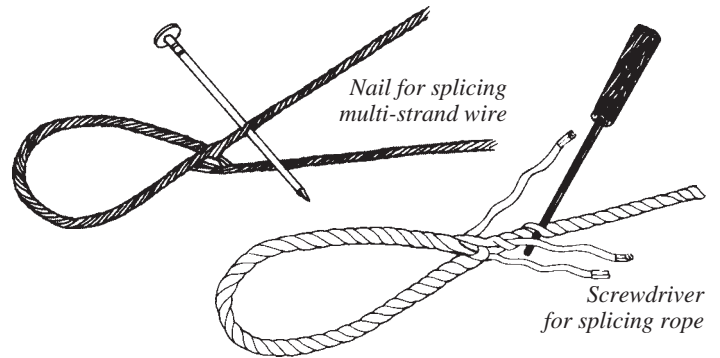

Hook sharpening

For cleaning and sharpening hooks, emery or glass paper and a small flat or three-cornered file are required (see section 5D).

Hook sharpening

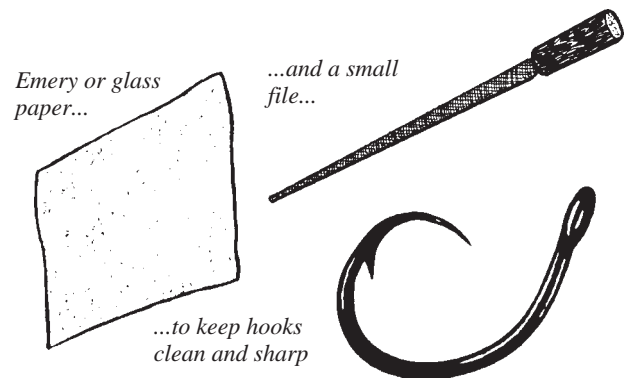

Rust prevention

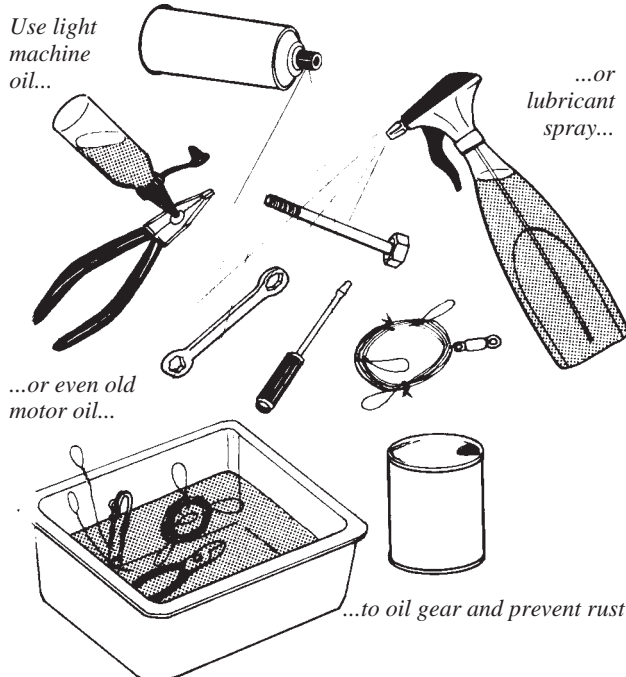

Rust prevention

To keep all metallic gear — e.g. hooks, wire, cable — and tools in good condition, wipe or wash off any salt water after use and oil well. Use ordinary motor oil or spray-on water repellent lubricant (e.g. CRC, WD-40). Reject oil drained from motor engines is perfectly okay.

In addition to tools, fishing tackle and materials will also be needed, as already shown in sections 2B and 2C. Methods for making up the fishing gear are described in the next few sections of this chapter

Fishing materials

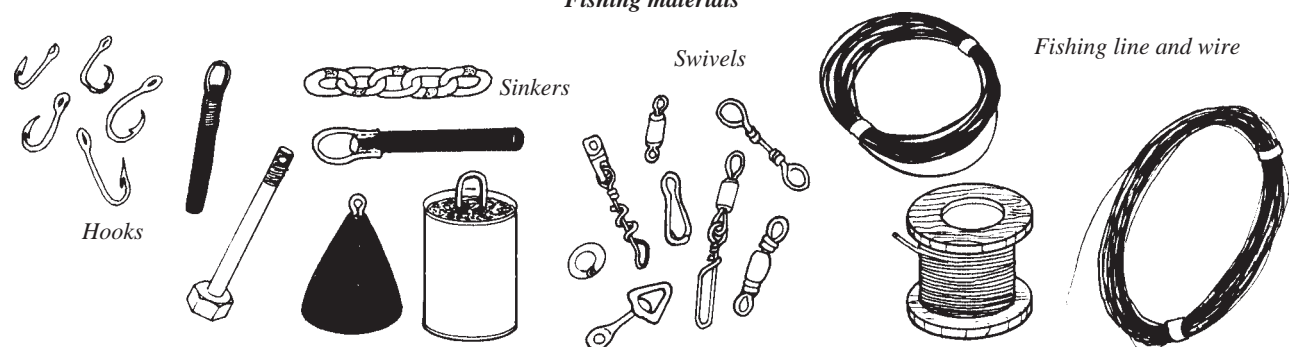

SECTION 2E: KNOTS FOR HOOKS AND TACKLE

Nylon monofilament fishing line is slippery and does not grip well when tied. Many knots will come undone under tension, even if they appear secure when tied. Some knots which will hold, and which can be used for attaching tackle to monofilament lines, are shown below.

Palomar knot

The palomar knot is popular among Hawaiian fishermen, who claim it is easier to tie and less likely to slip than other knots.

To tie the palomar knot:

- double the end of the line over in a loop;
- pass the loop through the eye of the hook or swivel and tie it loosely in an ordinary overhand knot;
- pass the eye of the loop over the body of the hook or swivel;
- pull gently on the standing part of the line and the tag end together to close the knot;
- tighten it up by pulling hard on the mainline;
- cut off the tag end close to the knot.

Palomar knot

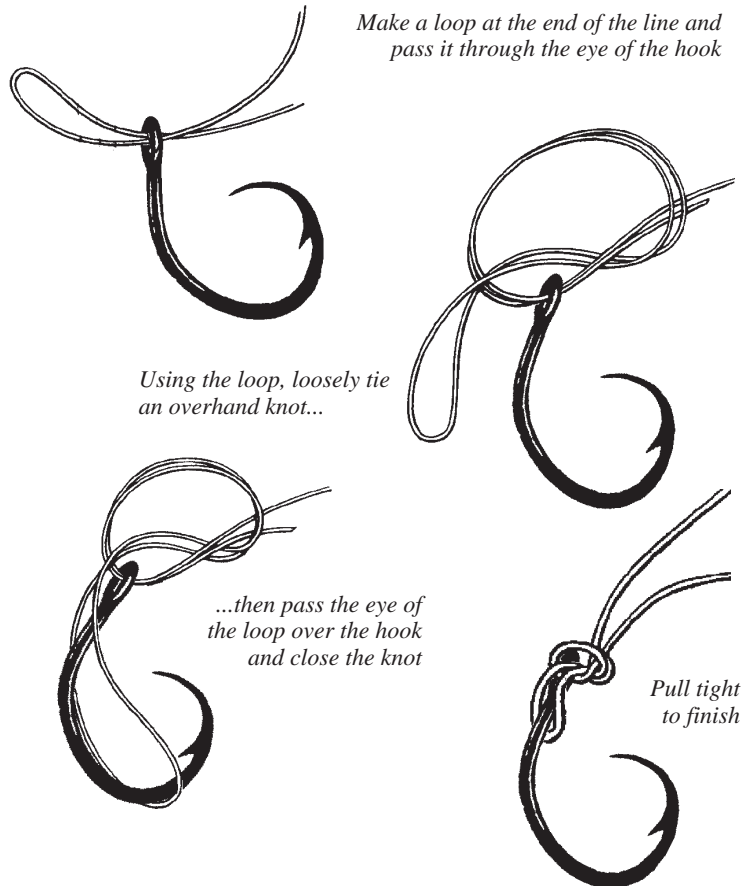

Clinch knot

Thread the end of the line through the swivel or hook eye

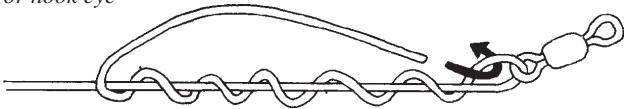

Put 4 or 5 twists in the line, then pass the tag end through the loop created...



...then bring the tag end back through the second loop



Clinch knot

This is a good knot for light monofilament. To make it:

- pass the end of the line through the eye of the hook or swivel and double it back;
- rotate the hook or swivel four or five times, twisting the tag end around the standing part. (Lubricate the lines with saliva to make it slip more easily);
- pass the tag end back through the loop at the end of the twist and pull gently so that the knot starts to close up;
- pass the tag end back under itself;
- hold the hook or swivel with pliers and pull hard on the mainline so that the knot pulls tight.

Pull the tag end tight and cut off close to the knot, then flatten it with pliers or your teeth so that it cannot slip or be pushed back through.

Snell knot

This is a quick and reliable way to attach hooks using monofilament. The knot is made as shown in the diagram.

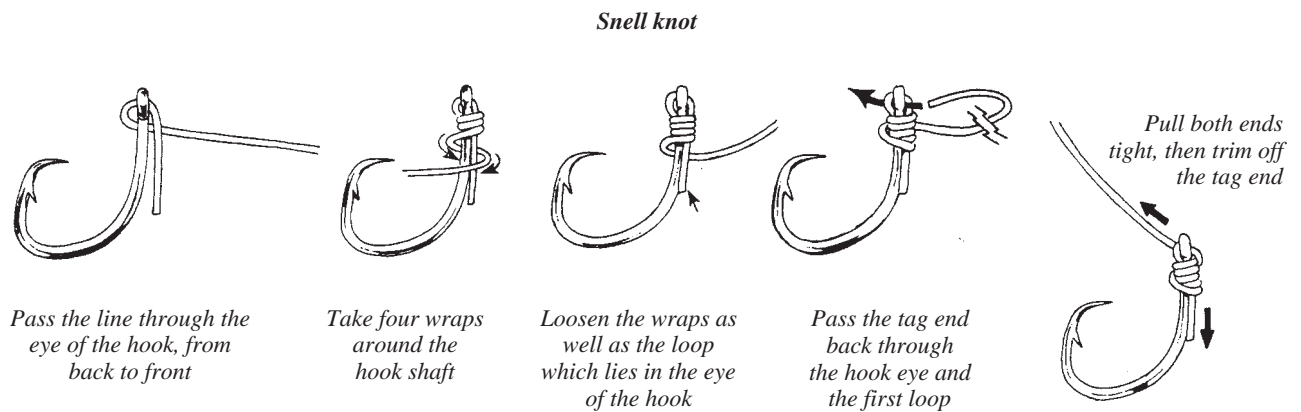

Slip knot

As well as being good for heavy monofilament, this knot can also be used for braided lines like super-toto, dacron, etc., whose rough surface prevents slipping and makes the clinch knot (above) hard to pull tight.

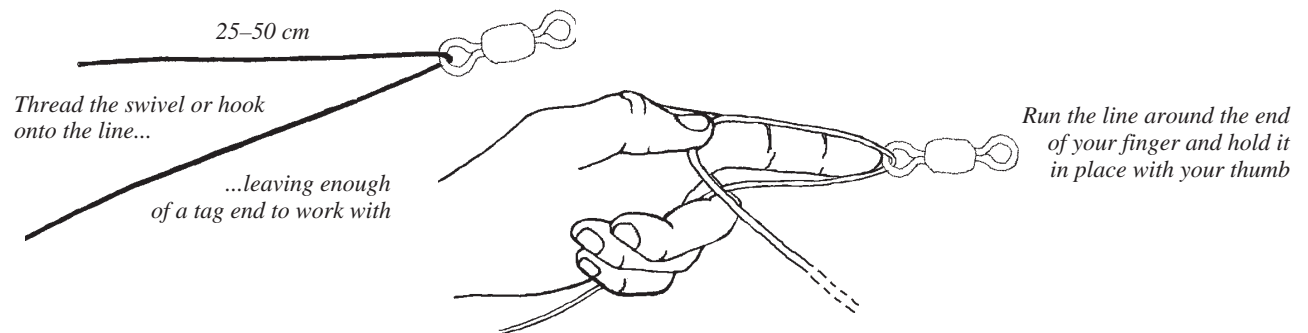

To make the slip knot:

- thread the line through the eye of the hook or swivel, leaving about 25–30 cm of line to work with;
- run the line down the inside of your forefinger, around your fingertip, and up the back of the finger, leaving the hook eye pulled against the fingertip;
- take four or five loose turns with the tag end around the finger, working back towards the fingertip;
- pass the tag end back along the finger inside the loose turns;
- remove the finger, holding the turns in place with the other hand, and pull gently on the tag end.

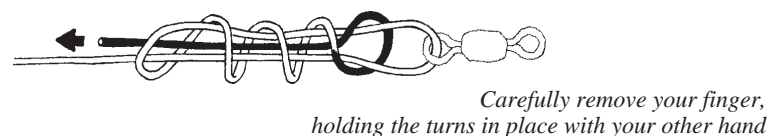
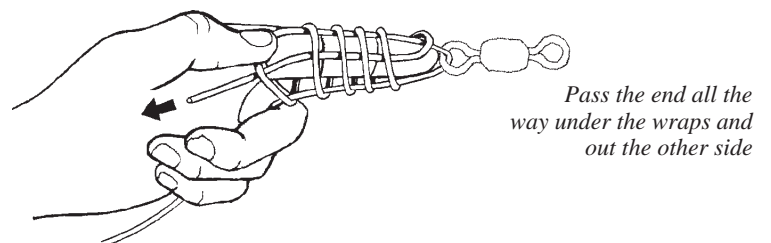
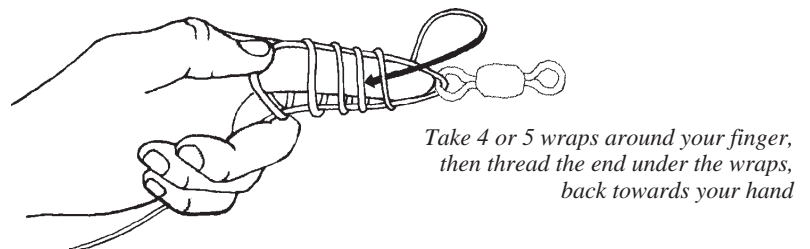

This will tighten the knot around the main line, leaving a long loop which can be pulled tight by holding the hook with pliers and pulling hard on the mainline.



Pull tight

SECTION 2F: KNOTS FOR JOINING LINES

Fishing is often carried out using monofilament or other light lines which cannot be spliced and which may slip unless special knots are used. All knots will weaken a line, sometimes reducing its breaking strain by more than half. The two knots shown below are recommended as being the strongest methods for joining monofilament and other fishing lines, and least likely to slip.

Blood knot

This is suitable for joining monofilament and similar lines.

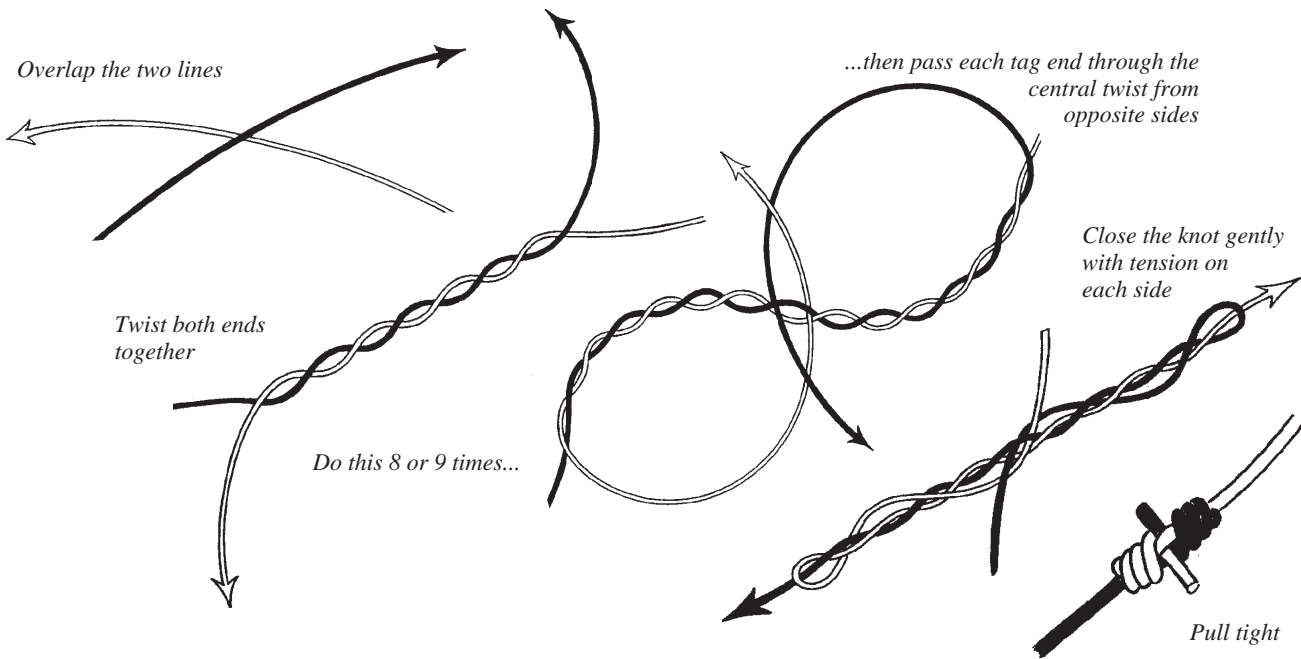

Double slip knot

Suitable for heavier lines or those which have a rough surface and do not slip easily.

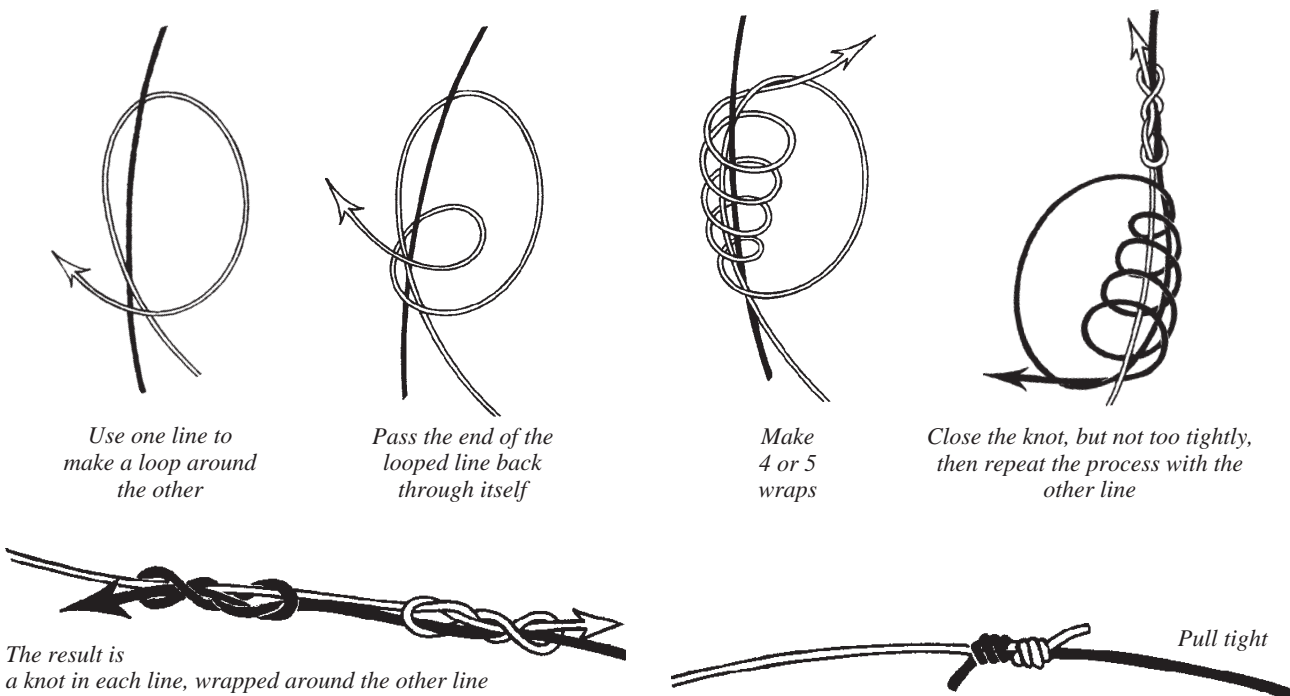

SECTION 2G: USING LOOPS TO JOIN LINES AND ATTACH TACKLE

Loops made at the end of a piece of line or at intervals along its length can serve as attachment points for other lines or for items of fishing tackle. The terminal rigs illustrated in section 2J are connected to the mainline via an end loop, while the traces that carry the hooks are attached to loops along the length of the rig. Knowing how to make strong loops in a variety of line materials is thus essential for making up deep-bottom fishing gear, and is illustrated in the next few sections of the present chapter. This section shows how to make and use end loops in nylon and other light lines. Sections 2H and 2I show how to make end loops in cable, as well as the harness knot used to make trace attachment points in both nylon and cable.

Double figure-eight knot

This knot is the most useful for making end loops in all types of line and will hold well even in nylon monofilament.

Double figure-8 knot

Double end of line over...



...pass doubled end around standing part of line...



...and back through loop

Using end loops

Hooks and swivels can be simply attached to monofilament line by threading onto the line before making the loop. Alternatively, they can be attached by passing the completed loop through the hook or swivel eye, and then around the body. This enables tackle to be disconnected and changed easily.

Attaching tackle using end loops



Thread the line through the eye of the hook or swivel before making the loop

Alternatively, thread the loop through the eye of the hook or swivel...



...and pull tight, making sure the line falls into the right position.



No good. The line may interfere with the action of the swivel



Lines can also be joined together using loops. End loops are made on the ends of each of the lines to be joined, and one loop is passed through the other in the manner shown below. This method is mostly useful for joining lines when one of them is fairly short, and is used in deep-bottom fishing to attach traces to the terminal rig.

Joining lines with loops

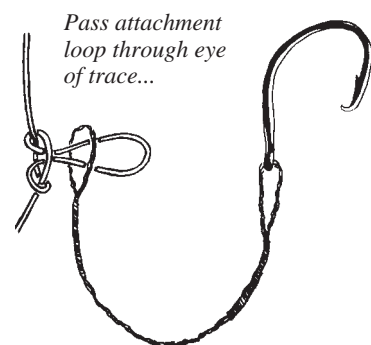

Pass attachment loop through eye of trace...

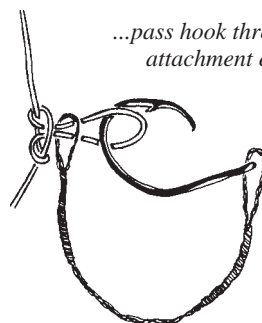

...pass hook through attachment eye...

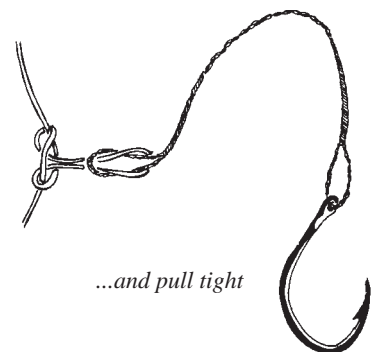

...and pull tight

SECTION 2H: END LOOPS IN CABLE

Some types of cable, such as 9-strand Turimoto galvanised longline wire, can be wrapped to form end loops. Turimoto cable is made up of three major strands, each of which consists of three minor strands, so there are nine individual wires in the body of the cable. Making end loops involves separating the major strands so that they can be wrapped around the standing part of the cable.

The best way to make an end loop in galvanised cable is to begin with a haywire twist, followed by individual wrapping of each major strand, as shown below.

- 1 Make a bend in the cable to form an eye or loop. Make sure you leave enough of a tag end to work with (15 cm or so).

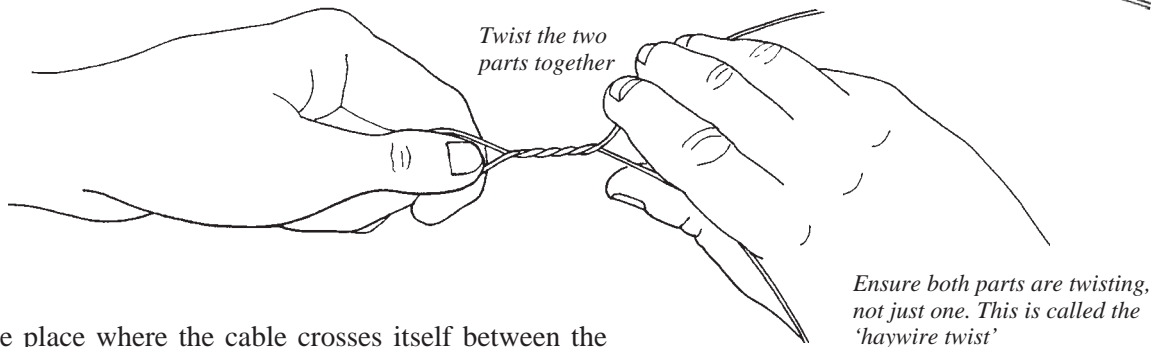
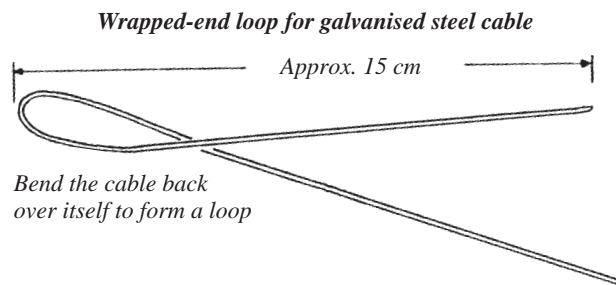

- 2 Hold the place where the cable crosses itself between the fingers and thumb of one hand, with one strand on each side of the hand to keep them separate. Grip the eye with the forefinger and thumbs of the other hand, or with pliers if necessary. Using both hands, twist the cable strands together.

Ensure that the two strands are truly twisting, rather than one staying straight and the other wrapping around it. Continue until the twist is 2–5 cm long. This is called a haywire twist.

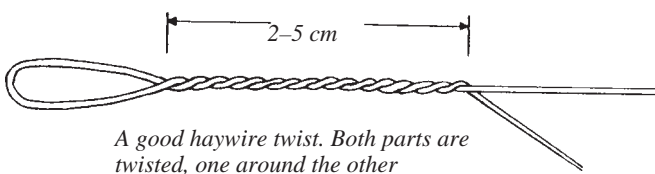

- 3 Separate the cable so that the three major strands can be handled individually. Wrap one major strand tightly three or four times around the main strand, and cut or break off its minor strands flush with the standing part of the wire.



- 4 Take the second major strand and repeat the process, wrapping it tightly around the standing part of the wire and covering up the ends of the first wrap. Cut or break off the excess.

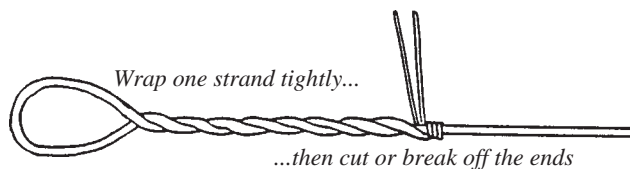

- 5 Finally repeat the procedure with the last major strand, covering up the ends of the second. The finished product should have a regular shape and no sharp ends sticking out. If sharp ends protrude at any point during the wrapping procedure, twist them down with a pair of pliers.

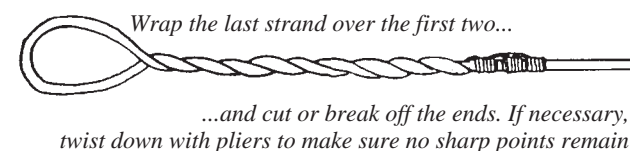
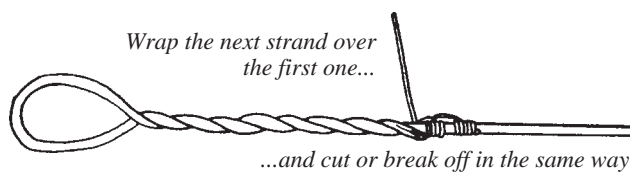

Simplified wrapped-end loop

An alternative way to make end loops in galvanised cable, which is quicker but less strong, is shown below.

Wrapping a simple end loop in galvanised steel cable

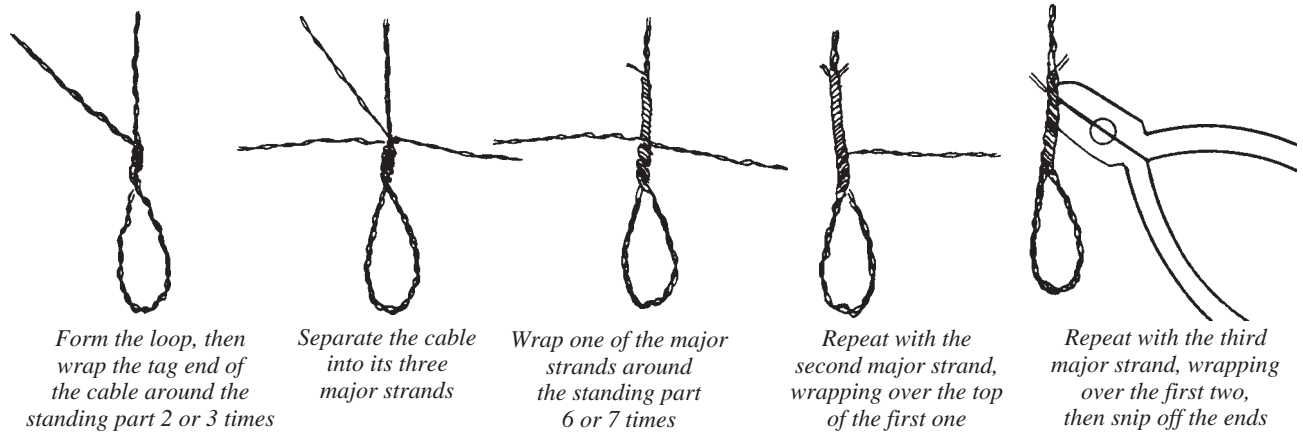

Flemish Eye

To strengthen an end loop in cable, and reduce the likelihood of it untwisting, you can make a 'Flemish eye'. To do this, tie an ordinary overhand knot in the cable, pulling the knot tight until the eye is about the size you want it. Pass the tag end back through the knot once more and start wrapping as above. The finished product is a stronger and more rigid end loop.

To make the Flemish eye...



...tie a double overhand knot in the cable before completing the loop

Crimps

Seven-strand and 49-strand stainless steel cable and similar products cannot be reliably wrapped or knotted and must be crimped using metal sleeves and crimping pliers. Crimps (also called sleeves or swages) can also be used to join monofilament lines together, or to attach hooks and swivels to monofilament and other fishing lines. Crimps are tubular lengths of brass, aluminium, or other suitable metal which are slid over the line and then pressed onto it using a special crimping tool. The crimp may be circular, oval or figure-8 shaped in cross-section, and when squeezed shut, grips hard on the line to prevent it from slipping.

Using crimps

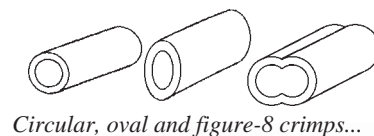

When using crimps to make end loops in cable, it is best to use two sleeves and ensure that they are the right size for the cable. Slide the sleeves onto the cable and then tie a Flemish eye as shown above. Pass the tag end through the first sleeve, push the sleeve hard against the Flemish eye, and crimp it tightly shut using the pliers. Wrap the tag end slightly around the main strand and crimp the other sleeve over the end, making sure the two strands are tight together and the end does not stick out.

Crimping end loops

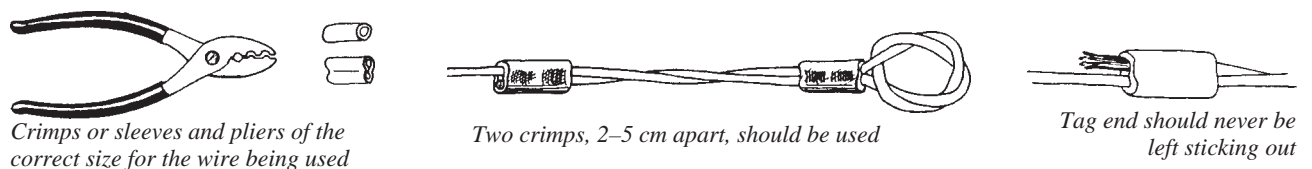

SECTION 2I: TRACE ATTACHMENT POINTS

There are several ways of making loops along the length of a terminal rig. These are used as attachment points for the short traces that carry the hooks.

Artillery loop knot

This is used to make attachment loops along a length of Turimoto multi-strand galvanised steel longline wire, or other types of cable. It can only be made in a fairly short length of line (say, 3–4 m maximum) because it requires an overhand knot to be made in the line, and this is impractical with very long lines.

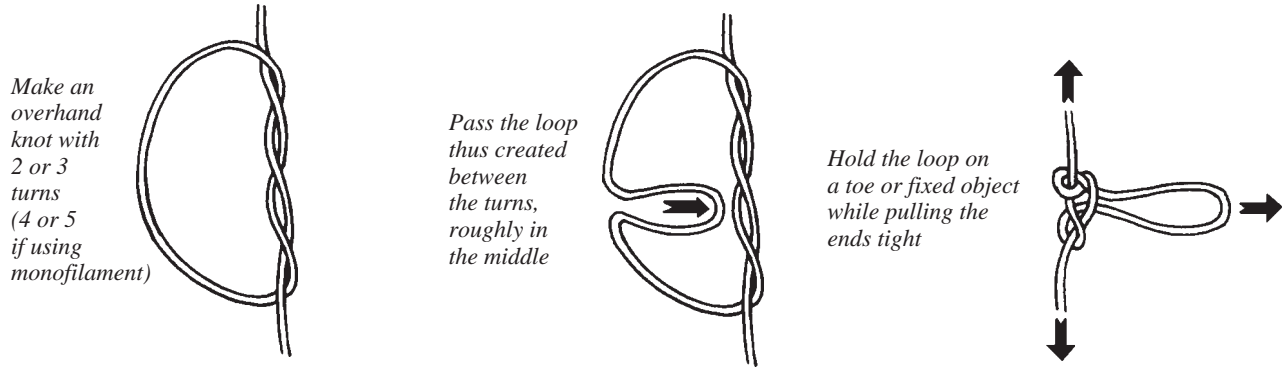

The artillery loop knot can also be used to make loops in a length of nylon monofilament. If using monofilament, however, a few extra turns should be taken in the initial overhand knot to prevent the loop from slipping under a heavy load.

Harness knot

This knot can be used for both cable or, more often, monofilament. If using cable, only a single turn is needed at step two, as opposed to three or four turns for monofilament.

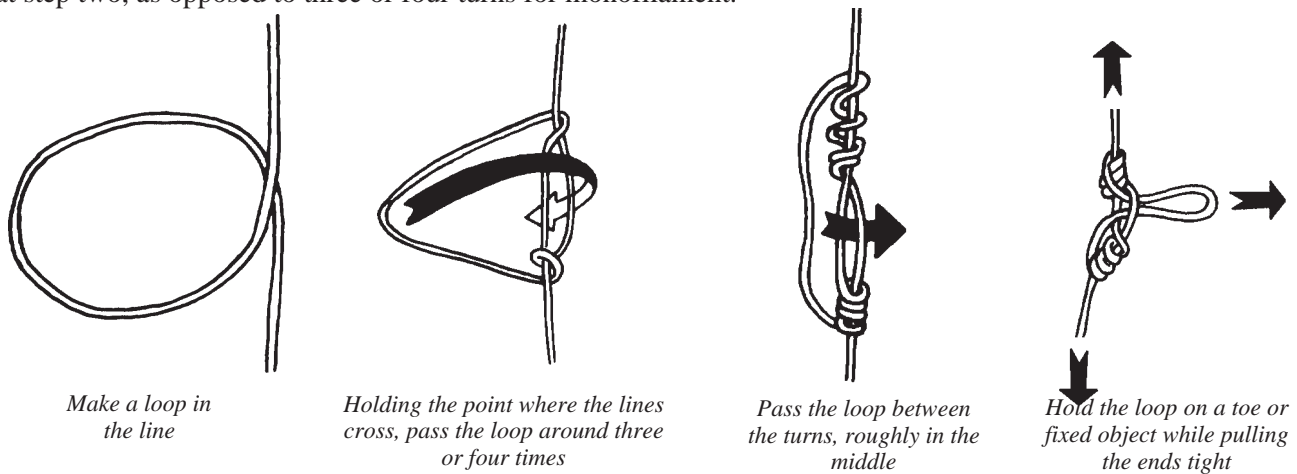

The harness knot is useful for making loops in long pieces of line, where it may not be practical to make overhand knots as required when using the artillery loop knot.

Three-way swivels

As an alternative to loop, three way swivels (or double swivels) can be fixed into the terminal rig at appropriate point along its length. Three-way swivels allow the trace to rotate, which is helpful in deep-bottom fishing, as many deep-bottom fish will spin on the line as they are hauled. If there is no swivel, this can cause the trace and terminal rig to become twisted or, occasionally, to break. Nevertheless, three-way swivels are not widely available, and where they are they may be expensive. They are thus not widely used in deep-bottom fishing.

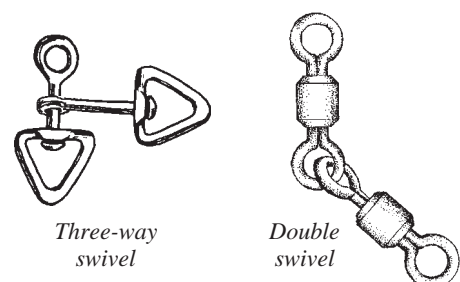

SECTION 2J: THE ASSEMBLED LINE

The completed deep-bottom fishing line is made up of two main parts:

- the **mainline** makes up most of the length of the line and is used to get the hooks to the bottom. Nylon monofilament of 100 kg to 300 kg breaking strain is the usual material, but braidline or other types of line can also be used. Stainless steel cable has also been experimented with but the weight of the cable in the water makes it hard for the fisherman to tell when the sinker hits bottom. Line length depends on the fishing depth, but normally should be at least 500 m.
- the **terminal rig** carries the baited hooks and sinker and, in some cases, a chum-bag. It may be made of nylon, in which case it is usually of lower breaking strain than the mainline. Alternatively, steel cable may be used, the most popular material being Turimoto 9-strand galvanised steel longline cable. An end-loop is made at the top for connection to the mainline, and at the bottom for the sinker. Several attachment points for traces are spaced along the rig's length, made using one of the knots shown in section 2I, or using three-way swivels.

Different terminal rig arrangements

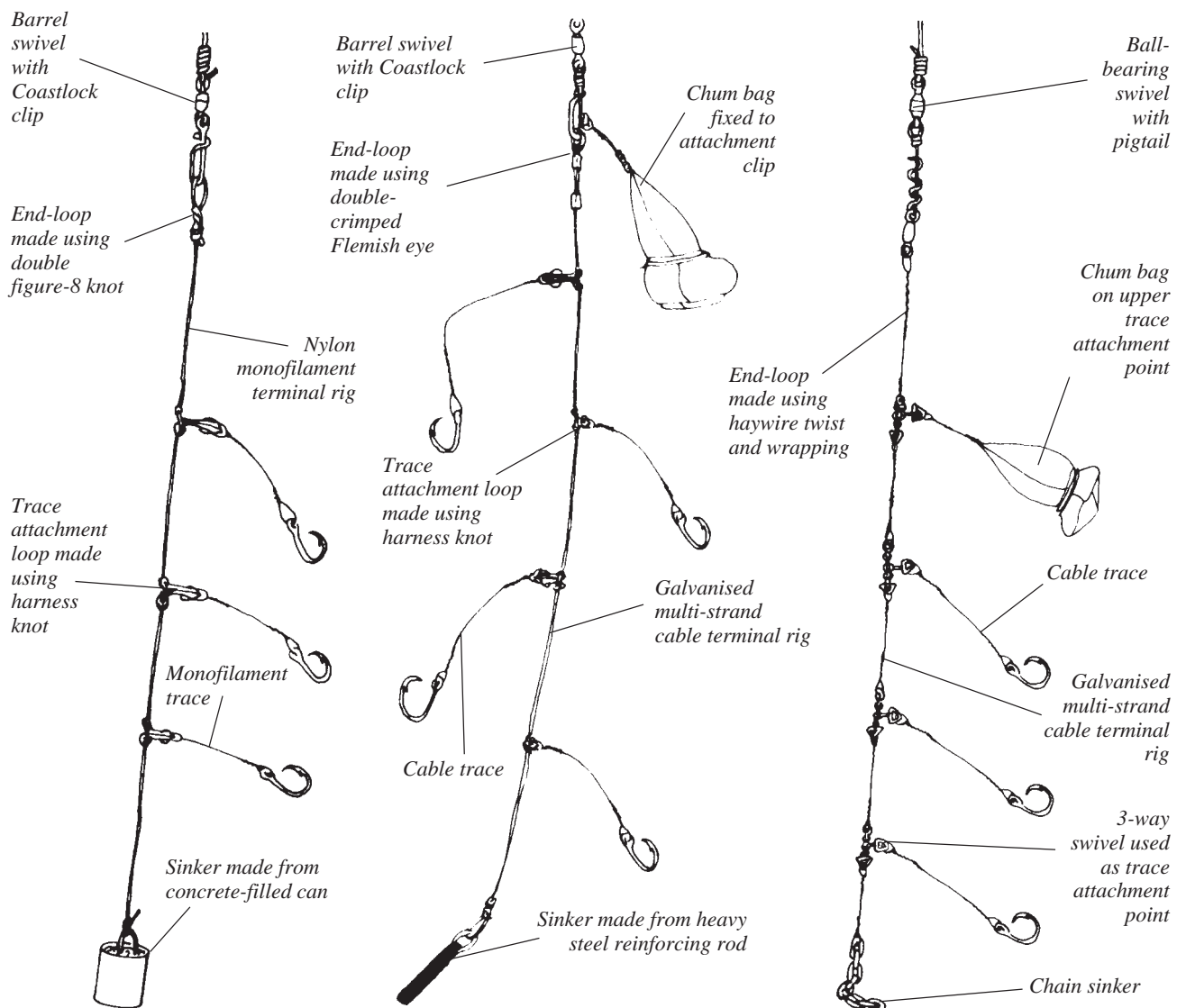

In assembling the terminal rig, many fishermen prefer to put larger hooks at the top of the rig, and progressively smaller ones lower down. In many fishing situations more smaller fish are taken close to the bottom, with fewer but larger fish higher up. For this reason, most fishermen also prefer to place the chum-bag (see section 2M) on the upper attachment point.

When fishing on smooth or sandy bottoms, sinkers can be attached directly to the terminal rig. On rough or rocky bottoms, however, it is better to attach them using a short length of light line which can break off if the sinker gets stuck, so that the terminal rig (and any fish caught) can be retrieved more easily.

SECTION 2K: REELS FOR BOTTOM FISHING

Bottom-fishing is often carried out using a simple handline. In shallow waters the line need not be too long, and can be coiled onto a handcaster or bottle for storage. In deeper waters, however, the length and relative thickness of the mainline make this impractical, so the line is usually allowed to fall freely into the bottom of the boat or into a box or bucket.

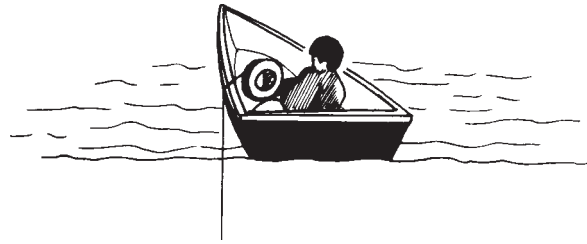

Some fishermen still prefer to use this method because they say it allows them to strike more rapidly when the fish bite. However there are a number of problems with using such long handlines. One is the length of time that it takes to hand-haul such a length of line in deep waters. Once the line is in the boat, there is a potential for messy line tangles that can take hours to undo. When a large fish such as a shark takes the hook, it can be difficult to control and may injure the fisherman's hands. In fact just normal handling of the line will inevitably cause cuts, burns and blisters. In addition, rubbing of the line on the edge of the boat can wear the line and leave deep cuts in the gunwale, especially if braidline is being used.

Using handlines for deep bottom fishing...

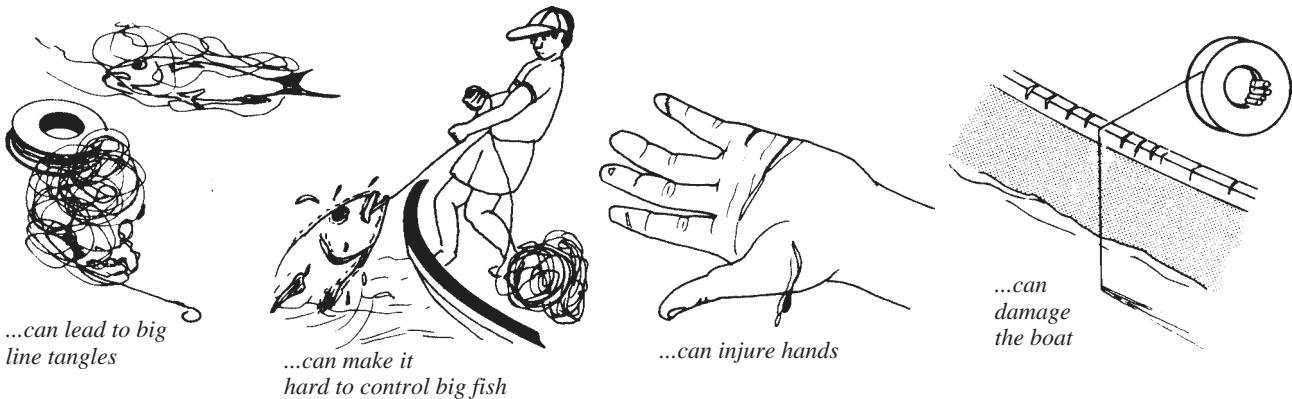

Fishing reels allow the line to be properly controlled. Reels increase the speed at which line can be recovered, allow the fisherman to play large fish more easily, avoid hand injuries, keep the line away from the boat most of the time, and avoid tangles by keeping the line stored compactly. The main disadvantage of fishing reels is that they are an extra cost to the fisherman. In addition, badly made or positioned reels can be difficult to use and can cause muscle strain. However these problems can be solved — the cost of reels will be recovered over time by increased efficiency and productivity, while backaches can be avoided by proper reel construction and positioning. Most fishermen who get used to fishing with a reel will not go back to using a handline.

Many varieties of fishing reel are available commercially, and several are suitable for deep-bottom fishing. These are usually fitted with friction brakes and an easily adjusted mounting system, and most are robust and constructed from materials which will last for a long time even in the marine environment.

Some commercial deep-water fishing reels

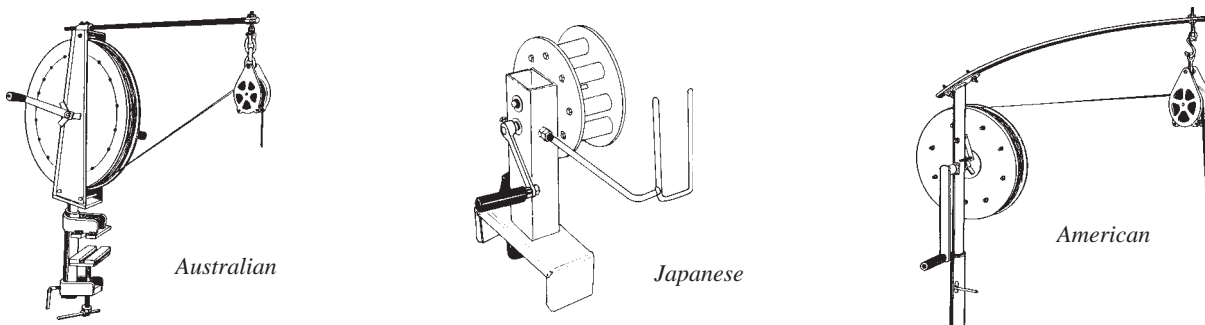

Unfortunately reels like this are usually expensive (typically US\$ 500–1,000) and of limited availability in the Pacific region. In addition, spare parts may be unavailable and damage may be difficult to get fixed locally.

A better solution for small fishermen in the Pacific Islands region is the wooden handreel shown below. The reel was first introduced into Western Samoa in 1975 by FAO, and has since been promoted by SPC as well as by many Pacific Island Fisheries Departments. These reels are commercially produced in many places, and can also be made by the fisherman himself using simple tools and locally available materials.

The wooden handreel and its parts

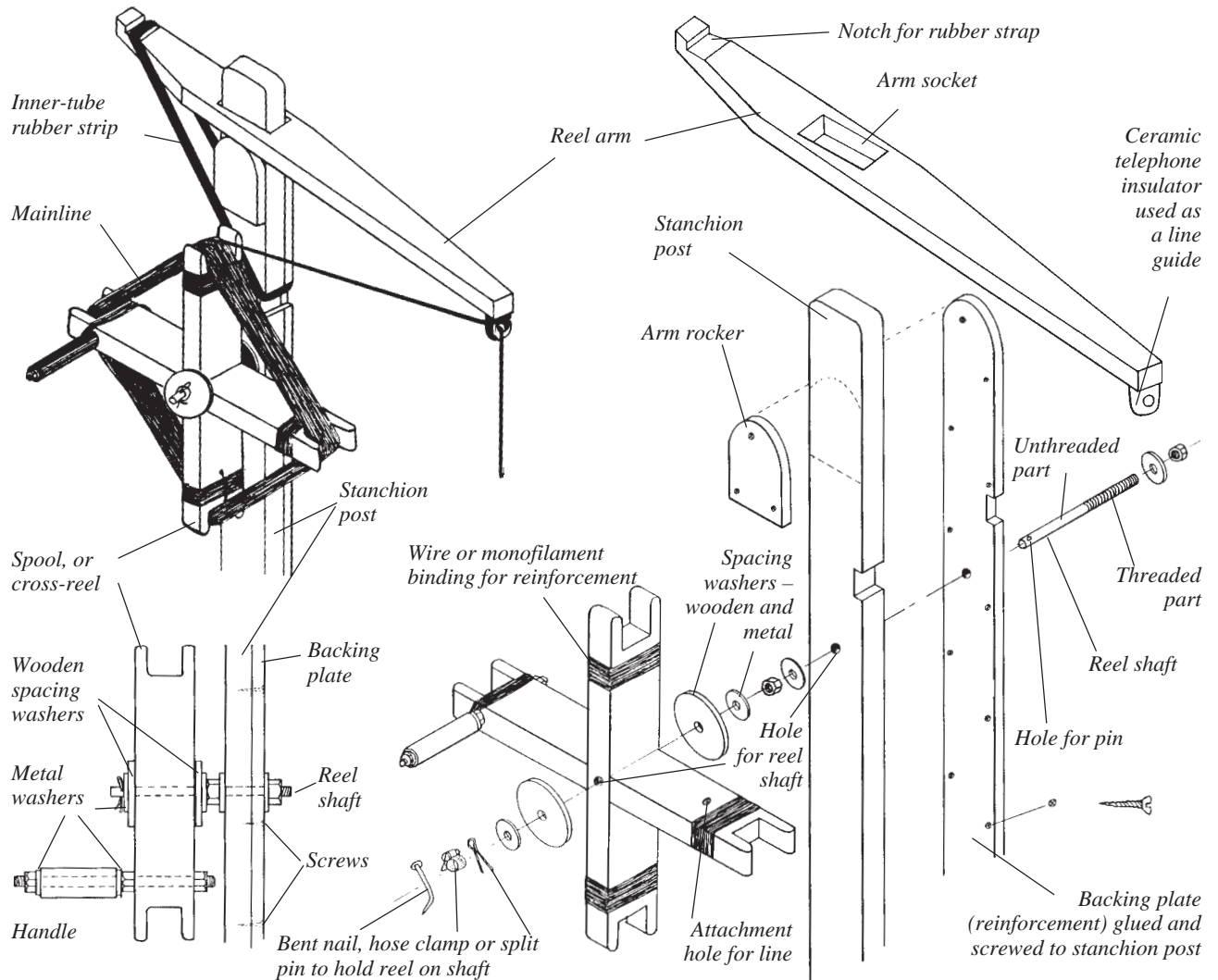

Although quite simple in appearance, a lot of care must be taken when constructing this reel if it is to work properly. A badly made reel will cause much frustration, reduce the effectiveness of fishing operations, and may break at the most important moment—that is, with a large fish on the line. For these reasons, the SPC has produced a separate handbook which gives detailed instructions and plans to enable proper construction of the FAO Samoan reel (*SPC Handbook No 25: Notes on the construction of the FAO wooden handreel*), available from SPC.

The most common fault in making these handreels is poor alignment of the line, which causes it to ‘miss’ the reel when being wound in. To ensure good alignment it is very important that the holes for the reel shaft and the lever arm are cut straight and accurately. Only limited adjustment is possible by adjusting the insulator position or adding more spacing washers to the reel shaft.

In addition to wooden handreels, other, more elaborate reels can be improvised by the enterprising fisherman, especially those with metalworking skills or facilities. An example shown here is the ‘Velo’, a reel made from an old bicycle frame, first developed in Vanuatu. This reel has the advantage that it can be wound using both hands, or, on some models, with both feet (by re-fitting the bicycle seat), and that it uses the bicycle’s gearing system to increase hauling speed.

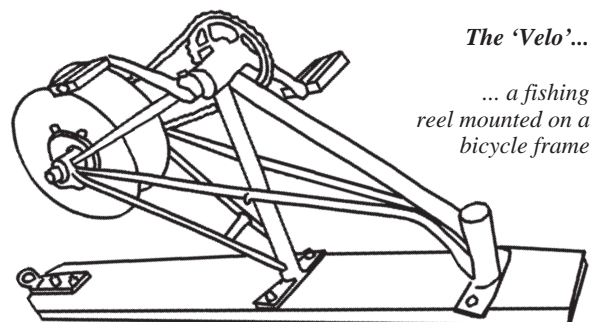

SECTION 2L: BAIT

Bait is of prime importance when deep-bottom fishing. Pulling lines up and down for several hundred metres is hard work, so it is important to make sure the bait is working properly, staying on the hook and attracting fish.

For almost all types of fishing, the fresher the bait, the better it works. When the fish are biting well, almost any kind of bait will work: but when the fish are 'fussy' and hard to catch, fresh bait will out-fish frozen or salted bait, and old, smelly bait will be almost useless.

A good bait is fresh, has plenty of oil content (so as to give a good odour and draw fish in from a distance), and is strong enough to stay on the hook. Unfortunately, it is not always easy to find bait with all these features.

Commonly used bottom-fishing baits

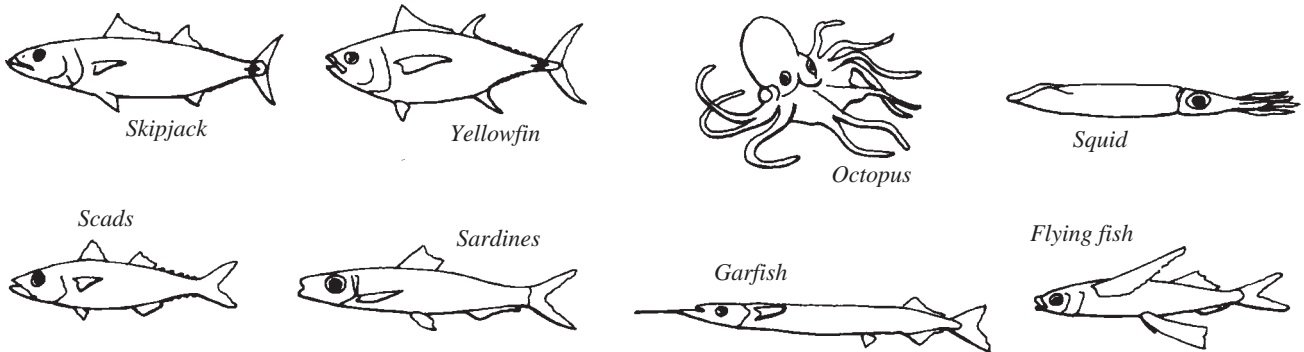

Cutting bait

Bait should be cut to a size which fits the hooks being used. Small fish can be cut into sections along the length. Larger fish should be filleted and the fillets cut into the right-sized pieces. Very thick fillets should be thinned down if necessary. Always leave the skin on the bait to help keep it on the hook.

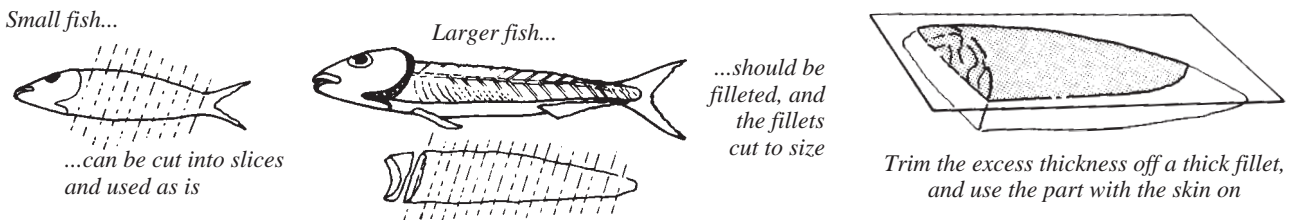

Baiting the hook

When baiting the hook, remember that the idea is for the point and barb to catch in the fish's mouth. Make sure the bait is not too thick, so the point and barb stick out a little. If there is too much bait, the fish can get a grip on the hook without being caught. Also, make sure there are no bones or fins in the bait which will interfere with the hooks action.

Whenever possible, bait should be double-hooked to reduce its chances of falling off the hook. Most bait pieces are tapered, with a thick end and a thin end. The point of the hook should be inserted into the skin side of the thin end and out through the flesh side. The hook is then passed through the bait a second time, by inserting into the flesh side of the thick end and out through the skin side. The result is a double-hooked bait with the skin on the outside.

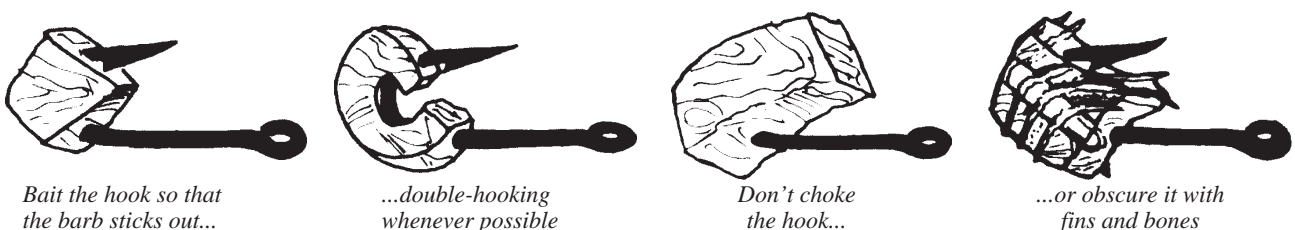

The best way to bait any hook, especially a tuna circle, is to hold the bait still and rotate the hook into and through it. If the bait is a little soft, it can be held on the flat of the fingers and the hook rotated through it and between the fingers, so that it is supported at all times.

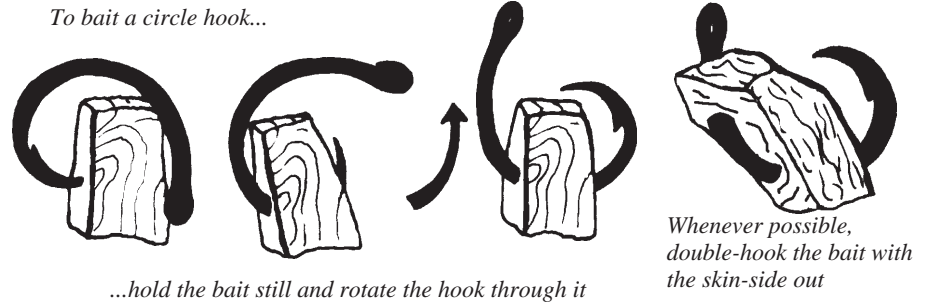

Hardening bait

Oily bait such as tuna easily becomes soft and mushy, especially after it has been frozen. This makes it difficult to bait the hook without squashing the bait, and causes it to fall quickly off the hook. To prevent this, the bait can be hardened by salting for a short period before fishing. To harden bait, cut it into the right-sized pieces, then sprinkle with plenty of salt, or mix in a bucket with about a third as much salt as there is bait. Do not add any water, 2–3 hours in the salt will toughen up the outside of the bait chunks and make them hold on to the hook better.

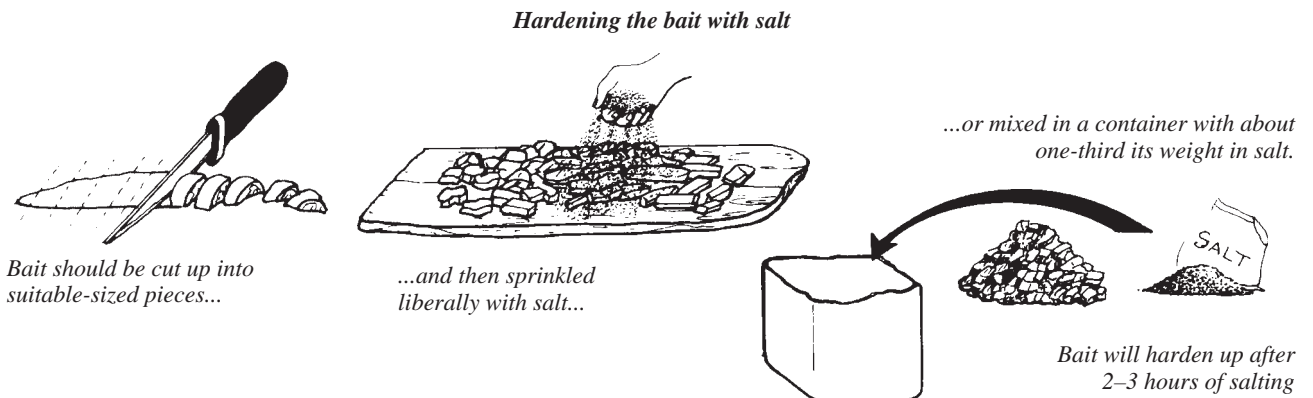

Preserving bait

Salting more heavily is a good way of preserving bait in places where there is no refrigeration, or where bait is hard to come by. Cut pieces or whole fish can be salted, but whole fish larger than 1 kg should be filleted or cut into pieces smaller than 1 kg each. Simply mix the bait pieces with their own weight in salt, stir them up, and then store them away for later use.

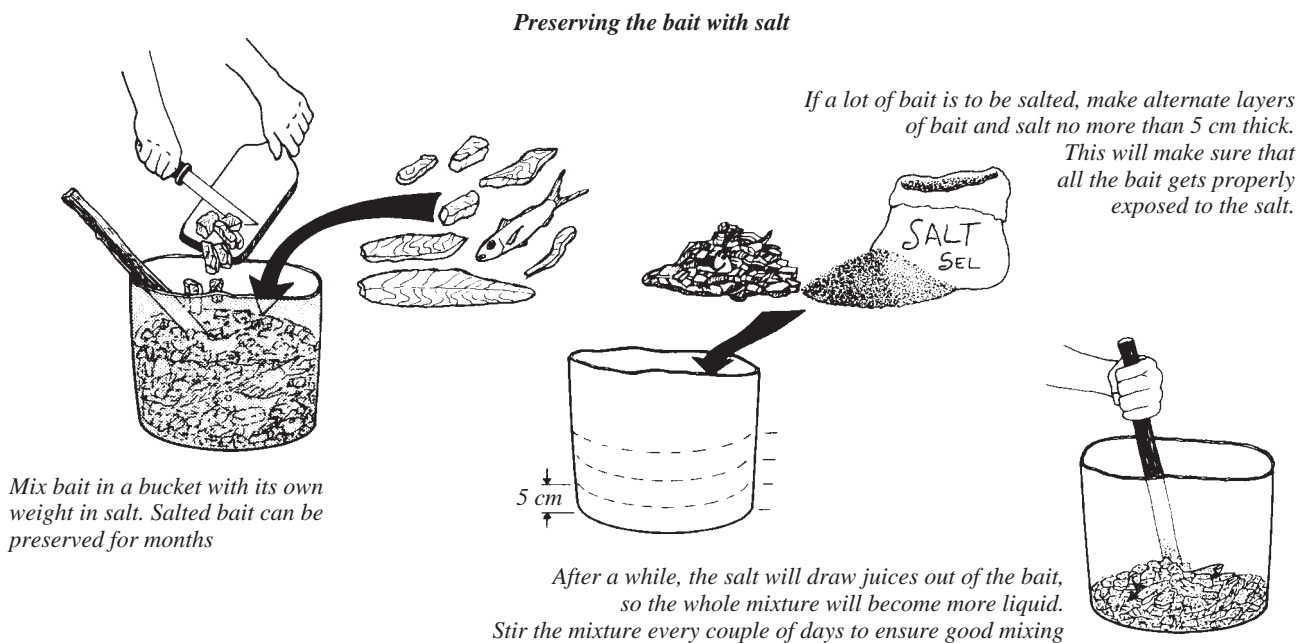

For larger volumes, place a layer of bait no more than 5 cm thick in a bucket, add an equal weight of salt, then add more layers of fish and salt. Do not add any liquid - plenty of juice will be drawn out from the fish. Mix the fish and salt well, and stir up from time to time. Bait salted in this way can be kept for months.

SECTION 2M: CHUM

Chum is very finely ground or chopped bait which is released into the water at intervals while fishing, to attract the fish to the fishing spot. The chum is meant to excite the fish by its smell, but the particles should be too small to allow them to feed properly. The fish search for the source of the smell, and eventually find the baited hooks, which they bite in their excitement. Chumming is normally done at anchor, but can be effective when drift-fishing as long as there is little wind and the current moves the boat along with the chum.



Chum

The ideal place to release the chum is close to your bait, preferably just up-current. The chum sinks down, drifting with the current, so that a cloud of odour and particles moves downstream from your bait. When a group of fish meet the odour they will tend to swim against the current, looking for its source. Repeated chumming provides the fish with a trail of odour that leads to the bait.

Chumming in shallow water is easy: handfuls of chum can simply be thrown over the side from time to time. In deeper water, the chum will take longer to sink, so some fishermen mix sand with it to help carry it down faster. In very deep water neither of these methods will get the chum to the seabed before it disperses far and wide, so a chum-bag, as shown on the opposite page, is used.

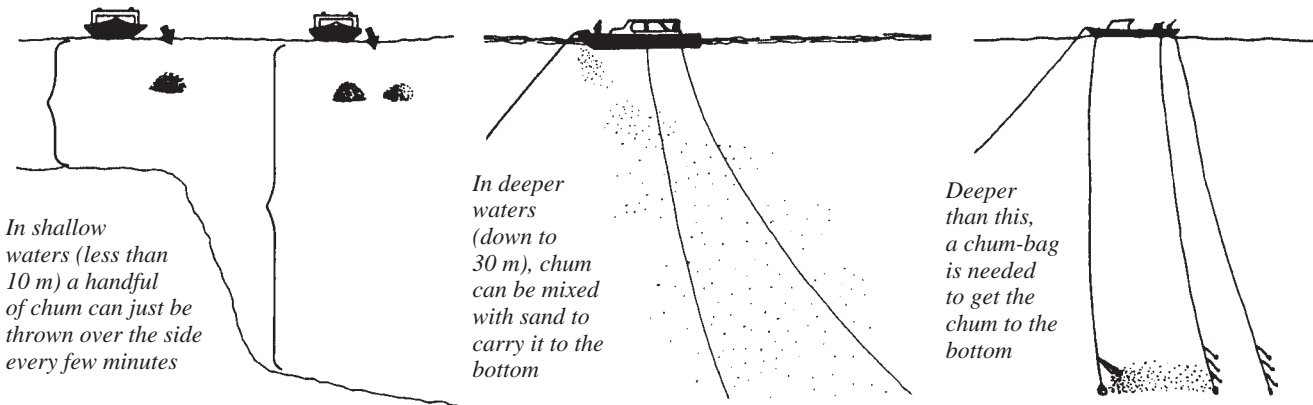

Making chum

The important thing in making chum is to ensure that the bait is chopped or ground into very small pieces, so that the fish cannot feed properly on it. Chum can be made by chopping up bait or waste fish with a heavy knife or a meat cleaver. The bait has to be chopped for a long time to get the particles small enough and they tend to fly around in all directions.

A better way is to boil waste fish heads, skeletons, and even guts. Boiling should continue until the fish and bones are properly broken up.

A third way is to buy a mincer (meat grinder) and use it to mince up fillets of bait or trash fish. Most mincers will not handle bones and are easily clogged by scales or skin, so this method is not so good for making use of waste parts of fish.

Another good (but expensive) type of chum is tinned fish, which is easy to mash into small pieces and has no hard bones.

Making chum

Chum can be made by chopping...

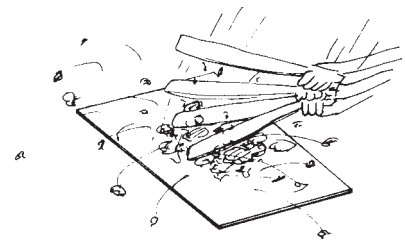

...boiling...

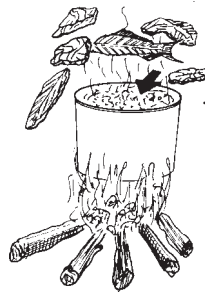

...or mincing

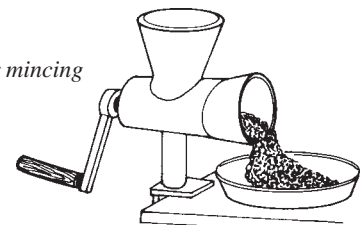

Mashed-up tinned fish is also an effective, if costly, kind of chum

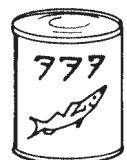

'Stretching' chum

All types of chum can be 'stretched' by mixing in flour, or cooked, mashed starchy foods such as rice, yam, sweet potato, taro, cassava, etc. As well as making the chum go further, the starch thickens the mixture so it is easier to use. The chum should have a thick texture, like mashed potatoes, or a thick stew. Another good additive is grated coconut flesh, which adds oil to the chum mixture and helps disperse the odour.



Starchy foods such as rice, breadfruit or taro, which may be locally cheap, can be used to stretch the chum

Preserving chum

Once made, chum can be frozen until ready to use. Alternatively, it can be preserved for weeks by salting. To do this, mix in salt to half the weight of the chum and stir every few hours for the first 3–4 days. After this, the chum can be stored away until ready for use.

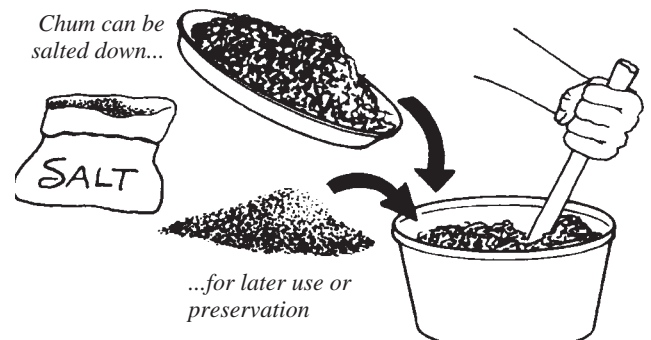

Making a chum-bag

Take a 25 cm-square piece of denim...

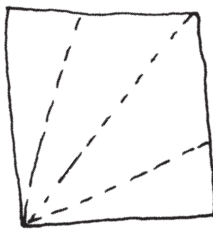

...and stitch two adjacent sides together to form a cone

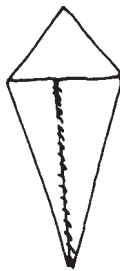

Then attach a swivel with a snap clip (or, if unavailable, a loop of line) to the point

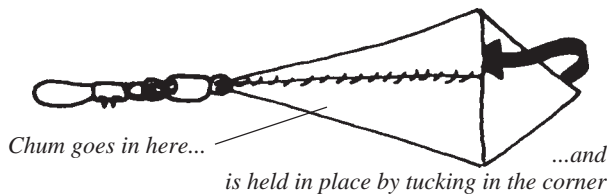
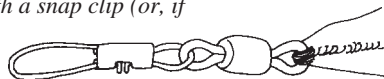

Chum-bag

A chum-bag is attached to the terminal rig and is used to carry the chum to the bottom, where it opens so that the chum can disperse.

The bag is made from a 25 cm x 25 cm square of denim, canvas or other heavy cloth. Fold over two adjacent edges so that they meet in the middle as shown, and stitch them together. This gives a long cone-shaped bag with a flap at the end which can be tucked in after the bag has been filled with chum. Sew or tie on a snap swivel (or an eye made of strong cord) which can be used to connect the bag to one of the attachment loops on the terminal rig. Many fishermen prefer to use the uppermost attachment point, both so that the chum will shower down on the other hooks, and because the top hook is usually the one that catches fewest fish.

The chum-bag is clipped or tied onto the terminal rig immediately before fishing, filled with chum, and the corner flap tucked in firmly to close it. The line is allowed to sink to the bottom, being careful not to tug or jerk on it, so as not to accidentally release the chum. Once the sinker touches bottom, the line is tugged sharply a few times. This opens the bag and the chum is released, raining down over the other hooks before being dispersed by the bottom current.

Chum bag is allowed to free-fall to the sea floor...

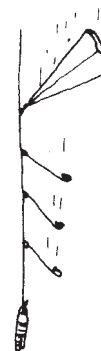

...then the line is tugged to release the chum

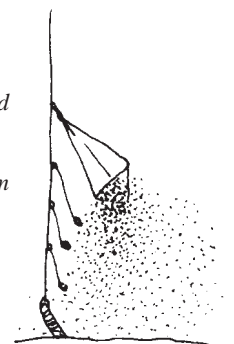

Some fishermen operate the chum bag from a separate line so that it will not interfere with their fishing, and so that they can make sure the chum is released up-current of the other lines.

