

CHAPTER TWO

Fundamentals of Steam Power

2.1 Introduction

Much of the electricity used in the United States is produced in steam power plants. Despite efforts to develop alternative energy converters, electricity from steam will continue, for many years, to provide the power that energizes the United States and world economies. We therefore begin the study of energy conversion systems with this important element of industrial society.

Steam cycles used in electrical power plants and in the production of shaft power in industry are based on the familiar Rankine cycle, studied briefly in most courses in thermodynamics. In this chapter we review the basic Rankine cycle and examine modifications of the cycle that make modern power plants efficient and reliable.

2.2 A Simple Rankine-Cycle Power Plant

The most prominent physical feature of a modern steam power plant (other than its smokestack) is the *steam generator*, or boiler, as seen in Figure 2.1. There the combustion, in air, of a fossil fuel such as oil, natural gas, or coal produces hot combustion gases that transfer heat to water passing through tubes in the steam generator. The heat transfer to the incoming water (*feedwater*) first increases its temperature until it becomes a saturated liquid, then evaporates it to form saturated vapor, and usually then further raises its temperature to create superheated steam.

Steam power plants such as that shown in Figure 2.1, operate on sophisticated variants of the Rankine cycle. These are considered later. First, let's examine the simple Rankine cycle shown in Figure 2.2, from which the cycles of large steam power plants are derived.

In the simple Rankine cycle, steam flows to a turbine, where part of its energy is converted to mechanical energy that is transmitted by rotating shaft to drive an electrical generator. The reduced-energy steam flowing out of the turbine condenses to liquid water in the *condenser*. A feedwater pump returns the condensed liquid (*condensate*) to the steam generator. The heat rejected from the steam entering the condenser is transferred to a separate cooling water loop that in turn delivers the rejected energy to a neighboring lake or river or to the atmosphere.



FIGURE 2.1 A modern coal-burning steam power plant nearing completion. Coal is transported by conveyor from the storage pile to the crusher building at lower right, to silos visible on the side of the steam generator at the far end of the conveyor. The turbine room is to the left of the steam generator. Cooling towers at the extreme right cool the condenser cooling water. A 1970-vintage natural-gas-burning plant is visible in the left rear. (Courtesy of the Public Service Company of Oklahoma.)

As a result of the conversion of much of its thermal energy into mechanical energy, or work, steam leaves the turbine at a pressure and temperature well below the turbine entrance (throttle) values. At this point the steam could be released into the atmosphere. But since water resources are seldom adequate to allow the luxury of one-time use, and because water purification of a continuous supply of fresh feedwater is costly, steam power plants normally utilize the same pure water over and over again. We usually say that the working fluid (water) in the plant operates in a cycle or undergoes of cyclic process, as indicated in Figure 2.2. In order to return the steam to the high-pressure of the steam generator to continue the cycle, the low- pressure steam leaving the turbine at state 2 is first condensed to a liquid at state 3 and then pressurized in a pump to state 4. The high pressure liquid water is then ready for its next pass through the steam generator to state 1 and around the Rankine cycle again.

The steam generator and condenser both may be thought of as types of heat exchangers, the former with hot combustion gases flowing on the outside of water-

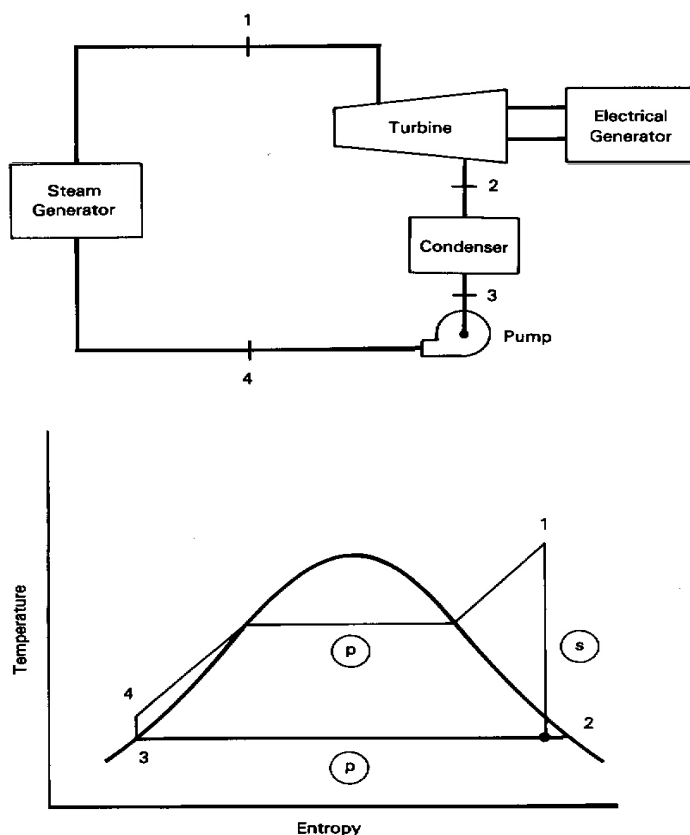

FIGURE 2.2 Rankine-cycle flow and T-s diagrams.

filled tubes, and the latter with external cooling water passing through tubes on which the low-pressure turbine exhaust steam condenses. In a well-designed heat exchanger, both fluids pass through with little pressure loss. Therefore, as an ideal, it is common to think of steam generators and condensers as operating with their fluids at unchanging pressures.

It is useful to think of the Rankine cycle as operating between two fixed pressure levels, the pressure in the steam generator and pressure in the condenser. A pump provides the pressure increase, and a turbine provides the controlled pressure drop between these levels.

Looking at the overall Rankine cycle as a system (Figure 2.2), we see that work is delivered to the surroundings (the electrical generator and distribution system) by the turbine and extracted from the surroundings by a pump (driven by an electric motor or a small steam turbine). Similarly, heat is received from the surroundings (combustion gas) in the steam generator and rejected to cooling water in the condenser.

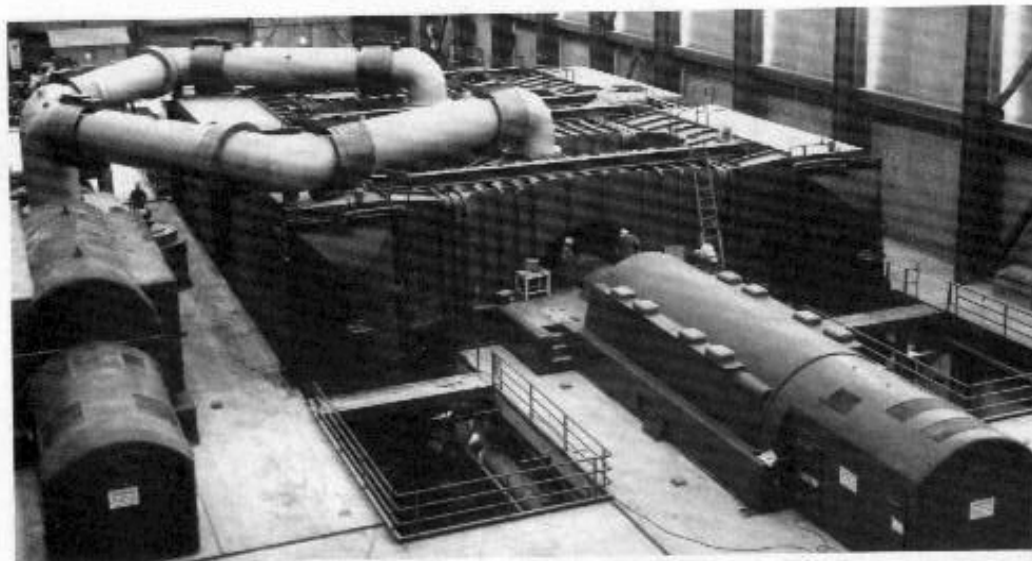

FIGURE 2.3 Steam turbines, generator, and condenser at TVA Bull Run plant. Large overhead steam lines connect high- and low-pressure turbines. (Courtesy of the Tennessee Valley Authority.)

At the start of the twentieth century reciprocating steam engines extracted thermal energy from steam and converted linear reciprocating motion to rotary motion, to provide shaft power for industry. Today, highly efficient steam turbines, such as shown in Figure 2.3, convert thermal energy of steam directly to rotary motion. Eliminating the intermediate step of conversion of thermal energy into the linear motion of a piston was an important factor in the success of the steam turbine in electric power generation. The resulting high rotational speed, reliability, and power output of the turbine and the development of electrical distribution systems allowed the centralization of power production in a few large plants capable of serving many industrial and residential customers over a wide geographic area.

The final link in the conversion of chemical energy to thermal energy to mechanical energy to electricity is the electrical generator. The rotating shaft of the electrical generator usually is directly coupled to the turbine drive shaft. Electrical windings attached to the rotating shaft of the generator cut the lines of force of the stator windings, inducing a flow of alternating electrical current in accordance with Faraday's Law. In the United States, electrical generators turn at a multiple of the generation frequency of 60 cycles per second, usually 1800 or 3600 rpm. Elsewhere, where 50 cycles per second is the standard frequency, the speed of 3000 rpm is common. Through transformers at the power plant, the voltage is increased to several hundred thousand volts for transmission to distant distribution centers. At the distribution centers as well as neighborhood electrical transformers, the electrical potential is reduced, ultimately to the 110- and 220-volt levels used in homes and industry.

Since at present there is no economical way to store the large quantities of electricity produced by a power plant, the generating system must adapt, from moment to moment, to the varying demands for electricity from its customers. It is therefore important that a power company have both sufficient generation capacity to reliably satisfy the maximum demand and generation equipment capable of adapting to varying load.

2.3 Rankine-Cycle Analysis

In analyses of heat engine cycles it is usually assumed that the components of the engine are joined by conduits that allow transport of the working fluid from the exit of one component to the entrance of the next, with no intervening state change. It will be seen later that this simplification can be removed when necessary.

It is also assumed that all flows of mass and energy are steady, so that the steady state conservation equations are applicable. This is appropriate to most situations because power plants usually operate at steady conditions for significant lengths of time. Thus, transients at startup and shutdown are special cases that will not be considered here.

Consider again the Rankine cycle shown in Figure 2.2. Control of the flow can be exercised by a throttle valve placed at the entrance to the turbine (state 1). Partial valve closure would reduce both the steam flow to the turbine and the resulting power output. We usually refer to the temperature and pressure at the entrance to the turbine as *throttle conditions*. In the ideal Rankine cycle shown, steam expands adiabatically and reversibly, or isentropically, through the turbine to a lower temperature and pressure at the condenser entrance. Applying the steady-flow form of the First Law of Thermodynamics [Equation (1.10)] for an isentropic turbine we obtain:

$$q = 0 = h_2 - h_1 + w_t \quad [\text{Btu/lb}_m \mid \text{kJ/kg}]$$

where we neglect the usually small kinetic and potential energy differences between the inlet and outlet. This equation shows that the turbine work per unit mass passing through the turbine is simply the difference between the entrance enthalpy and the lower exit enthalpy:

$$w_t = h_1 - h_2 \quad [\text{Btu/lb}_m \mid \text{kJ/kg}] \quad (2.1)$$

The power delivered by the turbine to an external load, such as an electrical generator, is given by the following:

$$\text{Turbine Power} = m_s w_t = m_s (h_1 - h_2) \quad [\text{Btu/hr} \mid \text{kW}]$$

where m_s [$\text{lb}_m/\text{hr} \mid \text{kg/s}$] is the mass flow of steam through the power plant.

Applying the steady-flow First Law of Thermodynamics to the steam generator, we see that shaft work is zero and thus that the steam generator heat transfer is

$$q_a = h_1 - h_4 \quad [\text{Btu/lb}_m \mid \text{kJ/kg}] \quad (2.2)$$

The condenser usually is a large shell-and-tube heat exchanger positioned below or adjacent to the turbine in order to directly receive the large flow rate of low-pressure turbine exit steam and convert it to liquid water. External cooling water is pumped through thousands of tubes in the condenser to transport the heat of condensation of the steam away from the plant. On leaving the condenser, the condensed liquid (called *condensate*) is at a low temperature and pressure compared with throttle conditions. Continued removal of low-specific-volume liquid formed by condensation of the high-specific-volume steam may be thought of as creating and maintaining the low pressure in the condenser. The phase change in turn depends on the transfer of heat released to the external cooling water. Thus the rejection of heat to the surroundings by the cooling water is essential to maintaining the low pressure in the condenser. Applying the steady-flow First Law of Thermodynamics to the condensing steam yields:

$$q_c = h_3 - h_2 \quad [\text{Btu/lb}_m \mid \text{kJ/kg}] \quad (2.3)$$

The condenser heat transfer q_c is negative because $h_2 > h_3$. Thus, consistent with sign convention, q_c represents an outflow of heat from the condensing steam. This heat is absorbed by the cooling water passing through the condenser tubes. The condenser-cooling-water temperature rise and mass-flow rate m_c are related to the rejected heat by:

$$m_s |q_c| = m_c c_{\text{water}} (T_{\text{out}} - T_{\text{in}}) \quad [\text{Btu/hr} \mid \text{kW}]$$

where c_{water} is the heat capacity of the cooling water [Btu/lb_m-R | kJ/kg-K]. The condenser cooling water may be drawn from a river or a lake at the temperature T_{in} and returned downstream at T_{out} , or it may be circulated through cooling towers where heat is rejected from the cooling water to the atmosphere.

We can express the condenser heat transfer in terms of an overall heat transfer coefficient, U , the mean cooling water temperature, $T_m = (T_{\text{out}} + T_{\text{in}})/2$, and the condensing temperature T_3 :

$$m_s |q_c| = UA(T_3 - T_m) \quad [\text{Btu/hr} \mid \text{kJ/s}]$$

It is seen for given heat rejection rate, the condenser size represented by the tube surface area A depends inversely on (a) the temperature difference between the condensing steam and the cooling water, and (b) the overall heat-transfer coefficient.

For a fixed average temperature difference between the two fluids on opposite sides of the condenser tube walls, the temperature of the available cooling water controls the condensing temperature and hence the pressure of the condensing steam.

Therefore, the colder the cooling water, the lower the minimum temperature and pressure of the cycle and the higher the thermal efficiency of the cycle.

A pump is a device that moves a liquid from a region of low pressure to one of high pressure. In the Rankine cycle the condenser condensate is raised to the pressure of the steam generator by *boiler feed pumps*, BFP. The high-pressure liquid water entering the steam generator is called *feedwater*. From the steady-flow First Law of Thermodynamics, the work and power required to drive the pump are:

$$w_p = h_3 - h_4 \quad [\text{Btu/lb}_m \mid \text{kJ/kg}] \quad (2.4)$$

and

$$\text{Pump Power} = m_s w_p = m_s (h_3 - h_4) \quad [\text{Btu/hr} \mid \text{kW}]$$

where the negative values resulting from the fact that $h_4 > h_3$ are in accordance with the thermodynamic sign convention, which indicates that work and power must be supplied to operate the pump.

The net power delivered by the Rankine cycle is the difference between the turbine power and the magnitude of the pump power. One of the significant advantages of the Rankine cycle is that the pump power is usually quite small compared with the turbine power. This is indicated by the *work ratio*, w_t / w_p , which is large compared with one for Rankine cycle. As a result, the pumping power is sometimes neglected in approximating the Rankine cycle net power output.

It is normally assumed that the liquid at a pump entrance is saturated liquid. This is usually the case for power-plant feedwater pumps, because on the one hand subcooling would increase the heat addition required in the steam generator, and on the other the introduction of steam into the pump would cause poor performance and destructive, unsteady operation. The properties of the pump inlet or condenser exit (state 3 in Figure 2.2) therefore may be obtained directly from the saturated-liquid curve at the (usually) known condenser pressure.

The properties for an isentropic pump discharge at state 4 could be obtained from a subcooled-water property table at the known inlet entropy and the throttle pressure. However, such tables are not widely available and usually are not needed. The *enthalpy of a subcooled state* is commonly approximated by the enthalpy of the saturated-liquid evaluated at the temperature of the subcooled liquid. This is usually quite accurate because the enthalpy of a liquid is almost independent of pressure. An accurate method for estimating the pump enthalpy rise and the pump work is given later (in Example 2.3).

A measure of the effectiveness of an energy conversion device is its *thermal efficiency*, which is defined as the ratio of the cycle net work to the heat supplied from external sources. Thus, by using Equations (2.1), (2.2), and (2.4) we can express the ideal Rankine-cycle thermal efficiency in terms of cycle enthalpies as:

$$\eta_{\text{th}} = (h_1 - h_2 + h_3 - h_4)/(h_1 - h_4) \quad [\text{dl}] \quad (2.5)$$

In accordance with the Second Law of Thermodynamics, the Rankine cycle efficiency must be less than the efficiency of a Carnot engine operating between the same temperature extremes. As with the Carnot-cycle efficiency, Rankine-cycle efficiency improves when the average heat-addition temperature increases and the heat-rejection temperature decreases. Thus cycle efficiency may be improved by increasing turbine inlet temperature and decreasing the condenser pressure (and thus the condenser temperature).

Another measure of efficiency commonly employed by power plant engineers is the *heat rate*, that is, the ratio of the rate of heat addition in conventional heat units to the net power output in conventional power units. Because the rate of heat addition is proportional to the fuel consumption rate, the heat rate is a measure of fuel utilization rate per unit of power output. In the United States, the rate of heat addition is usually stated in Btu/hr, and electrical power output in kilowatts, resulting in heat rates being expressed in Btu/kW-hr. The reader should verify that the heat rate in English units is given by the conversion factor, 3413 Btu/kW-hr, divided by the cycle thermal efficiency as a decimal fraction, and that its value has a magnitude of the order of 10,000 Btu/kW-hr. In the SI system of units, the heat rate is usually expressed in kJ/kW-hr, is given by 3600 divided by the cycle efficiency as a decimal fraction, and is of the same order of magnitude as in the English system. It is evident that a low value of heat rate represents high thermal efficiency and is therefore desirable.

EXAMPLE 2.1

An ideal Rankine cycle (see Figure 2.2) has a throttle state of 2000 psia/1000°F and condenser pressure of 1 psia. Determine the temperatures, pressures, entropies, and enthalpies at the inlets of all components, and compare the thermal efficiency of the cycle with the relevant Carnot efficiency. Neglect pump work. What is the quality of the steam at the turbine exit?

Solution

The states at the inlets and exits of the components, following the notation of Figure 2.2, are listed in the following table. The enthalpy and entropy of state 1 may be obtained directly from tables or charts for superheated steam (such as those in Appendices B and C) at the throttle conditions. A Mollier chart is usually more convenient than tables in dealing with turbine inlet and exit conditions.

For an ideal isentropic turbine, the entropy is the same at state 2 as at state 1. Thus state 2 may be obtained from the throttle entropy ($s_2 = s_1 = 1.5603 \text{ Btu/lb}_m\text{-R}$) and the condenser pressure (1 psia). In general, this state may be in either the superheated-steam region or the mixed-steam-and-liquid region of the Mollier and T-s diagrams. In the present case it is well into the mixed region, with a temperature of 101.74°F and an enthalpy of 871 Btu/lb_m.

The enthalpy, $h_3 = 69.73 \text{ Btu/lb}_m$, and other properties at the pump inlet are obtained from saturated-liquid tables, at the condenser pressure. The steady-flow First Law of Thermodynamics, in the form of Equation (2.4), indicates that neglecting isentropic pump work is equivalent to neglecting the pump enthalpy rise. Thus in this case Equation (2.4) implies that h_3 and h_4 shown in Figure (2.2) are almost equal. Thus we take $h_4 = h_3$ as a convenient approximation.

State	Temperature (°F)	Pressure (psia)	Entropy (Btu/lb _m -°R)	Enthalpy (Btu/lb _m)
1	1000.0	2000	1.5603	1474.1
2	101.74	1	1.5603	871.0
3	101.74	1	0.1326	69.73
4	101.74	2000	0.1326	69.73

The turbine work is

$$h_1 - h_2 = 1474.1 - 871 = 603.1 \text{ Btu/lb}_m.$$

The heat added in the steam generator is

$$h_1 - h_4 = 1474.1 - 69.73 = 1404.37 \text{ Btu/lb}_m.$$

The thermal efficiency is the net work per heat added = $603.1/1404.37 = 0.4294$ (42.94%). This corresponds to a heat rate of $3413/0.4294 = 7946 \text{ Btu/kW-hr}$. As expected, the efficiency is significantly below the value of the Carnot efficiency of $1 - (460 + 101.74)/(460 + 1000) = 0.6152$ (61.52%), based on a source temperature of T_1 and a sink temperature of T_3 .

The quality of the steam at the turbine exit is

$$(s_2 - s_l)/(s_v - s_l) = (1.5603 - 0.1326)/(1.9781 - 0.1326) = 0.7736$$

Here v and l indicate saturated vapor and liquid states, respectively, at pressure p_2 . Note that the quality could also have been obtained from the Mollier chart for steam as $1 - M$, where M is the steam moisture fraction at entropy s_2 and pressure p_2 .

Example 2-2

If the throttle mass-flow is $2,000,000 \text{ lb}_m/\text{hr}$ and the cooling water enters the condenser at 60°F , what is the power plant output in Example 2.1? Estimate the cooling-water mass-flow rate.

Solution: The power output is the product of the throttle mass-flow rate and the power plant net work. Thus

$$\text{Power} = (2 \times 10^6)(603.1) = 1.206 \times 10^9 \text{ Btu/hr}$$

or

$$\text{Power} = 1.206 \times 10^9 / 3413 = 353,413 \text{ kW.}$$

The condenser heat-transfer rate is

$$m_s q_c = m_s (h_3 - h_2) = 2,000,000 \times (69.73 - 871) = -1.603 \times 10^9 \text{ Btu/hr}$$

The condensing temperature, $T_3 = 101.74^\circ\text{F}$, is the upper bound on the cooling water exit temperature. Assuming that the cooling water enters at 60°F and leaves at 95°F , the cooling-water flow rate is given by

$$m_c = m_s |q_c| / [c_{\text{water}}(T_{\text{out}} - T_{\text{in}})] = 1.603 \times 10^9 / [(1)(95 - 60)] = 45.68 \times 10^6 \text{ lb}_m/\text{hr}$$

A higher mass-flow rate of cooling water would allow a smaller condenser cooling-water temperature rise and reduce the required condenser-heat-transfer area at the expense of increased pumping power.

2.4 Deviations from the Ideal – Component Efficiencies

In a power plant analysis it is sometimes necessary to account for non-ideal effects such as fluid friction, turbulence, and flow separation in components otherwise assumed to be reversible. Decisions regarding the necessity of accounting for these effects are largely a matter of experience built on familiarity with the magnitudes of the effects, engineering practices, and the uses of the calculated results.

Turbine

In the case of an *adiabatic turbine* with flow irreversibilities, the steady-flow First Law of Thermodynamics gives the same symbolic result as for the isentropic turbine in Equation (2.1), i.e.,

$$w_t = h_1 - h_2 \quad [\text{Btu/lb} \mid \text{kJ/kg}] \quad (2.6)$$

except that here h_2 represents the actual exit enthalpy and w_t is the actual work of an adiabatic turbine where real effects such as flow separation, turbulence, irreversible internal heat transfers, and fluid friction exist.

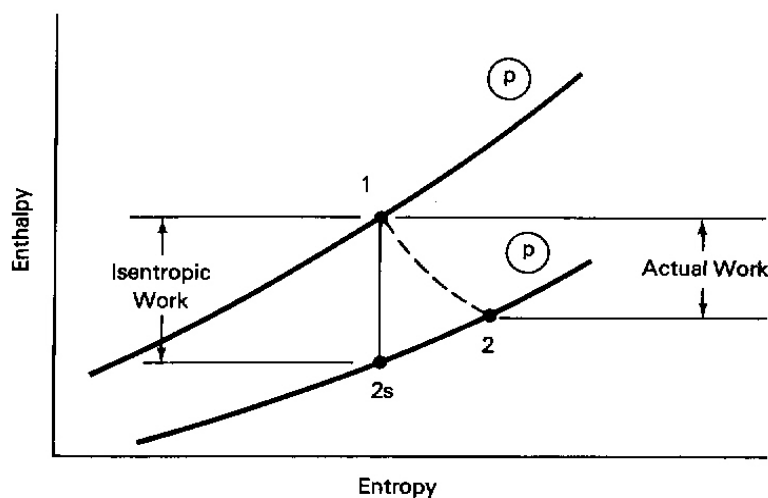

FIGURE 2.4 Turbine efficiency.

An efficiency for a real turbine, known as the *isentropic efficiency*, is defined as the ratio of the actual shaft work to the shaft work for an isentropic expansion between the same inlet state and exit pressure level. Based on the notation of Figure 2.4, we see that the turbine efficiency is:

$$\eta_{turb} = (h_1 - h_2)/(h_1 - h_{2s}) \quad [dl] \quad (2.7)$$

where h_{2s} , the isentropic turbine-exit enthalpy, is the enthalpy evaluated at the turbine inlet entropy and the exit pressure. For the special case of an isentropic turbine, $h_2 = h_{2s}$ and the efficiency becomes 1. Note how state 2 and the turbine work change in Figure 2.4 as the efficiency increases toward 1. The diagram shows that the difference between the isentropic and actual work, $h_2 - h_{2s}$, represents work lost due to irreversibility. Turbine isentropic efficiencies in the low 90% range are currently achievable in well-designed machines.

Normally in solving problems involving turbines, the turbine efficiency is known from manufacturers' tests, and the inlet state and the exhaust pressure are specified. State 1 and p_2 determine the isentropic discharge state 2s using the steam tables. The actual turbine-exit enthalpy can then be calculated from Equation (2.7). Knowing both p_2 and h_2 , we can then fully identify state 2 and account for real turbine behavior in any cycle analysis.

Pump

Work must be supplied to a pump to move liquid from a low pressure to a high pressure. Some of the work supplied is lost due to irreversibilities. Ideally the remaining effective work to raise the pressure is necessarily less than that supplied. In order for

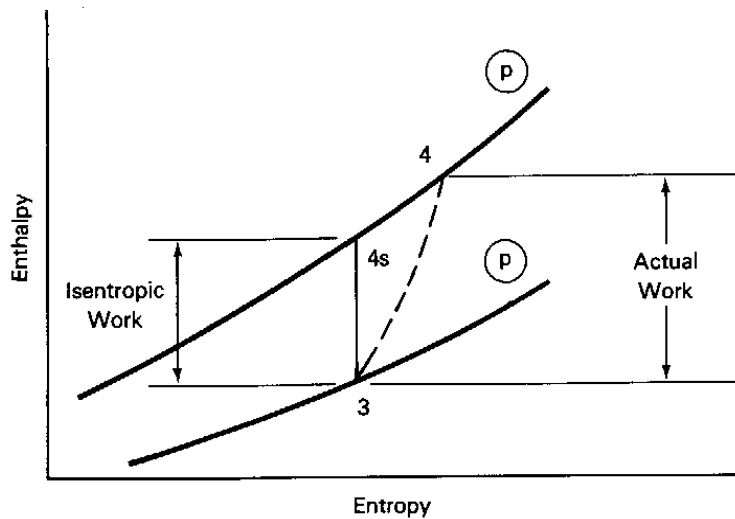

FIGURE 2.5 Pump efficiency.

the efficiency of a pump to be less than or equal to 1, it is defined in inverse fashion to turbine efficiency. That is, pump efficiency is the ratio of the isentropic work to the actual work input when operating between two given pressures. Applying Equation (2.4) and the notation of Figure (2.5), the isentropic pump work, $w_{ps} = h_3 - h_{4s}$, and the *pump isentropic efficiency* is

$$\eta_{pump} = w_{ps} / w_p = (h_{4s} - h_3) / (h_4 - h_3) \quad [dl] \quad (2.8)$$

Note the progression of exit states that would occur in Figure 2.5 as pump efficiency increases for a fixed inlet state and exit pressure. It is seen that the pump lost work, given by $h_4 - h_{4s}$ decreases and that the actual discharge state approaches the isentropic discharge state.

States 4 and 4s are usually subcooled liquid states. As a first approximation their enthalpies may be taken to be the saturated liquid enthalpy at T_3 . More accurate approximations for these enthalpies may be obtained by applying the First Law for a closed system undergoing a reversible process, Equation (1.8): $Tds = dh - vdp$. For an isentropic process it follows that $dh = vdp$. Because a liquid is almost incompressible, its specific volume, v , is almost independent of pressure. Thus, using the notation of Figure 2.5, integration with constant specific volume yields

$$h_{4s} = h_3 + v_3 (p_4 - p_3) \quad [\text{Btu/lb}_m \mid \text{kJ/kg}]$$

where a knowledge of state 3 and p_4 determines h_{4s} .

Using Equation (2.8), and without consulting tables for subcooled water, we can then calculate the pump work from

$$w_p = v_3(p_3 - p_4)/\eta_p \quad [\text{ft}\cdot\text{lb}_f/\text{lb}_m \mid \text{kN}\cdot\text{m}/\text{kg}] \quad (2.9)$$

Note that the appropriate conversion factors must be applied for dimensional consistency in Equation (2.9).

EXAMPLE 2.3

Calculate the actual work and the isentropic and actual discharge enthalpies for an 80% efficient pump with an 80°F saturated-liquid inlet and an exit pressure of 3000 psia.

Solution

From the saturated-liquid tables, for 80°F, the pump inlet conditions are 0.5068 psia, 48.037 Btu/lb_m, and 0.016072 ft³/lb_m.

Using Equation (2.9), we find that the pump work is

$$w_p = [0.016072(0.5068 - 3000)(144)]/0.8 = -8677 \text{ ft}\cdot\text{lb}_f/\text{lb}_m$$

or

$$w_p = -8677/778 = -11.15 \text{ Btu}/\text{lb}_m$$

Note the importance of checking units here.

The actual discharge enthalpy is

$$h_4 = h_3 - w_p = 48.037 - (-11.15) = 59.19 \text{ Btu}/\text{lb}_m$$

and the isentropic discharge enthalpy is

$$h_{4s} = h_3 - \eta_p w_p = 48.037 - (0.8)(-11.15) = 56.96 \text{ Btu}/\text{lb}_m$$

EXAMPLE 2.4

What is the turbine work, the net work, the work ratio, and the cycle thermal efficiency for the conditions of Example 2.1 if the turbine efficiency is 90% and the pump efficiency is 85%? What is the turbine exit quality?

Solution

By the definition of isentropic efficiency, the turbine work is 90% of the isentropic turbine work = (0.9)(603.1) = 542.8 Btu/lb_m.

By using Equation (2.9), the isentropic pump work is

$$[(0.01614)(1 - 2000)(144)] / 778 = -5.97 \text{ Btu}/\text{lb}_m$$

The actual pump work is then $-5.97/0.85 = -7.03$ Btu/lb_m and the work ratio is $542.8/| -7.03| = 77.2$

The cycle net work is $w_t + w_p = 542.8 - 7.03 = 535.8$ Btu/lb_m.

Applying the steady-flow First Law of Thermodynamics to the pump, we get the enthalpy entering the steam generator to be

$$h_4 = h_3 - w_p = 69.73 - (-7.03) = 76.76 \text{ Btu/lb}_m.$$

The steam-generator heat addition is then reduced to $1474.1 - 76.76 = 1397.3$ Btu/lb_m and the cycle efficiency is $535.8/1397.3 = 0.383$. Study of these examples shows that the sizable reduction in cycle efficiency from that in Example 2.1 is largely due to the turbine inefficiency, not to the neglect of pump work.

From Equation (2.6), the true turbine exit enthalpy is the difference between the throttle enthalpy and actual turbine work = $1474.1 - 542.8 = 931.3$ Btu/lb_m.

The quality is then $x = (h_2 - h_1)/(h_v - h_1) = (931.3 - 69.73)/(1105.8 - 69.73) = 0.832$.

Thus the turbine inefficiency increases the turbine exhaust quality over the isentropic turbine value of 0.774.

2.5 Reheat and Reheat Cycles

A common modification of the Rankine cycle in large power plants involves interrupting the steam expansion in the turbine to add more heat to the steam before completing the turbine expansion, a process known as *reheat*. As shown in Figure 2.6, steam from the high-pressure (HP) turbine is returned to the reheat section of the steam generator through the "cold reheat" line. There the steam passes through heated tubes which restore it to a temperature comparable to the throttle temperature of the high pressure turbine. The reenergized steam then is routed through the "hot reheat" line to a low-pressure turbine for completion of the expansion to the condenser pressure.

Examination of the T-s diagram shows that reheat increases the area enclosed by the cycle and thus increases the net work of the cycle by virtue of the cyclic integral, Equation (1.3). This is significant, because for a given design power output higher net work implies lower steam flow rate. This, in turn, implies that smaller plant components may be used, which tends to reduce the initial plant cost and to compensate for added costs due to the increased complexity of the cycle.

Observe from Figure 2.6 that the use of reheat also tends to increase the average temperature at which heat is added. If the low-pressure turbine exhaust state is superheated, the use of reheat may also increase the average temperature at which heat is rejected. The thermal efficiency may therefore increase or decrease, depending on specific cycle conditions. Thus the major benefits of reheat are increased net work,

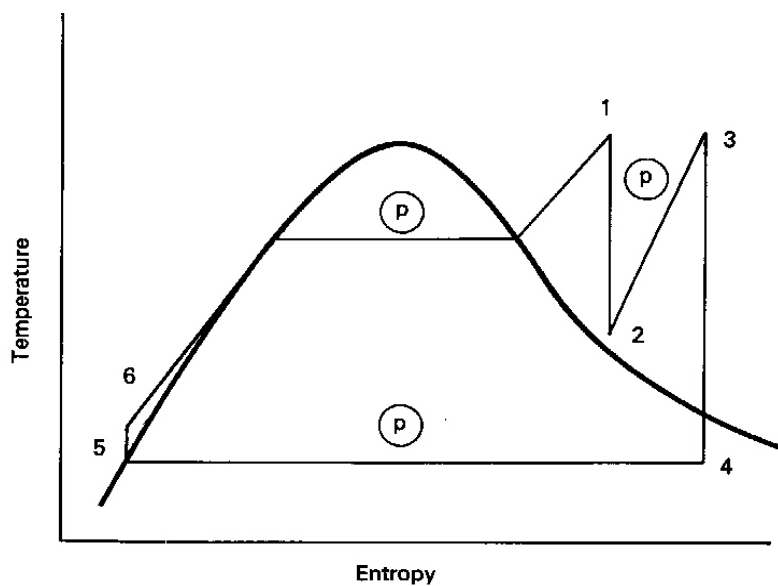
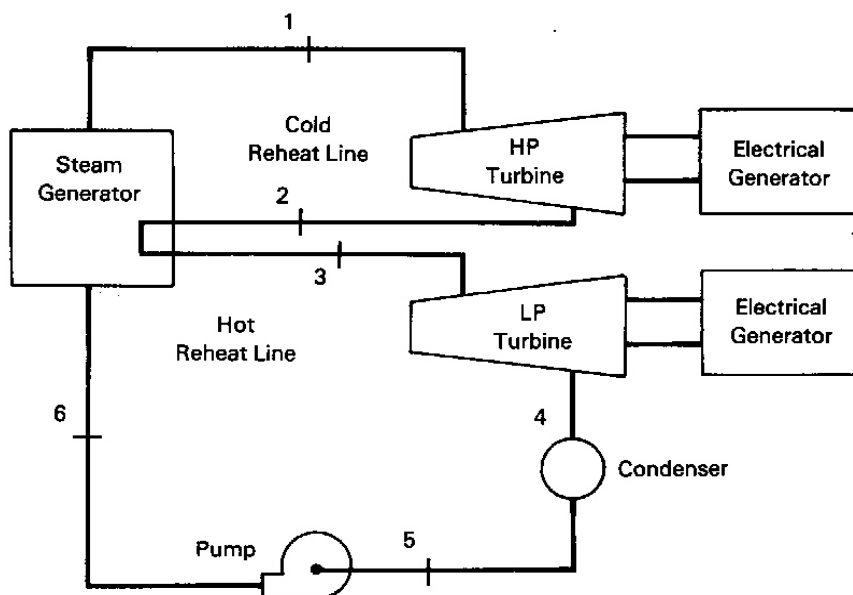

FIGURE 2.6 Rankine reheat cycle.

drying of the turbine exhaust (discussed further later), and the possibility of improved cycle efficiency.

Note that the net work of the reheat cycle is the algebraic sum of the work of the two turbines and the pump work. Note also that the total heat addition is the sum of the heat added in the feedwater and reheat passes through the steam generator. Thus the

thermal efficiency of the reheat cycle is:

$$\eta_{th} = \frac{(h_1 - h_2) + (h_3 - h_4) + (h_5 - h_6)}{(h_1 - h_6) + (h_3 - h_2)} \quad [\text{dl}] \quad (2.10)$$

Relations such as this illustrate the wisdom of learning to analyze cycles using definitions and applying fundamentals to components rather than memorizing equations for special cases such as Equation (2.5) for the efficiency of the simple Rankine cycle.

Note that the inclusion of reheat introduces a third pressure level to the Rankine cycle. Determination of a suitable reheat pressure level is a significant design problem that entails a number of considerations. The cycle efficiency, the net work, and other parameters will vary with reheat pressure level for given throttle and condenser conditions. One of these may be numerically optimized by varying reheat pressure level while holding all other design conditions constant.

Reheat offers the ability to limit or eliminate moisture at the turbine exit. The presence of more than about 10% moisture in the turbine exhaust can cause erosion of blades near the turbine exit and reduce energy conversion efficiency. Study of Figure 2.6 shows that reheat shifts the turbine expansion process away from the two-phase region and toward the superheat region of the T-s diagram, thus drying the turbine exhaust.

EXAMPLE 2.5

Reanalyze the cycle of Example 2.1 (2000 psia/1000°F/1 psia) with reheat at 200 psia included. Determine the quality or degree of superheat at the exits of both turbines. Assume that reheat is to the HP turbine throttle temperature.

Solution

Referring to Figure 2.6, we see that the properties of significant states are the following:

State	Temperature (°F)	Pressure (psia)	Entropy (Btu/lb _m -°R)	Enthalpy (Btu/lb _m)
1	1000.0	2000	1.5603	1474.1
2	400.0	200	1.5603	1210.0
3	1000.0	200	1.84	1527.0
4	101.74	1	1.84	1028.0
5	101.74	1	0.1326	69.73
6	101.74	2000	0.1326	69.73

Properties here are obtained from the steam tables and the Mollier chart as follows:

1. The enthalpy and entropy at state 1 are read from the superheated-steam tables at the given throttle temperature and pressure.
2. State 2 is evaluated from the Mollier diagram at the given reheat pressure and the same entropy as in state 1 for the isentropic turbine expansion.
3. Reheat at constant pressure $p_3 = p_2$ to the assumed throttle temperature $T_3 = T_1$ gives s_3 and h_3 . Normally, T_3 is assumed equal to T_1 unless otherwise specified.
4. The second turbine flow is also specified as isentropic with expansion at $s_4 = s_3$ to the known condenser pressure p_4 .
5. The condenser exit (pump entrance) state is assumed to be a saturated liquid at the known condenser pressure.
6. Pump work is neglected here. The steady-flow First Law then implies that $h_6 = h_5$, which in turn implies the $T_6 = T_5$.

The turbine work is the sum of the work of both turbines:
 $(1474.1 - 1210) + (1527 - 1028) = 763.1 \text{ Btu/lb}_m$.

The heat added in the steam generator feedwater and reheat passes is
 $(1474.1 - 69.73) + (1527 - 1210) = 1721.4 \text{ Btu/lb}_m$.

The thermal efficiency then is $763.1/1721.4 = 0.443$, or 44.3%.

Both the net work and the cycle efficiency are higher than in the simple Rankine cycle case of Example 2.1. From the Mollier chart in Appendix B it is readily seen that state 2 is superheated, with $400 - 381.8 = 18.2$ Fahrenheit degrees of superheat; and state 4 is wet steam, with 7.4% moisture, or 0.926 (92.6%) quality. Thus the first turbine has no moisture and the second is substantially drier than 0.774 quality value in Example 2.1.

Reheat is an important feature of all large, modern fossil-fueled steam power plants. We now consider another key feature of these plants, but temporarily omit reheat, for the purpose of clarity.

2.6 Regeneration and Feedwater Heaters

The significant efficiency advantage of the Carnot cycle over the Rankine cycle is due to the fact that in the Carnot cycle all external heat addition is at a single high

temperature and all external heat rejection at a single low temperature. Examination of Figures 2.2 and 2.6 shows that heat addition in the steam generator takes place over a wide range of water temperature in both the simple and reheat Rankine cycles.

Presumably, the Rankine-cycle thermal efficiency could be improved by increasing the average water temperature at which heat is received. This could be accomplished by an internal transfer of heat from higher-temperature steam to low-temperature feedwater. An internal transfer of heat that reduces or eliminates low-temperature additions of external heat to the working fluid is known as *regeneration*.

Open Feedwater Heaters

Regeneration is accomplished in all large-scale, modern power plants through the use of feedwater heaters. A *feedwater heater* (FWH) is a heat exchanger in which the latent heat (and sometimes superheat) of small amounts of steam is used to increase the temperature of liquid water (feedwater) flowing to the steam generator. This provides the internal transfer of heat mentioned above.

An *open feedwater heater* is a FWH in which a small amount of steam mixes directly with the feedwater to raise its temperature. Steam drawn from a turbine for feedwater heating or other purposes is called *extraction steam*. Feedwater heaters in which extraction steam heats feedwater without fluid contact will be discussed later.

Consider the regenerative Rankine-cycle presented in Figure 2.7. The steam leaving the high-pressure (HP) turbine is split with a small part of the mass flow extracted to an open FWH and the major part of the flow passing to a low pressure (LP) turbine. The T-s diagram shows that steam entering the FWH at state 2 is at a higher temperature than the subcooled feedwater leaving the pump at state 5. When the two fluids mix in the FWH, the superheat and the heat of vaporization of the extraction steam are transferred to the feedwater, which emerges with the condensed extraction steam at a higher temperature, T_6 . It is assumed that all streams entering and leaving the FWH are the same pressure so that the mixing process occurs at constant pressure.

The T-s and flow diagrams show that heat from combustion gases in the steam generator need only raise the water temperature from T_7 to T_1 rather than from T_5 when extraction steam is used to heat the feedwater. The average temperature for *external* heat addition must therefore increase. Despite the reduced flow rate through the low-pressure turbine, we will see by example that the thermal efficiency of the steam cycle is improved by the transfer of energy from the turbine extraction flow to the feedwater.

The analysis of cycles with feedwater heaters involves branching of steam flows. In Figure 2.7, for example, conservation of mass must be satisfied at the flow junction downstream of the high-pressure-turbine exit. Thus, assuming a mass flow of 1 at the HP turbine throttle and a steam mass-flow fraction, m_1 , through the feedwater heater, the low-pressure-turbine mass-fraction must be $1 - m_1$. Note that the latter flow passes through the condenser and pump and is reunited with the extraction flow, m_1 , in the FWH at state 6, where the exit-flow-rate fraction is again unity.

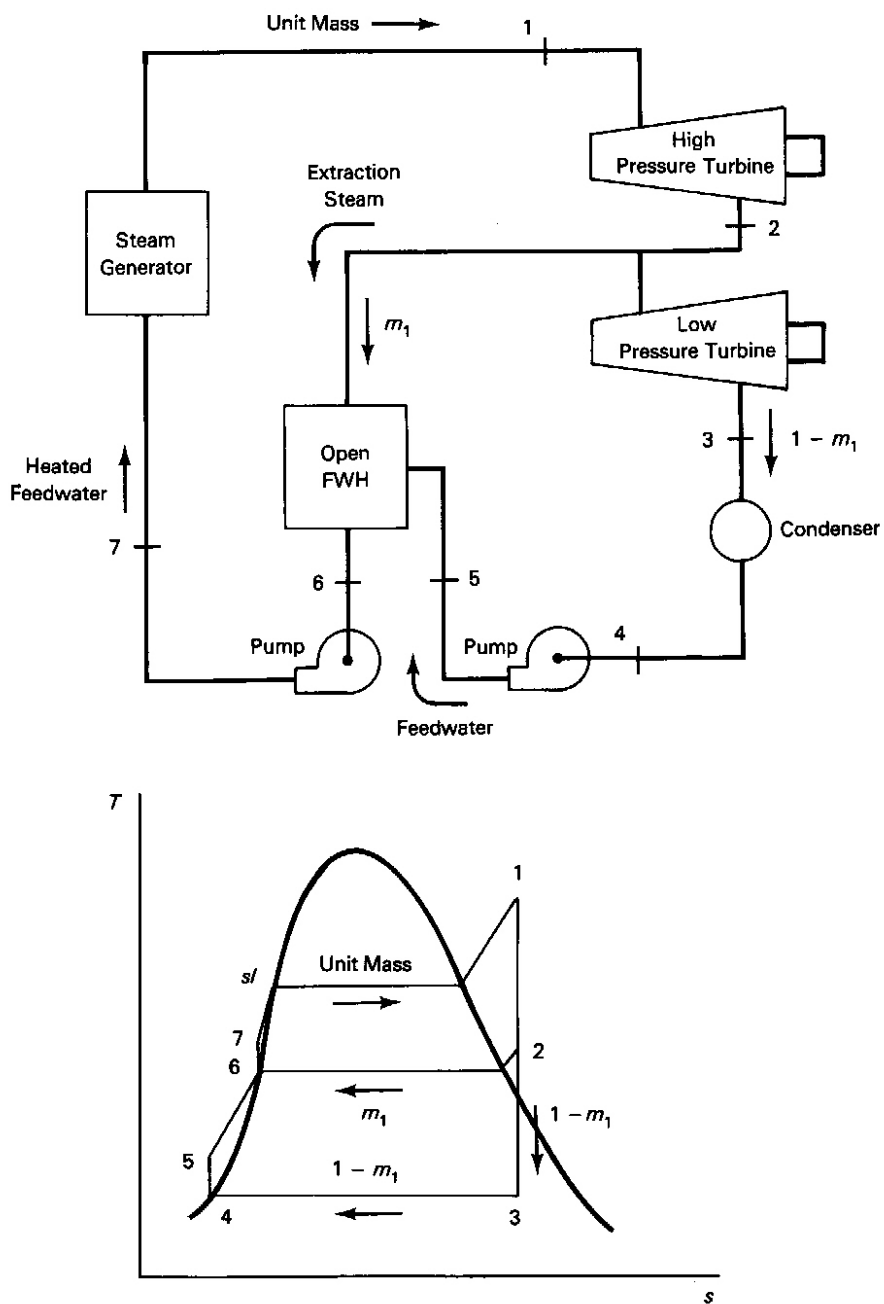

FIGURE 2.7 Regenerative Rankine cycle with a single open feedwater heater.

It will be seen later that it is common for more than one FWH to be used in a single power plant. When more than one FWH is present, mass flows m_1, m_2, \dots, m_n are defined for each of the n FWHs. Conservation of mass is used to relate these flows to

condenser flow rate and the reference throttle flow rate. This is accomplished by taking a mass flow of 1 at the high-pressure-turbine throttle as a reference, as in the case of a single FWH discussed above. After solving for each of the thermodynamic states and FWH mass fractions, actual mass flow rates are obtained as the products of the known (or assumed) throttle flow rate and FWH mass-flow fractions.

The function of feedwater heaters is to use the energy of extraction steam to reduce the addition of low-temperature external heat by raising the temperature of the feedwater before it arrives at the steam generator. Feedwater heaters are therefore insulated to avoid heat loss to the surroundings. Because the resulting heat loss is negligible compared with the energy throughflow, feedwater heaters are usually treated as adiabatic devices.

In order to avoid irreversibility associated with unrestrained expansion, *constant pressure mixing* of the streams entering the FWH is necessary. Returning to Figure 2.7, this implies that the pressures of the feedwater at state 5 and at the FWH exit state 6 are chosen to be the same as that of the extraction steam at state 2.

Note that, as with reheat, the inclusion of a FWH also introduces an additional pressure level into the Rankine cycle as seen in the T-s diagram. In the figure, the extraction pressure level, p_2 , is another parameter under the control of the designer. The extraction mass flow rate, m_1 , is in turn controlled by the designer's choice of p_2 . The mass-flow rate is determined by the physical requirement that the feedwater entering the FWH at state 5 increase in temperature to T_6 through absorption of the heat released by the condensing extraction steam. This is accomplished by applying the steady-flow First Law of Thermodynamics, using appropriate mass fractions, to the insulated open FWH:

$$q = 0 = (1)h_6 - m_1h_2 - (1 - m_1)h_5 + 0 \quad [\text{Btu/lb}_m \mid \text{kJ/kg}]$$

Every term in this equation has dimensions of energy per unit throttle mass, thus referring all energy terms to the mass-flow rate at the throttle of the high-pressure turbine. For example, the second term on the right is of the form:

$$\frac{\text{FWH Extraction mass}}{\text{Throttle mass}} \times \frac{\text{Enthalpy at state 2}}{\text{FWH Extraction mass}} = \frac{\text{Enthalpy at state 2}}{\text{Throttle mass}}$$

Similarly, the structure of the third term on the right has the significance of

$$\frac{\text{Pump mass}}{\text{Throttle mass}} \times \frac{\text{Enthalpy at state 5}}{\text{Pump mass}} = \frac{\text{Enthalpy at state 5}}{\text{Throttle mass}}$$

Solving for the extraction mass fraction, we obtain

$$m_1 = (h_6 - h_5) / (h_2 - h_5) \quad [\text{dl}] \quad (2.11)$$

For low extraction pressures, the numerator is usually small relative to the denominator, indicating a small extraction flow. The T-s diagram of Figure 2.7 shows that increasing the extraction pressure level increases both h_6 and h_2 . Thus, because the small numerator increases faster than the large denominator, we may reason, from Equation (2.11), that the extraction mass-flow fraction must increase as the extraction pressure level increases. This conforms to the physical notion that suggests the need for more and hotter steam to increase the feedwater temperature rise. While such intuitions are valuable, care should be exercised in accepting them without proof.

The total turbine work per unit throttle mass flow rate is the sum of the work of the turbines referenced to the throttle mass-flow rate. Remembering that $1 - m_1$ is the ratio of the low-pressure turbine mass flow to the throttle mass flow, we obtain:

$$w_t = (h_1 - h_2) + (1 - m_1)(h_2 - h_3) \quad [\text{Btu/lb}_m \mid \text{kJ/kg}] \quad (2.12)$$

The reader should examine the structure of each term of Equation (2.12) in the light of the previous discussion. Note that it is not important to remember these specific equations, but it is important to understand, and be able to apply, the reasoning by which they are obtained.

For a given throttle mass flow rate, m_{thr} [$\text{lb}_m/\text{s} \mid \text{kg/s}$], the total turbine power output is given by $m_{thr}w_t$ [$\text{Btu/s} \mid \text{kW}$].

We see in Figure 2.7 that the heat addition in the steam generator is reduced, due to extraction at pressure $p_6 = p_2$, by about $h_7 - h_5$ to

$$q_a = h_1 - h_7 \quad [\text{Btu/lb}_m \mid \text{kJ/kg}] \quad (2.13)$$

At the same time, the net work also decreases, but more slowly, so that the net effect is that the cycle efficiency increases with increased extraction.

EXAMPLE 2.6

Solve Example 2.1 (2000 psia /1000°F/1 psia) operating with an open feedwater heater at 200 psia.

Solution

Referring to Figure 2.7, we find that the properties of significant states are:

State	Temperature (°F)	Pressure (psia)	Entropy (Btu/lb _m -°R)	Enthalpy (Btu/lb _m)
1	1000.0	2000	1.5603	1474.1
2	400.0	200	1.5603	1210.0
3	101.74	1	1.5603	871.0
4	101.74	1	0.1326	69.73
5	101.74	200	0.1326	69.73
6	381.8	200	0.5438	355.5
7	381.8	2000	0.5438	355.5

States 1 through 4 are obtained in the same way as in earlier examples. Constant pressure mixing requires that $p_5 = p_6 = p_2$, the extraction pressure level. State 6, a pump entrance state, is assumed to be a saturated-liquid state as usual. Subcooled-liquid states are approximated, as before, consistent with the neglect of pump work.

The extraction mass fraction obtained by applying the steady-flow First Law of Thermodynamics to the FWH, Equation (2.11), is

$$m_1 = (355.5 - 69.73)/(1210 - 69.73) = 0.251.$$

The net work (neglecting pump work) by Equation (2.12), is then

$$w_n = (1474.1 - 1210) + (1 - 0.251)(1210 - 871) = 518.1 \text{ Btu/lb}_m$$

This may be compared with the simple-cycle net work of 603.1 Btu/lb_m.

The heat added in the steam generator by Equation (2.13) is

$$q_a = h_1 - h_7 = 1474.1 - 355.5 = 1118.6 \text{ Btu/lb}_m.$$

The resulting cycle efficiency is $\eta_{th} = 518.1/1118.6 = 0.463$, or 46.3%, a significantly higher value than the 42.94% for the corresponding simple Rankine cycle.

Note, however, that the LP-turbine exhaust quality is the same as for the simple Rankine cycle, an unacceptable 77.4%. This suggests that a combination of reheat and regeneration through feedwater heating may be desirable. We will investigate this possibility later after looking at closed feedwater heaters.

Closed Feedwater Heaters

We have seen that feedwater heating in open feedwater heaters occurs by mixing of extraction steam and feedwater. Feedwater heating also is accomplished in shell-and-

tube-type heat exchangers, where extraction steam does not mix with the feedwater. Normally, feedwater passes through banks of tubes whereas steam condenses on the outside of the tube surfaces in these heaters. Such heat exchangers are called *closed feedwater heaters*.

Pumped Condensate. Closed feedwater heaters normally are employed in two configurations in power plants. In the configuration shown in figure 2.8, condensate is pumped from the condenser through the FWH and the steam generator directly to the turbine along the path 4-5-8-9-1. Ideally, $p_5 = p_1$ assuming no pressure drop in the FWH and steam generator.

Note that if m_1 mass units of steam are extracted from the turbine for use in the FWH, only $1 - m_1$ units of feedwater pass through the condenser, pump, and the tubes of the FWH. The condensed extraction steam (condensate) emerging from the FWH at state 6 is pumped separately from $p_6 = p_2$ to throttle pressure $p_7 = p_1$, where it becomes part of the steam generator feedwater. The pumped condensate at state 7 thus mixes with the heated feedwater at state 8 to form the total feedwater flow at state 9. Constant pressure mixing ($p_7 = p_8 = p_9$) is required at this junction to avoid losses associated with uncontrolled flow expansion.

The enthalpy of the feedwater entering the steam generator can be determined by applying the steady-flow First Law of Thermodynamics to the junction of the feedwater and FWH streams:

$$h_9 = (1 - m_1)h_8 + m_1h_7 \quad [\text{Btu/lb}_m \mid \text{kJ/kg}]$$

As in the open FWH analysis, the extraction mass fraction depends on the choice of intermediate pressure p_2 and is obtained by applying the steady-flow First Law of Thermodynamics to the feedwater heater.

Throttled Condensate. The second closed FWH configuration is shown in Figure 2.9 where the FWH condensate drops in pressure from $p_6 = p_2$ through a trap into the condenser at pressure $p_7 = p_3 = p_4$. The trap allows liquid only to pass from the FWH at state 6 in a throttling process to state 7. As usual, it is assumed that the throttling process is adiabatic. The T-s diagram shows that the saturated liquid at state 6 flashes into a mixture of liquid and vapor in the condenser with no change in enthalpy, $h_7 = h_6$.

For this configuration, the closed FWH condensate mass-flow rate is equal to the extraction mass-flow rate. As a result, conservation of mass applied to the condenser shows that the mass-flow rate leaving the condenser and passing through the pump and FWH tubes is the same as the throttle mass-flow rate. The throttled-condensate, closed feedwater heater is the preferred configuration in power plants, because it is unnecessary for each FWH to have a condensate pump.

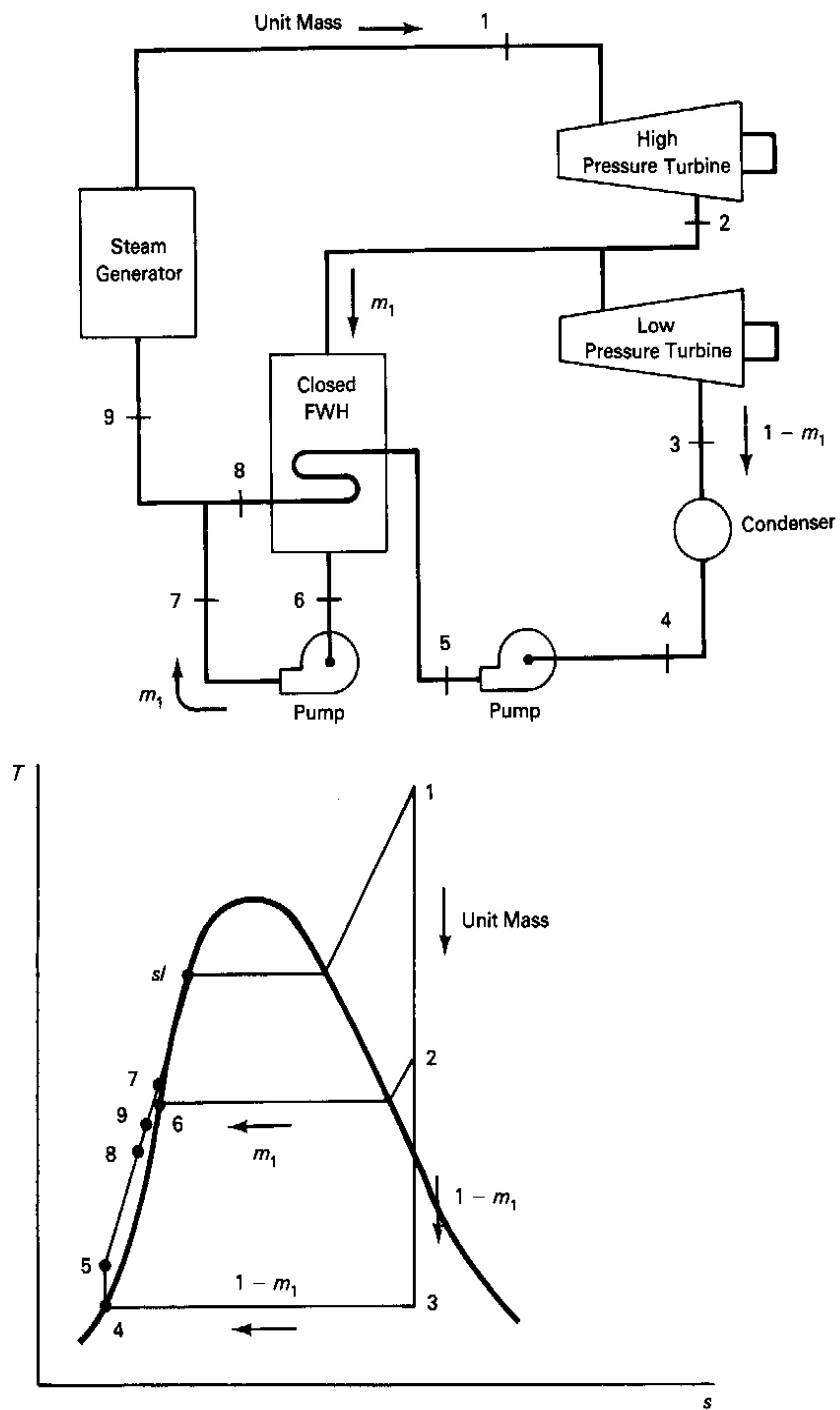

FIGURE 2.8 Regenerative Rankine cycle with closed feedwater heater and pumped condensate.

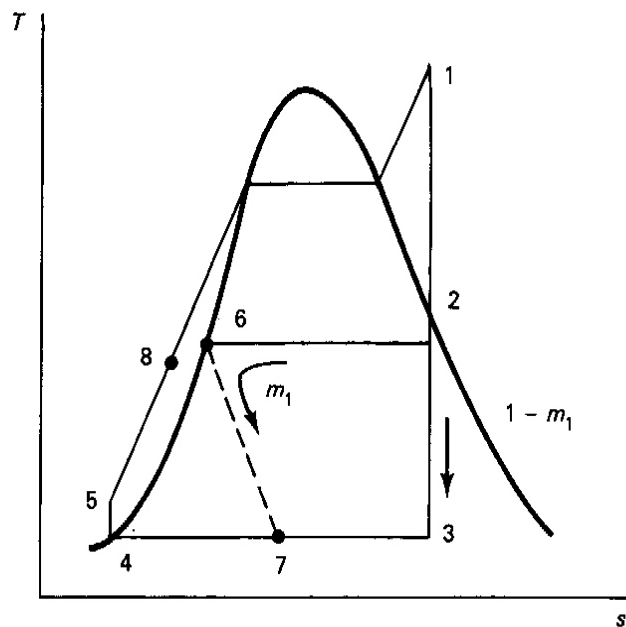
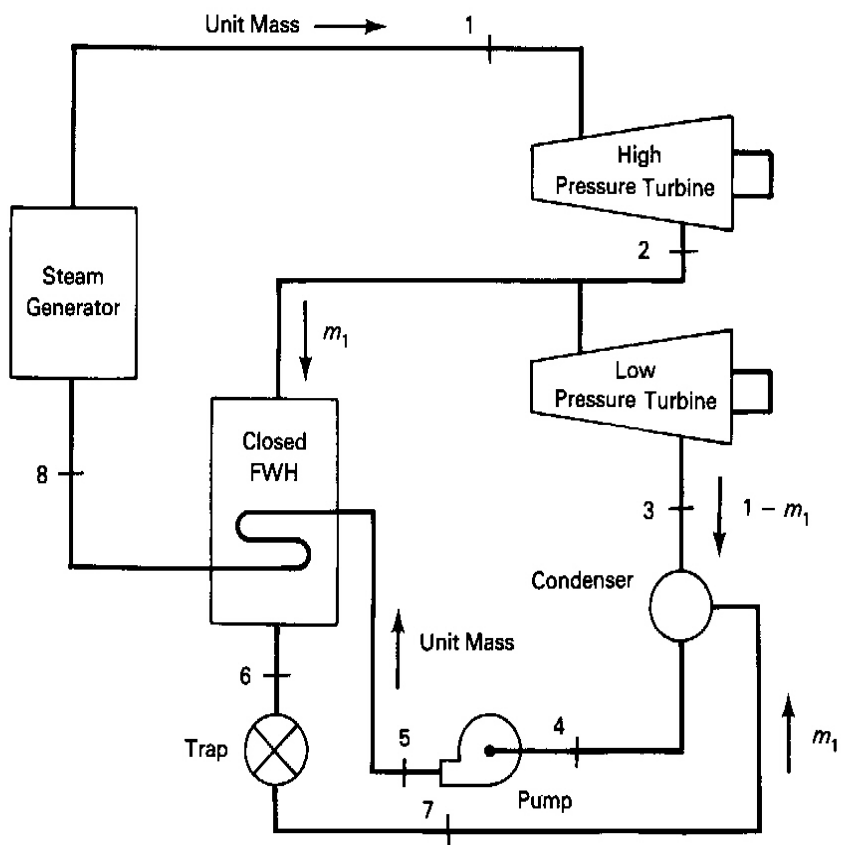

FIGURE 2.9 Regenerative Rankine cycle with closed feedwater heater and throttled condensate.

EXAMPLE 2.7

Rework Example 2.1 (2000 psia/1000°F/1 psia) with reheat and a closed feedwater heater with extraction from the cold reheat line and FWH condensate throttled to the condenser. Both reheat and extraction are at 200 psia. Assume that the feedwater leaving the FWH is at the temperature of the condensing extraction stream. Draw appropriate T-s and flow diagrams.

Solution

Referring to the notation of Figure 2.10, verify that the significant the thermodynamic state properties are:

State	Temperature (°F)	Pressure (psia)	Entropy (Btu/lb _m -°R)	Enthalpy (Btu/lb _m)
1	1000.0	2000	1.5603	1474.1
2	400.0	200	1.5603	1210.0
3	1000.0	200	1.84	1527.0
4	101.74	1	1.84	1028.0
5	101.74	1	0.1326	69.73
6	101.74	2000	0.1326	69.73
7	381.8	200	0.5438	355.5
8	101.74	1	—	355.5
9	381.8	2000	—	355.5

Applying the steady-flow First Law of Thermodynamics to the FWH, we obtain:

$$0 = h_9 + m_1 h_7 - m_1 h_2 - h_6 + 0$$

which, solved for m_1 , yields:

$$m_1 = (h_9 - h_6) / (h_2 - h_7) = (355.5 - 69.73) / (1210 - 355.5) = 0.3344$$

The total net work per unit of mass flow at the throttle of the HP turbine is the sum of the specific work of each of the turbines adjusted for the HP turbine throttle mass flow:

$$\begin{aligned} w_n &= h_1 - h_2 + (1 - m_1)(h_3 - h_4) \\ &= 1474.1 - 1210 + (1 - 0.3344)(1527 - 1028) = 596.2 \text{ Btu/lb}_m \end{aligned}$$

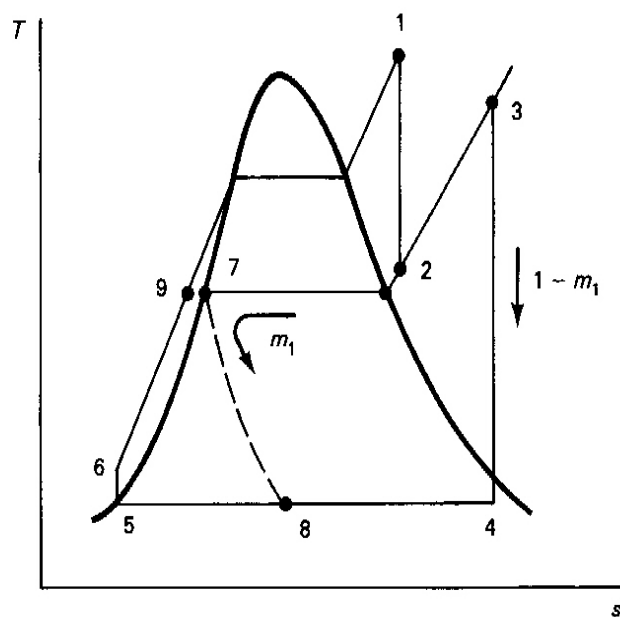
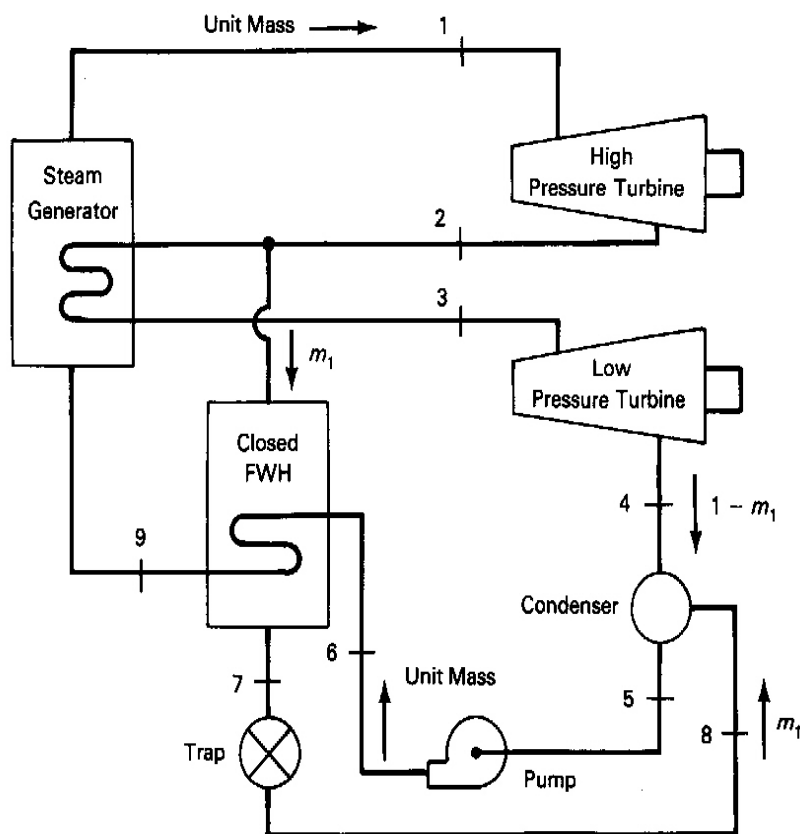

FIGURE 2.10 Rankine cycle with reheat and one closed feedwater heater.

As in the earlier examples in this series, pump work has been neglected.

The heat addition per unit HP-turbine-throttle mass is the sum of the heat addition in the main pass and reheat pass through the steam generator, the latter as adjusted for the reduced mass flow. Thus the steady-flow First Law of Thermodynamics yields

$$\begin{aligned} q_a &= h_1 - h_g + (1 - m_1)(h_3 - h_2) \\ &= 1474.1 - 355.5 + (1 - 0.3344)(1527 - 1210) = 1329.6 \text{ Btu/lb}_m \end{aligned}$$

The thermal efficiency of the cycle is $w_n / q_a = 596.2 / 1329.6 = 0.448$, or 44.8%.

The Mollier chart shows that the discharge of the first turbine (state 2) has 20 degrees of superheat and the second turbine (state 4) 7.4% moisture, or a quality of 0.926.

In the above calculation it was assumed that the feedwater temperature leaving the FWH had risen to the temperature of the condensing extraction steam. Since the FWH is a heat exchanger of finite area, the feedwater temperature T_g usually differs from the condensing temperature of the extraction steam T_7 . If the surface area of the FWH is small, the feedwater will emerge at a temperature well below the extraction-steam condensing temperature. If the area were increased, the feedwater temperature would approach the condensing temperature. This aspect of FWH design is reflected in the parameter known as the *terminal temperature difference*, TTD, defined as

$$\text{TTD} = T_{sat} - T_{fw} \quad [\text{R} \mid \text{K}]$$

where T_{fw} is the temperature of the feedwater leaving the tubes and T_{sat} is the condensing temperature of the extraction steam in the closed FWH. In Figure 2.10, for instance, $T_{fw} = T_g$ and $T_{sat} = T_7$. Thus, if the TTD and the extraction pressure are known, the true FWH exit temperature may be determined. An application of the TTD will be considered in a later example.

Table 2.1 summarizes, for comparison, the results of the calculations for the several plant configurations that we have considered. The reader is cautioned that since these calculations have not accounted for turbine inefficiency, the thermal efficiencies are unusually high. While the efficiency differences with respect to the simple cycle may seem insignificant, they are of great economic importance. It must be realized that hundreds of millions of dollars may be spent on fuel each year in a power plant and that capital costs are equally impressive. As a result, the choice of cycle and design characteristics are of great significance. Some further improvement in net work and efficiency could be shown by selecting extraction and reheat pressure levels to maximize these parameters.

Table 2.1 Comparison of Rankine Cycle Modifications

	Net Work (Btu/lb _m)	Efficiency %	Heat Rate (Btu/kW-hr)	Turbine Exit Quality
Simple cycle	603.1	42.9	7956	0.774
Reheat cycle	763.1	44.3	7704	0.926
One open FWH	518.1	46.3	7371	0.774
One closed FWH and reheat	596.2	44.8	7618	0.926

Multistage Extraction

It has been shown that increases in cycle efficiency may be accomplished in a steam power plant through regeneration via the feedwater heater. Large steam power plants typically employ large numbers of feedwater heaters for this purpose. *Multistage extraction* refers to the use of multiple extractions to supply steam to these feedwater heaters. Earlier discussions of examples involved extractions taken only from the flows between turbines. However, the number of extractions is not limited by the number of turbines. In fact, large turbines are designed with several extraction points through which steam may be withdrawn for feedwater heating and other purposes.

Assigning Extraction-Pressure Levels. Given n feedwater heaters, it is necessary to assign values to the n associated extraction pressures. For preliminary design purposes, the extraction-pressure levels assigned may be those that give equal feedwater temperature rises through each heater and through the steam generator to the boiling point. Thus, for n heaters the appropriate temperature rise is given by

$$\Delta T_{opt} = (T_{sl} - T_{cond}) / (n + 1) \quad [\text{R} \mid \text{K}] \quad (2.14)$$

where T_{sl} is the temperature the saturated liquid at the throttle pressure and T_{cond} is the temperature the feedwater leaving the condenser. The corresponding steam condensing temperature in the i th heater is then

$$\begin{aligned} T_i &= T_{cond} + (i) \Delta T_{opt} \\ &= T_{cond} + i (T_{sl} - T_{cond}) / (n + 1) \quad [\text{R} \mid \text{K}] \end{aligned} \quad (2.15)$$

where $i = 1, 2, \dots, n$. Steam tables may then be used to evaluate the corresponding extraction-pressure levels. It is, of course, possible and sometimes necessary to assign extraction-pressure levels in other ways.

EXAMPLE 2.8

Evaluate the recommended extraction-pressure levels for single heater for the 1000° F/2000 psia throttle and one psia condenser that have been used throughout this chapter.

Solution

The feedwater temperature rise to establish an appropriate extraction-pressure level for a single heater for a plant such as that shown in Figures 2.7 through 2.9 is $(T_{sl} - T_4)/2 = (635.8 - 101.74)/2 = 267.05^\circ\text{F}$ where T_{sl} was evaluated at $p_l = 2000$ psia. This would make $T_6 = 101.74 + 267.05 = 368.79^\circ\text{F}$ and the corresponding extraction pressure level $p_6 = p_2 = 171$ psia, using the saturated-steam tables.

At this point we have the tools necessary to evaluate the performance and penalties associated with a given configuration. The following example examines the gains that follow from the use a single feedwater heater and the sensitivity of the thermal efficiency to the assigned feedwater temperature rise.

EXAMPLE 2.9

Consider a single open feedwater heater operating in a Rankine cycle with a 2000 psia *saturated-vapor* throttle and a 1 psia condenser. Evaluate the thermal efficiency as a function of feedwater temperature rise. Compare the temperature rise that maximizes the thermal efficiency with the results of Equation (2.14).

Solution

Utilizing the notation of Figure 2.7 and taking the throttle state as a saturated vapor, we get the results that are summarized in spreadsheet format in Table 2.2. (This table is a direct reproduction of a Quattro Pro spreadsheet used in the analysis. Care should be taken if this spreadsheet is used for "what if" studies, because it is dependent on manual entry of thermodynamic properties. To explore other cases, appropriate properties must be obtained from steam tables or charts and inserted in the spreadsheet. Despite this drawback, the spreadsheet provides a convenient means of organizing, performing, and displaying calculations.) Details of the methodology are given in the right-most column. It is seen that the net work drops, as expected, as more extraction steam is used to heat the feedwater. Figure 2.11 shows the percentage increase in thermal efficiency as a function of the feedwater temperature rise for this case. Over a 9% increase in thermal efficiency is achieved with feedwater temperature rises between 200° F and 300° F. Thus the prediction of $T_{\text{opt}} = 267^\circ\text{F}$ using Equation (2.14) in Example 2.8 is clearly in this range.

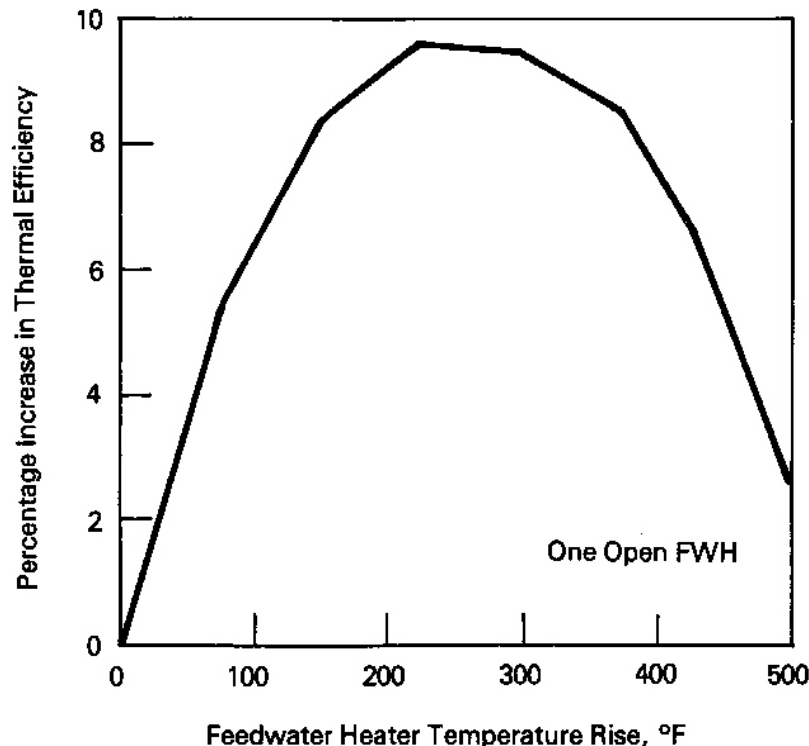

FIGURE 2.11 Feedwater heater optimization.

Example 2.9 shows that improved thermal efficiency is achieved over a broad range of feedwater temperature rise and therefore extraction pressure. This gives the designer freedom to assign extraction-pressure levels so as to make use of existing designs for feedwater heaters and turbines without severely compromising the efficiency of the plant design.

Calculation Methodology. Once the extraction- and reheat-pressure levels are established for a cycle with multistage extraction, and once throttle and condenser conditions, turbomachine efficiencies, and FWH terminal temperature differences are known, significant state properties should be determined. Symbols for extraction mass-fraction variables should be assigned for each heater and related to other unknown flows using mass conservation assuming unit mass flow at the high-pressure-turbine throttle. The steady-flow First Law of Thermodynamics should then be applied to each of the FWHs, starting with the highest extraction pressure and progressing to the lowest-pressure FWH. Analyzing the heaters in this order allows each equation to be solved immediately for a mass fraction rather than solving all of the equations simultaneously. Important performance parameters such as thermal efficiency, net work, and work ratio may then be evaluated taking care to account properly for component mass flows. The following example illustrates this methodology.

TABLE 2.2 Spreadsheet Solution to Example 2.9

Calculations for Example 2-9										
T1, F	635.8	635.8	635.8	635.8	635.8	635.8	635.8	635.8	635.8	635.8 Table lookup
p1, psia	2000	2000	2000	2000	2000	2000	2000	2000	2000	2000 assigned
s1, Btu/lb-R	1.29	1.29	1.29	1.29	1.29	1.29	1.29	1.29	1.29	1.29 Table lookup
h1, Btu/lb	1139	1139	1139	1139	1139	1139	1139	1139	1139	1139 Table lookup
p3, psia	1	1	1	1	1	1	1	1	1	1 assigned
s3, Btu/lb-R	1.29	1.29	1.29	1.29	1.29	1.29	1.29	1.29	1.29	1.29 s3=s1
x3	0.627147	0.627147	0.627147	0.627147	0.627147	0.627147	0.627147	0.627147	0.627147	$x3=(s3-s4)/(sv-s4)$ $=(s3-0.1326)/(1.8455)$
h3, Btu/lb	719.5171	719.5171	719.5171	719.5171	719.5171	719.5171	719.5171	719.5171	719.5171	$h3=h4+(x3)(hv-h4)$ $=69.7+1036.1(x3)$
T3, F	101.74	101.74	101.74	101.74	101.74	101.74	101.74	101.74	101.74	101.74 Table lookup
p4, psia	1	1	1	1	1	1	1	1	1	1 p4=p3
T4, F	101.74	101.74	101.74	101.74	101.74	101.74	101.74	101.74	101.74	101.74 Table lookup
h4, Btu/lb	69.73	69.73	69.73	69.73	69.73	69.73	69.73	69.73	69.73	69.73 Table lookup
number of FWHs	1	1	1	1	1	1	1	1	1	1 i=1
T6-T4, F	500	425	375	300	225	150	75	0	0	0 assigned
T6, F	601.74	526.74	476.74	401.74	326.74	251.74	176.74	101.74	101.74	$T6=T4+i(T6-T4)$
s6, Btu/lb-R	0.816	0.7243	0.661	0.569	0.473	0.3706	0.2585	0.133	0.133	0.133 Table lookup
h6, Btu/lb	620	520	460.6	377.2	297.7	220.62	145	69.5	69.5	69.5 Table lookup
hv at p6, Btu/lb	1166.3	1197.8	1204.35	1201.2	1186.9	1164.7	1137	1105.8	1105.8	1105.8 Table lookup
sv-s6 at p6	0.515	0.686	0.799	0.956	1.13	1.3266	1.557	1.845	1.845	1.845 Table lookup
h2, Btu/lb	1122.808	1078.938	1046.105	998.6477	940.5995	874.9146	802.192	719.364	719.364	$h2=h6+(s1-s6)(hv-h6)/(sv-s6)$
m1	0.522535	0.446162	0.400328	0.330998	0.261773	0.187398	0.102763	-0.00035	-0.00035	$m1=(h6-h4)/(h2-h4)$
net work, Btu/lb	208.7493	259.123	288.7406	327.0912	361.6095	390.3617	410.987	419.4828	419.4828	$wn=h1-h2+(1-m1)(h2-h3)$
thermal eff.	0.402	0.419	0.426	0.429	0.430	0.425	0.413	0.392	0.392	$eff=wn/(h1-h6)$
% change	2.547	6.729	8.515	9.470	9.586	8.371	5.416	0.000	0.000	

EXAMPLE 2.10

Consider a power plant with 1000°F/2000-psia throttle, reheat at 200 psia back to 1000°F, and 1-psia condenser pressure. The plant has two closed feedwater heaters, both with terminal temperature differences of 8°F. The high-pressure (HP) heater condensate is throttled into the low-pressure (LP) heater, which in turn drains into the condenser. Turbomachine efficiencies are 0.88, 0.9, and 0.8 for the HP turbine, the LP turbine, and the boiler feed pump, respectively. Draw relevant T-s and flow diagrams and evaluate FWH mass fractions, thermal efficiency, net work, and work ratio.

Solution

The notation used to study this plant is shown in Figure 2.12. The pertinent thermodynamic properties and part of the analysis are presented in the spreadsheet given in Table 2.3. The earlier-stated caution (Example 2.9) about using spreadsheets that incorporate external data applies here as well, because changing parameters may require changes in steam-table lookup values.

To start the analysis we first determine the extraction-pressure levels. The ideal FWH temperature rise is given by

$$(T_{st} - T_7)/3 = (635.8 - 101.74)/3 = 178.02^\circ\text{F}$$

where the saturation temperature is evaluated at the HP-turbine throttle pressure of 2000 psia. The corresponding extraction condensing temperatures and extraction-pressure levels are

$$101.74 + 178.02 = 280^\circ\text{F} \rightarrow p_9 = p_5 = 49 \text{ psia}$$

and

$$101.74 + (2)(178.02) = 457.8^\circ\text{F} \rightarrow p_{12} = p_2 = 456 \text{ psia}$$

where the extraction pressures have been evaluated using the saturated-steam tables.

After the entropy and enthalpy at state 1 are evaluated, the enthalpy h_{3s} at the HP-turbine isentropic discharge state 3s is determined from s_1 and p_3 . The HP-turbine efficiency then yields h_3 and the steam tables give s_3 . The entropy and enthalpy at the HP-turbine extraction state 2 may be approximated by drawing a straight line on the steam Mollier diagram connecting states 1 and 3 and finding the intersection with the HP-extraction pressure P_2 . This technique may be used for any number of extraction points in a turbine.

Once the hot reheat properties at state 4 are determined from the steam tables, the LP-turbine exit and extraction states at 6 and 5 may be obtained by the same method used for the HP turbine.

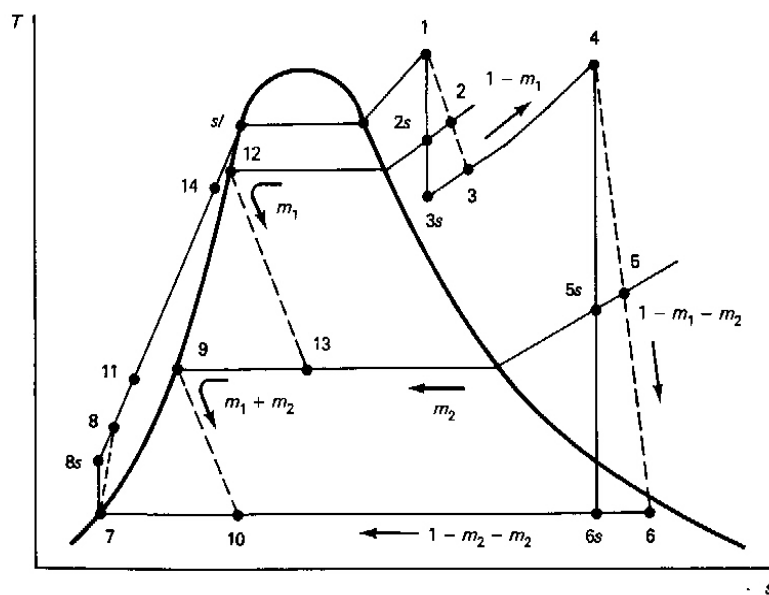
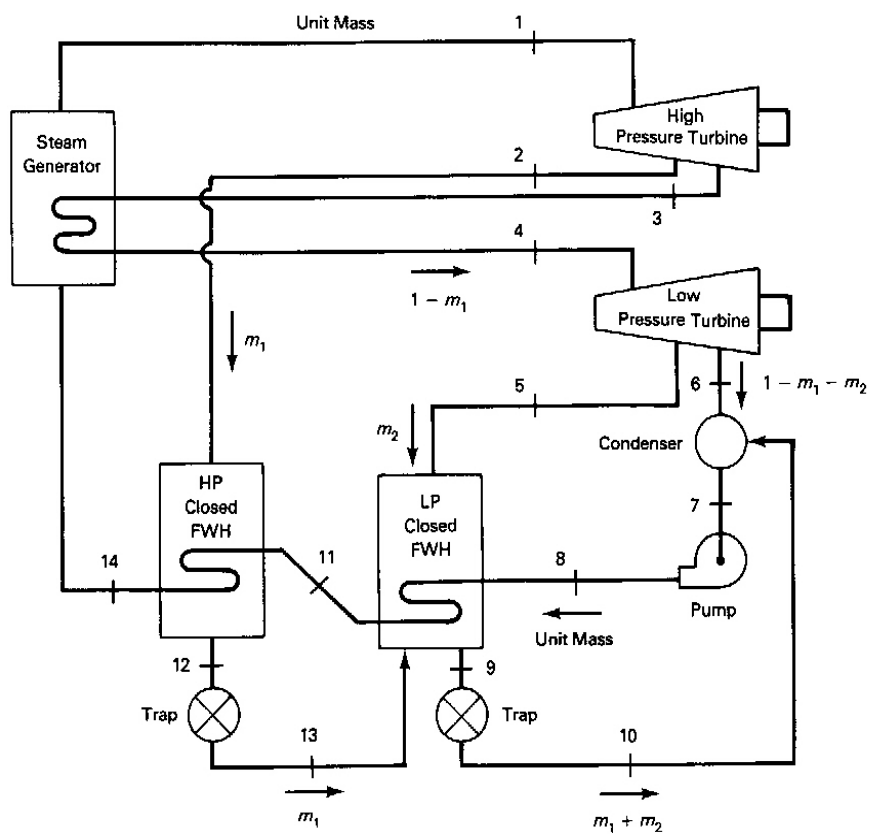

FIGURE 2.12 Rankine cycle with reheat and two closed feedwater heaters.

TABLE 2.3 Spreadsheet Solution to Example 2.10

Rankine Cycle Analysis - Reheat and 2 feedwater heaters					
Efficiencies:		Pump:	0.8	TTD (F) =	8.0
		Turbines			
		HP:	0.88		
		LP:	0.9		
State	Temp. F	Pressure psia	Entropy Btu/lb-R	Enthalpy Btu/lb	Comment
1	1000	2000	1.5603	1474.1	given
2s	575	456	1.5603	1289.0	
2		456	1.5860	1316.0	
3s		200	1.5603	1210.0	
3		200	1.5960	1241.7	
4	1000	200	1.8400	1527.0	
5s		49	1.8400	1333.0	
5		49	1.8710	1368.0	
6s		1	1.8400	1027.0	
6		1	1.9300	1077.0	M=2.7
7	101.74	1	0.1326	69.7	v=.016136 cu.ft./lbm
8s		2000	0.1326	75.7	
8		2000		77.2	
9	281	49	0.4090	248.7	sat. liq.
10		1		248.7	
11	273	2000		242.0	
12	457.5	456	0.6380	439.0	sat. liq.
13		49		439.0	
14	449.5	2000		429.7	
m1 = (h14-h11)/(h2-h12) =			0.214025	1-m1 =	0.785975
m2=[m1(h9-h13)+h11-h8]/(h5-h9)=			0.110853	1-m1-m2 =	0.675121
Wt = h1-h2 + (1-m1)(h2-h3) + (1-m1)(h4-h5) + (1-m1-m2)(h5-h6) =					
			537.9 Btu/lb		
Wp = h7-h8 =			-7.5 Btu/lb		
Wn = Wt + Wp =			530.5 Btu/lb		
Qa = h1-h14 + (1-m1)(h4-h3) =			1268.6 Btu/lb		
Thermal efficiency =			0.418		
Heat Rate =			8162.3 Btu/kW-hr		
Work ratio = Wt/Wp =			72.1		

The determination of the FWH condensate temperatures and pressures at states 9 and 12 have already been discussed. The temperatures of the heated feedwater leaving the FWHs may be determined from the terminal temperature differences:

$$T_{11} = T_9 - \text{TTD} = 281 - 8 = 273^\circ\text{F}$$

$$T_{14} = T_{12} - \text{TTD} = 457.5 - 8 = 449.5^\circ\text{F}$$

Recalling that the enthalpy of a subcooled liquid is almost independent of pressure, we note that the enthalpies h_{11} and h_{14} may be found in the saturated-liquid tables at T_{11} and T_{14} , respectively.

The pump discharge state 8 is a subcooled-liquid state, which may be approximated in the same way as in Examples 2.3 and 2.4. Thus

$$\begin{aligned} h_{8s} &= h_7 + (p_8 - p_7)v_7 \\ &= 69.7 + (2000 - 1)(144)(0.016136)/778 = 75.7 \text{ Btu/lb}_m \end{aligned}$$

and

$$h_8 = h_7 + (h_{8s} - h_7)/\eta_p = 69.7 + (75.7 - 69.7)/0.8 = 77.2 \text{ Btu/lb}_m$$

The pump work is then

$$w_p = h_7 - h_8 = 69.7 - 77.2 = -7.5 \text{ Btu/lb}_m$$

The extraction mass-flow fractions designated m_1 and m_2 relate other flows to the unit mass flow at the high-pressure-turbine throttle. For example, the condensate flow rate from the LP heater at state 10 is given by $m_1 + m_2$.

The steady-flow First Law of Thermodynamics may now be applied to the heaters. For the HP FWH:

$$0 = m_1 h_{12} + (1)h_{14} - m_1 h_2 - (1)h_{11}$$

may be rewritten as

$$m_1 = (h_{14} - h_{11}) / (h_2 - h_{12}) \quad [\text{dl}]$$

This and the T-s diagram show that the HP extraction-flow enthalpy drop from state 2 to state 12 provides the heat to raise the enthalpy in the feedwater from state 11 to state 14. Also, for the LP FWH:

$$0 = (1)h_{11} + (m_2 + m_1)h_9 - (1)h_8 - m_2 h_5 - m_1 h_{13}$$

becomes

$$m_2 = [m_1(h_9 - h_{13}) + h_{11} - h_8] / (h_5 - h_9) \quad [\text{dl}]$$

This and the T-s diagram show that the discharge from the HP FWH at state 13 aids the mass flow m_2 in heating the LP FWH flow from state 8 to state 11. The values of m_1 and m_2 are evaluated at the bottom of spreadsheet in Table 2.3.

With all states and flows known, we may now determine some plant performance parameters. The turbine work referenced to the throttle mass-flow rate is easily obtained by summing the flow contributions through each section of the turbines:

$$w_t = h_1 - h_2 + (1 - m_1)(h_2 - h_3) + (1 - m_1)(h_4 - h_5) + (1 - m_1 - m_2)(h_5 - h_6) \quad [\text{Btu/lb}_m \mid \text{kJ/kg}]$$

The net work is then $w_t + w_p$, and the heat added in the steam generator is the sum of heat additions in the feedwater pass and the reheat pass:

$$q_a = h_1 - h_{14} + (1 - m_1)(h_4 - h_3) \quad [\text{Btu/lb}_m \mid \text{kJ/kg}]$$

These parameters and the work ratio are evaluated in Table 2.3.

Example 2.10 shows that a good thermal efficiency and net work output are possible with the use of two feedwater heaters despite taking into account realistic turbomachine inefficiencies. The high work ratio clearly demonstrates the low-compression work requirements of Rankine cycles.

2.7 A Study of a Modern Steam Power Plant

Modern steam power plants incorporate both reheat and feedwater heating. A flowsheet for the Public Service Company of Oklahoma (PSO) Riverside Station Unit #1, south of Tulsa, is shown in Figure 2.13. This natural-gas-burning plant was sized for two nominal 500-megawatt units. Several other plants in the PSO system have similar unit flowsheets, including a coal-burning plant. Note the flowsheet coding W, H, F, and A for flow rate in lb_m/hr , enthalpy in Btu/lb_m , temperature in $^\circ\text{F}$, and pressure in psia, respectively.

The steam generator, not shown on the flowsheet, interacts through the feedwater and steam lines on the right-hand side of the diagram. The high pressure turbine throttle is at 1000°F and 3349 psia and has a mass-flow rate of 2,922,139 lb_m/hr . This type of unit is called *supercritical*, because the pressure in the main steam line to the HP-turbine throttle exceeds the 3208.2-psia critical pressure of steam. Note that a large fraction of the HP-turbine mass-flow rate enters the cold reheat line at 630 psia and is reheated to the intermediate-pressure (IP) turbine throttle conditions of 1000°F and 567 psia.

Most of the steam flow through the IP turbine passes through the crossover at 186 psia to the double-flow low-pressure (DFLP) turbine. The term *double-flow* refers to the fact that the incoming flow enters at the middle, splits, and flows axially in opposite

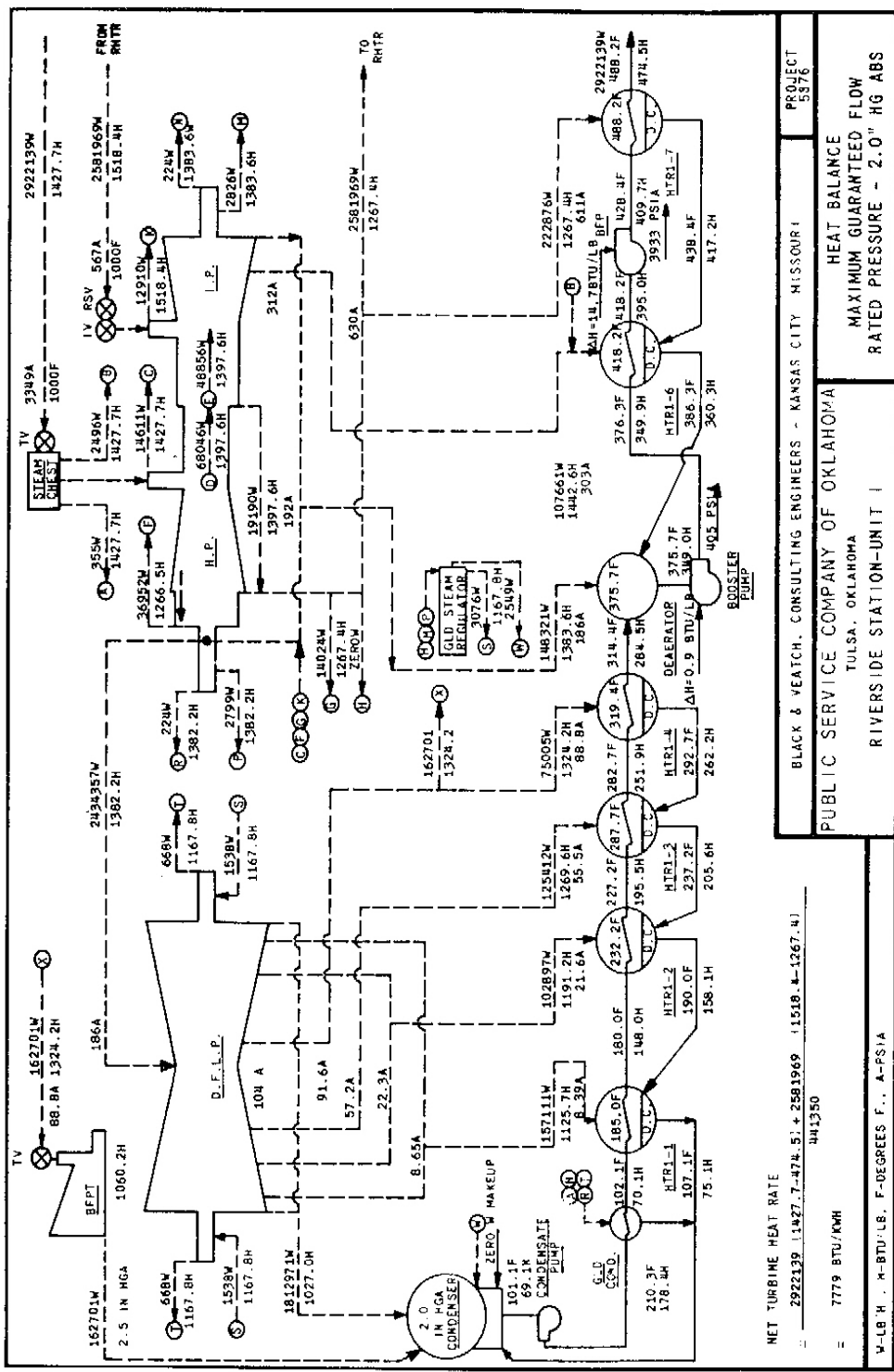

FIGURE 2.13 Thermodynamic properties and flow rates in a modern natural-gas-burning steam power plant—PSO Riverside Station Unit #1. (Courtesy of Public Service Company of Oklahoma.)

directions through the turbine. This causes the large axial force components on the blades and shaft to oppose each other so that the resultant axial thrust is small and does not necessitate heavy thrust bearings. The combined HP and IP turbines are similarly configured.

The plant is equipped with six closed FWHs and one open FWH (the deaerator). Note that the condensate of each of the closed feedwater heaters is throttled to the next lowest pressure FWH or, in the case of the lowest-pressure heater, to the condenser. The extraction steam for the four lowest-pressure FWHs flows from the DFLP turbine. Extraction steam for the highest pressure FWH is provided by the HP turbine, and the IP turbine supplies heater HTR1-6 and the open feedwater heater identified as the deaerator. The *deaerator* is specially designed to remove non-condensable gases from the system, in addition to performing its feedwater heating duties.

The feedwater starts at the "hot well" of the condenser on the left of the diagram, enters the condensate pump at 101.1°F and 2"Hg abs., and starts its passage through the FWHs. Note that the feedwater increases in temperature from 102.1° to 180°, 227.2°, 282.7°, and 314.4° in passing through the 4 lowest pressure FWHs. The feedwater from the deaerator is pumped to 405 psia by the booster pump and subsequently to 3933 psia by the boiler feed pump (BFP). The BFP exit pressure exceeds the HP-turbine throttle pressure of 3349 psia in order to overcome flow losses in the high pressure heater, the boiler feed line, the steam generator main steam pass, and the main steam line, all of which operate at supercritical pressure.

The boiler feed pump turbine (BFPT) shown in the upper left of the diagram supplies the shaft power to drive the BFP at the lower right. The BFPT receives steam from an extraction line of the DFLP turbine and exhausts directly to the condenser.

The reader should study Figure 2.13 thoroughly in the light of the preceding discussions of reheat and feedwater heating. It is particularly useful to consider the flow rates with respect to mass and energy conservation. Mastery of this flow sheet will make it possible to quickly understand flowsheets of other major power plants.

Example 2.11

Verify that the steam generator feedwater flow rate satisfies the conservation of mass into all the feedwater heaters shown for the Riverside Unit #1 in Figure 2.13. You may neglect all flows of less than 2000 lb_m/hr.

Solution

The shell side of the low pressure heater, labeled HTR1-1, receives condensate from heaters 2, 3 and 4 as well as steam entering from the LP turbine. The total condensate from the low-pressure heaters into the condenser are:

Source	Flow rate, lb _m /hr
Condensate from HTR1-4	75,005
Extraction steam into HTR1-3	125,412
Extraction steam into HTR1-2	102,897

Total condensate into HTR1-1	303,314
Extraction steam into HTR1-1	157,111

Total condensate leaving HTR1-1	460,425

The feedwater flow rate through the four low-pressure heaters (the condenser condensate pump flow rate) is the sum of the flows into the condenser:

$$460,425 + 162,701 + 1,812,971 = 2,436,097 \text{ lb}_m/\text{hr}.$$

An easier approach to evaluating this flow rate is by imagining a control volume around the entire left side of the diagram that cuts it in two parts between the deaerator and HTR1-4 and through the crossover steam line. Because these are the only points where the control volume is penetrated by large mass flows, the two flows must be equal. Consequently the crossover mass-flow rate of 2,434,357 lb_m/hr agrees very well with our above calculation of the feedwater flow rate into the deaerator.

Now, observing that the boiler feedwater all flows from the deaerator through the booster pump, we sum all of the flows into the deaerator:

Feedwater into deaerator	2,434,357
Steam to deaerator	148,321
Steam to HTR1-6	107,661
Steam to HTR1-7	222,876

Total feedwater into HTR1-7	2,913,215 lb _m /hr

This compares well with the tabulated value of 2,922,139 lb_m /hr to the steam generator. Accounting for the small flows should improve the agreement.

2.8 Deviations from the Ideal - Pressure Losses

It is evident from study of Figure 2.13 that there are significant pressure drops in the flows through the steam generator between the HP FWH and the HP-turbine throttle and in the reheat line between the HP and IP turbines. While we have neglected such losses in our calculations, final design analysis requires their consideration. A first attempt at this may be made by applying a fractional pressure drop based on experience. Two per cent pressure drops through the main steam and feedwater lines and a 3.7% loss through the steam generator would, for instance, account for the indicated 14.8% loss from the boiler feed pump to the HP turbine.

In the final analysis, of course, when realistic values are available for flow rates and properties, known fluid mechanic relations for pressure drop may be employed to account for these losses.

Bibliography and References

1. Anon., *Steam, Its Generation and Use*. New York: Babcock and Wilcox, 1978.
2. Singer, J. G., (Ed.), *Combustion/Fossil Power Systems*. Windsor, Conn.: Combustion Engineering, 1981.
3. Wood, Bernard, *Applications of Thermodynamics*, 2nd ed. Reading, Mass.: Addison-Wesley, 1981.
4. Li, Kam W., and Priddy, A. Paul, *Powerplant System Design*. New York: Wiley, 1985.
5. El-Wakil, M. M., *Power Plant Technology*. New York: McGraw-Hill, 1984.
6. Skrotzi, B. G. A. and Vopat, W. A., *Power Station Engineering and Economy*. New York: McGraw-Hill, 1960.

EXERCISES

2.1 An ideal Rankine-cycle steam power plant has 800-psia saturated steam at the turbine throttle and 5-psia condenser pressure. What are the turbine work, pump work, net work, steam generator heat addition, thermal efficiency, maximum cycle temperature, and turbine exit quality? What is the Camot efficiency corresponding to the temperature extremes for this cycle?

2.2 A Rankine-cycle steam power plant has an 800-psia/900°F throttle and 5-psia condenser pressure. What are the net work, turbine work, pump work, steam generator

heat addition, thermal efficiency, and turbine exit quality? What is the Carnot efficiency corresponding to the temperature extremes for this cycle?

2.3 Solve Exercise 2.2 for the cases of (a) an 85% efficient turbine, (b) an 85% efficient pump, and (c) both together. Tabulate and discuss your results together with those of Exercise 2.2.

2.4 Solve Exercise 2.2 for the case of (a) 1000°F throttle, (b) 2000-psia throttle, (c) 2-psia condenser, and (d) all three changes simultaneously. Make a table comparing net work, quality, and thermal efficiency, including the results of Exercise 2.2. What conclusions can you draw from these calculations?

2.5 Sketch coordinated, labeled flow and T-s diagrams for the ideal Rankine cycle. Tabulate the temperatures, entropies, pressures, enthalpies, and quality or degree of superheat for each significant state shown on the diagram for a throttle at 1000 psia and 1000°F and a condenser at 5 psia. Determine the net work, heat added, thermal efficiency, heat rate, and heat rejected in the condenser. If the power plant output is 100 megawatts and the condenser cooling-water temperature rise is 15 Rankine degrees, what is the steam flow rate and cooling-water flow rate? Neglect pump work.

2.6 Consider a simple Rankine cycle with a 2000-psia/1100°F throttle and 1-psia condenser. Compare the thermal efficiencies and net work for cycles with a perfect turbine and one having 86% turbine isentropic efficiency. Assume isentropic pumping.

2.7 A boiling-water reactor operates with saturated vapor at 7500 kPa at the throttle of the high-pressure turbine. What is the lowest turbine exit pressure that ensures that the turbine exit moisture does not exceed 12% if the turbine is isentropic? What would the lowest pressure be if the turbine isentropic efficiency were 85%?

2.8 Consider a steam plant with a single reheat and a single open feedwater heater that takes extraction from the cold reheat line. Sketch carefully coordinated and labeled T-s and flow diagrams. If the throttle is at 1000°F and 3000psia, the condenser is at 1 psia, and reheat is to 1000°F at 400 psia, what is the extraction mass fraction, the heat rate, and the thermal efficiency? The turbine efficiency is 89%. Neglect pump work.

2.9 A Rankine-cycle power plant condenses steam at 2 psia and has 1000°F and 500 psia at the turbine throttle. Assume an isentropic turbine.

(a) Tabulate the temperature, pressure, entropy, and enthalpy of all states. Determine the quality and moisture fraction for all mixed states.

(b) Calculate the heat transferred in the condenser and the steam generator and the turbine work, all per unit mass. What is the thermal efficiency?

(c) Calculate the pump work. What is the ratio of turbine to pump work?

(d) What is the turbine work and thermal efficiency if the turbine efficiency is 85%? Include pump work.

2.10 For throttle conditions of 1000°F and 1000 psia and a condenser pressure of 2 psia, compare the net work, thermal efficiency, and turbine discharge quality or degree of superheat for a simple cycle and two reheat cycles with reheat to 1000°F at 50 and 200 psia. Tabulate your results. Sketch a single large, labeled T-s diagram comparing the cycles. Turbine isentropic efficiencies are 85%.

2.11 Consider a regenerative Rankine cycle with a 1000°F and 500-psia throttle, 2-psia condenser, and an open feedwater heater operating between two turbines at 50 psia. Turbine efficiencies are 85%. Neglect pump work.

(a) Draw labeled, coordinated T-s and flow diagrams.

(b) Determine the fraction of the throttle mass flow that passes through the extraction line.

(c) Calculate the turbine work per unit mass at the throttle.

(d) Calculate the cycle efficiency, and compare it to the simple-cycle efficiency.

2.12 Consider a 1120°F, 2000-psia, 10-psia steam cycle with reheat at 200 psia to 1000°F and a closed feedwater heater taking extraction from a line between two turbines at 100psia. The FWH condensate is throttled to the condenser, and the feedwater in the FWH is raised to the condensing temperature of the extraction steam.

(a) Draw labeled T-s and flow diagrams for this plant.

(b) Tabulate the enthalpies for each significant state point.

(c) What is the extraction fraction to the FWH?

(d) What are the net work and work ratio?

(e) What are the thermal efficiency and the heat rate?

2.13 A turbine operates with a 860°F, 900-psia throttle. Calorimetric measurements indicate that the discharge enthalpy is 1250 Btu/lb_m at 100 psia. What is the isentropic efficiency?

2.14 An ideal Rankine cycle has 1000-psia saturated steam at the turbine throttle. The condenser pressure is 10psia. What are the turbine work, steam generator heat addition, maximum cycle temperature, turbine exit quality, and Carnot efficiency corresponding to the temperature extremes of the cycle? Neglect pump work.

2.15 Assume that the extraction mass-flow rate to FWH #7 in Figure 2.13 is not known. Calculate the FWH extraction mass fraction (relative to the HP-turbine throttle flow) and the extraction mass-flow rate. Compare the extraction-steam energy loss rate with the feedwater energy gain rate.

2.16 Compare the inflow and outflow of steam of the DFLP turbine in Figure 2.13, and calculate the percentage difference. Calculate the power output of the DFLP turbine in Btu/hr and in kW.

2.17 Calculate the power delivered by the PSO Riverside Unit #1 boiler feed pump turbine, BFPT. Based on the feedwater enthalpy rise across the BFP, determine its power requirements, in kilowatts. What fraction of the plant gross output is used by the BFPT?

2.18 Without performing a detailed analysis of the FWHs, determine the PSO Riverside Unit #1 feedwater flow rate from heater number 4 to the deaerator. Explain your methodology.

2.19 Total and compare the inflows and outflows of mass and energy to the PSO Riverside Unit #1 deaerator.

2.20 Rework Example 2.4 neglecting pump work. Repeat your calculations for an 80% efficient pump. Compare and comment on the significance of accounting for pump work and turbomachine efficiency.

2.21 For a 1080°F, 2000-psia, 5-psia Rankine cycle with 85% turbine efficiency and 60% pump efficiency:

(a) Compare the actual net work and the isentropic turbine work and the isentropic net work.

(b) Calculate the actual heat transfer and work for each component, and evaluate the cyclic integrals of Q and W .

(c) Compare the real cycle efficiency with that for the ideal Rankine cycle.

2.22 For a 1080°F, 2000-psia, 5-psia Rankine cycle with 85% turbine efficiency and 60% pump efficiency, evaluate the effect of a single reheat to 1080°F at 500 psia on:

(a) Heat addition in the steam generator.

(b) Work of each turbine, total turbine work, and net work. Compare the net work with the cyclic integral of the external transfers of heat.

(c) Cycle efficiency and heat rate.

(d) Quality or degree of superheat at the exit of the turbines.

Draw labeled flow and T-s diagrams.

2.23 Consider a 1080°F, 2000-psia, 5-psia Rankine cycle with 85% turbine efficiency and 60% pump efficiency. Compare the simple cycle with the same cycle operating with a single reheat to 1080°F at 1000 psia with respect to:

(a) Heat addition in the steam generator.

(b) Work of each turbine, total turbine work and net work, condenser heat rejection, and cyclic integral of heat added.

- (c) Cycle efficiency.
 - (d) Quality or degree of superheat at the exit of the turbines.
- Draw labeled flow and T-s diagrams.

2.24 For a 1080°F, 2000-psia, 5-psia Rankine cycle with 85% turbine efficiencies and 60% pump efficiencies and using a single open feedwater heater operating at 500 psia:

- (a) Draw labeled and coordinated flow and T-s diagrams.
- (b) Evaluate the feedwater heater mass fraction.
- (c) Evaluate heat addition in the steam generator, work of each turbine, total turbine work, and net work, all per pound of steam at the HP-turbine throttle.
- (d) Evaluate condenser heat transfer per unit mass at the HP-turbine throttle.
- (e) Evaluate cycle efficiency and heat rate. Compare with simple-cycle efficiency.
- (f) Evaluate the cyclic integral of the differential heat addition, and compare it with the net work.

2.25 Consider a 1080°F, 2000-psia, 5-psia Rankine reheat-regenerative cycle with perfect turbomachinery and a closed feedwater heater taking extraction from the cold reheat line at 500 psia. FWH condensate is pumped into the feedwater line downstream of the feedwater heater. Assume that the enthalpy of the feedwater entering the steam generator is that of the saturated liquid leaving the FWH.

- (a) Draw coordinated and labeled flow and T-s diagrams.
- (b) Determine the extraction mass fraction, the net work, and the total heat addition.
- (c) Determine the thermal efficiency and heat rate.
- (d) Determine the superheat or quality at the turbine exhausts:

2.26 Taking the reheat-pressure level as a variable, plot net work, thermal efficiency, and turbine exhaust superheat and/or moisture against reheat pressure for the conditions of Example 2.5. Select a suitable design value based on your analysis.

2.27 Solve Example 2.6 for 1200°F throttle substituting a closed FWH for the open heater. Consider two cases in which the FWH condensate is (a) throttled to the condenser, and (b) pumped to throttle pressure.

2.28 Solve Example 2.6 using the method for assigning extraction-pressure levels given in the subsection of Section 2.6 on multistage extraction systems.

2.29 Solve Example 2.7 using the method for assigning extraction-pressure levels given in the section on multistage extraction systems, and determine by trial and error the reheat-pressure level that maximizes the thermal efficiency.

2.30 Solve Example 2.7 with the extraction condensate from the closed FWH pumped ahead to the feedwater-pressure level.

- 2.31 Solve Example 2.6 for 900°F throttle temperature with the open FWH replaced by a closed FWH where the feedwater is (a) throttled to the condenser, and (b) pumped into the feedwater line downstream of the FWH.
- 2.32 Compare the work and exhaust quality of 90% efficient turbines with 2500-psia throttle pressure and 1000°F and 1200°F throttle temperatures exiting to a 2-psia condenser.
- 2.33 Draw a large T-s diagram showing the states associated with the important flows of the PSO Riverside Unit #1 (Figure 2.13).
- 2.34 A Rankine-cycle steam power plant has 5-MPa saturated steam at the turbine throttle and 25-kPa condenser pressure. What are the net work, steam generator heat addition, thermal efficiency, heat rate, maximum cycle temperature, and turbine exit quality? What is the Carnot efficiency corresponding to the temperature extremes for this cycle?
- 2.35 A Rankine-cycle steam power plant has a 5-MPa/450°C throttle and 10-kPa condenser pressure. What are the net work, steam generator heat addition, thermal efficiency, heat rate, and turbine exit quality? What is the Carnot efficiency corresponding to the temperature extremes for this cycle?
- 2.36 Solve Exercise 2.35 for the cases of (a) an 85% efficient turbine, (b) an 85% efficient pump, and (c) both together. What conclusions may be inferred from your results?
- 2.37 Solve Exercise 2.35 for the case of (a) a 550°C throttle, (b) a 15-MPa throttle, (c) a 5-kPa condenser, and (d) all three changes simultaneously. What conclusions can you draw from these calculations?
- 2.38 Sketch coordinated, labeled flow and T-s diagrams for the following Rankine cycle. Tabulate the temperatures, entropies, pressures, enthalpies, and quality or degree of superheat for each significant state shown on the diagram for a throttle at 10 MPa and 550°C and condenser at 5 kPa. Determine the net work, heat added, thermal efficiency, and heat rejected in the condenser. If the power plant output is 100 megawatts and the condenser cooling water temperature rise is 15° Rankine, what is the steam flow rate and cooling-water flow rate? Neglect pump work.
- 2.39 Consider a Rankine cycle with a 20MPa/600°C throttle and 3-kPa condenser. Compare the thermal efficiencies and net work for cycles with a perfect turbine and one having 86% turbine isentropic efficiency.

2.40 Consider a steam plant, with a single reheat and a single open feedwater heater, that takes extraction from the cold reheat line. Sketch carefully coordinated and labeled T-s and flow diagrams. If the throttle is at 550°C and 15 MPa, the condenser is at 5 kPa, and reheat is to 3 MPa and 550°C , what are the extraction mass fraction, work ratio, and thermal efficiency? The pump and turbine efficiencies are 82% and 89%, respectively.

2.41 A Rankine-cycle power plant condenses steam at 10 kPa and has 550°C and 5 MPa at the turbine throttle. Assume an isentropic turbine.

- Tabulate the temperature, pressure, entropy, and enthalpy of all states. Determine the quality and moisture fraction for all mixed states.
- Calculate the heat transferred in the condenser and steam generator and the turbine work, all per unit mass. What is the thermal efficiency?
- Calculate the pump work. What is the ratio of turbine to pump work?
- What is the turbine work and thermal efficiency if the turbine efficiency is 85%? Include pump work.

2.42 For throttle conditions of 550°C and 5 MPa and a condenser pressure of 10 kPa, compare the net work, thermal efficiency, and turbine discharge quality or degree of superheat for a simple cycle and two reheat cycles. Consider reheat to 500°C at (a) 4 MPa and (b) 1 MPa. Tabulate and compare your results. Sketch a large, labeled T-s diagram for a reheat cycle. Turbine efficiencies are 85%.

2.43 Consider a regenerative Rankine cycle with a 600°C and 4-MPa throttle, a 5-kPa condenser, and an open feedwater heater at 500 kPa. Turbine efficiencies are 85%. Neglect pump work.

- Draw labeled, coordinated T-s and flow diagrams.
- Determine the fraction of the throttle mass flow that passes through the extraction line.
- Calculate the turbine work per unit mass at the throttle.
- Calculate the cycle efficiency, and compare it with the simple-cycle efficiency.
- Calculate the heat rate.

2.44 Consider a 600°C , 15-MPa steam cycle with reheat at 2 MPa to 600°C and extraction to a closed feedwater heater at 600 kPa. The FWH condensate is throttled to the condenser at 5 kPa, and the feedwater in the FWH is raised to the condensing temperature of the extraction steam. Neglecting pump work:

- Draw labeled T-s and flow diagrams for this plant.
- Tabulate the enthalpies for each significant state point.
- What is the extraction fraction to the FWH?
- What is the net work?
- What is the thermal efficiency?

(f) What is the heat rate?

2.45 A turbine operates with a 600°C, 7-MPa throttle. Calorimetric measurements indicate that the discharge enthalpy is 3050 kJ/kg at 0.8 MPa. What is the turbine isentropic efficiency?

2.46 A pressurized water-reactor nuclear power plant steam generator has separate turbine and reactor water loops. The steam generator receives high-pressure hot water from the reactor vessel to heat the turbine feedwater. Steam is generated from the feedwater in the turbine loop. The water pressure in the reactor is 15 MPa, and the water temperature in and out of the reactor is 289°C and 325°C, respectively. The plant has one turbine with a single extraction to a closed FWH with condensate throttled to the condenser. Throttle conditions are 300°C and 8 MPa. The extraction and condenser pressures are 100 kPa and 5 kPa, respectively. The reactor-coolant flow rate is 14,000 kg/s. Assume no heat losses in heat exchangers and isentropic turbomachines. Neglect pump work.

- What is the rate of heat transfer from the reactor in MW_t?
- Draw coordinated flow and T-s diagrams that show both loops.
- Determine the extraction mass fraction of the throttle flow rate.
- Determine the cycle net work, heat rate, and thermal efficiency.
- Calculate the steam flow rate.
- Assuming the electrical generator has 97% efficiency, calculate the power output, in MW_e (electric).

2.47 Perform an optimization of the extraction pressure of a Rankine cycle with a 2000-psia saturated-vapor throttle, a 1-psia condenser with a single closed feedwater heater, as in Example 2.9. Compare the optimum extraction temperature given by Equation (2.14) with your results.

2.48 Prepare an optimization study of thermal efficiency with a table and plot of net work and thermal efficiency as a function of reheat pressure level for Example 2.5. Discuss the selection of reheat pressure for this case. How does the reheat pressure used in Example 2.5 compare with your results?

2.49 Solve Exercise 2.25 for reheat and extraction at 200 psia. Compare the extraction mass fraction, net work, thermal efficiency, heat rate, and turbine exit conditions with those of Exercise 2.25.

2.50 Rework Exercise 2.25, accounting for 90% turbine efficiencies and a 10°F terminal temperature difference.

2.51 A 1000°F/2000-psia-throttle high-pressure turbine discharges into a cold reheat line at 200 psia. Reheat is to 1000°F. The low-pressure turbine discharges into the

condenser at 0.5 inches of mercury absolute. Both turbines are 90% efficient. Design the cycle for the use of three feedwater heaters. Draw coordinated T-s and flow diagrams. State and discuss your decisions on the handling of the feedwater heater design.

2.52 A steam turbine receives steam at 1050°F and 3000 psia and condenses at 5 psia. Two feedwater heaters are supplied by extraction from the turbine at pressures of 1000 psia and 200 psia. The low-pressure heater is an open FWH, and the other is closed with its condensate throttled to the open heater. Assuming isentropic flow in the turbine and negligible pump work:

- Sketch accurately labeled and coordinated T-s and flow diagrams for the system, and create a table of temperature, pressure, and enthalpy values for each state.
- What are the extraction flows to each feedwater heater if the throttle mass flow rate is 250,000 pounds per hour?
- How much power, in kW, is produced by the turbine?
- Compare the thermal efficiency of the system with the efficiency if valves of both extraction lines are closed.
- What is the heat rate of the system with both feedwater heaters operative?

2.53 Apply the steady-flow First Law of Thermodynamics to a single control volume enclosing the two turbines in Example 2.7. Show that the same equation is obtained for the turbine work as when the work of individual turbines is summed.

2.54 Apply the steady-flow First Law of Thermodynamics to a single control volume enclosing the two turbines in Example 2.10. Show that the same equation is obtained for the turbine work as when the work of individual turbines is summed.

2.55 Resolve Example 2.7 with 4% pressure drops in the main steam pass and reheat pass through the steam generator. Make a table comparing your results with those of the example to show the influence of the losses on plant performance. Calculate and display the percentage differences for each parameter. Assume turbine throttle conditions are unchanged.

2.56 Draw labeled and coordinated T-s and flow diagrams for a steam power plant with 1000°F / 3000-psia / 2" Hg absolute conditions, assuming isentropic turbomachinery. The plant has reheat at 500 psia to 1100°F. The plant has the following feedwater heaters:

- A closed FWH with extraction at 1000 psia and pumped condensate.
- A closed FWH at 400 psia with condensate throttled into the next-lowest-pressure FWH.
- An open FWH at 20 psia.

Define mass fraction variables. Show mass-flow variable expressions, with arrows indicating mass fractions along the various process paths on the T-s and flow diagrams.

Write equations for conservation of energy for the FWHs that allow you to solve easily for the mass fractions in terms of known state enthalpies and other mass fractions. Indicate a solution method for the mass fractions that involves simple substitution only.

2.57 A pressurized-water nuclear-reactor steam generator has separate turbine and reactor loops. The steam generator linking the two loops cools high-pressure hot water from the reactor vessel and transfers the heat to the turbine feedwater producing steam. The water pressure in the reactor is 2250 psia, and the water temperatures in and out of the reactor are 559°F and 623°F, respectively. The plant has one turbine with a single extraction to an open FWH. Throttle conditions are 555°F and 1100 psia. The extraction and condenser pressures are 100 psia and 1 psia, respectively. The reactor-coolant flow rate is 147,000,000 lb_m/hr. Assume no heat losses in heat exchangers and isentropic turbomachines.

- What is the rate of heat transfer from the reactor, in Btu/hr and in MW_t?
- Draw coordinated flow and T-s diagrams that show both loops with states in their proper relations with respect to each other.
- Determine the extraction mass fraction relative to the throttle flow rate.
- Determine the cycle net work.
- What are the cycle thermal efficiency and heat rate?
- Calculate the turbine-steam flow rate.
- Assuming the electrical generator has 100% efficiency, calculate the turbine power, in Btu/hr and in MW_e.

2.58 Determine the efficiencies of the boiler feed pump and boiler feed pump turbine of the PSO Riverside Station Unit 4/1 (Figure 2.13).

2.59 A Rankine cycle with a single open feedwater heater has a 1040°F and 550-psia throttle. Extraction from the exit of the first turbine (assumed isentropic) is at 40°F of superheat. The second turbine has an efficiency of 85% and expands into the condenser at 5 psia.

- Draw matched, labeled T-s and flow diagrams.
- Accurately calculate and tabulate the enthalpies of all significant states. Neglect pump work.
- What is the feedwater-heater mass fraction relative to the mass flow at the first throttle?
- What is the quality or degree of superheat at the condenser inlet?
- What are the net work, thermal efficiency, and heat rate?
- Estimate the feedwater-heater condensate pump work and its percentage of turbine work.