

CHAPTER FOUR

ASPECTS of STEAM POWER PLANT DESIGN

4.1 Introduction

After studying the fundamental thermodynamic cycles of steam power plants and considering the characteristics and thermochemistry of fuels, it is appropriate to consider the design of the systems and flow processes that are operative in steam plants and other large-scale power production facilities. This chapter will focus first on the processing of several fundamental streams that play a major role in power plant operation. Up to this point, a great deal of attention has been focused on the water path from the point of view of the thermodynamics of the steam cycle. Additional aspects of the water path related to plant design are considered here.

Another fundamental flow in the power plant, the gas stream, includes the intake of combustion air, the introduction of fuel to the air stream, the combustion process, combustion gas cooling in the furnace heat exchange sections, and processing and delivery of the gas stream to the atmosphere through a chimney or stack. A third important stream involves the transportation and preparation of fuel up to the point that it becomes part of the combustion gas.

A major non-physical aspect of power production is the economics of power plant design and operation. This is considered in conjunction with some preliminary design analyses of a prototype plant. Environmental considerations also play an important part in planning and design. The chapter concludes with back-of-the-envelope type calculations that define the magnitudes of the flows in a large plant and identify major design aspects of steam power plants.

4.2 The Water Path

The Liquid-Water-to-Steam Path

Several pumps are employed in the feedwater path of a steam power plant to push the working fluid through its cycle by progressively elevating the pressure of the water from the condenser to above the turbine throttle pressure. These pumps are usually driven by electric motors powered by electricity generated in the plant or by steam turbines powered by steam extracted from the main power cycle.

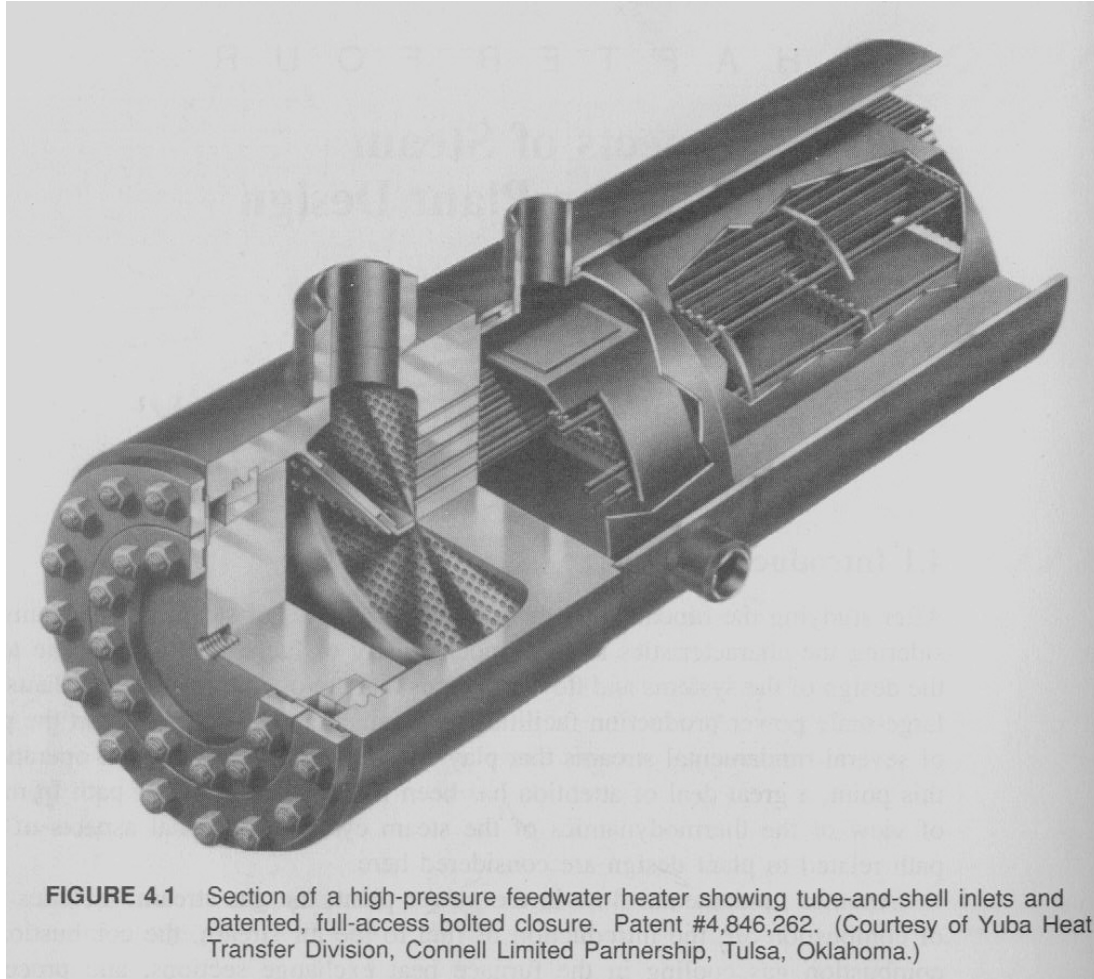

The power requirement of a pump is proportional to the liquid mass-flow rate and the pump work, as given by Equation 2.9, and inversely proportional to the pump efficiency:

$$\text{Power} = m v_{sat} \Delta p / \eta_{\text{pump}} \quad [\text{ft-lb}_f/\text{s} \mid \text{kW}]$$

The pumps are required to overcome frictional pressure losses in water-flow and steam-flow passages, to provide for the pressure differences across turbines, and to elevate the liquid to its highest point in the steam generator. The pump power requirements are typically a small percentage of the gross power output of the plant.

Thus condensate leaving the condenser passes through one or more pumps and feedwater heaters on its way to the steam generator. A typical shell-and-tube closed feedwater heater is shown in Figure 4.1. Normally, feedwater passes through the tubes while extracton steam enters at the top and condenses as it flows over the tubes to the bottom exit.

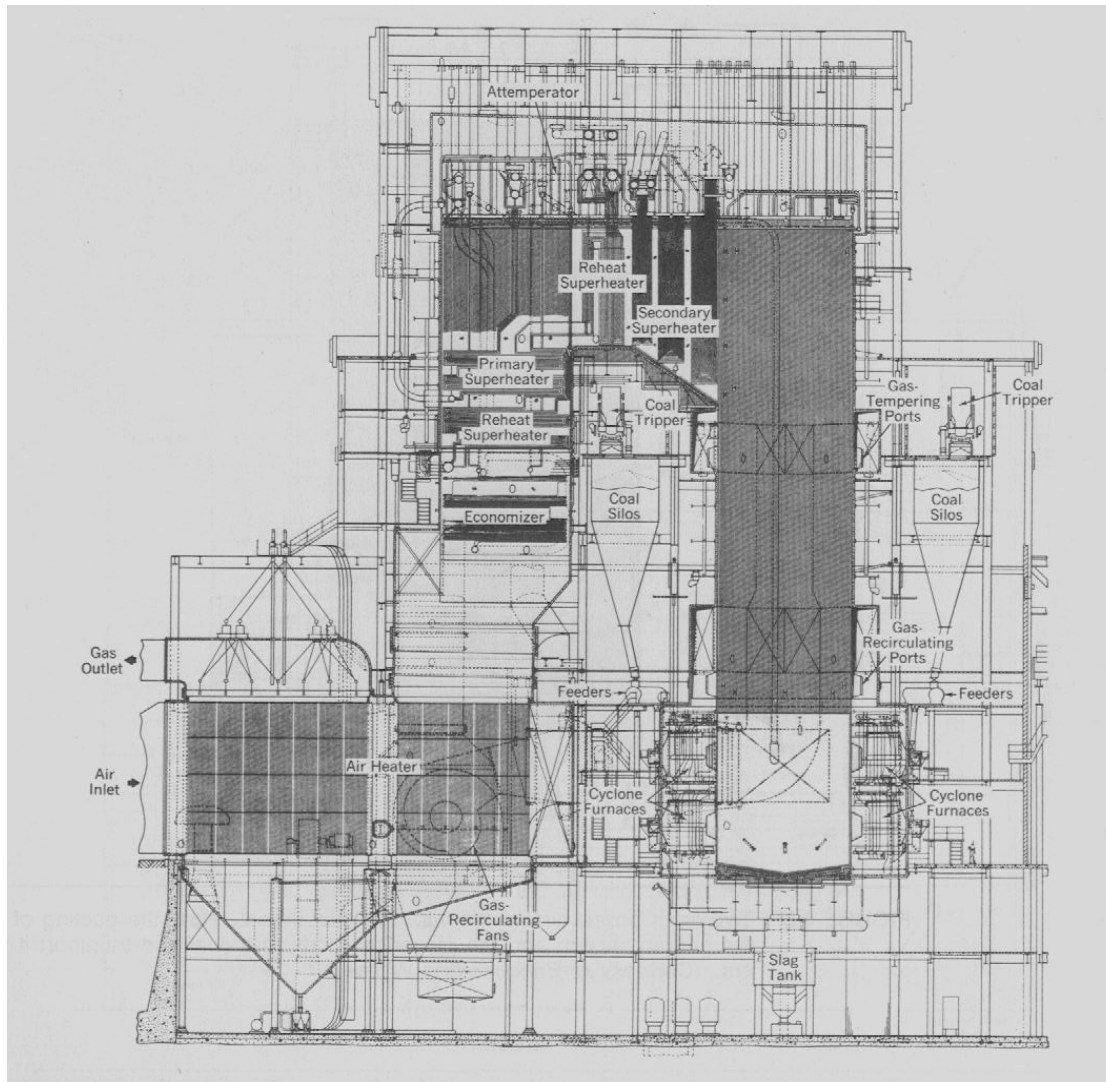
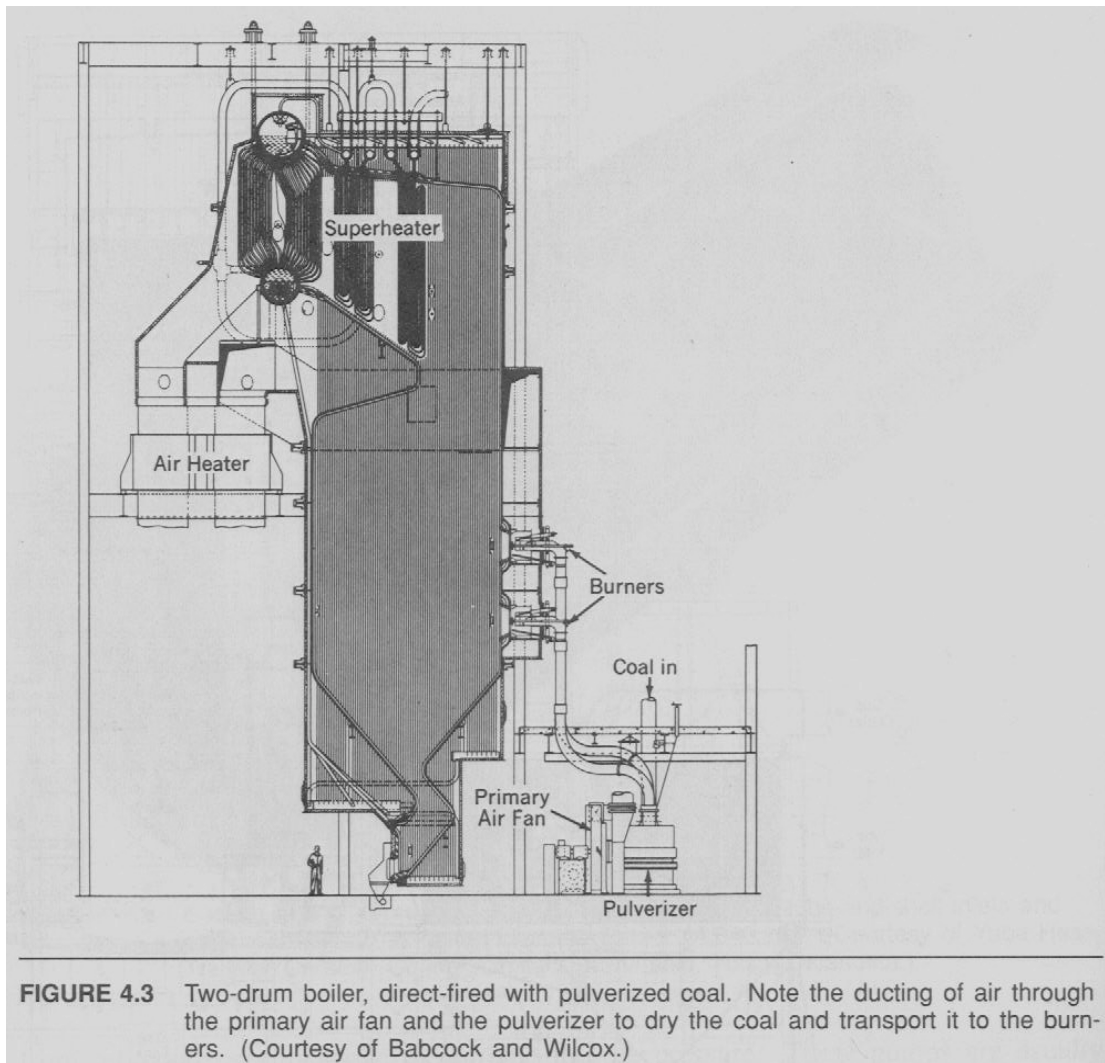

FIGURE 4.2 Universal-pressure boiler with opposed cyclone furnaces and bin system for coal preparation and feeding. Note the absence of steam drums in this supercritical steam generator. (Courtesy of Babcock and Wilcox.)

After passing through the chain of feedwater heaters and pumps, the feedwater enters the steam generator through the economizer. An *economizer* is a combustion-gas-to-feedwater tubular heat exchanger that shares the gas path in a steam generator, as seen in Figure 4.2. The economizer heats the feedwater by transferring to it some of the remaining energy from the cooled exhaust gas before the gas passes to the air heater, the pollution control equipment, and the stack.



Steam Generators

Figures 4.3 and 4.4 show two-drum steam generators in which the design vaporization pressure is below the critical pressure of water. Hot, subcooled liquid feedwater passes from the economizer and through the boiler tube walls to the drum loop located near the top of the steam generator. Liquid water circulates by free convection through the many boiler tubes between the drums until it is vaporized by the hot gas stream flowing over the tubes. A fixed liquid level is maintained in the upper steam drum, where the steam separates from the liquid and passes to the superheater. Solids settle in the bottom of the so-called “mud drum” below it.

A steam drum mounted on a railroad flat car en route to a construction site is shown in Figure 4.5. The many stub tubes around the bottom and on top are to be

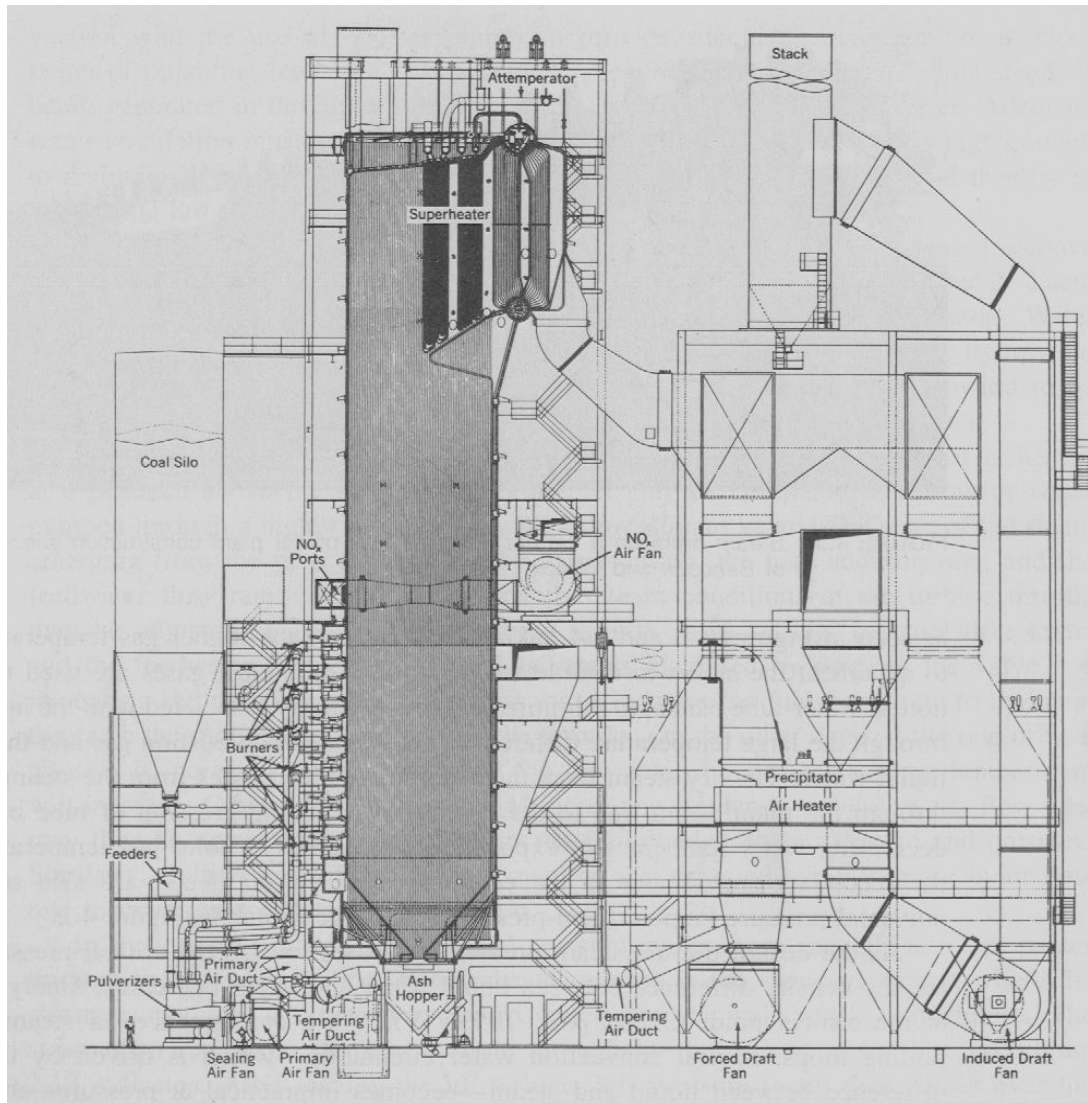

FIGURE 4.4 Arrangement of forced-draft and induced-draft fans for a boiler unit with a capacity of 800,000 lb steam/hr. Note the pneumatic transport of coal from the pulverizers to the burners on six levels of the steam generator. Furnace combustion gas is ducted through the electrostatic precipitator and air heater to the induced-draft fan and stack. (Courtesy of Babcock and Wilcox.)

connected to steam-generating loops and to steam-superheating pipes, respectively, as seen at the top of Figure 4.4. The large pipes on the bottom and the ends are for connection to *downcomers*, which supply recirculated liquid water to various heating circuits in the steam generator.

Steam produced in the steam drum, at a boiling temperature corresponding to the vapor pressure in the drum, passes to superheater tube or plate heat-exchanger banks. The superheater tube banks are located in the gas path upstream of the drum loop, as seen in Figures 4.3 and 4.4, taking advantage of the highest gas temperatures there to superheat the steam to throttle temperature. The hottest gases are used to heat the

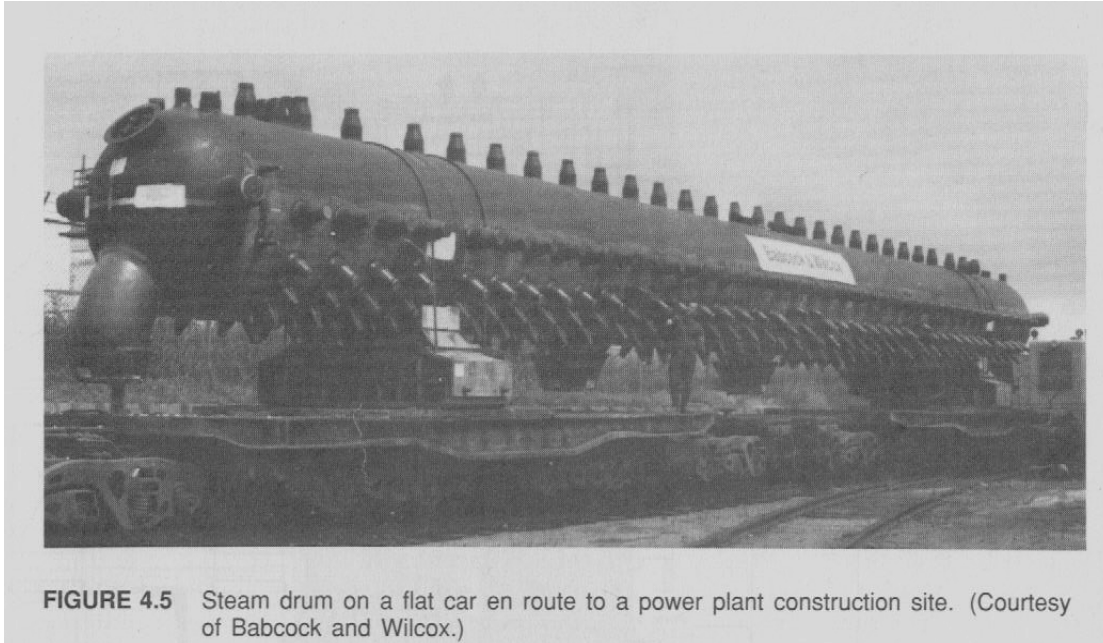

FIGURE 4.5 Steam drum on a flat car en route to a power plant construction site. (Courtesy of Babcock and Wilcox.)

hottest water-tube banks, to minimize the irreversibility associated with the heat transfer through the large temperature differences between the combustion gas and the steam or liquid water. The dry steam from the superheater then passes from the steam generator through the main steam line to the HP turbine. The progression of tube banks, with decreasing water temperatures exposed to successively cooler gas temperatures from the secondary superheater to the economizer to the air heater are also seen in the universal-pressure (supercritical pressure) steam generator in Figure 4.2.

As the design throttle steam pressure increases toward the critical pressure of water, the density difference between liquid water and vapor decreases, finally vanishing at the critical point (3208.2 psia, 705.47°F.). As a consequence, in steam-generator boiling loops, natural convection water circulation—which is driven by the density difference between liquid and steam—becomes impractical at pressures above about 2500 psia. Thus modern high-throttle-pressure power plants use circulating pumps to provide forced to circulation to augment or replace natural circulation of water in the steam generator.

In single-drum steam generators, water flows downward from the steam drum through large pipes called downcomers located outside the furnace wall, then through circulating pumps to headers at the bottom of the steam generator. From the headers, water flows upward in vertical tubes forming the inside of the furnace walls. The water is heated by the furnace gases as it rises, and eventually boils and forms a two-phase flow that returns to the steam drum. There, vapor separates and passes to the superheater.

Steam generators may utilize natural convection flow through downcomers and

vapor-laden upward flow through the tube walls alone or may combine natural convection with the use of booster pumps to provide adequate circulation for a wider range of operating loads. It is important to recognize that at the same time steam is being generated in the boiler, the tube walls are being cooled by the water. Adequate water circulation must be ensured to provide waterside heat transfer rates high enough to maintain tube wall temperatures below their limiting design values and thereby to avoid tube failure.

A once-through *supercritical steam generator*, operates at a throttle pressure above the critical pressure of water as in the Riverside station discussed in Chapter 2. There are no drums and no water recirculation in a once-through steam generator. Water from the economizer passes to the bottom of the furnace, where it starts its upward flow through the furnace tube walls. Steam formed in the tubes flows upward to be collected in headers and mixed to provide a uniform feed to the superheater.

The feedwater passes directly from the liquid to the vapor phase as it is heated at a pressure above the saturation pressure. It may be compared to a flow of water pumped through a highly heated tube with a downstream valve. The state of the steam emerging from the tube depends on the valve setting, the heat addition rate, and the feedwater flow rate. In the same way, the steam conditions at the turbine throttle may be adjusted by changing the turbine throttle valve setting, the fuel firing rate, and the feedwater flow rate. If the flow rate is decreased by closing the throttle valve, it is necessary to decrease the fuel firing rate to maintain the same thermodynamic conditions at the throttle. On the other hand, if the rate of heat transfer is increased without changing the flow rate, the steam discharge temperature will increase. Other adjustments, such as increasing condenser cooling-water flow rate, may then be appropriate to avoid an increase in condenser temperature and pressure. Similarly, an increase in fuel flow rate must be accompanied by an increase in air flow rate to maintain a constant air-fuel ratio.

In cycles with reheat, the reduced-pressure steam from the HP turbines passes through the cold reheat line to the reheater section in the steam generator, where the steam temperature is returned to approximately the original throttle temperature. The steam then returns to the next turbine through the hot reheat steam line, as Figure 2.13 indicates.

After leaving the LP turbine, low-pressure steam then passes over the water-cooled tubes in the condenser and returns to the feedwater heating system as saturated liquid condensate. A condensate pump then raises the pressure of the liquid and transports it to the first low-pressure feedwater heater, where it begins another trip through the cycle.

In order to avoid corrosion, scaling and the deposits of solids along the water path can result in losses of efficiency and unscheduled shutdowns, water of extreme purity is required in the steam cycle. Chemical and filtration processes are employed to ensure that high water quality is maintained, to avoid deterioration or clogging of water path components. An example of the potential deposits when proper water treatment is neglected is seen in Figure 4.6. The deaerator, an open feedwater heater mentioned in

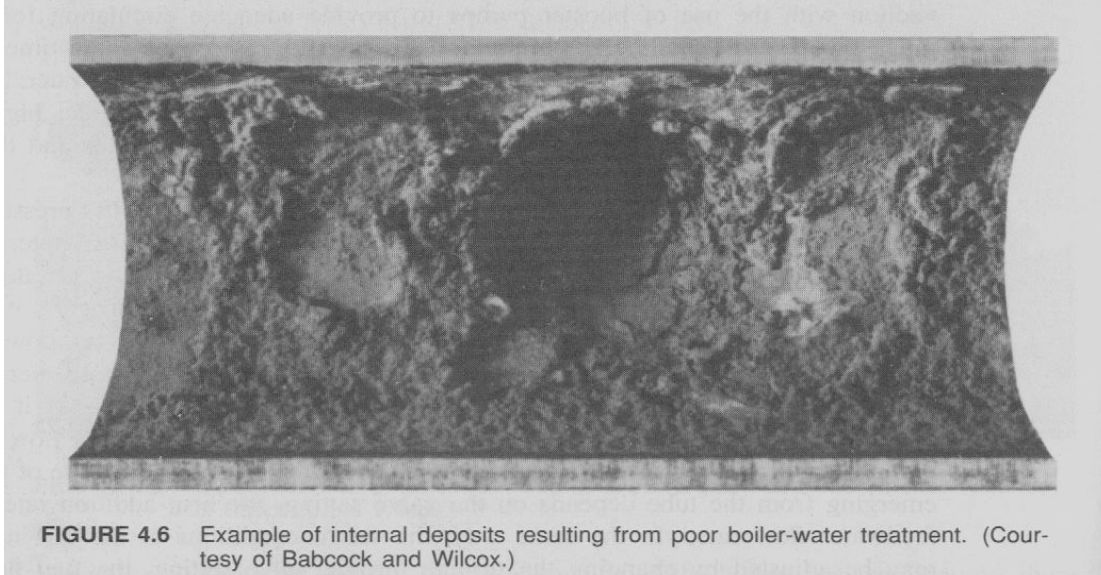

Chapter 2, provides for the removal of noncondensable gases, particularly oxygen, from the working fluid. The deaerator allows noncondensable gases to escape to the atmosphere through a vent condenser, while accompanying steam is retained by condensing it on cool surfaces and returning it to the feedwater heater stream by gravity flow.

The turbine room at the Bull Run coal-burning power plant of the Tennessee Valley Authority (TVA) is shown in Figure 2.3. Electrical generators are seen in the left and right foreground. Behind them, high-pressure turbines on the left are seen joined to low-pressure turbines on the right by two large, vee-shaped crossover steam lines. The side-by-side condensers are seen on either side of the low pressure turbines, a departure from the usual practice of locating the condenser below the low-pressure turbines. Figure 4.7 shows the turbogenerator room at TVA's Brown's Ferry nuclear power plant with a turbine in the foreground.

The Condenser Cooling-Water Loop

The cooling loop, in which water passes through tubes in the condenser removing heat from the condensing steam, is an important water path in large steam plants. This cooling water, clearly separate from the working fluid, is usually discharged into a nearby body of water (a river, or a natural or man-made lake) or into the atmosphere.

Figure 4.8 shows a typical wood-framed, induced-draft cooling tower used to dissipate heat from the condenser cooling water into the atmosphere. The tower is usually located a few hundred yards from a plant. Typically, the cooling water entering the tower is exposed to a flow of air created by upward-blowing fans at the bases of the funnels at the top of the towers. A fraction of the condenser cooling water, which passes over extensive aerating surfaces in the tower, evaporates and exits to the



FIGURE 4.7 Turbine room at TVA's Brown's Ferry nuclear power station. One of the three generators can produce enough electricity to satisfy the residential needs of a small city. (Courtesy of the Tennessee Valley Authority.)

atmosphere, cooling the rest of the water. The remaining chilled water is then returned to the condenser by a cooling-water circulating pump. A continuing supply of liquid makeup water is required for these towers to compensate for vapor loss to the atmosphere.

In areas where large structures associated with power plants are acceptable, large natural-draft cooling towers may be used. Figure 4.9 shows two large natural-draft hyperbolic cooling towers serving a large power plant. The height of these towers, which may reach over 500 feet, creates an upward draft due to the difference in density between the warm air in the tower and the cooler ambient air. Heat from the condenser cooling water warms the air, inducing an upward air flow through the heat transfer surfaces at the base. These towers offer long-term fan-power savings over mechanical draft towers. Under some conditions, these power savings may offset high construction costs of hyperbolic towers.

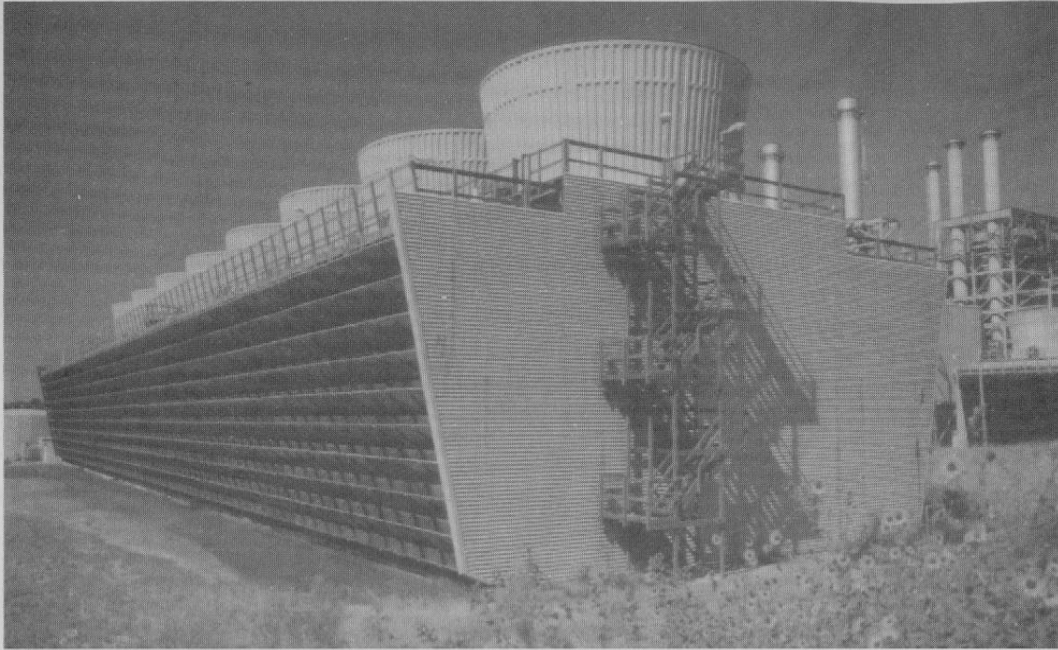

FIGURE 4.8 Wood-framed, induced-draft cooling tower. (Courtesy of the Marley Cooling Tower Co.)



FIGURE 4.9 Hyperbolic natural-draft cooling towers. (Courtesy of the Marley Cooling Tower Co.)

4.3 The Fuel Path for a Coal-Burning Plant

The supply and handling of fuel for a modern coal-burning power plant is a complex and expensive undertaking. In contrast to the relatively simple steady flow of fluid fuels in power plants that consume natural gas and fuel oil, solid-fuel-burning plants offer major and continuing challenges to engineers. The discussion here focuses on these operations and their challenges.

Getting the Coal to the Plant

The source of coal for a plant may be a surface mine or a deep underground mine. Power plants are sometimes located adjacent to mines, where conveyors may provide the only transportation required. This significantly reduces coal transportation costs which otherwise can be higher than the cost of the coal alone. Such plants are called *mine-mouth plants*. A mine-mouth plant may be an attractive option if its selection does not result in significant transmission costs to bring the electrical power to distant load centers where the utilities' customers are located.

Today the power plant and coal mines are likely to be a considerable distance apart, perhaps a thousand miles or more. The most widely used modern transportation link between mine and plant is the *unit train*, a railroad train of about a hundred cars dedicated to transporting a bulk product such as coal. Although *slurry pipelines* (a slurry is a fluid mixture of solid lumps and liquid, usually water, which can be pumped through pipes by continuous motion) sometimes offer attractive technical solutions to coal transport problems, economic and political forces frequently dictate against their use. Dedicated truck transport is an occasional short-haul solution, and barges are sometimes used for water transport. Here, we will focus on unit trains.

Several unit trains may operate continuously to supply a single plant. Trains carrying low-sulfur coal from Wyoming, Montana, and the Dakotas supply coal to plants as distant as Michigan, Illinois, and Oklahoma. This strange situation, in which utilities located in states with large quantities of coal purchase coal from distant states, was a response to pollution control requirements. It was preferred to purchase low-sulfur coal from a distant state rather than pay a high price for sulfur removal equipment (perhaps 10% of the cost of the plant construction), some of which has a reputation for unreliability. In response to such choices, the Oklahoma legislature passed a law requiring utilities to burn at least 10% Oklahoma coal in their coal-burning steam generators. Such mixing of small quantities of high-sulfur coal with low-sulfur coal is an expedient to protect local businesses and to spread out resource utilization geographically.

New plants, however, no longer have the option to choose low-sulfur coal or sulfur removal equipment. "Best available control technology," BACT, has become the rule. The Environmental Protection Agency now requires new plants to have scrubbers (sulfur removal equipment) even if the plants use low-sulfur coal, and they are required to employ the currently most effective pollution control technology.

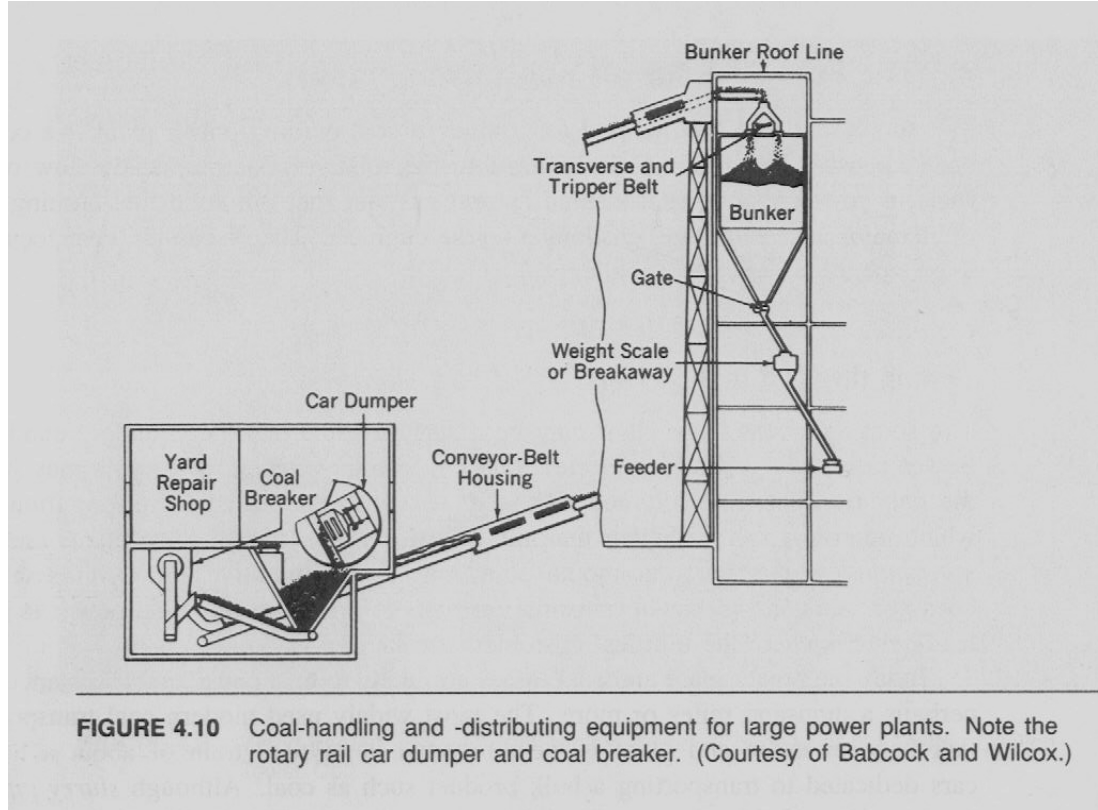

Coal Unloading and Storage

On arrival at the plant, the unit train passes through an unloading station. Some coal cars have doors on the bottom that open and dump their load to a conveyor below. Others have couplings between cars that allow the rotation of individual cars about their coupling-to-coupling axis, by a dumping machine, without detachment from the train, as seen in Figure 4.10. The figure shows a breaker in the dumping facility that reduces large coal chunks to a smaller, more uniform size for transport on a belt conveyor. The under-track conveyor at the unloading station then carries the newly arrived coal up and out to a bunker or to a stacker-reclaimer in the coal yard as seen in Figure 4.11. The stacker-reclaimer either feeds the coal through a crusher to the plant or adds it to the live storage pile.

A permanent coal storage pile sufficient to supply the plant for several months is usually maintained. While the first-in-first-out approach common in handling perishable goods seems logical, a *first-in-last-out* storage system is usually used. A primary reason for this approach is the hazard and expense of coal pile fires, which can occur due to spontaneous combustion. Once a stable storage pile is achieved by packing and other treatment to restrict air access, it is usually not disturbed unless coal must be withdrawn by the stacker-reclaimer to satisfy unusual demands caused by labor strikes, extreme weather, rail accidents, or the like.

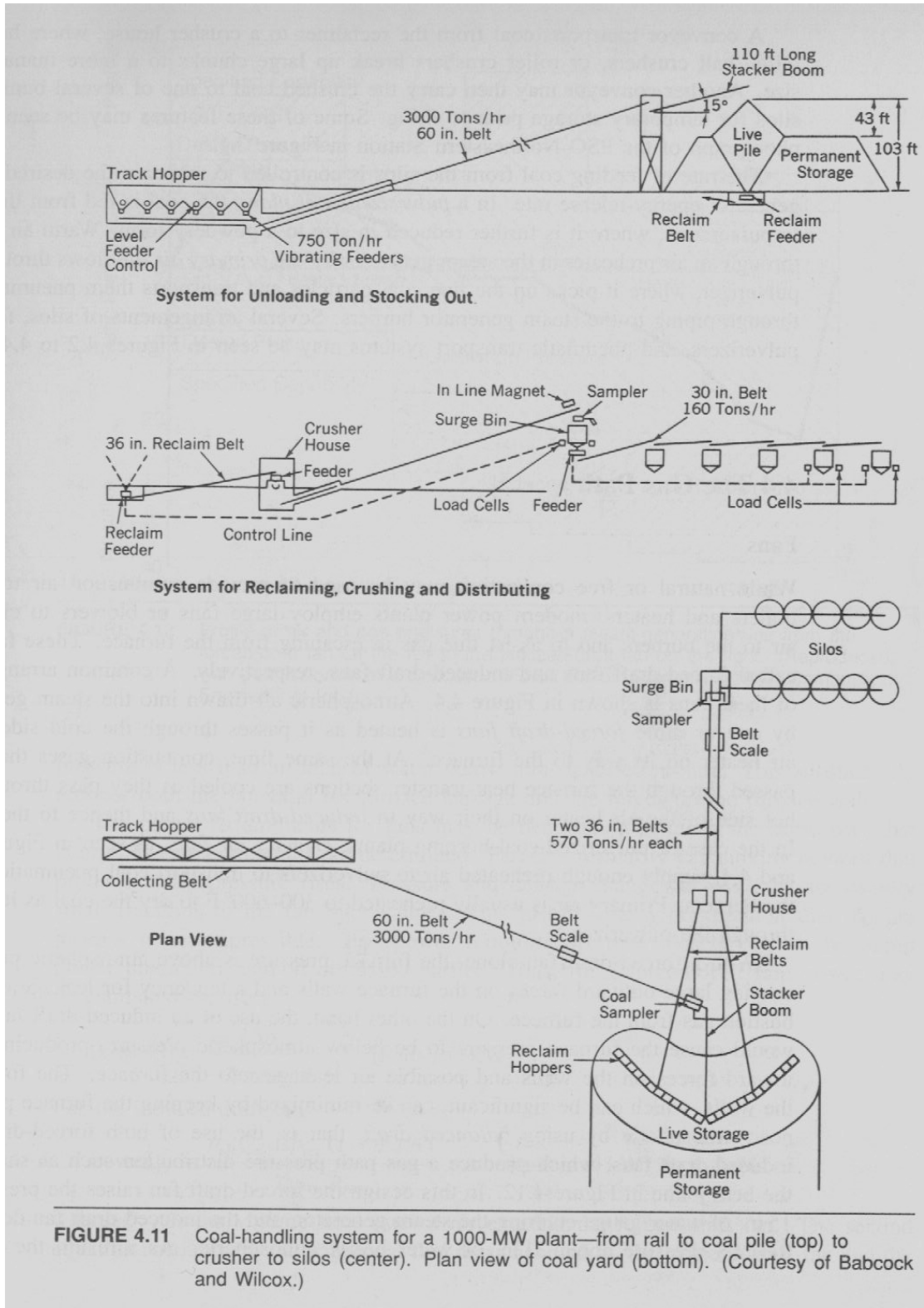

FIGURE 4.11 Coal-handling system for a 1000-MW plant—from rail to coal pile (top) to crusher to silos (center). Plan view of coal yard (bottom). (Courtesy of Babcock and Wilcox.)

A conveyor transports coal from the reclaimer to a crusher house, where hammer mills, ball crushers, or roller crushers break up large chunks to a more manageable size. Another conveyor may then carry the crushed coal to one of several bunkers or silos for temporary storage prior to firing. Some of these features may be seen in the photograph of the PSO Northeastern Station in Figure 2.1.

The rate of feeding coal from the silos is controlled to maintain the desired steam generator energy-release rate. In a *pulverized-coal plant*, the coal is fed from the silos to pulverizers, where it is further reduced in size to a powdery form. Warm air drawn through an air preheater in the steam generator by the *primary air fan* flows through the pulverizer, where it picks up the fine coal particles and transports them pneumatically through piping to the steam generator burners. Several arrangements of silos, feeders, pulverizers, and pneumatic transport systems are seen in Figures 4.2 to 4.4.

4.4 The Gas Path

Fans

While natural or free convection may be used to provide combustion air to small boilers and heaters, modern power plants employ large fans or blowers to circulate air to the burners and to assist flue gas in escaping from the furnace. These fans are called *forced-draft fans* and *induced-draft fans*, respectively. A common arrangement of these fans is shown in Figure 4.4. Atmospheric air drawn into the steam generator by one or more forced-draft fans is heated as it passes through the cold gas side of an air heater on its way to the furnace. At the same time, combustion gases that have passed through the furnace heat transfer sections are cooled as they passed through the hot side of the air heater on their way to induced-draft fans and thence to the stack. In the case of pulverized-coal-burning plants, *primary air fans*, as seen in Figures 4.3 and 4.4, supply enough pre-heated air to pulverizers to transport coal pneumatically to the burners. Primary air usually pre-heated to 300-600°F to dry the coal as it passes through the pulverizer.

With a forced-draft fan alone, the furnace pressure is above atmospheric pressure, causing large outward forces on the furnace walls and a tendency for leakage of combustion gas from the furnace. On the other hand, the use of an induced-draft fan alone would cause the furnace pressure to be below atmospheric pressure, producing large inward forces on the walls and possible air leakage into the furnace. The forces on the walls, which can be significant, can be minimized by keeping the furnace pressure near atmospheric by using *balanced draft*, that is, the use of both forced- and induced-draft fans, which produce a gas path pressure distribution such as shown by the heavy line in Figure 4.12. In this design the forced-draft fan raises the pressure to 15 in. of water gauge entering the steam generator, and the induced-draft fan depresses its inlet pressure about 21 in. of water below atmospheric. As a result, the furnace inside-wall pressure is less than an inch of water below atmospheric. This substantially reduces both the potential for furnace leakage and the forces on the furnace walls.

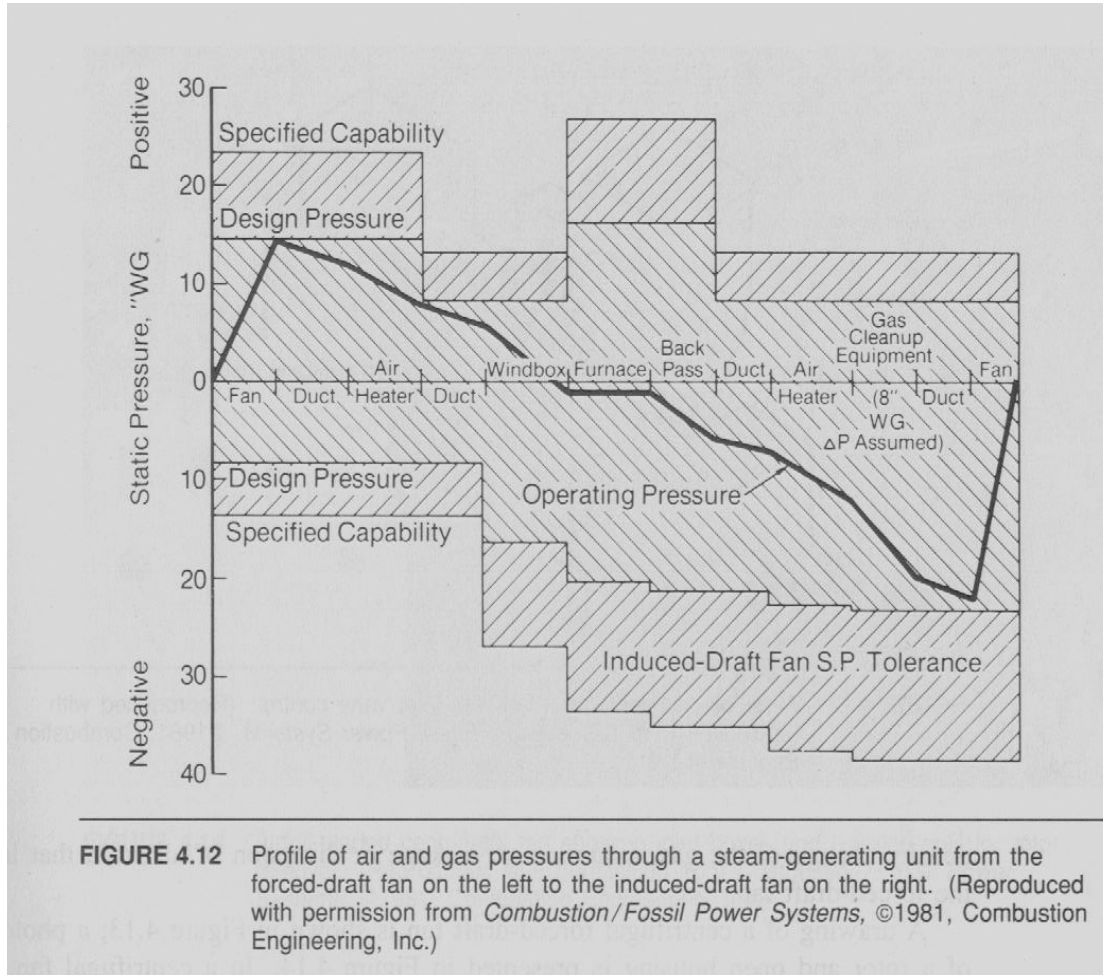

The power requirements for fans may be determined in much the same way that pump power requirements are determined. Fans are primarily gas-moving devices that produce small pressure rises. Pressure and density changes across fans are usually small fractions of the fan inlet values. This justifies the approximation that the fan process is incompressible. Fan power requirements then closely follow the pump power prediction method discussed earlier. Thus, for a forced-draft fan, power may be estimated by using

$$\text{Power}_{\text{FD}} = Q_{\text{air}} \Delta p_{\text{air}} / \eta_{\text{FDfan}} \quad [\text{ft-lb}_f/\text{s} \mid \text{kW}]$$

For the induced-draft fan

$$\text{Power}_{\text{ID}} = \rho_{\text{air}} Q_{\text{air}} \Delta p_{\text{gas}} (1 + F/A) / \rho_{\text{gas}} \eta_{\text{FDfan}} \quad [\text{ft-lb}_f/\text{s} \mid \text{kW}]$$

where Q_{air} is the volume flow rate of air entering the forced-draft fan. The second equation accounts for the additional fuel mass handled by the induced-draft fan and the

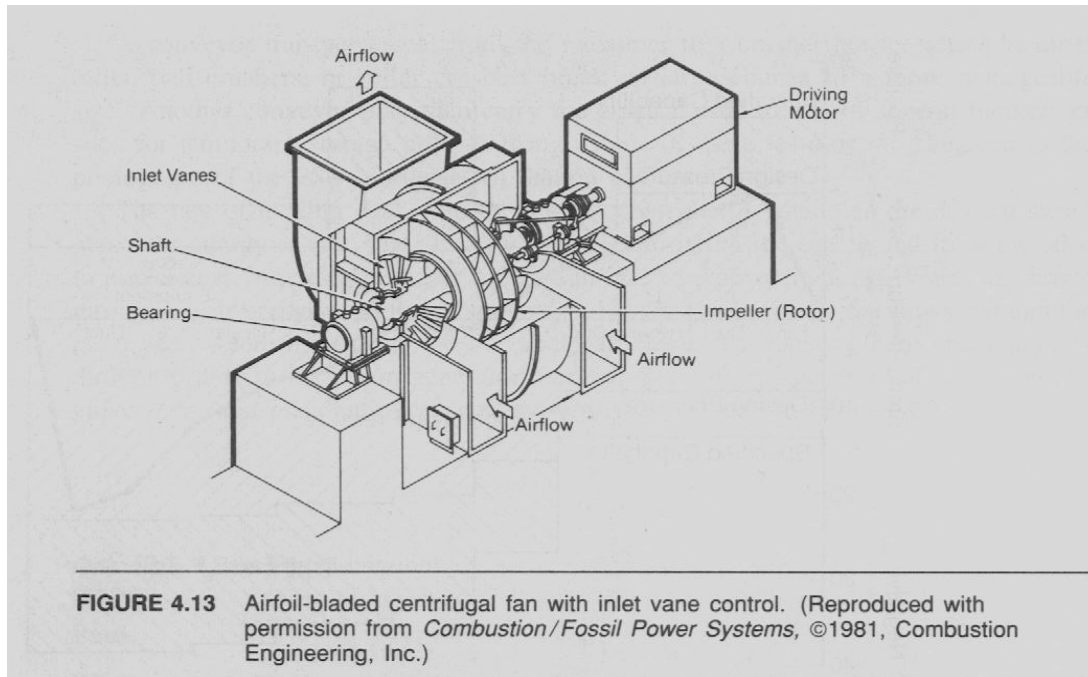

density of the gas leaving the furnace, assuming no leakage or diversion of air from that leaving the forced-draft fan.

The drawing of a centrifugal forced-draft fan is shown in Figure 4.13; a photograph of a rotor and open housing is presented in Figure 4.14. In a centrifugal fan, air is spun by the rotor blades, producing tangential motion and pressure rise and leaving behind a vacuum for air to flow in along the axis of the fan. If the fan entrance is open to the atmosphere, its exhaust is pressurized; if its exhaust is atmospheric, its entrance pressure is below atmospheric. Fans typically do not produce large pressure rises but do produce large flows of gases.

A diagram of an axial-flow fan designed for induced-draft use is shown in Figure 4.15. Figure 4.16 presents a photo of the same type of fan. Induced-draft fans must be able to withstand high-temperature service and erosion due to airborne particulates. Large *electrostatic precipitators* located upstream of the induced-draft fans remove most of the flyash by inducing a static charge on the flowing particles and collecting them on plates of opposite charge. The plates are periodically rapped mechanically to free ash deposits that drop to the bottom of the precipitator and are collected and removed. Figure 2.1 shows electrostatic precipitators, to the right of the steam generator. The large structure behind the fans, air heater, and ducting and below the stack in Figure 4.4 is an electrostatic precipitator.

Air Preheaters

The air leaving the forced-draft fan usually flows through an air preheater to a windbox around the furnace and then to the burners. A *Ljungstrom rotary air preheater*, used

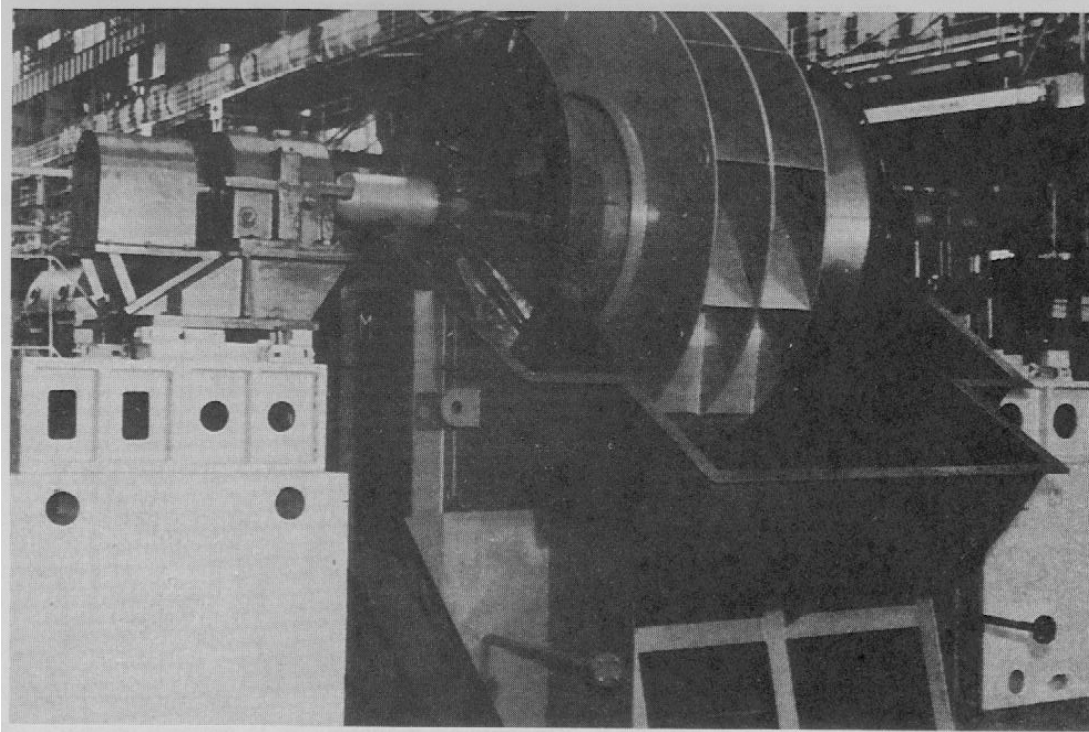

FIGURE 4.14 Airfoil-bladed centrifugal fan showing inlet boxes and housing split for rotor removal. (Reproduced with permission from *Combustion/Fossil Power Systems*, ©1981, Combustion Engineering, Inc.)

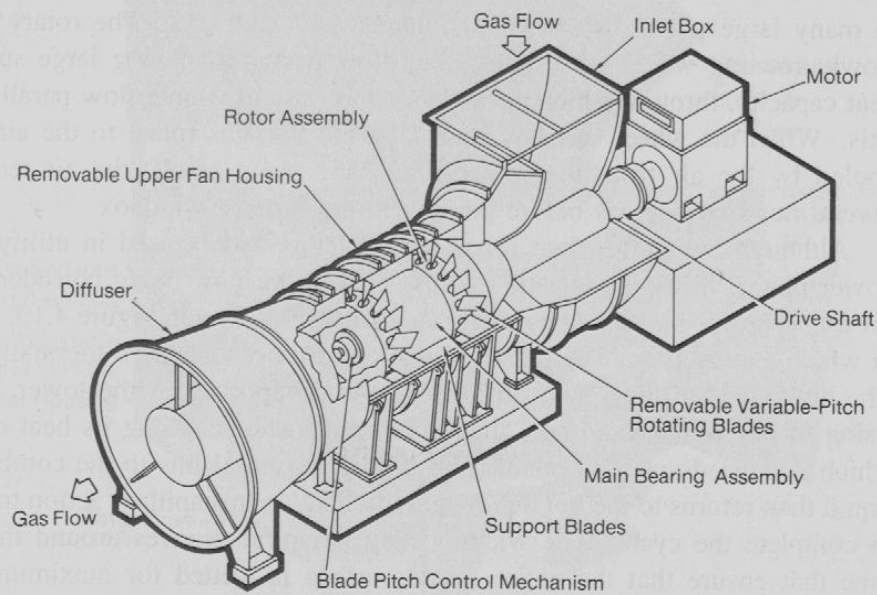

FIGURE 4.15 Two-stage variable-pitch axial-flow fan for induced-draft service. (Reproduced with permission from *Combustion/Fossil Power Systems*, ©1981, Combustion Engineering, Inc.)

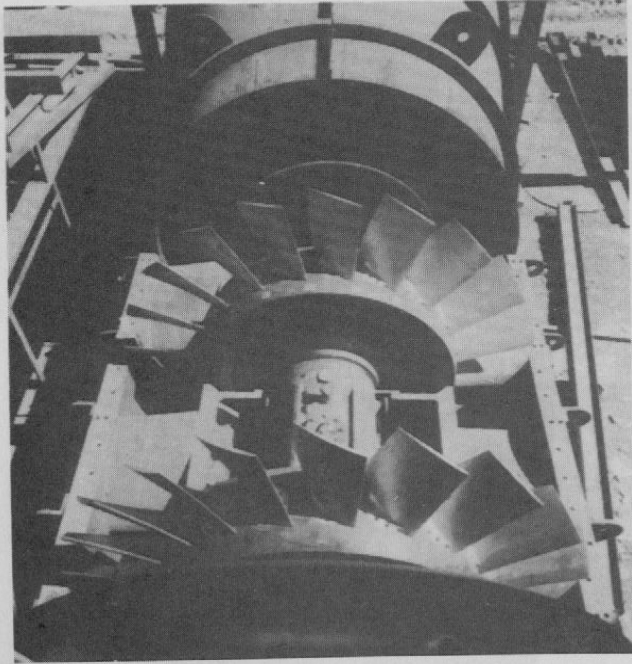

FIGURE 4.16 Construction view of two-stage axial-flow fan with upper housing not yet in place. (Reproduced with permission from *Combustion/Fossil Power Systems*, ©1981, Combustion Engineering, Inc.)

in many large plants, is shown in Figures 4.17 and 4.18. The rotary air heater is a slowly rotating wheel with many axial-flow passages, having large surface area and heat capacity, through which air and flue gas pass in counterflow parallel to the wheel axis. When the wheel surfaces heated by the flue gas rotate to the air side, they are cooled by the air from the forced-draft fan. As result, the air temperature rises several hundred degrees before passing to the furnace windbox.

Although the Ljungstrom rotary air heater is widely used in utility and industrial power plants, heat-pipe air and process heaters are now being considered and applied for use in power plants and industry. A *heat pipe*, shown in Figure 4.19, is a sealed tube in which energy is transported from one end to the other by a thermally driven vapor. The heat-pipe working fluid absorbs heat and vaporizes at the lower, hot end. After rising to the higher, cold end, the vapor condenses, releasing its heat of vaporization, which is carried away by conduction and convection through external fins to the combustion air. The liquid then returns to the hot end by gravity and/or by capillary action through wicking, to complete the cycle. The wicking may be spiral grooves around the inside of the tube that ensure that the entire inside surface is wetted for maximum heat transfer. The wicking in the cold section is particularly important, because it provides increased surface area that increases inside-gas heat transfer rates. The outside the tube is usually finned to provide adequate external heat transfer rates, both from the flue gas and to the incoming air.

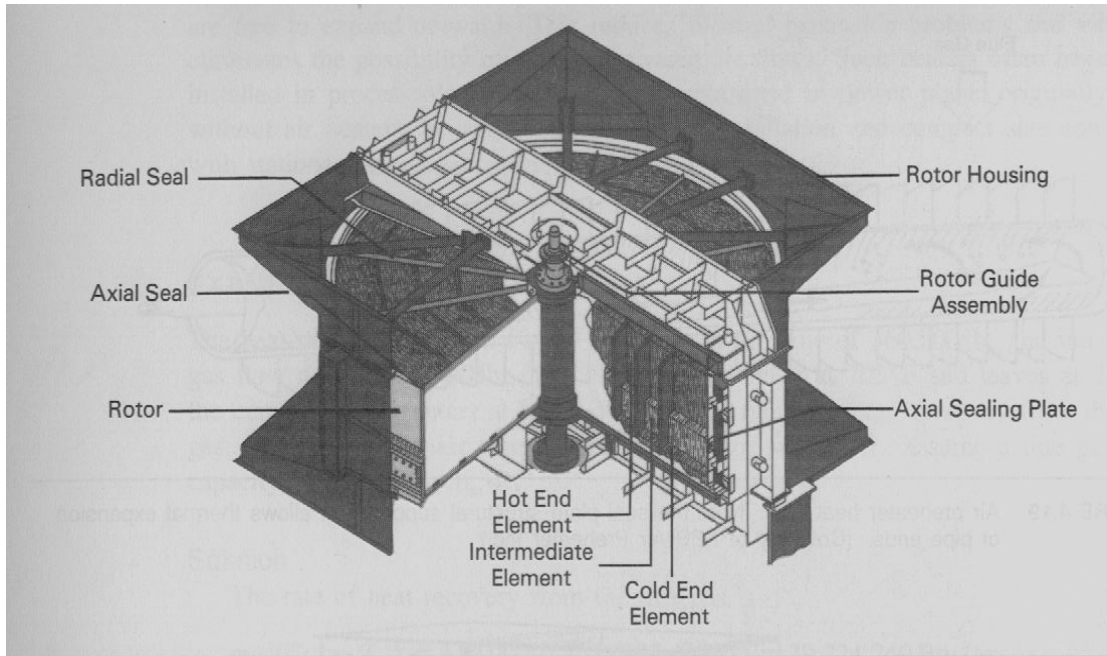

FIGURE 4.17 Cutaway diagram of a Ljungstrom air preheater. (Courtesy of ABB Air Preheater Inc.)

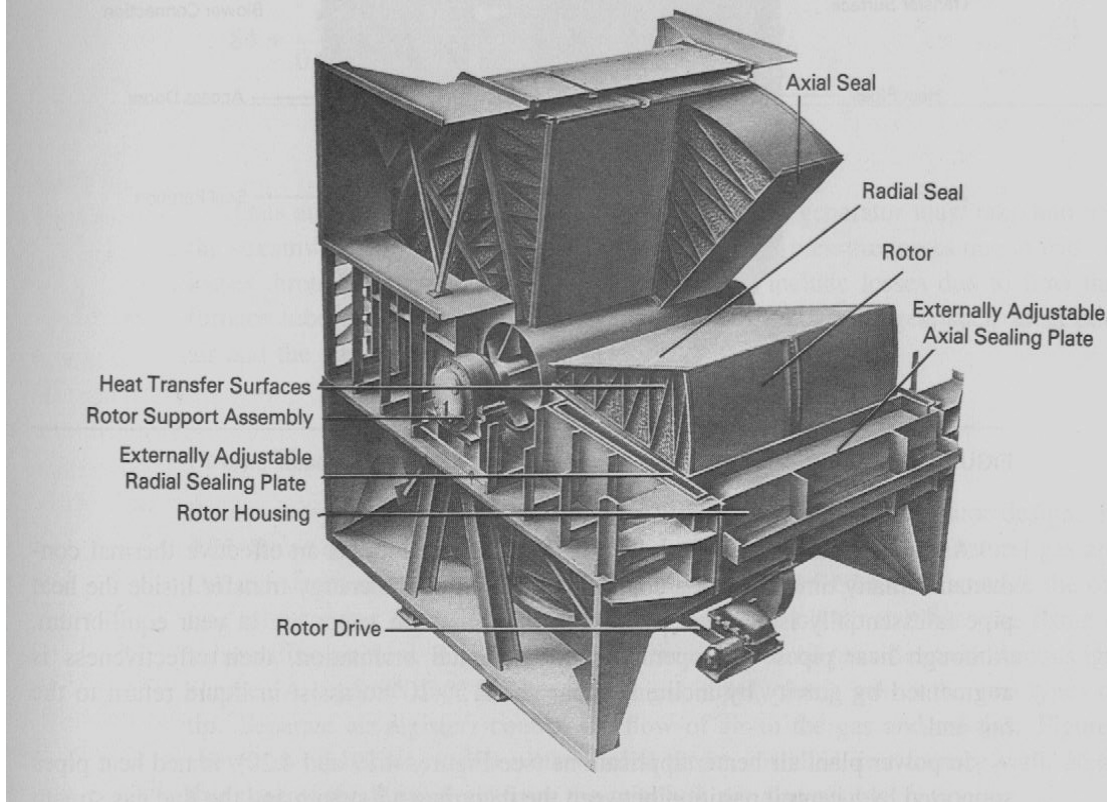

FIGURE 4.18 Horizontal-axis Ljungstrom air preheater. (Courtesy of ABB Air Preheater Inc.)

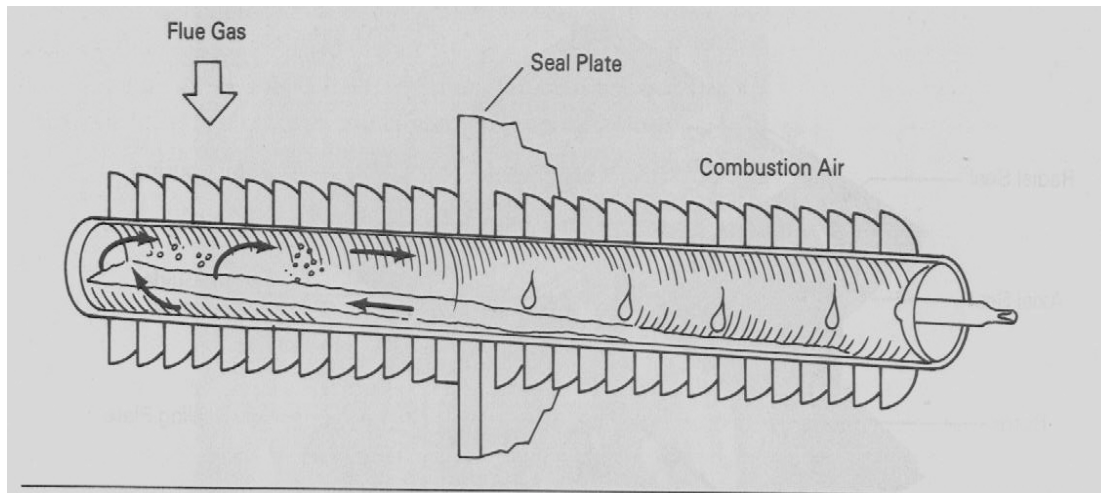

FIGURE 4.19 Air preheater heat pipe. Note the seal plate structural support that allows thermal expansion of pipe ends. (Courtesy of ABB Air Preheater Inc.)

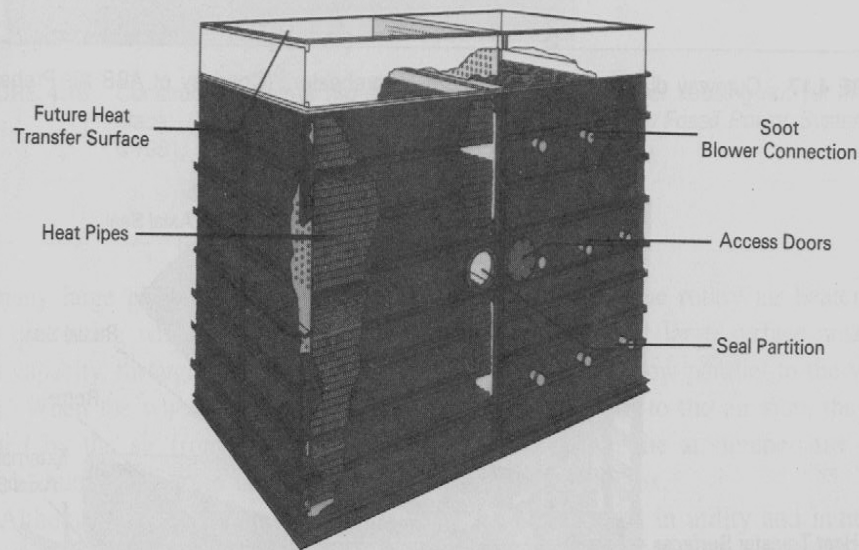

FIGURE 4.20 Heat-pipe air preheater. (Courtesy of ABB Air Preheater Inc.)

As a heat transfer device, a well-designed heat pipe has an effective thermal conductance many times that of a copper rod. Note that the energy transfer inside the heat pipe is essentially isothermal, since the liquid and the vapor are in near equilibrium. Although heat pipes will operate in a horizontal orientation, their effectiveness is augmented by gravity by inclining them about 5° – 10° to assist in liquid return to the hot end.

In power plant air heater applications (see Figures 4.19 and 4.20), finned heat pipes supported by a central partition between the incoming air stream and the flue gas

stream are free to expand outward. This reduces thermal expansion problems and virtually eliminates the possibility of leakage between the flows. Such heaters often have been installed in process plants and have been retrofitted in power plants originally built without air heaters, because of their ease of installation and compact size compared with stationary tubular air heaters.

EXAMPLE 4.1

The heat-pipe air heater in Figure 4.20 has an air flow of 360,800 lb_m/hr and a flue gas flow rate of 319,000 lb_m/hr. The flue gas enters at 705°F and leaves at 241°F; the combustion air enters at 84°F. What is the rate of energy recovery from the flue gas, and what is the air temperature entering the windbox? Assume a flue gas heat capacity of 0.265 Btu/lb_m-R.

Solution

The rate of heat recovery from the flue gas is

$$mc_p (T_{out} - T_{in}) = 319,000(0.265)(705 - 241) = 39,224,240 \text{ Btu/hr}$$

The air temperature is then

$$84 + 39,224,240 / [(0.24)(360,800)] = 537^\circ\text{F}$$

An analysis of the gas flow through a steam generator must take into account the streamwise pressure rise through the fans and pressure losses due to friction and losses through flow restrictions and turns. These include losses due to flow through furnace tube and plate heat exchanger banks and other passages, such as in both the air and the gas passes through the air heater.

Power Plant Burners

Burner design depends on the choice of fuel and the steam generator design. Figure 4.21 shows a burner designed for forced-draft applications burning natural gas and oil. Oil and steam under pressure are mixed in the central feed rod to atomize the oil to a fine mist coming out of the oil tip. The cone at the oil tip stabilizes the flame in the surrounding air flow. The gas pilot next to the oil feed rod provides a continuous ignition source. A separate duct for the natural gas supply feeds gas to the two types of gas tip. Separate air registers control the flow of air to the gas and oil tips. Figure 4.22 shows an oil burner, with a water-cooled throat, installed in a furnace wall. Registers that control the flow of air from the windbox are also visible.

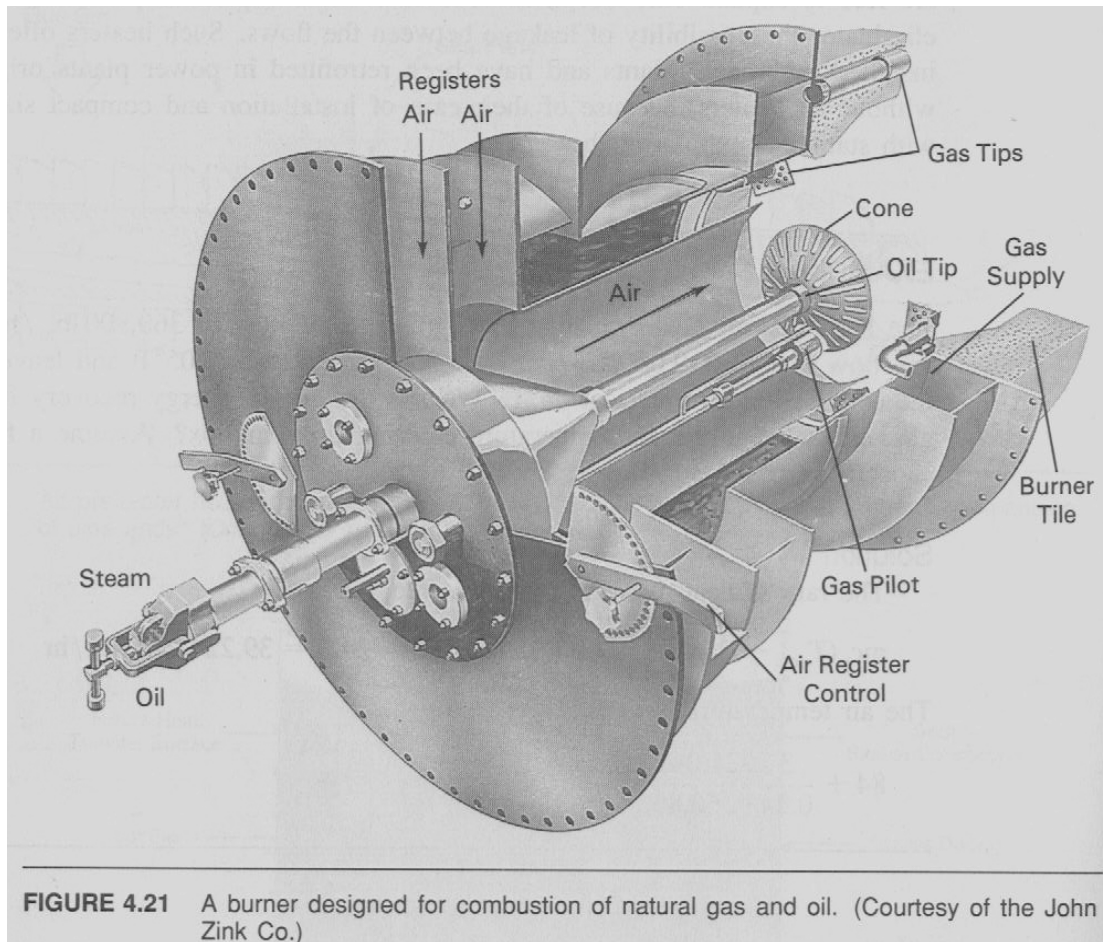

FIGURE 4.21 A burner designed for combustion of natural gas and oil. (Courtesy of the John Zink Co.)

In the case of the pulverized-coal plant, *primary air* flows through the pulverizer and carries the fuel directly to the burners (Figure 4.23). *Secondary* (and sometimes *tertiary*) *air* helps to control the temperature of the control nozzle and of the furnace wall, and mixes with the combustion gases to provide for essentially complete combustion of the fuel. Features of a burner designed for pulverized-coal firing in planar furnace walls are shown in Figure 4.24. Note that the secondary air flow through the windbox registers helps to cool the nozzle through which the coal and the primary air flow.

Another approach to burning pulverized coal uses corner burners in *tangentially fired* steam generators. A plan view of such a furnace is shown in Figure 4.25. The burners induce a circular motion, in the horizontal plane, on the upward-rising combustion gases, promoting vigorous mixing, which hastens completion of combustion in the furnace. For control purposes, the corner burners can be tilted in the vertical direction to adjust the furnace heat transfer distribution.

A *cyclone furnace* type of burner installation, used for burning slagging coals (those that form liquid ash, or slag, at moderate temperatures) in steam generators, is shown in Figure 4.2. The cyclone furnace is a cylindrical furnace with very large

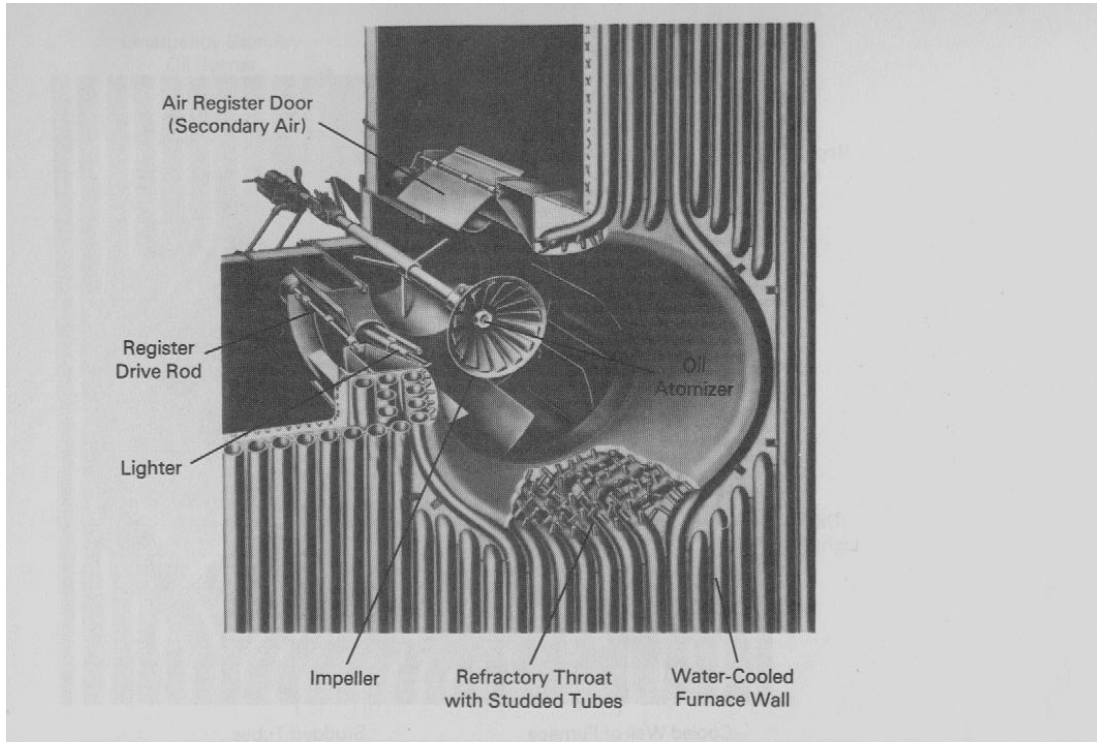

FIGURE 4.22 Water tube wall installation of an oil burner. (Courtesy of Babcock and Wilcox.)

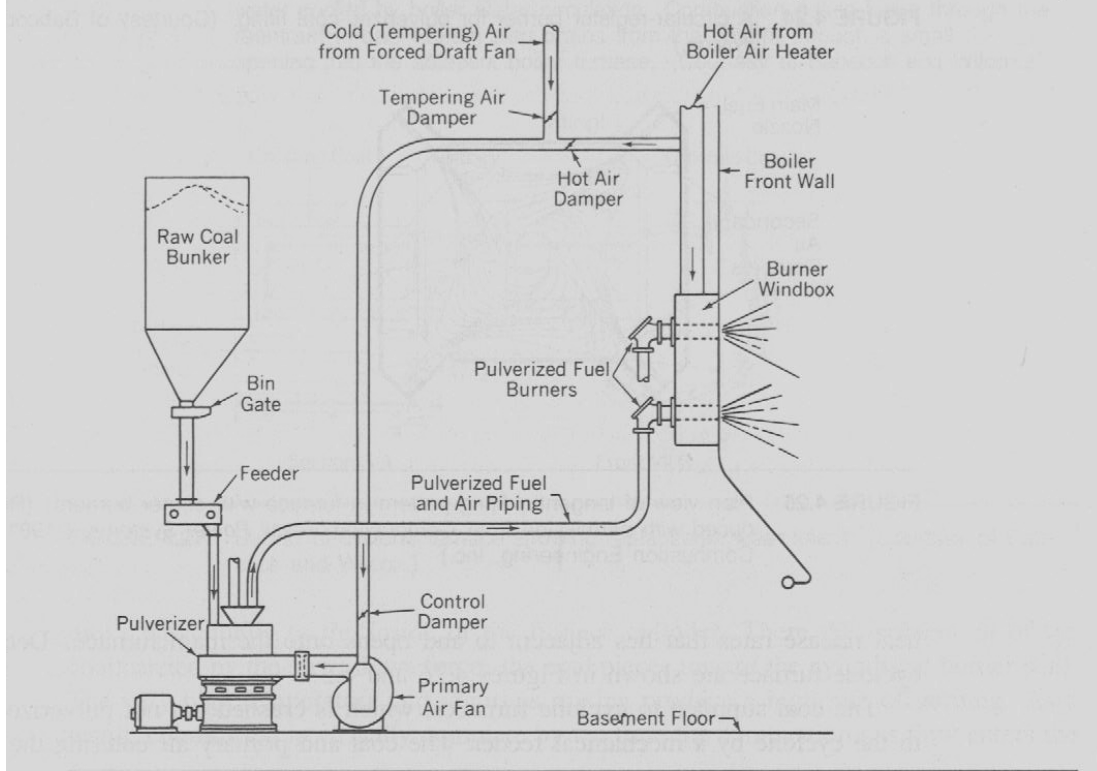

FIGURE 4.23 Direct-firing system for pulverized coal. (Courtesy of Babcock and Wilcox.)

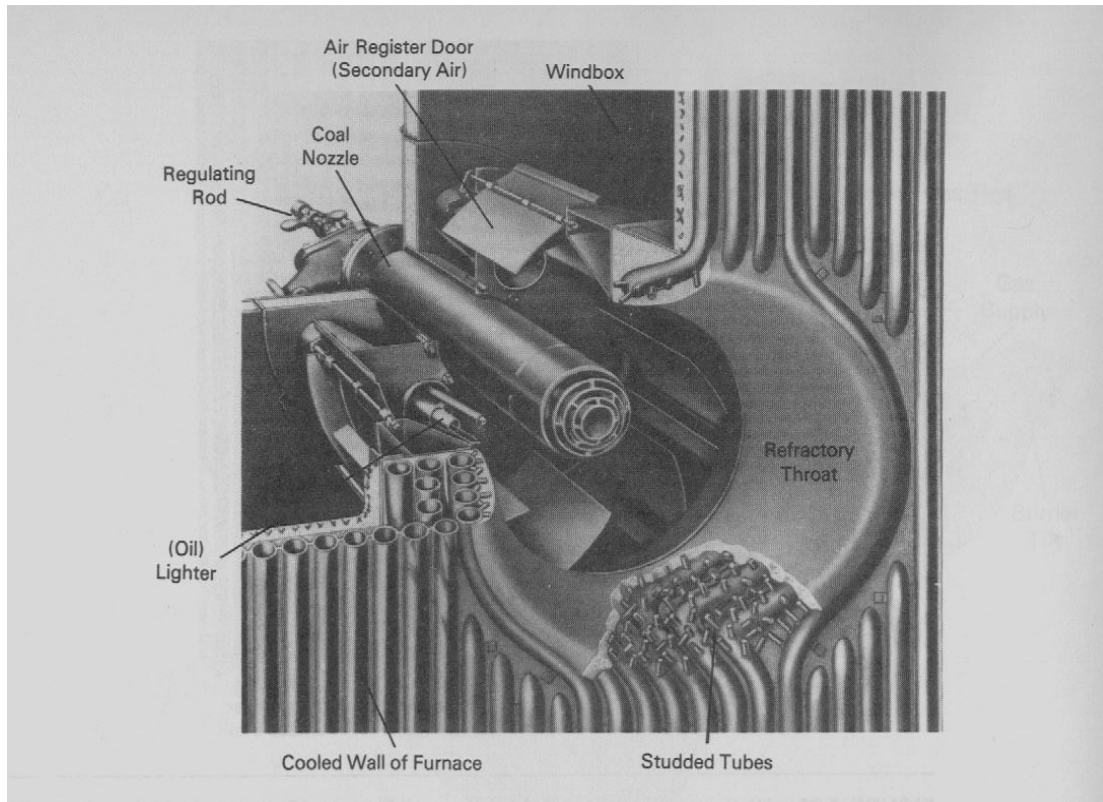

FIGURE 4.24 A circular-register burner for pulverized-coal firing. (Courtesy of Babcock and Wilcox.)

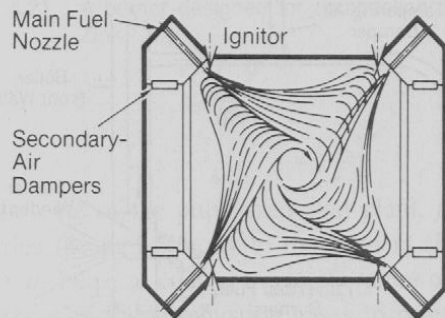

FIGURE 4.25 Plan view of tangential-firing pattern in furnace with corner burners. (Reproduced with permission from *Combustion/Fossil Power Systems*, ©1981, Combustion Engineering, Inc.)

volumetric heat release rates that lies adjacent to and opens onto the main furnace. Details of a cyclone furnace are shown in Figures 4.26 and 4.27.

The coal supplied to cyclone furnaces, which is crushed but not pulverized, is fed to the cyclone by a mechanical feeder. The coal and primary air entering the cyclone

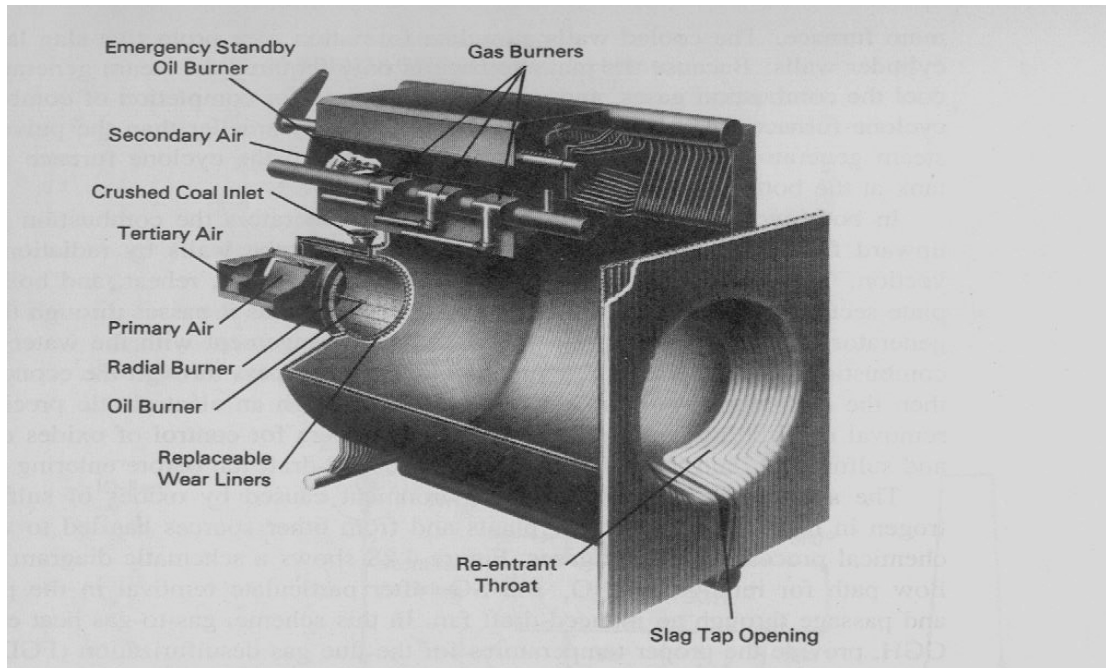

FIGURE 4.26 The cyclone furnace is in the form of a horizontal cylinder that is completely water cooled by boiler water circulation. Combustion gases leave through the reentrant throat. Molten slag drains from the bottom through a small opening into the adjacent boiler furnace. (Courtesy of Babcock and Wilcox.)

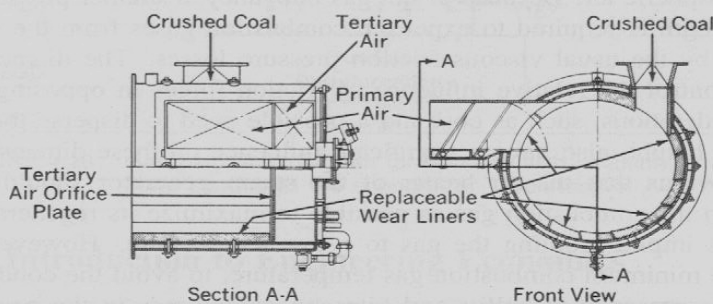

FIGURE 4.27 Burner of cyclone furnace showing replaceable wear liners. (Courtesy of Babcock and Wilcox.)

move tangentially to the inside of the furnace cylinder. There the momentum of the coal carried by the swirl flows forces the coal pieces toward the cylindrical burner wall. The very high temperature and vigorous mixing produce a high rate of burning. As a result, combustion is virtually complete by the time the combustion gas flow enters the

move tangentially to the inside of the furnace cylinder. There the momentum of the coal carried by the swirl flows forces the coal pieces toward the cylindrical burner wall. The very high temperature and vigorous mixing produce a high rate of burning. As a result, combustion is virtually complete by the time the combustion gas flow enters the

main furnace. The cooled walls stimulate formation of a protective slag layer on the cylinder walls. Because the main furnace is only required for steam generation and to cool the combustion gases, and not to provide time for completion of combustion, the cyclone furnace steam generator can be significantly smaller than the pulverized-coal steam generator. A steady flow of slag drains from the cyclone furnace into a slag tank at the bottom of the main furnace.

In both cyclone and pulverized-coal steam generators the combustion gases flow upward from the burners, transferring heat to the tube walls by radiation and convection. The cooling gases then flow through superheater, reheat, and boiler tube or plate sections. The combustion gas temperature drops as it passes through these steam generator sections in essentially a counterflow arrangement with the water flow. The combustion gases undergo their final cooling as they pass through the economizer and then the air preheater. From there they pass through an electrostatic precipitator for removal of airborne particles and through scrubbers for control of oxides of nitrogen and sulfur (NO_x and SO_x) and through an induced-draft fan before entering the stack.

The serious degradation of the environment caused by oxides of sulfur and nitrogen in the flue gas of power plants and from other sources has led to widespread chemical processing of flue gases. Figure 4.28 shows a schematic diagram of the gas flow path for removal of NO_x and SO_x after particulate removal in the precipitator and passage through an induced-draft fan. In this scheme, gas-to-gas heat exchangers (GGH) provide the proper temperatures for the flue gas desulfurization (FGD) unit and the DENOX catalyst unit. This additional equipment increases the pressure drop through the system, sometimes necessitating an additional fan.

With high smokestacks, the stack effect also influences the gas path and must be taken into account. The *stack effect* is the upward movement of exhaust gas produced by the density difference between the hot gases inside the stack and the surrounding cooler atmospheric air. Because of hot gas buoyancy, a smaller pressure gradient along the stack length is required to expel the combustion gases from the stack. This effect is opposed by the usual viscous friction pressure losses. The diameter and height of the stack control the relative influence of frictional forces in opposing the stack effect. Other considerations, such as cost and a possible need to disperse the stack gas above a particular height, also have a significant influence on these dimensions.

It is obvious that the air heater of the steam generator should extract as much energy from the combustion gas as possible to maximize its regenerative heat transfer effect. This implies cooling the gas to a low temperature. However, practical limits exist on the minimum combustion gas temperature, to avoid the condensation of water vapor in the presence of sulfur and nitrogen compounds in the gas and to meet the temperature requirements of the pollution control equipment. Condensation of water vapor in the presence of gaseous oxides of sulfur and nitrogen leads to the formation of acids that erode the materials on which the liquid condenses. The temperature at which the vapor condenses is called the *acid dew point*. Typical acid dew points for coal range to about 320°F. As a result, stack gas design temperatures may exceed that value, depending on the coal and flue gas treatment.

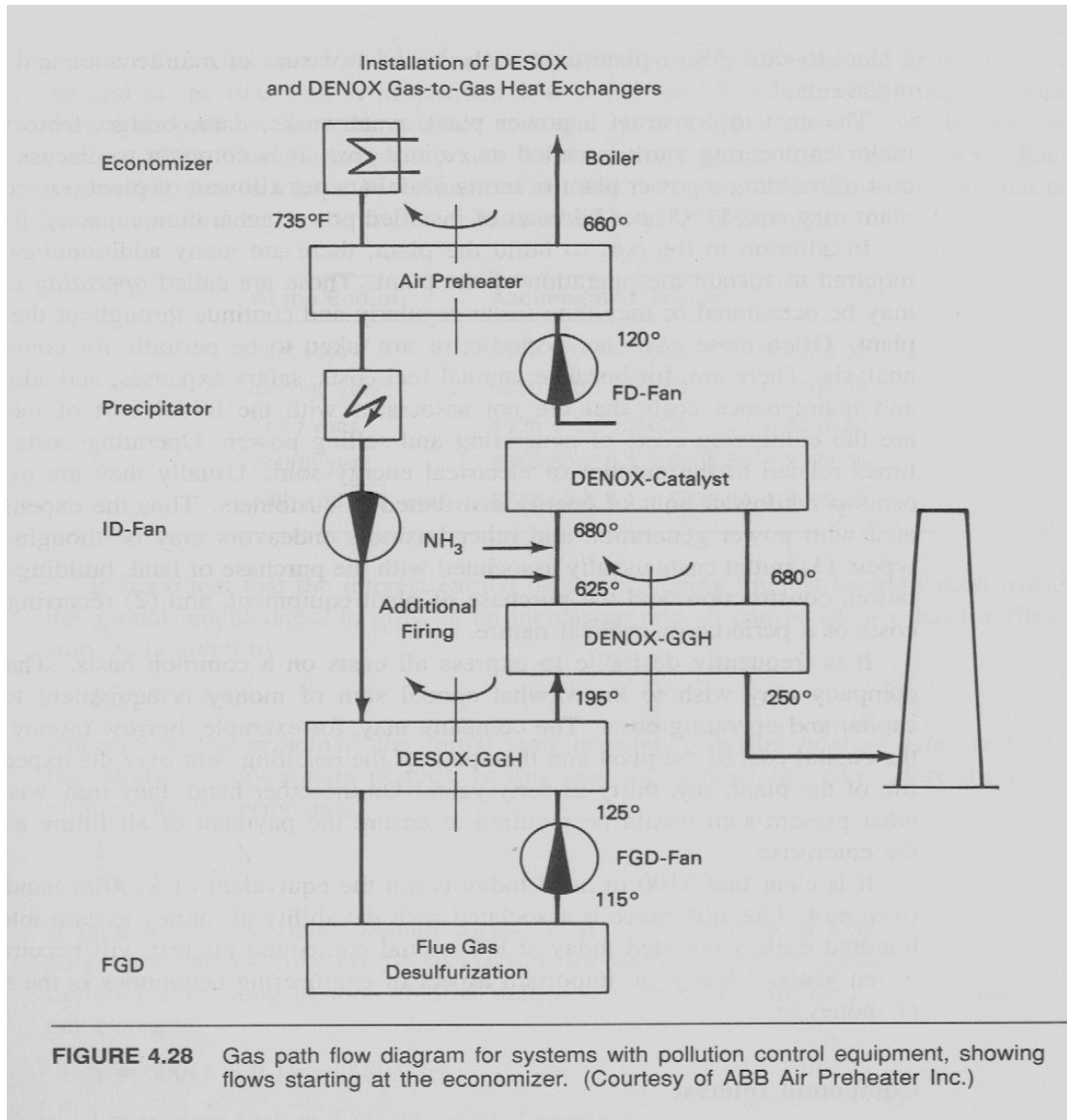

4.5 Introduction to Engineering Economics

The success of any engineering undertaking depends on adequate financial planning to ensure that the proceeds of the activity will exceed the costs. The construction of a new power plant or the upgrading of an old one involves a major financial investment for any energy company. Financial planning therefore starts long before ground is broken, detailed design is begun, and orders are placed for equipment. Cost analysis and fiscal control activities continue throughout the construction project and the operating life of the plant. This section briefly introduces fundamentals of engineering economics, with a slant toward power plant cost analysis as well as issues of maintenance and equipment replacement.

The cost to construct a power plant, waterworks, dam, bridge, factory, or other major engineering work is called its *capital cost*. It is common to discuss the capital cost of building a power plant in terms of dollars per kilowatt of plant power output. A plant may cost \$1100 per kilowatt of installed power generation capacity, for instance.

In addition to the cost of building the plant, there are many additional expenditures required to sustain its operation. These are called *operating costs*. They may be occasional, or they may occur regularly and continue throughout the life of the plant. Often these costs are periodic, or are taken to be periodic for convenience of analysis. There are, for instance, annual fuel costs, salary expenses, and administrative and maintenance costs that are not associated with the initial cost of the plant but are the continuing costs of generating and selling power. Operating costs are sometimes related to the amount of electrical energy sold. Usually they are expressed in cents per kilowatt-hour of energy distributed to customers.

Thus the expenses associated with power generation and other business endeavors may be thought of as two types: (1) initial costs usually associated with the purchase of land, building site preparation, construction, and the purchase of plant equipment; and (2) recurring operating costs of a periodic or cyclic nature.

It is frequently desirable to express all costs on a common basis. The company and its investors may wish to know what annual sum of money is equivalent to both the capital and operating costs. The company may, for example, borrow money to finance the capital cost of the plant and then pay the resulting debt over the expected useful life of the plant, say, 30 or 40 years. On the other hand, they may wish to know what present sum would be required to ensure the payment of all future expenses of the enterprise.

It is clear that \$100 in hand today is not the same as \$100 in hand ten years from now. One difference is that money can earn interest. One hundred dollars invested today at 8% annual compound interest will become \$215.89 in ten years. Clearly, an important aspect of engineering economics is the time value of money.

Compound Interest

If Alice lends Betty \$500, who agrees to pay \$50 each year for five years for the use of the money, together with the original \$500, then at the end of the fifth year, Alice will have earned \$250 in *simple interest* and receive a total of \$750 in return. The annual interest rate is

$$i = \text{Annual interest} / \text{Capital} = 50 / 500 = 0.1$$

or $(0.1)(100) = 10\%$ rate of return.

If, however, Betty keeps the interest instead of paying it to Alice annually, and eventually pays 10% on both the retained interest and the capital, the deal involves *compound interest*. The total sum to be returned to Alice after 5 years is computed as follows: At the end of the first year Alice has earned \$50 in interest. The interest for the

next year should be paid on the original sum and on the \$50 interest earned in the first year, or \$550. The interest on this sum for the second year is $0.1 \times \$550 = \55 . The following table shows the calculation of the annual debt for the five-year loan of \$500 at 10% interest:

of:	At the End	The Accumulated Debt is:	This Sum
	First year	$\$500 + 0.1 \times \$500 =$	\$550.00
	Second year	$\$550 + 0.1 \times \$550 =$	\$605.00
	Third year	$\$605 + 0.1 \times \$605 =$	\$665.50
	Fourth year	$\$665.50 + 0.1 \times \$665.50 =$	\$732.05
	Fifth year	$\$732.05 + 0.1 \times \$732.05 =$	\$805.26

It is evident that the interest earned on the preceding interest accumulation causes the annual indebtedness to grow at an increasing rate. It can be shown that the future sum, S , is given by

$$S = P(1 + i)^n$$

where P is the *principal*, the initial sum invested; i is the *interest rate*, and n is the number of investment periods, in this case the number of years. Here the factor multiplying the principal,

$$S/P = (1 + i)^n$$

is called the *compound amount factor*, CAF. The difference between simple and compound interest may not be spectacular for short investment periods but it is very impressive for long periods of time such as the operating life of a power plant. For our example, the CAF is $(1 + 0.1)^5 = 1.6105$, and $S = 500(1.6105) = \$805.26$. Now, consider the following closely related problem.

EXAMPLE 4.2

What sum is required now, at 8% interest compounded annually, to produce one million dollars in 25 years?

Solution

The *future sum* is

$$S = P(1 + i)^n = 1,000,000 = P(1 + 0.08)^{25}$$

Solving for P , the *present sum* is $1,000,000/(1.08)^{25} = \$146,017.90$. Thus, compound interest brings a return of almost over seven times the original investment here. The

same present sum invested at 8% *simple interest* for twenty-five years would produce a future sum of less than half a million dollars.

In the example, the inverse of the CAF was used to determine the *present worth* of a future sum. The inverse of the CAF is called the *present-worth factor*, (PWF):

$$PWF = P/S = 1 / (1 + I)^n$$

Thus we see that the time value of money is related to the compound interest that can be earned, and that taking compounding into account can be important. To recklessly adapt an old adage, “A dollar in the hand is worth two (or more) in the future (if invested wisely).”

Capital Recovery

Another important aspect of compound interest is the relationship between a present sum of money and a regular series of uniform payments. Consider a series of five annual payments of R dollars each, when the interest rate is i . What is the present dollar equivalent of these payments? Applying the CAF as in the preceding example, with R as the future sum, the present sum associated with the first payment is $R/(1 + i)$. The present sum associated with the second payment is $R/(1 + i)^2$. Thus the present worth of the five payments is

$$P = R [(1 + i)^{-1} + (1 + i)^{-2} + (1 + i)^{-3} + (1 + i)^{-4} + (1 + i)^{-5}]$$

It may be shown that this expression can be written as

$$P = R [(1 + i)^5 - 1] / [i(1 + i)^5].$$

The factor multiplying the annual sum R is called the *series present-worth factor*, SPWF, which for n years is:

$$SPWF = P/R = [(1 + i)^n - 1] / [i(1 + i)^n] \quad (4.1)$$

Solving for R , we obtain an expression for the regular annual payment for n years needed to fund a present expenditure of P dollars at an interest rate i . The resulting factor is called the *capital recovery factor*, CRF, which is the reciprocal of the series present worth factor:

$$CRF = R/P = i(1 + i)^n / [(1 + i)^n - 1] \quad (4.2)$$

EXAMPLE 4.3

What uniform annual payments are required for forty years at 12% interest to retire the debt associated with the purchase of a \$500,000,000 power plant?

Solution

Using equation (4.2), we get

$$R = Pi(1+i)/[(1+i)^n - 1] = 5 \times 10^8 (0.12)(1+0.12)^{40}/(1.12^{40} - 1) \\ = \$60,651,813$$

This sum may be regarded as part of the annual operating expense of the plant. It must be recovered annually by the returns from the sale of power.

4.6 A Preliminary Design Analysis of a 500-MW Plant

Consider the design of a 500-megawatt steam power plant with a heat rate of 10,000 Btu/kW-hr and a water-cooled condenser with a 20°F cooling-water temperature rise produced by heat transfer from the condensing steam. The plant uses coal with a heating value of 10,000 Btu/lb_m. Let us estimate the magnitude of some of the parameters that characterize the design of the plant. The reader should verify carefully each of the following calculations.

A 500-megawatt plant operating at full load produces 500,000 kW and an annual electrical energy generation of

$$500,000 \cdot 365 \cdot 24 = 4.38 \times 10^9 \text{ kW-hr}$$

With a heat rate of 10,000 Btu/kW-hr, this requires a heat addition rate of

$$500,000 \cdot 10,000 = 5 \times 10^9 \text{ Btu/hr}$$

Coal with an assumed heating value of 10,000 Btu/lb_m must therefore be supplied at a rate of $5 \times 10^9 / 10^4 = 500,000 \text{ lb}_m/\text{hr}$ or $500,000 / 2000 = 250 \text{ tons/hr}$. A dedicated coal car carries about 100 tons. Hence the plant requires $250 / 100 = 2.5$ cars per hour of continuous operation. A coal unit train typically has about 100 cars. Then the plant needs $2.5 \cdot 24 / 100 = 0.6$ unit trains per day, or a unit train roughly every two days.

If coal costs \$30 per ton, the annual cost of fuel will be

$$30 \cdot 250 \cdot 24 \cdot 365 = \$65,700,000$$

The cost of fuel alone per kW-hr, based on 100% annual plant capacity, will be

$$65,700,000 / (500,000 \cdot 365 \cdot 24) = \$0.015/\text{kW-hr} \Rightarrow 1.5 \text{ cents/kW-hr}$$

The *annual plant factor*, or *annual capacity factor*, expressed as a decimal fraction, is the ratio of the actual annual generation to the annual generation at 100 % capacity.

If the coal has 10% ash, the plant will produce $250 \cdot 0.1 = 25$ tons of ash per hour. Under some circumstances the ash may be used in the production of cement or other paving materials. If it is not marketable, it is stabilized and stored in nearby ash ponds until it can be moved to a permanent disposal site.

Similarly, if 2% of the coal is sulfur and half of it is removed from the combustion products, 2.5 tons per hour is produced for disposal. If the sulfur is of sufficient purity, it may be sold as an industrial chemical.

With an air-fuel ratio of 14, an air flow rate of $14 \cdot 500,000 = 7,000,000$ lb_m/hr is required for combustion. This information is important in determining the size of the induced- and forced-draft fans, that of their driving motors or turbines, and of the plant's gas path flow passages.

The heat rate of 10,000 Btu/kW-hr corresponds to a thermal efficiency of $3413/10,000 = 0.3413$ or 34.13%. If we approximate the heat of vaporization of water as 1000 Btu/lb_m, the throttle steam flow rate, with no superheat, would be about

$$10,000 \cdot 500,000 / 1000 = 5,000,000 \text{ lb}_m/\text{hr}$$

This determines the required capacity of the feedwater pumps and is important in sizing the passages for the water path. The above thermal efficiency implies that about 65% of the energy of the fuel is rejected into the environment, mostly through the condenser and the exiting stack-gas energy. As an upper limit, assume that all of the heat is rejected in the condenser. Thus

$$(1 - 0.3413)(5 \times 10^9) = 3.29 \times 10^9 \text{ Btu/hr}$$

must be rejected to condenser cooling water. With 20° water temperature rise in the condenser, this rate of cooling requires a cooling-water flow rate to the condenser of

$$3.29 \times 10^9 / (1.0 \times 20) = 1.65 \times 10^8 \text{ lb}_m / \text{hr}$$

assuming a water heat capacity of 1.0 Btu/lb_m-R. This gives information relevant to the design sizing of cooling-water lines, cooling towers, and water pump capacities.

These back-of-the-envelope calculations should not be regarded as precise, but they are reasonable estimates of the magnitudes of important power plant parameters. Such estimates are useful in establishing a conceptual framework of the relationships among design factors and of the magnitude of the design problem.

EXAMPLE 4.4

Relating to the above rough design of a 500-MW plant, and assuming the capital cost information of Example 4.3, determine the capital cost per kW of generation capacity and estimate the minimum cost of generation for the plant if it is predicted to have an

annual plant factor of 80% and maintenance and administrative costs of \$0.007 /kW-hr.

Solution

The unit cost of the power plant is

$$\$500,000,000/(500 \cdot 1000) = \$1000 \text{ per kW-hr}$$

of capacity. The capital cost part of the annual cost of power generation is

$$(60,651,813 \cdot 100)/(365 \cdot 24 \cdot 0.8 \cdot 500,000) = 1.73 \text{ cents per kW-hr}$$

The cost of coal was determined to be 1.5 cents/kW-hr. The minimum cost of producing electricity is then

$$1.73 + 1.5 + 0.7 = 3.93 \text{ cents per kW-hr}$$

Bibliography and References

1. Singer, Joseph G., (Ed.), *Combustion /Fossil Power Systems*. Windsor, Conn.: Combustion Engineering, Inc., 1981.
2. Anon., *Steam, It's Generation and Use*. New York: Babcock and Wilcox, 1978.
3. Hensley, John C., *Cooling Tower Fundamentals*. Mission, Kan.: Marley Cooling Tower Co., 1985.
4. Li, Kam W., and Priddy, A. Paul, *Power Plant Systems Design*. New York: Wiley, 1985.

EXERCISES

- 4.1 Derive an equation for the sum, S , resulting from P dollars invested at simple interest rate i for a period of n years.
- 4.2 For the power plant design discussed in Section 4.6, estimate the horsepower of a motor required to drive the fans used to overcome a steam generator gas-path pressure drop of 1 psia. Assume a fan efficiency of 80%. What is the fractional and percentage reduction in power plant output due to the fans?
- 4.3 Estimate the horsepower required by the feedwater pumps in the Section 4.6 design if the HP-turbine throttle pressure is 3200 psia. Assume a pump efficiency of 70%. What fractional and percentage reduction of the power plant output does this represent?

4.4 What are the annual savings in fuel costs in the Section 4.6 plant design if the plant heat rate can be reduced to 8500 Btu/kW-hr?

4.5 If the total capital cost of the Section 4.6 plant design is \$600,000,000 and the annual administrative and maintenance costs are one cent per kW-hr, what is the minimum cost of electricity per kW-hr, assuming an annual interest rate of 9% and an expected plant lifetime of thirty-five years?

4.6 What is the present worth of a sequence of five annual payments of \$4500, \$6500, \$3500, \$7000, and \$10,000 at an annual interest rate of 8%?

4.7 You have collected the following data on 1.5-MW steam turbines, as alternatives to the purchase of utility power, for a new process plant to operate at 60% plant factor:

	Turbine Number		
	1	2	3
Heat rate, Btu/kW-hr	12,000	10,600	9,500
Installed cost	\$124,000	\$190,000	\$245,000
Estimated annual maintenance cost	\$2,000	\$1,800	\$2,550

Coal (14,000 Btu/lb_m) is the fuel to be used, at a cost of \$26 per ton. Assuming an annual interest rate of 8%, compare the annual cost of the turbines for thirty-year turbine lifetimes. Which turbine would you select? What other factors would you consider before making a decision?

4.8 Using the data of Exercise 4.7, compare the turbines on the basis of present worth of all costs.

4.9 For the power plant design discussed in Section 4.6, estimate the motor horsepower required to drive a 75% efficient fan that is used to overcome a steam generator gas-path pressure drop of 50 kPa.

4.10 Estimate the total power required by 65% efficient feedwater pumps operating in parallel in the Section 4.6 design for a throttle pressure of 20 MPa.

4.11 Work out a back-of-the-envelope analysis similar to that of Section 4.6 in SI units.

4.12* Develop an interactive computer program that implements a steam power plant system analysis of the type presented in Section 4.6 at one of the following levels, to be

assigned by your instructor.

Level 1: User supplies parameters in response to screen prompts, and one or more output screens display the resulting input and output parameters.

Level 2: Same as *Level 1*, but also provide a capability for the user to change the design by varying one input while holding all others constant.

Level 3: Allow the user to select a dependent variable from a list of outputs, and a parameter to be varied and its range from another list. Display a graph of the variation of user-selected outputs over the range of the parameter.

4.13* Construct a spreadsheet that systematizes the computations for a steam power plant along the lines presented in this chapter. Set up a version of the spreadsheet that allows easy variation of input parameters. Use the spreadsheet to develop graphs that show the influence of plant heat rate on fuel costs and sulfur byproduct production.

4.14 An electric utility, expecting to increase its system capacity by 400 megawatts, must choose between a high-technology combined-cycle plant, at a cost of \$1800 per kW of installed capacity, and an oil-burning steam plant, at \$1150 per kW. The combined-cycle plant has a variable cost of 18 mills per kW-hr, while the oil-burning plant variable cost is 39 mills per kW-hr. For an annual plant factor of 0.6 and fixed charges of 15% of the capital cost, determine (a) the total annual cost of operation of each plant, and (b) the cost of electricity, in cents per kW-hr, for each plant.

4.15 Estimate the mass-flow rate of makeup water required by an evaporative cooling tower satisfying the cooling requirements of the example power plant of Section 4.6.

4.16 An 800-MW steam power plant operates at a heat rate of 8700 Btu/kW-hr. It has a 16°F rise in condenser cooling-water temperature. Neglecting energy losses, estimate the condenser cooling-water flow rate and the flow-rate of cooling-tower makeup water. Estimate the amount of pump power required to circulate the cooling water to the cooling tower.

4.17 Plot a curve of condenser cooling-water flow rate and makeup-water flow rate as a function of condenser cooling-water temperature rise for Riverside Station Unit #1.

4.18 The average temperature in an 800 ft. high power plant exhaust gas stack is 350°F and the ambient temperature is 60°F. Neglecting fluid friction and exhaust gas kinetic energy, estimate the pressure inside the base of the stack.

4.19 The average temperature in a 200 meter power plant exhaust gas stack is 150°C, and the ambient temperature is 20°C. Neglecting fluid friction and exhaust gas momentum, estimate the pressure, in kPa, at the inside of the base of the stack.

4.20 Estimate the heat transfer rates in the Riverside Station Unit #1 in the air pre-heater, an economizer that heats liquid water to saturation, the boiling surfaces, the re-heater, and the superheater. Estimate the temperature drops in the combustion gas across each of these, assuming that they are arranged in the same order as just listed.

4.21 After completing Exercise 4.20, estimate the flow area of combustion gas through a crossflow economizer in the Riverside Station Unit #1, and define a suitable design.

4.22 After completing Exercise 4.20, estimate the flow area of combustion gas through a pendant superheater consisting of parallel U-tubes in cross flow, and define a suitable design.

4.23 The following is a list of ten *air and gas path* components of a steam power plant. Number the components so as to put them in order, starting with the air into the plant as number 1 and concluding with the flue gas out as number 10.

_____	superheater	_____	boiler tubewall
_____	economizer	_____	windbox
_____	induced-draft fan	_____	air heater, gas side
_____	burner	_____	electrostatic precipitator
_____	forced-draft fan	_____	air heater, air side

4.24 Upon hiring on with Hot Stuff Engineering Company after graduation, you purchase a \$30,000 automobile to establish an image as a prosperous engineer. You pay no money down, but 1% interest per month, compounded monthly, for four years. What are your monthly payments? What will your payments be if you are paying simple interest?

4.25 A forced-draft fan with an efficiency of 70% supplies 1,000,000 ft³ per minute of air to a furnace that produces a pressure drop of 0.7 psia. What is the fan power requirement, in horsepower and in kilowatts?