

CHAPTER 7

THE WANKEL ROTARY ENGINE

7.1 A Different Approach to the Spark-Ignition Engine

The reciprocating internal combustion engine has served mankind for over a century, and will continue to do so for the foreseeable future. The *Wankel rotary engine*, a much more recent development, is said to have been conceived in its present form in 1954 (ref. 2). An implementation of the rotary engine used in the 1990 Mazda RX-7 automobile and its turbocharger are shown in Figures 7.1(a) and 7.1(b). As of 1987, over 1.5 million Wankel engines had been used in Mazda automobiles (ref. 6).

The rotary engine has a host of advantages that make it a formidable contender for some of the tasks currently performed by reciprocating engines. The piston in a four-stroke-cycle reciprocating engine must momentarily come to rest four times per cycle as its direction of motion changes. In contrast, the moving parts in a rotary engine are in continuous unidirectional motion. Higher operating speeds, ease of balancing, and absence of vibration are a few of the benefits. The high operating speeds allow the engine to produce twice as much power as a reciprocating engine of the same weight. It has significantly fewer parts and occupies less volume than a reciprocating engine of comparable power.

With all these advantages, why are there so few Wankel engines in service? Part of the answer lies in the reciprocating engine's remarkable success in so many applications and its continuing improvement with research. Why change a good thing? Manufacturing techniques for reciprocating engines are well known and established, whereas production of rotary engines requires significantly different tooling.

It must be admitted, however, that the rotary engine has some drawbacks. A major problem of the Wankel automobile engine is that it does not quite measure up to the fuel economy of some automotive reciprocating SI engines. It is the judgment of some authorities that it does not offer as great a potential for improvement in fuel economy and emissions reduction as reciprocating and gas turbine engines. However, although the rotary engine may never dominate the automotive industry, it is likely to find applications where low weight and volume are critical, such as in sports cars, general aviation, and motorcycles.

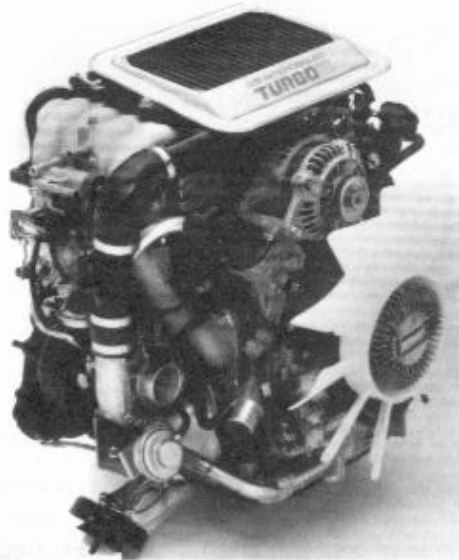

FIGURE 7.1a A turbocharged RX-7 rotary engine. (Photo courtesy of Mazda Motors of America.)

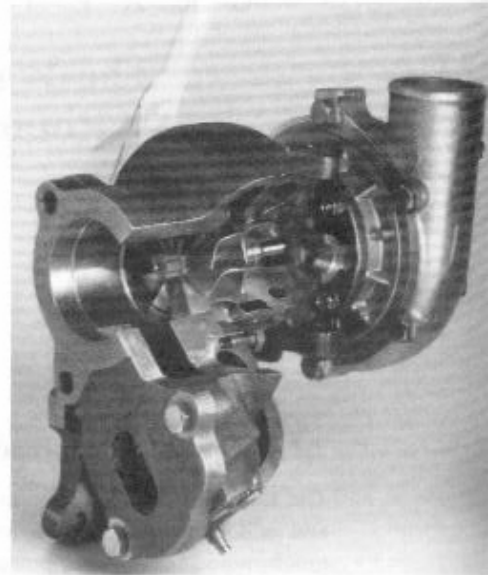

FIGURE 7.1b An RX-7 rotary engine turbocharger. (Photo courtesy of Mazda Motors of America.)

While the rotary engine may not enjoy the great success of reciprocating engines, it is worthy of study as an unusual and analytically interesting implementation of the familiar Otto cycle. Even the present success of this latter-day Otto engine should serve as an inspiration to those who search for novel ways of doing things. This chapter is a tribute to Felix Wankel and those who are helping to develop this remarkable engine.

7.2 Rotary Engine Operation

Figure 7.2 shows a cross-section of a rotary engine. The stationary housing encloses a moving triangular rotor that rotates with its apexes in constant contact with the housing inner surface. Air and combustion gases are transported in the spaces between the rotor and the housing. The rotor rides on an eccentric that is an integral part of a shaft, as shown in the dual rotor crank shaft of Figure 7.3(a). The housing and rotor of a rotary engine designed for aircraft application are shown in Figure 7.3(b).

The operation of the Wankel engine as an Otto-cycle engine may be understood by following in Figure 7.4 the events associated with the counterclockwise movement of a gas volume isolated between the housing and one of the rotor flanks. The air-fuel mixture may be supplied, by a conventional carburetor, through the intake port labeled I in Figure 7.4(a). As the shaft and rotor turn, the intake port is covered, trapping a fixed mass of air and fuel (assuming no leakage). This is analogous to the gas mass captured within the cylinder-piston volume by closure of a reciprocating engine intake valve. As the rotor continues to turn, the captured (crosshatched) volume contained

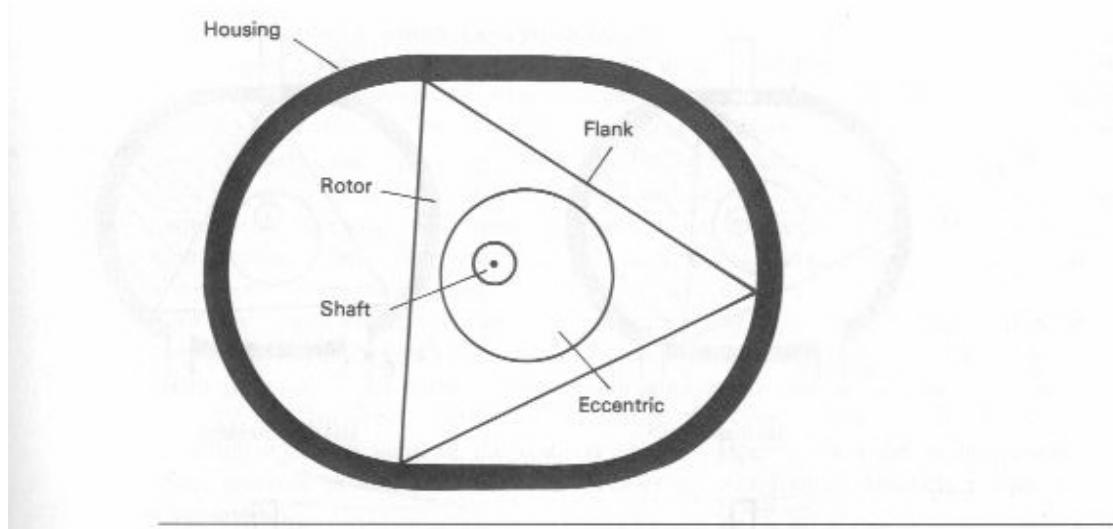

FIGURE 7.2 Rotary engine nomenclature.



FIGURE 7.3a John Deere model 2034R engine components: Crankshaft and one of two counterweights. (Courtesy of John Deere Technologies International Inc., Rotary Engine Div., Wood-Ridge, N.J.)

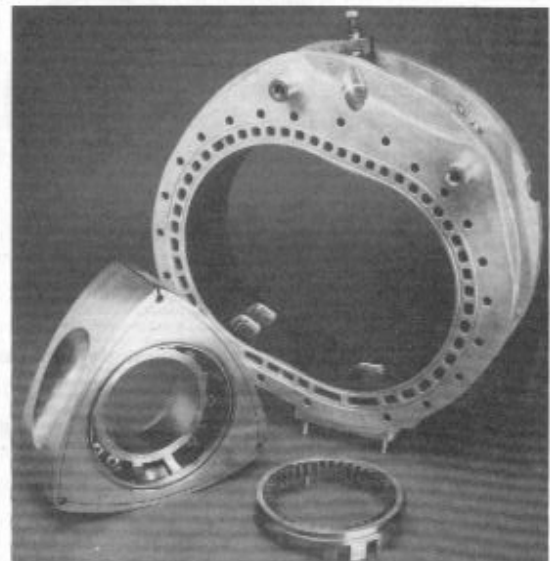

FIGURE 7.3b John Deere model 2034R engine components: Rotor housing, rotor, and rotor gear. (Courtesy of John Deere Technologies International Inc., Rotary Engine Div., Wood-Ridge, N.J.)

between the rotor and housing decreases, compressing the air-fuel mixture [part (b)]. When it reaches the minor diameter, the active mixture volume is a minimum corresponding to the volume at top center in the reciprocating engine. One or more spark plugs, as indicated at the top of each housing, initiate combustion, causing rapid rises in pressure and temperature [part (c)]. The hot, high-pressure combustion gas [part (d)] transmits a force to the eccentric through the rotor. Note that, during the

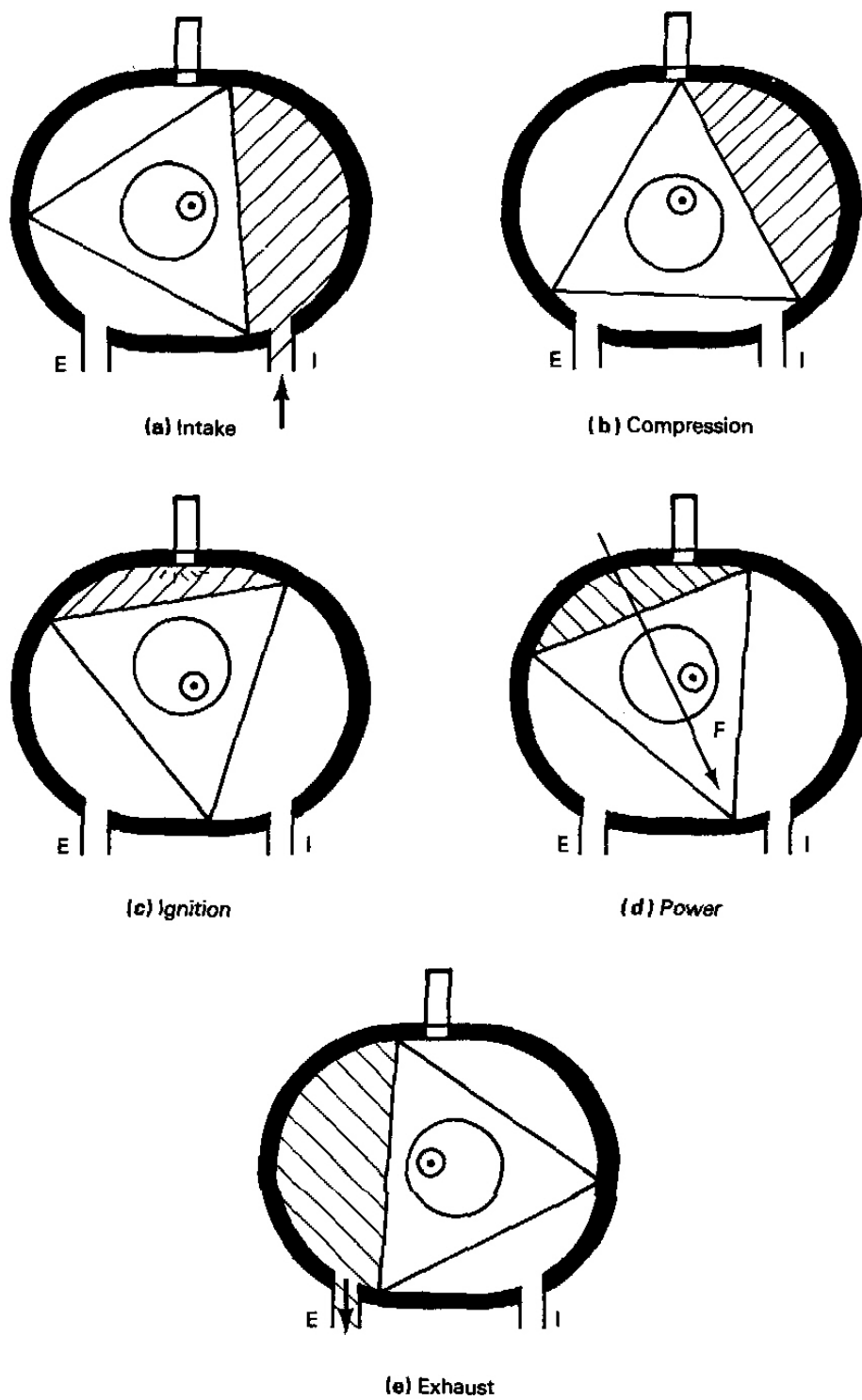

FIGURE 7.4 Successive phases in the execution of the Otto cycle in a rotary engine.

power phase, the line of action of the force F provides a counterclockwise torque acting about the shaft axis. As the rotation proceeds, the expanding gases drive the rotor until the exhaust port is exposed, releasing them [part (e)]. The exhaust process continues as the intake port opens to begin a new cycle. This port overlap is apparent in the lower volume shown in part (b). In summary, each flank of the rotor is seen to undergo the same intake, compression, ignition, power, and exhaust processes as in a four-stroke-cycle reciprocating Otto engine.

All three flanks of the rotor execute the same processes at equally spaced intervals during one rotor rotation. Hence three power pulses are delivered per rotation of the rotor. Because there are three shaft rotations per rotor rotation, the Wankel engine has one power pulse per shaft rotation. Thus it has twice as many power pulses as a single-cylinder four-stroke-cycle reciprocating engine operating at the same speed, a clear advantage in smoothness of operation. This feature of one power pulse per shaft rotation causes many people to compare the Wankel engine with the two-stroke-cycle reciprocating engine.

7.3 Rotary Engine Geometry

The major elements of the rotary engine—the housing and the rotor—are shown in cross-section in Figure 7.2. The housing inner surface has a mathematical form known as a *trochoid* or *epitrochoid*. A single-rotor engine housing may be thought of as two parallel planes separated by a cylinder of epitrochoidal cross-section. Following the notation of Figure 7.5, the parametric form of the epitrochoid is given by

$$x = e \cos 3\alpha + R \cos \alpha \quad [\text{ft} \mid \text{m}] \quad (7.1a)$$

$$y = e \sin 3\alpha + R \sin \alpha \quad [\text{ft} \mid \text{m}] \quad (7.1b)$$

where e is the *eccentricity* and R is the rotor center-to-tip distance. For given values of e and R , Equations (7.1) give the x and y coordinates defining the housing shape when α is varied from 0 to 360 degrees.

The rotor shape may be thought of as an equilateral triangle, as shown in Figures 7.2 and 7.4 (flank rounding and other refinements are discussed later in the chapter). Because the rotor moves inside the housing in such a way that its three apexes are in constant contact with the housing periphery, the positions of the tips are also given by equations of the form of Equations (7.1):

$$x = e \cos 3\alpha + R \cos(\alpha + 2n\pi/3) \quad [\text{ft} \mid \text{m}] \quad (7.2a)$$

$$y = e \sin 3\alpha + R \sin(\alpha + 2n\pi) \quad [\text{ft} \mid \text{m}] \quad (7.2b)$$

where $n = 0, 1, \text{ or } 2$, the three values identifying the positions of the three rotor tips, each separated by 120° . Because R represents the rotor center-to-tip distance, the

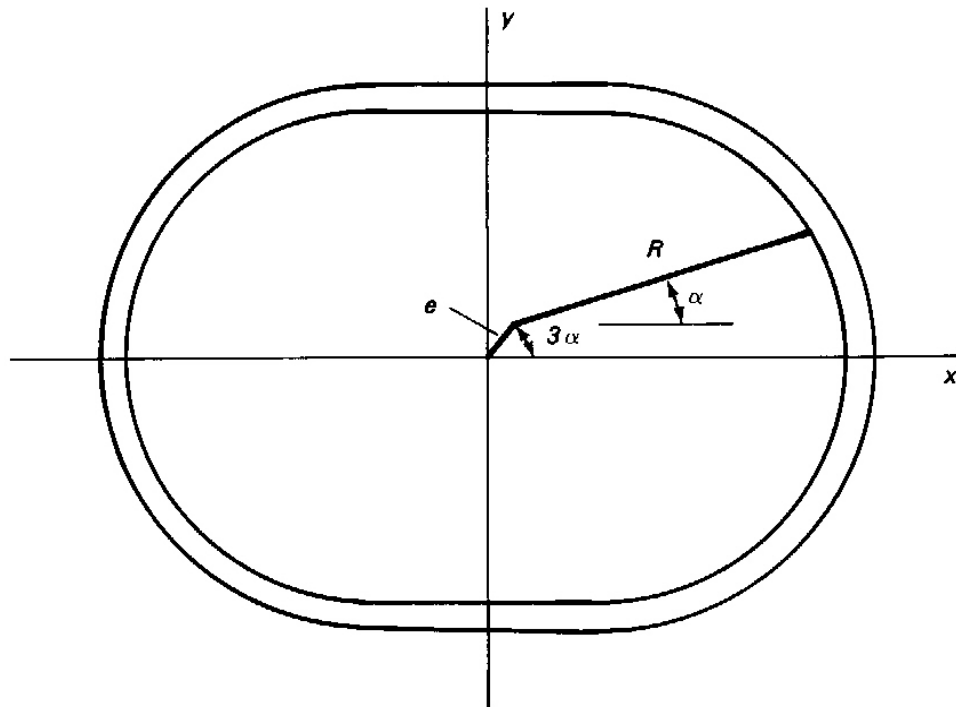

FIGURE 7.5 Nomenclature for epitrochoid parametric equations.

motion of the center of the rotor can be obtained from Equations (7.2) by setting $R = 0$. The equations and Figure 7.5 indicate that the path of the rotor center is a circle of radius e .

Note that Equations (7.1) and (7.2) can be nondimensionalized by dividing through by R . This yields a single geometric parameter governing the equations, e/R , known as the *eccentricity ratio*. It will be seen that this parameter is critical to successful performance of the rotary engine.

The power from the engine is delivered to an external load by a cylindrical shaft. The shaft axis coincides with the axis of the housing, as seen in Figure 7.2. A second circular cylinder, the *eccentric*, is rigidly attached to the shaft and is offset from the shaft axis by a distance, e , the eccentricity. The rotor slides on the eccentric. Note that the axes of the rotor and the eccentric coincide. Gas forces exerted on the rotor are transmitted to the eccentric to provide the driving torque to the engine shaft and to the external load.

The motion of the rotor may now be understood in terms of the notation of Figure 7.5. The line labeled e rotates with the shaft and eccentric through an angle 3α , while the line labeled R is fixed to the rotor and turns with it through an angle α about the moving eccentric center. Thus the entire engine motion is related to the motion of these two lines. Clearly, the rotor (and thus line R) rotates at one-third of the speed of the shaft, and there are three shaft rotations for each rotor revolution.

EXAMPLE 7.1

Derive expressions for the major (largest) and minor (smallest) diameters of an epitrochoid in terms the notation of Figure 7.5.

Solution

The major diameter is defined by adding the lengths of the lines representing the eccentricity and the rotor radius when they are horizontal and colinear or by using Equation 7.1(a). Thus the major diameter at $y = 0$ corresponds to $\alpha = 0^\circ$ and 180° , for which $x = e + R$ and $x = -e - R$, respectively. The distance between these x coordinates is the length of the major diameter $2(e + R)$.

The minor diameter is similarly defined along $x = 0$, but with e and R lines oppositely directed. The two cases correspond to $\alpha = 90^\circ$ and 270° . For $\alpha = 90^\circ$, the e line is directed downward and the R line upward in Figure 7.5. This yields $y = R - e$ and, by symmetry, the minor diameter is $2(R - e)$. Hence

$$\text{Major diameter} = 2(R + e)$$

$$\text{Minor diameter} = 2(R - e)$$

7.4 A Simple Model for a Rotary Engine

Additional important features of the rotary engine can be easily studied by considering an engine with an equilateral triangular rotor. Figure 7.6 shows the rotor in the position where a rotor flank defines the minimum volume. We will call this position top center, TC, by analogy to the reciprocating engine. The rotor housing *clearance parameter*, d , is the difference between the housing minor radius, $R - e$, and the distance from the housing axis to mid-flank, $e + R \cos 60 = e + R/2$:

$$d = (R - e) - (e + R/2) = R/2 - 2e \quad [\text{ft} \mid \text{m}] \quad (7.3)$$

Setting the clearance to zero establishes an upper limiting value for the eccentricity ratio: $(e/R)_{\text{crit}} = 1/4$. Study of Equations (7.1), at the other extreme, shows that, for $e/R = 0$, the epitrochoid degenerates to a circle. In this case the rotor would spin with no eccentricity and thus produce no compression and no torque. Thus, for the flat-flanked rotor, it is clear that usable values of e/R lie between 0 and 0.25.

Now let's examine some other fundamental parameters of the flat-flanked engine model. Consider the maximum mixture volume shown in Figure 7.7. For a given rotor width w , the maximum volume can be determined by calculating the area between the housing and the flank of the rotor. Using Equations (7.1), the differential area $2y \, dx$ can be written as:

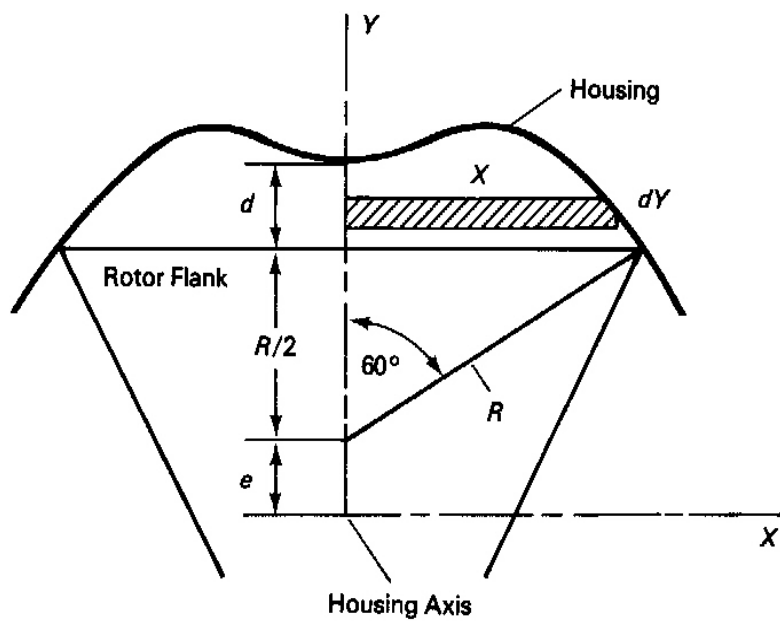

FIGURE 7.6 Minimum working-fluid volume for a flat-flanked rotary engine.

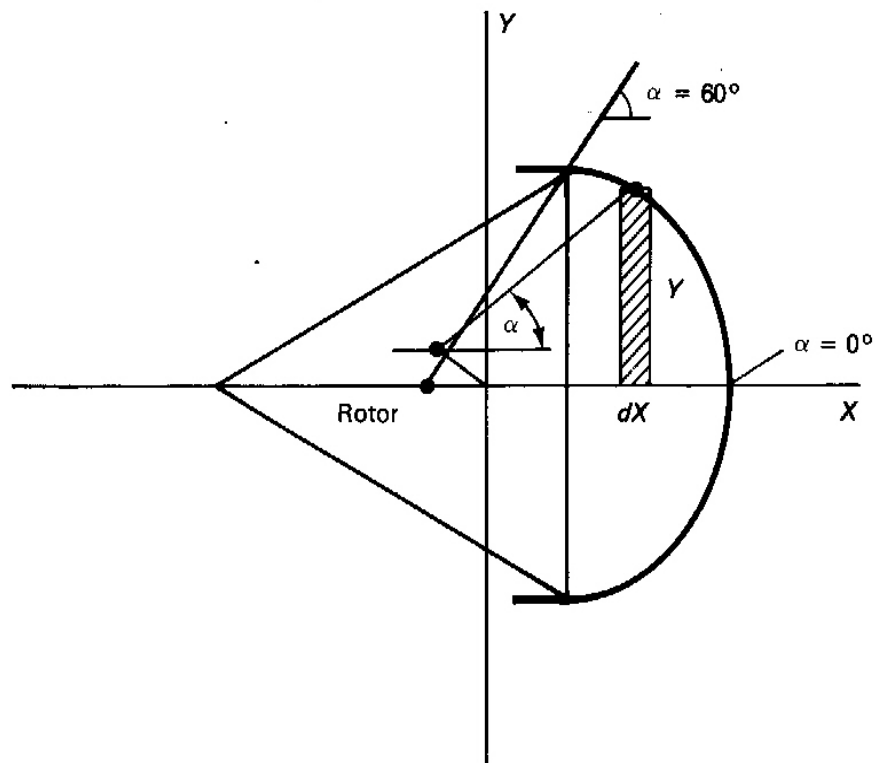

FIGURE 7.7 Maximum working-fluid volume for a flat-flanked rotary engine.

$$\begin{aligned}
 dA_{max} &= 2y \, dx \\
 &= 2(e \sin 3\alpha + R \sin \alpha) d(e \cos 3\alpha + R \cos \alpha) \quad [\text{ft}^2 | \text{m}^2] \quad (7.4)
 \end{aligned}$$

Dividing by R^2 and differentiating on the right-hand side, we obtain an equation for the dimensionless area in terms of the eccentricity ratio and the angle α :

$$A_{max}/R^2 = -2 \int_0^{60} [(e/R)\sin 3\alpha + \sin \alpha][3(e/R)\sin 3\alpha + \sin \alpha] d\alpha \quad [\text{dl}] \quad (7.5)$$

In order for the differential area to sweep over the maximum trapped volume in Figure 7.7, the limits on the angle α must vary from 0° to 60° . Thus integration of Equation (7.5) with these limits and using standard integrals yields

$$A_{max}/R^2 = \pi [(e/R)^2 + 1/3] - 3^{1/2}/4 [1 - 6(e/R)] \quad [\text{dl}] \quad (7.6)$$

Similarly, using Figure 7.6 and the differential volume shown there, the nondimensionalized minimum area can be written as:

$$A_{min}/R^2 = \pi [(e/R)^2 + 1/3] - 3^{1/2}/4 [1 + 6(e/R)] \quad [\text{dl}] \quad (7.7)$$

These maximum and minimum volumes (area-rotor width products) are analogous to the volumes trapped between the piston and cylinder at BC and TC in the four-stroke reciprocating engine. In that engine the difference between the volumes at BC and TC is the displacement volume, and their ratio is the compression ratio. A little thought should convince the reader that the analogy holds quantitatively for the displacement and compression ratio of the rotary engine. Therefore, subtracting Equation (7.7) from Equation (7.6) gives the displacement for a rotor width w for one flank of the flat-flanked engine as

$$\text{disp} = 3 \cdot 3^{1/2} w R^2 (e/R) \quad [\text{ft}^3 | \text{m}^3] \quad (7.8)$$

and forming their ratio yields the compression ratio as

$$\text{CR} = \frac{A_{max}/R^2}{A_{min}/R^2} = \frac{\pi [(e/R)^2 + 1/3] - 3^{1/2}/4 [1 - 6(e/R)]}{\pi [(e/R)^2 + 1/3] - 3^{1/2}/4 [1 + 6(e/R)]} \quad [\text{dl}] \quad (7.9)$$

Thus the displacement increases with increases in rotor width, the square of the rotor radius, and with the eccentricity ratio, whereas the compression ratio is independent of size but increases with increase in eccentricity ratio.

EXAMPLE 7.2

What are the displacement and the compression ratio for a flat-flanked rotary engine with a rotor radius of 10 cm, an eccentricity of 1.5 cm, and a rotor width of 2.5 cm?

Solution

For this engine, $e/R = 1.5/10 = 0.15$. Equation (7.8) then yields the displacement:

$$3(3)^{0.5}(0.15)(10)^2(2.5) = 194.9 \text{ cm}^3 \quad \text{or} \quad (194.9)(0.0610) = 11.89 \text{ in.}^3$$

Equation (7.9) can be written as

$$\text{CR} = (a + b)/(a - b)$$

where $a = (3.14159)[(0.15)^2 + 1/3] - 3^{1/2}/4 = 0.6849$, and $b = 3 \cdot 3^{1/2}(0.15)/2 = 0.3897$. Then

$$\text{CR} = (0.6849 + 0.3897)/(0.6849 - 0.3897) = 3.64$$

The very low compression ratio of Example 7.2 would yield a poor Otto-cycle thermal efficiency. The compression ratio could be increased by increasing e/R , but it would still be low for most applications. It is therefore important to consider the favorable influence of flank rounding on rotary engine performance.

7.5 The Circular-Arc-Flank Model

While the triangular rotor model represents a possible engine and is useful as a learning tool, such an engine would perform poorly compared with one having a rotor with rounded flanks. A more realistic model is one in which the triangular rotor is augmented with circular-arc flanks, as shown in Figure 7.8. The radius of curvature, r , of a flank could vary from infinity, corresponding to a flat flank, to a value for which the arc touches the minor axis of the epitrochoid. Note that the center of curvature of an arc terminated by two flank apexes depends on the value of r . It can also be seen from Figure 7.8 that r is related to the angle, θ , subtended by the flank arc by

$$r \sin(\theta/2) = R \sin(\pi/3) = 3^{1/2}R/2 \quad [\text{ft} \mid \text{m}]$$

or

$$r/R = 3^{1/2}/[2\sin(\theta/2)] \quad [\text{dl}] \quad (7.10)$$

Thus either the included angle, θ , or the radius of curvature, r , may be used to define the degree of flank rounding for a given rotor radius R .

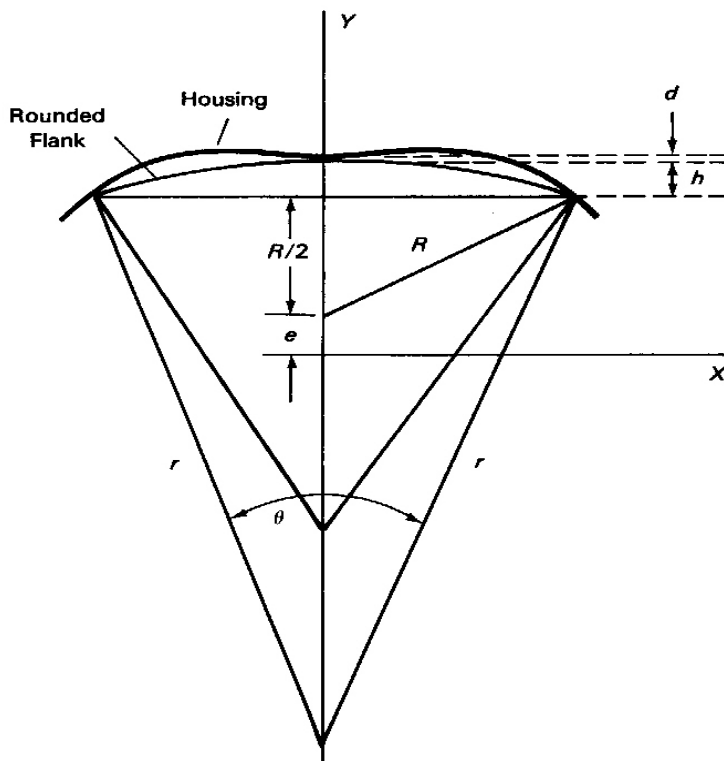

FIGURE 7.8 Geometry of the circular-arc rotor.

Clearance with Flank Rounding

The additional area obtained by capping a side of a triangle with a circular arc is called a segment. The segment height, h , shown in Figure 7.8, is the difference between r and the projection of r on the axis of symmetry:

$$h/R = (r/R)[1 - \cos(\theta/2)] \quad [\text{dl}] \quad (7.11)$$

Substitution of Equation (7.10) in Equation (7.11) yields

$$h/R = 3^{1/2} [1 - \cos(\theta/2)] / [2\sin(\theta/2)] \quad [\text{dl}] \quad (7.12)$$

It is evident from the figure that the clearance for the rotor with circular arc flanks is the difference between the clearance of the flat-flanked rotor and h . Thus, using Equation (7.3), the clearance is given by

$$d/R = 1/2 - 2(e/R) - 3^{1/2} [1 - \cos(\theta/2)] / [2\sin(\theta/2)] \quad [\text{dl}] \quad (7.13)$$

In a real engine, of course, the clearance must be non-negative.

Added Volume per Flank Due to Rounding

The segment area is the difference between the pie-shaped area of the sector subtended by its included angle, θ , and the enclosed triangular area. The sector area, or volume per unit rotor width, is the fraction of the area of a circle of radius, r , subtended by the angle θ , i.e., $\pi r^2 (\theta/2\pi) = r^2 \theta/2$. Thus using Equation (7.10), the dimensionless segment volume is

$$\begin{aligned} A_s/R^2 &= (A_{\text{sec}} - A_{\text{tri}})/R^2 = (r/R)^2(\theta - \sin \theta)/2 \\ &= (3/8)(\theta - \sin \theta)/\sin^2 \theta/2 \end{aligned} \quad [\text{dl}] \quad (7.14)$$

Displacement and Compression Ratio

It was pointed out earlier that the displacement of the flat-flanked engine is the difference between the maximum and minimum capture volumes, and is given by Equation (7.8). This is true also for the engine with rounded flanks. The additional volume added to the rotor by flank rounding subtracts from both of the flat-flanked maximum and minimum capture volumes, leaving the difference unchanged. Thus the displacement of one flank of a rounded-flank engine is

$$\text{disp} = 3 \cdot 3^{1/2} wR^2 (e/R) \quad [\text{ft}^3 | \text{m}^3] \quad (7.15)$$

Likewise, the ratio of the maximum and minimum capture volumes given by Equations (7.6) and (7.7), corrected for the segment volume from Equation (7.14) provides a relation for the rounded-flank engine compression ratio:

$$\text{CR} = \frac{\pi [(e/R)^2 + 1/3] - 3^{1/2}/4 [1 - 6(e/R)] - A_s/R^2}{\pi [(e/R)^2 + 1/3] - 3^{1/2}/4 [1 + 6(e/R)] - A_s/R^2} \quad [\text{dl}] \quad (7.16)$$

The added rotor volume due to rounding subtracts from the flat-flanked capture volumes and therefore reduces the denominator of Equation (7.16) more than the numerator. As a result, the compression ratio is greater for rounded-flank than for flat-flanked engines. Rotary engines usually have the maximum rounding possible consistent with adequate engineering clearances.

Effect of the Recess Volume

Equation (7.16) accounts for flank rounding but not for the recess usually found in rotor flanks. The additional capture volume associated with the recess is seen in Figure 7.9. Its influence on the displacement and compression ratio may be reasoned in the

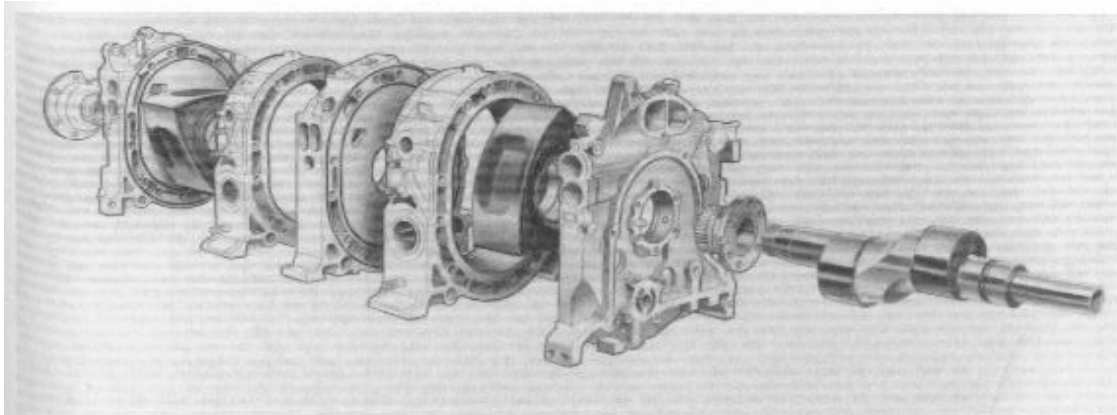

FIGURE 7.9 Exploded view of a twin-rotor rotary engine. (Courtesy of Mazda Motors of America.)

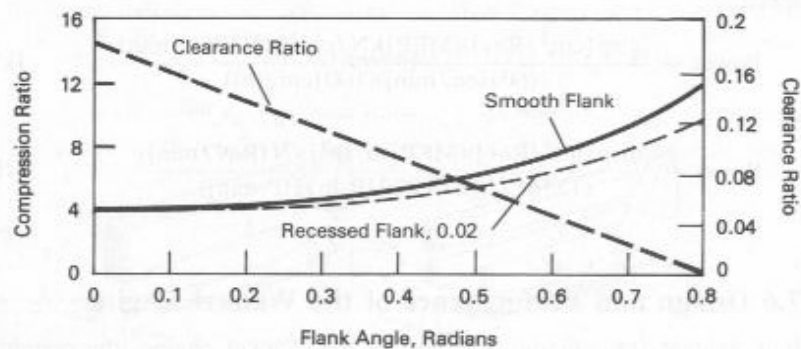

FIGURE 7.10 Influence of flank rounding on clearance and compression ratio for an eccentricity ratio of 0.16.

same way as with the segment volume. The recess increases both minimum and maximum mixture volumes by the same amount. It therefore has no effect on displacement and it decreases the compression ratio.

Figure 7.10 shows the influence of flank rounding and recession on clearance and compression ratio. While flank recession reduces the compression ratio for given values of θ and e/R , it improves the shape of the long, narrow combustion pocket forming the minimum capture volume. Rotary engines usually have more than one spark plug, to help overcome the combustion problems associated with this elongated shape.

EXAMPLE 7.3

Rework Example 7.2, taking into account a flank-arc included angle of 0.65 radians. What is the flank clearance for this engine?

Solution

Because flank rounding does not influence it, the displacement is still 194.9 cm^3 . Equation (7.16) rewritten using the notation of Example 7.2 becomes

$$CR = (a + b - A_s/R^2) / (a - b - A_s/R^2)$$

where $A_s/R^2 = (3/8)[0.65 - \sin(0.65)]/\sin^2(0.65/2) = 0.1648$. Then the compression ratio is

$$CR = [0.6849 + 0.3897 - 0.1648] / [0.6849 - 0.3897 - 0.1648] = 6.98$$

This represents a significant improvement over the value of 3.64 for the flat-flanked rotor.

The flank clearance is given by Equation (7.13):

$$d = 10\{0.5 - 2(0.15) - 3^{1/2}[1 - \cos(0.65/2)]\} / [2\sin(0.65/2)] = 0.58 \text{ cm.}$$

We have already noted that the displacement volume associated with one flank of the rotary engine produces one power stroke during each rotor revolution and during three shaft rotations. Because there are three flanks per rotor, a rotor executes one complete thermodynamic cycle per shaft rotation. Thus the power produced by a single rotor is determined by the displacement volume of a single flank and the rotational speed:

$$\text{Power} = \frac{(\text{disp [cm}^3/\text{Rev)}](\text{MEP [kN/cm}^2])(\text{N [Rev/min]})}{(60 [\text{sec/min}])(100 [\text{cm/m}])} \quad [\text{kW}]$$

or

$$\text{Power} = \frac{(\text{disp [in}^3/\text{Rev)}](\text{MEP [lb/in}^2])(\text{N [Rev/min]})}{(12 [\text{in/ft}])(33,000 [\text{ft-lb/HP-min}])} \quad [\text{HP}]$$

7.6 Design and Performance of the Wankel Engine

It is evident from Figure 7.4 that, in the Wankel engine, the opening and closing of the intake and exhaust ports by the motion of the rotor apexes serves a function equivalent to that of mechanical valves in reciprocating engines. This simple operation in the Wankel engine eliminates the need for many of the moving parts required by the reciprocating engine, such as cams, camshafts, tappets, valves, and lifters. There are, in fact, many more parts in a reciprocating engine than in a comparable rotary engine.

However, sealing at the apexes and sides of the rotor is critical for efficient operation of the rotary engine. Significant pressure differences between the three active mixture volumes of a rotor in different phases of the Otto cycle require efficient seals

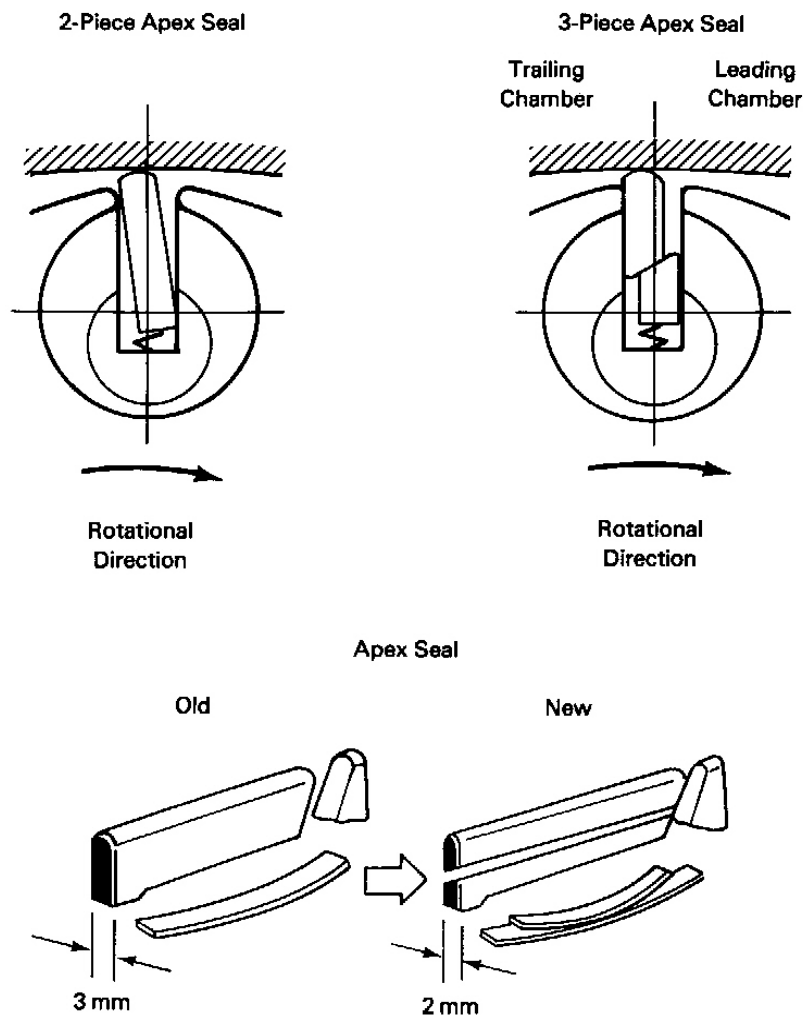

FIGURE 7.11 Design improvements in the apex seals of the Mazda RX-7 rotary engine. (Reprinted with permission. ©1987, Society of Automotive Engineers, Inc.) (See ref. 6.)

analogous to piston rings in the reciprocating engine. These are needed to avoid leakage between adjacent volumes, which causes a loss of compression and power. Seal friction has been estimated to account for about 25% of rotary engine friction. Spring loaded, self-lubricating apex seals, as shown in Figure 7.11, allow for sliding with low friction over the treated-chrome-alloy-plated housing inner surface.

The figure shows improvements in apex seal design (ref. 6). The three-piece seal design, with two leaf springs rather than one, decreases seal mass through reduced thickness, and offers a configuration that promotes area contact rather than line contact between seal and rotor. Side seals are also important to maintain pressure integrity of each flank mixture pocket. Reductions in the thickness of both apex and side seals have decreased friction with the housing by reducing the seal area producing the friction-

causing normal force on the housing. Oil seals, also on the rotor sides, are used to control oil consumption.

Though the peripheral intake port shown in Figures 7.4 and 7.9 provides better performance under heavy loads than a single side port, its associated intake-exhaust port overlap may allow excessive flow of exhaust gas into the fresh mixture, causing unreliable combustion in low-speed operation. Consequently, one or more side intake ports, in addition to or instead of a peripheral intake port, are sometimes used. Side ports, of course, are also opened and closed by rotor motion. In addition to reducing intake-exhaust overlap at light loads, side intake ports also induce combustion-enhancing swirl in the air-fuel mixture.

It is evident that the moving combustion volume at the time of ignition has a long and narrow flame propagation path. Rounded rotor flanks are usually recessed to provide a wider flame front path between the two lobes of the active volume. In high-speed operation, the brief time for combustion may dictate additional design features. Multiple spark plugs, swirl induced by side intake ports and multiple ports, the "squish" produced by the the relative motion of the walls of the active volume, fuel injection, and stratified-charge design all can contribute to improvement of the combustion process.

It may be noted in Figures 7.3 and 7.9 that an internal ring gear is attached to the rotor. This gear meshes with a stationary gear attached to the engine housing. The function of this gearset is to position the rotor as the shaft turns—not to transmit torque. Engine torque, as indicated earlier, is transmitted by direct contact of surface forces between the rotor and the eccentric.

Stratified-Charge Rotary Engine

Reference 7 discusses the design and performance of stratified-charge rotary engines developed for commercial aviation propulsion and APU (auxiliary power unit) application as well as for marine, industrial, and military requirements. Figure 7.12 shows a direct fuel injection configuration that has performed well under a wide range of speed, load, and environmental conditions and with a variety of liquid fuels. The reference reports a lack of octane and cetane sensitivities, so that diesel, gasoline, and jet fuel can all be used with this configuration.

As air in the rotor recess passes below, the spark plug ignites a locally rich pilot stream that in turn ignites the fuel from the main injector. The net fuel-air ratio is lean, resulting in improved fuel economy over normal carburetion. Figure 7.13 presents data for full-load brake horsepower and specific fuel consumption obtained with Jet-A fuel for the twin-rotor 2034R engine. The maximum takeoff power at 5800 rpm was 430 horsepower, with a brake specific fuel consumption (BSFC) of 0.44 lb_m/BHP-hr. Throughout a range of loads and altitude conditions the engine operates with a fuel-air ratio between 0.035 and 0.037, well below the stoichiometric value. The reference reports a best thermal efficiency of 35.8% (BSFC = 0.387 lb_m/BHP-hr) at 3500 rpm and 225-horsepower output.

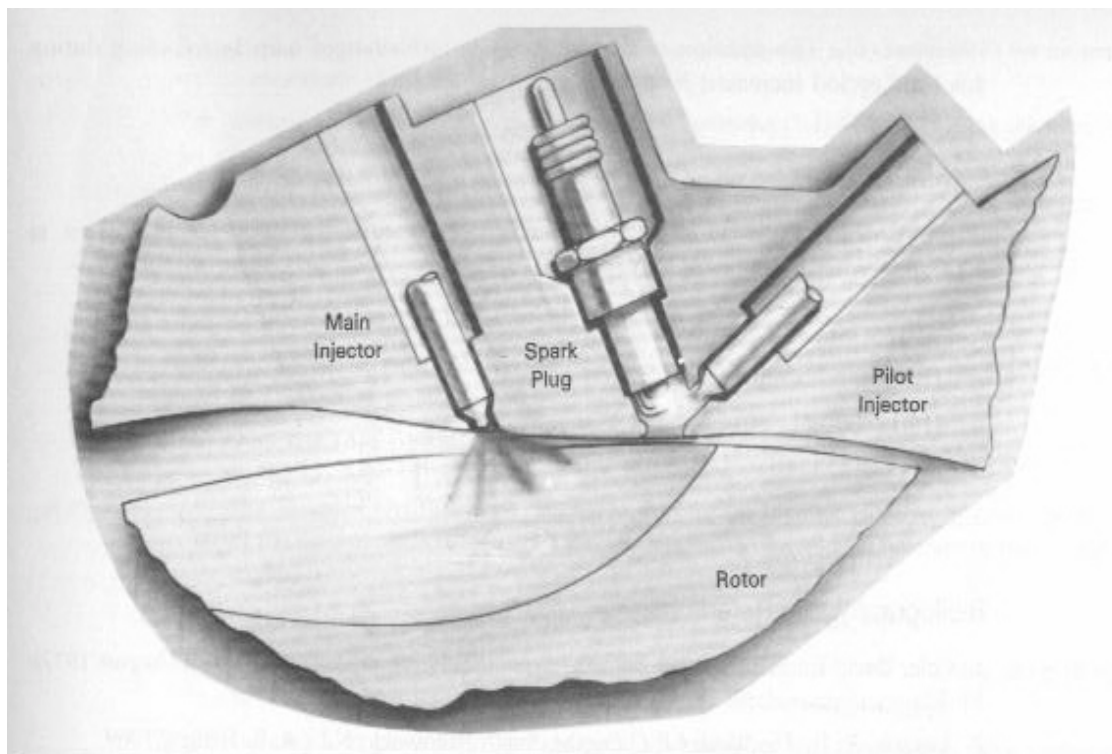

FIGURE 7.12 After top center pilot, dual injector configuration. (Courtesy of John Deere Technologies International Inc., Rotary Engine Div., Wood-Ridge, N.J.)

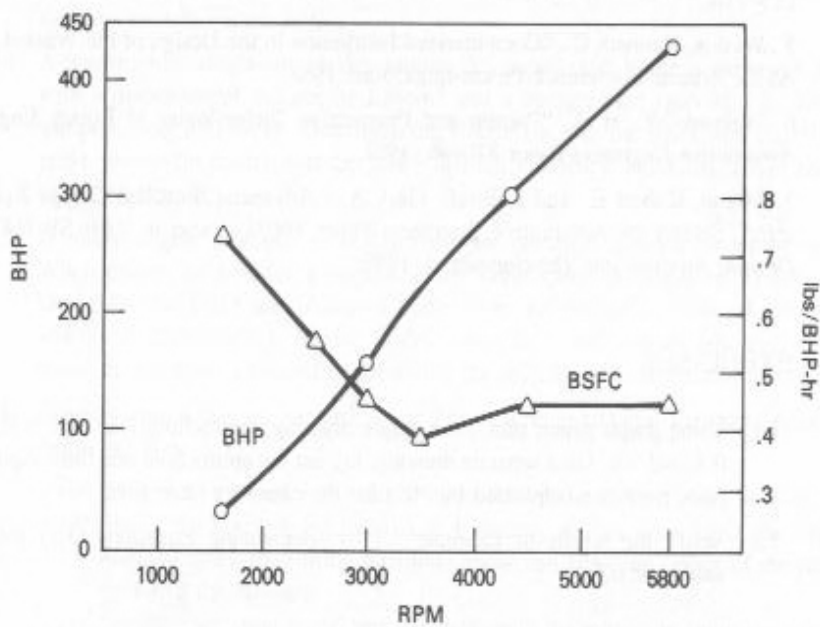

FIGURE 7.13 Stratified-charge rotary aircraft engine performance. (Courtesy of John Deere Technologies International Inc., Rotary Engine Div., Wood-Ridge, N.J.)

Closure

Continued engineering research on the rotary engine has resulted in performance improvements through improved seals, lean-burn combustion, fuel injection, integral electronic control, improved intake design, weight reduction, and turbocharging. Despite vehicle weight increases, the Mazda RX-7 with a two-rotor 80-in³-displacement engine improved 9.4% in fuel consumption and 8% in power output between 1984 and 1987 (ref. 6). During this time period, the addition to the engine of a turbocharger with intercooling increased its power output by 35%.

Reference 8 reports that the Mazda RX-Evolv, a year-2000 concept car, has a naturally-aspirated rotary engine called "RENESIS." The two-rotor, side intake and exhaust engine is reported to have reduced emissions and improved fuel economy and to have attained 280 horsepower at 9000 rpm and 226 N-m torque at 8000 rpm.

EXAMPLE 7.4

If the BMEP of the 11.89-in³-displacement engine in Example 7.2 is 150 psi at 4000 rpm, what is the brake horsepower?

Solution

The brake horsepower is

$$\text{BHP} = (150)(4000)(11.89)/(12)(33000) = 18 \text{ horsepower}$$

or

$$\text{BHP} = (18)(0.746) = 13.44 \text{ kW}$$

Bibliography and References

1. Cole, David E. "The Wankel Engine," *Scientific American*, Vol. 227, No. 2, (August 1972): 14–23.
2. Ansdale, R. F., *The Wankel R C Engine*. South Brunswick, N.J.: A. S. Barnes, 1969.
3. Yamamoto, Kenichi, *Rotary Engine*, Tokyo: Sankaido Co., 1981.
4. Weston, Kenneth C. "Computer Simulation of a Wankel Rotary Engine—Analysis and Graphics." Proceedings of the Conference of the Society for Computer Simulation, July 1986, pp. 213-216.
5. Weston, Kenneth C., "Computerized Instruction in the Design of the Wankel Rotary Engine." ASEE Annual Conference Proceedings, June 1988.

6. Fujimoto, Y. et al., "Present and Prospective Technologies of Rotary Engine." Society of Automotive Engineers Paper 870446, 1987.
7. Mount, Robert E., and LaBouff, Gary A., "Advanced Stratified-Charge Rotary Engine Design." Society of Automotive Engineers Paper 890324 (also in SAE SP-768, *Rotary Engine Design; Analysis and Developments*), 1989.
8. Jost, Kevin, (ed.), "Global Concepts—Mazda RX—Evolv," *Automotive Engineering International*, Vol 8, No.8, (August 2000), p 59.

EXERCISES

- 7.1 Using graph paper, plot, on a single sheet, epitrochoids for $e/R = 0, 0.15, 0.2, 0.25, 0.3,$ and 0.4 . On a separate sheet, draw the epitrochoid and the triangular rotor for three rotor positions (separated by 30°) for the case of $e/R = 0.15$.
- 7.2 Verify the results of Example 7.1 by specializing Equations (7.1) for the appropriate values of α .
- 7.3 Derive Equation (7.5) using a differential area given by $(x - x_f) dy$, where x_f is the constant x -coordinate of the flank.
- 7.4 Following the approach in the derivation of Equations (7.3)–(7.6), and using the notation of Figure 7.6, derive Equation (7.7).
- 7.5 Derive Equation (7.7) using a differential area $(y - y_f) dx$, where y_f is the constant y -coordinate of the flank.
- 7.6 Derive Equation (7.8).
- 7.7 Derive Equation (7.9).
- 7.8 Show that the radius of curvature for a circular-arc flank that touches the epitrochoid at its midpoint is given by
- $$r/R = 1 - e/R + 3(e/R)/(1 - 4e/R)$$
- 7.9 Use Equation (7.13) to derive an expression for the limiting value of e/R as a function of the flank included angle. Plot the limiting value of e/R as a function of the included angle.
- 7.10 Solve Example 7.3, accounting for a rotor flank recess of 3% of R^2w .

- 7.11 If combustion takes place in an engine rotor rotation interval of 40° in an engine operating at 8000 rpm, how much time is available for the combustion process?
- 7.12* Develop a single-column spreadsheet that determines the compression ratio, clearance ratio, and nondimensional displacement for a given value of e/R and flank-rounding angle. Use a copy command to replicate the column, forming a table of alternative design characteristics, for a reasonable range of rounding angles.
- 7.13* Use the spreadsheet graphics option to develop plots of compression ratio and clearance ratio, as seen in Figure 7.10.
- 7.14 A snowmobile single-rotor Wankel engine developed 6.65 brake horsepower at 5500 rpm with a displacement volume of 108 cc and a compression ratio of 8.5. The fuel consumption was $2.77 \text{ lb}_m/\text{hr}$. Determine the BMEP (in psi), the BSFC (in $\text{lb}_m/\text{hp}\cdot\text{min}$), the brake torque (in $\text{lb}_f\cdot\text{ft}$), and the brake thermal efficiency, assuming a fuel heating value of $18,900 \text{ Btu}/\text{lb}_m$.
- 7.15 A rotary engine mounted on a dynamometer develops $23 \text{ lb}_f\cdot\text{ft}$ of torque at 5000 rpm. When driven by a motor-generator at the same speed, a torque of $7 \text{ lb}_f\cdot\text{ft}$ is required. Determine the brake and indicated horsepower and the engine mechanical efficiency. What additional information is needed to determine the indicated mean effective pressure?
- 7.16 A rotary engine has an eccentricity of 2 in. and an equilateral triangular rotor with a tip radius of 10 in.
- Determine the major and minor diameters of the epitrochoidal housing.
 - Sketch the housing and its axes of symmetry and the rotor when it is in the nominal spark-plug firing position.
 - For the configuration of part (b), determine the minimum rotor clearance.
 - Write equations for the relations between the shaft speed (rpm), the spark plug firing rate (FR), and the rotor speed (RS). Identify any new symbols used.
- 7.17 A rotary engine has an eccentricity of 3 cm and an equilateral triangular rotor with a tip radius of 13 cm.
- Determine the major and minor diameters of the epitrochoidal housing.
 - Sketch the housing and its axes of symmetry and the rotor when it is in the nominal spark-plug firing position.
 - For the configuration of part (b), determine the minimum rotor clearance.

- (d) Write equations for the relations between the shaft speed (rpm), the spark plug firing rate (FR), and the rotor speed (RS). Identify any new symbols used.
- 7.18 A rotary engine with a flat-flanked rotor has a ratio of maximum to minimum housing inside diameters of 1.4. What is the engine compression ratio?
- 7.19 The major diameter of the epitrochoidal housing of a flat-flanked single-rotor industrial rotary engine is 39.6 inches. The engine turns at 1000 rpm while delivering 500 brake horsepower at a BMEP of 79.2 psi. If the eccentricity ratio is 0.14, what are the minor diameter, the rotor thickness, and the rotor displacement, [in³]?
- 7.20 A flat-flanked dual-rotor industrial rotary engine has a 60-cm minor diameter. The engine delivers 800kW from an IMEP of 700kPa at a shaft speed of 20 rps. The mechanical efficiency is 89%, and the eccentricity ratio is 0.16. Determine the major diameter and the thickness and displacement of each rotor.
- 7.21 A Wankel rotary engine has an eccentricity of 2.2 in. and a major diameter of 28 in. It has a compression ratio of 9.5 and a 600 in³ displacement. Determine the rotor width and the rotor sector included angle if the rotor flanks are circular and have no indentations.
- 7.22 A Wankel rotary engine has an eccentricity of 2.5 cm and a major diameter of 32 cm. The engine compression ratio is 9.0, and the displacement is 540 cm³. What are the eccentricity ratio, the rotor width, and the rotor sector included angle if the rotor flanks are circular and have no indentations?