

## CHAPTER 8

### REFRIGERATION AND AIR CONDITIONING

#### 8.1 Introduction

Up to this point we have considered fossil-fueled heat engines that are currently in use. These devices have provided society's answers to the thermodynamic question: How can the chemical energy of fossil fuels be converted into mechanical work and motive power? Let us now turn our attention to the another great thermodynamic question: How can thermal energy be transferred from cold to warmer regions?

The well-known *Clausius statement of the Second Law of Thermodynamics* asserts: *It is impossible to construct a device that, operating in a cycle, has no effect other than the transfer of heat from a cooler to a hotter body.* Thus the Clausius statement tells us that energy (heat) will not flow from cold to hot regions without outside assistance. The devices that provide this help are called *refrigeration units* and *heat pumps*. Both types of devices satisfy the Clausius requirement of external action through the application of mechanical power or natural transfers of heat (more on this later).

The distinction between refrigerator and heat pump is one of purpose more than technique. The refrigeration unit transfers energy (heat) from cold to hot regions for the purpose of cooling the cold region while the heat pump does the same thing with the intent of heating the hot region. The following will focus on refrigeration and make the distinction between refrigeration and heat pumps only when it is essential to the discussion.

It should be pointed out that any heat engine cycle, when reversed, becomes a refrigeration cycle, because the cyclic integral of the heat transfer, and thus the net work, becomes negative. This implies heat rejection at higher than the lowest cycle temperature.

The *vapor compression* refrigeration system is the mainstay of the refrigeration and air conditioning industry. *Absorption* refrigeration provides an alternative to the vapor compression approach, particularly in applications where a heat source is economical and readily available. This chapter considers both of these system types in turn, and closes with a discussion of moist air behavior and its influence on air conditioning system design.

Numerous other specialized refrigeration systems exist. As just stated, in principle any heat engine cycle, when reversed, becomes a refrigeration cycle. Such cycles are usually discussed in thermodynamics texts. Other systems that are occasionally used in special applications include thermoelectric coolers, which employ electrical work, and Hilsch or vortex tubes, which employ compressed gas as an energy source.

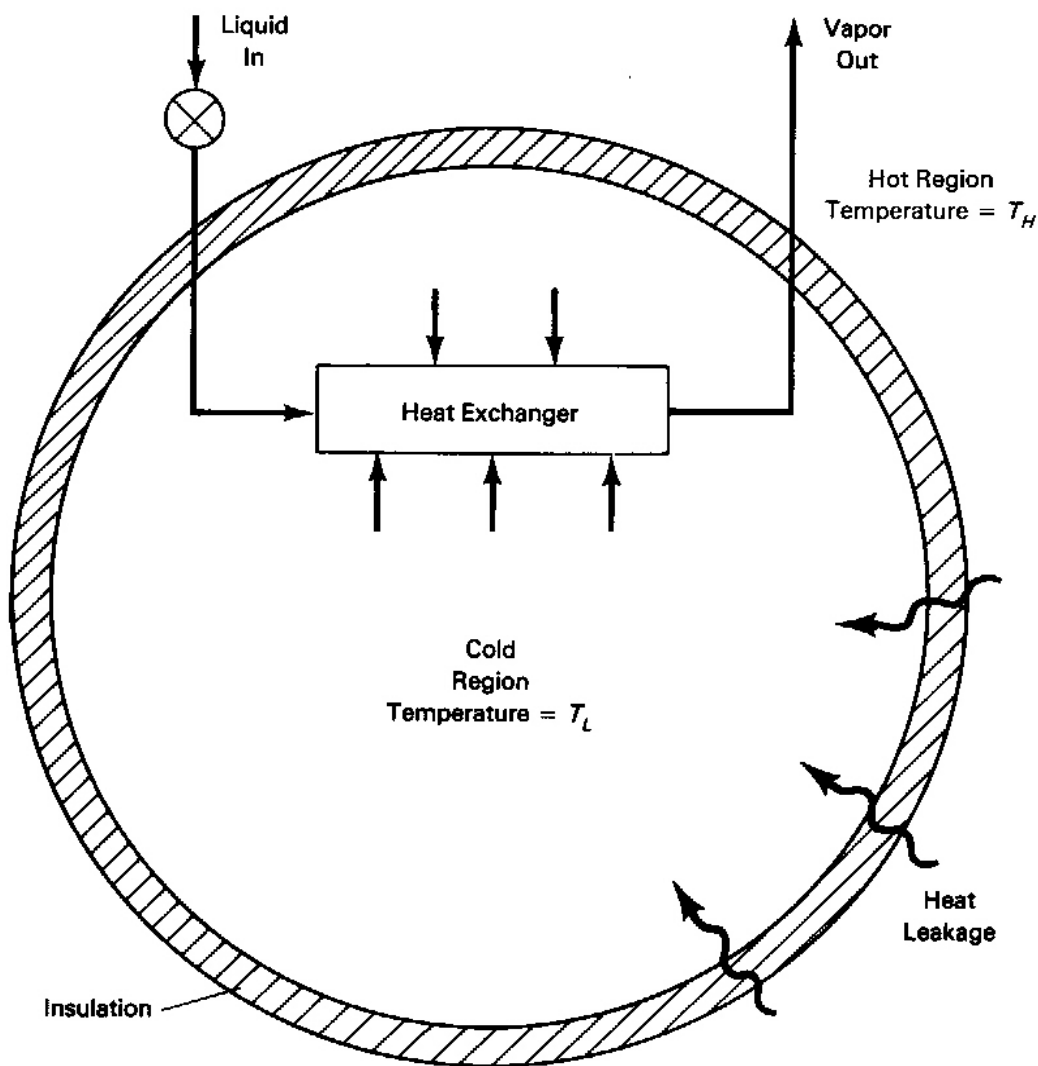

**FIGURE 8.1** Refrigeration concept.

## 8.2 Vapor Compression Refrigeration

Consider an insulated cold region of temperature  $T_L$  as shown in Figure 8.1. Heat leakage from the surroundings to the system tends to increase the system's temperature. In order to keep the cold region at temperature  $T_L$ , the conservation of energy requires the removal of an amount of heat equal to the energy inflow. This is done by a cold region heat exchanger that has an even colder liquid flowing through it to carry away the heat. If the fluid is a saturated liquid, it will evaporate and absorb energy from the cold region in its heat of vaporization. Such a heat exchanger is called an *evaporator*. Thus the basic problem of refrigeration may be reduced to one

of providing a mechanism to supply cool saturated liquid or a mixture of liquid and vapor, the *refrigerant*, to an evaporator.

*Vapor compression refrigeration*, as the name suggests, employs a compression process to raise the pressure of a refrigerant vapor flowing from an evaporator at pressure  $p_1$  to  $p_2$ , as shown in Figure 8.2. The refrigerant then flows through a heat exchanger called a *condenser* at the high pressure,  $p_2 = p_3$ , through a throttling device, and back to the low pressure,  $p_1$ , in the evaporator. The pressures  $p_2 = p_3$  and  $p_4 = p_1$  correspond to refrigerant saturation temperatures,  $T_3$  and  $T_1 = T_4$ , respectively. These temperatures allow natural heat exchange with adjacent hot and cold regions from high temperature to low. That is,  $T_1$  is less than  $T_L$ ; so that heat,  $Q_L$ , will flow from the cold region into the *evaporator* to vaporize the working fluid. Similarly, the temperature  $T_3$  allows heat,  $Q_H$ , to be transferred from the working fluid in the *condenser* to the hot region at  $T_H$ . This is indicated by the arrows of Figure 8.2.

Thus the resulting device is one in which heat is transferred from a low temperature,  $T_L$ , to a high temperature,  $T_H$ , using a compressor that receives work from the surroundings, therein satisfying the Clausius statement.

The *throttling device*, as shown in Figure 8.2, restrains the flow of refrigerant from the condenser to the evaporator. Its primary purpose is to provide the flow resistance necessary to maintain the pressure difference between the two heat exchangers. It also serves to control the rate of flow from condenser to evaporator. The throttling device may be a *thermostatic expansion valve* (TEV) controlled by evaporator exit temperature or a long, fine-bore pipe called a *capillary tube*.

For an adiabatic throttling device, the First Law of Thermodynamics requires that  $h_3 = h_4$  for the irreversible process, because  $Q$  and  $W$  are zero and kinetic energy change is negligible. Thus saturated liquid at  $T_3$  flashes to a mixture of liquid and vapor at the evaporator inlet at the enthalpy  $h_4 = h_3$  and pressure  $p_4 = p_1$ . Also the evaporator entrance has the quality  $x_4$  and temperature  $T_4 = T_1$ . Heat from the cold source at  $T_L > T_4$  boils the mixture in the evaporator to a saturated or slightly superheated vapor that passes to the *suction side* of the compressor.

The compressor in small and medium-sized refrigeration units is usually a reciprocating or other positive-displacement type, but centrifugal compressors often are used in large systems designed for commercial and industrial service.

It may be noted from the T-s diagram in Figure 8.2 that the vapor compression cycle is a reversed Rankine cycle, except that the pressure drop occurs through a throttling device rather than a turbine. In principle, a turbine or expansion device of some kind could be used to simultaneously lower the refrigerant pressure and produce work to reduce the net work required to operate the compressor. This is very unlikely because of the difficulty of deriving work from a mixture of liquid and vapor and because of the low cost and simplicity of refrigeration throttling devices.

An exploded view of a through-the-wall type room air conditioner commonly used in motels and businesses is shown in Figure 8.3. A fan coil unit on the space side is the evaporator. A thermally insulating barrier separates a hermetically sealed, electric-motor-driven positive displacement compressor unit and a finned-tube heat exchanger condenser from the room on the outdoor side.

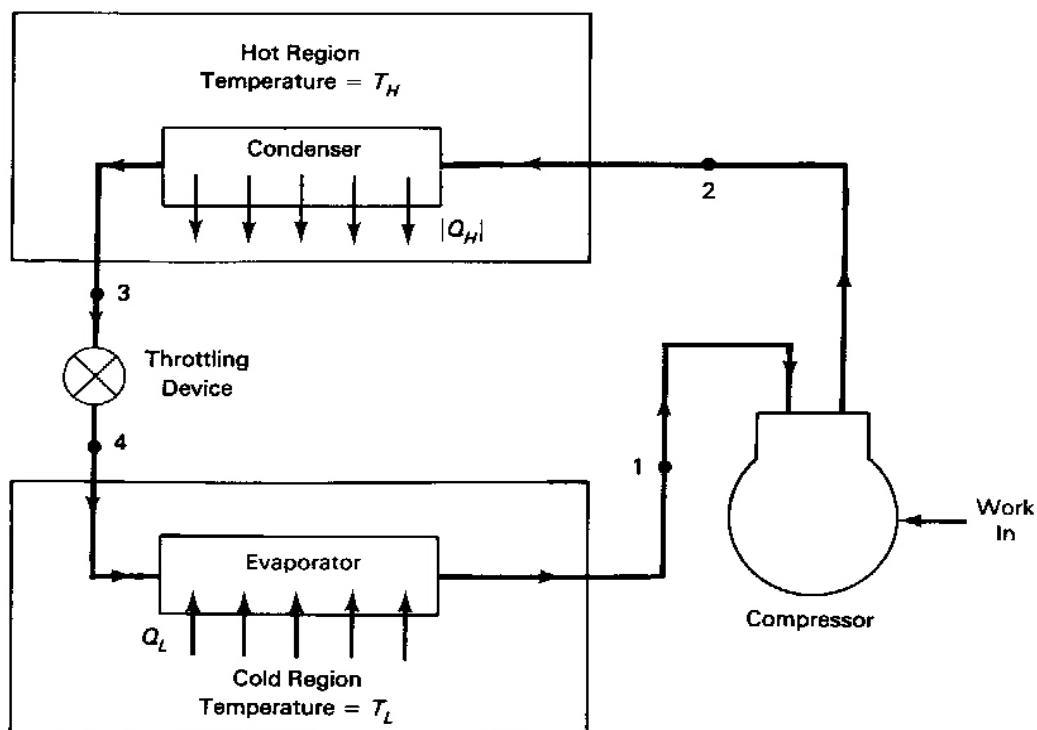

(a) Flow Diagram

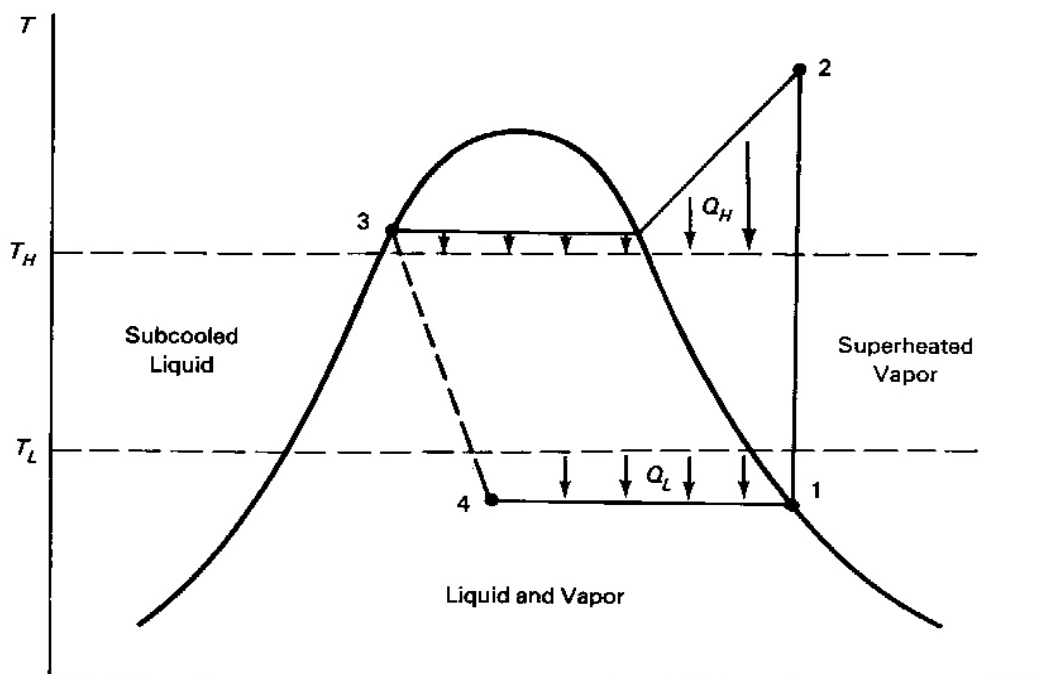

(b) Temperature-Entropy Diagram

**FIGURE 8.2** Ideal vapor compression cycle. Heat is transferred from a cold region at temperature  $T_L$  to a hot region at temperature  $T_H$ .

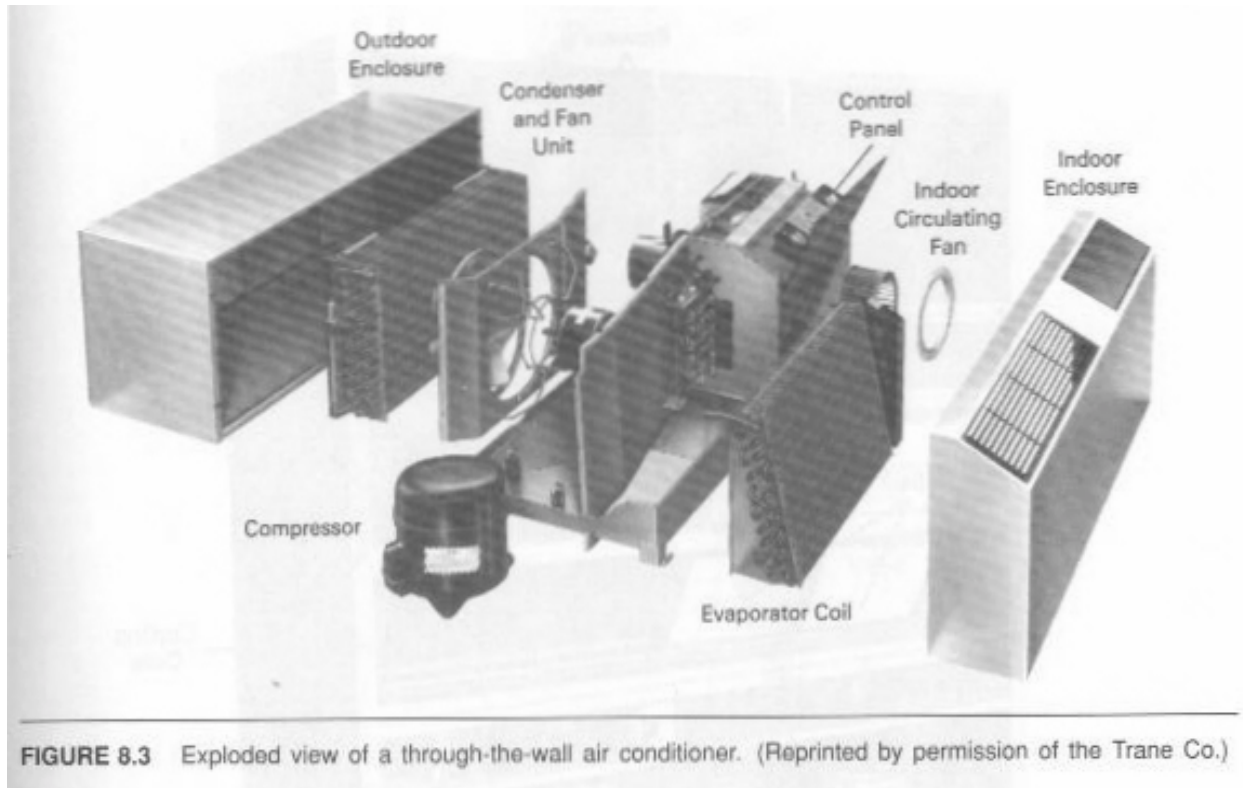

**FIGURE 8.3** Exploded view of a through-the-wall air conditioner. (Reprinted by permission of the Trane Co.)

Figure 8.4 shows a packaged air-conditioning unit designed for in-space use or for a nearby space with short duct runs. Units sometimes are designed to operate with either one or two compressors, coils, and fans to better accommodate varying cooling demands. A unit with water-cooled condensers such as that shown requires an external heat sink, usually provided by a nearby ground-level or rooftop evaporative cooling tower.

Rather than being combined in a single enclosure, refrigeration units frequently are installed as *split systems*. Figure 8.5 shows an uncovered rooftop *condensing unit* that contains a compressor and air cooled condenser. Such units are, of course, covered to resist the outdoor environment over many years. Cooled refrigerant is piped in a closed circuit to remote air distribution units that contain cooling coils (evaporators) and throttling devices. Figure 8.6 shows a skid-mounted air-cooled condensing unit also designed to function with remote evaporators in applications such as walk-in coolers.

## Refrigerants

Refrigerants are specially selected substances that have certain important characteristics including good refrigeration performance, low flammability and toxicity, compatibility with compressor lubricating oils and metals, and good heat transfer characteristics. They are usually identified by a number that relates to their molecular composition.

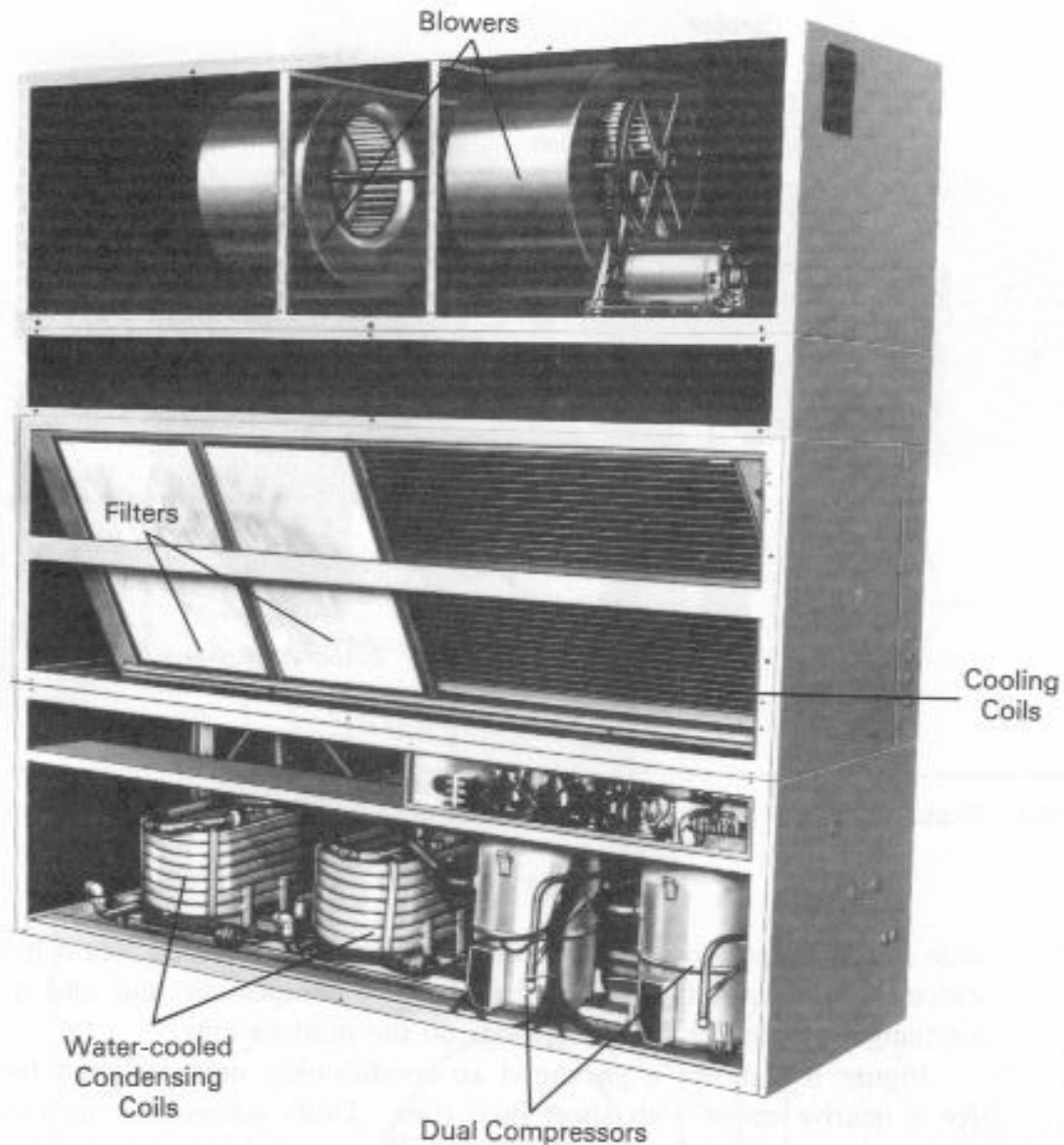

**FIGURE 8.4** Packaged air conditioner for in-space installation (cover panels removed). (Reprinted by permission of the Trane Co.)

The ASHRAE Handbook (ref. 1) identifies a large number of refrigerants by number, as shown in Table 8.1. Inorganic refrigerants are designated by 700, plus their molecular weight. For hydrocarbon and halocarbon refrigerants, the number scheme *XYZ* works as follows: (1) *Z*, on the right is the number of fluorine atoms; (2) *Y* is the number of hydrogen atoms plus one; and (3) the leftmost digit, *X*, is one less than the number of carbon atoms in the compound.

Two important examples are refrigerants R-12 and R-22. R-12, dichlorodifluoromethane, has two fluorine, one carbon, and two chlorine atoms in a methane-type structure. Thus the halogens,

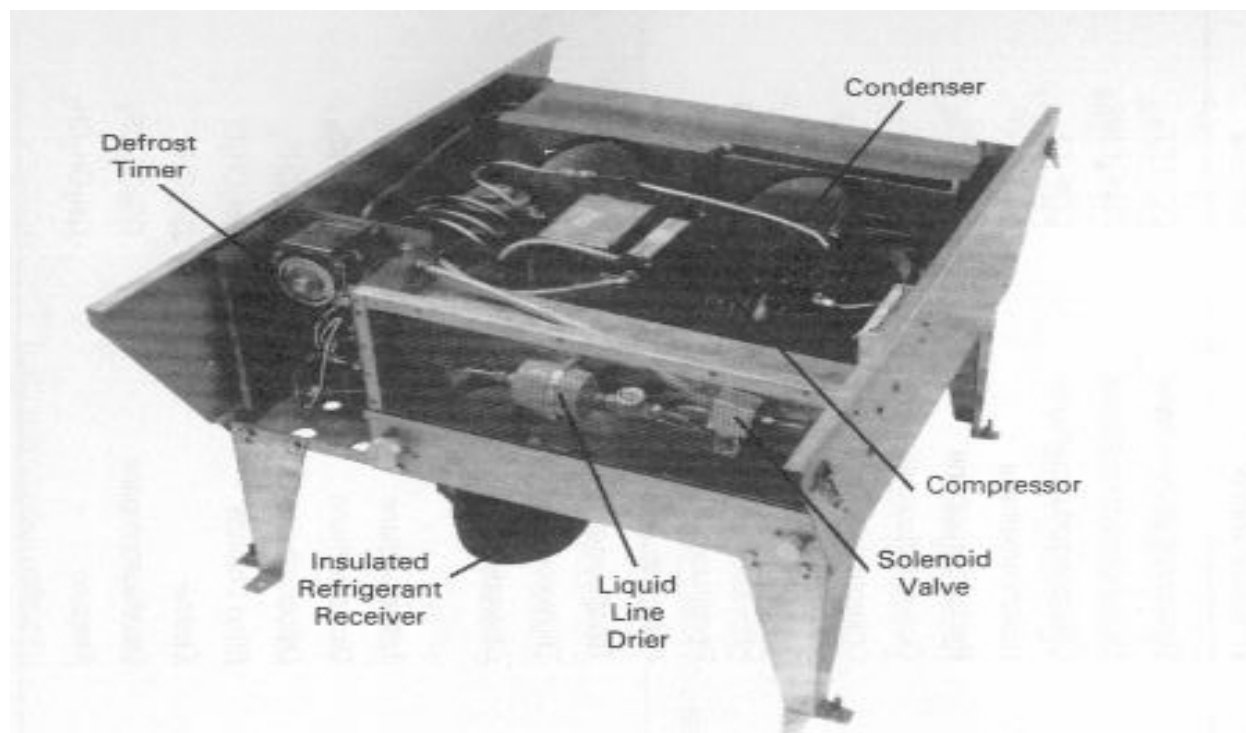

**FIGURE 8.5** Rooftop condensing unit for a split system. (Courtesy of Krack Corp.)

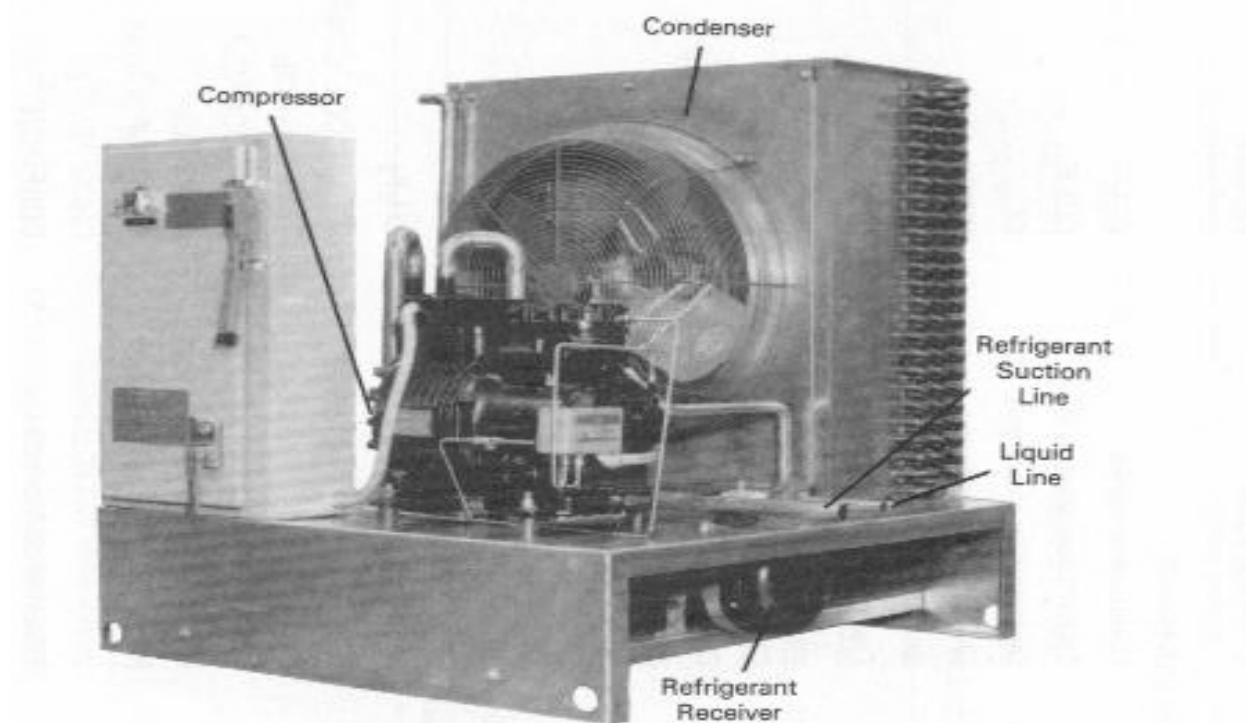

**FIGURE 8.6** Skid-mounted condensing unit. (Courtesy of Krack Corp.)

**TABLE 8.1** ASHRAE Standard Designation of Refrigerants (ANSI / ASHRAE Standard 34-78)

Refrigerant Number	Chemical Name	Chemical Formula	Refrigerant Number	Chemical Name	Chemical Formula
Halocarbon Compounds					
10	Carbontetrachloride	CCl <sub>4</sub>	114a	Dichlorotetrafluoroethane	CCl <sub>2</sub> FCF <sub>3</sub>
11	Trichlorofluoromethane	CCl <sub>3</sub> F	114B2	Dibromotetrafluoroethane	CBrF <sub>2</sub> CBBrF <sub>2</sub>
12	Dichlorodifluoromethane	CCl <sub>2</sub> F <sub>2</sub>	115	Chloropentafluoroethane	CClF <sub>2</sub> CF <sub>3</sub>
13	Chlorotrifluoromethane	CClF <sub>3</sub>	116	Hexafluoroethane	CF <sub>3</sub> CF <sub>3</sub>
13B1	Bromotrifluoromethane	CBrF <sub>3</sub>	120	Pentachloroethane	CHCl <sub>2</sub> CCl <sub>3</sub>
14	Carbontetrafluoride	CF <sub>4</sub>	123	Dichlorotrifluoroethane	CHCl <sub>2</sub> CF <sub>3</sub>
			124	Chlorotetrafluoroethane	CHClFCF <sub>3</sub>
20	Chloroform	CHCl <sub>3</sub>	124a	Chlorotetrafluoroethane	CHF <sub>2</sub> CClF <sub>2</sub>
21	Dichlorofluoromethane	CHCl <sub>2</sub> F	125	Pentafluoroethane	CHF <sub>2</sub> CF <sub>3</sub>
22	Chlorodifluoromethane	CHClF <sub>2</sub>	133a	Chlorotrifluoroethane	CH <sub>2</sub> ClCF <sub>3</sub>
23	Trifluoromethane	CHF <sub>3</sub>	134a	Tetrafluoroethane	CF <sub>3</sub> CH <sub>2</sub> F
30	Methylene Chloride	CH <sub>2</sub> Cl <sub>2</sub>	140a	Trichloroethane	CH <sub>3</sub> CCl <sub>3</sub>
31	Chlorofluoromethane	CH <sub>2</sub> ClF	142b	Chlorodifluoroethane	CH <sub>3</sub> CClF <sub>2</sub>
32	Methylene Fluoride	CH <sub>2</sub> F <sub>2</sub>	143a	Trifluoroethane	CH <sub>3</sub> CF <sub>3</sub>
40	Methyl Chloride	CH <sub>3</sub> Cl	150a	Dichloroethane	CH <sub>3</sub> CHCl <sub>2</sub>
41	Methyl Fluoride	CH <sub>3</sub> F	152a	Difluoroethane	CH <sub>3</sub> CHF <sub>2</sub>
50*	Methane	CH <sub>4</sub>	160	Ethyl Chloride	CH <sub>3</sub> CH <sub>2</sub> Cl
110	Hexachloroethane	CCl <sub>3</sub> CCl <sub>3</sub>	170*	Ethane	CH <sub>3</sub> CH <sub>3</sub>
111	Pentachlorofluoroethane	CCl <sub>3</sub> CCl <sub>2</sub> F	218	Octafluoropropane	CF <sub>3</sub> CF <sub>2</sub> CF <sub>3</sub>
112	Tetrachlorodifluoroethane	CCl <sub>2</sub> FCCl <sub>2</sub> F	290*	Propane	CH <sub>3</sub> CH <sub>2</sub> CH <sub>3</sub>
112a	Tetrachlorodifluoroethane	CCl <sub>3</sub> CClF <sub>2</sub>	Cyclic Organic Compounds		
113	Trichlorotrifluoroethane	CCl <sub>2</sub> FCClF <sub>2</sub>	C316	Dichlorohexafluorocyclobutane	C <sub>4</sub> Cl <sub>2</sub> F <sub>6</sub>
113a	Trichlorotrifluoroethane	CCl <sub>3</sub> CF <sub>3</sub>	C317	Chlorohexafluorocyclobutane	C <sub>4</sub> ClF <sub>7</sub>
114	Dichlorotetrafluoroethane	CClF <sub>2</sub> CClF <sub>2</sub>	C318	Octafluorocyclobutane	C <sub>4</sub> F <sub>8</sub>

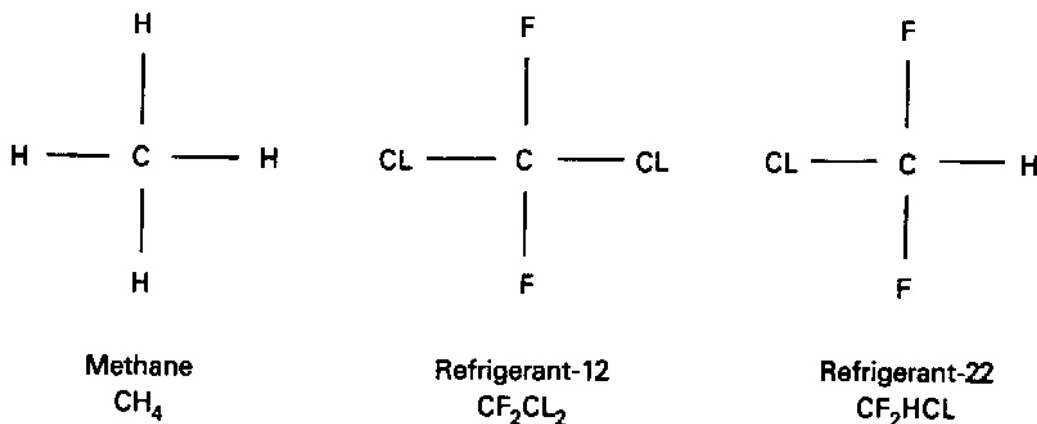

TABLE 8.1 (continued)

Refrigerant Number	Chemical Name	Chemical Formula	Refrigerant Number	Chemical Name	Chemical Formula
<b>Azeotropes</b>					
500	Refrigerants 12 / 152a (73.8 / 26.2)	$\text{CCl}_2\text{F}_2 / \text{CH}_3\text{CHF}_2$		Inorganic Compounds	
501	Refrigerants 22 / 12 (75 / 25)	$\text{CHClF}_2 / \text{CCl}_2\text{F}_2$	702	Hydrogen (Normal and Para)	$\text{H}_2$
502	Refrigerants 22 / 115 (48.8 / 51.2)	$\text{CHClF}_2 / \text{CClF}_2\text{CF}_3$	704	Helium	He
503	Refrigerants 23 / 13 (40.1 / 59.9)	$\text{CHF}_3 / \text{CClF}_3$	717	Ammonia	$\text{NH}_3$
504	Refrigerants 32 / 115 (48.2 / 51.8)	$\text{CH}_2\text{F}_2 / \text{CClF}_2\text{CF}_3$	718	Water	$\text{H}_2\text{O}$
505	Refrigerants 12 / 31 (78.0 / 22.0)	$\text{CCl}_2\text{F}_2 / \text{CH}_2\text{ClF}$	720	Neon	Ne
506	Refrigerants 31 / 114 (55.1 / 44.9)	$\text{CH}_2\text{ClF} / \text{CClF}_2\text{CClF}_2$	728	Nitrogen	$\text{N}_2$
			729	Air	.21 $\text{O}_2$ , .78 $\text{N}_2$ , .01A
			732	Oxygen	$\text{O}_2$
			740	Argon	A
			744	Carbon Dioxide	$\text{CO}_2$
			744A	Nitrous Oxide	$\text{N}_2\text{O}$
			764	Sulfur Dioxide	$\text{SO}_2$
<b>Miscellaneous Organic Compounds</b>					
<b>Hydrocarbons</b>					
50	Methane	$\text{CH}_4$		Unsaturated Organic Compounds	
170	Ethane	$\text{CH}_3\text{CH}_3$	1112A	Dichlorodifluoroethylene	$\text{CCl}_2 = \text{CF}_2$
290	Propane	$\text{CH}_3\text{CH}_2\text{CH}_3$	1113	Chlorotrifluoroethylene	$\text{CClF} = \text{CF}_2$
600	Butane	$\text{CH}_3\text{CH}_2\text{CH}_2\text{CH}_3$	1114	Tetrafluoroethylene	$\text{CF}_2 = \text{CF}_2$
600a	Isobutane (2 methyl propane)	$\text{CH}(\text{CH}_3)_3$	1120	Trichloroethylene	$\text{CHCl} = \text{CCl}_2$
1150†	Ethylene	$\text{CH}_2 = \text{CH}_2$	1130	Dichloroethylene	$\text{CHCl} = \text{CHCl}$
1270†	Propylene	$\text{CH}_3\text{CH} = \text{CH}_2$			
<b>Oxygen Compounds</b>					
610	Ethyl Ether	$\text{C}_2\text{H}_5\text{OC}_2\text{H}_5$	1132a	Vinylidene Fluoride	$\text{CH}_2 = \text{CF}_2$
611	Methyl Formate	$\text{HCOOCH}_3$	1140	Vinyl Chloride	$\text{CH}_2 = \text{CHCl}$
			1141	Vinyl Fluoride	$\text{CH}_2 = \text{CHF}$
			1150	Ethylene	$\text{CH}_2 = \text{CH}_2$
			1270	Propylene	$\text{CH}_3\text{CH} = \text{CH}_2$
<b>Nitrogen Compounds</b>					
630	Methyl Amine	$\text{CH}_3\text{NH}_2$			
631	Ethyl Amine	$\text{C}_2\text{H}_5\text{NH}_2$			

\* Methane, ethane, and propane appear in the Halocarbon section in their proper numerical order, but these compounds are not halocarbons.

† Ethylene and propylene appear in the Hydrocarbon section to indicate that these compounds are hydrocarbons, but they are properly identified in the section on Unsaturated Organic Compounds.



**FIGURE 8.7** Comparison of some refrigerant molecular structures.

chlorine and fluorine, replace hydrogen atoms in the CH<sub>4</sub> molecular structure as shown in Figure 8.7. R-22, monochlorodifluoromethane, has a similar structure to R-12, except for a single hydrogen atom replacing a chlorine atom. Charts of the thermodynamic properties of these refrigerants are given in Appendix F.

The commonly used chlorofluorocarbon (CFC) refrigerants are a cause of great concern, because their accumulation in the upper atmosphere creates a “hole” in the ozone layer that normally shields the earth from solar ultraviolet radiation (refs. 8 and 9). In 1987, more than 35 countries, including the United States, signed the Montreal Protocol on Substances that Deplete the Ozone Layer. The Montreal Protocol called for a freeze in 1989 and reductions in the 1990s on the production levels of R-11, R-12, R-113, R-114, and R-115. The halocarbon refrigerants, some of which are also widely used as aerosol propellants, foams, and solvents, are now categorized as chlorofluorocarbons (CFCs), hydrochlorofluorocarbons (HCFCs), or hydrofluorocarbons (HFCs). The HFCs, lacking chlorine, are no threat to the ozone layer but are not in common usage as refrigerants. CFCs, which contain more chlorine than do HCFCs, are the most serious offenders, are very stable, and do not break down rapidly in the lower atmosphere. The Clean Air Act of 1990 (ref. 15) mandated termination of production in the United States of all CFCs such as R-12 by the year 2000. Government data indicate that, because of the structural difference between them, R-12 has twenty times the ozone-depletion potential in the upper atmosphere of R-22. Nevertheless, R-22 and other HCFCs are also scheduled by the law for phaseout of production by the year 2030.

Thus, the search for alternate refrigerants to replace those used in existing applications (worth hundreds of billions of dollars) has assumed enormous importance. It is a difficult, expensive, and continuing task to which industry is vigorously applying its efforts. Charts of thermodynamic properties for two of the newer refrigerants, R-123 and R134a, are given in Appendix F.

## Vapor-Compression Cycle Analysis

A vapor-compression cycle was shown in Figure 8.2. The work required by the refrigeration compressor, assuming adiabatic compression, is given by the First Law of Thermodynamics:

$$w = h_1 - h_2 \quad [\text{Btu/lb}_m \mid \text{kJ/kg}] \quad (8.1)$$

where the usual thermodynamic sign convention has been employed. The enthalpies  $h_1$  and  $h_2$  usually are related to the temperatures and pressures of the cycle through the use of charts of refrigerant thermodynamic properties such as those given in Appendix F.

In the ideal vapor compression cycle, the compressor suction state 1 is assumed to be a saturated vapor. The state is determined when the evaporator temperature or pressure is given. For the ideal cycle, for which compression is isentropic, and for cycles for which the compression is determined using a compressor efficiency, state 2 may be defined from state 1 and the condensing temperature or pressure by using the chart of refrigerant thermodynamic properties. Assuming no heat exchanger pressure losses, the evaporator and condenser heat transfers are easily determined per unit mass of refrigerant by application of the First Law of Thermodynamics:

$$q_L = h_1 - h_4 \quad [\text{Btu/lb}_m \mid \text{kJ/kg}] \quad (8.2)$$

$$q_H = h_3 - h_2 \quad [\text{Btu/lb}_m \mid \text{kJ/kg}] \quad (8.3)$$

The evaporator heat transferred,  $q_L$ , is commonly referred to as the *refrigeration effect*, RE. The product of the refrigerant mass flow rate and RE, the rate of cooling produced by the unit, is called the *refrigeration capacity* [Btu/hr | kW].

Applying the First Law to the refrigerant in the system as a whole, we find that the work and heat-transfer terms are related by

$$q_L + q_H = w \quad [\text{Btu/lb}_m \mid \text{kJ/kg}] \quad (8.4)$$

where  $q_H$  and  $w$  are negative for both refrigerators and heat pumps. Hence

$$q_L + |w| = |q_H| \quad [\text{Btu/lb}_m \mid \text{kJ/kg}] \quad (8.5)$$

Equation (8.5) is written here with absolute values to show that the sum of the compressor work and the heat from the low-temperature source is the energy transferred by the condenser to the high-temperature region. This may be seen graphically by addition of the enthalpy increments representing Equations (8.1) to (8.3) in the pressure-enthalpy diagram shown in Figure 8.8. The p-h diagram is applied often in refrigeration work because of its ease of use in dealing with enthalpy differences and constant-pressure processes.

### EXAMPLE 8.1

Derive Equation (8.1) by using Equations (8.2) to (8.4).

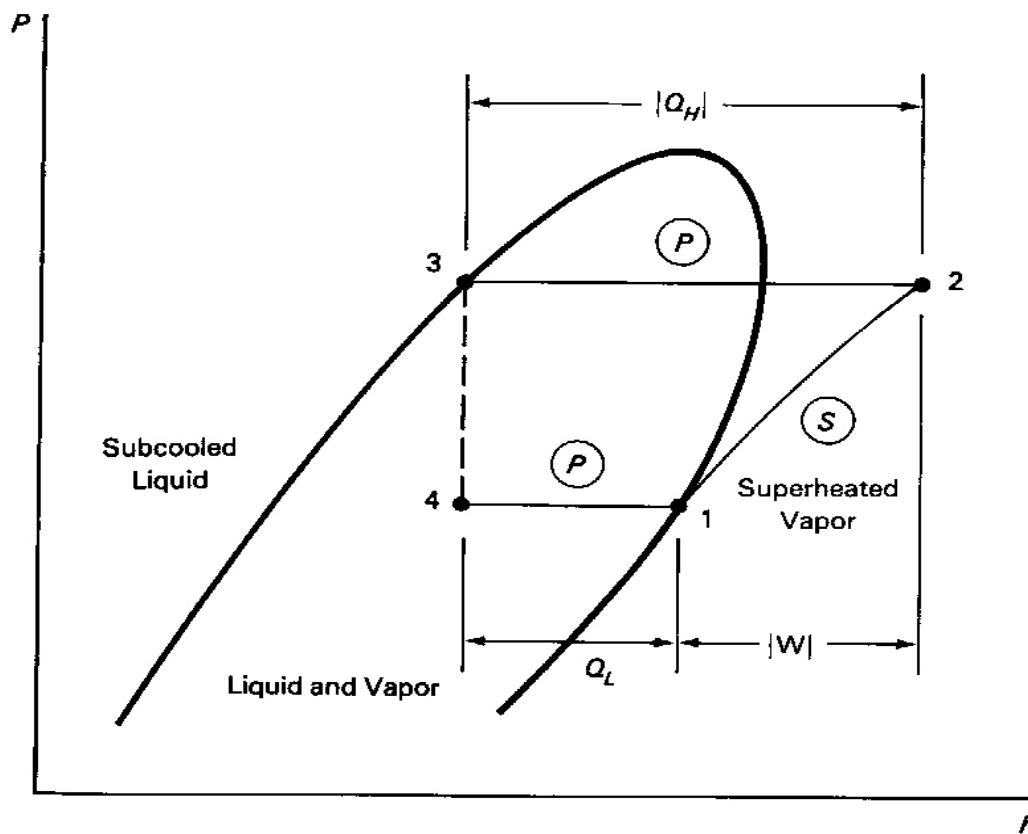

**FIGURE 8.8** Pressure–enthalpy diagram of the ideal vapor compression cycle.

Solution

From Equation (8.4),

$$w = q_L + q_H = (h_1 - h_4) + (h_3 - h_2)$$

But for the adiabatic throttling valve,  $h_3 = h_4$ . Hence,

$$w = h_1 - h_2$$

as in Equation (8.1).

### System Performance

As mentioned in Chapter 1, a measure of the efficiency of a refrigerator or heat pump is the *coefficient of performance*, COP. The *COP for a refrigerator* is defined as the ratio of the useful

effect or desired energy transfer accomplished by the evaporator (RE) to the energy cost to achieve the effect (the compressor work), in equivalent units:

$$\text{COP}_r = q_L/|w| \quad [\text{dl}] \quad (8.6)$$

Like a refrigerator, a heat pump may be a vapor compression system; but unlike the refrigerator it takes energy from a cold source and transfers it to a hot region for the purpose of raising the temperature of the region or compensating for heat losses from the region. Some commercial heat pumps are systems that combine both cooling and heating actions in a single package. These systems are discussed more fully later.

For a heat pump, the useful effect or desired energy transfer is the passage of energy from the condenser to the high-temperature region at  $T_H$ . Thus the *COP for a heat pump* is

$$\text{COP}_{\text{hp}} = |q_H| / |w| \quad [\text{dl}] \quad (8.7)$$

It is evident from Equations (8.6) and (8.7) that high values of COP are desired and may be achieved by minimizing the compressor work input for given values of heat transfer. It may be particularly advantageous to apply a vapor compression system in situations and applications in which simultaneous heating and cooling functions are required—to cool a computer room with the evaporator while heating rooms on the cold side of the building with the condenser, for example.

#### EXAMPLE 8.2

Show that the COP for a heat pump exceeds 1.

#### Solution

Combining Equations (8.7) and (8.5) yields

$$\begin{aligned} \text{COP}_{\text{hp}} &= |q_H| / |w| = (q_L + |w|) / |w| \\ &= 1 + q_L / |w| = 1 + \text{COP}_r > 1 \end{aligned}$$

Thus, because  $q_L > 0$  and  $\text{COP}_r > 0$ , the heat pump COP must always exceed 1. This is also evident directly from the definition Equation (8.7) because the First Law [Equation (8.5)] requires that  $|q_H| > |w|$ . Note the relationship of refrigerator and heat pump COPs for the same cycle.

The T-s diagram in Figure 8.2 shows that condenser and evaporator pressures of both refrigerators and heat pumps are determined largely by the source and sink (cold-region and hot-region) temperatures,  $T_L$  and  $T_H$ , respectively. Thus, the greater the difference between the hot-region and cold-region temperatures (the application temperature difference), the higher the compressor pressure ratio and the higher the compressor work. For low application temperature differences,  $|w|$  can be significantly less than  $q_L$ ; and thus  $\text{COP}_r$  may also exceed 1. Conversely, large application temperature differences lead to low coefficients of performance.

Prior to the twentieth century, the cooling of both people and perishable goods was achieved by using ice formed in the winter by nature from liquid water. Ice from lakes and ponds in northern climates was cut, hauled to ice storage houses, and delivered to customers as needed.

As late as the 1930s and '40s, the ice vendor would make a daily delivery of ice so that perishable goods could be kept fresh in insulated ice storage boxes, the predecessors of the modern refrigerator. By then, ice was being made by freezing water via large refrigeration units with ammonia compressors; and comfort air cooling was being installed in the best theaters and wealthiest homes in the United States.

It is not surprising that a measure of rate of cooling, or cooling capacity, is often related to the cooling capability of a ton of ice. A *ton of refrigeration* is defined as the rate of cooling produced by melting a ton of ice in 24 hours. Based on this definition, and on the fact that the latent heat of fusion of water is 144 Btu/lb<sub>m</sub>, it may be deduced that a ton of refrigeration is a rate of cooling of 200 Btu/min, or 12,000 Btu/hour (see Exercise 8.3). Thus a 3-ton air conditioner is one that nominally removes 36,000 Btu/hr from the cooled space.

When shopping for an air conditioner, one encounters labels that give the product's *energy efficiency ratio* (EER), that is, the ratio of the cooling capacity of the unit, measured in Btu/hr, to the power required to operate it, in watts. It is evident that the EER is proportional to the COP, neglecting fan power. Applying the conversion factor between Btus and watt-hours one sees that  $EER = 3.413 \cdot COP$ .

### EXAMPLE 8.3

For an ideal vapor compression refrigeration system operating with refrigerant 22 at an evaporator temperature of 0°F and condensing at 100°F, find the following: the compressor suction and discharge pressures, enthalpies, and specific volumes; the condenser discharge pressure and enthalpy; the refrigeration COP; and the refrigerant mass flow rate and power requirement for a 10-ton refrigeration unit.

#### Solution

Following the notation of Figures 8.2 and 8.8, from the chart (Appendix F) for *refrigerant 22* at  $T_1 = 0^\circ\text{F}$ , the other properties at state 1 are  $p_1 = 38$  psia,  $h_1 = 104$  Btu/lb<sub>m</sub>,  $v_1 = 1.4$  ft<sup>3</sup>/lb<sub>m</sub>, and  $s_1 = 0.229$  Btu/lb<sub>m</sub>-R.

The saturated-liquid condenser discharge properties at  $T_3 = 100^\circ\text{F}$  are  $p_3 = 210$  psia and  $h_3 = 39$  Btu/lb<sub>m</sub>.

The compressor discharge-state properties at  $s_2 = s_1$  and  $p_2 = p_3 = 210$  psia are  $h_2 = 123$  Btu/lb<sub>m</sub>,  $T_2 = 155^\circ\text{F}$ , and  $v_2 = 0.31$  ft<sup>3</sup>/lb<sub>m</sub>.

The evaporator inlet enthalpy is the same as that at condenser discharge,  $h_4 = h_3 = 39$  Btu/lb<sub>m</sub>.

The refrigeration effect and the compressor work are then

$$RE = h_1 - h_4 = 104 - 39 = 65 \text{ Btu/lb}_m$$

$$w = h_2 - h_1 = 123 - 104 = 19 \text{ Btu/lb}_m$$

Thus

$$\text{COP}_r = \text{RE} / w = 65/19 = 3.42.$$

The rate of cooling, or cooling capacity, for a 10-ton unit is  $10 \times 200 = 2000$  Btu/min. The refrigerant mass flow rate is the capacity divided by the refrigeration effect =  $2000/65 = 30.8$  lb<sub>m</sub>/min.

The power required by the compressor is the product of the mass flow rate and the compressor work =  $30.8 \times 19 = 585.2$  Btu/min, or  $585.2 \times 60 / 3.413 = 10,290$  W, or 10.29 kW.

The ideal EER may then be calculated from the capacity and power as  $2000 \times 60 / 10,290 = 11.7$  Btu/Watt-hr, or from the COP as  $3.413 \times 3.42 = 11.7$  Btu/Watt-hr.

## Compressors

While most small- and medium-capacity refrigeration systems use hermetically sealed, electric-motor-driven compressor units or open (externally powered) reciprocating compressors, centrifugal compressors are frequently found in large units for cooling buildings and for industrial applications.

The reciprocating compressor has much in common geometrically with a simple two-stroke reciprocating engine with intake and exhaust valves. As in that case, the compressor clearance volume  $V_c$  is the volume at top center, and the piston sweeps out the displacement volume, as indicated in Figure 8.9. The processes 1-2-3-4-1 on the idealized pressure-volume diagram represent the following:

- 1–2 Both valves are closed. Compression of the maximum cylinder volume  $V_1 = V_c + V_d$  of refrigerant vapor through the pressure ratio  $p_2/p_1$  to a volume  $V_2$ .
- 2–3 Exhaust valve is open. Discharge of refrigerant through the exhaust valve at condenser pressure  $p_3$  until only the clearance volume  $V_3 = V_c$  remains when the piston is at top center.
- 3–4 Both valves are closed. Expansion of the clearance gas with both valves closed from  $V_3$  to  $V_4$ . Note that the inlet valve cannot open until the cylinder pressure drops to  $p_4 = p_1$  without discharging refrigerant back into the evaporator.
- 4–1 Intake valve is open. Refrigerant is drawn from the evaporator into the cylinder at constant pressure  $p_1$  through an intake valve by the motion of piston. Refrigerant in the amount  $V_1 - V_4$  is processed per cycle.

Assuming polytropic compression and expansion processes with the same exponent  $k$ :

$$V_4 = V_3 (p_3/p_4)^{1/k} = V_c (p_2/p_1)^{1/k}$$

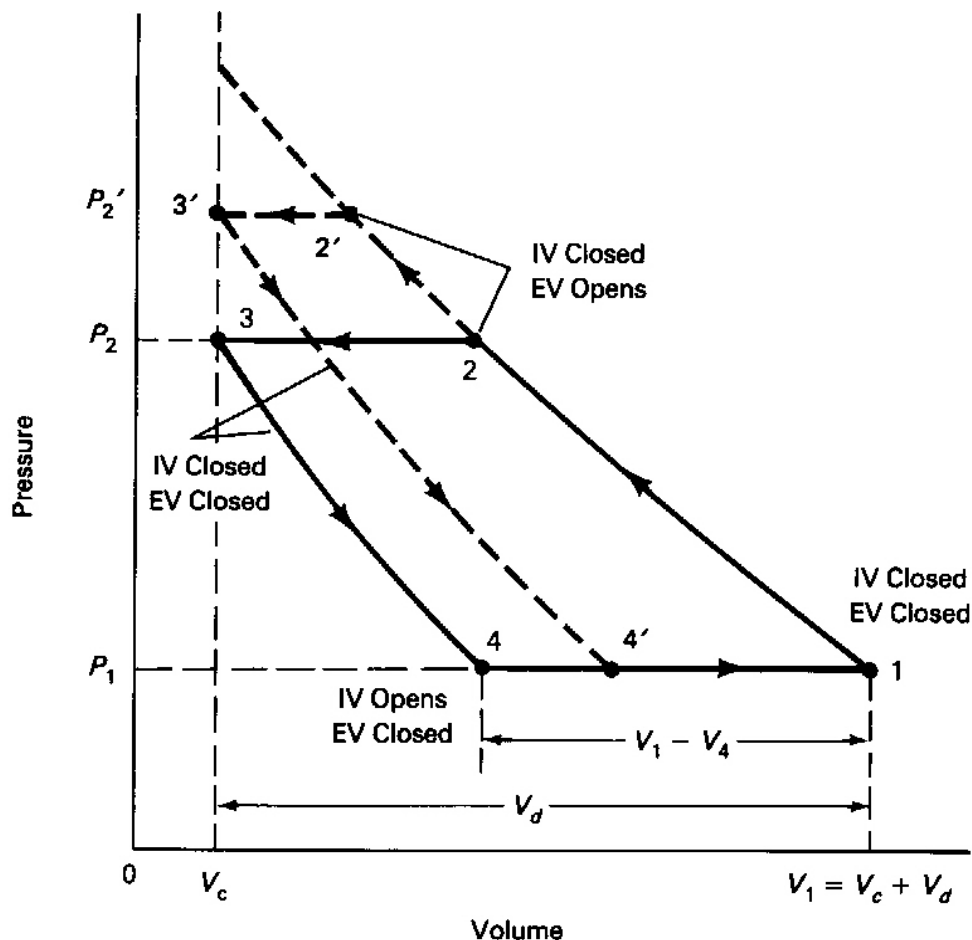

**FIGURE 8.9** Effect of pressure ratio and clearance volume on reciprocating compressor volumetric efficiency. (IV, intake valve; EV, exhaust valve.)

Then the volume of refrigerant vapor processed per cycle (or per shaft revolution)

$$V_1 - V_4 = V_d + V_c - V_c (p_2/p_1)^{1/k} = V_d - V_c [(p_2/p_1)^{1/k} - 1]$$

is less than the displacement volume and depends on the compressor pressure ratio. Neglecting the difference between the refrigerant density leaving the evaporator and that in the compressor cylinder just before compression, we may write the compressor volumetric efficiency as the ratio of  $V_1 - V_4$  to the displacement:

$$\eta_v = (V_1 - V_4)/V_d = 1 - (V_c/V_d) [(p_2/p_1)^{1/k} - 1]$$

Examination of the compressor processes for different pressure ratios, as in Figure 8.9 ( $p_2'/p_1$ , for example), shows that the refrigerant volume processed per cycle, and thus the volumetric



efficiency, decreases with increasing pressure ratio. It is also evident that the clearance volume must be kept small to attain high volumetric efficiency. It is clear that, for a given positive-displacement compressor, the volumetric efficiency limits the usable pressure ratio and thus the difference between the condensing and evaporating temperatures.

#### EXAMPLE 8.4

What is the volumetric efficiency of the reciprocating compressor used with the refrigeration system of Example 8.3 if the clearance volume is 3% of the displacement volume and the polytropic exponent is 1.16?

#### Solution

The compressor pressure ratio is  $p_2/p_1 = 210/38 = 5.526$ . From the preceding equation, the volumetric efficiency is then

$$\eta_v = 1 - (0.03) [(5.526)^{1/1.16} - 1] = 0.899$$

The centrifugal compressor used in refrigeration is similar in principle to that introduced earlier in connection with the turbocharger. It is fundamentally different than the positive-displacement reciprocating compressor in that it operates on a fluid dynamic principal in which kinetic energy imparted to the refrigerant by an impeller is converted to pressure analogous to that indicated by the Bernoulli equation. The high-speed rotor accelerates and thus increases the kinetic energy of the refrigerant, which is then converted to pressure in diffuser passages. Because the efficiency of small centrifugal compressors is limited, centrifugals are used primarily in large-scale applications with cooling loads in tens or hundreds of tons of refrigeration.

The scroll compressor, shown in Figure 8.10, though based on a century-old concept, is a recent development in rotary compressors. In it, an electric-motor-driven orbiting scroll meshes with a stationary scroll. Six crescent-shaped pockets formed between the involute scrolls trap, transport, and compress low-pressure refrigerant from the outside of the scrolls to the discharge passage at the scroll center. This process is more easily visualized by following the shaded pocket of refrigerant in Figure 8.11. Some of the advantages attributed to the scroll compressor are: continuous and smooth compression with 100% volumetric efficiency, no valves, physical separation of suction and discharge lines (which avoids the temperature cycling of reciprocating compressors), and higher compression efficiency than the best reciprocating units (ref. 10). Seasonal energy efficiency ratios (EERs averaged over a cooling season) in excess of 10 are readily attained with this technology. An animation of a scroll compressor may be seen on the internet at [www.copeland-corp.com](http://www.copeland-corp.com).

#### Suction and Subcooling Considerations

Let's examine two items of concern with respect to some vapor compression systems. In systems with reciprocating compressors, there is a danger that, due to changing cooling loads, that the liquid refrigerant in the evaporator may not be completely vaporized, causing slugs of liquid to

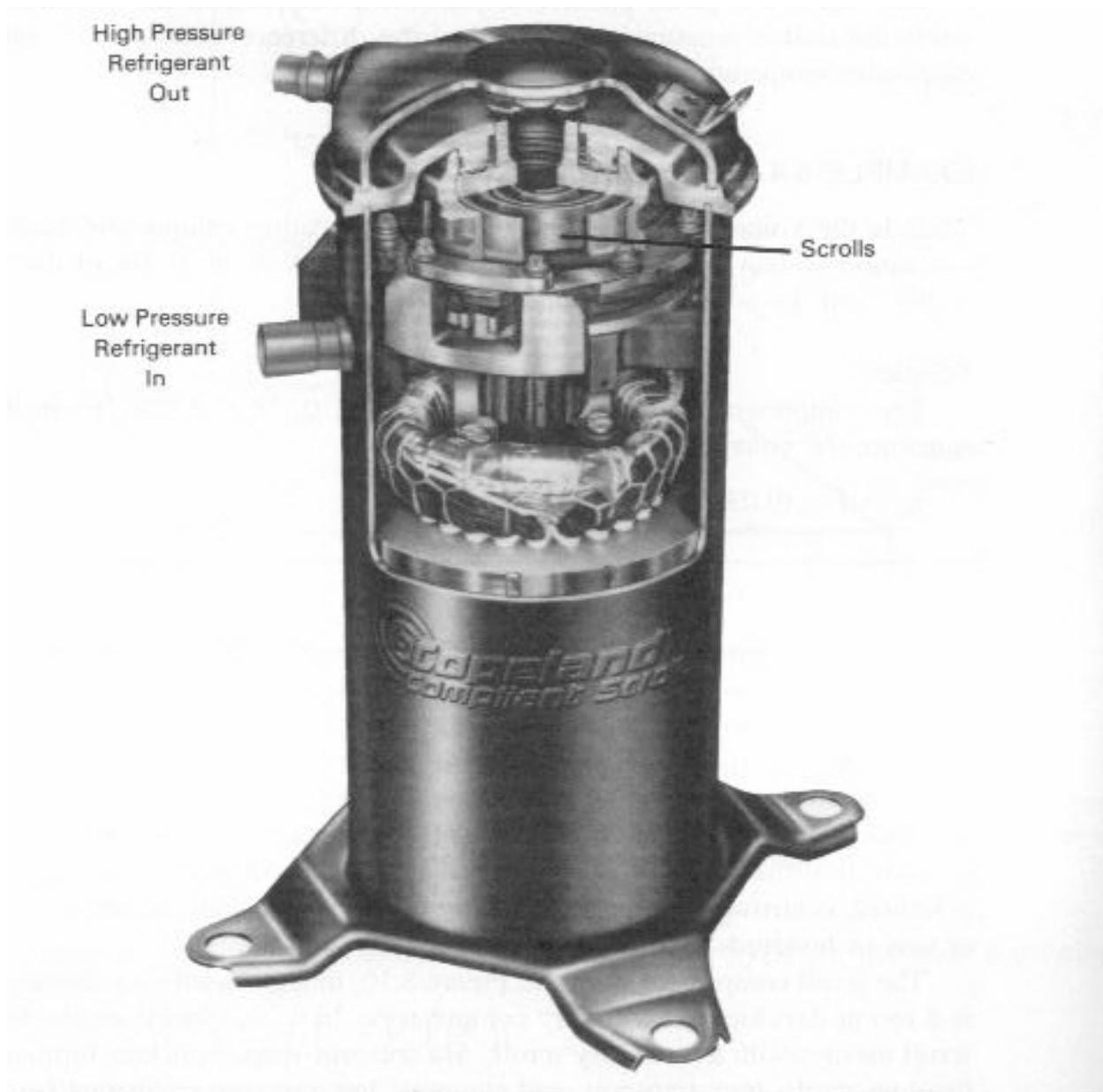

**FIGURE 8.10** Cutaway of a scroll-type compressor. (Courtesy of Copeland Corp., Sidney, Ohio.)

enter the compressor. Because liquids are essentially incompressible, positive-displacement compressors with fixed clearance volumes can be damaged when such "slugging" occurs.

The use of a thermostatic expansion valve (TEV) that responds to change in the degree of superheat in the suction line provides one solution to this problem. A bulb filled with refrigerant attached to the suction line, when heated by superheated vapor, transmits an increasing pressure signal to a diaphragm in the TEV, which adjusts the valve flow area and in turn changes the mass

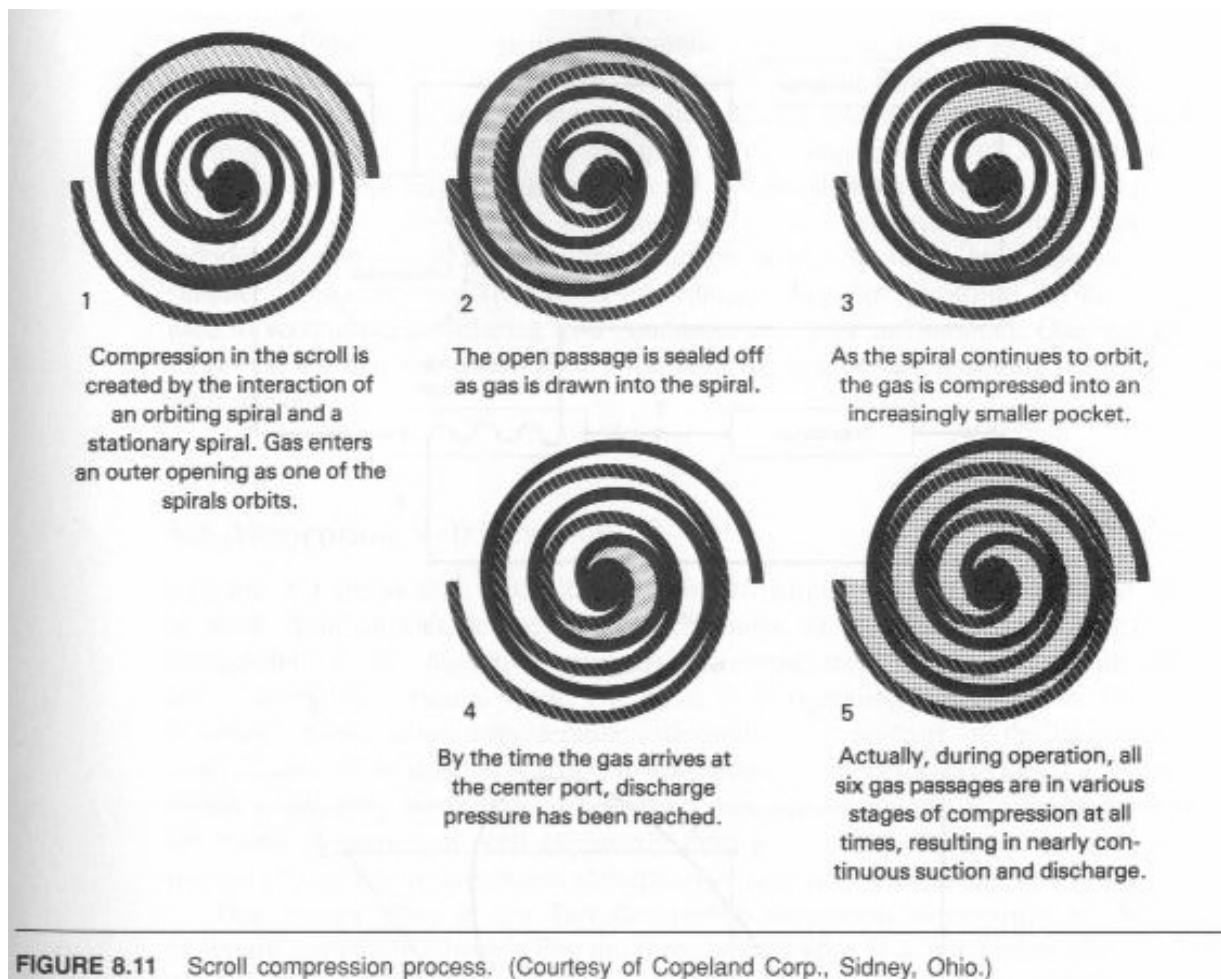

flow rate of refrigerant. This control is usually set to maintain a minimum of about five degrees of superheat to avoid liquid slugs entering the compressor inlet.

A second concern is the possibility of entry of vapor into the throttling valve if the refrigerant at the condenser exit is not completely condensed. Because vapor occupies much more space than liquid, the throttling valve will not function properly if vapor can enter from the condenser. One approach to dealing with this is to locate a liquid receiver downstream of the condenser to assure the availability of liquid to the expansion device.

Both of the above concerns may be dealt with simultaneously by the addition of a suction-line heat exchanger that superheats the evaporator discharge about five degrees, ensuring that only vapor enters the compressor. The heat exchanger that provides suction superheat from state 6 to state 1 in Figure 8.12 may be set up to receive heat from the subcooling of the condenser discharge from state 3 to state 4. This ensures the absence both of vapor entering the throttling valve and of liquid slugs entering the compressor. Note that the subcooling also tends to increase the refrigeration effect over that of the ideal cycle by decreasing the enthalpy entering the

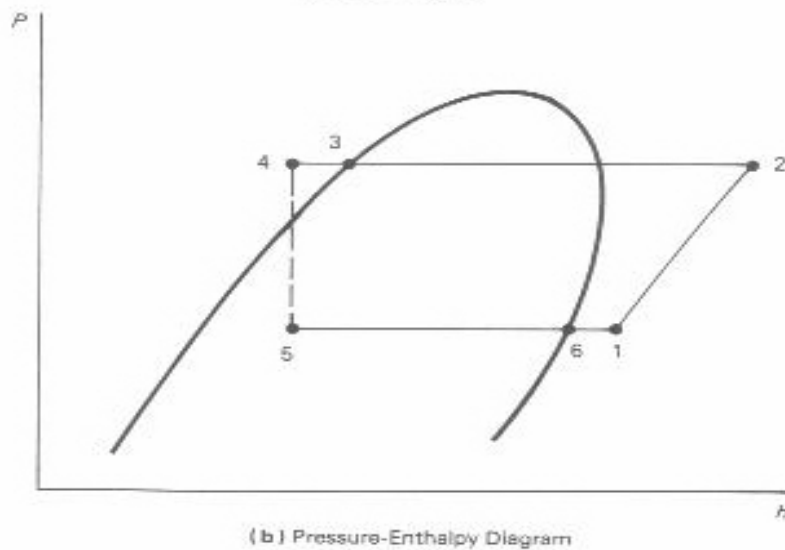
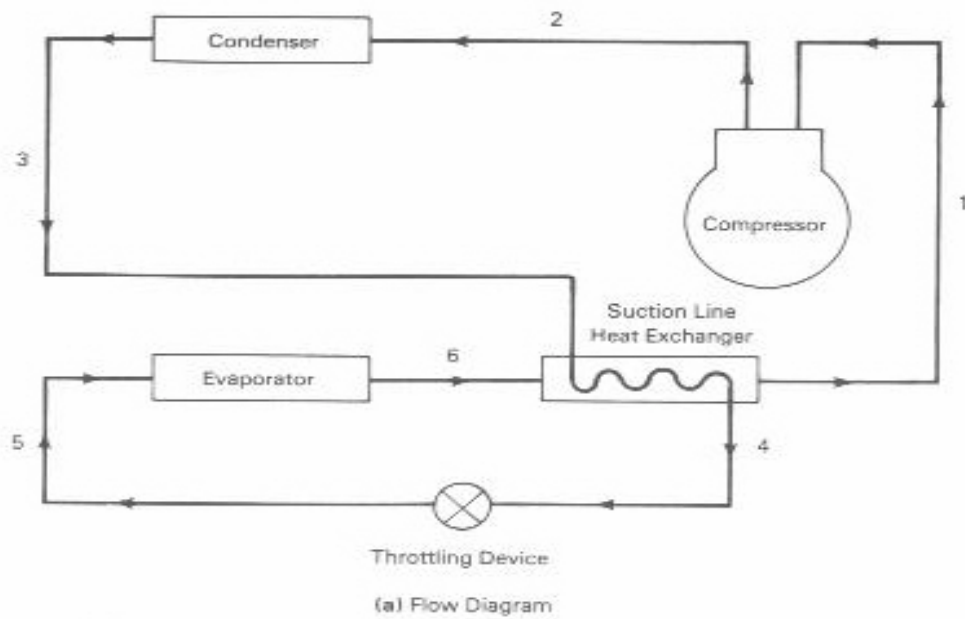

**FIGURE 8.12** Vapor compression refrigeration with suction superheat and condenser exit subcooling.

evaporator. This effect may be accomplished by running the compressor suction line next to the condenser discharge, allowing some thermal contact.

### Combining Heating and Cooling in a Single System

It is possible to combine both heating and cooling functions in a single system by providing heat exchangers that can operate as both evaporator and condenser and a control system that can reroute the flow of refrigerant when switching functions is required. Figure 8-13 presents a

schematic diagram for such a system, commonly called a heat pump (context usually determines whether the term “heat pump” refers to a device that heats only or that combines heating and cooling functions). The key component in a commercial heat pump is a *reversing valve*. With the valve shown in the figure, rotation through an angle of  $90^\circ$  reroutes the flow of refrigerant from the indoor coil to the outdoor coil, and vice versa. As a result of this change, the indoor coil that served as a condenser in the winter becomes an evaporator in the summer. The outdoor coil changes accordingly. Separate throttling devices may be used to accommodate differing load conditions in winter and summer. One-way check valves ensure that refrigerant flow is through the appropriate throttling device during each season.

### 8.3 Absorption Refrigeration

Example 8.3 shows that vapor compression refrigeration requires a significant supply of work from an electric motor or other source of mechanical power. Absorption refrigeration is an alternate approach to cooling that is largely thermally driven and requires little external work. This form of refrigeration is growing in importance as energy conservation considerations demand closer scrutiny of the disposition of heat rejection from thermal processes. Absorption refrigeration provides a constructive means of utilizing waste heat or heat from inexpensive sources at a temperature of a few hundred degrees, as well as directly from fossil fuels. The eventual abolition of the use of CFCs may also boost absorption refrigeration technology.

This system relies on the fact that certain refrigerant vapors may be dissolved in liquids called absorbents. For instance, water vapor is a *refrigerant* that tends to dissolve in liquid lithium bromide, an *absorbent*. Just as when they condense, vapors release heat when they go into solution. This heat must be removed from the system in order to maintain a constant temperature. Thus, cooling causes vapor to be absorbed in absorbents, just as cooling causes vapor to condense. On the other hand, heating tends to drive vapor out of solution just as it turns liquid to vapor. This solution phenomenon and the fact that pumping liquid requires a relatively small amount of work compared with that required to compress a gas are the secrets of absorption refrigeration.

Consider the schematic diagram in Figure 8.14, which shows a basic absorption refrigeration unit. The condenser / throttling valve / evaporator subsystem is essentially the same as in the vapor compression system diagram of Figure 8.2. The major difference is the replacement of the compressor with a different form of pressurization system. This system consists primarily of an *absorber* at the pressure of the evaporator, a vapor *generator* at the pressure of the condenser, and a solution pump. A second throttling valve maintains the pressure difference between the absorber and the generator.

The system operates as follows: Refrigerant vapor from the evaporator flows into the absorber, where it mixes with the absorbent. The mixture is cooled by heat transfer  $Q_A$  to air or water at the temperature of the environment, causing the vapor to go into solution. The refrigerant-absorbent solution flows to the solution pump where it is pressurized to the pressure level of the generator and condenser. Heat from an energy source,  $Q_G$ , then drives the vapor from the cold liquid solution. The vapor flows into the condenser while the heated liquid in the

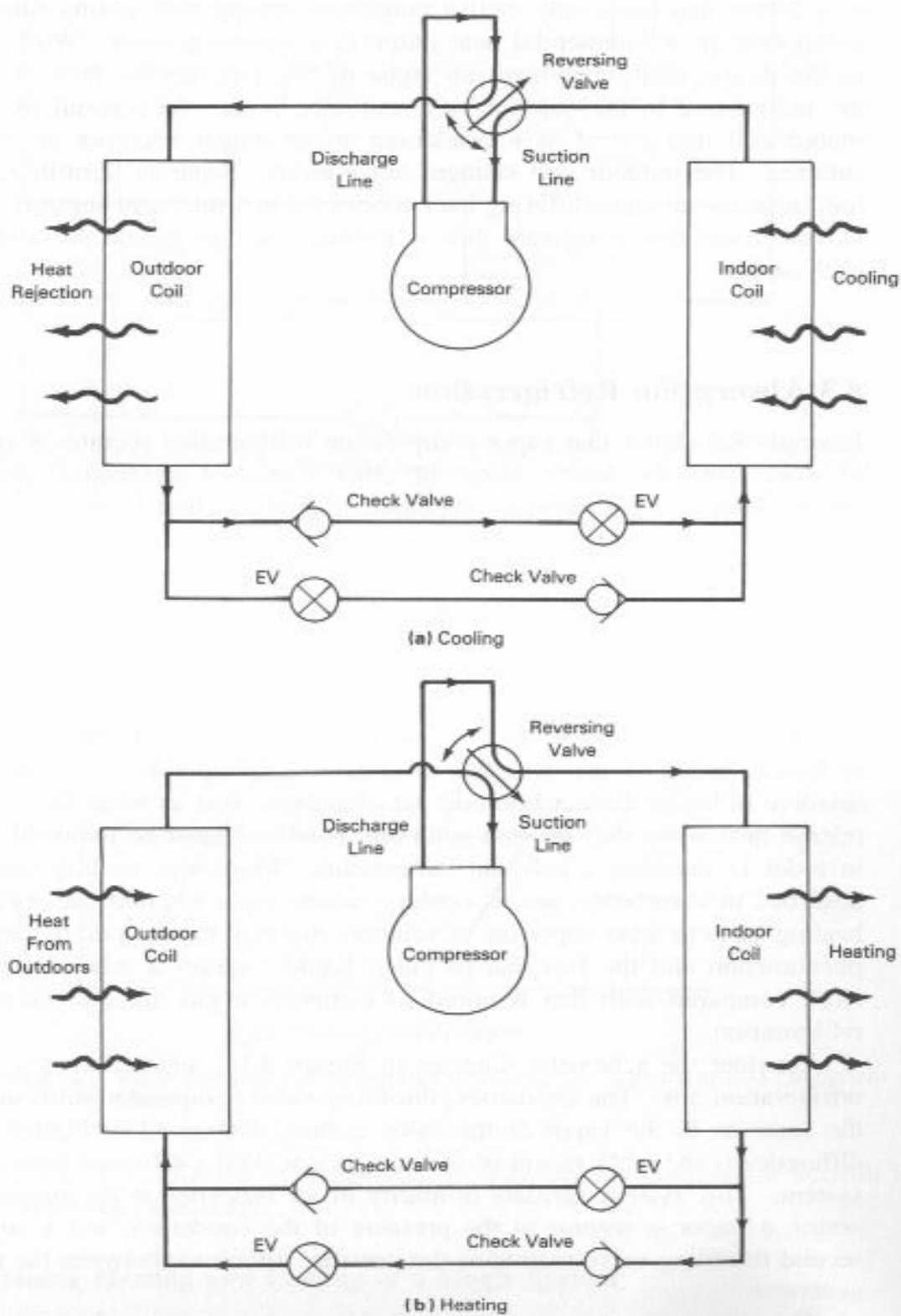

**FIGURE 8.13** Combined vapor compression system for summer cooling and winter heating. (a) Cooling. (b) Heating.

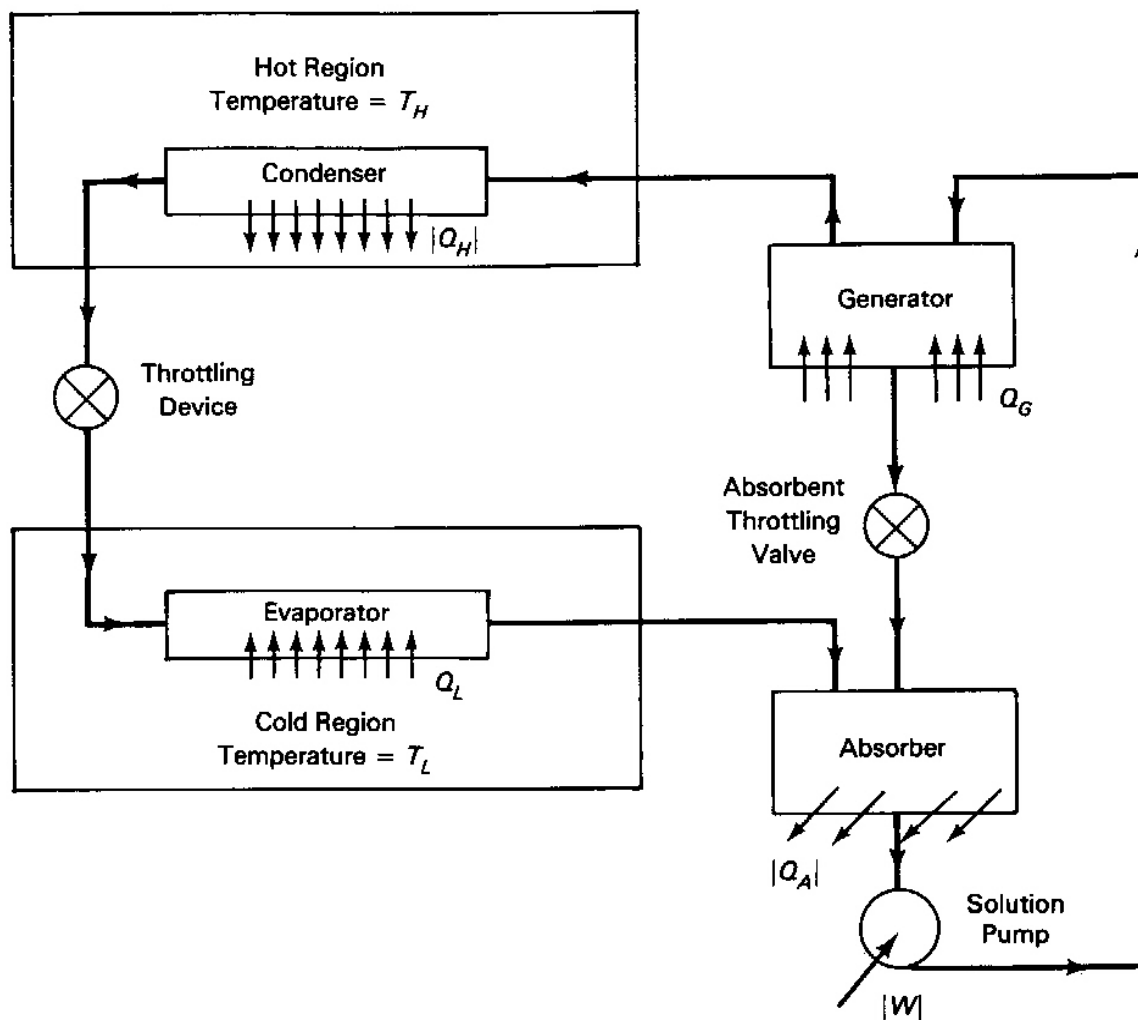

**FIGURE 8.14** Flow diagram of absorption refrigeration system.

generator passes back to the absorber through an *absorbent throttling valve*, thus completing the absorbent loop.

As in vapor compression systems, the condensed vapor from the condenser passes through the refrigerant throttling valve into the evaporator as a chilled refrigerant liquid-vapor mixture, where its vaporization creates the desired refrigeration effect. The evaporator vapor then flows back to the absorber to again go into solution and repeat the process. It should be noted that the only work required is a relatively small amount needed to operate the solution pump.

Thus the major energy requirement of an absorption refrigeration system is a transfer of heat  $Q_G$  from a source of moderate temperature, such as an engine combustion-gas exhaust, steam from a low-pressure boiler, or perhaps a heat transfer fluid from solar collectors. The coefficient of performance of an absorption system is therefore defined as the ratio of the refrigeration capacity to the rate of heat addition in the generator. This definition is fundamentally different

from that of the COP of a vapor compression system, because the energy source is in the form of heat rather than work. Therefore, it should not be surprising that absorption system COPs are much lower than those for vapor compression systems.

## 8.4 Comfort Air Conditioning

Professionals define *air conditioning* to include heating, humidifying, dehumidifying, circulating, cleaning, and those other operations involving air (in addition to cooling) that provide thermal comfort to people and effectiveness to processes. Studies of what constitutes thermal comfort to individuals have identified air temperature, humidity, ventilation, air movement, and air cleanliness as important control parameters. The systems needed to control all of these parameters are discussed in many references, including refs. 1 through 5. This chapter is concerned primarily with temperature and humidity control.

*Space cooling* and *space heating* are the primary functions that rely on vapor compression and absorption systems. In specifying systems to perform these functions, it is necessary to define the winter heating loads and summer cooling loads [Btu/hr | kW] for the space to be heated or cooled. Most HVAC (heating, ventilating, and air conditioning) professionals now have computer programs that assist in defining these loads.

The determination of *cooling loads* involves delimiting the space to be conditioned and defining the appropriate indoor and outdoor design conditions. For example, for some applications the *indoor design temperature and humidity* might be specified as 74°F and 50% relative humidity based on thermal comfort data and experience. For a given locale, the *ASHRAE Handbook* gives outdoor temperatures that are not exceeded during a given fraction of the summer season. For example, the *Handbook* indicates that the temperature in Tulsa, Oklahoma is usually not greater than 98°F during 97.5% of the four-month period from June to September. This, therefore, might be selected as a suitable summer *outdoor design temperature*.

A thermal cooling load analysis is performed with these design conditions and data on the structure and contents of the enclosure of the conditioned space for times when the load is expected to be greatest. The analysis involves heat transfer through walls, roofs, doors, and windows; and internal heat generation due to electrical devices, gas burning appliances, human occupants, and other sources. At such times, solar radiation is usually a strong influence. In most applications, additions of water vapor to air in the space must be considered also. The results of these calculations yield the design rates at which heat and moisture must be removed from the space. The air conditioning evaporator cooling capacity and the fan air circulation rate are then sized to provide for these near-extreme rates.

Cooling and heating loads at a given locale may be expected to vary approximately linearly with the deviation of the ambient temperature from a break-even temperature of about 65°F. At this outdoor temperature, no mechanical heating or cooling is required for thermal comfort. The break-even ambient temperature is usually below the indoor design temperature because of the necessity of a temperature difference for the rejection of heat through the walls required to balance the energy generation from sources in the space. Figure 8.15 shows typical performance behavior of vapor compression heating and cooling equipment superimposed on corresponding load curves. The equipment is necessarily oversized for mild temperatures. In the case of the heat



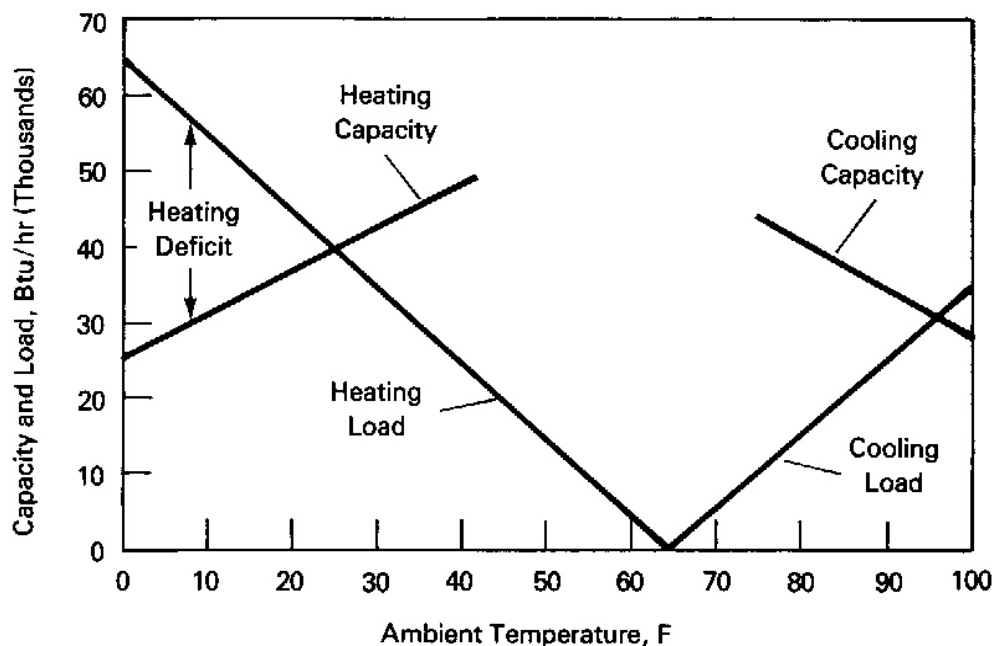

**FIGURE 8.15** Vapor-compression-system heating and cooling loads and system characteristics for a given installation.

pump, there is an ambient temperature at which the equipment capacity matches the heating load, the *balance point*. At lower temperatures the heat pump is unable to maintain the design indoor temperature, a heating deficit. This situation is usually handled by the use of electrical resistance heaters to supplement the heat pump output. The electric resistance heaters usually are switched on in banks as the ambient temperature decreases further below the break-even point. While the heat pump itself may be quite efficient, pure resistance heating with  $COP = 1.0$  results in degradation in overall efficiency and economy while the resistance heaters are in operation.

Operationally, for the frequent periods when capacity exceeds load, a thermostat is usually used to cycle the system on and off to provide for indoor comfort in a limited range of temperature around the indoor design value. More sophisticated systems resulting from advances in motor control, compressors, and fans may allow the system to operate at part load continuously, to avoid the discomfort and inefficiency of temperature cycling associated with simple thermostat operation.

The *dual-fuel heat pump*, a new approach to dealing with the weaknesses of the heat pump at low temperatures, has been proposed and studied by the Electric Power Research Institute, an equipment manufacturer, and several electric utilities (ref. 14). Instead of expensive and energy-wasteful resistance heating making up the heating deficit when ambient temperatures require operation below the heat pump balance point, a gas furnace built into the heat pump package comes online and economically satisfies the need for additional heat. The combined electric heat pump and gas unit operate together, unless the ambient temperature drops to still lower

temperature levels at which the cost of gas operation falls below the cost of electricity. Below this break-even point electric heat pump component shuts down and gas heat is used exclusively.

The break-even point may be adjusted when energy prices change. According to the reference, in regions where gas prices are high and electricity low, dual-fuel heat pump users will benefit from substantial reductions in operating costs and the utilities from increased off-peak sales in the winter months. However, the purchase price of the dual-fuel heat pump unit is expected to be higher than combined gas heating and electric cooling systems now used. This creates a marketing problem, because consumers often are more impressed by low purchase price than by low life-cycle costs resulting from low operating costs.

## 8.5 Moist Air and Air Conditioning System Design

### Psychrometrics

Although the mass fraction of water vapor in ambient air usually is numerically small, water vapor can have a significant influence on an individual's thermal comfort and on the design of air conditioning equipment. Most people can recall instances of discomfort associated with both excessively dry or moist air. Numerous industrial processes also require moisture control to maintain high standards of quality and productivity. The engineering fundamentals of dealing with moist air and the application of those fundamentals are treated here.

The study of the behavior of moist air is called *psychrometrics*. We will consider moist air as a two-component mixture of dry air and water vapor, and treat both components and the mixture as ideal gases in the context of the mixture theory discussed in Chapter 3.

### Humidity Ratio

Properties of moist air are commonly referred to the mass of dry air  $m_{da}$ , apart from the water vapor, contained in the air. For example, the *humidity ratio* is defined as the ratio of the mass of water vapor to the mass of dry air present in the moist air:

$$W = m_{wv}/m_{da} \quad [dl] \quad (8.8)$$

Together, the humidity ratio and the ambient temperature and pressure define the thermodynamic state of moist air, and therefore may be used to define other properties of moist air. Using the ideal gas law, the humidity ratio may be written as

$$\begin{aligned} W &= (p_{wv}V/R_{wv}T)/(p_{da}V/R_{da}T) = (p_{wv}/p_{da})(R_{da}/R_{wv}) \\ &= (p_{wv}/p_{da})(M_{wv}/M_{da}) \\ &= 0.622(p_{wv}/p_{da}) \quad [dl] \quad (8.9) \end{aligned}$$

where we have used the facts that the water vapor and dry air occupy the same space and therefore have the same volume, and that both components are in thermal equilibrium and therefore are at the same temperature. The ratio of gas constants in Equation (8.9), expressed in terms of the Universal Gas Constant, reduces to the inverse ratio of molecular weights  $M_{\text{wv}}/M_{\text{da}} = 18/28.9 = 0.622$ .

Thus the humidity ratio is equivalent to the ratio of partial pressures of water vapor and dry air. Going one step further, consider the total air pressure  $P$ , the pressure that we measure with a barometer, as the sum of partial pressures of dry air and water vapor according to Dalton's Law:

$$P = p_{\text{da}} + p_{\text{wv}} \quad [\text{lb}_f/\text{ft}^2 \mid \text{kPa}] \quad (8.10)$$

The humidity ratio then may be written as:

$$W = 0.622p_{\text{wv}}/(P - p_{\text{wv}}) \quad [\text{dl}] \quad (8.11)$$

Thus, for a given ambient pressure, the humidity ratio is determined by the existing partial pressure of water vapor. It is evident that because  $p_{\text{wv}} \ll P$ , the humidity ratio varies approximately linearly with the partial pressure of water vapor in the air. Humidity ratio is sometimes expressed in *grains* of water vapor per pound of dry air where there are 7000 grains per pound.

### Saturated Air

Moist air is said to be *saturated* when its humidity ratio is a maximum for the existing temperature and total pressure. The humidity ratio for saturated air may be determined using Equation (8.11) with the saturation pressure of water vapor obtained from saturated steam tables at the known temperature.

#### EXAMPLE 8.5

Determine the partial pressures of water vapor and dry air and the humidity ratio in saturated moist air for an ambient total pressure and temperature of 14.7 psia and 80°F, respectively.

#### Solution

From the saturated-steam tables at 80°F, the partial pressure of water vapor is 0.50683 psia. The partial pressure of the dry air component is then  $14.7 - 0.50683 = 14.2$  psia, and the humidity ratio is

$$W = 0.622(0.50683)/(14.7 - 0.50683) = 0.0222$$

Thus, at 80°F, the moist air may have no more than 0.0222 lb (or 155.4 grains) of moisture per pound of dry air.

---

While air at a given temperature and pressure can have no more water vapor than indicated by the humidity ratio for saturated air, the air can be drier. This is, of course, indicated by lower values of humidity ratio and also by relative humidity, as discussed next.

### Relative Humidity and Dew Point

An alternative parameter for indicating the moisture content of air is the *relative humidity*,  $\Phi$ . The relative humidity is defined as the ratio of the mole fraction of water vapor in unsaturated air to the mole fraction of water vapor in air that is saturated at the same temperature and total pressure:

$$\Phi = x_{\text{wv}}/x_{\text{wv,sat}} \quad [\text{dl}] \quad (8.12)$$

It has been shown in Chapter 3 that the mole fraction of a component of an ideal gas is the ratio of the partial pressure of that component to the total pressure of the gas. Thus the relative humidity may be written as

$$\Phi = (p_{\text{wv}}/P)/(p_{\text{wv}}/P)_{\text{sat}} = p_{\text{wv}}/p_{\text{wv,sat}} \quad [\text{dl}] \quad (8.13)$$

where the partial pressures are evaluated at the same temperature and total pressure. The relative humidity of the air may be related to the p-V diagram for its water component in Figure 8-16. The diagram shows two isotherms where  $T_1 = T_2 > T_3$ . Considering the top isotherm, the relative humidity of state 1 is the ratio of the pressure of water vapor at state 1 to that at the saturation vapor state at the same temperature, state 2. The figure shows that the maximum pressure of water vapor possible at a given temperature corresponds to the saturation pressure of water at that temperature. Thus increasing amounts of water vapor in air at a given ambient temperature are indicated by higher relative humidity, higher humidity ratio, higher water vapor partial pressure, and by vapor states closer to the saturated-vapor line for water. Thus the term "saturated air" implies that the water vapor in the air is a saturated vapor. These two uses of the term "saturated" should be distinguished to avoid confusion.

When a given mass of moist air cools slowly, the mass of water vapor in the air remains constant until the air becomes saturated. Thus the humidity ratio and the partial pressure of the water vapor are also fixed. This process is depicted by the line of constant pressure from 1 to 3 to 4 in Figure 8.16. Note that, once state 4 is reached, no further cooling can occur without condensation of water vapor. This condition, at which liquid water first appears, is known as the *dew point*. The formation of dew is a familiar early morning occurrence in which water vapor condenses, leaving drops of liquid on grass and other surfaces that are cooler than the surrounding air. The temperature at which water vapor begins to condense is therefore called the *dew point temperature*. It is evident from Figure 8.16 that as the air temperature at state 1 drops, approaching the dew point temperature, the relative humidity increases until it finally reaches 100% at state 4. Thus the dew point temperature for any moist air state may be obtained from the saturated-steam tables, if the partial pressure of the water vapor is known.

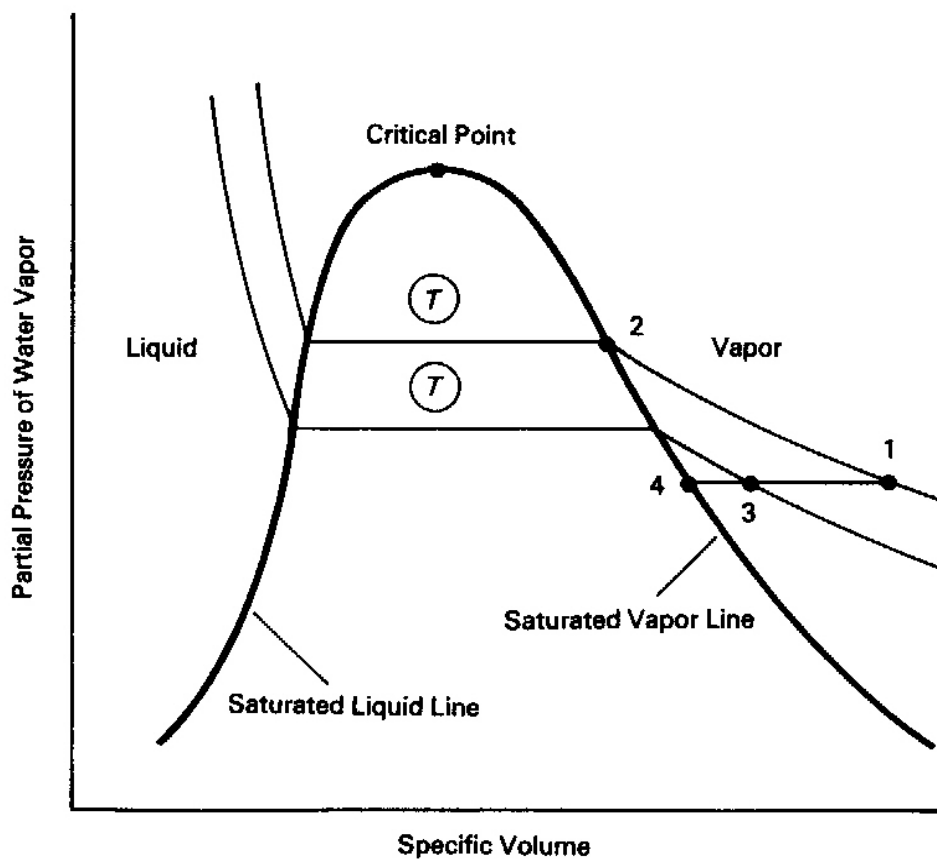

**FIGURE 8.16** Thermodynamic state of water vapor in moist air. State 4 is the dew point of states 1 and 3.

### EXAMPLE 8.6

In ambient moist air, the temperature and pressure are 70°F and 14.7 psia, respectively, and the relative humidity is 50%. What are the partial pressures of dry air and water vapor and the humidity ratio and dew point?

#### Solution

At 70°F, the steam tables give the saturation pressure of water as 0.36292 psia. This is the partial pressure of water vapor in saturated air. From Equation (8.13), the partial pressure of water vapor in the ambient air is then  $(0.5)(0.36292) = 0.181$ , and the corresponding partial pressure of dry air is  $14.7 - 0.181 = 14.52$  psia. Equation (8.11) then gives the humidity ratio:

$$W = 0.622(0.181)/14.52 = 0.0078 \text{ lb}$$

of water vapor per pound of dry air.

The tables for saturated steam give the dew point temperature of about 51°F for the vapor partial pressure of 0.181 psia.

### Enthalpy of Moist Air

Since any extensive property of a mixture of ideal gases is the sum of the corresponding properties of the components, the enthalpy of moist air is the sum of the enthalpies of dry air and water vapor. Hence

$$H = H_{da} + H_{wv} = m_{da}h_{da} + m_{wv}h_{wv} \quad [\text{Btu} \mid \text{kJ}]$$

where the mass of the mixture is  $m_{da} + m_{wv}$ . In order to define an enthalpy per unit mass for the mixture, it must be decided which mass to select as a reference for the specific enthalpy of the mixture. As with the humidity ratio, the usual choice in psychrometrics is the mass of dry air. Thus the specific enthalpy of moist air is given by  $h = H/m_{da}$ :

$$h = h_{da} + (m_{wv}/m_{da})h_{wv} = h_{da} + Wh_{wv} \quad [\text{Btu/lb}_m \mid \text{kJ/kg}] \quad (8.14)$$

Because the temperature range of most air conditioning operations is limited, it is usually satisfactory to use constant heat capacities in dealing with enthalpy calculations. Selecting the reference temperatures for enthalpy as 0° on both scales, the enthalpies of the dry air, expressed in terms of Fahrenheit and Celsius temperatures, may be written as

$$h_{da} = c_{pda}T [\text{F}] = 0.24T [\text{F}] \quad [\text{Btu/lb}_m]$$

and

$$h_{da} = c_{pda}T [\text{C}] = 1.004T [\text{C}] \quad [\text{kJ/kg}]$$

The enthalpy of water vapor is the sum of the sensible and latent enthalpies:

$$\begin{aligned} h_{wv} &= h_s + h_{fg} = c_{pwv}T + h_{fg} \\ &= 0.446T [\text{F}] + 1061.2 \quad [\text{Btu/lb}_m] \end{aligned} \quad (8.15a)$$

$$= 1.867 T [\text{C}] + 2501.3 \quad [\text{kJ/kg}] \quad (8.15b)$$

### EXAMPLE 8.7

Compare the enthalpy of water vapor from Equation (8.15a) with that from the steam tables for 32°, 100°, 150°, and 200°F.

**Solution**

For 32°F, the enthalpy is

$$h_{wv} = 0.446(32) + 1061.2 = 1075.47 \text{ Btu/lb}_m$$

This compares with 1075.5 Btu/lb<sub>m</sub> from the steam tables. The comparison for other temperatures is as follows:

Temperature, °F	Enthalpy, Btu/lb <sub>m</sub> – Equation (8.15a)	Enthalpy, Btu/lb <sub>m</sub> – Steam Tables
32	1075.47	1075.5
100	1105.8	1105.1
150	1128.1	1126.1
200	1150.4	1146

Thus the approximation is quite accurate in and beyond the air conditioning range, but it decreases in accuracy as temperature increases.

Combining the above relations, we may then write the enthalpies of moist air as

$$\begin{aligned} h &= c_{pda}T [F] + W\{c_{pwv}T [F] + h_{fg}\} \\ &= 0.24T [F] + W\{0.446T [F] + 1061.2\} \quad [\text{Btu/lb}_m] \end{aligned} \quad (8.16a)$$

$$\begin{aligned} h &= c_{pda}T [C] + W\{c_{pwv}T [C] + h_{fg}\} \\ &= 1.004T [C] + W\{1.867T [C] + 2501.3\} \quad [\text{kJ/kg}] \end{aligned} \quad (8.16b)$$

**Adiabatic Saturation**

Consider a steady-flow process in which air flows through a liquid water spray in a duct where the air entrains moisture until it becomes saturated. If the duct is insulated so that the flow is adiabatic, and the water spray and the moist air leaving the duct are at the same temperature, the process is referred to as an *adiabatic saturation* process. It is shown shortly that measurement of the temperature and pressure of the air entering the duct and the final moist air temperature, called the *adiabatic saturation temperature*, determines the state of the moist air entering the duct. Thus two temperature measurements and a pressure measurement are sufficient to determine the state of moist air.

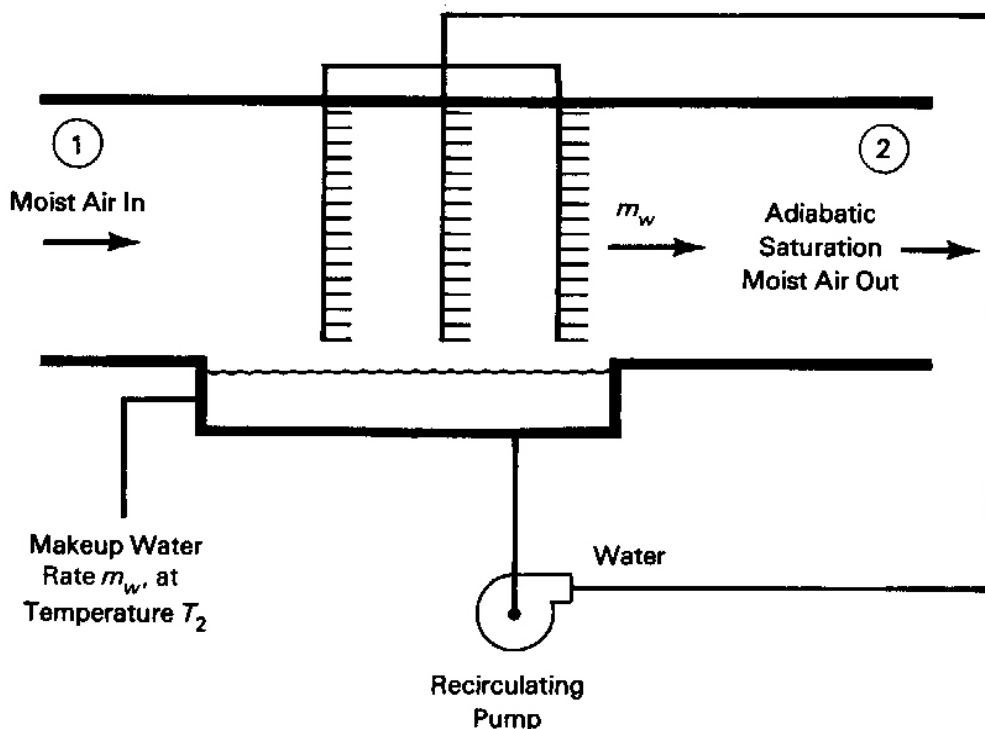

**FIGURE 8.17** Schematic of an adiabatic saturation device.

Figure 8.17 shows a schematic of an adiabatic saturation device in which liquid water at the adiabatic saturation temperature  $T_2$  is evaporated at a rate  $m_w$  into a moist air stream flowing at a rate of  $m_{da}(1 + W)$  through the duct. Thus conservation of mass applied separately to both dry air and water components yields

$$m_{da2} = m_{da1} = m_{da} \quad [\text{lb}_m/\text{s} \mid \text{kg}/\text{s}]$$

$$m_{da}W_1 + m_w = m_{da}W_2 \quad [\text{lb}_m/\text{s} \mid \text{kg}/\text{s}]$$

Combining these equations, we find that the ratio of the mass flow rate of entrained water or makeup water to the mass of dry air is

$$m_w/m_{da} = (W_2 - W_1) \quad [\text{dl}] \quad (8.17)$$

The steady flow form of the First Law yields

$$m_{da1}(h_{da1} + W_1h_{wv1}) + m_w h_f = m_{da2}(h_{da2} + W_2h_{wv2})$$

where  $h_f$  is the enthalpy of the saturated liquid at  $T_2$ . Substituting Equation (8.17) into this



equation yields

$$(h_{da1} + W_1 h_{wv1}) + (W_2 - W_1) h_f = (h_{da2} + W_2 h_{wv2})$$

or

$$W_1(h_{wv1} - h_f) = c_{pda}(T_2 - T_1) + W_2(h_{wv2} - h_f) \quad [\text{Btu/lb}_m \mid \text{kJ/kg}]$$

or

$$W_1 = \{c_{pda}(T_2 - T_1) + W_2(h_{wv2} - h_f)\} / (h_{wv1} - h_f) \quad [\text{dl}] \quad (8.18)$$

Given the initial temperature  $T_1$ ,  $h_{wv1}$  is determined from Equation (8.15). If  $T_2$  and  $P_1 = P_2$  are also measured, the saturation partial pressure, the humidity ratio  $W_2$ , the vapor enthalpy  $h_{wv2}$ , and the liquid-water enthalpy  $h_f = h_f(T_2)$  may also be determined using the steam tables and Equations (8.11) and (8.15). Equation (8.18) may then be solved for the upstream (ambient) humidity ratio. The following example demonstrates the use of the adiabatic saturation concept in the determination of the ambient moist air state.

### EXAMPLE 8.8

Ambient air at 14.7 psia and 70°F drops to 56°F in passing through an adiabatic saturator. What is the ambient humidity ratio and the relative humidity?

**Solution**

Saturated air at 56°F yields a partial pressure of 0.22183 psia, a humidity ratio

$$W_2 = 0.622(0.22183)/(14.7 - 0.22183) = 0.00953$$

a water-vapor enthalpy  $h_{wv2} = 1086 \text{ Btu/lb}_m$ , and makeup-water enthalpy  $h_f = 24.059 \text{ Btu/lb}_m$ .

At the inlet where  $T_1 = 70^\circ\text{F}$ , the water-vapor enthalpy  $h_{wv1} = 1092.1 \text{ Btu/lb}_m$ . Thus, from Equation (8.18)

$W_1 = [0.24(56 - 70) + 0.00953(1086 - 24.059)] / (1092.1 - 24.059) = 0.00633 \text{ lb}$   
of water vapor per pound of dry air.

Solving Equation (8.11) for the partial pressure of water vapor gives

$$p_{wv1} = (W_1)(P)/(0.622 + W_1) = (0.00633)(14.7)/(0.622 + 0.00633) = 0.1481 \text{ psia}$$

Because the saturation partial pressure of water vapor at 70°F is  $p_{wv1, \text{sat}} = 0.36292 \text{ psia}$ , the relative humidity at state 1 is

$$\Phi = 0.1481/0.36292 = 0.408, \quad \text{or} \quad 40.8\%.$$

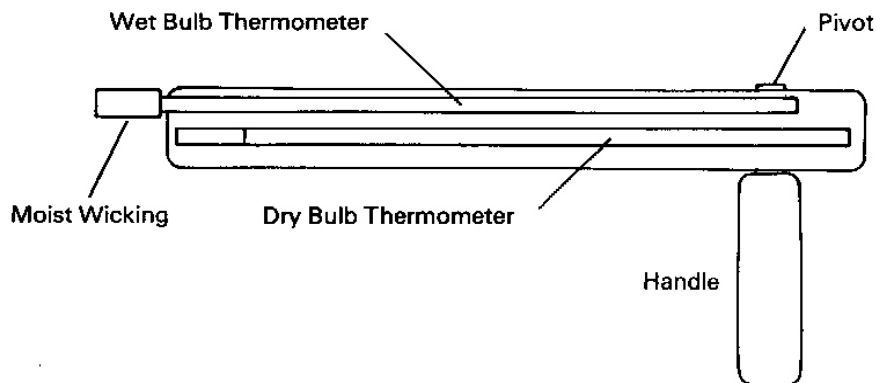

**FIGURE 8.18** Sling psychrometer.

We may summarize the adiabatic saturation process as one in which liquid water evaporates into the air flow, increasing the mass of water vapor in the air and therefore increasing the humidity ratio and, according to Equation (8.11), increasing the partial pressure of the vapor also. Because the flow is adiabatic, the heat of vaporization for the water must come from the flow of moist air, decreasing the air temperature. The increase in vapor partial pressure implies that the air dew point temperature increases as the flow passes through the saturator, ending at the adiabatic saturation temperature.

In order to distinguish among the various temperatures dealt with in psychrometrics, the temperature of moist ambient air, as measured by a mercury-in-glass thermometer, a thermocouple, or an equivalent device, is known as the *dry bulb temperature*.

The *sling psychrometer*, a more convenient and inexpensive device for determining moist air states than the adiabatic saturator, uses two mercury-in-glass thermometers rigidly attached to a frame with a pivoted handle as shown in Figure (8.18). The bulb of one thermometer, called the *wet bulb*, is wrapped in moistened wicking, and the other is left bare to measure the dry-bulb temperature. In operation, the user twirls the psychrometer for a minute or two until the readings of the thermometers stabilize. Evaporation of water from the wicking cools the wet bulb in proportion to the dryness of the ambient air. The temperature difference between the bulbs is commonly called the *wet-bulb depression*. Tables are sometimes provided to give relative humidity in terms of wet-bulb depression, but a psychrometric chart may be conveniently used to identify the moist air properties, as discussed in the next section.

The wet-bulb temperature, as an approximation to the adiabatic saturation temperature, together with the dry-bulb temperature and barometric pressure, determines the state of the moist ambient air. While the wet-bulb process differs fundamentally from the adiabatic saturation process, in practice it provides a reliable approximation to the wet-bulb temperature. Thus the adiabatic saturation temperature is sometimes referred to as the thermodynamic wet-bulb temperature.

Devices that give direct readings of humidity are called *hygrometers*. These devices are usually more complicated and expensive and less reliable than the psychrometer. They

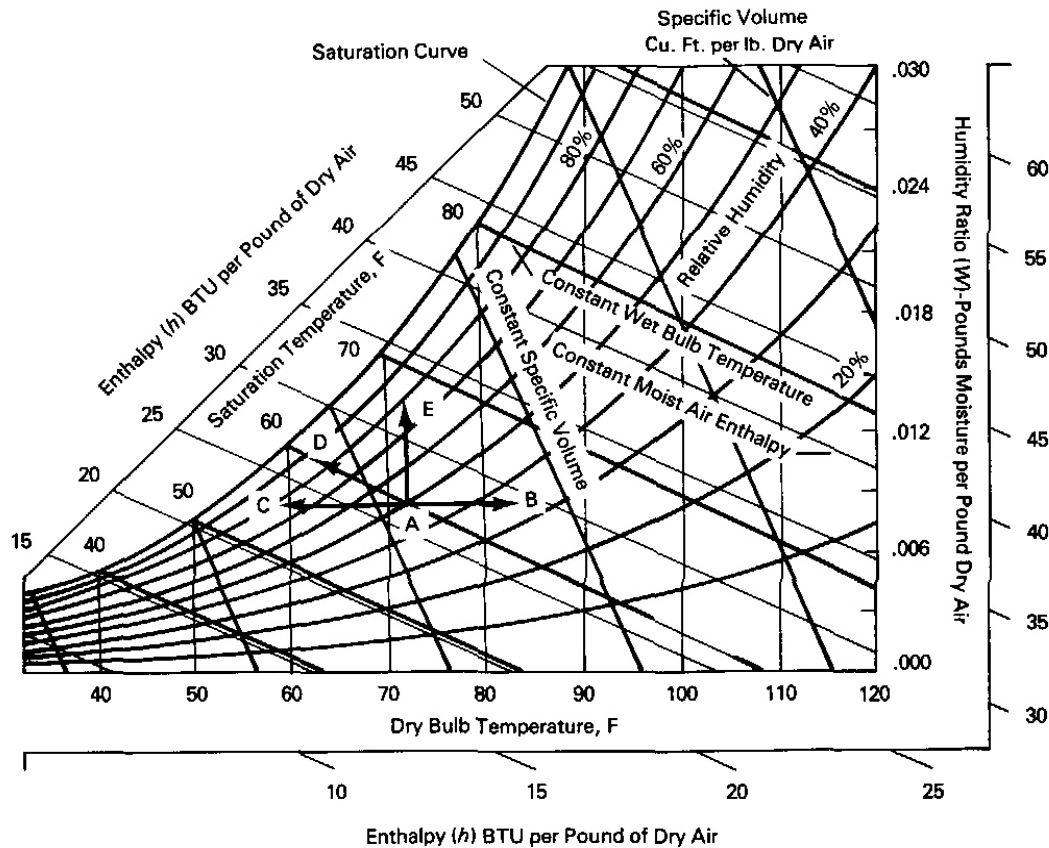

**FIGURE 8.19** Skeleton psychrometric chart showing basic psychrometric processes.

commonly make use of properties of materials that are influenced by the presence of water vapor, such as elongation and shrinkage. Human hair, paper, and nylon are examples of such materials. More information on hygrometers is available in reference 2.

### The Psychrometric Chart

The properties and processes described above are conveniently related on a graph commonly known as a *psychrometric chart*. Although close examination of the skeleton chart of Figure 8.19 and the detailed chart in the Appendix shows that it is not quite a rectangular coordinate plot, for most purposes it may be thought of as such, with humidity ratio as ordinate and dry bulb temperature as abscissa. A psychrometric chart is constructed for a specified value of barometric pressure. Thus charts for different barometric pressures should be selected for analyses for high altitudes, such as at Denver's, where atmospheric pressure is low, and those near sea level, such as Houston's, where it is normally high.

While most psychrometric charts are based on the precise methods of reference 7, it is instructive to consider how a chart could be constructed based on the ideal gas theory discussed earlier and on the steam tables. The curve labeled "saturation" on the psychrometric chart corresponds to states of air containing saturated water vapor at each dry-bulb temperature. For each value of dry-bulb temperature, the saturation partial pressure obtained from the steam tables determines the saturation humidity ratio for a specified atmospheric pressure [Equation (8.11)]. Thus the saturation curve relates the dew point temperature (measured on the abscissa) to the humidity ratio and to the corresponding partial pressure of water vapor. The saturation line also defines the conditions for 100% relative humidity.

For a given dry-bulb temperature, Equation (8.13) shows that the vapor partial pressure varies linearly with  $\Phi$ :

$$p_{\text{wv}} = \Phi \cdot p_{\text{wv, sat}}$$

For a given value of  $\Phi$ , the humidity ratio can then be established using Equation (8.11). Hence the value of  $\Phi$  and the dry-bulb temperature determine the value of the ordinate  $W$ . Thus a line of constant relative humidity  $\Phi$  lies between the horizontal axis ( $p_{\text{wv}} = 0$  or  $W = 0$ ) and the chart saturation curve at a vertical position in proportion of the magnitude of  $\Phi$ .

Lines of constant volume of moist air per unit mass of dry air may be approximated using the ideal gas law applied to the dry air component:

$$v = R_{\text{da}} T / p_{\text{da}} = R_{\text{da}} T / (P - p_{\text{wv}}) \quad [\text{ft}^3/\text{lb}_m \mid \text{m}^3/\text{kg}] \quad (8.19)$$

where  $R_{\text{da}}$  is the gas constant for dry air. Because dry air and water vapor occupy the same volume independently, the specific volume of moist air based on unit mass of dry air is the same as that for dry air. For zero humidity ratio, the air is dry and  $p_{\text{wv}} = 0$ . Then the dry-bulb temperature and ambient pressure alone determine the specific volume for each point on the horizontal axis of the chart. As the humidity ratio and hence the vapor partial pressure increase at constant ambient pressure, Equation (8.19) shows that the dry-bulb temperature must decrease to hold  $v$  constant. This establishes the negative slope of constant-specific-volume lines on the psychrometric chart. It is also easily seen from Equation (8.19) that, for dry air along the horizontal axis, lines of higher specific volume are located at higher dry-bulb temperatures. The same conclusion follows for any constant value of humidity ratio.

Similar arguments may be used, together with Equation (8.14), to explain the slope and variation of lines of constant enthalpy with dry-bulb temperature on the psychrometric chart.

### Processes on the Psychrometric Chart

Consider point A on the psychrometric chart in Figure 8.19. The processes of heating and cooling to points B and C, respectively, are called *sensible heating* and *sensible cooling*. The term "sensible" implies change in dry-bulb temperature without change in moisture content. These processes occur at constant humidity ratio and thus at constant dew point temperature,  $T_{\text{dp}}$ .

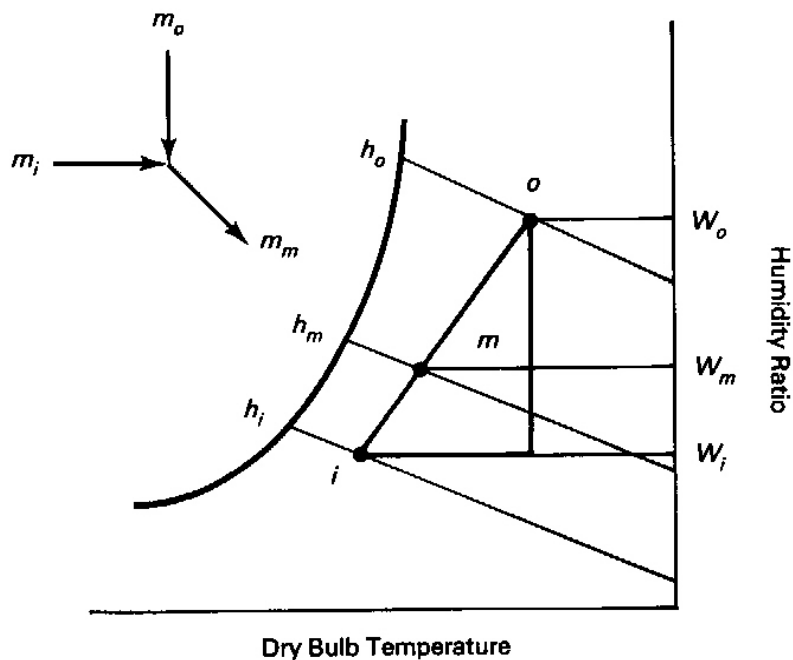

**FIGURE 8.20** Mixing of two moist air streams on a psychrometric chart.

Next consider processes in which either moistening or drying of air takes place. An example of a *humidification*, or air-moistening, process already considered is the adiabatic saturation process. It is represented by movement along a line of constant wet-bulb temperature toward the saturation curve, such as the line AD on the figure.

A *pure humidification* process is one in which the humidity ratio increases at constant dry-bulb temperature. The line AE in Figure 8.19 represents this process. The process requires the addition of water vapor to the air, with a consequent energy increase corresponding to the heat of vaporization of water,  $(W_E - W_A)h_{fg}$ . The enthalpy increase between points A and E indicated by the chart is equal to this quantity because no sensible heating has occurred. The process is said to involve *latent heat* as opposed to sensible heat. Thus an isothermal change in humidity ratio represents a *latent heat load* associated with the moist air mass and the equipment dealing with it. The reverse process EA may be thought of as pure *dehumidification*. The modifier "pure" is meant to suggest that there are other, more common and easily executed, humidification and dehumidification processes in which dry bulb temperature change is involved. Examples are air washer processes like the adiabatic saturator and desiccant drying (to be discussed later).

Let us now consider the steady-flow, *adiabatic mixing* of two moist air streams at states i and o to form a single stream at state m as shown in Figure 8.20. Conservation of mass of dry air and water vapor yields

$$m_i + m_o = m_m \quad [\text{lb}_m/\text{s} \mid \text{kg/s}] \quad (8.20)$$

and

$$m_i W_i + m_o W_o = m_m W_m$$

Dividing through by the mixture mass flow rate, the latter equation becomes

$$W_m = (m_i/m_m)W_i + (m_o/m_m)W_o \quad [\text{dl}] \quad (8.21)$$

Thus the mixture humidity ratio is the mass-weighted average of the humidity ratios of the two streams. Applying conservation of energy to the adiabatic mixing process, we obtain

$$0 = m_m h_m - m_i h_i - m_o h_o$$

which may be written as

$$h_m = (m_i/m_m)h_i + (m_o/m_m)h_o \quad [\text{Btu/lb}_m \mid \text{kJ/kg}] \quad (8.22)$$

This equation is of the same form as Equation (8.21).

Thus, given the flow rates and properties of the two streams, the mass flow of the mixture is the sum of the masses of the two inflowing streams and the humidity ratio and enthalpy of the mixture may be obtained by calculating the weighted means of the humidity ratios and enthalpies from Equations (8.21) and (8.22).

A graphical solution for the mixture state can be easily obtained on the psychrometric chart. For fixed states *i* and *o*, Equations (8.21) to (8.22) depend on a single parameter,  $m_i/m_m$ , or

$$m_o/m_m = m_o/(m_o + m_i) = 1 - m_i/m_m$$

Rearranging Equations (8.21) and (8.22) they become

$$(W_m - W_i)/(W_o - W_i) = m_o/m_m \quad [\text{dl}] \quad (8.23a)$$

$$(h_m - h_i)/(h_o - h_i) = m_o/m_m \quad [\text{dl}] \quad (8.23b)$$

Eliminating the mass ratio between these equations defines a linear relation between the mixture humidity ratio  $W_m$  and enthalpy  $h_m$ :

$$W_m = W_i + (h_m - h_i)(W_o - W_i)/(h_o - h_i) \quad [\text{dl}]$$

as shown in Figure 8.20. The explicit linear dependence of  $W_m$  and  $h_m$  on  $m_o/m_m$  is shown by rearranging Equations (8.23a and b) into

$$W_m = W_i + (W_o - W_i)(m_o/m_m) \quad [\text{dl}] \quad (8.23c)$$

$$h_m = h_i + (h_o - h_i)(m_o/m_m) \quad [\text{Btu/lb}_m \mid \text{kJ/kg}] \quad (8.23d)$$

When the flow rates and properties of states i and o are known, the latter two equations define the mixture state.

These equations are the basis for a graphical method to determine the mixture state, as suggested earlier. A straight line connecting states i and o is drawn on the psychrometric chart, and the mass fraction  $m_o/m_m$  in Equations (8.23) is laid out as the fraction of the distance between i and o measured from state i. The resulting point defines the properties of the mixture state.

### EXAMPLE 8.9

Ten  $\text{lb}_m/\text{sec}$  of outdoor air at  $100^\circ\text{F}$  dry-bulb and 60% relative humidity at sea level is mixed with 20  $\text{lb}_m/\text{sec}$  of indoor air at  $75^\circ\text{F}$  dry-bulb and 40% relative humidity. Determine the moist air properties of the mixture.

#### Solution

From the psychrometric chart for the outdoor air state:  $h_o = 51.8 \text{ Btu}/\text{lb}_m$  and  $W_o = 0.0252 \text{ lb}_m$  water vapor per  $\text{lb}_m$  dry air. For indoor air:  $h_i = 26 \text{ Btu}/\text{lb}_m$  and  $W_i = 0.0074 \text{ lb}_m$  of water vapor per  $\text{lb}_m$  dry air. From Equations (8.20) and (8.21), the humidity ratio is then:

$$W_m = (10/30)(0.0252) + (20/30)(.0074) = 0.01333 \text{ lb}_m$$

water vapor per  $\text{lb}_m$  dry air, and the enthalpy is

$$h_m = (10/30)(51.8) + (20/30)(26) = 34.6 \text{ Btu}/\text{lb}_m$$

Other mixture properties from the psychrometric chart are then  $83.4^\circ\text{F}$  dry-bulb,  $65^\circ\text{F}$  dew point, and  $70.8^\circ\text{F}$  wet-bulb temperatures, 54% relative humidity, and  $13.97 \text{ ft}^3/\text{lb}_m$  specific volume.

## Psychrometric Analysis of Space Cooling

An important application of psychrometrics is in the analysis and design of air conditioning systems. In comfort cooling, a control volume (see Figure 8.21), usually referred to as a space or zone, is identified as a room or group of rooms that have common thermal conditions and are to be put under the control of a single thermostat or control. Those conditions are usually defined by the atmospheric pressure, dry-bulb temperature, a humidity parameter such as humidity ratio, and specified sensible and latent cooling loads,  $q_s$  and  $q_L$ . The design sensible and latent loads are defined based on the characteristics of the boundaries of the zone and on its external and desired internal environments, as discussed earlier. The *sensible heat factor*,

$$\text{SHF} = q_s/q_t = q_s/(q_s + q_L) \quad [\text{dl}] \quad (8.24)$$

defines the fraction of the total load  $q_t$  due to the sensible load. The sensible heat factor, SHF,

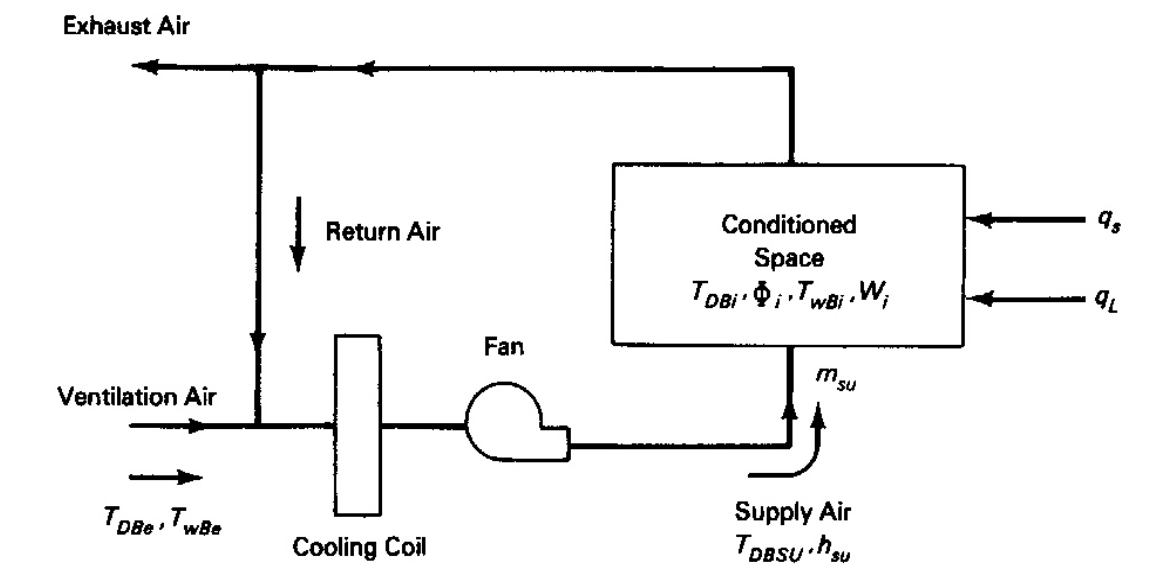

**FIGURE 8.21** Schematic for space cooling and dehumidification.

together with the sensible load, is frequently used in defining the conditions for cooling a zone.

Consider the conditioned space in Figure 8.21 as having specified latent and sensible loads. It is desired to hold the dry-bulb temperature of the indoor space at  $T_{DBi}$  and relative humidity,  $\Phi_i$  (the wet-bulb temperature  $T_{wBi}$  or humidity ratio  $W_i$  could be used instead). The design outdoor environment is represented by design dry-bulb and wet-bulb temperatures,  $T_{DBe}$  and  $T_{wBe}$ , respectively, as shown on the psychrometric chart in Figure 8.22. A system is to be designed to supply cool, dry air to offset the sensible and latent loads imposed on the zone. The system is represented by a frictionless adiabatic ducting system that supplies conditioned air, the *supply air* (state su on the chart), to replace an equal mass of room air at the space conditions (state i). Part of the air leaving the zone is exhausted to the environment; and the balance, the *return air*, is mixed with fresh outdoor *ventilation air* (state e). The mixture of return air and ventilation air (state m) is cooled and dehumidified by a cooling coil and circulated back to the space by a supply-air fan. It is desired to determine suitable values for supply-air temperature, coil cooling rate, and fan volume flow rate.

Assuming that air leaves the space at temperature  $T_{DBi}$ , the steady-flow form of the First Law applied to the space yields

$$q_t = q_s + q_L = m_{su}(h_i - h_{su}) \quad [\text{Btu/hr} \mid \text{kW}] \quad (8.25)$$

The enthalpy difference in this equation can be written as

$$h_i - h_{su} = h_i - h_3 + h_3 - h_{su} \quad [\text{Btu/lb}_m \mid \text{kJ/kg}]$$



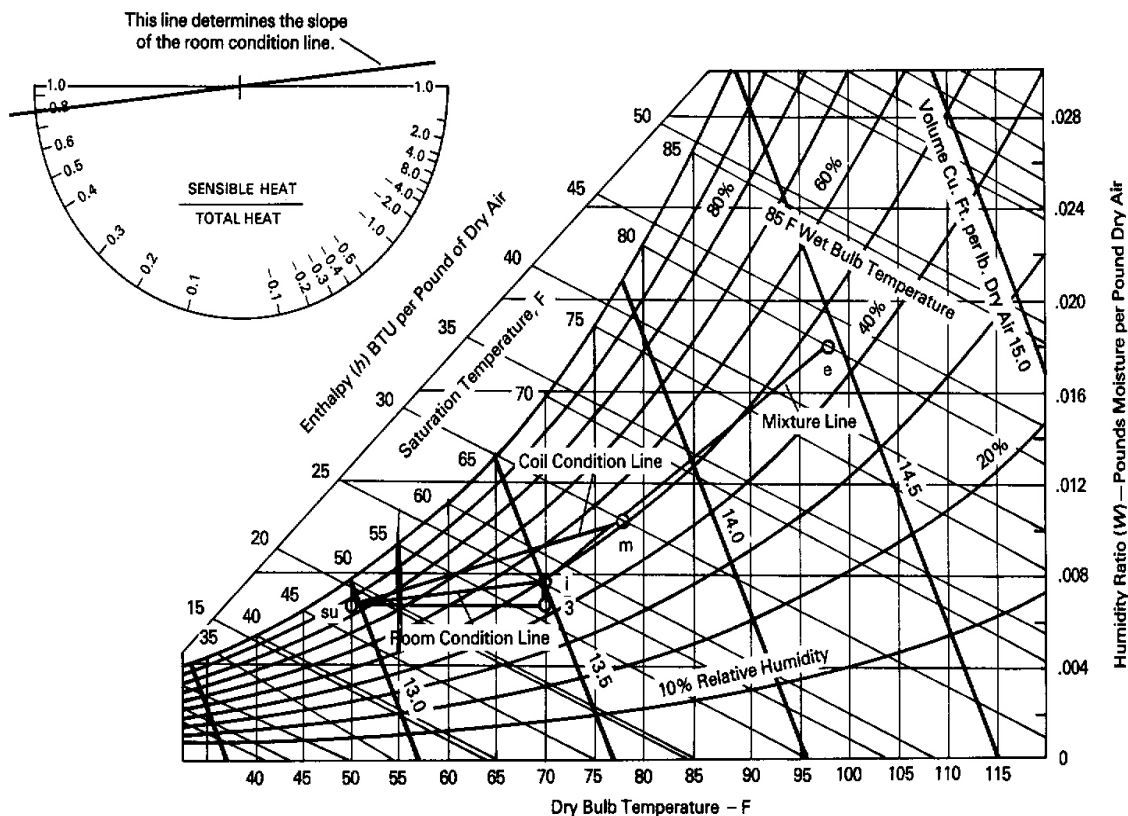

FIGURE 8.22 Psychrometric chart applied to Example 8.10.

This decomposition is seen graphically in the psychrometric chart in terms of the triangle  $i \rightarrow su \rightarrow 3$ . Thus

$$q_t = m_{su}(h_i - h_3 + h_3 - h_{su}) \quad [\text{Btu/hr} \mid \text{kW}] \quad (8.26)$$

Because the sensible heat, reflecting the supply-air dry-bulb temperature rise, may be written as

$$q_s = m_{su}(h_3 - h_{su}) \quad [\text{Btu/hr} \mid \text{kW}] \quad (8.27a)$$

it is clear from Equation (8.26) that the latent heat is given by

$$q_L = m_{su}(h_i - h_3) \quad [\text{Btu/hr} \mid \text{kW}] \quad (8.27b)$$

Equations (8.27) show that both sensible and latent loads are proportional to the supply-air mass flow rate. Graphically, Equations (8.27) indicate that the line segments  $su \rightarrow 3$  and  $3 \rightarrow i$  represent sensible and latent zone heat loads, respectively.

The sensible heat factor may be expressed as

$$\text{SHF} = q_s/q_t = [(h_1 - h_3)/(h_3 - h_{\text{su}}) + 1]^{-1} \quad [\text{dl}] \quad (8.28)$$

It is seen from Equation (8.28) and Figure 8.22 that the space sensible heat factor depends on the slope of the room condition line. The ASHRAE psychrometric chart includes a "protractor" that relates the *condition line* slope to the sensible heat factor. Thus the design indoor state and the cooling loads determine the room condition line.

Selection of the supply-air dry-bulb temperature together with the room condition line determines the supply-air state. The supply-air temperature must be chosen within the capabilities of available refrigeration cooling coils. Note that the coil cooling load

$$q_c = m_{\text{su}}(h_m - h_{\text{su}}) \quad [\text{Btu/hr} \mid \text{kW}]$$

exceeds the space-cooling load whenever warm ventilation air is provided.

The fan mass flow rate requirement may be evaluated from Equation (8.25) or (8.27) when the supply-air state is known. The fan volume flow rate is then  $m_{\text{su}}v_m$  [ $\text{ft}^3/\text{hr} \mid \text{m}^3/\text{s}$ ]. However, it is usually quoted in  $\text{ft}^3/\text{min}$  or CFM as

$$\text{CFM} = m_{\text{su}}v_m/60 \quad [\text{ft}^3/\text{min}]$$

where the mass flow rate is in  $\text{lb}_m/\text{hr}$  of dry air.

There is a significant tradeoff here which may be considered with the help of the psychrometric chart. Higher supply-air dry-bulb temperatures allow higher evaporator coil temperatures, which improve the system cooling COP. However, the resulting lower supply-air to room-air temperature difference [according to Equation (8.25)] implies a larger air flow rate and thus a larger fan and larger ducts.

A moisture mass balance on the cooling coil gives the mass rate of condensation of water from the supply air:

$$m_w = m_{\text{su}}(W_m - W_{\text{su}}) \quad [\text{lb}_m/\text{hr} \mid \text{kg/s}]$$

It should be recognized that this is usually greater than the rate of removal of water vapor from the zone because of the higher vapor content of the ventilation air.

### EXAMPLE 8.10

A single zone is to be maintained at 70°F dry-bulb and 50 % relative humidity by a refrigeration coil in a forced-air system. The total cooling load on the zone is 55,000 Btu/hr and the latent load is 11,000 Btu/hr. Outdoor air at 98°F dry-bulb and 80°F wet-bulb is provided at a mass rate that is 25% of the supply-air rate. Air leaving the coil is at 50°F dry-bulb.

- Show the states of the indoor and outdoor air on a psychrometric chart and identify their enthalpy, wet-bulb temperature, humidity ratio, specific volume, and relative humidity.
- Show the mixture line and state on a psychrometric chart.
- Show the space and coil condition lines on a psychrometric chart. What are the

enthalpy, wet-bulb temperature, humidity ratio, specific volume, and relative humidity of the supply air?

- (d) What are the mass and volume flow rates of the outdoor and supply air?  
 (e) What is the total coil cooling load, in Btu/hr and in tons?

**Solution**

(a) From the psychrometric chart, the zone and outdoor properties are:

$T_{DBi} = 70^\circ\text{F}$	$T_{DBe} = 98^\circ\text{F}$
$\Phi_i = 50\%$	$T_{WB e} = 80^\circ\text{F}$
$W_i = 0.0078$	$W_e = 0.018$
$h_i = 25.3 \text{ Btu/lb}_m\text{da}$	$h_e = 43.4 \text{ Btu/lb}_m\text{da}$
$v_i = 13.51 \text{ ft}^3/\text{lb}_m\text{da}$	$v_e = 14.47 \text{ ft}^3/\text{lb}_m\text{da}$
$T_{WB i} = 58^\circ\text{F}$	$\Phi_e = 47\%$

(b) For the properties listed above and for  $m_o/m_m = 0.25$  in Equation (8.23), the mixture enthalpy and humidity ratio are

$$h_m = 25.3 + 0.25(43.4 - 25.3) = 29.83 \text{ Btu/lb}_m\text{da}$$

$$W_m = 0.0078 + 0.25(0.018 - 0.0078) = 0.01035 \text{ lb}_m/\text{lbda}$$

It is seen in Figure 8.22 that these properties verify that the mixture state lies on a straight line between the outdoor and indoor states. Thus the mixture line and either  $h_m$  or  $W_m$  could have been used to identify state m. The mixture dry-bulb temperature read from the chart is  $77^\circ\text{F}$  and the specific volume is  $13.7 \text{ ft}^3/\text{lb}_m\text{da}$ .

(c) The sensible heat factor is  $\text{SHF} = 44,000/55,000 = 0.8$ . A line parallel to the room condition line is obtained using the chart protractor and the space sensible heat factor. Using two triangles, a parallel line through state i gives the space (room) condition line shown in Figure 8.22. From the intersection of the space condition line and the  $50^\circ\text{F}$  dry-bulb temperature line, the supply-air properties are:

$$\begin{aligned} h_{su} &= 19.2 \text{ Btu/lb}_m\text{da} \\ W_{su} &= 0.0066 \\ v_{su} &= 12.95 \text{ ft}^3/\text{lb}_m\text{da} \\ \Phi_{su} &= 86\% \end{aligned}$$

The coil condition line is drawn to connect states m and su.

(d) The enthalpy of the supply air rises as it mixes with room air. The rise rate must equal the total space load in order for the space temperature to remain unchanged. Thus

$$m_{su} = (q_s + q_L)/(h_i - h_{su}) = 55,000/(25.3 - 19.2) = 9016.4 \text{ lb}_m\text{da/hr}$$

Using the  $v_{su}$ , the supply air volume flow rate is  $9016.4(12.95)/60 = 1946 \text{ cfm}$ . Similarly, the

on-coil volume flow rate is  $9016.4(13.7)/60 = 2059$  cfm. The outdoor-air mass and volume flow rates are then, respectively,  $9016.4/4 = 2254.1$  lb<sub>m</sub>da/hr and  $2254.1(14.45)/60 = 543$  cfm. Note that, because of the different specific volumes, the outdoor-air volume flow rate is *not* one-fourth of the supply-air rate; and the supply-air and on-coil volume flow rates are not equal.

(e) The mixed ventilation and return air are cooled and dehumidified by heat transfer to the refrigeration coil. The coil load is therefore

$$q_{\text{coil}} = m_{\text{su}}(h_{\text{m}} - h_{\text{su}}) = 9016.4(29.83 - 19.2) = 95,844 \text{ Btu/hr, or } 95,844/12,000 = 8 \text{ tons}$$

The coil load is greater than the space-cooling load because of the cooling and dehumidification of the outdoor ventilation air.

### Dehumidification Without Cooling Coils

It was shown in Example 8.10 that dehumidification usually accompanies cooling in typical space-cooling systems using refrigerant coils. In industrial processes and other applications where precise humidity control is important, special equipment often is used. Substances known as *desiccants*, which absorb water vapor, may be employed in such dehumidification applications, alone or in combination with refrigerant coil cooling and dehumidification. Examples of solid desiccants are silica gel, lithium chloride, and activated alumina. You may have observed that cartons which contain merchandise that must be kept dry are often shipped with small packets of a desiccant such as silica gel.

The difference in water vapor pressure between neighboring regions is a driving force for water vapor transport by diffusion from the high-vapor-pressure region to the lower-pressure region. A desiccant absorbs water vapor from air adjacent to its surface, lowering the local vapor pressure and thereby attracting an inflow of additional vapor from the surroundings.

As a desiccant absorbs water vapor, however, the water vapor pressure at its surface gradually increases. The material will continue to accept water vapor until its vapor pressure equals or exceeds that of the surrounding air. Thus the material must be reactivated to continue the drying process. Since vapor pressure increases with temperature, a desiccant can be reactivated by heating it with hot air. At high temperatures the desiccant vapor pressure exceeds that of the surrounding air, and water vapor then passes from the desiccant to the surrounding air.

Commercial dehumidifiers may use liquid or solid desiccants. Figure 8.23(a) shows a schematic of a compact desiccant-wheel dehumidification system that has a wide range of industrial applications and that allows the drying of process air to a very low dew point. In the dehumidifier, the process air passes through a duct leading to a sector of a rotating, fiberglass-composite honeycomb wheel having many small passages impregnated with lithium chloride desiccant. The water-laden sector rotates slowly into another duct, sealed off from

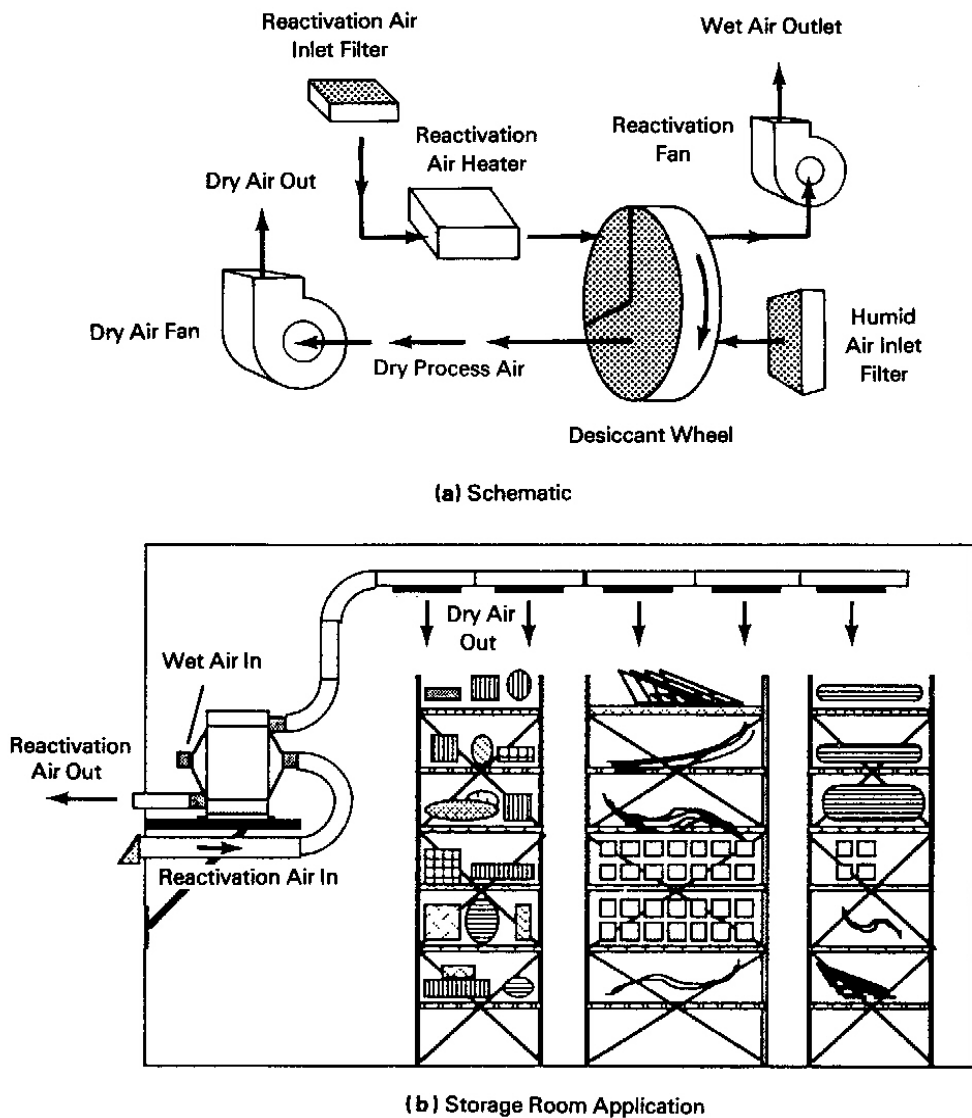

**FIGURE 8.23** Desiccant-wheel dehumidifier. (Courtesy of Munters Cargocaire Engineering Corp.) (a) Schematic. (b) Storage room application.

the process air, through which a separate air flow passes at a temperature from 250°–300° F. This hot air reactivates the desiccant in preparation for its next exposure to the process air. Though heat (not work) is required to reactivate the desiccant, the process requires less energy than other dehumidification processes. A desiccant-wheel storage room installation is shown in Figure 8.23(b). As in the figure, heated outdoor air is usually provided for reactivation of the desiccant. The reader is referred to references 11 and 12 for further information on desiccant dehumidification.

## Bibliography and References

1. Parsons, Robert A. (Ed.), *ASHRAE Handbook of Fundamentals*. Atlanta: American Society of Heating, Refrigerating, and Air-Conditioning Engineers, 1989, p. 16.3.
2. McQuiston, Faye C. and Parker, Jerald D., *Heating Ventilating, and Air Conditioning*, 3<sup>rd</sup> ed. Wiley, New York, N.Y., 1988.
3. Stoecker, W. F. and Jones, J. W., *Refrigeration and Air Conditioning*, 2<sup>nd</sup> ed. McGraw-Hill, New York, N.Y., 1982.
4. Threlkeld, James L., *Thermal Environmental Engineering*, 2<sup>nd</sup> ed. Prentice-Hall, Inc., Engelwood Cliffs, N.J., 1970.
5. Jennings, Burgess H., *The Thermal Environment – Conditioning and Control*, Harper and Row, 1978.
6. Stoecker, W.F., *Design of Thermal Systems*, 3<sup>rd</sup> ed. McGraw-Hill, New York, N.Y., 1989.
7. Goff, John A. and Gratch, S., "Thermodynamic Properties of Moist Air," *ASHRAE Handbook of Fundamentals*, Atlanta: American Society of Heating, Refrigerating, and Air-Conditioning Engineers, 1972.
8. Derra, Skip, "CFCs No Easy Solutions," *R&D Magazine*, May 1990, pp. 56-66.
9. Moore, Taylor, "CFCs: The Challenge of Doing Without," *EPRI Journal*, Vol. 14, No. 6, September 1989.
10. Purvis, Ed, "Applications of Scroll Compressors in Heat Pumps," *Energy Technology XVI*, Government Institutes, Inc., February 1989, pp. 410-420.
11. Parsons, Robert A. (Ed.), "Sorbents and Desiccants," *ASHRAE Handbook of Fundamentals*. Atlanta: American Society of Heating, Refrigerating, and Air-Conditioning Engineers, 1989, Ch 19.
12. Parsons, Robert A. (Ed.), "Sorption Dehumidification and Pressure Drying Equipment," *ASHRAE Handbook of Equipment*. Atlanta: American Society of Heating, Refrigerating, and Air-Conditioning Engineers, 1988, Ch 7.
13. Althouse, Andrew D., et al., *Modern Refrigeration and Air-Conditioning*. South Holland, Ill.: Goodheart-Wilcox Co., 1975.

14. York, Thomas, "Heat Pumps: Developing the Dual Fuel Option," *EPRI Journal*, December 1990, pp. 22-27.
15. Public Law 101-549, "An Act to Amend the Clean Air Act to Provide for Attainment and Maintenance of Health Protection, National Air Quality Standards, and Other Purposes," November 15, 1990.
16. Anon., *Refrigeration and Ice Making*. Alymer, Ontario: Ontario Arenas Association Inc., March 1988.

## EXERCISES

- 8.1 Derive a relationship between the coefficient of performances for the heat pump and refrigerator using the ideal cycles of Figure 8.1.
- 8.2 Carefully sketch a flow diagram and T-s diagram for a refrigeration cycle that uses a single heat exchanger for suction line heating and condenser discharge subcooling. Explain how the addition of this heat exchanger influences the cycle refrigeration effect?
- 8.3 Derive the conversion factors in Btu/hr and in kJ/hr, for a ton of refrigeration, based on the latent heat of fusion of ice of 144 Btu/lb.
- 8.4 Derive the following convenient relation for the horsepower required to produce a cooling capacity of one ton of refrigeration: horsepower/ton = 4.72/COP.
- 8.5 When shopping for an air conditioner, one encounters labels that give the product's EER. What is the coefficient of performance for an air conditioner with an EER of 9.3?
- 8.6 Determine the capacity and COP of a vapor compression chiller operating with a reciprocating compressor between 35°C condensing and -10°C evaporating with *refrigerant 22*. The compressor has a volumetric efficiency of 70% and operates at 1800 rpm with a displacement volume of 750 cubic centimeters.
- 8.7 Compare the refrigeration effect, compressor work, and COP<sub>r</sub> for refrigerants 12 and 22 for a refrigeration system that has a 40°F evaporator and condenses at 140°F.
- 8.8 Compare the refrigeration effect, COP<sub>r</sub>, compressor work, and EER for an R-12 refrigeration unit with 120°F condensing and 50°, 30°, and 10°F evaporators. Tabulate the results.
- 8.9 Compare the refrigeration effect, COP<sub>r</sub>, compressor work, and EER for an R-22 refrigeration unit with 120°F condensing and 50°, 30°, and 10°F evaporators. Tabulate the results.

- 8.10 Compare the refrigeration effect,  $COP_r$ , compressor work, and EER for an R-22 refrigeration unit with 100°, 120°, and 140°F condensing and 50°F evaporator. Tabulate the results.
- 8.11 Compare the refrigeration effect,  $COP_r$ , compressor work, and EER for an R-12 refrigeration unit with 100°, 120°, and 140°F condensing and 50°F evaporator. Tabulate the results.
- 8.12 Compare the results of Exercise 8.10 with those for a similar system, accounting for a compressor with a 75% isentropic efficiency.
- 8.13 Compare the results of Exercise 8.11 with those for a similar system, accounting for a compressor with a 75% isentropic efficiency.
- 8.14 Consider a two-stage refrigeration system that operates with a 40°F evaporator and condenses at 140°F. Draw labeled T-s and flow diagrams for the cycle that consists of two ideal vapor compression cycles connected by a heat exchanger that serves as the condenser for the low-pressure cycle and the evaporator for the high-pressure cycle. The evaporating and condensing temperature in the heat exchanger is 80°F. For R-12, determine the ratio of refrigerant flows for the two cycles and compare the refrigeration effect, total compressor work,  $COP_r$ , and EER with that for the single-stage system.
- 8.15 Consider a two-stage refrigeration system that operates with a 40° F evaporator and condenses at 140°F. Draw labeled T-s and flow diagrams for the cycle that consists of two ideal vapor compression cycles connected by a heat exchanger that serves as the condenser for the low-pressure cycle and the evaporator for the high-pressure cycle. The evaporating and condensing temperature in the heat exchanger is 80°F. For R-22, determine the ratio of refrigerant flows for the two cycles; and compare the refrigeration effect and the total compressor work per unit mass in the evaporator, the  $COP_r$ , and the EER with that for the single-stage system.
- 8.16 A Diesel engine develops 500 horsepower at an efficiency of 38%. Almost all of the heat loss from the engine is transferred through the lubricating oil, through the cooling water, and through an exhaust gas heat exchanger to the generator of an absorption refrigeration system with a COP of 0.8. Derive an equation for the capacity of the evaporator in terms of the engine efficiency and power output and the COP of the refrigeration system. What is the capacity of the evaporator of the refrigeration system in Btu/min and in tons?
- 8.17 The volumetric efficiency,  $m v_s / (N \cdot \text{disp})$ , of a reciprocating compressor may be crudely modeled as:

$$\text{Vol. eff.} = 1 + C - Cr^{(1/n)}$$



where  $C$  is the ratio of the clearance volume to the piston displacement  $\text{disp}$ ,  $v_s$  is the compressor suction specific volume,  $r$  is the compressor pressure ratio, and  $n$  is the polytropic exponent. Taking  $C = 0.15$  and  $n = 1.2$ , plot capacity and compressor power versus evaporator temperature for a condensing temperature of  $140^\circ\text{F}$  for R-12. The compressor has a  $3 \text{ in}^3$  displacement and operates at 1200 rpm.

- 8.18 To attempt to compare COPs for vapor compression and absorption refrigeration systems, consider a vapor compression system (with  $\text{COP}_r$ ) driven by a heat engine (with efficiency  $\eta_E$ ). The combined system is one that accepts heat from a high-temperature source and uses it to cool a low-temperature region. Work out an equation for the COP for the combined system  $\text{COP}_a$ , and compare it with the  $\text{COP}_r$  for the corresponding vapor compression system. What is  $\text{COP}_a$ , when  $\text{COP}_r = 6$  and the engine efficiency is 25%?
- 8.19 Determine the COP of an ideal vapor-compression-refrigeration system using R-22 with a  $40^\circ\text{F}$  evaporator and a condensing temperature of  $110^\circ\text{F}$ . Next, assume that the work for the system is provided by a Carnot engine operating between  $250^\circ\text{F}$  and  $100^\circ\text{F}$  reservoirs. Diagram the system. Considering the combined system as a model of an absorption system, compare its absorption COP with the COP of the vapor compression system alone. Discuss the conditions under which higher-absorption COPs could be attained.
- 8.20 Sketch and discuss thoroughly the slope and variation of lines of constant enthalpy on the psychrometric chart.
- 8.21 Compare the sea level relative humidity, enthalpy, specific volume, wet-bulb temperature, and dew point using (a) steam tables and ideal gas mixture relations and (b) the psychrometric chart for the following conditions:
1.  $60^\circ\text{F}$  dry-bulb,  $W = 0.01$ .
  2.  $90^\circ\text{F}$  dry-bulb,  $W = 0.02$ .
  3.  $90^\circ\text{F}$  dry-bulb,  $W = 0.01$ .
- 8.22 Compare the sea level humidity ratio, enthalpy, specific volume, wet bulb temperature and dew point using (a) steam tables and ideal gas relations and (b) the psychrometric chart for the following conditions:
1.  $60^\circ\text{F}$  dry-bulb,  $\Phi = 50\%$
  2.  $90^\circ\text{F}$  dry-bulb,  $W = 80\%$
  3.  $90^\circ\text{F}$  dry-bulb,  $W = 40\%$
- 8.23 Compare the sea level relative humidity, humidity ratio, enthalpy, specific volume, and dew point using (a) steam tables and ideal gas relations, and (b) the psychrometric chart for the following conditions:
1.  $60^\circ\text{F}$  dry-bulb,  $55^\circ\text{F}$  wet-bulb.

2. 90°F dry-bulb, 55°F wet-bulb.
  3. 90°F dry-bulb, 80°F wet-bulb.
- 8.24 Two hundred lb<sub>m</sub>/hr of moist air at 65°F dry-bulb and 50°F wet-bulb temperatures mixes with 40 lb<sub>m</sub>/hr of air at 100°F and 85°F wet-bulb. What is the mixture dry-bulb temperature, humidity ratio, relative humidity, and dew point? What are these parameters if the second stream flow rate is increased to 80 lb<sub>m</sub>/hr?
- 8.25 One hundred lb<sub>m</sub>/hr of moist air at 70°F dry-bulb and 50% relative humidity mixes with 35 lb<sub>m</sub>/hr of air at 90°F wet-bulb and 70% relative humidity. What are the mixture dry-bulb and wet-bulb temperatures, humidity ratio, relative humidity, enthalpy, specific volume, and dew point?
- 8.26 Determine the sensible, latent, and total heat transfer for moist air flowing over a cooling coil. The on-coil wet-bulb and dry-bulb temperatures are 85°F and 105°F, respectively, and the coil-leaving conditions are 60°F dry-bulb and 60% relative humidity. How much water is condensed per unit mass of dry air?
- 8.27 Determine the sensible, latent, and total heat transfer for moist air flowing over a cooling coil. The on-coil wet-bulb and dry-bulb temperatures are 75°F and 95°F, respectively, and the coil-leaving conditions are 50°F dry-bulb and 85% relative humidity. How much water is condensed per unit mass of dry air?
- 8.28 Air at sea level has a dry-bulb temperature of 80°F and an adiabatic saturation temperature of 60°F. Evaluate the humidity ratio, relative humidity, and dew point temperature using (a) equations and steam tables and (b) the psychrometric chart method.
- 8.29 Air at sea level has a dry-bulb temperature of 85°F and an adiabatic saturation temperature of 55°F. Evaluate the humidity ratio, relative humidity, and dew point temperature using (a) equations and steam tables and (b) the psychrometric chart method.
- 8.30 A zone is to be maintained at 72°F dry-bulb and 50% relative humidity. The zone sensible and latent loads are 150,000 Btu/hr and 50,000 Btu/hr, respectively. The supply-air temperature is to be 48°F. What is the supply-air mass flow rate and volume flow rate?
- 8.31 Rework the parts of Example 8.10 that are changed by reducing ventilation air to 10% of supply air. Compare the coil cooling load and volume flow rate with the given results.
- 8.32 Rework the parts of Example 8.10 that are changed by increasing the supply-air dry-

bulb temperature to 55°F. Compare the coil mass and volume flow rates and cooling load with the given results.

- 8.33 A room is to be maintained at 74°F dry-bulb and 62°F wet-bulb by a vapor compression air conditioner. The total cooling load on the zone is 24,000 Btu/hr, and the latent load is 4,000 Btu/hr. Outdoor air is provided for ventilation at 100°F dry-bulb and 60% relative humidity. The ventilation mass rate is 15% of the supply-air rate. Air leaving the coil is at 52°F dry-bulb.
- (a) Show the significant states and processes on the psychrometric chart, and construct a table of wet- and dry-bulb and dew point temperatures, enthalpy, humidity ratio, specific volume and relative humidity for the space, outdoor, mixture, and supply- air conditions.
  - (b) What are the mass and volume flow rates of return air, ventilation air, and supply air?
  - (c) What is the coil cooling load in Btu/hr and in tons?
- 8.34 Resistance heaters are switched on in 5-kW increments to satisfy the demand for heat from the electric heat pump system characterized by Figure 8.15. At what temperatures should the first and second 5-kW banks be turned on?
- 8.35 Indicate whether the following are true or false:
- (a) An isotherm on a steam p-V diagram is a line of constant relative humidity for a given total moist air pressure.
  - (b) The saturated vapor line on a steam p-V diagram is a line of constant relative humidity for a given total moist air pressure.
  - (c) Increasing partial pressure of water vapor for fixed moist air pressure always increases relative humidity.
  - (d) Increasing partial pressure of water vapor for a fixed moist air pressure and fixed dry-bulb temperature always increases relative humidity.
  - (e) Decreasing dry-bulb temperature for fixed moist air pressure and fixed water vapor pressure always increases relative humidity.