

**STP 5-51B12-SM-TG**

**Carpentry and Masonry  
Specialist Skill Levels 1/2  
MOS 51B, Soldier's Manual  
and Trainer's Guide**

DISTRIBUTION RESTRICTION: Approved for public release; distribution is unlimited.

DESTRUCTION NOTICE: Destroy by any method that will prevent disclosure of contents or reconstruction of the document.

**HEADQUARTERS  
DEPARTMENT OF THE ARMY**



# SOLDIER'S MANUAL and TRAINER'S GUIDE

## MOS 51B

### Carpentry and Masonry Specialist Skill Levels 1/2 MOS 51B, Soldier's Manual and Trainer's Guide

#### Skill Levels 1 and 2

#### TABLE OF CONTENTS

	<u>PAGE</u>
<b>Table of Contents</b> .....	<b>i</b>
<b>PREFACE</b> .....	<b>iv</b>
<b>Chapter 1. Introduction</b> .....	<b>1-1</b>
<b>Chapter 2. Training Guide</b> .....	<b>2-1</b>
2-1. General.....	2-1
2-2. Subject Area Codes .....	2-2
2-3. Duty Position Training Requirements.....	2-2
2-4. Critical Tasks List .....	2-3
<b>Chapter 3. MOS/Skill Level Tasks</b> .....	<b>3-1</b>
<b>Skill Level 1</b>	
<b>Subject Area 1: Basic Mine Warfare</b>	
051-192-1021 LOCATE MINES BY VISUAL MEANS .....	3-1
051-192-1105 INSTALL AN M15 ANTITANK (AT) MINE USING THE M624 FUZE.....	3-3
051-192-1106 REMOVE AN M15 ANTITANK (AT) MINE WITH THE M624 FUZE .....	3-13
051-192-1107 INSTALL AN M15 ANTITANK (AT) MINE USING THE M603 FUZE.....	3-16

<sup>\*</sup>DISTRIBUTION RESTRICTION: Approved for public release; distribution is unlimited.

DESTRUCTION NOTICE: Destroy by any method that will prevent disclosure of contents or reconstruction of the document.

This publication supersedes STP 5-51B12-SM-TG, 19 August 1987.

051-192-1108	REMOVE AN M15 ANTITANK (AT) MINE WITH THE M603 FUZE .....	3-22
051-192-1109	INSTALL AN M19 ANTITANK (AT) MINE .....	3-24
051-192-1110	REMOVE AN M19 ANTITANK (AT) MINE .....	3-28
051-192-1117	INSTALL AN M21 ANTITANK (AT) MINE .....	3-29
051-192-1118	REMOVE AN M21 ANTITANK (AT) MINE .....	3-35
051-192-1128	LOCATE MINES WITH THE AN/PSS-12 MINE DETECTOR.....	3-38
051-192-1154	INSTALL AN M5 PRESSURE-RELEASE FIRING DEVICE ON ANTITANK (AT) MINES.....	3-43
051-192-1155	REMOVE AN M5 PRESSURE-RELEASE FIRING DEVICE FROM ANTITANK (AT) MINES.....	3-49
<b>Subject Area 2: Basic Demolitions</b>		
051-193-1013	NEUTRALIZE BOOBY TRAPS .....	3-51
051-193-1101	INSTALL AN M142 MULTIPURPOSE FIRING DEVICE.....	3-62
051-193-1102	REMOVE AN M142 MULTIPURPOSE FIRING DEVICE.....	3-66
051-193-1310	CONSTRUCT DEMOLITION FIRING SYSTEMS.....	3-68
051-193-1311	PRIME MILITARY EXPLOSIVES.....	3-81
051-193-1312	CONSTRUCT DEMOLITION INITIATING SETS .....	3-99
051-193-1313	IDENTIFY CHARACTERISTICS OF MILITARY DEMOLITIONS AND EXPLOSIVES.....	3-104
<b>Subject Area 3: Basic Combat Construction</b>		
051-195-1020	INSTALL WIRE OBSTACLE MATERIALS.....	3-105
<b>Subject Area 4: Basic Rigging</b>		
051-200-1075	TIE KNOTS.....	3-114
<b>Subject Area 5: Construction Drawing</b>		
051-236-1202	INTERPRET CONSTRUCTION DRAWINGS AND PRINTS .....	3-118
<b>Subject Area 6: Construction Planning and Materials</b>		
051-236-1184	IDENTIFY BUILDING MATERIALS.....	3-123
<b>Subject Area 7: Building Layout and Foundations</b>		
051-236-1162	INSTALL BATTER BOARDS.....	3-130
<b>Subject Area 8: Wood Structures</b>		
051-236-1141	CONSTRUCT A FLOOR SYSTEM .....	3-137
051-236-1143	CONSTRUCT STAIRS .....	3-146
051-236-1144	CONSTRUCT A ROOF SYSTEM .....	3-152
051-236-1173	FABRICATE JOINTS AND SPLICES.....	3-159
051-236-1201	INSTALL EXTERIOR FINISH.....	3-163
051-236-1203	CONSTRUCT A WALL SYSTEM.....	3-169
<b>Subject Area 9: Finish Carpentry</b>		
051-236-1174	APPLY INTERIOR TRIM.....	3-175
051-236-1177	INSTALL SHEETROCK (DRYWALL).....	3-179
<b>Subject Area 10: Floor and Wall Tile</b>		
051-236-1176	INSTALL RESILIENT FLOOR TILE .....	3-184
051-236-1189	INSTALL SUSPENDED CEILING .....	3-188
051-236-1192	INSTALL CERAMIC WALL TILE .....	3-196
<b>Subject Area 11: Roof Systems and Coverings</b>		
051-236-1172	APPLY ROOF COVERINGS.....	3-200
<b>Subject Area 12: Maintenance</b>		
051-236-1147	PERFORM MAINTENANCE ON CARPENTRY/MASONRY TOOLS .....	3-205

<b>Subject Area 13: Concrete Structures</b>	
051-236-1163	CONSTRUCT A CONCRETE-WALL FORM..... 3-208
051-236-1164	CONSTRUCT A COLUMN FORM ..... 3-213
051-236-1165	CONSTRUCT AN OVERHEAD FORM ..... 3-216
051-236-1166	CONSTRUCT A CONCRETE-SLAB FORM ..... 3-219
<b>Subject Area 14: Concrete Placement</b>	
051-236-1167	PERFORM A SLUMP TEST ON CONCRETE..... 3-224
051-236-1168	PLACE CONCRETE..... 3-228
<b>Subject Area 15: Masonry Structure</b>	
051-236-1146	CONSTRUCT A MASONRY WALL ..... 3-231
<b>Subject Area 16: Planning</b>	
051-236-1183	PREPARE A MATERIALS TAKE-OFF LIST ..... 3-240
<b>Skill Level 2</b>	
<b>Subject Area 17: Wood Structures</b>	
051-236-2109	INSTALL DOORS AND WINDOWS..... 3-244
<b>Subject Area 18: Sawmill Operations (RC)</b>	
051-236-2114	SET UP/OPERATE A TRAILER-MOUNTED SAWMILL (RESERVE COMPONENT [RC]) ..... 3-251
<b>APPENDIX A - TRAINING AMMUNITION</b>	<b>90-1</b>
<b>APPENDIX B - DEPARTMENT OF THE ARMY (DA) FORM 5164-R (HANDS-ON EVALUATION)</b>	<b>91-1</b>
<b>APPENDIX C - DEPARTMENT OF THE ARMY (DA) FORM 5165-R (FIELD EXPEDIENT SQUAD BOOK)</b>	<b>92-1</b>
<b>APPENDIX D - CONVERSION FACTORS (UNITED STATES (US) UNITS AND METRIC)</b>	<b>93-1</b>
<b>Glossary</b>	<b>88-1</b>
<b>Supporting References</b>	<b>99-1</b>

## PREFACE

This publication is for skill levels (SLs) 1 and 2 soldiers holding military occupational specialty (MOS) 51B and their trainer or first-line supervisors. It contains standardized training objectives in the form of task summaries, that may be used to train and evaluate critical tasks that support unit missions during wartime. Soldiers holding MOS 51B should have access to this publication. Trainers and first-line supervisors should actively plan for soldiers to have access to this publication.

Reserve Components (RC) (Army National Guard-Army Reserve). Most tasks in this manual are applicable to both the Active and RC soldier. However, some tasks are only for active duty soldiers due to differences of equipment and missions. Tasks unique to RC soldiers are identified by (RC) following the task title and grouped into RC unique subject areas.

Users of this publication are encouraged to recommend changes and submit comments for its improvement. Comments should be keyed to specific page, paragraph, and line of the text in which the change is recommended. Reasons will be provided for each comment to ensure understanding and complete evaluation.

Unless this publication states otherwise, masculine nouns and pronouns do not refer exclusively to men.

## CHAPTER 1

### Introduction

#### GENERAL

1-1. This manual identifies the individual military occupational specialty (MOS) training requirements for soldiers in MOS 51B. It is designed to be used by commanders, trainers, and soldiers to plan, conduct, and evaluate individual training in units. This manual is the primary reference to support that portion of the Integrated Test/Evaluation Program (ITEP) that requires commanders to routinely evaluate soldier ability to perform MOS-specific tasks critical to the unit mission. Army Regulation (AR) 350-41 describes the ITEP in detail.

1-2. This manual should be used along with Soldier Training Publications (STPs) 21-1-Soldier's Manual of Common Tasks (SMCT) and 21-24-SMCT; Army Training and Evaluation Programs (ARTEPs); and Field Manuals (FMs) 25-4, 25-5, 25-100, and 25-101 to establish effective training plans and programs that integrate individual and collective tasks.

#### TASK SUMMARIES

1-3. Task summaries contain information necessary to conduct training and evaluate soldier proficiency on tasks critical to the MOS. A separate task summary is provided for each critical task. These task summaries are, in effect, standardized training objectives which ensure that soldiers do not have to relearn a task on reassignment to a new unit. The format for the task summaries included in this manual is as follows:

- *Task Title.* The task title identifies the action to be performed.
- *Task Number.* A 10-digit number identifies each task or skill. Include this task number, along with task title, in any correspondence relating to the task.
- *Conditions.* The task conditions identify all the equipment, tools, references, job aids, and supporting personnel that the soldier needs to perform the task in wartime. This section identifies any environmental conditions that can alter task performance, such as visibility, temperature, and wind. This section also identifies any specific cues or events (a chemical attack or identification of a threat vehicle) that trigger task performance.
- *Standards.* The task standards describe how well and to what level you must perform a task under wartime conditions. Standards are typically described in terms of accuracy, completeness, and speed.
- *Training and Evaluation.* This section may contain all or part of the following: training information outline, evaluation preparation subsection, and evaluation guide. The training information outline includes detailed training information. The evaluation preparation subsection indicates necessary modifications to task performance in order to train and evaluate a task that cannot be trained to the wartime standard under wartime conditions. It may also include special training and evaluation preparation instructions to accommodate these modifications and any instruction that should be given to the soldier before evaluation. The evaluation guide identifies the specific actions, known as performance measures, that the soldier must do to successfully complete the task. These actions are listed in a *pass/fail* format for easy evaluation. Each evaluation guide contains a feedback statement that indicates the requirements for receiving a *GO* on the evaluation.

- *References.* This section identifies references that provide more detailed and thorough explanations of task performance requirements than that given in the task summary description.

1-4. Additionally, some task summaries include safety statements and notes. Safety statements (danger, warning, and caution) alert users to the possibility of immediate death, personal injury, or damage to equipment. Notes provide a small, extra supportive explanation or hint relative to the performance measures.

## **SOLDIER'S RESPONSIBILITIES**

1-5. Each soldier is responsible for performing individual tasks which the first-line supervisor identifies based on the unit's mission essential task list (METL). The soldier must perform the task to the standards listed in the soldier's manual (SM). If a soldier has a question about how to do a task or which tasks in this manual he must perform, it is the soldier's responsibility to ask the first-line supervisor for clarification. The first-line supervisor knows how to perform each task or can direct the soldier to the appropriate training materials.

## **NONCOMMISSIONED OFFICER SELF-DEVELOPMENT AND THE SOLDIER'S MANUAL**

1-6. Self-development is one of the key components of the leader development program. It is a planned, progressive, and sequential program followed by leaders to enhance and sustain their military competency. It consists of individual study, research, professional reading, practice, and self-assessment. Under the self-development concept, the noncommissioned officer (NCO), as an Army professional, has the responsibility to remain current in all phases of the MOS. The SM is the primary source for the NCO to use in maintaining MOS proficiency.

1-7. Another important resource for NCO self-development is the Army Correspondence Course Program (ACCP). (See Department of the Army (DA) Pamphlet 351-20 for information on enrolling in this program and for a list of courses, or write to: Army Institute for Professional Development, United States (US) Army Training Support Center, ATTN: ATIC-IPS, Newport News, Virginia 23628-0001.)

1-8. Unit learning centers are valuable resources for planning self-development programs. They can help access enlisted career maps, training support products, and extension training materials.

## **TRAINING SUPPORT**

1-9. This manual includes the following appendixes and information that provide additional training support information:

- *Appendix A, Training Ammunition.* This appendix lists the mines and explosives, live and inert, required to support the training of critical tasks contained in the SM.
- *Appendix B, Department of the Army (DA) Form 5164-R (Hands-On Evaluation).* This appendix provides an overprinted copy of DA Form 5164-R for the tasks contained in the SM. The NCO trainer can use this form to set up the leader book described in FM 25-101. The use of this form may help preclude writing the soldier tasks associated with the unit's METL and can become a part of the leader book.
- *Appendix C, Department of the Army (DA) Form 5165-R (Field Expedient Squad Book).* This appendix provides an overprinted copy of DA Form 5164-R for the tasks contained in the SM. The NCO trainer can use this form to set up the leader book described in FM 25-101. The use of this form may help preclude writing the soldier tasks associated with the unit's METL and can become a part of the leader book.



- *Appendix D, Conversion Factors (United States (US) Units and Metric).* This appendix provides an English to metric measurement conversion chart.
- *Glossary.* This glossary is a single comprehensive list of acronyms, abbreviations, definitions, and letter symbols.
- *References.* This section contains two lists of references, required and related, that support training of all tasks in this SM. Required references are listed in the conditions statement and are required for the soldier to do the task. Related references are materials that provide more detailed information and a more thorough explanation of task performance.

**ENLISTED PERSONNEL MANAGEMENT SYSTEM**

1-10. The Enlisted Personnel Management System (EPMS) (AR 614-200) is the Army's overall system to improve the professionalism of the enlisted force. It integrates policies relating to training, evaluation, classification, and promotion into an overall system. It provides the soldier with a means to look to the future and see a realistic, clear, and viable career progression path from private to sergeant major (SGM). However, the EPMS is useless if the soldier does not understand and use it. Part of the trainer's job is to make sure the soldier understands and uses the EPMS. As an aid, Figure 1-1 provides the trainer with a career map for the 51B soldier. Along with information contained in AR 614-200, the soldier can use the career map to develop goals early in his career and plan accordingly.

NCOES	PLDC	BNCOC	ANCOC	USASM		
Civilian schools	High school, GED diploma	College*				
		1 year	2 years	3 years		
		A goal: troop assignments often preclude off duty education.				
Other schools	Drill Sergeant School Recruiting School Battle Staff Course 1SG Course					
Encouraged assignments	Retention, recruiter Drill sergeant Instructor Ops/intel/recon sergeant *Construction sergeant Inspector/foreman Reserve Component advisor CMF 51 staff assignments					
Key leadership assignments	Technician	Team ldr	Sqd ldr Sec ldr	Plt/sec SGT	1SG	CSM
Rank	PVT, PFC SPC, CPL	SGT	SSG	SFC	1SG MSG	SGM CSM
Years of service	1-4	3-8	6-14	10-18	16-22	20+

Figure 1-1 Career Progression Path

**SKILL PROGRESSION CHART**

1-11. Similar or related education, training, and experience are grouped into career management fields (CMFs). The career progression path for MOS 51B, CMF 51, Carpentry and Masonry, is shown in Figure 1-2.

E-9	00Z50 Command Sergeant Major
SL 5 E-8 through E-9	51Z50 General Engineering Supervisor
SL 4 (E-7)	51H40 Construction Engineering Supervisor
SL 3 (E-6)	51H30 Construction Engineering Supervisor
SL 2 (E-5)	51B20 Senior Carpenter/Masonry  51K20 Senior Plumber  51R20 Senior Electrician
SL 1 (E-1 through E-4)	51B10 Carpenter/Masonry  51K10 Plumber  51R10 Electrician
	Trainee

Figure 1 Career progression for engineering

**CHAPTER 2**

**Training Guide**

2-1. General. The MOS Training Plan (MTP) identifies the essential components of a unit training plan for individual training. Units have different training needs and requirements based on differences in environment, location, equipment, dispersion, and similar factors. Therefore, the MTP should be used as a guide for conducting unit training and not a rigid standard. The MTP consists of two parts. Each part is designed to assist the commander in preparing a unit training plan which satisfies integration, cross training, training up, and sustainment training requirements for soldiers in this MOS.

Part One of the MTP shows the relationship of an MOS skill level between duty position and critical tasks. These critical tasks are grouped by task commonality into subject areas.

Section I lists subject area numbers and titles used throughout the MTP. These subject areas are used to define the training requirements for each duty position within an MOS.

Section II identifies the total training requirement for each duty position within an MOS and provides a recommendation for cross training and train-up/merger training.

- **Duty Position column.** This column lists the duty positions of the MOS, by skill level, which have different training requirements.
- **Subject Area column.** This column lists, by numerical key (see Section I), the subject areas a soldier must be proficient in to perform in that duty position.
- **Cross Train column.** This column lists the recommended duty position for which soldiers should be cross trained.
- **Train-up/Merger column.** This column lists the corresponding duty position for the next higher skill level or MOSC the soldier will merge into on promotion.

Part Two lists, by general subject areas, the critical tasks to be trained in an MOS and the type of training required (resident, integration, or sustainment).

- **Subject Area column.** This column lists the subject area number and title in the same order as Section I, Part One of the MTP.
- **Task Number column.** This column lists the task numbers for all tasks included in the subject area.
- **Title column.** This column lists the task title for each task in the subject area.
- **Training Location column.** This column identifies the training location where the task is first trained to soldier training publications standards. If the task is first trained to standard in the unit, the word "Unit" will be in this column. If the task is first trained to standard in the training base, it will identify, by brevity code (ANCOC, BNCOC, etc.), the resident course where the task was taught. Figure 2-1 contains a list of training locations and their corresponding brevity codes.

<b>AIT</b>	Advanced Individual Training
<b>UNIT</b>	Trained in the Unit

Figure 2-1. Training Locations

- **Sustainment Training Frequency column.** This column indicates the recommended frequency at which the tasks should be trained to ensure soldiers maintain task proficiency. Figure 2-2 identifies the frequency codes used in this column.

<b>BA</b>	- Biannually
<b>AN</b>	- Annually
<b>SA</b>	- Semiannually
<b>QT</b>	- Quarterly
<b>MO</b>	- Monthly
<b>BW</b>	- Bi-weekly
<b>WK</b>	- Weekly

Figure 2-2. Sustainment Training Frequency Codes

- **Sustainment Training Skill Level column.** This column lists the skill levels of the MOS for which soldiers must receive sustainment training to ensure they maintain proficiency to soldier's manual standards.

2-2. Subject Area Codes.

**Skill Level 1**

- 1 Basic Mine Warfare
- 2 Basic Demolitions
- 3 Basic Combat Construction
- 4 Basic Rigging
- 5 Construction Drawing
- 6 Construction Planning and Materials
- 7 Building Layout and Foundations
- 8 Wood Structures
- 9 Finish Carpentry
- 10 Floor and Wall Tile
- 11 Roof Systems and Coverings
- 12 Maintenance
- 13 Concrete Structures
- 14 Concrete Placement
- 15 Masonry Structure
- 16 Planning

**Skill Level 2**

- 17 Wood Structures
- 18 Sawmill Operations (RC)

2-3. Duty Position Training Requirements.

2-4. Critical Tasks List.**MOS TRAINING PLAN  
51B12****CRITICAL TASKS****Skill Level**

<b>Subject Area</b>	<b>Task Number</b>	<b>Title</b>	<b>Training Location</b>	<b>Sust Tng Freq</b>	<b>Sust Tng SL</b>
1. Basic Mine Warfare	051-192-1021	LOCATE MINES BY VISUAL MEANS	AIT	AN	1
	051-192-1105	INSTALL AN M15 ANTITANK (AT) MINE USING THE M624 FUZE	AIT	AN	1
	051-192-1106	REMOVE AN M15 ANTITANK (AT) MINE WITH THE M624 FUZE	AIT	AN	1
	051-192-1107	INSTALL AN M15 ANTITANK (AT) MINE USING THE M603 FUZE	AIT	AN	1
	051-192-1108	REMOVE AN M15 ANTITANK (AT) MINE WITH THE M603 FUZE	AIT	AN	1
	051-192-1109	INSTALL AN M19 ANTITANK (AT) MINE	AIT	AN	1
	051-192-1110	REMOVE AN M19 ANTITANK (AT) MINE	AIT	AN	1
	051-192-1117	INSTALL AN M21 ANTITANK (AT) MINE	AIT	AN	1
	051-192-1118	REMOVE AN M21 ANTITANK (AT) MINE	AIT	AN	1
	051-192-1128	LOCATE MINES WITH THE AN/PSS-12 MINE DETECTOR	AIT	AN	1
	051-192-1154	INSTALL AN M5 PRESSURE-RELEASE FIRING DEVICE ON ANTITANK (AT) MINES	AIT	AN	1
	051-192-1155	REMOVE AN M5 PRESSURE-RELEASE FIRING DEVICE FROM ANTITANK (AT) MINES	AIT	AN	1
	2. Basic Demolitions	051-193-1013	NEUTRALIZE BOOBY TRAPS	AIT	MO
051-193-1101		INSTALL AN M142 MULTIPURPOSE FIRING DEVICE	AIT	AN	1
051-193-1102		REMOVE AN M142 MULTIPURPOSE FIRING DEVICE	AIT	AN	1
051-193-1310		CONSTRUCT DEMOLITION FIRING SYSTEMS	AIT	AN	1
051-193-1311		PRIME MILITARY EXPLOSIVES	AIT	AN	1
051-193-1312		CONSTRUCT DEMOLITION INITIATING SETS	AIT	AN	1
051-193-1313		IDENTIFY CHARACTERISTICS OF MILITARY DEMOLITIONS AND EXPLOSIVES	AIT	AN	1
3. Basic Combat Construction	051-195-1020	INSTALL WIRE OBSTACLE MATERIALS	AIT	AN	1
4. Basic Rigging	051-200-1075	TIE KNOTS	AIT	AN	1
5. Construction Drawing	051-236-1202	INTERPRET CONSTRUCTION DRAWINGS AND PRINTS	AIT	AN	1-2

## CRITICAL TASKS

## Skill Level

Subject Area	Task Number	Title	Training Location	Sust Tng Freq	Sust Tng SL
6. Construction Planning and Materials	051-236-1184	IDENTIFY BUILDING MATERIALS	UNIT	MO	1-2
7. Building Layout and Foundations	051-236-1162	INSTALL BATTER BOARDS	AIT	AN	1-2
8. Wood Structures	051-236-1141	CONSTRUCT A FLOOR SYSTEM	AIT	AN	1-2
	051-236-1143	CONSTRUCT STAIRS	AIT	AN	1-2
	051-236-1144	CONSTRUCT A ROOF SYSTEM	AIT	AN	1-2
	051-236-1173	FABRICATE JOINTS AND SPLICES	AIT	AN	1-2
	051-236-1201	INSTALL EXTERIOR FINISH	AIT	AN	1-2
	051-236-1203	CONSTRUCT A WALL SYSTEM	AIT	AN	1-2
9. Finish Carpentry	051-236-1174	APPLY INTERIOR TRIM	UNIT	MO	1-2
	051-236-1177	INSTALL SHEETROCK (DRYWALL)	UNIT	MO	1-2
10. Floor and Wall Tile	051-236-1176	INSTALL RESILIENT FLOOR TILE	UNIT	BM	1-2
	051-236-1189	INSTALL SUSPENDED CEILING	UNIT	MO	1-2
	051-236-1192	INSTALL CERAMIC WALL TILE	UNIT	MO	1-2
11. Roof Systems and Coverings	051-236-1172	APPLY ROOF COVERINGS	AIT	AN	1-2
12. Maintenance	051-236-1147	PERFORM MAINTENANCE ON CARPENTRY/MASONRY TOOLS	AIT	AN	1-2
13. Concrete Structures	051-236-1163	CONSTRUCT A CONCRETE-WALL FORM	AIT	AN	1-2
	051-236-1164	CONSTRUCT A COLUMN FORM	AIT	AN	1-2
	051-236-1165	CONSTRUCT AN OVERHEAD FORM	AIT	AN	1-2
	051-236-1166	CONSTRUCT A CONCRETE-SLAB FORM	AIT	AN	1-2
14. Concrete Placement	051-236-1167	PERFORM A SLUMP TEST ON CONCRETE	AIT	AN	1-2
	051-236-1168	PLACE CONCRETE	AIT	AN	1-2
15. Masonry Structure	051-236-1146	CONSTRUCT A MASONRY WALL	AIT	AN	1-2
16. Planning	051-236-1183	PREPARE A MATERIALS TAKE-OFF LIST	AIT	AN	1-2
17. Wood Structures	051-236-2109	INSTALL DOORS AND WINDOWS	AIT	AN	1-2
18. Sawmill Operations (RC)	051-236-2114	SET UP/OPERATE A TRAILER-MOUNTED SAWMILL (RESERVE COMPONENT [RC])	UNIT	AN	2

## CHAPTER 3

### MOS/Skill Level Tasks

#### Skill Level 1

#### Subject Area 1: Basic Mine Warfare

### LOCATE MINES BY VISUAL MEANS

#### 051-192-1021

**Conditions:** As a combat engineer squad member in a field environment, given an area with a possible minefield and different minefield characteristics.

**Standards:** Located possible mine sites and visually searched suspected areas for mines and trip wires. Ensured that no visible mines, parts of mines, or trip wires were overlooked.

#### Performance Steps

1. Locate possible mine sites by looking at the following areas:
  - a. Avenues of approach.
  - b. Key intersections and turnouts.
  - c. Trails, paths, and cleared spots in wooded areas.
  - d. Approaches and exits to bridges, fords, and tunnels.
  - e. Wood lines.
  - f. Depressions and ditches.
  - g. Open fields or grassland.
  
2. Search possible mine sites for suspected mines and trip wires by looking at the following areas:
  - a. Damaged vehicles.
  - b. Dead animals.
  - c. Areas avoided by the local population.
  - d. Signs of digging.
  - e. Signs of concrete or asphalt removal.
  - f. Holes or grooves in the road.
  - g. Boxes or parcels placed along the road or shoulder of the road.
  - h. Parked vehicles or bicycles without operators.
  - i. Wire on the road surface or extending onto the shoulder of the road.
  - j. Metallic devices on the road surface or extending onto the shoulder of the road.
  - k. Evidence of vegetation disturbance along the shoulders of the road.
  - l. Evidence of mine-peculiar supplies (such as wrenches, shipping plugs, wrapping paper, and safety collars from fuzes).
  - m. Disturbance of road potholes or puddles.
  - n. Difference in the amount of moisture or dew on the road surface.
  - o. Difference in plant growth (such as wilting, changed colors, or dead foliage).
  - p. Disturbance in previous tire tracks.
  - q. Signs posted on trees that covertly alert the local populace to the presence of mines.

**NOTE:** In addition to the above indicators, knowledge and recognition of likely threat mines, intelligence preparation of the battlefield, and plotting of likely ambush sites may also warn of buried mines.

3. Report all suspected areas to the noncommissioned officer in charge (NCOIC).

**Evaluation Preparation:** Setup: Provide a mined or simulated mined and trip-wired area that has different characteristics listed in the conditions. Brief soldier: Tell the soldier to look at the terrain and visually locate mined and trip-wired areas.

<b>Performance Measures</b>	<b>Results</b>	
1. Located possible mine sites.	P	F
2. Searched possible mine sites for suspected mines and trip wires.	P	F
3. Reported all suspected areas to the NCOIC.	P	F

**Evaluation Guidance:** Score the soldier GO if all steps are passed (P). Score the soldier NO-GO if any step is failed (F). If the soldier fails any step, show him how to do it correctly.

**References**  
**Required**

**Related**  
FM 20-32



**INSTALL AN M15 ANTITANK (AT) MINE USING THE M624 FUZE**  
**051-192-1105**

**Conditions:** As a combat engineer squad member in a field environment, given an M15 AT mine, an M624 fuze with tilt rod, an M20 arming wrench, G697 silicone grease, sandbags, and an entrenching tool.

**Standards:** Installed the M15 AT mine using an M624 fuze, in the proper sequence, without causing the mine to detonate.

**Performance Steps**

1. Inspect the mine (Figure 051-192-1105-1).

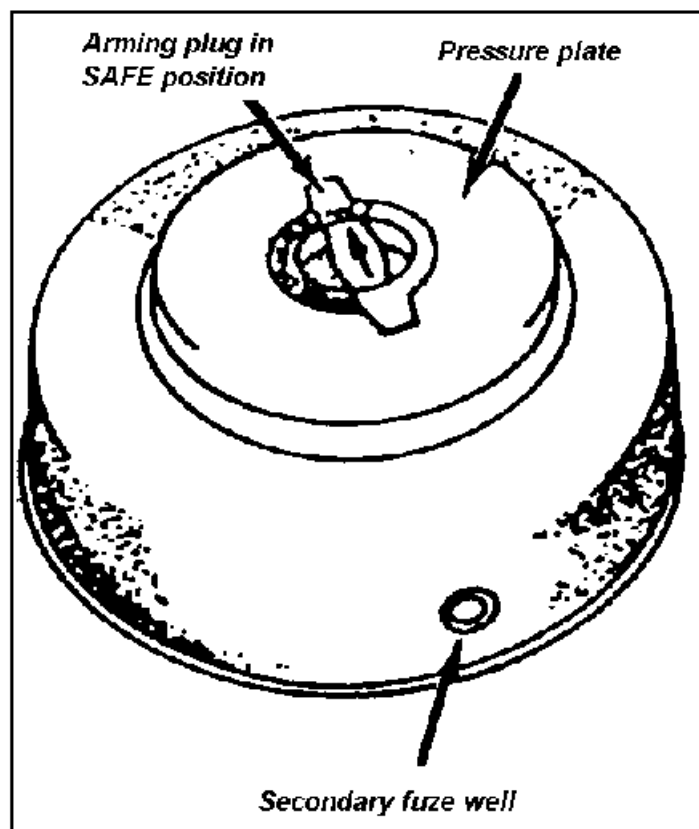

Figure 051-192-1105-1  
M15 AT mine

**CAUTION:** IF THERE IS A PROBLEM IN ANY OF THE FOLLOWING STEPS, NOTIFY THE NONCOMMISSIONED OFFICER IN CHARGE (NCOIC).

- a. Check to see if the mine is dented, cracked, or damaged. If it is, do not use it.
- b. Use the M20 arming wrench to unscrew and remove the arming plug from the mine.

**Performance Steps**

- c. Examine the fuze well for foreign material. If there is foreign material present, turn the mine upside down and gently tap the bottom with your hand to dislodge it. If it cannot be removed, replace the arming plug and do not use the mine.
  - d. Ensure that the booster retainer ring is seated in the fuze well. If the retainer ring is missing, replace the mine.
2. Inspect the fuze.
- a. Remove the M624 fuze from the metal shipping container and inspect it for serviceability.
  - b. Inspect the plastic collar of the fuze by looking down through the top of the pressure ring (Figures 051-192-1105-2 and 051-192-1105-3).

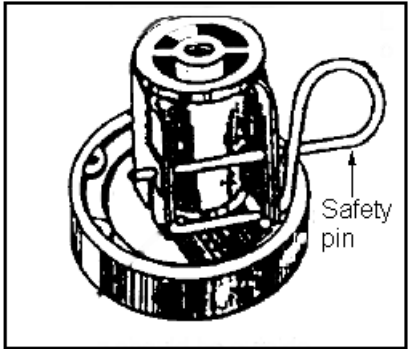

Figure 051-192-1105-2  
Correct safety-pin configuration

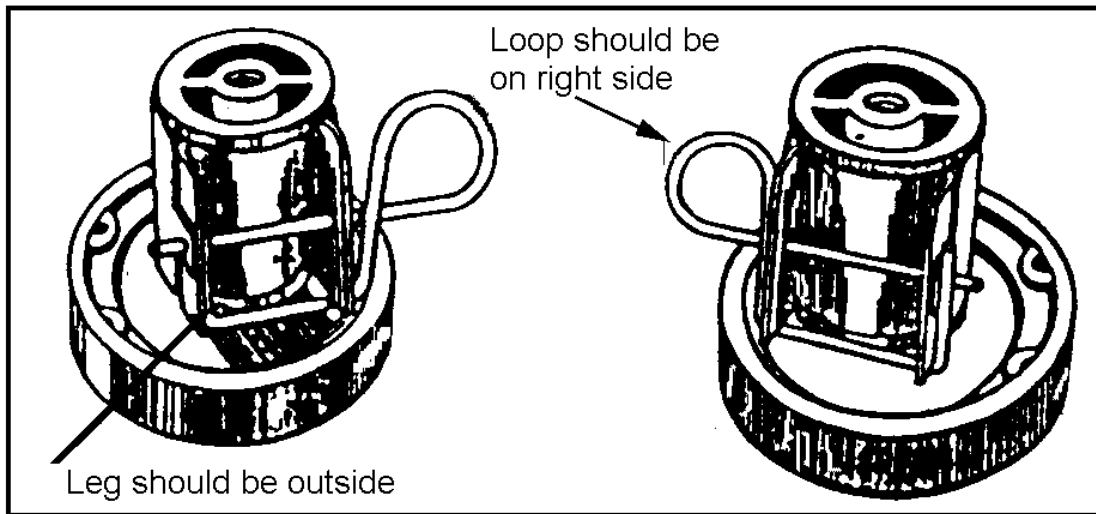

Figure 051-192-1105-3  
Incorrect safety-pin configuration

**CAUTION: IF THE SAFETY PIN IS MISSING OR IMPROPERLY ASSEMBLED, DO NOT USE THE FUZE.**

**CAUTION: DO NOT USE THE FUZE IF THE PLASTIC COLLAR APPEARS TO BE CRACKED.**

### Performance Steps

3. Fuze the mine (Figure 051-192-1105-4).

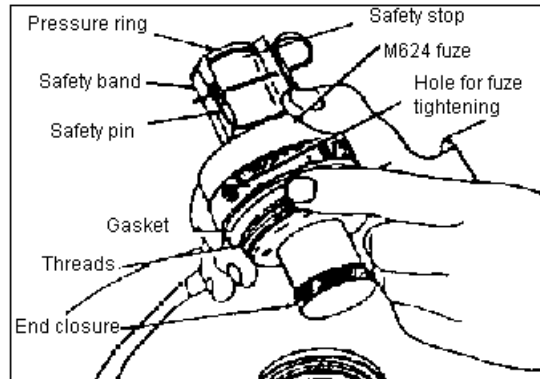

Figure 051-192-1105-4  
Greasing the M624 fuze

NOTE: For long-term emplacement, coat the fuze threads and gasket with silicone grease before removing the end closure.

- a. Unscrew and remove the end closure from the M624 fuze.
- b. Screw the fuze, hand tight, into the threaded fuze well of the M15 AT mine.
- c. Remove the extension rod from its packaging.

NOTE: The M15 AT mine (with the M624 fuze) can be buried or surface laid. If it is surface laid, it must be staked in place.

- d. Tighten the fuze by inserting the unthreaded end of one extension rod piece into the hole on the side of the fuze. Turn the fuze a quarter turn (Figure 051-192-1105-5).

**Performance Steps**

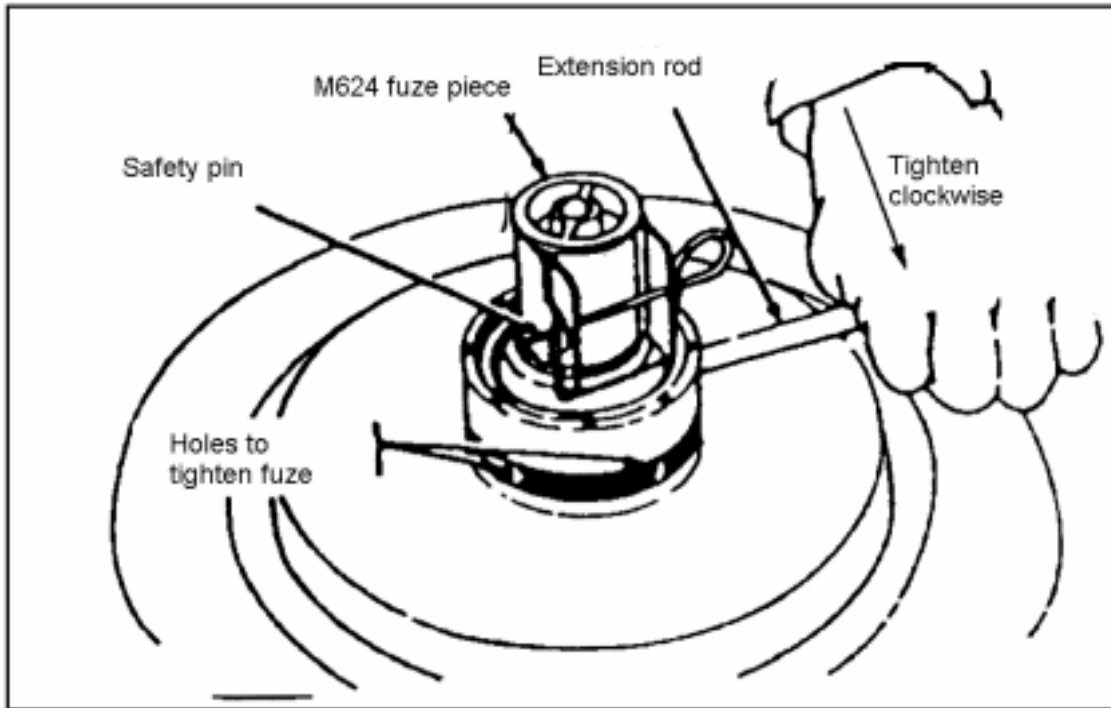

Figure 051-192-1105-5  
Tighten the fuze with the extension rod

- e. Remove the extension rod for further use after the fuze is secure.
- NOTE: The M15 AT mine (with the M624 fuze) can be buried or surface laid. If surface laid, it must be staked in place.
- 4. Dig a hole to fit the mine.
    - a. Dig a hole deep enough so the top of the pressure plate will be at ground level.
    - b. Dig the sides of the hole at a 45-degree angle to prevent vehicles from bridging the mine.
  - 5. Emplace the mine.
    - a. Place the mine in the hole.
    - b. Cover the mine with 2 centimeters (cm) of soil (Figure 051-192-1105-6).

Performance Steps

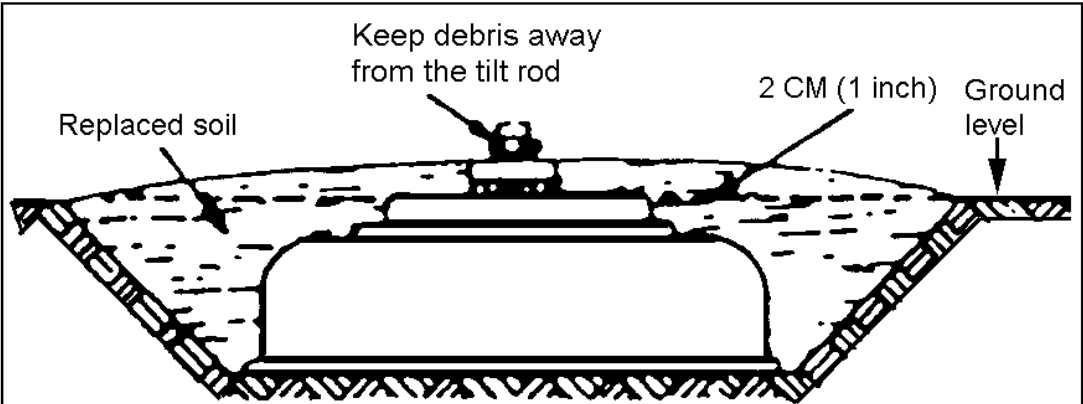

Figure 051-192-1105-6  
M15 AT mine in hole

- c. Assemble all three pieces of the extension rod (mines that uses a tilt rod) (Figure 051-192-1105-7).

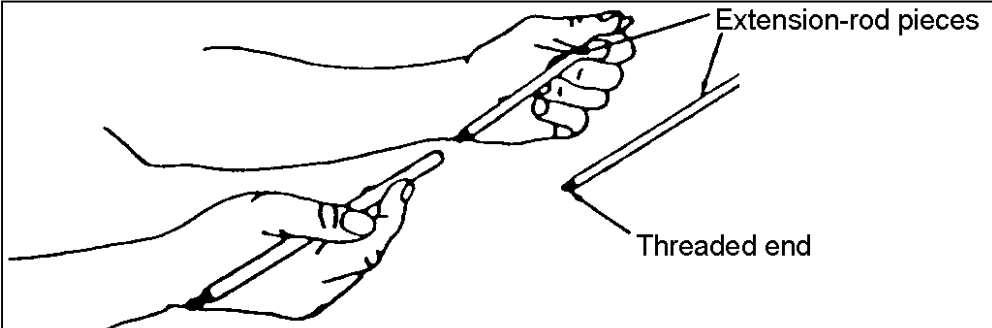

Figure 051-192-1105-7  
Extension-rod assembly

- d. Thread the extension rod into the threaded pressure ring of the fuze (mines that use a tilt rod) (Figure 051-192-1105-8).

**Performance Steps**

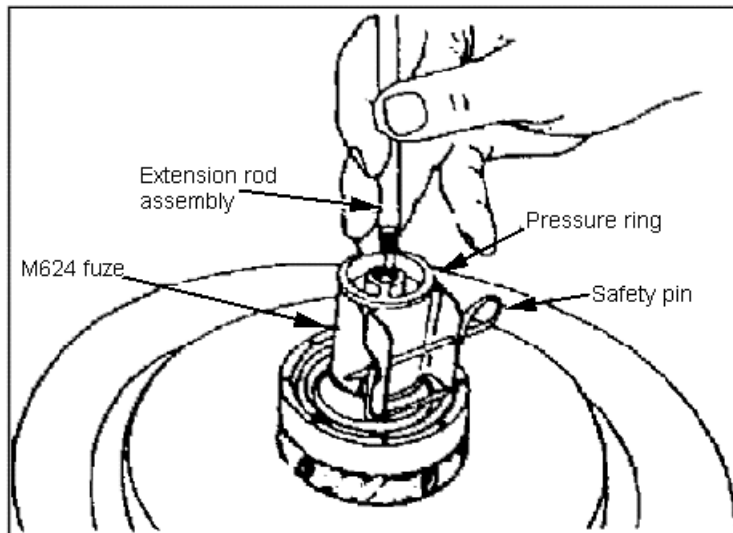

Figure 051-192-1105-8  
Place assembly of the extension rod into the fuze ring

6. Arm the mine.
  - a. Use your right hand to raise the safety pin to the horizontal position. Grasp the safety band and safety stop with your left hand (Figure 051-192-1105-9).

**Performance Steps**

Figure 051-192-1105-9  
Left hand grasping the fuze

- b. Remove the safety pin with your right index finger and pull to the right (Figure 051-192-1105-10).

**Performance Steps**

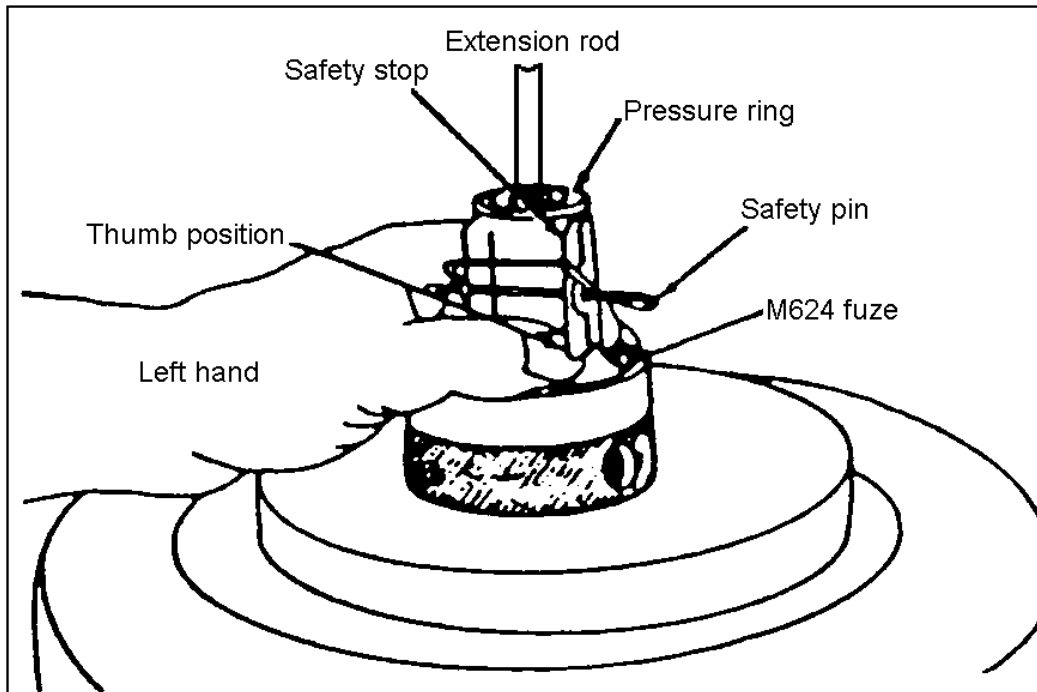
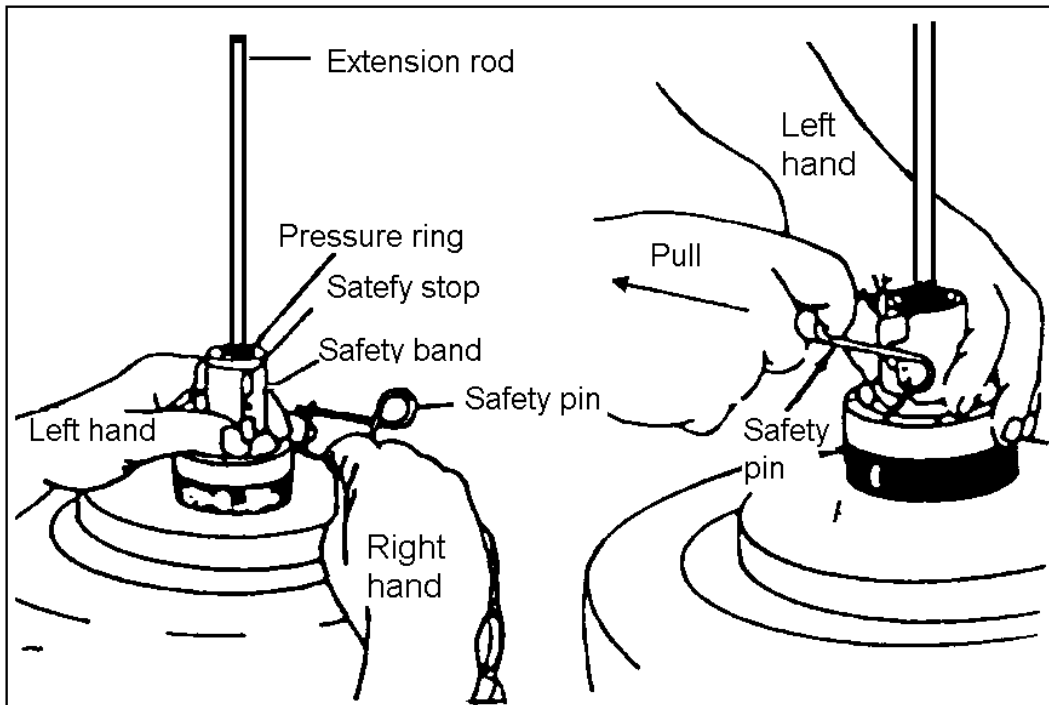

Figure 051-192-1105-10  
Removal of the safety pin

- c. Hold the safety band in place and carefully remove the safety stop (Figure 051-192-1105-11).



**Performance Steps**

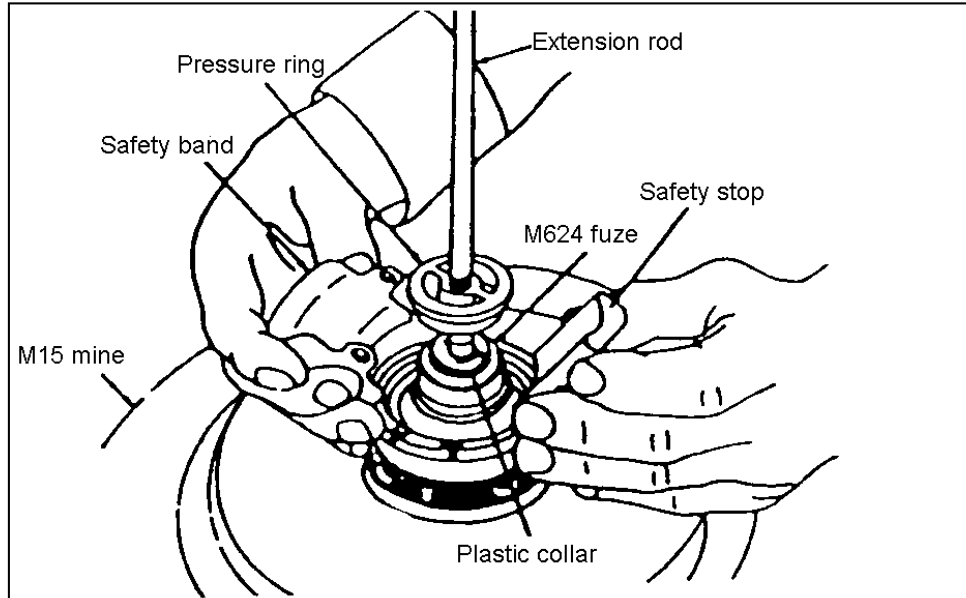

Figure 051-192-1105-11  
 Removing the safety stop and the safety band

- d. Remove the safety band.
- 7. Camouflage the mine.
  - a. Camouflage the mine with twigs, grass, or other material in the area. Place mines with extension rods in tall grass, if possible. Ensure that no pressure is applied to the tilt rod or the fuze.
  - b. Place excess soil in sandbags and remove them from the area.
  - c. Give the band, the stop, the pull-ring assembly, the arming plug, and the end closure to the NCOIC.

**Evaluation Preparation:** Setup: Provide the soldier with the items listed in the conditions. Use inert equipment when performing this task. Brief soldier: Observe the soldier's performance for any improper procedures that may cause the mine to detonate.

**Performance Measures**

**Results**

1. Inspected the mine.	P	F
2. Inspected the fuze.	P	F
3. Fuzed the mine.	P	F
4. Dug a hole to fit the mine.	P	F
5. Emplaced the mine.	P	F
6. Armed the mine.	P	F
7. Camouflaged the mine.	P	F

**Evaluation Guidance:** Score the soldier GO if all steps are passed (P). Score the soldier NO-GO if any step is failed (F). If the soldier fails any step, show him how to do it correctly.

**References**

**Required**

**Related**

FM 20-32

FM 5-34

GTA 5-10-36

GTA 5-10-37

TM 43-0001-36

**REMOVE AN M15 ANTITANK (AT) MINE WITH THE M624 FUZE**  
**051-192-1106**

**Conditions:** As a combat engineer squad member in a field environment, given the location of an emplaced M15 AT mine, and armed with an M624 fuze with a tilt rod, a safety clip, a safety band, a safety stop, and an M20 arming wrench.

**Standards:** Removed an M15 AT mine armed with an M624 fuze, in the proper sequence, without causing the mine to detonate.

**Performance Steps**

**WARNING:** BEFORE ATTEMPTING TO DISARM AND REMOVE THE MINE, CHECK FOR BOOBY TRAPS AND DAMAGE OR MALFUNCTIONS TO THE MINE. IF ANY OF THESE CONDITIONS EXIST, NOTIFY THE NONCOMMISSIONED OFFICER IN CHARGE (NCOIC). DO NOT ATTEMPT TO DISARM THE MINE.

1. Disarm the mine.

**WARNING:** DO NOT APPLY PRESSURE TO THE TILT ROD OR FUZE AT ANY TIME.

- a. Clear the camouflage away from the mine.
- b. Assemble the safety band and safety stop on the fuze so the pressure ring is immobilized (Figure 051-192-1106-1).

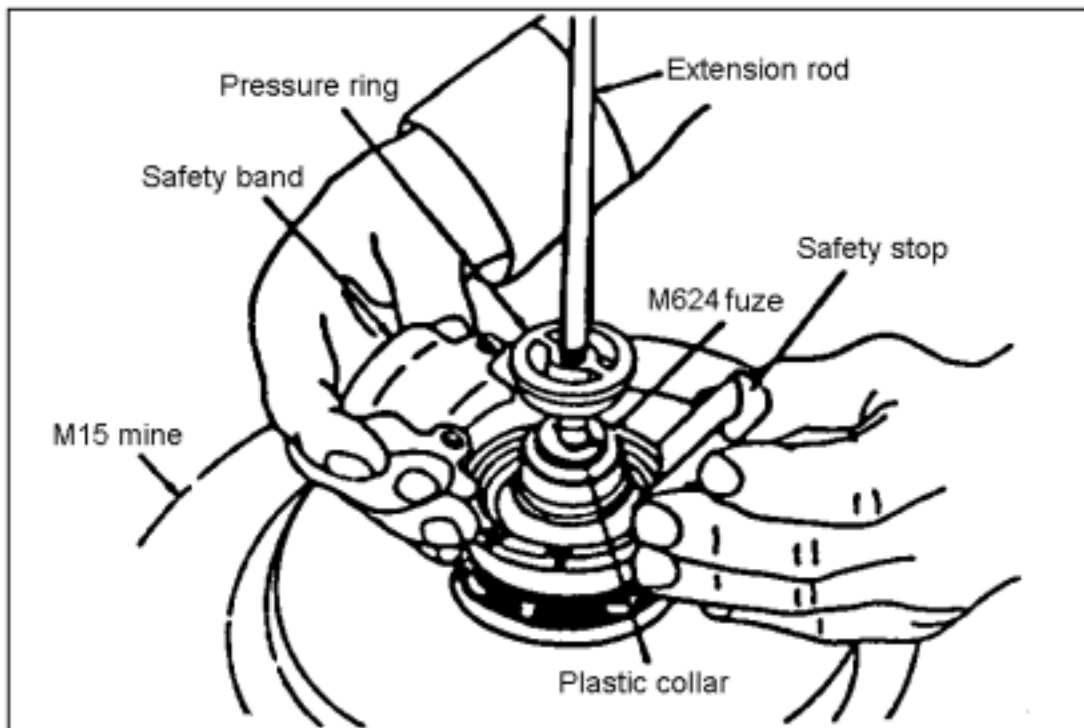

Figure 051-192-1106-1  
 Safety band and safety stop installation

- c. Install the safety pin while holding the safety band and stop (Figure 051-192-1106-2 and Figure 051-192-1106-3).

**Performance Steps**

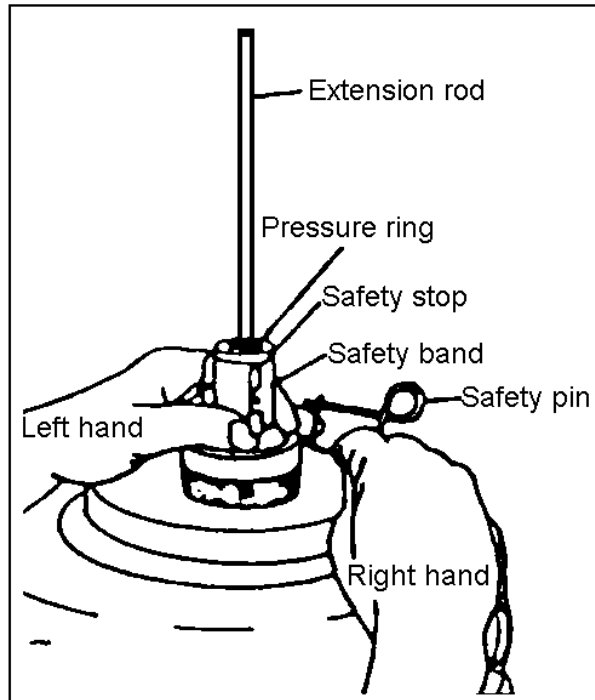

Figure 051-192-1106-2  
Safety pin installation

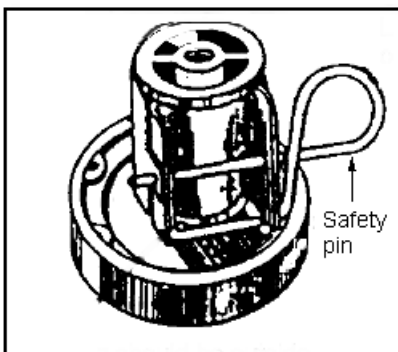

Figure 015-192-1106-3  
Correct safety-pin configuration

NOTE: Ensure that the safety pin is replaced correctly.

d. Unscrew and remove the extension rod.

2. Check for antihandling devices (AHDs).

a. Hold the mine firmly in place with one hand without putting pressure on the fuze.

**Performance Steps**

- b. Feel for AHDs by digging around and underneath the mine with the other hand.
- 3. Remove the mine.
  - a. Remove the mine from the hole.
  - b. Remove the fuze from the mine. Use the extension rod, if necessary.
  - c. Replace the end closure on the fuze.
  - d. Install the arming plug in the fuze well of the mine.

**Evaluation Preparation:** Setup: Provide the soldier with the items listed in the conditions. Use inert equipment when performing this task. Brief soldier: Observe the soldier's performance for any improper procedures that may cause the mine to detonate.

<b>Performance Measures</b>	<b>Results</b>	
1. Disarmed the mine	P	F
2. Checked for AHDs.	P	F
3. Removed the mine	P	F

**Evaluation Guidance:** Score the soldier GO if all steps are passed (P). Score the soldier NO-GO if any step is failed (F). If the soldier fails any step, show him how to do it correctly.

**References**

**Required**

**Related**

- FM 20-32
- FM 5-34
- TM 43-0001-36

**INSTALL AN M15 ANTITANK (AT) MINE USING THE M603 FUZE  
051-192-1107**

**Conditions:** As a combat engineer squad member in a field environment, given an M15 AT mine, an M603 fuze, an M20 arming wrench, G697 silicone grease, sandbags, and an entrenching tool.

**Standards:** Installed an M15 AT mine with an M603 fuze, in the proper sequence, without causing the mine to detonate.

**Performance Steps**

1. Inspect the mine.

**CAUTION:** IF THERE IS A PROBLEM IN ANY OF THE FOLLOWING STEPS, NOTIFY THE NONCOMMISSIONED OFFICER IN CHARGE (NCOIC).

- a. Check to see if the mine is dented, cracked, or damaged. If it is, do not use it.
- b. Use the M20 wrench, if needed, to unscrew and remove the arming plug from the mine (Figure 051-192-1107-1).

## Performance Steps

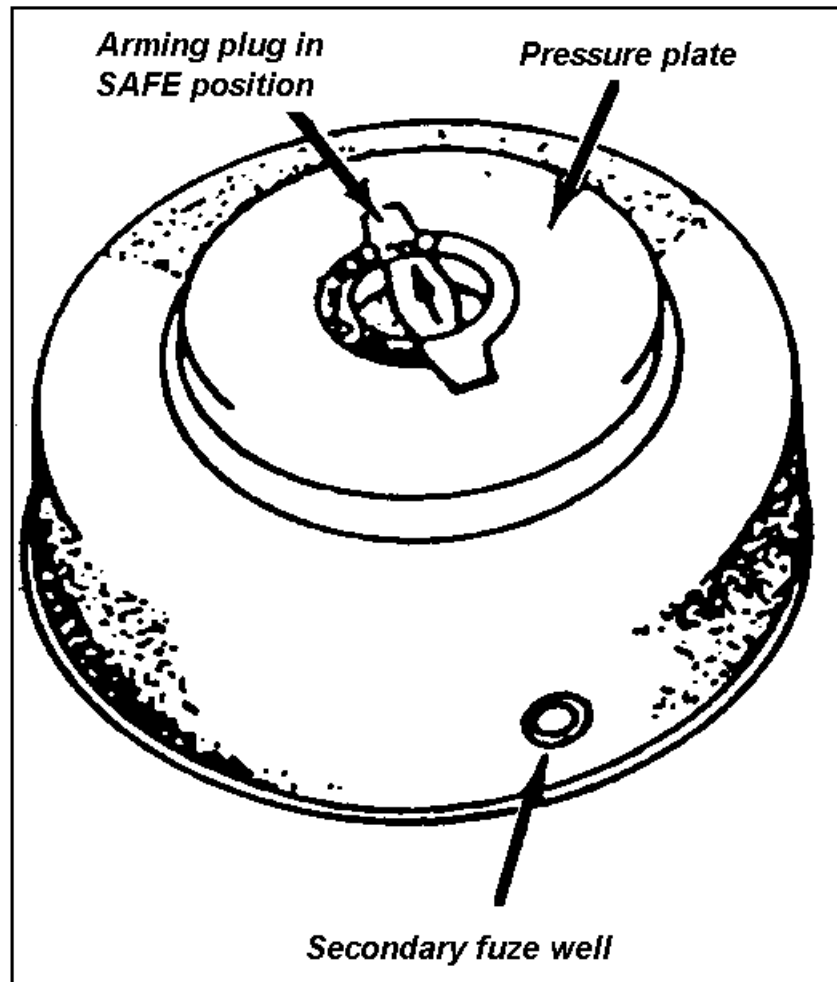

Figure 051-192-1107-1  
M15 AT mine

- c. Examine the fuze well for foreign material. If foreign material is present, remove it by turning the mine upside down and lightly shaking the mine.

NOTE: If the material cannot be removed, replace the arming plug and do not use the mine.

- d. Ensure that the booster-retainer ring is seated in the fuze well. If the retainer ring is missing, replace the mine.

2. Perform a function check with the arming plug.

- a. Turn the setting knob to the ARMED position. Ensure that the shutter bar moves across the bottom of the arming plug (Figure 051-192-1107-2).

**Performance Steps**

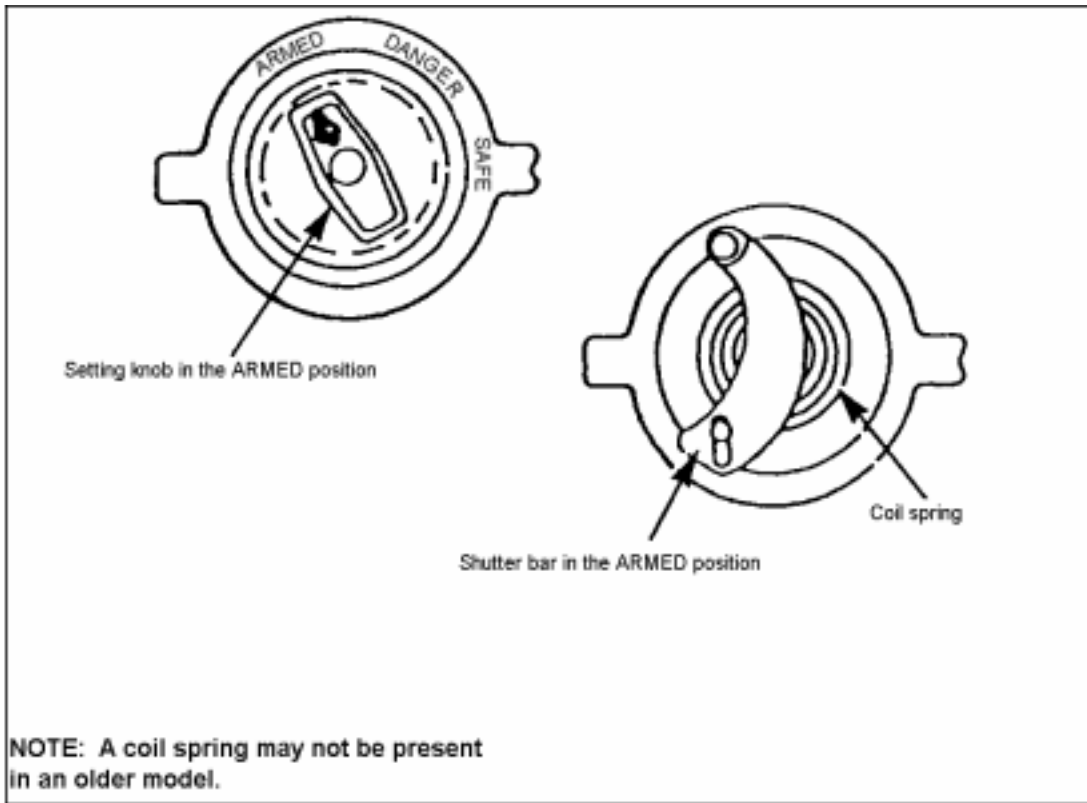

Figure 051-192-1107-2  
ARMED position

- b. Turn the setting knob to the SAFE position. Ensure that the shutter bar moves back across the bottom of the arming plug (Figure 051-192-1107-3).

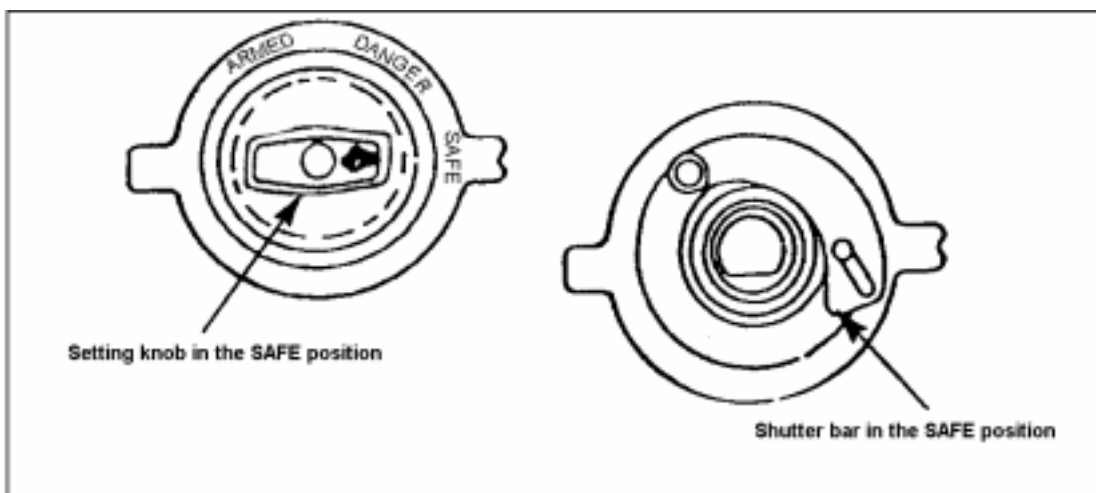

Figure 051-192-1107-3  
SAFE position



**Performance Steps**

NOTE: If the shutter bar does not go into the SAFE or ARMED position, notify the NCOIC.

## 3. Fuze the mine.

CAUTION: ENSURE THAT THE SAFETY FORK MOVES FREELY. IF THERE IS PRESSURE ON THE FORK, DO NOT REMOVE IT AND NOTIFY THE NCOIC.

- a. Remove the M603 fuze from its metal shipping container and inspect it for damage. The varnish or painted lining must show on the bottom of the fuze.

NOTE: For long-term emplacement, coat the fuze with silicone grease G697. Also, smear grease on the threads and walls of the fuze well.

- b. Use the hooked end of the M20 wrench to remove the safety fork of the M603 fuze. Retain the safety fork for future use (Figure 051-192-1107-4).

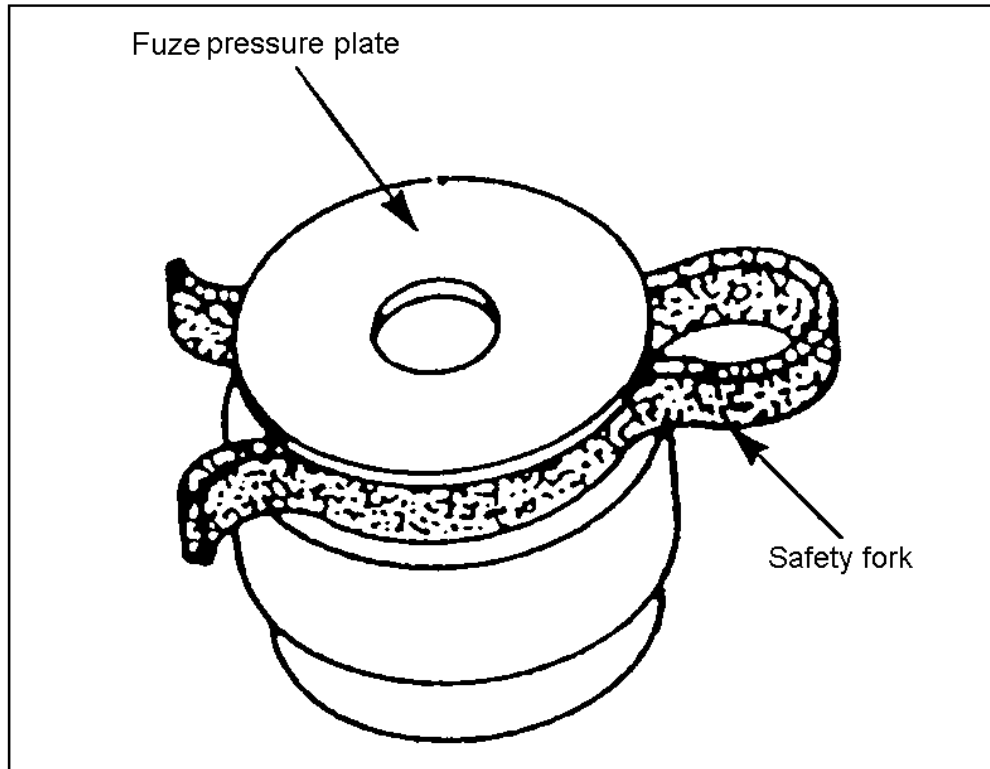

Figure 051-192-1107-4  
Safety fork

WARNING: DO NOT APPLY PRESSURE TO THE PRESSURE PLATE OF THE FUZE AT ANY TIME.

- c. Insert the fuze into the fuze well until it seats securely on top of the booster retaining ring.
- d. Use the M20 arming wrench to perform a clearance test (Figure 051-192-1107-5). Insert the tab end of the arming wrench into the fuze well and move it back and forth to ensure that the tab end does not touch the fuze.

**Performance Steps**

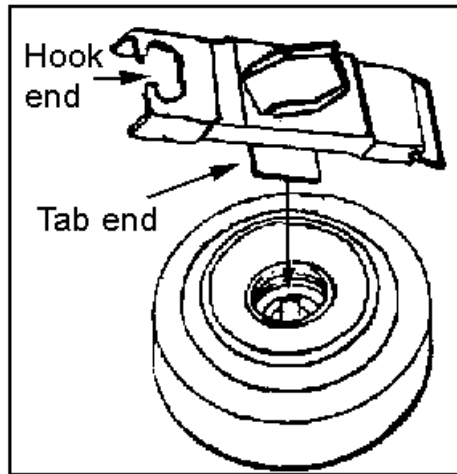

Figure 051-192-1107-5  
Fuze clearance check

**WARNING: IF THE FUZE PRESSURE PLATE INTERFERES WITH THE TAB END OF THE M20 ARMING WRENCH, INVESTIGATE THE CAUSE AND NOTIFY THE NCOIC. DO NOT ARM THE MINE.**

4. Install the arming plug.

**NOTE:** For long-term emplacement, smear silicone grease G697 on the threads, the gasket, and the shutter on the underside of the arming plug.

- a. Ensure that the setting knob is in the SAFE (S) position.
- b. Screw the arming plug into the mine by hand. Ensure that there is a watertight seal by using the M20 arming wrench to tighten the arming plug.

5. Dig a hole deep enough to fit the mine.

- a. Dig a hole deep enough so that when the mine is placed into it, the top of the pressure plate will be about 1 1/2 inches below ground level.
- b. Dig the sides of the hole at a 45-degree angle to prevent vehicles from bridging the mine (Figure 051-192-1107-6).

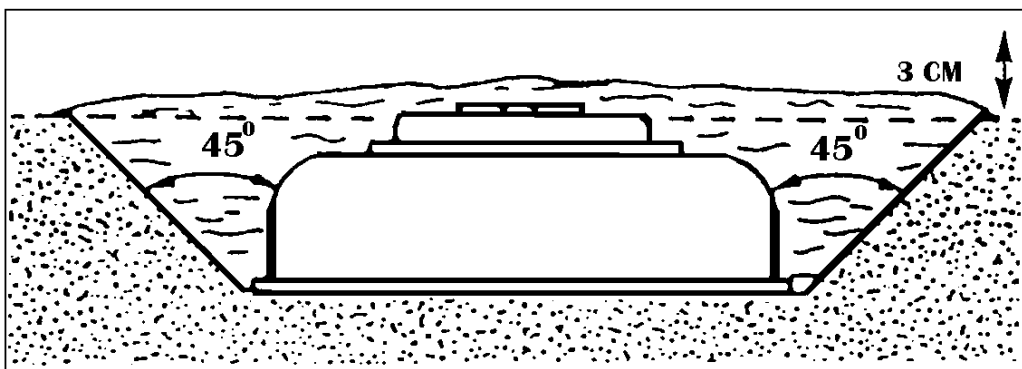

Figure 051-192-1107-6  
M15 AT mine in the hole

6. Emplace the mine.

- a. Put the mine in the hole.

**Performance Steps**

- b. Cover the mine with soil until it is level with the top of the pressure plate.
- 7. Use the M20 arming wrench to arm the mine. Turn the setting knob from the SAFE (S) to the ARMED (A) position.
- 8. Camouflage the mine.
  - a. Cover the mine with 1 to 2 inches of soil.
  - b. Camouflage the mine. Place the excess soil in sandbags and remove them from the area.
  - c. Give the safety fork to the NCOIC.

**Evaluation Preparation:** Setup: Provide the soldier with the items listed in the conditions. Use inert equipment when performing this task. Brief soldier: Observe the soldier's performance for any improper procedures that may cause the mine to detonate.

<b>Performance Measures</b>	<b>Results</b>	
1. Inspected the mine.	P	F
2. Performed a function check with the arming plug.	P	F
3. Fuzed the mine.	P	F
4. Installed the arming plug.	P	F
5. Dug a hole deep enough to fit the mine.	P	F
6. Emplaced the mine.	P	F
7. Used the M20 wrench to arm the mine.	P	F
8. Camouflaged the mine.	P	F

**Evaluation Guidance:** Score the soldier GO if all steps are passed (P). Score the soldier NO-GO if any step is failed (F). If the soldier fails any step, show him how to do it correctly.

**References**

**Required**

**Related**

- FM 20-32
- FM 5-34
- TM 43-0001-36

**REMOVE AN M15 ANTITANK (AT) MINE WITH THE M603 FUZE**  
**051-192-1108**

**Conditions:** As a combat engineer squad member in a field environment, given the location of an emplaced M15 AT mine armed with an M603 fuze, a safety fork, and an M20 arming wrench.

**Standards:** Removed an M15 AT mine armed with an M603 fuze, in the proper sequence, without causing the mine to detonate.

**Performance Steps**

**WARNING: BEFORE ATTEMPTING TO DISARM AND REMOVE THE MINE, CHECK FOR BOOBY TRAPS AND DAMAGE OR MALFUNCTIONS TO THE MINE. IF ANY OF THESE CONDITIONS EXIST, STOP AND NOTIFY THE NONCOMMISSIONED OFFICER IN CHARGE (NCOIC). DO NOT ATTEMPT TO DISARM THE MINE.**

1. Disarm the mine.

**WARNING: DO NOT APPLY PRESSURE TO THE PRESSURE PLATE AT ANY TIME.**

- a. Clear the soil from the top of the mine.
- b. Hold the mine firmly in place with one hand. Do not put pressure on the pressure plate.
- c. Feel for antihandling devices (AHDs), with the other hand, by digging around the sides and underneath the mine.

**WARNING: IF YOU FIND AN AHD, STOP AND NOTIFY THE NCOIC. DO NOT REMOVE THE MINE.**

- d. Use the M20 arming wrench to turn the setting knob to the SAFE (S) position (Figure 051-192-1108-1).

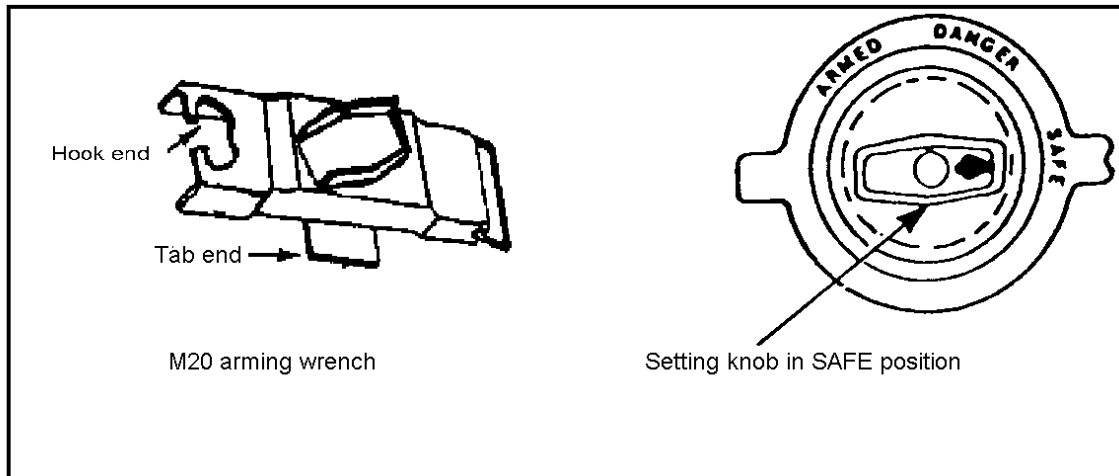

Figure 051-192-1108-1  
M20 arming wrench and the setting knob

**WARNING: IF THE SETTING KNOB IS DIFFICULT TO TURN, STOP; DO NOT FORCE IT. NOTIFY THE NCOIC.**

2. Remove the mine

- a. Remove the mine from the hole.
- b. Use the M20 arming wrench to turn the arming plug counterclockwise to remove the plug.
- c. Remove the M603 fuze from the fuze well and replace the safety fork on the fuze.
- d. Install the arming plug.

**Evaluation Preparation:** Setup: Provide the soldier with the items listed in the conditions. Use inert equipment when performing this task. Brief soldier: Observe the soldier's performance for any improper procedures that may cause the mine to detonate.

<b>Performance Measures</b>	<b>Results</b>
1. Disarmed the mine.	P    F
2. Removed the mine.	P    F

**Evaluation Guidance:** Score the soldier GO if all steps are passed (P). Score the soldier NO-GO if any step is failed (F). If the soldier fails any step, show him how to do it correctly.

**References**  
**Required**

- Related**  
 FM 20-32  
 FM 5-34  
 GTA 5-10-36  
 GTA 5-10-37  
 TM 43-0001-36

## INSTALL AN M19 ANTITANK (AT) MINE

051-192-1109

**Conditions:** As a combat engineer squad member in a field environment, given an M19 AT mine, an M50 detonator, an M22 arming wrench, an entrenching tool, G697 silicone grease, and sandbags.

**Standards:** Installed an M19 AT mine, in the proper sequence, without detonating the mine.

### Performance Steps

1. Inspect the mine.

**CAUTION:** IF THERE IS A PROBLEM IN ANY OF THE FOLLOWING STEPS, NOTIFY THE NONCOMMISSIONED OFFICER IN CHARGE (NCOIC).

- a. Check to see if the mine is dented, cracked, or damaged. If it is, do not use it.
- b. Use the M22 wrench to remove the M606 fuze from the fuze well by turning it counterclockwise a quarter turn (Figures 051-192-1109-1 and 051-192-1109-2).

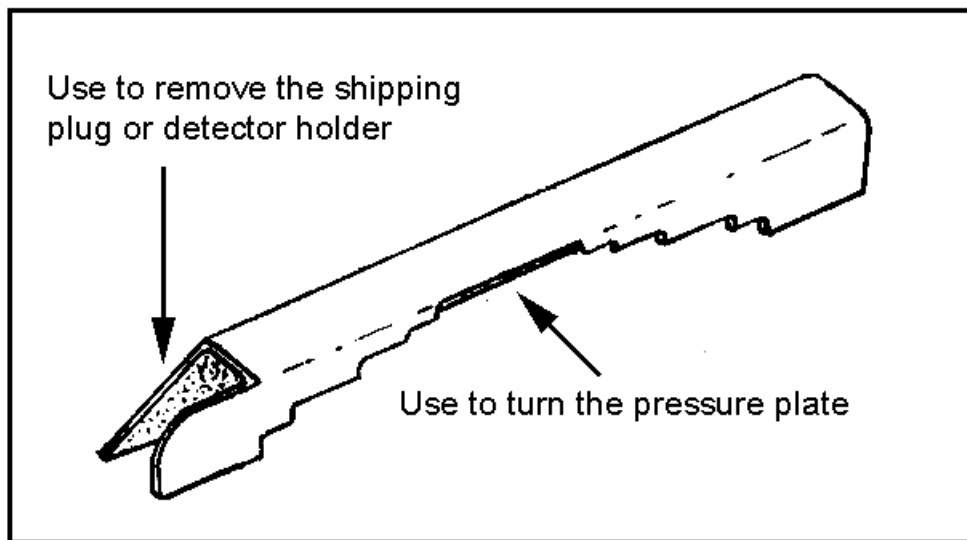

Figure 051-192-1109-1  
M22 arming wrench

## Performance Steps

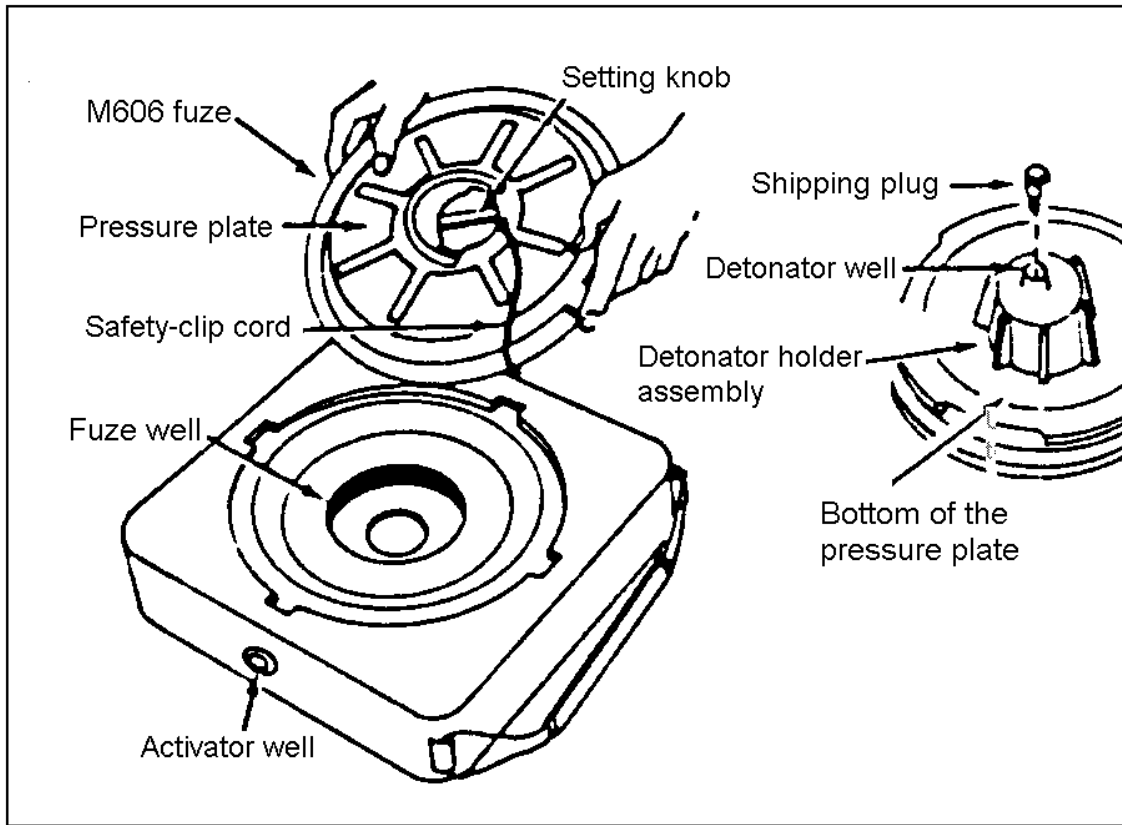

Figure 051-192-1109-2  
Pressure plate removal

- c. Ensure that the rubber gasket is on the M606 fuze.
- d. Remove any foreign material that is found in the fuze well.
- e. Ensure that the setting knob is in the SAFE (S) position and the safety clip is in place.
- f. Use the M22 wrench, if needed, to remove the shipping plug from the detonator well. Retain the shipping plug.
- g. Examine the detonator well for foreign material. If foreign material is present, remove it by turning the fuze upside down and tapping it lightly on the side.

NOTE: The activator well is to be used with the M142 multipurpose firing device.

2. Test the firing pin's position (Figure 051-192-1109-3).

## Performance Steps

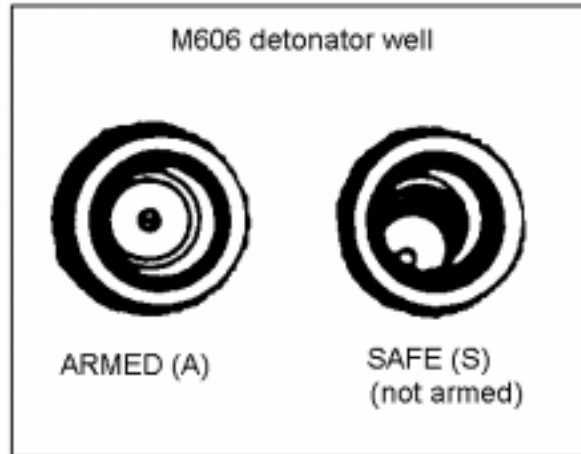

Figure 051-192-1109-3  
Firing pin positions

**WARNING: DO NOT ADJUST THE SETTING KNOB WHILE THE DETONATOR IS IN THE DETONATOR WELL.**

- a. Look at the firing pin's position. Ensure that the firing pin is at the edge of the well when the setting knob is in the SAFE (S) position.

**NOTE:** If the pin is in the middle of the well, notify the NCOIC.

- b. Remove the safety clip.
- c. Use the M22 wrench to turn the setting knob to the ARMED (A) position. Ensure that the firing pin is in the center of the well.
- d. Use the M22 wrench to turn the setting knob back to the SAFE (S) position. Ensure that the firing pin moves back to the side of the well.

**NOTE:** If the firing pin is not in the correct position when the setting knob is in either the ARMED (A) or SAFE (S) position, notify the NCOIC.

- e. Replace the safety clip.

3. Place the M50 detonator into the detonator well.

**NOTE:** For long-term emplacement, smear G697 silicone grease on the top of the detonator, the detonator holder, and the threaded portion of the detonator holder.

4. Use the M22 wrench to tighten the M606 fuze into the fuze well.

**NOTE:** For long term emplacement, smear G697 silicone grease on the fuze gasket.

5. Dig a hole to fit the mine.

- a. Dig a hole deep enough so the top of the pressure plate will be even or slightly below ground level.
- b. Dig the sides of the hole at a 45-degree angle to prevent vehicles from bridging the mine.

6. Emplace the mine.

- a. Put the mine in the hole.



**Performance Steps**

- b. Cover the mine with soil until it is level with the top of the pressure plate, leaving the setting knob exposed.
- 7. Arm the mine.
  - a. Remove the safety clip.
  - b. Use the M22 wrench to turn the setting knob from the SAFE (S) to the ARMED (A) position.
- 8. Camouflage the mine.
  - a. Cover the mine with 1 to 2 inches of soil.
  - b. Camouflage the mine. Place the excess soil in sandbags and remove them from the area.
  - c. Give the safety clip and shipping plug to the NCOIC.

**Evaluation Preparation:** Setup: Provide the soldier with the items listed in the conditions. Use inert equipment when performing this task. Brief soldier: Observe the soldier's performance for any improper procedures that may cause the mine to detonate.

**Performance Measures**

**Results**

1. Inspected the mine.	P	F
2. Tested the firing pin's position.	P	F
3. Placed the M50 detonator into the detonator well.	P	F
4. Used the M22 wrench to tighten the M606 fuze into the fuze well.	P	F
5. Dug a hole to fit the mine.	P	F
6. Emplaced the mine.	P	F
7. Armed the mine.	P	F
8. Camouflaged the mine.	P	F

**Evaluation Guidance:** Score the soldier GO if all steps are passed (P). Score the soldier NO-GO if any step is failed (F). If the soldier fails any step, show him how to do it correctly.

**References**

**Required**

**Related**

FM 20-32  
 FM 5-34  
 GTA 5-10-36  
 GTA 5-10-37  
 TM 43-0001-36

## REMOVE AN M19 ANTITANK (AT) MINE

**051-192-1110**

**Conditions:** As a combat engineer squad member in a field environment, given the location of an emplaced M19 AT mine, an M22 arming wrench, a safety clip, and a shipping plug.

**Standards:** Removed an M19 AT mine, in the proper sequence, without causing the mine to detonate.

### Performance Steps

**WARNING:** BEFORE ATTEMPTING TO DISARM AND REMOVE THE MINE, CHECK FOR BOOBY TRAPS, DAMAGE, OR MALFUNCTIONS. IF ANY OF THESE CONDITIONS EXIST, NOTIFY THE NONCOMMISSIONED OFFICER IN CHARGE (NCOIC). DO NOT ATTEMPT TO DISARM THE MINE.

1. Disarm the mine.

**WARNING:** DO NOT APPLY PRESSURE TO THE PRESSURE PLATE AT ANY TIME.

- a. Clear the soil from the top of the mine.
- b. Hold the mine firmly in place with one hand. Do not put pressure on the pressure plate.
- c. Feel for antihandling devices (AHDs), with the other hand, by digging around the sides and underneath the mine.

**WARNING:** IF YOU FIND AN AHD, STOP AND NOTIFY THE NCOIC. DO NOT REMOVE THE MINE.

- d. Use the M22 wrench to turn the setting knob to the SAFE (S) position.

**WARNING:** IF THE SETTING KNOB IS DIFFICULT TO TURN, DO NOT FORCE IT. NOTIFY THE NCOIC.

- e. Replace the safety clip on the M606 fuze.

2. Remove the mine.

- a. Remove the mine from the hole.
- b. Use the M22 wrench to remove the M606 fuze. Turn the wrench counterclockwise and lift the fuze out of the fuze well.
- c. Remove the detonator holder assembly from the well.
- d. Replace the shipping plug in the detonator well.
- e. Replace the pressure plate in the mine.

**Evaluation Preparation:** Setup: Provide the soldier with the items listed in the conditions. Use inert equipment when performing this task. Brief soldier: Observe the soldier's performance for any improper procedures that may cause the mine to detonate.

### Performance Measures

### Results

- |                       |   |   |
|-----------------------|---|---|
| 1. Disarmed the mine. | P | F |
| 2. Removed the mine.  | P | F |

**Evaluation Guidance:** Score the soldier GO if all steps are passed (P). Score the soldier NO-GO if any step is failed (F). If the soldier fails any step, show him how to do it correctly.

### References

#### Required

#### Related

FM 20-32  
 FM 5-34  
 GTA 5-10-36  
 GTA 5-10-37  
 TM 43-0001-36

**INSTALL AN M21 ANTITANK (AT) MINE**  
**051-192-1117**

**Conditions:** As a combat engineer squad member in a field environment, given a M21 AT mine, a M120 booster, a M607 fuze, a M26 arming wrench, an entrenching tool, G697 silicone grease, and sandbags.

**Standards:** Installed a M21 AT mine, in the proper sequence, without causing the mine to detonate.

**Performance Steps**

1. Inspect the mine and components.

**CAUTION:** IF THERE IS A PROBLEM IN ANY OF THE FOLLOWING STEPS, NOTIFY THE NONCOMMISSIONED OFFICER IN CHARGE (NCOIC).

- a. Check to see if the mine is dented, cracked, or damaged. If it is, do not use it.
- b. Ensure that the cotter pin of the fuze pull-ring assembly and fuze closure assembly are securely in place (Figure 051-192-1117-1).

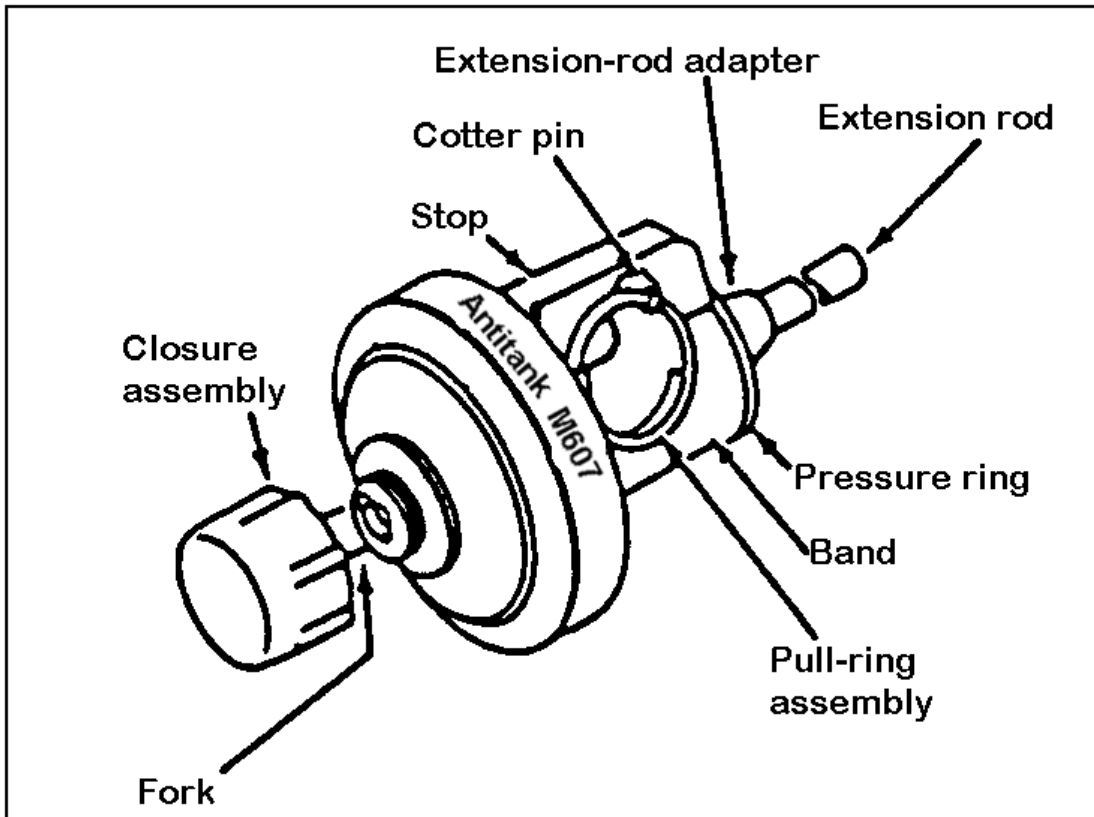

Figure 051-192-1117-1  
M607 fuze

- c. Turn the safety band and stop and look at the top of the fuze (Figure 051-192-1117-1).

**CAUTION:** IF THE TOP OF THE FUZE TURNS WITH THE STOP AND BAND, THE NECK OF THE FUZE IS BROKEN.

2. Insert the booster.

- a. Turn the mine upside down. Use the screwdriver end of the M26 wrench to remove the closing plug from the bottom of the mine by turning the plug counterclockwise (Figure 051-192-1117-2).

**Performance Steps**

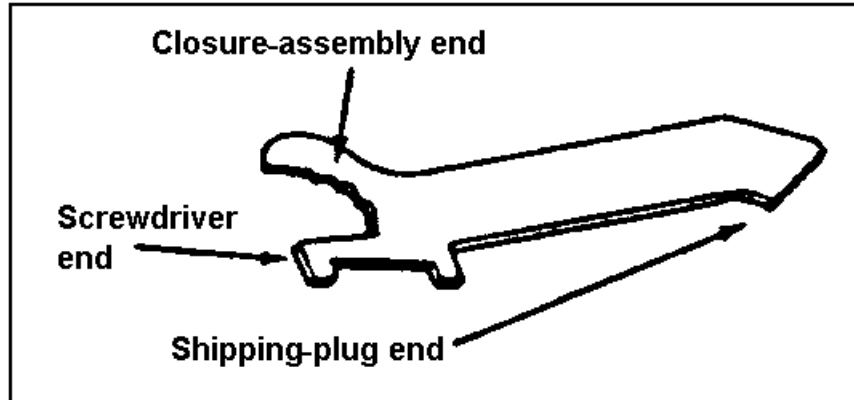

Figure 051-192-1117-2  
M26 wrench

- b. Examine the booster well for foreign material. If foreign material is present, gently tap the side of the mine with your hand to dislodge it.

**CAUTION: IF THE FOREIGN MATERIAL CANNOT BE REMOVED, REPLACE THE CLOSING PLUG. DO NOT USE THE MINE.**

- c. Insert the M120 booster, with the washer side toward the fuze, into the booster well.
- d. Use the M26 wrench to replace the closure plug, with the gasket side toward the booster, and turn clockwise.

**NOTE:** For long-term emplacement, smear G697 silicone grease on the threads of the closing-plug assembly.

3. Fuze the mine.
  - a. Turn the mine over. Use the M26 wrench to remove the shipping plug from the fuze well on top of the mine (Figure 051-192-1117-3).

## Performance Steps

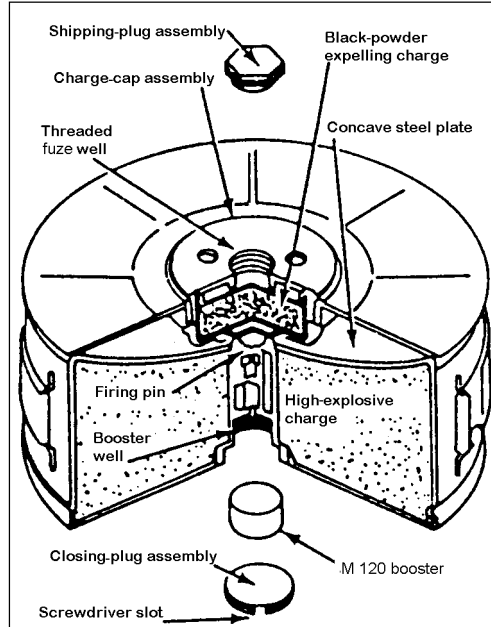

Figure 051-192-1117-3  
View of M21 AT mine

- b. Examine the fuze well for foreign material. If foreign material is present, gently shake the mine to dislodge it.

**CAUTION: IF FOREIGN MATERIAL CANNOT BE REMOVED, DO NOT USE THE MINE.**

- c. Use the M26 wrench to remove the closure assembly from the M607 fuze. Ensure that the gasket remains in place on the fuze.

- d. Screw the fuze, hand tight, into the fuze well and set the mine to the side.

**NOTE:** For long-term emplacement, smear G697 silicone grease on the fuze threads.

4. Dig a hole to fit the mine.

**NOTE:** Mines with extension rods should be placed in tall grass, if possible.

- a. Dig a hole deep enough so the top of the mine will be at ground level (Figure 051-192-1117-4).

**Performance Steps**

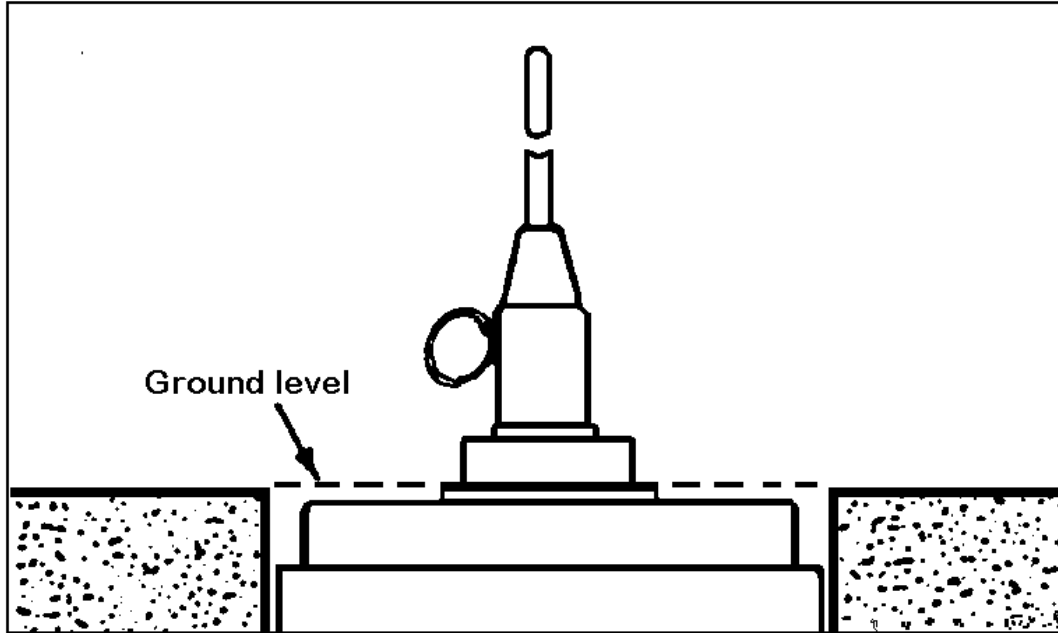

Figure 051-192-1117-4  
M21 AT mine in a hole

- b. Check the bottom of the hole to ensure that the ground is solid enough to support the mine. If necessary, place a flat object under the mine to provide a firm foundation. Allow additional depth for the object.

5. Emplace the mine.

- a. Put the mine in the hole.
- b. Cover the mine with soil until it is level with the top of the mine.
- c. Press the soil firmly around the sides of the mine.

NOTE: Ensure that no soil falls around or under the plastic collar.

6. Assemble the extension rod.

- a. Assemble the three pieces of the extension rod.
- b. Screw the extension rod on the M607 fuze.

WARNING: DO NOT TILT THE EXTENSION ROD. A 20-DEGREE TILT OF THE EXTENTION ROD WILL DETONATE THE MINE.

7. Arm the mine.

- a. Squeeze the end of the cotter pin together on the pull ring (Figure 051-192-1117-5).
- b. Remove the cotter pin by holding the fuze firmly in one hand and pulling on the pull ring with the other hand (Figure 051-192-1117-5).

Performance Steps

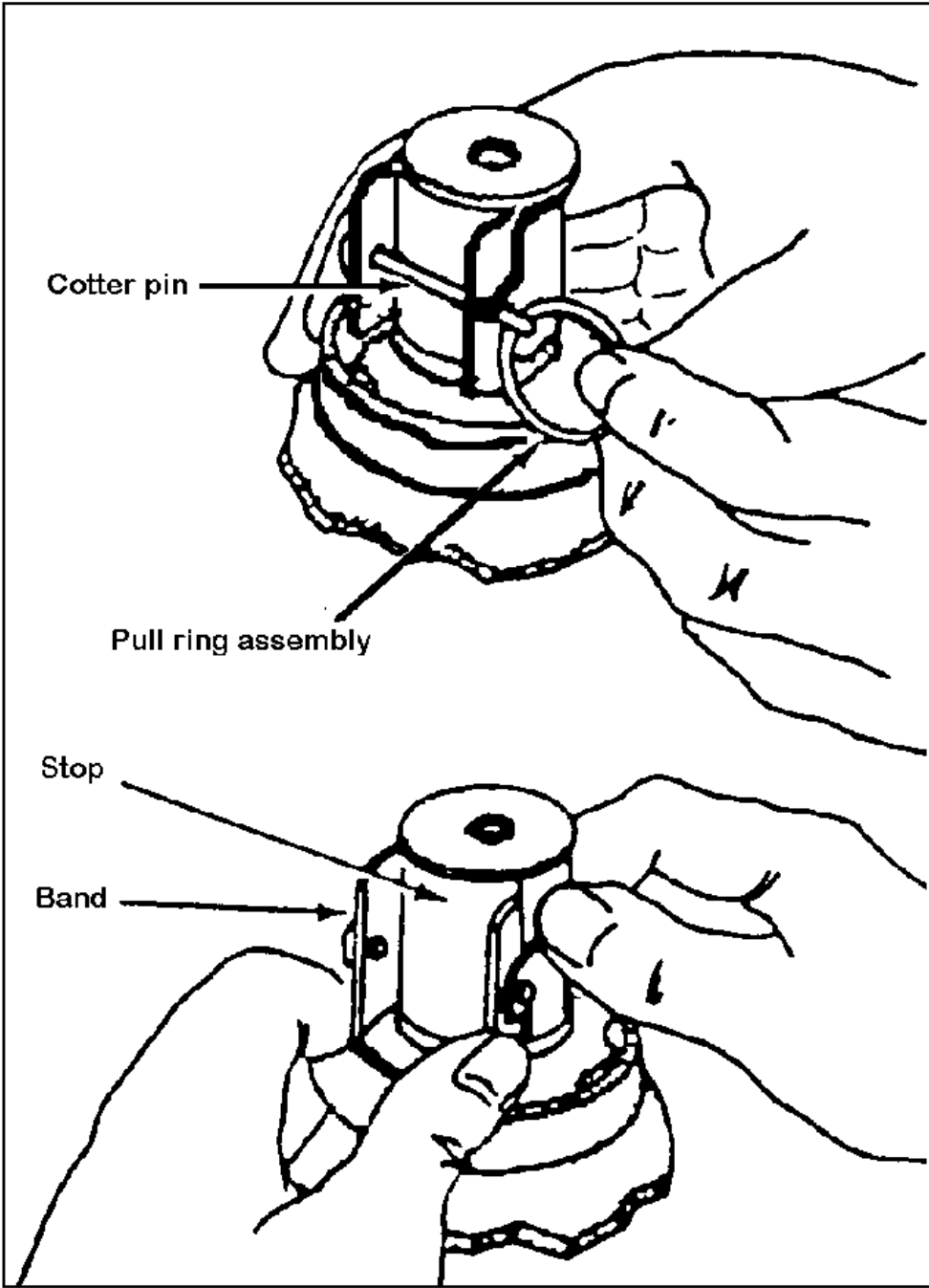

Figure 051-192-1117-5  
Removal of a cotter pin and safety stop

- c. Remove the safety stop and safety band from the fuze slowly and carefully (refer to Figure 051-192-1117-5).

**Performance Steps**

8. Camouflage the mine.
  - a. Add twigs, grass, or other materials to make the area look natural. Ensure that no pressure is applied to the tilt rod or the fuze.
  - b. Place the excess soil in sandbags and remove it from the area.
  - c. Give the band and stop, pull-ring assembly, the shipping plugs, and the closure assembly to the NCOIC.

**Evaluation Preparation:** Setup: Provide the soldier with the items listed in the conditions. Use inert equipment when performing this task. Brief soldier: Observe the soldier's performance for any improper procedures that may cause the mine to detonate.

<b>Performance Measures</b>	<b>Results</b>	
1. Inspected the mine and components.	P	F
2. Inserted the booster.	P	F
3. Fuzed the mine.	P	F
4. Dug a hole to fit the mine.	P	F
5. Emplaced the mine.	P	F
6. Assembled the extension rod.	P	F
7. Armed the mine.	P	F
8. Camouflaged the mine.	P	F

**Evaluation Guidance:** Score the soldier GO if all steps are passed (P). Score the soldier NO-GO if any step is failed (F). If the soldier fails any step, show him how to do it correctly.

**References**

**Required**

**Related**

- FM 5-34
- GTA 5-10-36
- GTA 5-10-37
- TM 43-0001-36



**REMOVE AN M21 ANTITANK (AT) MINE****051-192-1118**

**Conditions:** As a combat engineer squad member in a field environment, given the location of an enplaced M21 AT mine, an M26 arming wrench, the band and the stop, cotter pins, a shipping plug, and a closure assembly.

**Standards:** Removed an M21 AT mine, in the proper sequence, without causing the mine to detonate.

**Performance Steps**

**WARNING:** BEFORE ATTEMPTING TO DISARM AND REMOVE THE MINE, CHECK FOR BOOBY TRAPS, DAMAGE, OR MALFUNCTIONS TO THE MINE. IF ANY OF THESE CONDITIONS EXIST, NOTIFY THE NONCOMMISSIONED OFFICER IN CHARGE (NCOIC). DO NOT ATTEMPT TO DISARM THE MINE.

1. Disarm the mine.

**WARNING:** DO NOT APPLY PRESSURE TO THE TILT ROD OR FUZE AT ANY TIME.

- a. Clear the camouflage away from the mine.
- b. Attach the band and the stop to the fuze (Figure 051-192-1118-1).

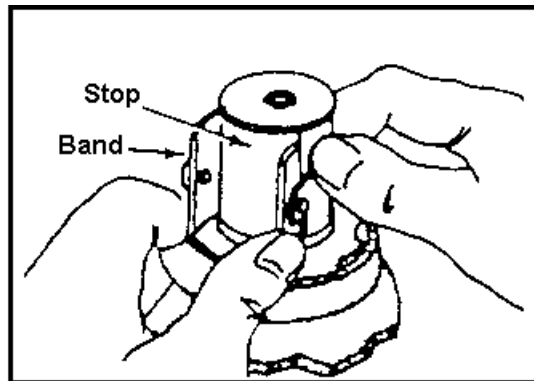

Figure 051-192-1118-1  
Attaching the band and the stop

- c. Insert the cotter pin into the band and the stop. Spread the ends of the cotter pin (Figure 051-192-1118-2).

**Performance Steps**

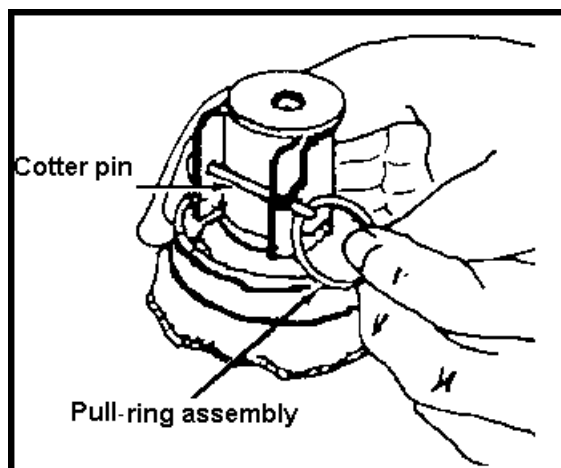

Figure 051-192-1118-2  
Inserting the cotter pin

- d. Unscrew and remove the extension rod.
  - 2. Check for antihandling devices (AHDs).
    - a. Hold the mine firmly in place with one hand. Do not put pressure on the fuze.
    - b. Feel for AHDs, with the other hand, by digging around the sides and underneath the mine.
- WARNING: IF YOU FIND AN AHD, STOP AND NOTIFY THE NCOIC. DO NOT REMOVE THE MINE.**
- 3. Remove the mine.
    - a. Remove the mine from the hole.
    - b. Remove the fuze from the mine.
    - c. Install the closure assembly on the fuze.
    - d. Install the shipping plug into the fuze well of the mine.
    - e. Remove the closing plug from the bottom of the mine.
    - f. Remove the booster from the mine.
    - g. Install the closing plug into the booster well.

**Evaluation Preparation:** Setup: Provide the soldier with the items listed in the conditions. Use inert equipment when performing this task. Brief soldier: Observe the soldier's performance for any improper procedures that may cause the mine to detonate.

<b>Performance Measures</b>	<b>Results</b>	
1. Disarmed the mine.	P	F
2. Checked for AHDs	P	F
3. Removed the mine.	P	F

**Evaluation Guidance:** Score the soldier GO if all steps are passed (P). Score the soldier NO-GO if any step is failed (F). If the soldier fails any step, show him how to do it correctly.

**References**  
**Required**

**Related**  
FM 20-32

**References  
Required**

**Related**  
FM 5-34  
GTA 5-10-36  
GTA 5-10-37  
TM 43-0001-36

**LOCATE MINES WITH THE AN/PSS-12 MINE DETECTOR**  
**051-192-1128**

**Conditions:** As a combat engineer squad member in a field environment, given an operational and tuned AN/PSS-12 mine detector and an area with hidden metallic mines.

**Standards:** Located mines using the AN/PSS-12 mine detector without overlooking mines or causing mine detonation.

**Performance Steps**

1. Search for mines in the standing position.

NOTE: This unit may require frequent adjustment of the sensitivity knob during operation.

- a. Adjust the handle of the mine detector to a comfortable position by loosening the knurl nut (Figure 051-192-1128-1).

**Performance Steps**

Figure 051-192-1128-1  
Mine detector

- b. Adjust the position of the search head so that it is parallel to the ground.
- c. Move the search head not more than 5 centimeters above the ground in a 2-meter path (Figure 051-192-1128-2).
- d. Sweep at a rate of approximately one meter per second.

**Performance Steps**

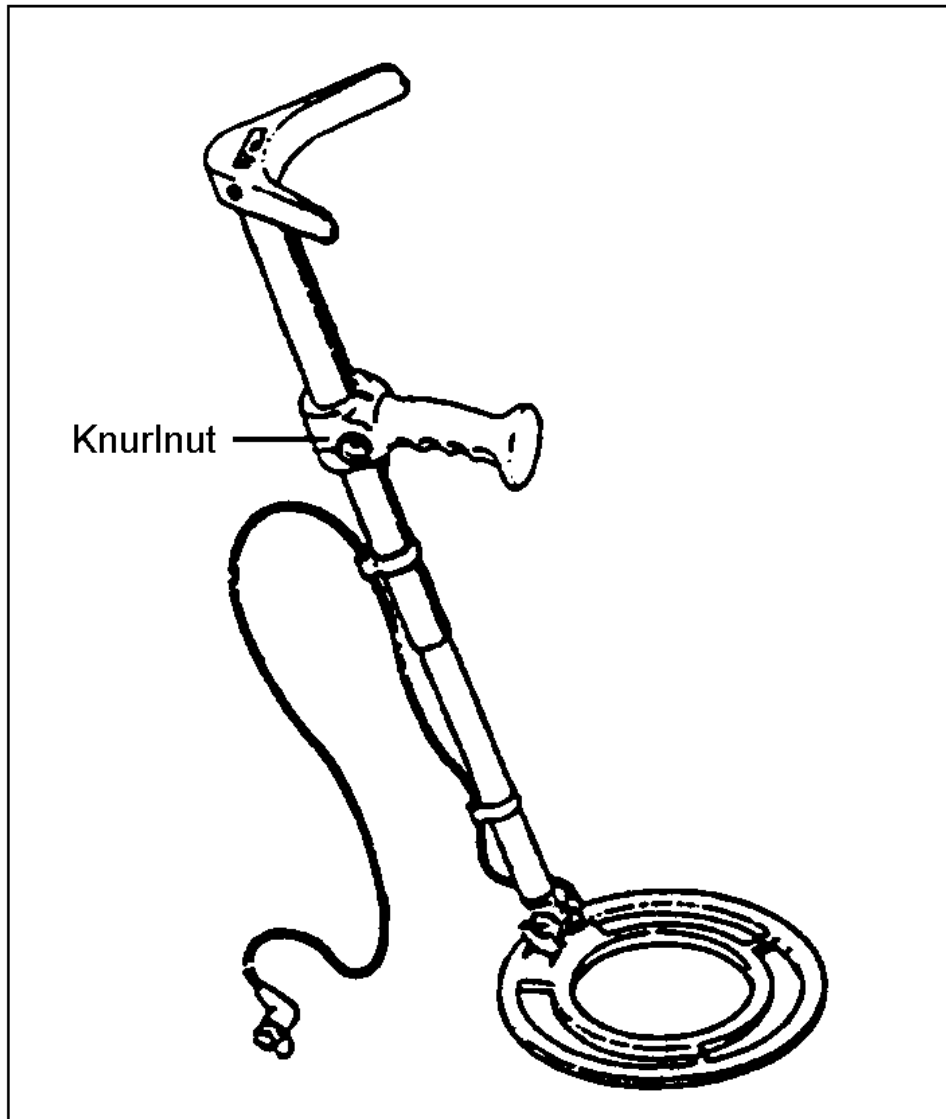
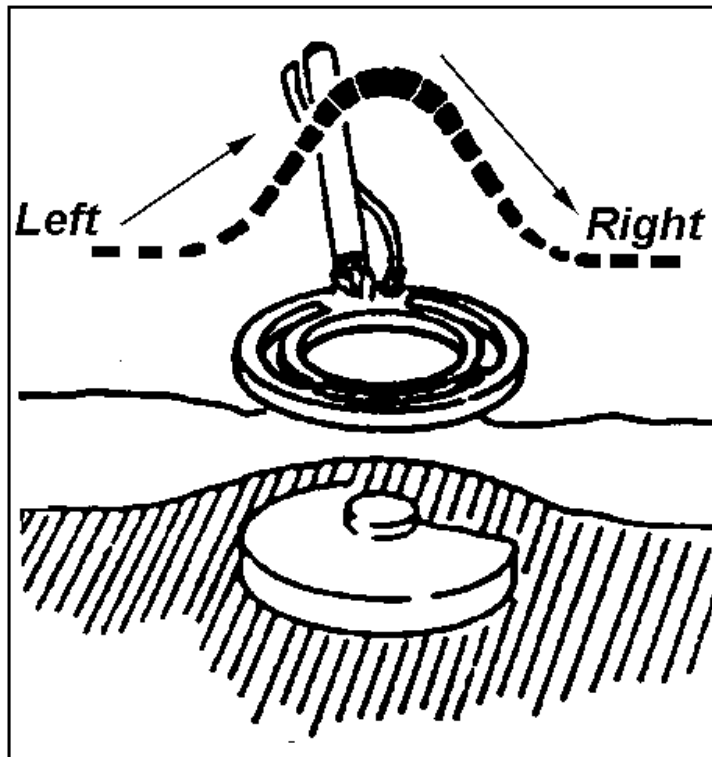

Figure 051-192-1128-2  
Directional mine detector (increase in tone)

NOTE: The inner ring of the search head indicates metal objects by sounding a tone in the earphone. This tone depends on the size (metal content), shape, and position of the object and its depth under the ground surface.

- e. Move the search head when you hear a tone above the object to locate its exact position (Figure 051-192-1128-3).

**Performance Steps**

Figure 051-192-1128-3  
Identifying the exact position of the mine

NOTE: Normally the tone will be highest when the search head is immediately above the object. For really tiny horizontal metal pins, the tone will be the highest nearer the inner ring of the search head than at the middle.

- f. Prevent interference during setting and searching by ensuring that the distance between the different search heads is not less than 2 meters.
2. Search for mines in the prone position.
    - a. Use only the inner part of the telescopic pole when operating the mine detector in the prone position (Figure 051-192-1128-4).

**Performance Steps**

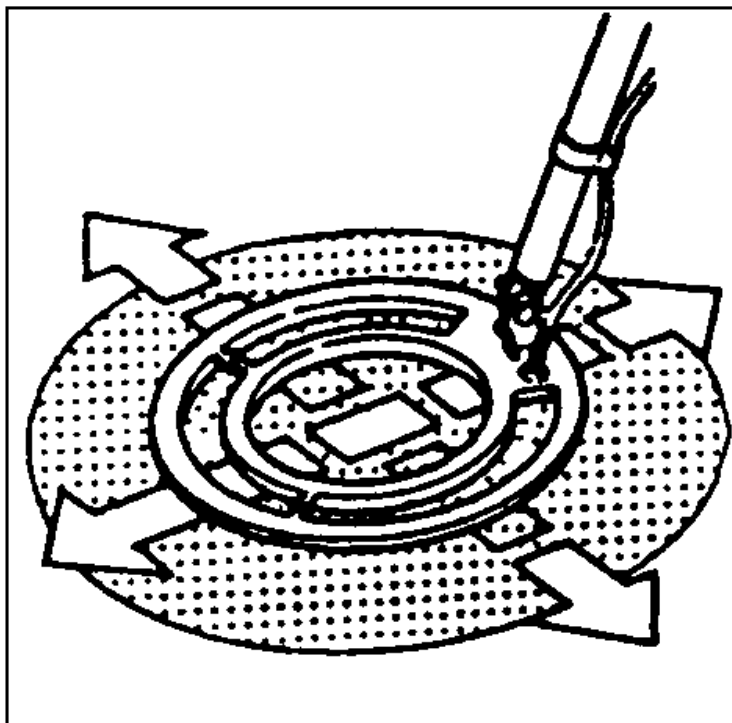
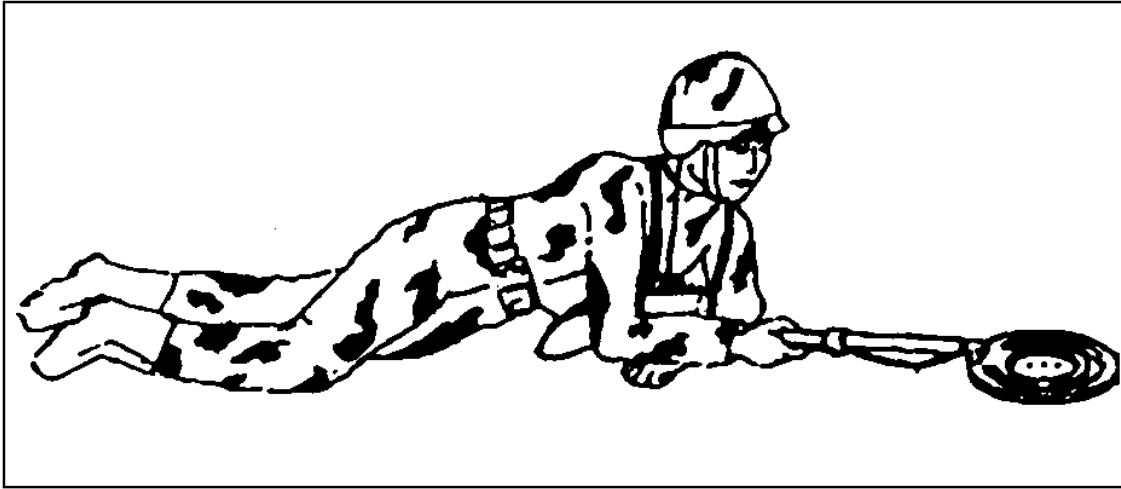

Figure 051-192-1128-4  
Searching in the prone position

b. Adjust the position of the search head so that it is parallel to the ground.

**NOTE:** If the indicator lamp flashes, change the batteries as soon as possible and readjust the settings. If searching is continued, a constant tone in the headphone will be obtained after some time and will render further searching impossible. If the ticking checking tone disappears or its frequency decreases, stop searching and readjust the setting.

**Evaluation Preparation:** Setup: Provide the soldier with the items listed in the conditions. Use an inert minefield when performing this task. Brief soldier: Tell the soldier to locate all buried metallic objects in a designated path. Observe the soldier's performance for any improper procedures that may cause the mines to detonate or cause the soldier to miss a mine in the search path.

<b>Performance Measures</b>	<b>Results</b>	
1. Searched for mines in the standing position.	P	F
2. Searched for mines in the prone position.	P	F

**Evaluation Guidance:** Score the soldier GO if all steps are passed (P). Score the soldier NO-GO if any step is failed (F). If the soldier fails any step, show him how to do it correctly.

**References**  
**Required**

**Related**  
TM 5-6665-298-10



## INSTALL AN M5 PRESSURE-RELEASE FIRING DEVICE ON ANTITANK (AT) MINES

051-192-1154

**Conditions:** As a combat engineer squad member in a field environment, given an M15 or an M19 AT mine with the appropriate fuze or detonator and arming wrench; an M5 pressure-release firing device; an M1 or an M2 mine activator; a standard base; 10- and 18-gauge wire; an entrenching tool; and a flat, solid object (wood or rock).

**Standards:** Installed the M5 pressure-release firing device on the M15 or M19 AT mine, in the proper sequence, without causing the mine to detonate.

### Performance Steps

1. Install the M15 or M19 AT mine.
  - a. Inspect the mine and the appropriate fuze or detonator.
  - b. Install the fuze or the detonator in the mine.
  - c. Dig a hole to fit the mine with a trench coming off the side at an approximate 45-degree angle towards the friendly side (Figure 051-192-1154-1).

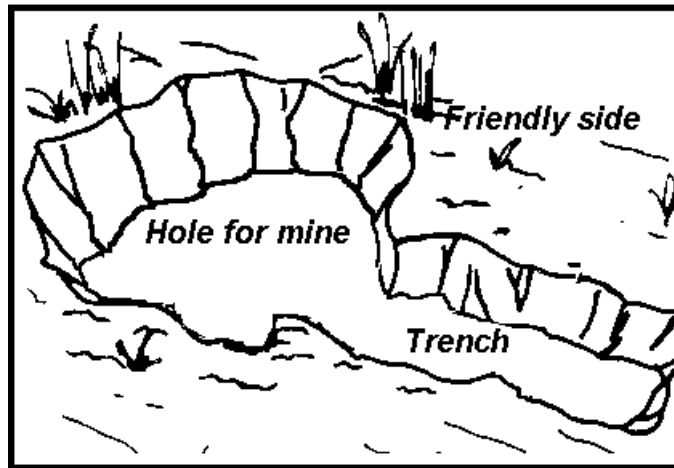

Figure 051-192-1154-1  
Hole for the mine with an open trench

2. Install the M5 pressure-release firing device.
 

**WARNING: HANDLE THE ANTIHANDLING DEVICE (AHD) WITH CARE DURING ASSEMBLY. FAILURE TO DO SO COULD RESULT IN DETONATION.**

  - a. Inspect the firing device for damage.
  - b. Keep pressure on the lid while inserting a length of 10-gauge wire in the positive safety hole. Remove the locking safety pin and replace it with a length of 18-gauge wire (Figure 051-192-1154-2).

Performance Steps

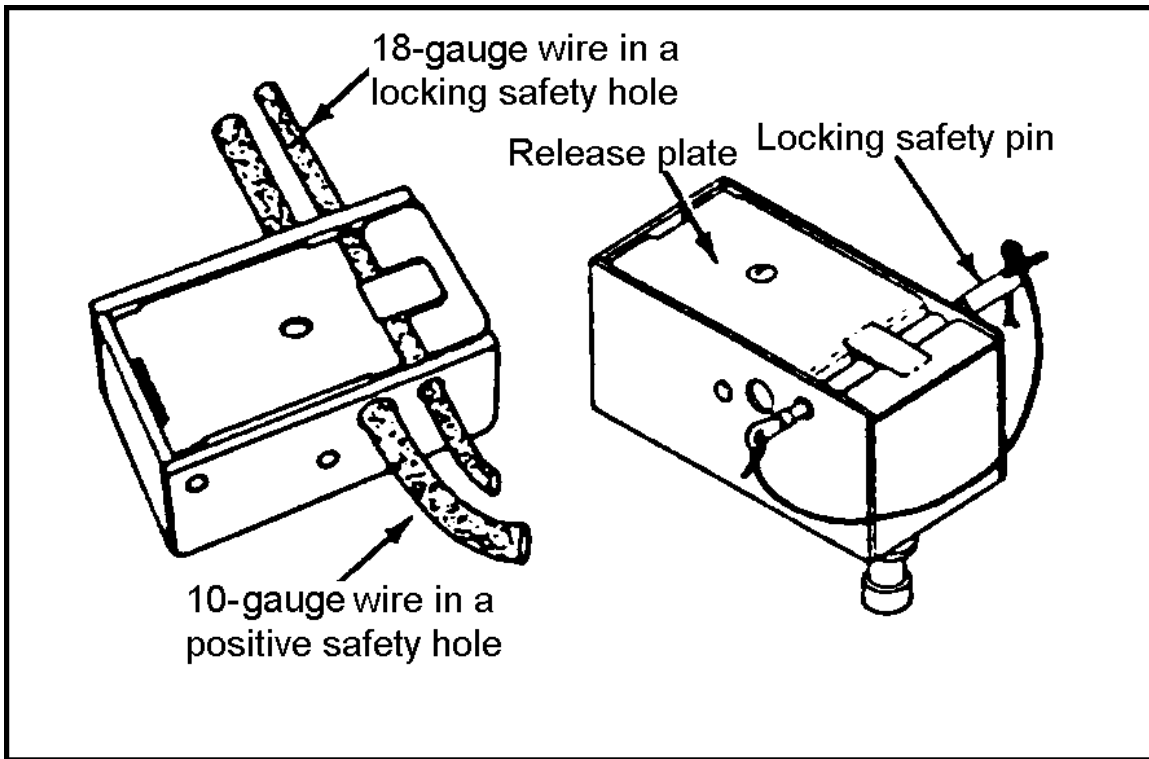

Figure 051-192-1154-2  
Pressure-release firing device

NOTE: Other items, such as a wire clothes hanger, may be used instead of the 10- or 18-gauge wire.  
c. Screw the activator to the standard base. Figures 051-192-1154-3 shows an M1 and an M2 mine activator.

## Performance Steps

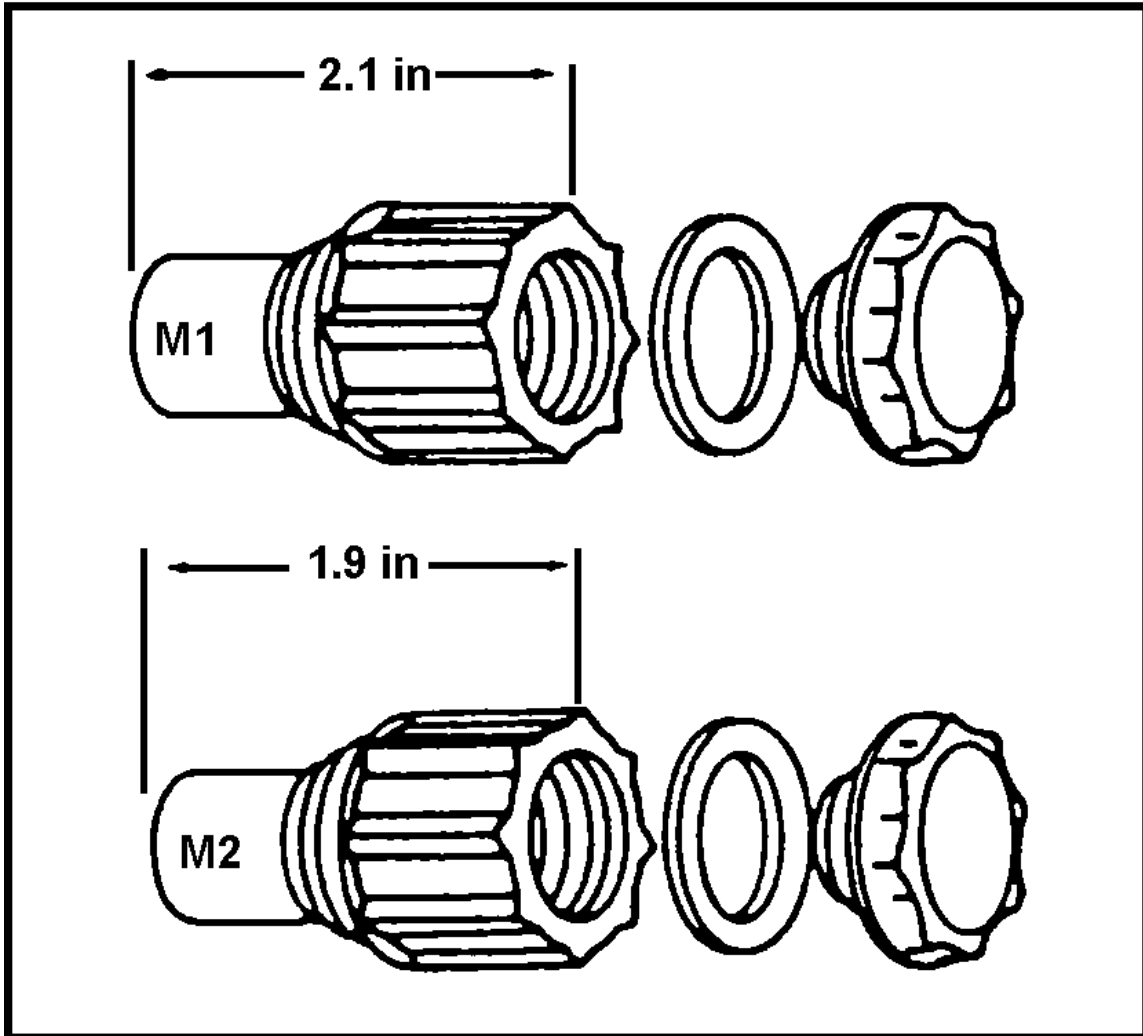

Figure 051-192-1154-3  
M1/M2 AT mine activator

NOTE: The M1 activator is used with the M15 AT mine and the M2 activator is used with the M19 AT mine.

- d. Screw the standard base to the M5 (Figure 051-192-1154-4).

Performance Steps

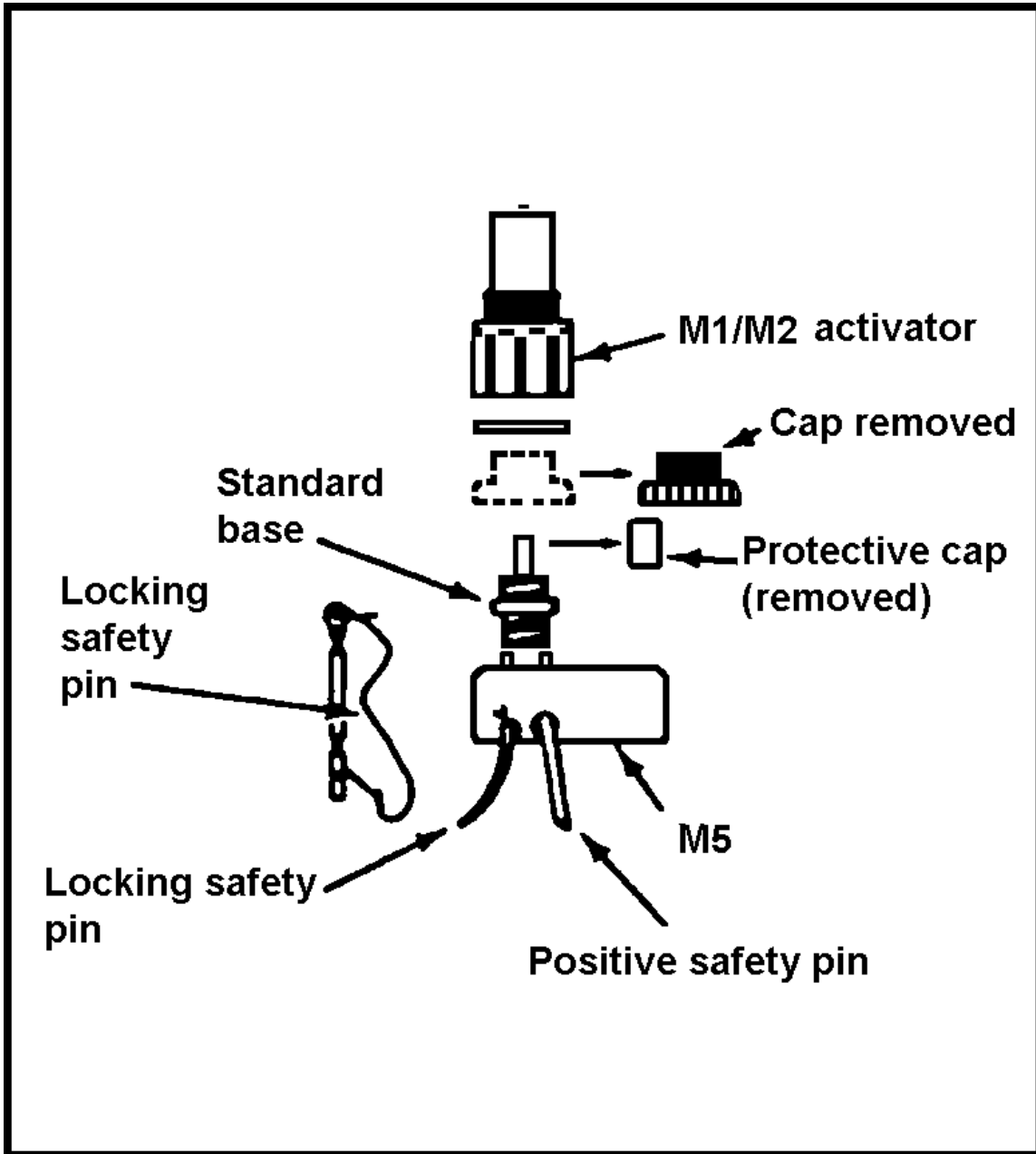

Figure 051-192-1154-4  
M5 firing device

NOTE: Ensure that the pins are oriented toward the outside edge of the mine for easy removal and that the safety pins do not fall out.

- e. Place the mine in the hole upside down. Screw the M5 firing device into the secondary fuze well on the bottom of the mine.
- f. Turn the mine over in the hole. Ensure that the safety pins remain in place. Place the firing device on a solid, level surface with the pins toward the trench (Figure 051-192-1154-5).

Performance Steps

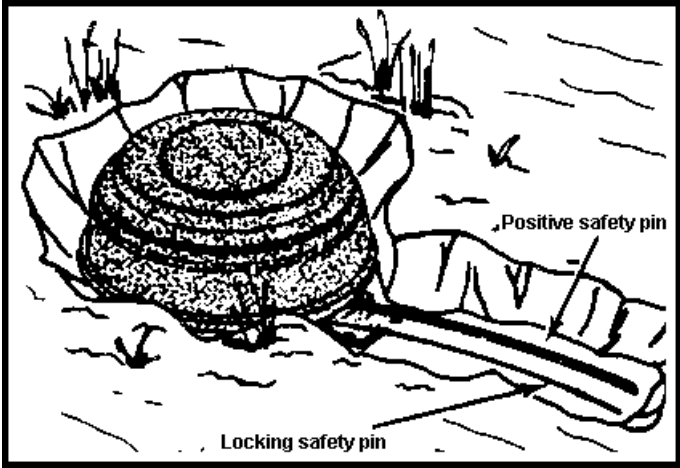

Figure 051-192-1154-5  
Arming the mine

WARNING: ENSURE THAT THE MINE AND FIRING DEVICE ARE RESTING ON A FIRM FOUNDATION BEFORE REMOVING THE PINS.

- 3. Arm the mine.
  - a. Arm the mine.
  - b. Cover and camouflage the mine up to the pressure plate. Leave the trench at the side of the mine exposed. This will leave enough room to remove the safety pins.
- 4. Arm the firing device.
  - a. Remove the locking safety pin.

WARNING: IF YOU FEEL A JAR OR HEAR A METALLIC CLICK, STOP AND NOTIFY THE NONCOMMISSIONED OFFICER IN CHARGE (NCOIC). THE FIRING PIN HAS GONE FORWARD AND IS RESTING ON THE POSITIVE SAFETY PIN. DO NOT REMOVE THE POSITIVE SAFETY PIN.

- b. Remove the positive safety pin.
- WARNING: IF THE POSITIVE SAFETY PIN IS DIFFICULT TO REMOVE, STOP AND NOTIFY THE NCOIC.
- c. Finish camouflaging the mine. Give the safety pins to the NCOIC.

**Evaluation Preparation:** Setup: Provide the soldier with the items in the condition statement. The soldier will install the M15 AT mine or the M19 AT mine. Use inert equipment when performing this task. Brief soldier: Ensure that the soldier has the proper fuze or detonator, an arming wrench, and the appropriate activator for the mine being installed.

Performance Measures	Results	
1. Installed the M15 or M19 AT mine.	P	F
2. Installed the M5 pressure-release firing device.	P	F
3. Armed the mine.	P	F
4. Armed the firing device.	P	F

**Evaluation Guidance:** Score the soldier GO if all steps are passed (P). Score the soldier NO-GO if any step is failed (F). If the soldier fails any step, show him how to do it correctly.

**References**

**Required**

**Related**

FM 20-32

FM 5-34

GTA 5-10-36

GTA 5-10-37

TM 43-0001-36

TM 9-1375-213-12

**REMOVE AN M5 PRESSURE-RELEASE FIRING DEVICE FROM ANTITANK (AT) MINES**  
**051-192-1155**

**Conditions:** As a combat engineer squad member in a field environment, given the location of an emplaced M15 or M19 AT mine with an M5 firing device attached; 10- and 18-gauge wire; and the appropriate arming wrench for the mine being disarmed.

**Standards:** Removed the M5 firing device from the mine, in the proper sequence, without causing the mine to detonate.

**Performance Steps**

WARNING: DISARMING AN ARMED FIRING DEVICE IS CONSIDERED HAZARDOUS. ALL UNNECESSARY PERSONNEL MUST LEAVE THE AREA DURING DISARMING PROCEDURES. BEFORE ATTEMPTING TO DISARM AND REMOVE THE MINE, CHECK FOR PRESSURE PRONGS, TILT RODS, TRIP WIRES, AND ANY OTHER TYPE OF BOOBY TRAP. IF ANY OF THESE CONDITIONS EXIST, NOTIFY THE NONCOMMISSIONED OFFICER IN CHARGE (NCOIC). DO NOT ATTEMPT TO DISARM THE MINE.

1. Locate the firing device.

WARNING: DO NOT APPLY PRESSURE TO THE MINE'S PRESSURE PLATE AT ANY TIME.

WARNING: DO NOT RELEASE THE PRESSURE THAT IS BEING APPLIED TO THE DEVICE.

- a. Clear the camouflage away from the mine.
  - b. Hold the mine firmly in place with one hand. Do not put pressure on the pressure plate.
  - c. Feel with the other hand for antihandling devices (AHDs) by digging around the sides and underneath the mine until the firing device is located.
2. Disarm the firing device.
    - a. Install the positive safety pin first (10-gauge wire).
    - b. Install the locking safety pin (18-gauge wire).
  3. Use the appropriate arming wrench to disarm the mine.
  4. Remove the mine and firing device from the hole. Ensure that the safety pins remain in place.
  5. Remove the firing device from the mine.
    - a. Turn the mine upside down and remove the the firing device from the mine. Ensure that the safety pins remain in place on the firing device.
    - b. Disassemble the activator and standard base from the firing device.
  6. Remove the fuze or detonator from the mine.
  7. Give all the components to the NCOIC.

**Evaluation Preparation:** Set up: Provide the soldier with the items in the condition statement. The soldier will remove the M15 AT mine or the M19 AT mine. Use inert equipment when performing this task. Brief soldier: Ensure that the soldier has the proper arming wrench for the mine being disarmed.

<b>Performance Measures</b>	<b>Results</b>
1. Located the firing device.	P    F
2. Disarmed the firing device.	P    F
3. Used the appropriate arming wrench to disarm the mine.	P    F
4. Removed the mine and firing device from the hole. Ensured that the safety pins remained in place.	P    F

**Performance Measures**

**Results**

- |   |   |   |
|---|---|---|
| 5. Removed the firing device from the mine.     | P | F |
| 6. Removed the fuze or detonator from the mine. | P | F |
| 7. Gave all the components to the NCOIC.        | P | F |

**Evaluation Guidance:** Score the soldier GO if all steps are passed (P). Score the soldier NO-GO if any step is failed (F). If the soldier fails any step, show him how to do it correctly.

**References**

**Required**

**Related**

FM 20-32  
FM 5-34  
GTA 5-10-36  
GTA 5-10-37  
TM 43-0001-36  
TM 9-1375-213-12



## Subject Area 2: Basic Demolitions

**NEUTRALIZE BOOBY TRAPS****051-193-1013**

**Conditions:** As a combat engineer squad member in a field environment, given a suspected booby-trapped area, explosives, demolition equipment, a grapnel hook attached to 50 meters of rope, and a standard booby trap marking sign.

**Standards:** Located the booby trap and marked the booby trap with the material provided if it could not be neutralized. Used the materials provided to neutralize the booby trap without causing injury to personnel.

**Performance Steps**

1. Detect booby traps without activating them.
  - a. Detect booby traps in outside areas.
    - (1) Look for explosive and nonexplosive traps at and above ground level.
    - (2) Look for hidden traps near litter, unused construction material, and any movable, valuable, or useful items.
    - (3) Look for disturbed ground, unusual marks on the ground, and weathered camouflaged materials.
    - (4) Search for traps around machinery and abandoned vehicles.
    - (5) Probe to locate firing devices.
    - (6) Look and feel carefully for trip wires.
  - b. Detect booby traps inside buildings.
    - (1) View the inside of the building or room from outside before entering, whenever possible.
    - (2) Work from the lowest level up, if possible.
    - (3) Investigate electrical circuits before turning switches, connecting broken wires, or using electrical appliances.
    - (4) Look carefully where you are walking. Inspect loose tiles, floorboards, or carpets. These may conceal traps with pressure fuses.
    - (5) Look carefully for release fuses or wires attached to pull fuses. Do this before moving pictures, furniture, boxes, drawers, and other items you find indoors.
    - (6) Check the inside of fireplaces, stoves, furnaces, flues, and dead-air spaces for booby traps.
2. Identify detonation devices without activating them.
  - a. Detonate explosives. Use the following information to identify the six types of detonation actions:
    - (1) Pressure. The downward force of a man's foot or the wheel or track of a vehicle activates a fuse (Figure 051-193-1013-1).

**Performance Steps**

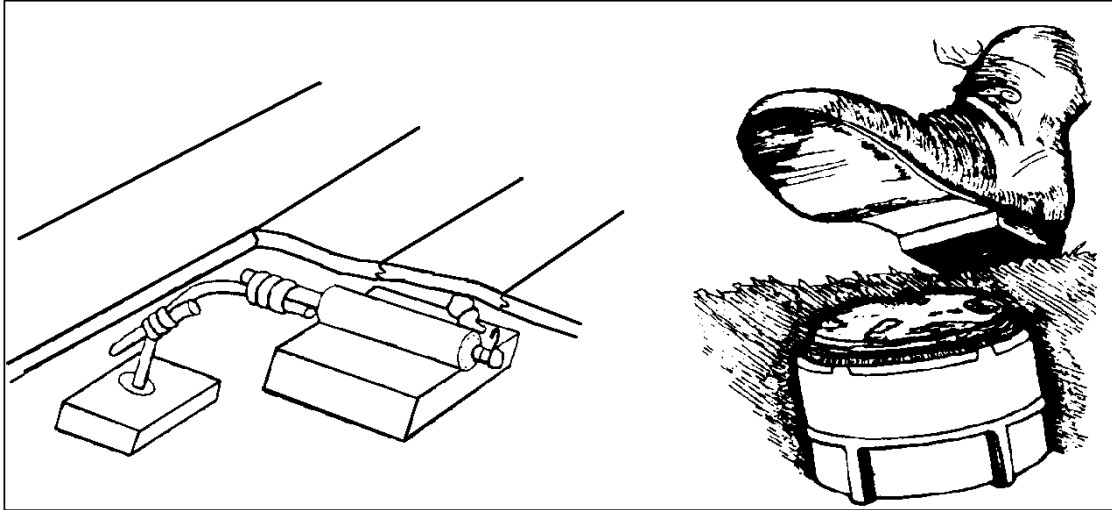

Figure 051-193-1013-1  
Weight activation

- (a) The pressure method is activated by a downward force of a soldier's weight, a vehicle wheel, or from a similar source.
  - (b) The activation device can be pressure prongs, a pressure plate, or any other kind of pressure-activated switch.
  - (b) The amount of pressure usually cannot be determined.
  - (c) The activation device can be pressure prongs, a pressure plate, or any other kind of pressure-activated switch.
- (2) Pull. The pull on the trip wire attached to the fuse activates the fuse (Figure 051-193-1013-2.)

## Performance Steps



Figure 051-193-1013-2  
Trip wire activation

- (a) Trip wires should be looked for and felt for.
  - (b) Trip wires may be tied between fixed objects and the initiating source.
  - (c) Trip wires may be located anywhere between ankle and neck high on the average height soldier.
  - (d) Trip wires are usually camouflaged in the same color as their surroundings.
  - (e) Trip wires may be strung at different angles to avoid detection and provides optimum employment against the enemy.
  - (f) Trip wires on a pull employment method of booby trap can usually be identified by the trip wire being slightly slack or loose.
- (3) Tension release. Releasing the tension activates the fuse. Cutting a trip wire is an example of tension release (Figure 051-193-1013-3).

**Performance Steps**

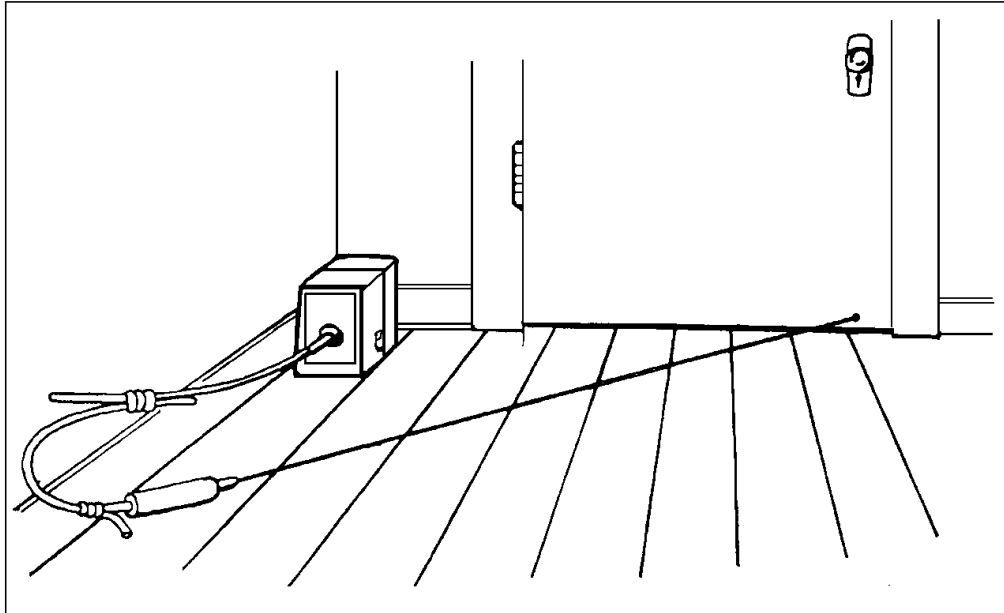

Figure 051-193-1013-3  
Tension release activation

- (a) Trip wires should be looked for and felt for.
  - (b) Trip wires may be tied between fixed objects and the initiating source.
  - (c) Trip wires may be located anywhere between ankle and neck high on the average height soldier.
  - (d) Trip wires are usually camouflaged in the same color as their surroundings.
  - (e) Trip wires may be strung at different angles to avoid detection, as well as to provide optimum employment against the enemy.
  - (f) Trip wires on a tension-release employment method of booby trap can usually be identified by the trip wire being under considerable tension.
- (4) Pressure release. Removing weight will activate the fuse (Figure 051-193-1013-4).

**Performance Steps**

Figure 051-193-1013-4  
Pressure release activation

- (a) The pressure release is activated by removing a weighted object from the activating mechanism.
  - (b) The objects can be anything. It is usually something of interest or value to the unsuspecting soldier such as war trophies (weapons, binoculars, knives, and so forth), possible intelligence items (maps, documents, and so forth), or anything to draw attention to the object.
- (5) Electrical. Closing an electric circuit activates the fuse (Figure 051-193-1013-5).

**Performance Steps**

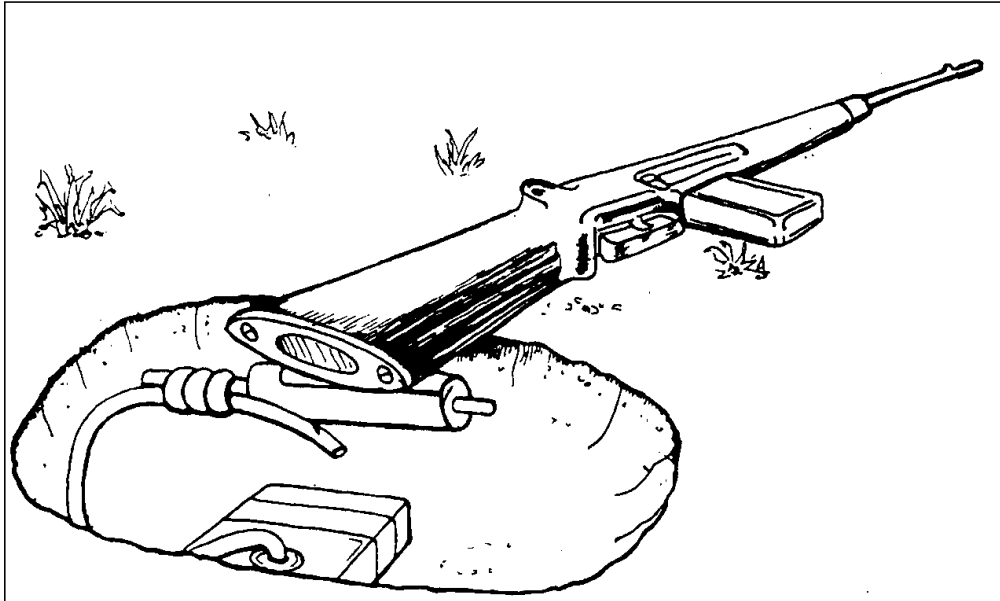
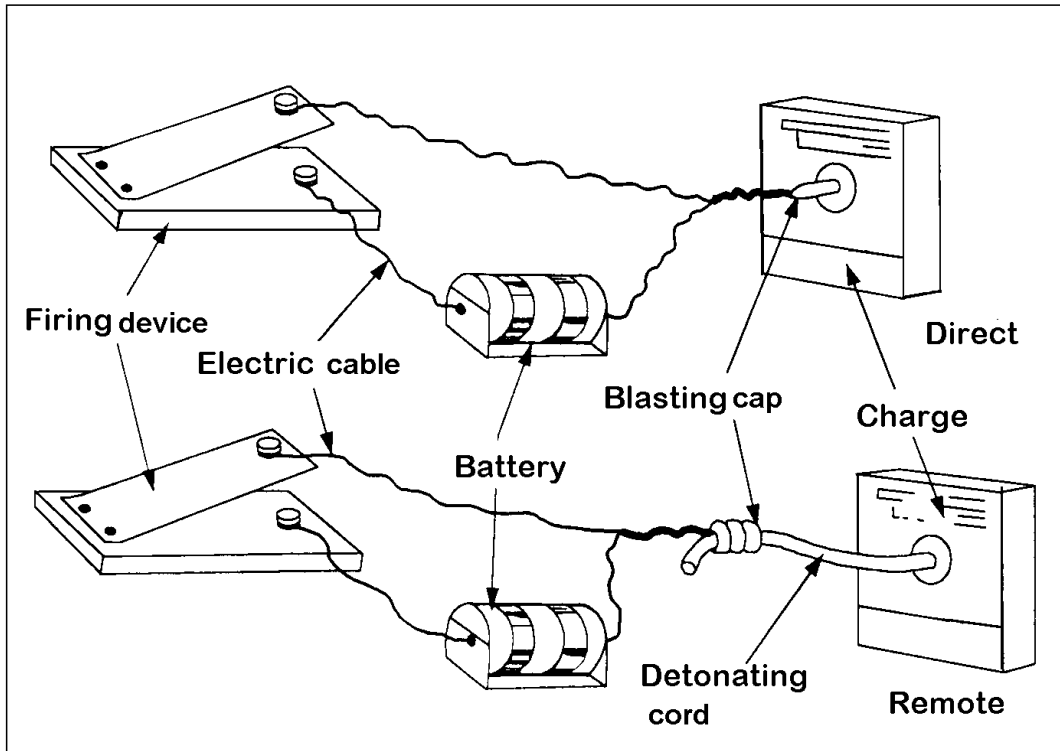

Figure 051-193-1013-5  
Electrical activation

- (a) The electrical circuit consists of a power source, a firing mechanism (usually some form of electrical detonator), a firing wire, and an activation switch.
- (b) The power source can be in the form of a battery, electrical current from a power outlet, or generated from static electricity.
- (c) The firing wire can be any wire available to the user.
- (d) The activation switch can be in the form of something as simple as tin can lids separated by paper; a clothespin with wires wrapped around the end; to a light switch in a room.
- (e) The electrical circuit is usually camouflaged by its surroundings and is very difficult to detect without careful inspection.
- (6) Timer rundown. A timer reaching the preset time activates the fuse (Figure 051-193-1013-6).

## Performance Steps

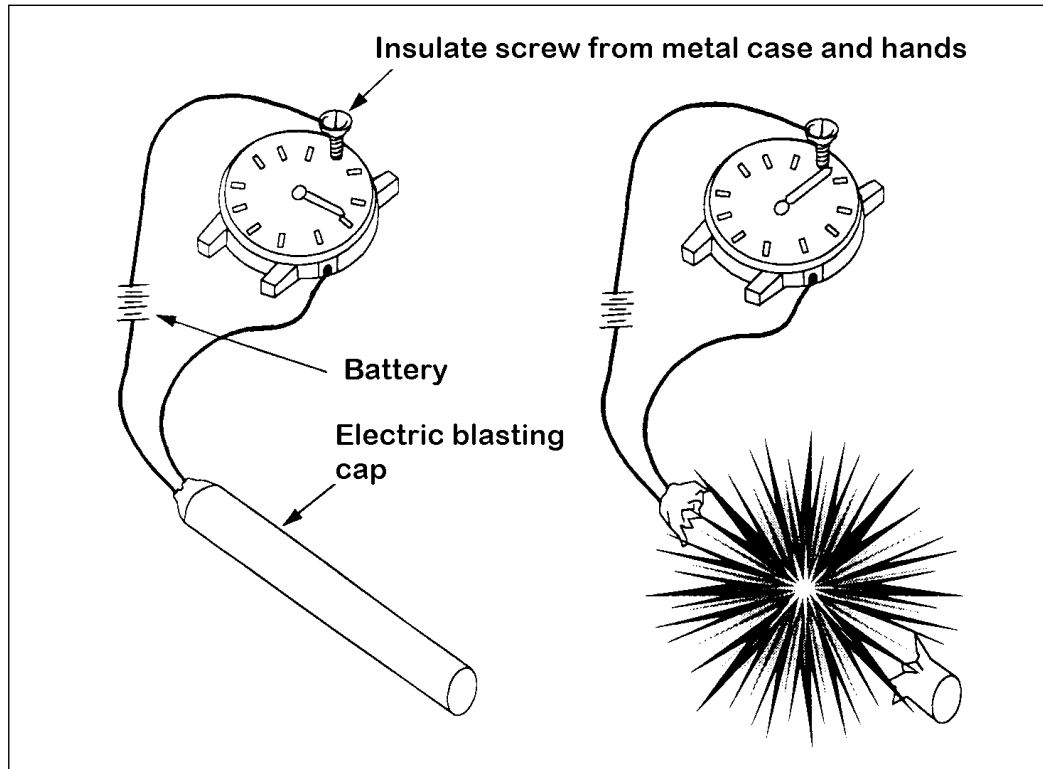

Figure 051-193-1013-6  
Time activation

- b. Initiate the following two types of mechanical traps:
- (1) Passive mechanical traps have few, if any, moving parts and require the soldier to act directly against them. A camouflaged pit containing upturned spikes or scattered caltrops is an example.
  - (2) Active mechanical traps have moving components and require the soldier to activate the trap. This is done by tripping a latch, pulling a wire, or releasing a counterweight. Examples of active mechanical traps are bamboo whips, snares, bear traps, or swing maces (Figure 051-193-1013-7).

**Performance Steps**

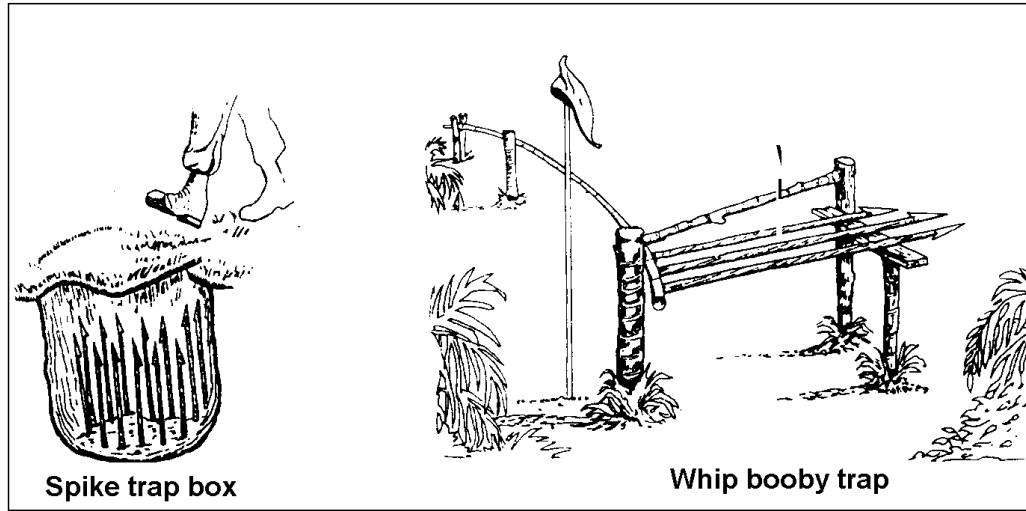

Figure 051-193-1013-7  
Mechanical activation

**CAUTION: ENSURE THAT FRIENDLY PERSONNEL ARE AT A SAFE DISTANCE BEFORE NEUTRALIZING BOOBY TRAPS.**

3. Neutralize the booby traps.

NOTE: Report the location, type of traps, and any unique method used to the noncommissioned officer in charge (NCOIC).

- a. Mark all booby traps that cannot be destroyed at the time of detection. Mark traps with the standard sign or use an expedient marker as designated by the unit (Figure 051-193-1013-8).



## Performance Steps

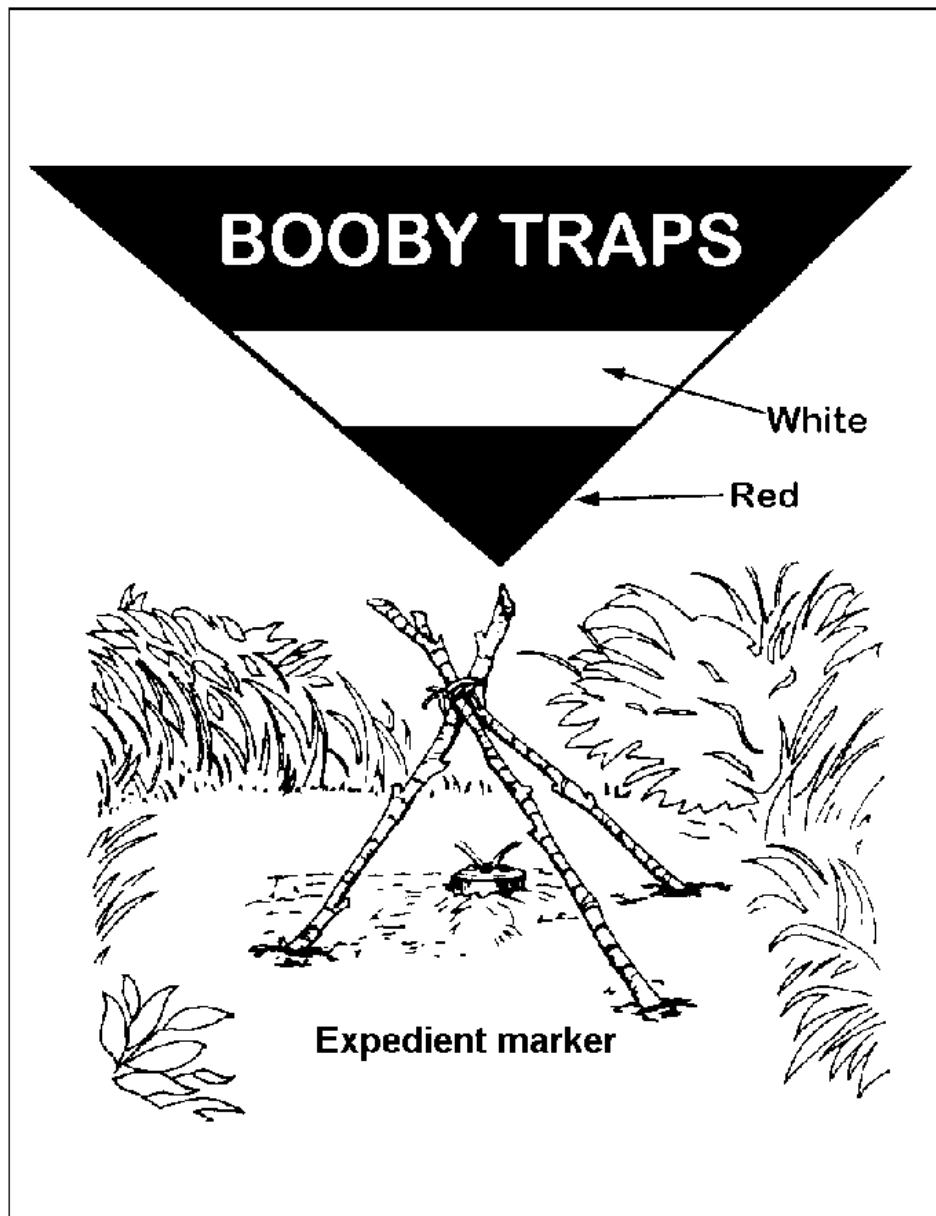

Figure 051-193-1013-8  
Standard booby-trap sign

NOTE: The standard booby-trap sign is a red triangle with a 3-inch, white strip in the center of it. The word "booby traps" will be spelled out in white letters across the top of the sign. The sign will be placed so that the right-angled apex is pointing down.

- b. Neutralize traps by activating or blocking the firing chain and/or the mechanical sequence.

**Performance Steps**

- (1) Activate the firing chains and/or mechanical sequences using a rope or wire that is at least 50 meters long. Hook or tie one end of the rope to the trip wires, pins, or restraining weights. Move to a protected position (at least 50 meters away) and pull the other end of the rope (Figure 051-193-1013-9). Wait at least 5 minutes before approaching a trap that did not detonate or operate.

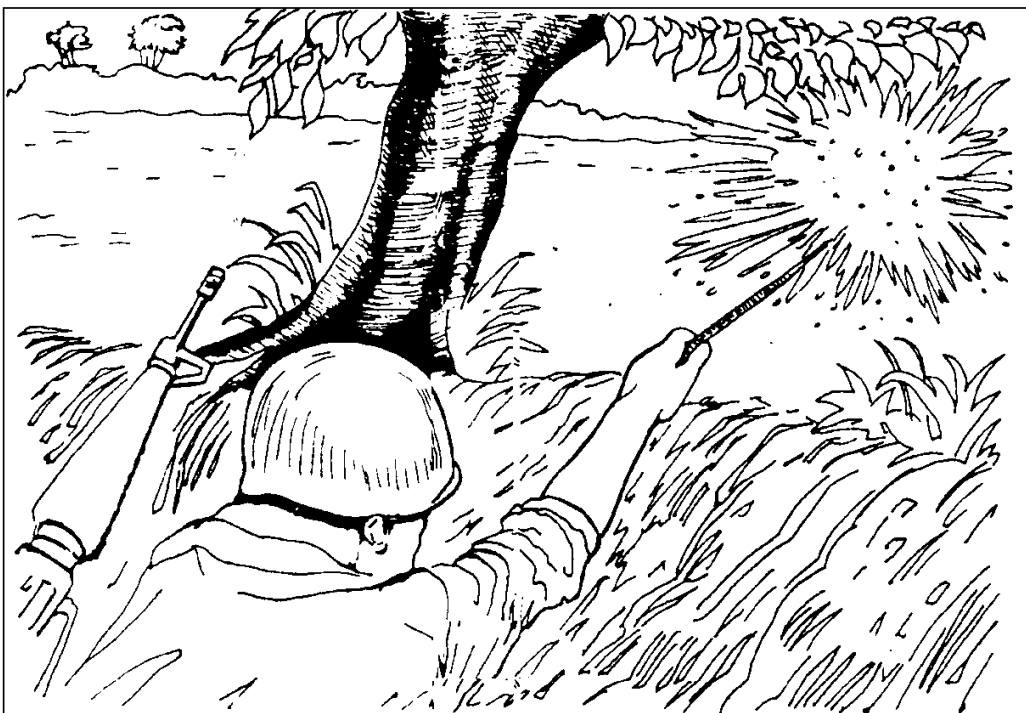

Figure 051-193-1013-9  
Neutralizing a booby trap

- (2) Block firing chains and/or the mechanical sequence by cutting slack trip wires and electrical conductors or by replacing safety pins.

NOTE: You can neutralize passive mechanical traps by scraping the ground, filling the pit, or removing or breaking spikes and blades.

- c. Destroy traps in place by detonating a 1-pound explosive charge next to the main charge. Place a 1-pound explosive charge within 6 inches, but not touching, the main charge of the booby trap.
- d. Neutralize passive mechanical booby traps by filling in the pit or by breaking spikes, blades, and so forth.

**Evaluation Preparation:** Setup: Provide the soldier with the items listed in the conditions statement. Brief soldier: Tell the soldier to identify the booby trap and mark the the booby trap if it cannot be neutralized.

**Performance Measures**

1. Detected booby traps without activating them.
2. Identified detonation devices.

**Results**

P	F
P	F

**Performance Measures**

3. Neutralized the booby traps.
4. Marked the traps not destroyed for other friendly soldiers.

**Results**

P	F
P	F

**Evaluation Guidance:** Score the soldier GO if all steps are passed. Score the soldier NO-GO if any step is failed. If the soldier fails any step, show him how to do it correctly.

**References****Required****Related**

FM 20-32

## INSTALL AN M142 MULTIPURPOSE FIRING DEVICE

051-193-1101

**Conditions:** As a combat engineer squad member in a field environment, given a complete M142 multipurpose firing device (MPFD), an M15 or M19 antitank (AT) mine with an M1 or an M2 activator, a standard base, an entrenching tool, a flat solid object (wood or rock), and a suitable working area.

**Standards:** Installed the M142 MPFD in the pressure-release mode on the mine without activating the MPFD prematurely.

### Performance Steps

1. Install the M15 or M19 AT mine.
  - a. Inspect the mine and appropriate fuze or detonator.
  - b. Install the fuze or the detonator in the mine.
  - c. Dig a hole to fit the mine with a trench coming off the side at about a 45-degree angle towards the friendly side (Figure 051-193-1101-1).

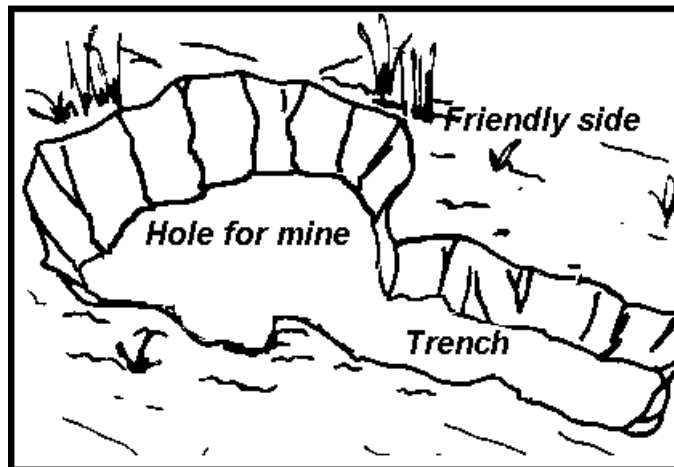

Figure 051-193-1101-1  
Hole for the mine with an open trench

2. Install the M142 MPFD in the pressure-release mode.

**WARNING: HANDLE THE MPFD WITH CARE DURING ASSEMBLY. FAILURE TO DO SO COULD RESULT IN DETONATION.**

  - a. Inspect the firing device for damage and check all safety pins for placement and ease of removal (Figure 051-193-1101-2).

Performance Steps

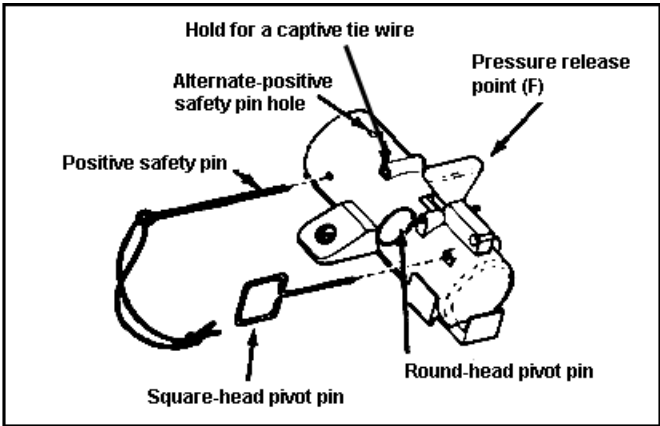

Figure 051-193-1101-2  
M142 in pressure-release mode

- b. Screw the standard base into the firing device (Figure 051-193-1101-3).

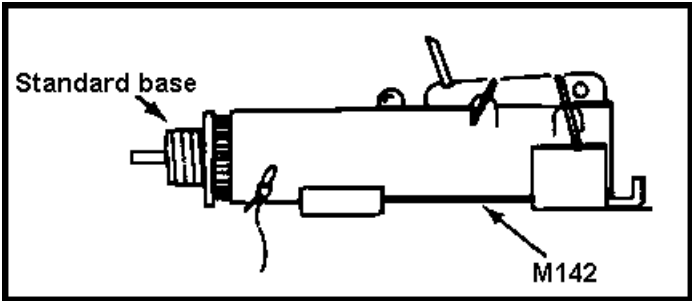

Figure 051-193-1101-3  
Standard base to a M142

- c. Screw the firing device and standard base into the M1 or M2 activator (Figure 051-193-1101-4).

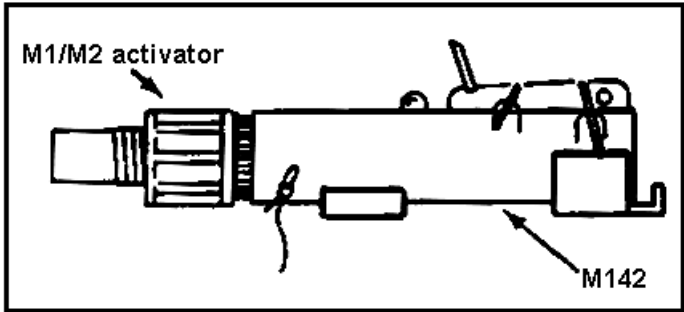

Figure 051-193-1101-4  
M142 and standard base with M1/M2 activator

NOTE: Use the M1 activator with the M15 AT mine and use the M2 activator with the M19 AT mine.  
d. Screw the firing device, standard base, and activator into the side well of the mine (Figure 051-193-1101-5).

**Performance Steps**

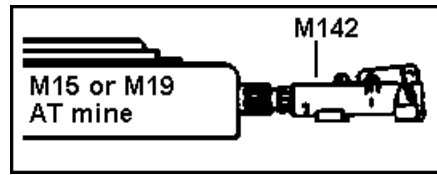

Figure 051-193-1101-5  
M142 showing pivot pin

- e. Place the mine and firing device in the hole. Ensure that the safety pins remain in place.
- 3. Place an object on the firing device at the pressure release point (F) (Figure 051-193-1101-6).

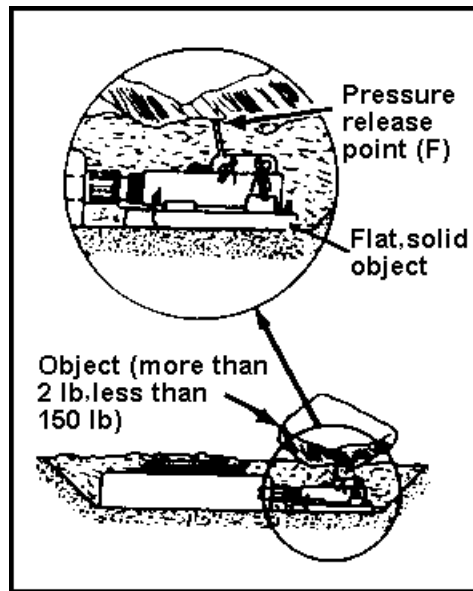

Figure 051-193-1101-6  
M142 in pressure-release mode in the side fuze well

NOTE: Use an object weighing at least 2 pounds but no more than 150 pounds.

- 4. Arm the mine.
  - a. Arm the mine.
  - b. Cover and camouflage the mine up to the pressure plate. Leave the trench at the side of the mine exposed. This will give room to remove the safety pins.
- 5. Arm the firing device.
  - a. Use a wire to carefully remove the round-head pin (pivot pin), when necessary.  
**WARNING: IF YOU FEEL A JAR OR HEAR A METALLIC CLICK, STOP AND NOTIFY THE NONCOMMISSIONED OFFICER IN CHARGE (NCOIC). THIS IS A RESULT OF THE FIRING PIN GOING FORWARD AND RESTING ON THE POSITIVE SAFETY PIN. DO NOT REMOVE THE POSITIVE SAFETY PIN.**
  - b. Remove the positive safety pin.  
**WARNING: IF THE POSITIVE SAFETY PIN IS DIFFICULT TO REMOVE, STOP AND NOTIFY THE NCOIC.**
  - c. Complete camouflaging the mine. Give the safety pins to the NCOIC.

**Evaluation Preparation:** Set up: Provide the soldier with the items in the condition statement. The soldier will install the M15 AT mine or the M19 AT mine. Brief soldier: Ensure that the soldier has the proper fuze or detonator, an arming wrench, and the appropriate activator for the mine being installed. Use inert equipment when performing this task.

<b>Performance Measures</b>	<b>Results</b>	
1. Installed the mine.	P	F
2. Installed the M142 MPFD in the press-release mode.	P	F
3. Placed an object on the point (F).	P	F
4. Armed the mine	P	F
5. Armed the firing device.	P	F
6. Camouflaged the mine.	P	F

**Evaluation Guidance:** Score the soldier GO if all steps are passed (P). Score the soldier NO-GO if any step is failed (F). If the soldier fails any step, show him how to do it correctly.

**References  
Required**

- Related**  
 FM 20-32  
 FM 5-250  
 FM 5-34  
 TM 9-1375-213-12

## REMOVE AN M142 MULTIPURPOSE FIRING DEVICE

051-193-1102

**Conditions:** As a combat engineer squad member in a field environment, given the location of an emplaced M15 or M19 antitank mine (AT) with an M142 multipurpose firing device (MPFD) attached, safety pins, and a sandbag.

**Standards:** Removed the M142 MPFD from the mine, in the proper sequence, without detonating the mine.

### Performance Steps

WARNING: DISARMING AN ARMED FIRING DEVICE IS CONSIDERED HAZARDOUS. ALL UNNECESSARY PERSONNEL MUST LEAVE THE AREA DURING DISARMING PROCEDURES. BEFORE ATTEMPTING TO DISARM AND REMOVE THE MINE, CHECK FOR PRESSURE PRONGS, TILT RODS, TRIP WIRES, AND ANY OTHER TYPE OF BOOBY TRAP. IF ANY OF THESE CONDITIONS EXIST, NOTIFY THE NONCOMMISSIONED OFFICER IN CHARGE (NCOIC) AND DO NOT ATTEMPT TO DISARM THE MINE.

1. Locate the mine. Locate by visual means or by using the AN/PSS-12 mine detector.
2. Locate the firing device.  
WARNING: DO NOT APPLY PRESSURE TO THE MINE'S PRESSURE PLATE AT ANY TIME.
  - a. Clear the camouflage away from the mine.
  - b. Hold the mine firmly in place with one hand. Do not put pressure on the pressure plate.
  - c. Feel for antihandling devices (AHDs), with the other hand, by digging around the sides and underneath the mine, until the firing device is located.
3. Disarm the firing device.
  - a. Install the positive safety pin first.
  - b. Install the locking safety pin.
4. Disarm the mine by using the appropriate arming wrench.
5. Remove the mine and firing device from the hole. Ensure that the safety pins remain in place.
6. Remove the firing device from the mine.
  - a. Remove the firing device from the mine. Ensure that the safety pins remain in place on the firing device.
  - b. Disassemble the activator and standard base from the firing device.
7. Remove the fuze or detonator from the mine.
8. Give all the components to the NCOIC.

**Evaluation Preparation:** Set up: Provide the soldier with the items in the condition statement. The soldier will remove the M15 AT mine or the M19 AT mine. Brief soldier: Ensure that the soldier has the proper arming wrench for the mine being disarmed. Use inert equipment when performing this task.

### Performance Measures

- |                                | Results |   |
|--------------------------------|---------|---|
| 1. Located the mine.           | P       | F |
| 2. Located the firing device.  | P       | F |
| 3. Disarmed the firing device. | P       | F |
| 4. Disarmed the mine.          | P       | F |



**Performance Measures**

5. Removed the mine and firing device from the hole.
6. Removed the firing device from the mine.
7. Removed the fuze or detonator from the mine.
8. Gave all the components to the NCOIC.

**Results**

P	F
P	F
P	F
P	F

**Evaluation Guidance:** Score the soldier GO if all steps are passed (P). Score the soldier NO-GO if any step is failed (F). If the soldier fails any step, show him how to do it correctly.

**References****Required****Related**

FM 20-32  
 FM 5-250  
 FM 5-34  
 TM 9-1375-213-12

## CONSTRUCT DEMOLITION FIRING SYSTEMS

051-193-1310

**Conditions:** As a combat engineer squad member in a field environment, given military explosives, detonating cord, M11 or M16 branch lines, M12 or M13 transmission lines, M2 crimpers, a demolition knife, and sandbags.

**Standards:** Constructed a demolition firing system (stand alone or combination), in sequence, without causing premature detonation.

### Performance Steps

NOTE: There are two types of firing systems: a stand-alone firing system and a combination firing system. On a stand-alone firing system, the initiation set(s), transmission line(s), and branch line(s) are modernized demolition initiator (MDI) components and explosives are primed with MDI blasting caps. It is important that the firing system is balanced. All charges must have the same distance in the shock tube from the firing point to the charge. A combination firing system consists of the MDI initiation set; either a detonating cord line or ring main; and branch lines that can be either MDI, detonating cord, or a mix of both. The combination firing system is the preferred firing system for reserved demolition targets.

WARNING: DO NOT DISPOSE OF USED SHOCK TUBES BY BURNING THEM. THE SHOCK TUBES GIVE OFF POTENTIALLY TOXIC FUMES FROM THE BURNING PLASTIC.

1. Construct a stand-alone firing system.
  - a. Identify the firing point.
  - b. Emplace and secure the explosive charges on the target.
  - c. Begin with the set of charges furthest from the firing point and place a sandbag or other easily identifiable marker over the M12 blasting cap.
  - d. Unreel the M12 transmission line toward the next set of charges in the direction of the firing point.

NOTE: Use an M11 branch line when the distance is less than 30 feet.

- e. Place the shock tube of the first M12 in the blasting cap holder of the second M12. Cover the holder with a sandbag or another easily identifiable marker.

NOTE: Do not close the hinged flap of the holder.

- f. Unreel the second M12 transmission line toward the third set of charges in the direction of the firing point.
- g. Place the shock tube of the second M12 in the blasting cap holder of the third M12. Cover the holder with a sandbag or another easily identifiable marker.

NOTE: Continue this process for each set of charges.

WARNING: ENSURE THAT THE FIRING SYSTEM IS BALANCED. THE SHOCK WAVE IN THE SHOCK TUBE MUST TRAVEL THE SAME DISTANCE TO ALL CHARGES TO EFFECTIVELY PREVENT A MISFIRE.

- h. Unreel the last M12 transmission line toward the firing point, from the set of charges closest to it (Figure 051-193-1310-1).

Performance Steps

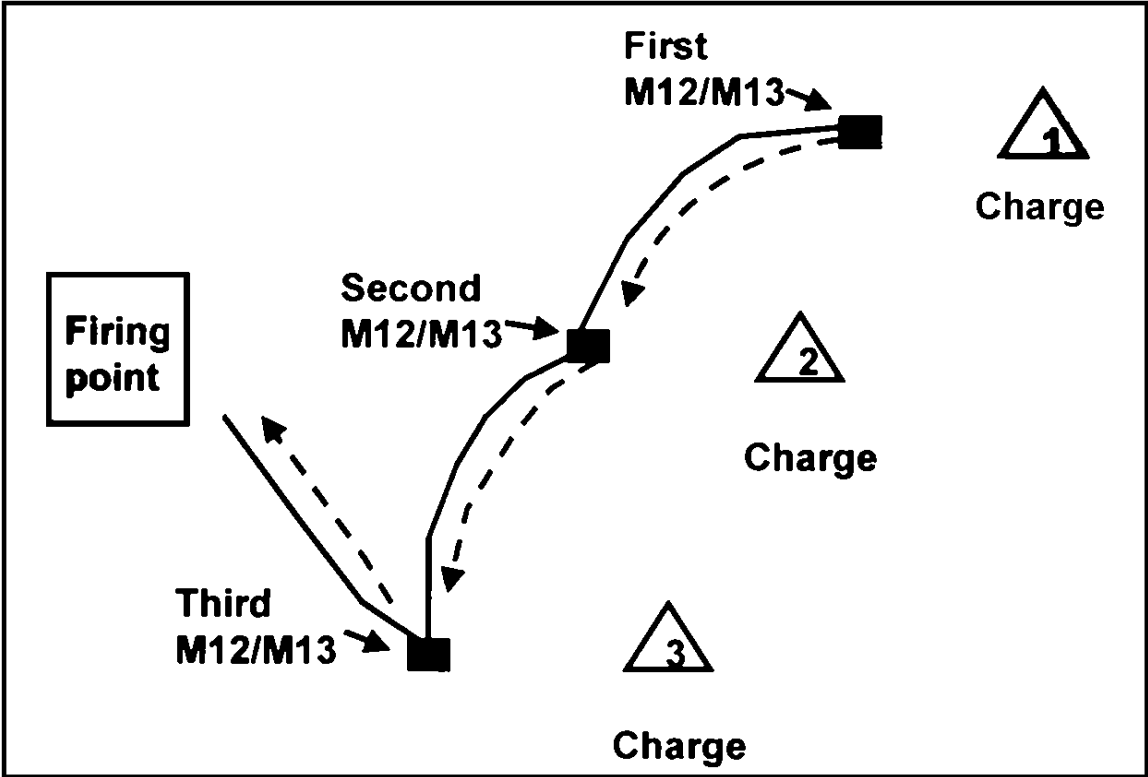

Figure 051-193-1310-1  
Transmission line to firing line

- i. Lay out at each set of charges the M11 or M16 branch line from the charges to be primed toward the transmission line blasting cap holder. Ensure that the M11 or M16 blasting caps are underneath a sandbag or another easily identifiable marker (Figure 051-193-1310-2).

Performance Steps

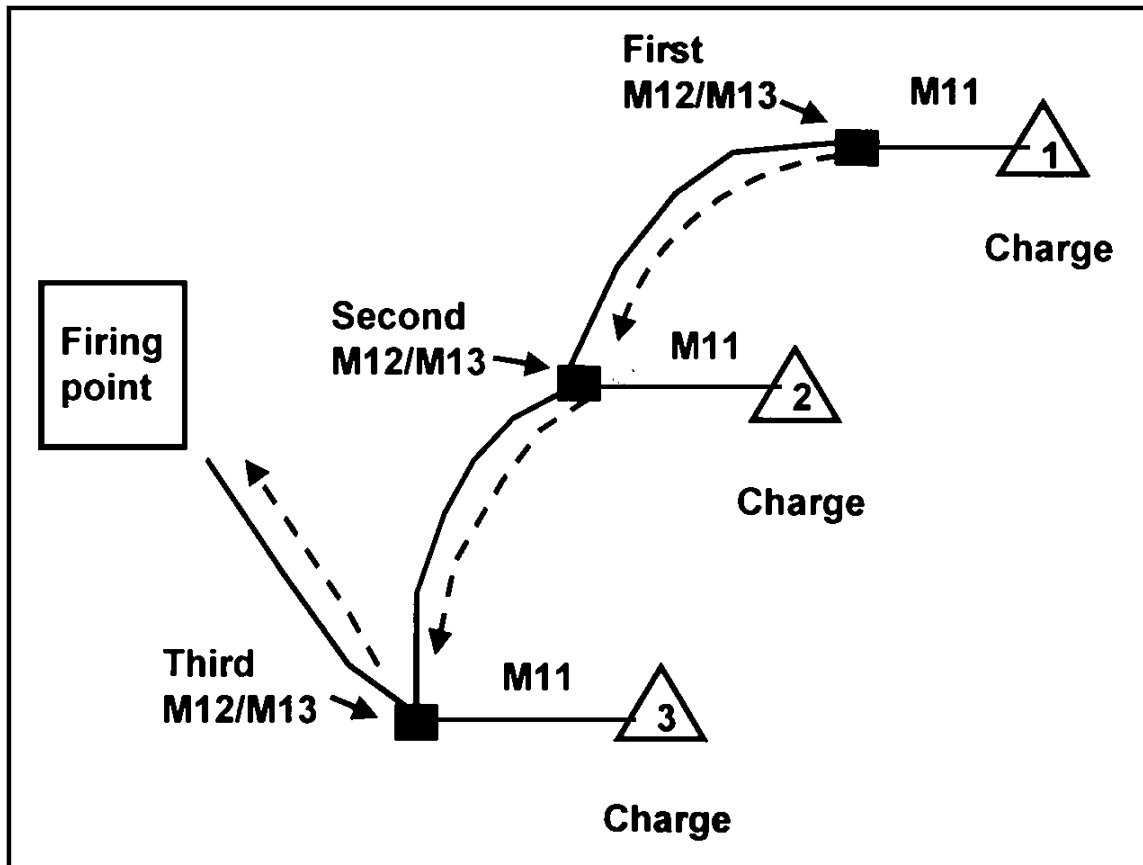

Figure 051-193-1310-2  
Branch line toward transmission line

- j. Remove the sandbag at each transmission line blasting cap holder and insert the branch line(s) into the transmission line blasting cap holder. Secure the transmission line and branch line(s) by taping the connector closed.

NOTE: No more than five M11 or M16 branch lines can be connected to the transmission line's blasting cap holder. If there are more than five charges, group the branch lines from the charges and connect them to the M9's blasting cap holder using an M11 or M16 branch line.

NOTE: Secure all the sandbags near the firing point.

- k. Use the M11 or M16 blasting caps to prime the explosive charges.
- l. Return to the firing point and construct the initiation set(s) and prepare to initiate the system (Figure 051-193-1310-3).

Performance Steps

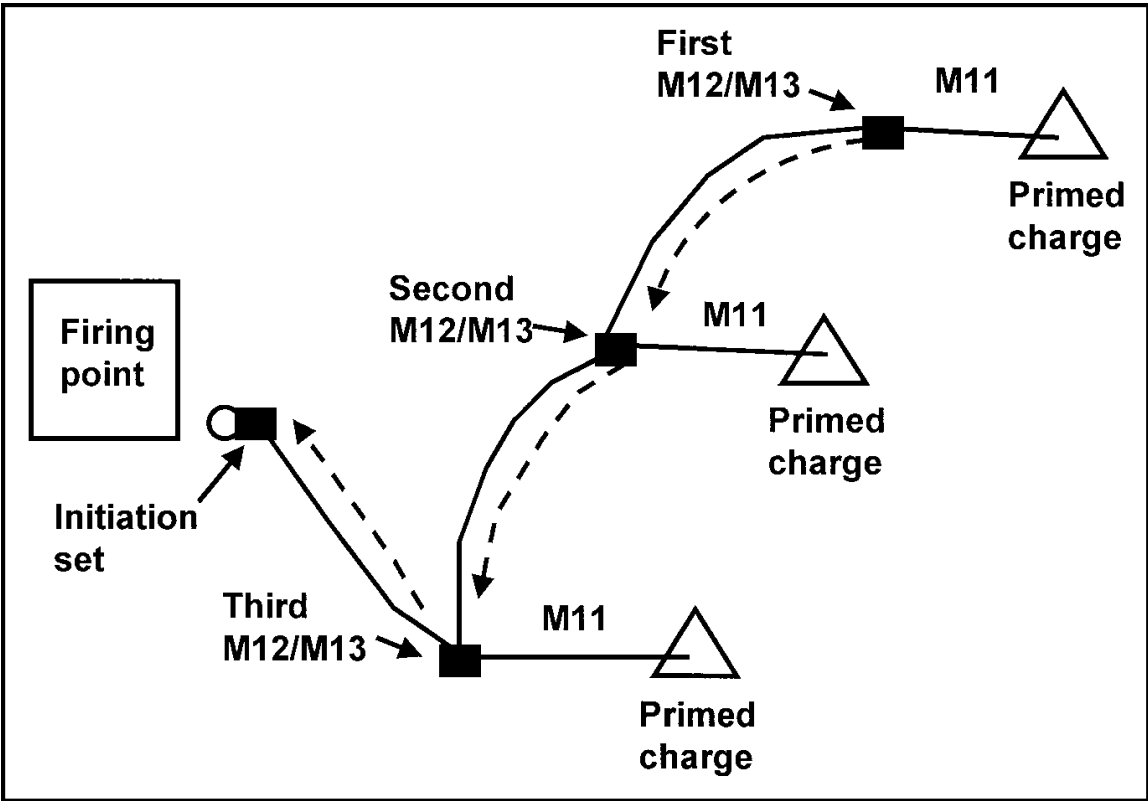

Figure 051-193-1310-3  
Initiate system

- 2. Construct a combination firing system.
  - a. Identify the firing point.
  - b. Emplace and secure explosive charges on the target.
  - c. Construct the detonating-cord line main or ring main.
    - (1) Line main. Lay the desired amount of detonation cord in a straight line between the charges, from the furthest charge back toward the firing point (Figure 051-193-1310-4).

**Performance Steps**

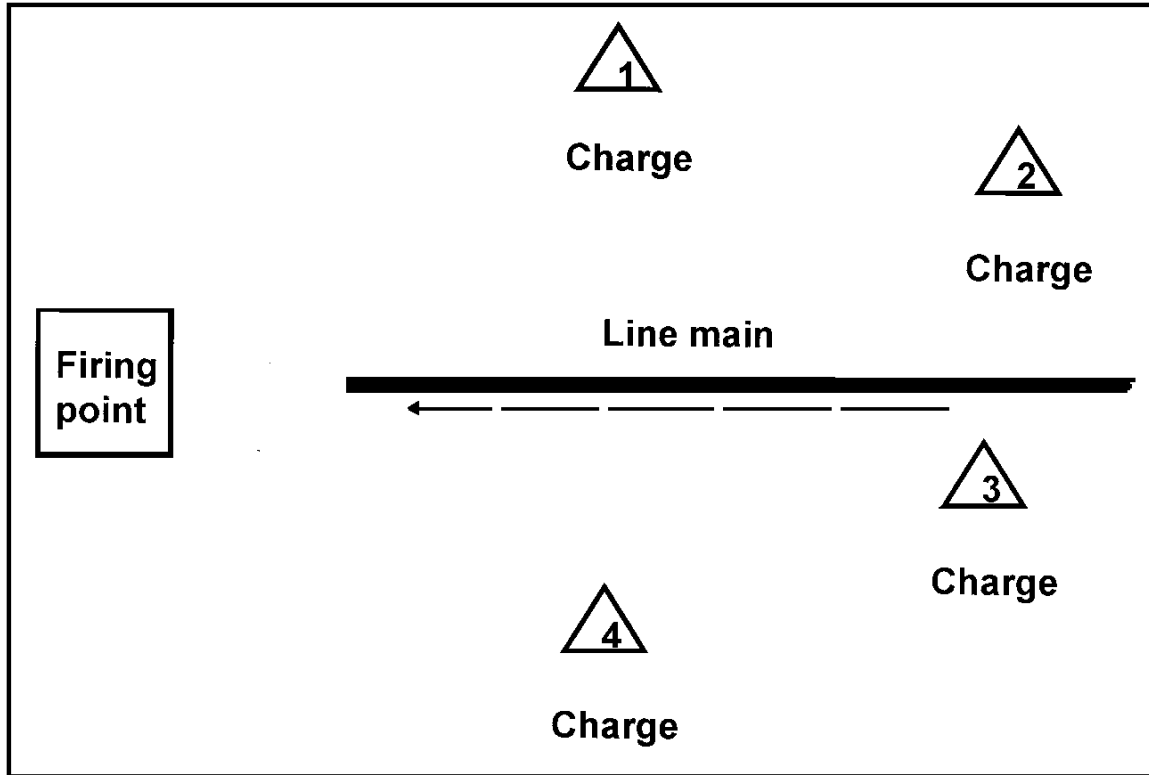

Figure 051-193-1310-4  
Line main

- (2) Ring main.
  - (a) Method One. Lay out the desired amount of detonating cord and form a loop. Attach the loop to itself with a girth hitch and an extra turn (Figure 051-193-1310-5).

Performance Steps

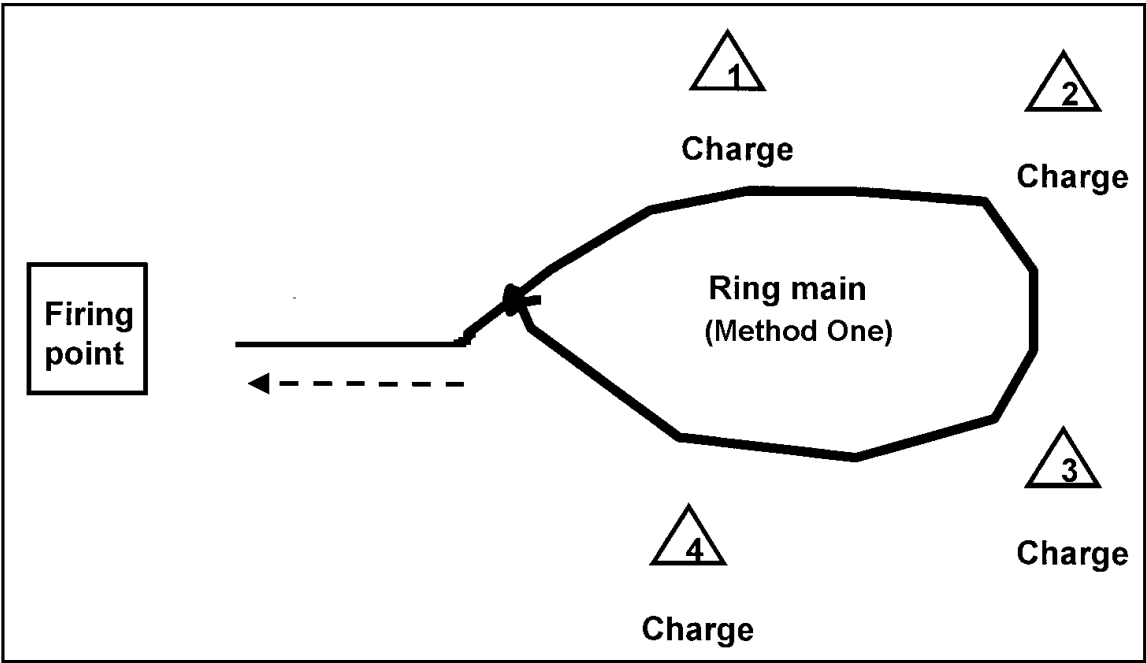

Figure 051-193-1310-5  
Ring main (method one)

- ( b) Method Two. Lay out the desired amount of detonating cord and form a U-shape. Lay another piece of detonating cord across the open end of the U-shape and attach the crossover ends to the U-shape with a girth hitch and an extra turn (Figure 051-193-1310-6).

**Performance Steps**

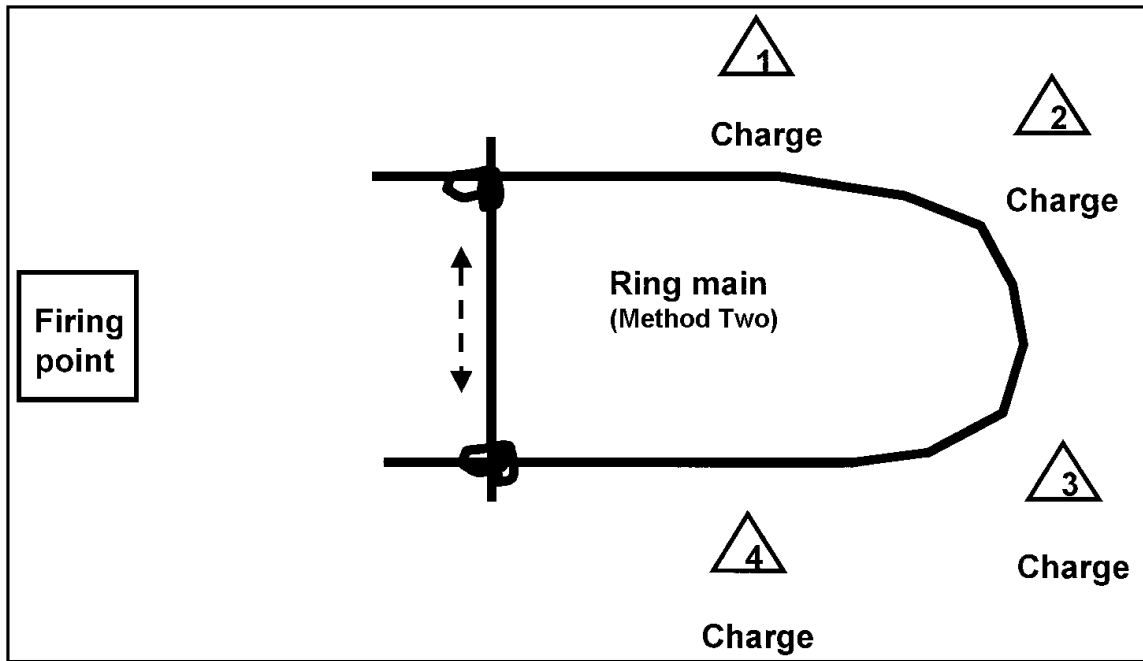

Figure 051-193-1310-6  
Ring main (method two)

- d. Place the M12 or M13 blasting caps underneath a sandbag or another easily identifiable marker at the connection between the detonating-cord line main or ring main.
- e. Unreel the M12 or M13 transmission line to the firing point.
- f. Connect the branch lines.

NOTE: Branch lines must be connected perpendicular to the line main or ring main. Avoid kinks and crossing lines. Curves and angles should not be sharp. Any number of branch lines may be connected to a line main or ring main. Ensure that there is at least one foot of space between each branch-line connection. Do not connect the branch lines at the point where the ring main is connected.

- (1) Prime the explosive with detonating cord. Connect the branch line from the explosive to the line main or ring main with a girth hitch and an extra turn or an M1 detonating-cord clip. Figures 051-193-1310-7 and 051-193-1310-8 show the two methods of connection.



Performance Steps

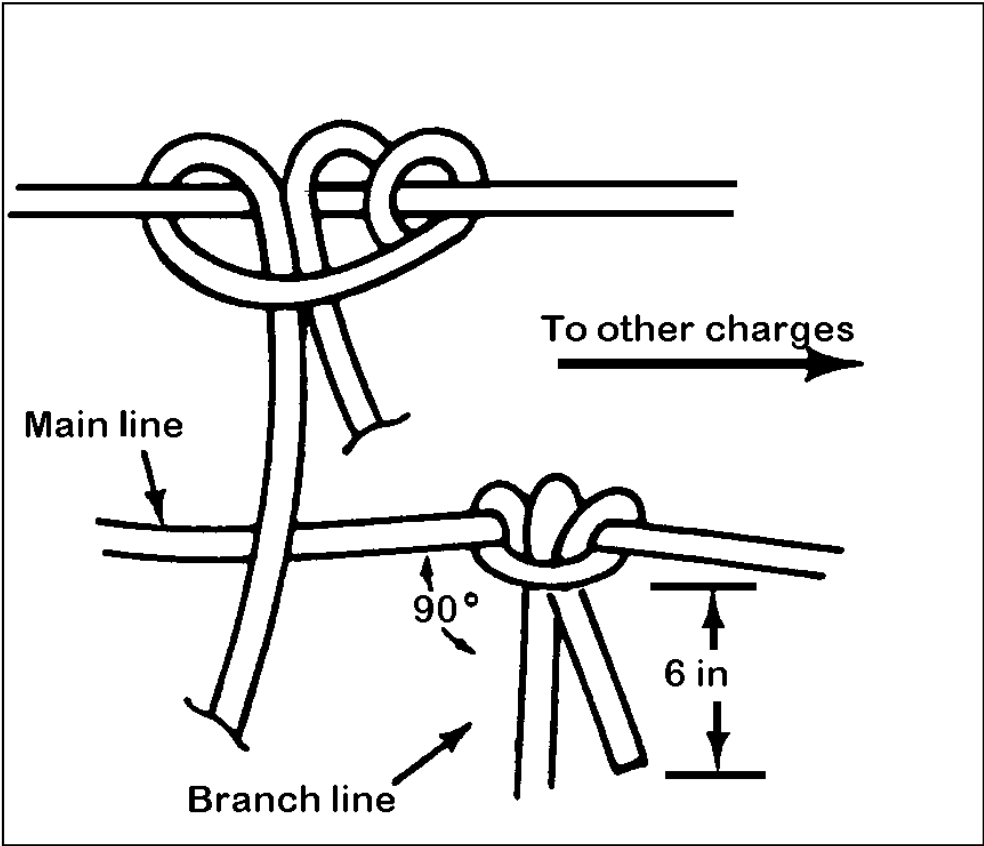

Figure 051-193-1310-7  
Girth hitch with extra turns

**Performance Steps**

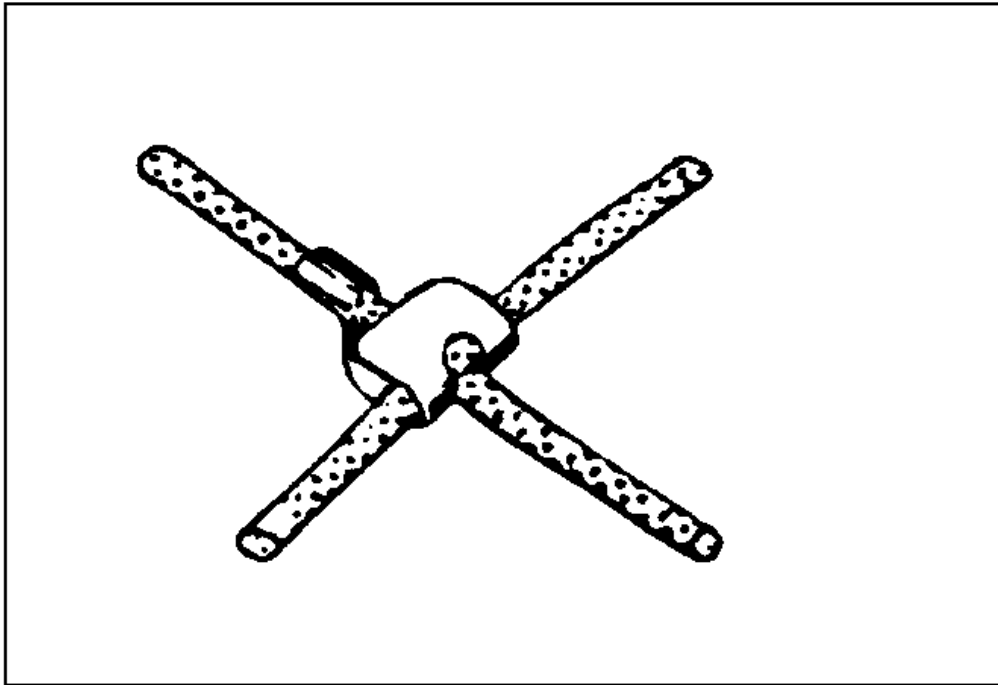

Figure 051-193-1310-8  
M1 detonating-cord clip

- (2) Use the J-hook of the M11 or M16 branch line and wrap the shock tube around and through the J-hook and pull it tight. This prevents the J-hook from slipping. Clip the J-hook to the detonating-cord line main or ring main (Figures 051-193-1310-9 and 051-193-1310-10). Prime the explosive with a M11 or M16 blasting cap.

Performance Steps

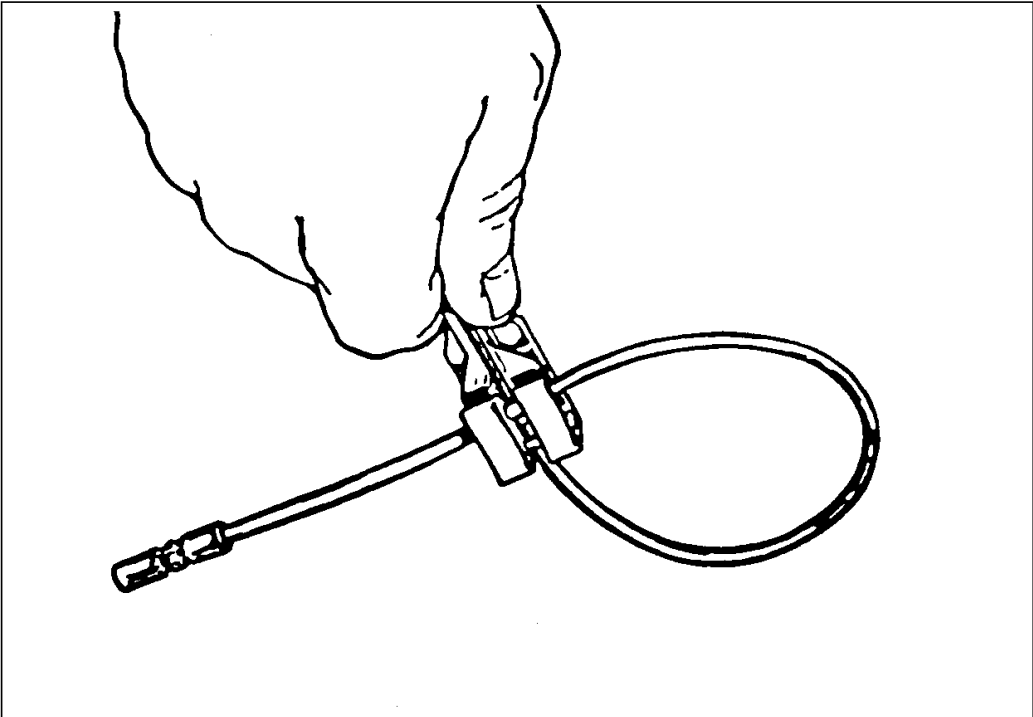

Figure 051-193-1310-9  
J-hook self loop

**Performance Steps**

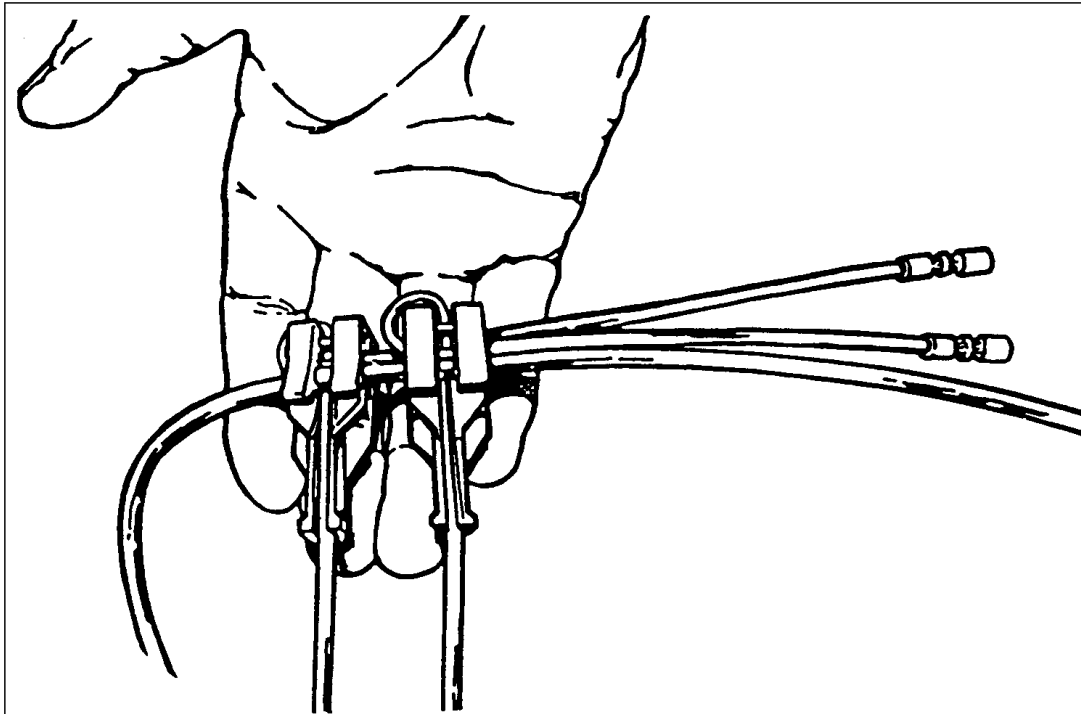

Figure 051-193-1310-10  
J-hook to the detonating cord

- g. Lay out an M11 or M16 transmission line from the end of the detonation-cord line main or ring main to the M12 or M13 transmission line plastic connector. Ensure that the M11 or M16 blasting caps are underneath a sandbag.
- h. Remove the M12 or M13 plastic connector from underneath the sandbag. Insert the M11 or M16 shock tube to the connector and secure the connection with tape (Figure 051-193-1310-11).

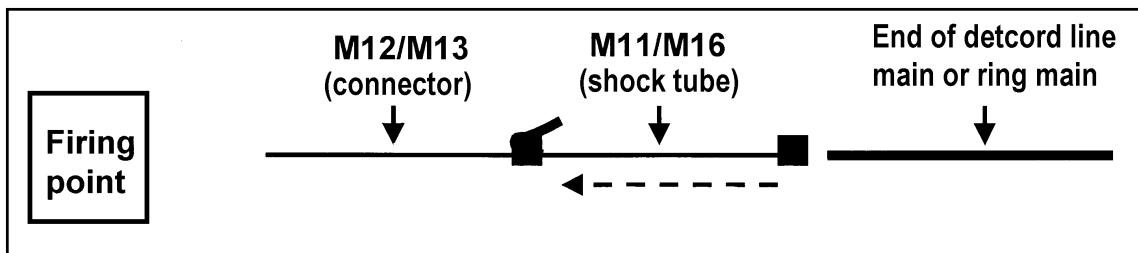

Figure 051-193-1310-11  
M11 to M12/M13

- i. Remove the M11 or M16 blasting cap from underneath the sandbag. Insert the blasting cap into the blasting cap slot of an M9 holder. Close the small hinged flap, loop the end of the detonating-cord line main or ring main into the M9 holder, close the hinged flap, and secure the connection with tape (Figure 051-193-1310-12).

Performance Steps

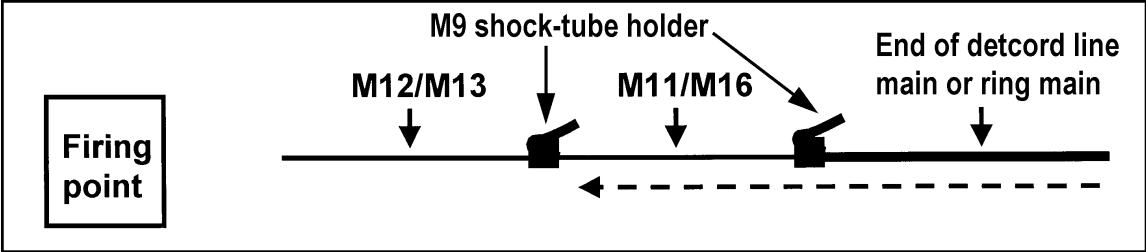

Figure 051-193-1310-12  
Transmission line to the detonating cord

NOTE: Secure all sandbags near the firing point.  
j. Return to the firing point. Construct the initiation set(s) and prepare to initiate the system (Figures 051-193-1310-13 and 051-193-1310-14).

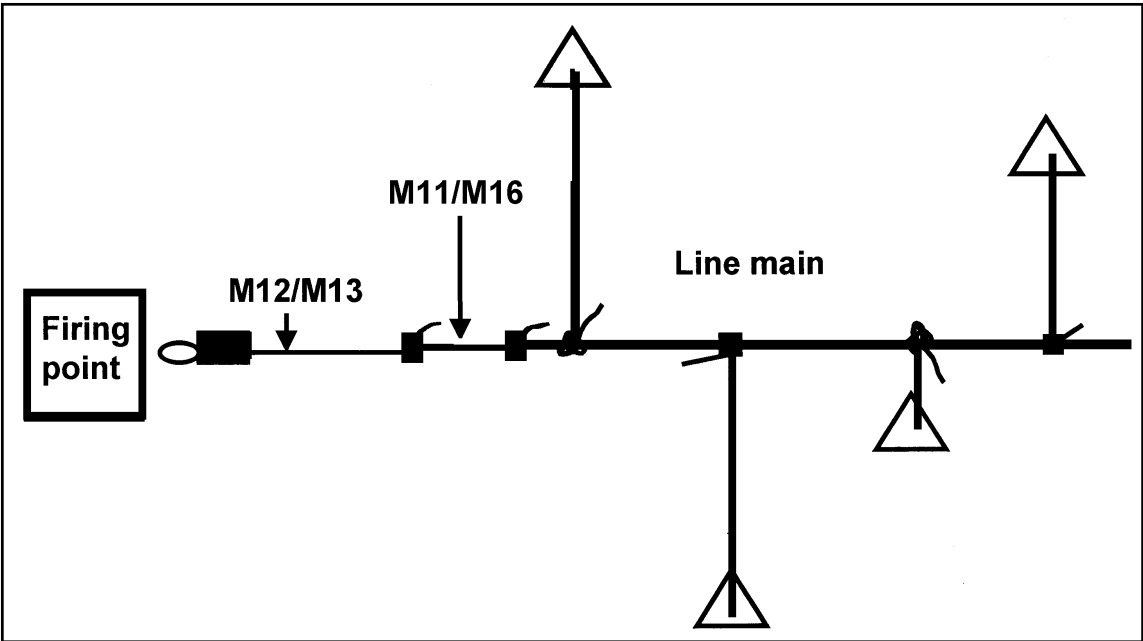

Figure 051-193-1310-13  
Line main

**Performance Steps**

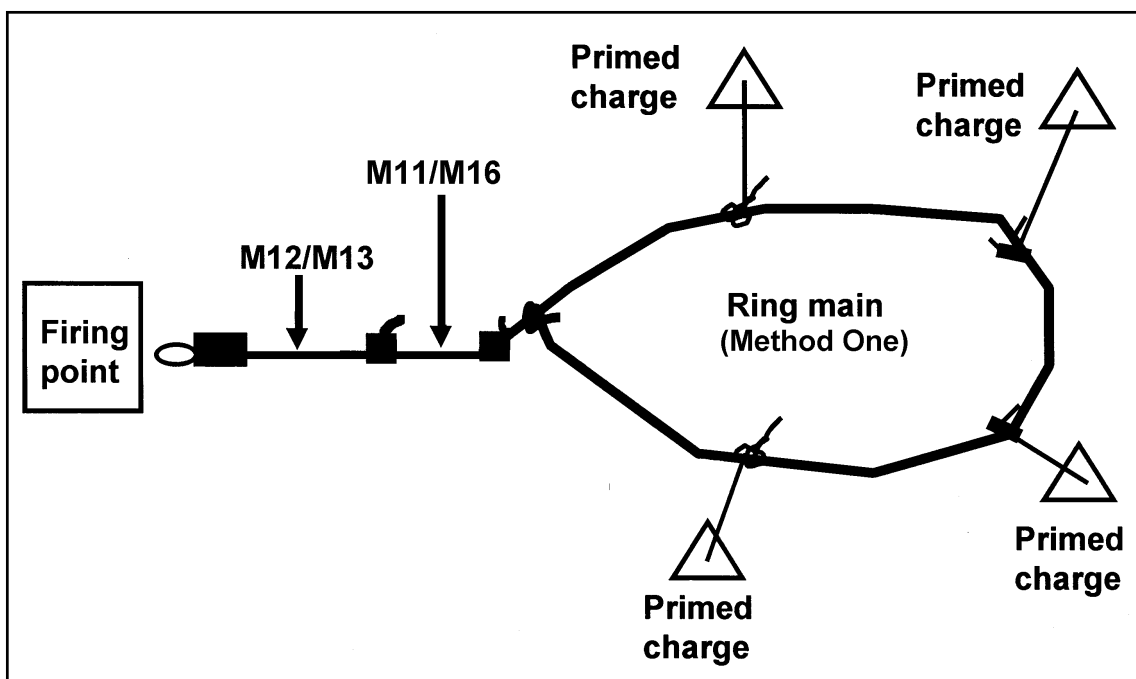

Figure 051-193-1310-14  
Ring main

NOTE: Charges are primed with detonating cord or MDI. Branch lines are connected with a girth hitch with an extra turn, M1 clip, or J-hook.

**Evaluation Preparation:** Set up: Provide the soldier with the items listed in the condition statement. Ensure that the soldier is evaluated on the construction of the firing system and not on the priming methods or initiating sets. Use inert demolitions for this evaluation. NOTE: With approval from the site noncommissioned officer in charge (NCOIC), the evaluator may evaluate the soldier on three tasks at one station in sequence: construct demolition firing systems, prime military explosives, and construct demolition initiation sets. Ensure that all conditions and standard statements are read and understood by the evaluated soldier before evaluation. Brief soldier: Tell the soldier to construct a stand-alone firing system or a combination firing system. NOTE: Ensure that the soldier understands what he will be evaluated on before the evaluation.

**Performance Measures**

1. Constructed a stand-alone firing system.
2. Constructed a combination firing system.

**Results**

P F  
P F

**Evaluation Guidance:** Score the soldier GO if all steps are passed (P). Score the soldier NO-GO if any step is failed (F). If the soldier fails any step, show him how to do it correctly.

**References**  
Required

**Related**  
FM 5-250

**PRIME MILITARY EXPLOSIVES**  
**051-193-1311**

**Conditions:** As a combat engineer squad member in a field environment, given various types of military explosives, detonating cord, modernized demolition initiators (MDIs) with high-strength blasting caps, a demolition knife, M2 crimpers, string, and adhesive tape.

**Standards:** Primed the explosives, in sequence, without causing premature detonation.

**Performance Steps**

1. Prime military explosives with detonating cord. Use the methods below to prime (TNT) blocks with detonating cord.
  - a. Common Method: Lay one end (1-foot length) of detonating cord at an angle across the explosive. Wrap the running end around the block three turns, laying the wraps over the standing end. On the fourth wrap, slip the running end under all the wraps, parallel to the standing end, and draw the wraps tight. This forms a clove hitch with two extra turns (Figure 051-193-1311-1).

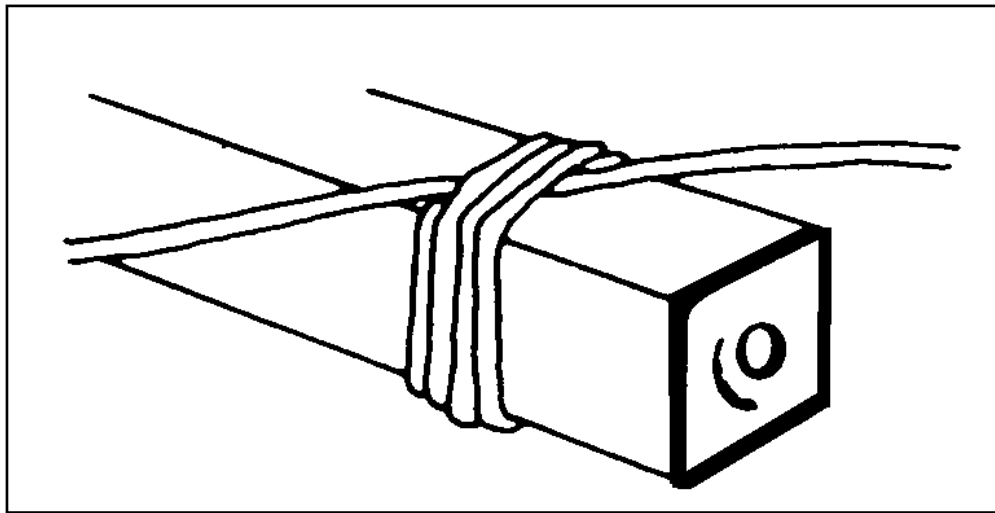

Figure 051-193-1311-1  
Common method

- b. Alternate Method: Place a loop of detonating cord on the explosive. Leave enough length on the end to make four turns around the block and loop with the remaining end of the detonating cord. Ensure that the first wrap crosses over the standing end of the loop. Work toward the closed end of the loop, passing the free end of the detonating cord through the loop. Pull the running end through the eye of the loop and tighten it (Figure 051-193-1311-2).

**Performance Steps**

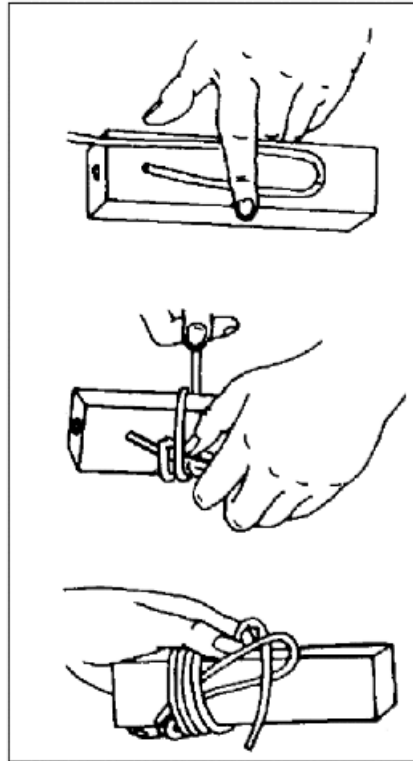

Figure 051-193-1311-2  
Alternate method

2. Prime M112 (composition C4 [C4]) demolition blocks with detonating cord.
  - a. Form either a Uli, a double overhand, or a triple roll knot (Figure 051-193-1311-3).



## Performance Steps

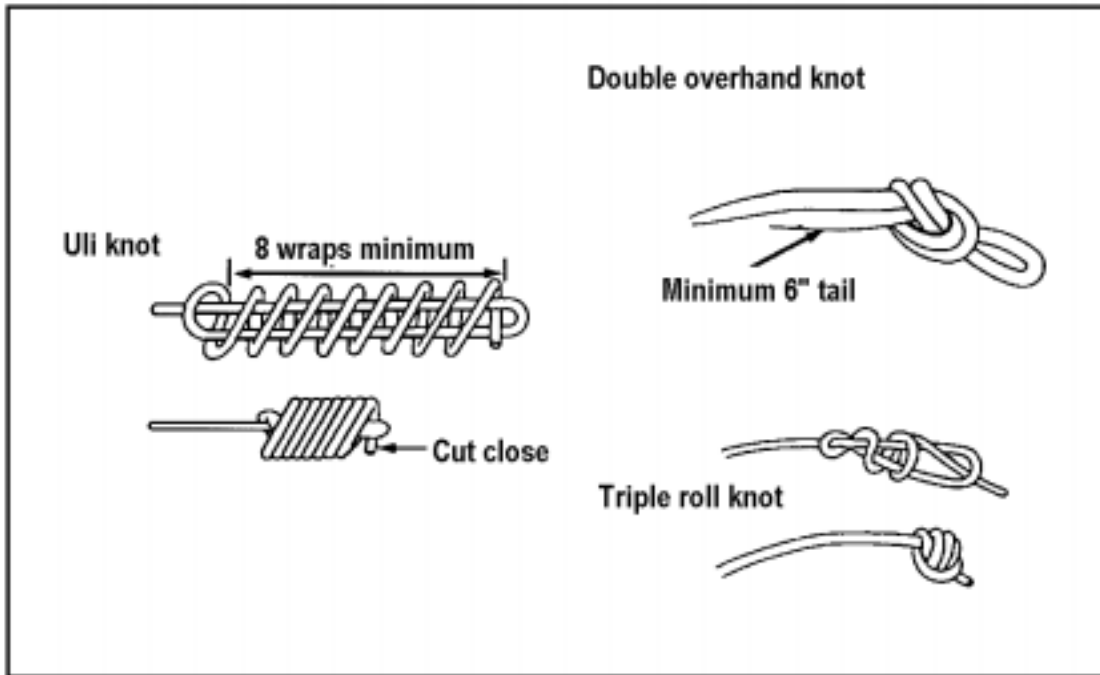

Figure 051-193-1311-3  
Detonating cord knots

- b. Cut an L-shaped portion of explosives, but leave it connected to the explosive. Ensure that the space is large enough to insert the knot you formed (Figure 051-193-1311-4).  
**CAUTION: USE A SHARP, NONSPARKING KNIFE ON A NONSPARKING SURFACE TO CUT THE EXPLOSIVES.**
- c. Insert the knot into the L-shaped cut and push the explosive over the knot. Ensure that there is at least one-half inch of explosive on all sides of the knot. Strengthen the primed area by wrapping it with tape.

**Performance Steps**

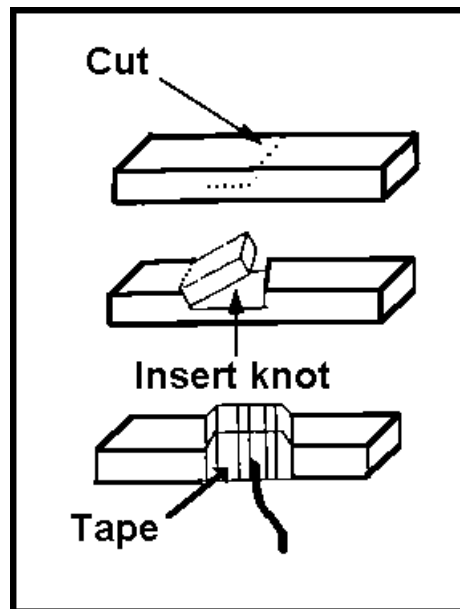

Figure 051-193-1311-4  
C4, L-shape cut

3. Prime M118 and M186 demolition charges (sheet charges) with detonating cord (Figure 051-193-1311-5).

## Performance Steps

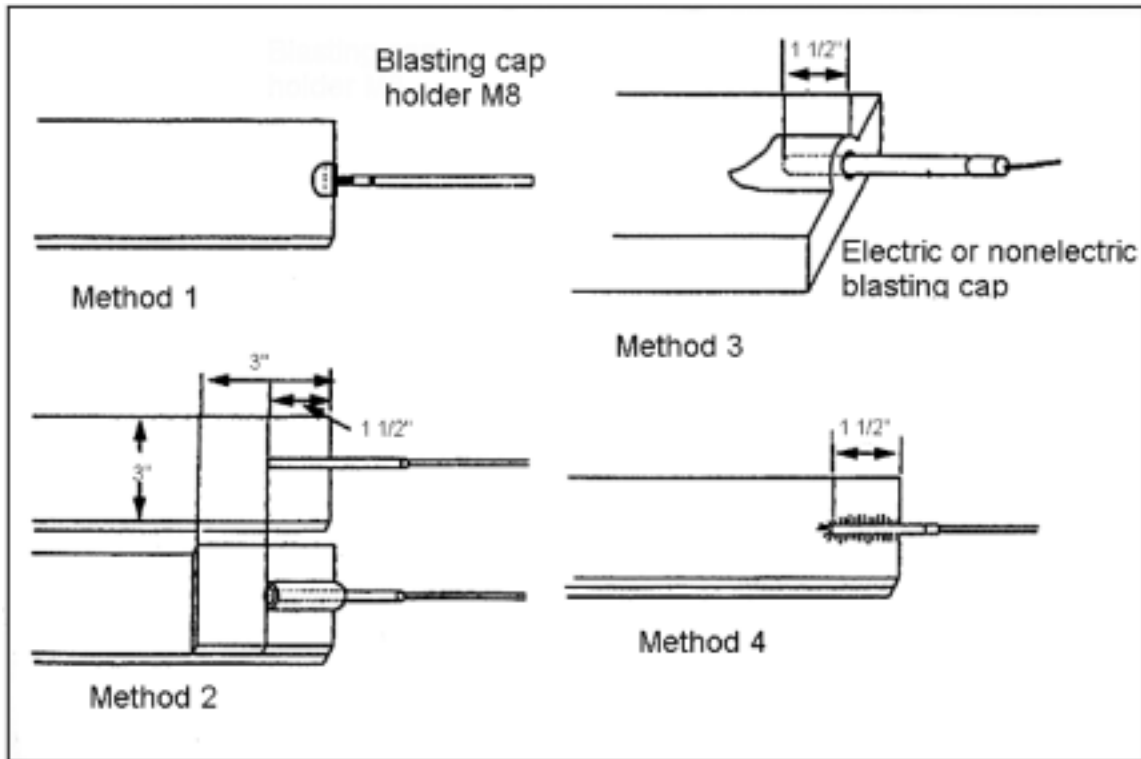

Figure 051-193-1311-5  
Demolition charges

- a. Form a Uli, double overhand, or tripple roll knot.
  - b. Insert the knot between two sheets of explosive or place the knot on top of the sheet explosive. Secure it with a small strip of sheet explosive. The knot must be covered on all sides with at least one-half inch of explosive.
4. Prime dynamite with detonating cord.
- a. Use the M2 crimpers and start one inch from either end of the dynamite charge and punch four equally spaced holes through the dynamite cartridge (Figure 051-193-1311-6).
- NOTE: Rotate the cartridge 180 degrees after punching each hole to keep the holes parallel.
- b. Lace the detonating cord through the holes in the same direction the holes were punched (Figure 051-193-1311-6).
- CAUTION: DO NOT PULL THE DETONATING CORD TOO TIGHT. THE CARTRIDGE WILL BREAK.
- c. Secure the detonating cord tail by passing it between the detonating cord lace and the dynamite charge (Figure 051-193-1311-6).

**Performance Steps**

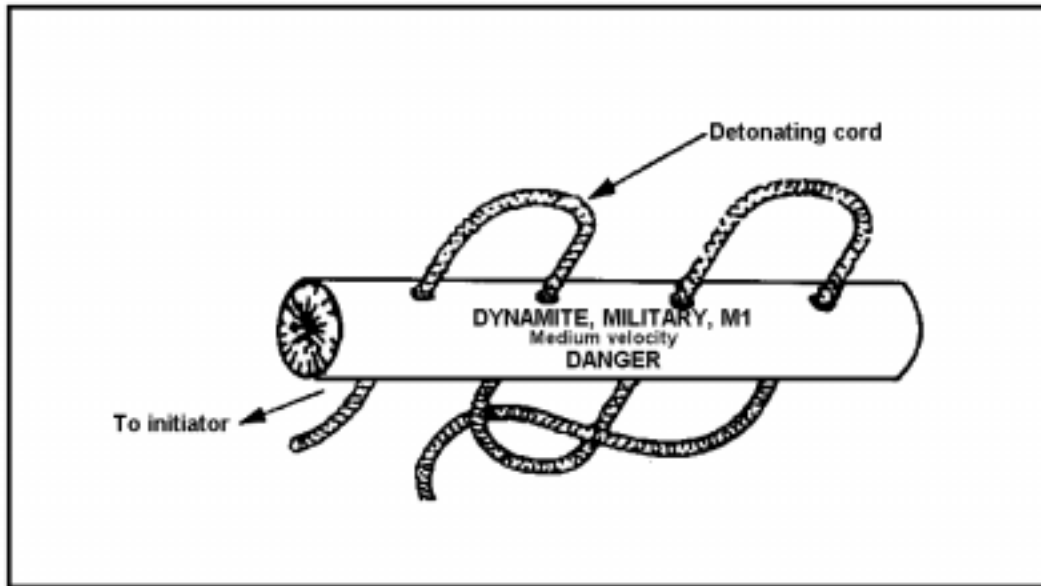

Figure 051-193-1311-6  
Priming dynamite

5. Prime a 40-pound cratering charge.

NOTE: Because the cratering charge is primarily an underground charge, prime it only with C4 primed with detonating cord. Dual prime to protect against misfires.

- a. Prime a 40-pound, composition H6 cratering charge.
  - (1) Prime two packages of C4 with detonating cord.
  - (2) Place the primed packages parallel to the cratering charge, on opposite sides of it, and flush with the top.
  - (3) Firmly hold the packages in place with 100-miles-per-hour tape (Figure 051-193-1311-7).

## Performance Steps

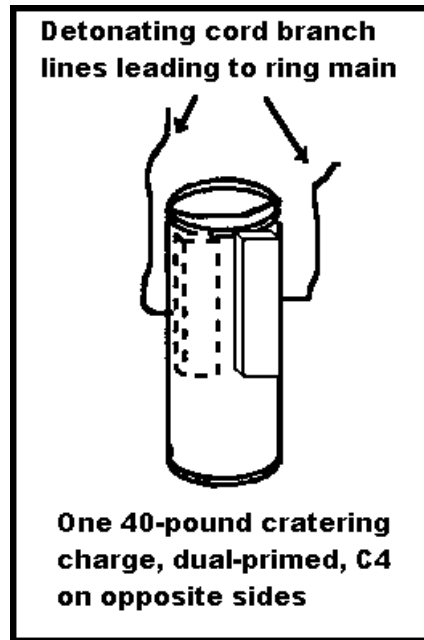

Figure 051-193-1311-7  
H6 cratering charge

NOTE: Instructions and markings on the canister indicate the exact placement of the primed C4.

NOTE: Ensure that the detonating cord branch lines (from the C4) are long enough to reach the detonating-cord line main or ring main.

NOTE: Place tape on the detonating cord from the cratering charge one foot up to aid in clearing possible misfires.

b. Prime a 40-pound ammonium-nitrate cratering charge.

**CAUTION: AMMONIUM NITRATE IS HYGROSCOPIC AND INEFFECTIVE WHEN WET. THEREFORE, INSPECT THE METAL CONTAINER FOR DAMAGE OR RUST. DO NOT USE DAMAGED OR RUSTY CHARGES.**

- (1) Pass the end of the detonating cord through the tunnel on the side of the cratering charge.
- (2) Tie an overhand knot with a 6-inch tail at the lower end of the length of the detonating cord.
- (3) Take a preprimed 1-pound block of explosive (C4 or TNT) and tape the charge along the center of the cratering charge (Figure 051-193-1311-8).

**Performance Steps**

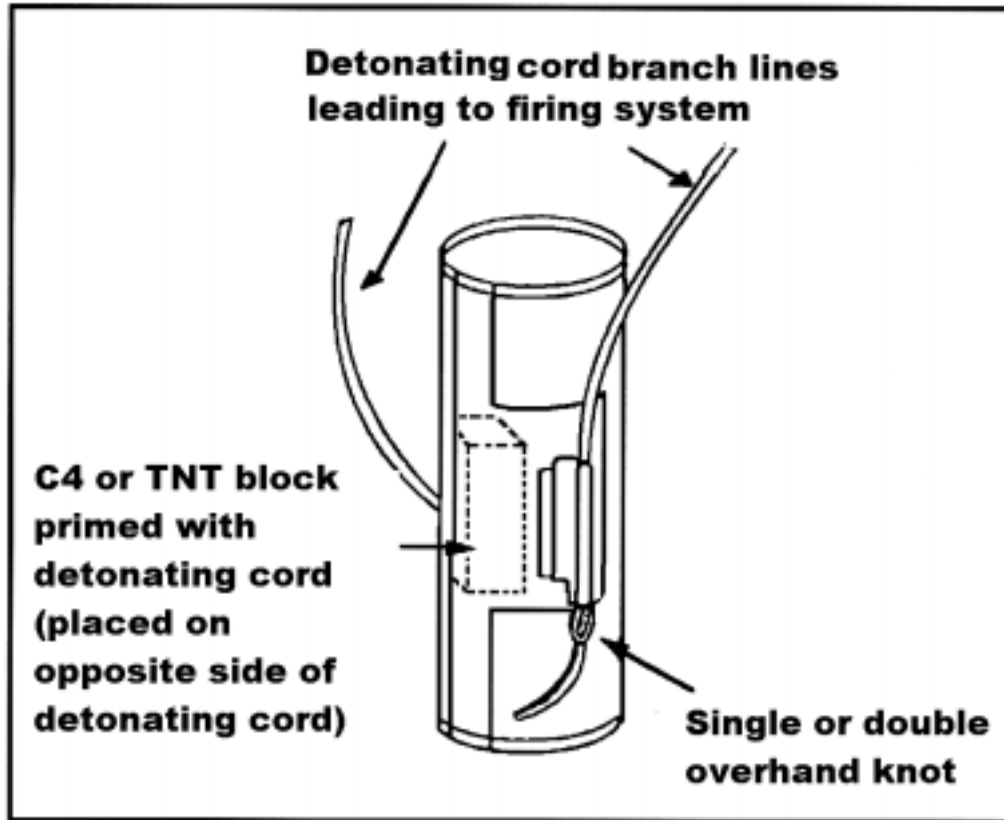

Figure 051-193-1311-8  
Prime cratering charge

6. Prime a bangalore torpede with detonating cord.

**CAUTION:** USE EXACTLY EIGHT WRAPS TO PRIME THE TORPEDO. TOO MANY WRAPS WILL EXTEND THE DETONATING CORD PAST THE BOOSTER CHARGE HOUSING, POSSIBLY CAUSING THE TORPEDO TO BE CUT WITHOUT DETONATION. TOO FEW WRAPS MAY CAUSE THE TORPEDO TO ONLY BE CREASED WITHOUT DETONATION.

- a. Wrap the detonating cord eight times around the end of the section, just below the bevel, and pull the knot tight.

**NOTE:** Never use the short end (tail) of the detonating cord to initiate the torpede. Initiation must come from the running end of the detonating cord.

- b. After pulling the knot tight, insert the short end of the detonating cord into the cap well, and secure it with tape when needed (Figure 051-193-1311-9).

## Performance Steps

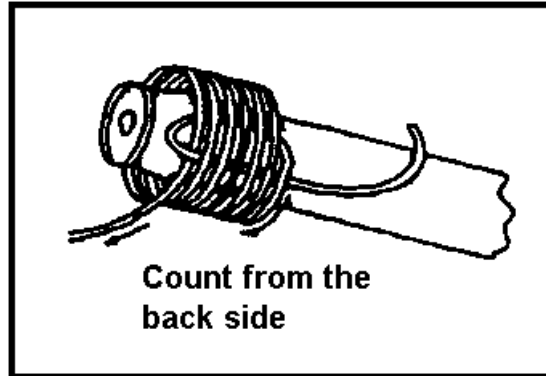

Figure 051-193-1311-9  
Bangalore torpedo

**WARNING: NEVER USE THE SHORT END OF THE DETONATING CORD TO INITIATE THE TORPEDO. INITIATION MUST COME FROM THE RUNNING END OF THE DETONATING CORD CONNECTED TO THE LINE MAIN OR RING MAIN.**

7. Prime TNT with an MDI high-strength blasting cap and an M1A4 priming adapter.
  - a. Place the blasting cap underneath a sandbag.
  - b. Use the pointed end of the M2 crimpers to punch a hole in the paper covering the cap well of the block of TNT (Figure 051-193-1311-10).

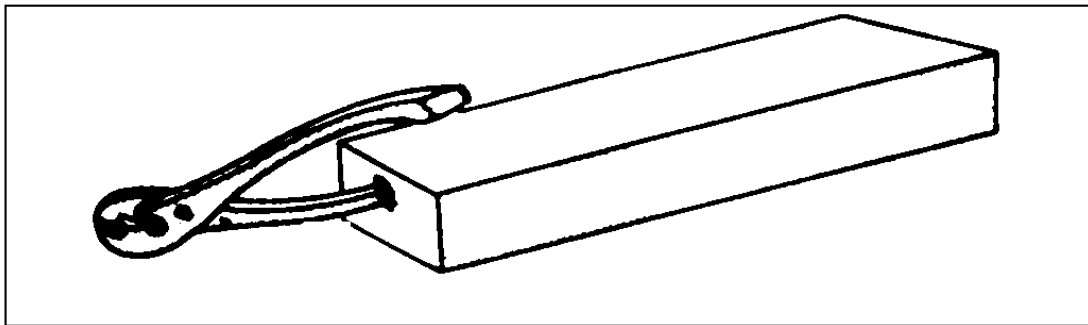

Figure 051-193-1311-10  
Demolition block

- c. Inspect the cap well to ensure that nothing is preventing the blasting cap from fully seating in the cap well of the explosive.
- d. Attach the priming adapter.

**NOTE:** The M1A4 priming adapter must be slid down the full length of the shock tube to the blasting cap.

- (1) Cut the desired amount of shock tube or cut the sealed end of the shock tube and remove the J-hook, when attached.
- (2) Slide the priming adapter onto the shock tube, threaded end first, down to the blasting cap.
- (3) Remove the blasting cap from underneath the sandbag, slide the priming adapter over the blasting cap, and place the blasting cap back underneath the sandbag.
- (4) Replace the J-hook when used.
- e. Secure the blasting cap to the TNT block.
  - (1) Remove the blasting cap from underneath the sandbag.

**Performance Steps**

- (2) Secure the blasting cap in one hand. Ensure that the cap is completely enclosed in the hand and facing down and away from the thumb (Figure 051-193-1311-11).

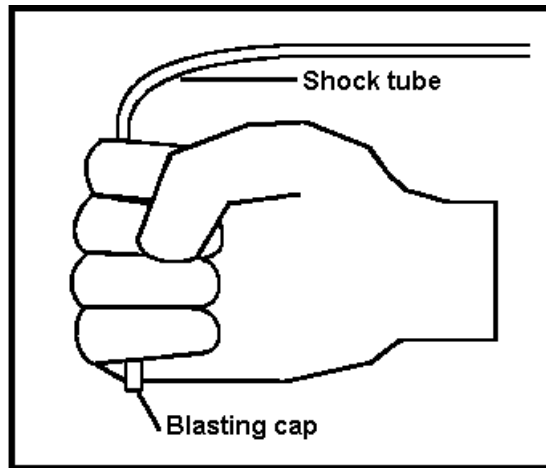

Figure 051-193-1311-11  
Holding the blasting cap

- (3) Insert the blasting cap end into the threaded cap well of the TNT (Figure 051-193-1311-12).

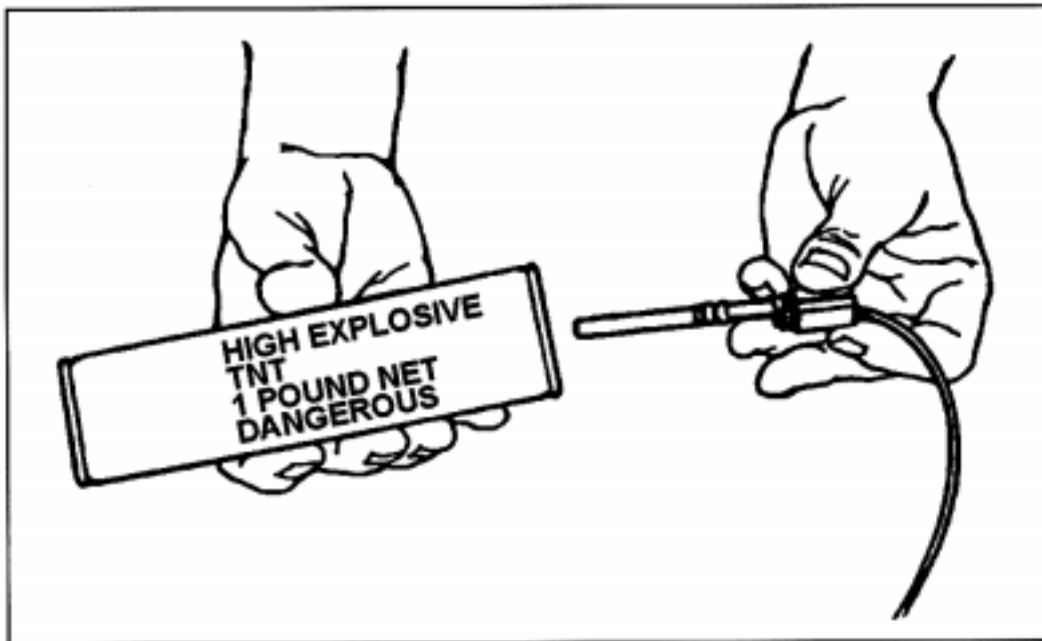

Figure 051-193-1311-12  
Inserting blasting cap in TNT

- (4) Tighten the priming adapter by screwing it into the threaded cap well.

8. Prime TNT with an MDI high-strength blasting cap using the string or tape method.



**Performance Steps**

## a. String Method.

- (1) Place the blasting cap underneath a sandbag.
- (2) Use the pointed end of the M2 crimpers to punch a hole in the paper that covers the threaded cap well of the block of TNT.
- (3) Inspect the threaded cap well to ensure that nothing is preventing the blasting cap from fully seating in the threaded cap well of the explosive.
- (4) Wrap the string around the block four times. Ensure that the tails are the same length and secure the wraps with a nonslip knot (Figure 051-193-1311-13).

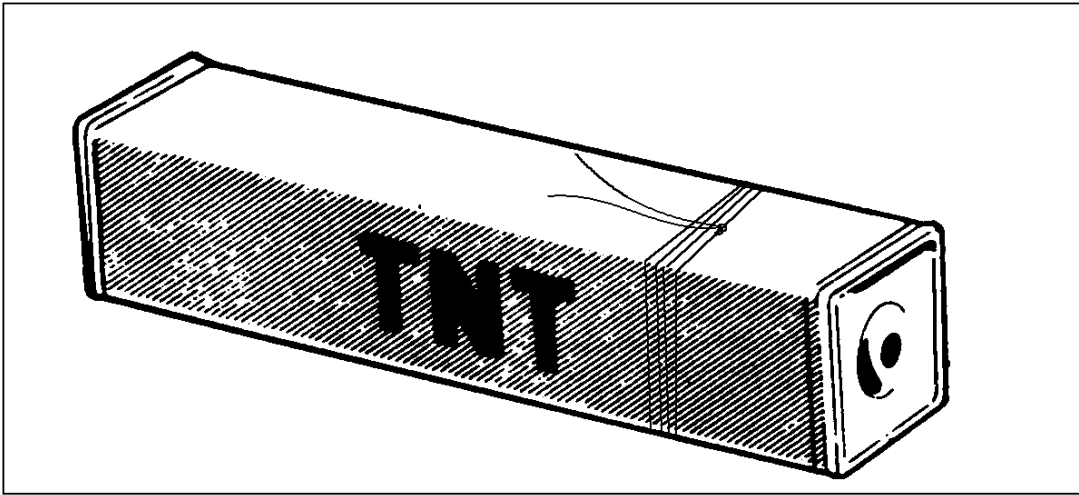

Figure 051-193-1311-13  
Tie string around TNT

- (5) Remove the blasting cap from underneath the sandbag.
- (6) Secure the blasting cap in one hand. Ensure that the cap is completely enclosed in the hand, facing down, and away from the thumb.
- (7) Insert the blasting cap end into the threaded cap well of the TNT.
- (8) Bend the shock tube over the nonslip knot and secure it with two half-hitches (Figure 051-193-1311-14).

**Performance Steps**

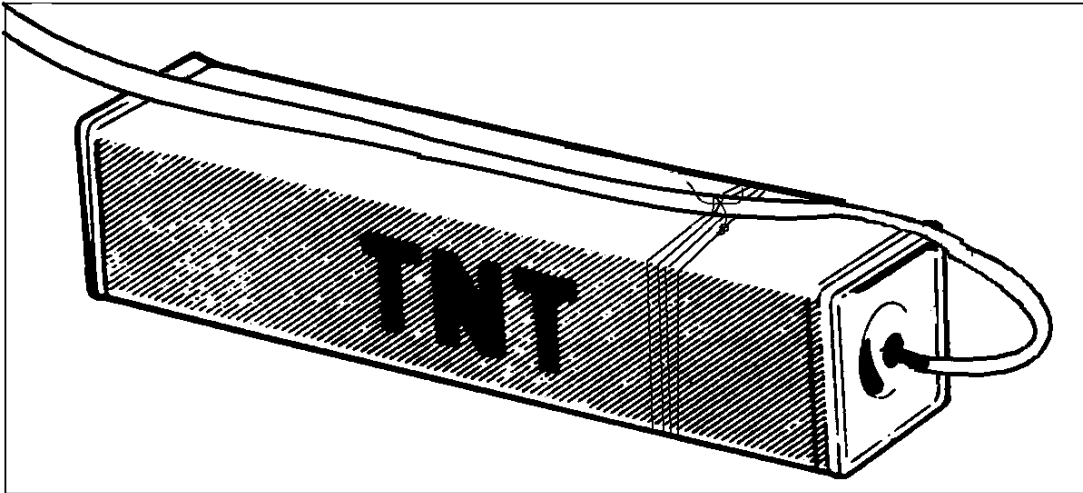

Figure 051-193-1311-14  
Secure shock tube with string

**b. Tape Method:**

- (1) Place the blasting cap underneath a sandbag.
- (2) Use the pointed end of the M2 crimpers to punch a hole in the paper that covers the threaded cap well of the block of TNT.
- (3) Inspect the threaded cap well to ensure that nothing is preventing the blasting cap from fully seating in the threaded cap well of the explosive.
- (4) Remove the blasting cap from underneath the sandbag.
- (5) Secure the blasting cap in one hand. Ensure that the cap is completely enclosed in the hand, facing down, and away from the thumb.
- (6) Insert the blasting cap end into the threaded cap well of the TNT.
- (7) Bend the shock tube over the block and secure it with electrical tape (Figure 051-193-1311-15).

**Performance Steps**

Figure 051-193-1311-15  
Secure shock tube with tape

9. Prime dynamite with an MDI high-strength blasting cap.
  - a. End-Priming Method.
    - (1) Place the blasting cap underneath a sandbag.
    - (2) Use the M2 crimpers or another nonsparking tool to make a cap well in one end of the dynamite cartridge.
    - (3) Remove the blasting cap from underneath the sandbag and insert the blasting cap into the cap well.
    - (4) Secure the blasting cap and shock tube to the cartridge with tape to hold the blasting cap firmly in place (Figure 051-193-1311-16).

**Performance Steps**

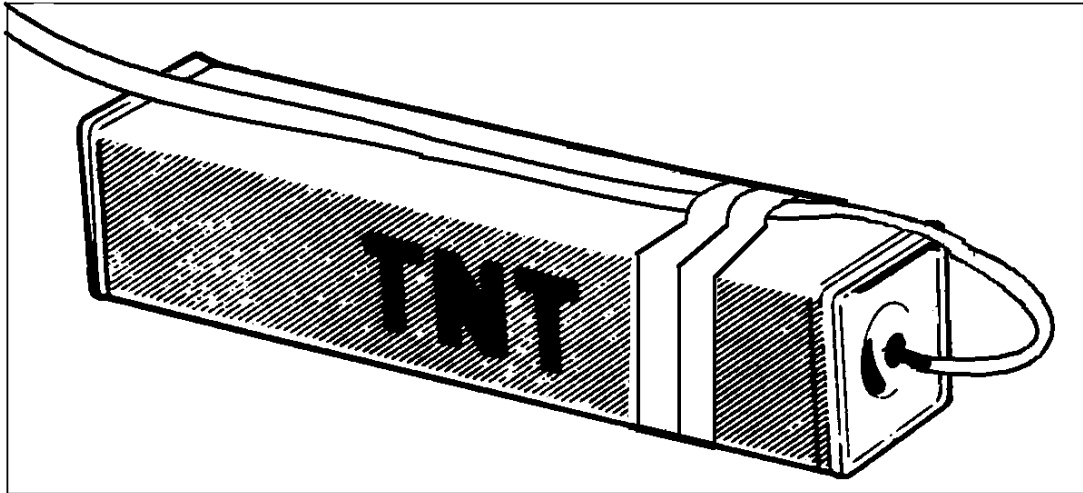
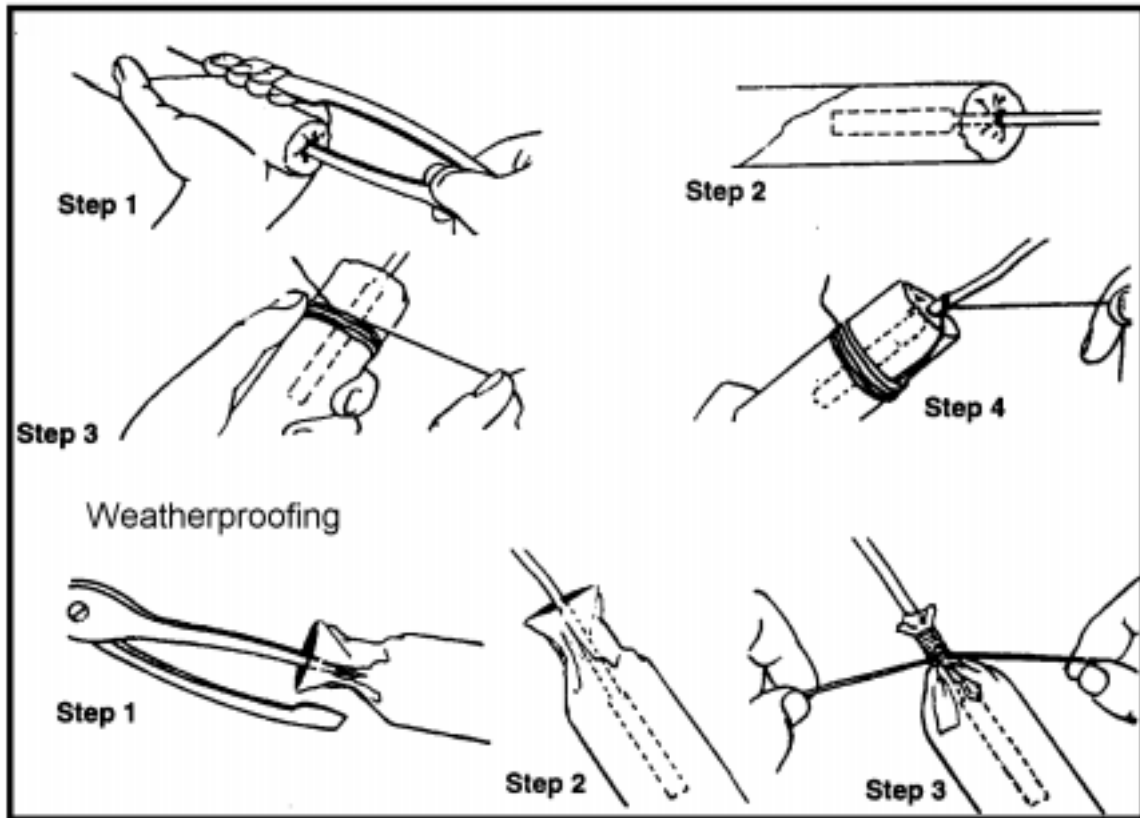

Figure 051-193-1311-16  
End-priming method

b. Side-Priming Method.

- (1) Place the blasting cap underneath a sandbag.
- (2) Use the M2 crimpers to make a cap well (about 1 1/2 inches long) in the side of the dynamite cartridge at one end. Slightly slant the cap well so the blasting cap, when inserted, will be nearly parallel to the side of the cartridge and the explosive end of the cap will be at a point nearest the middle of the cartridge.
- (3) Insert the blasting cap into the cap well.
- (4) Tie a string securely around the fuse. Then, wrap the string tightly around the cartridge, making two or three turns before tying it (Figure 051-193-1311-17).

## Performance Steps

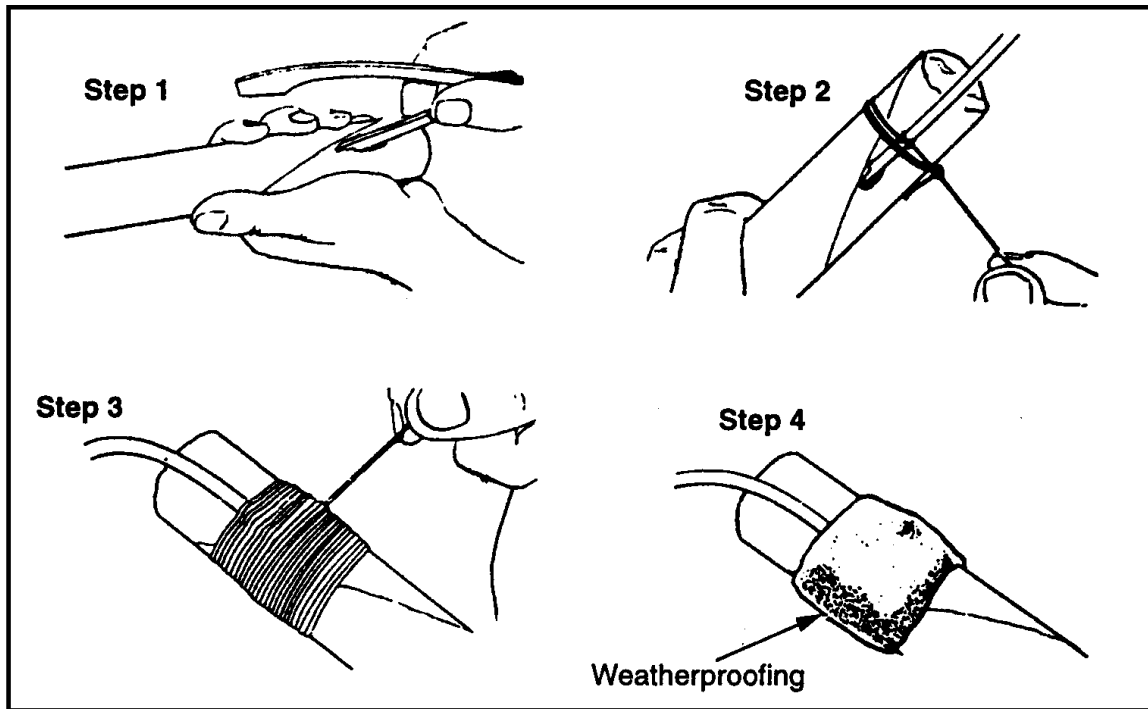

Figure 051-193-1311-17  
Side-priming method

NOTE: Weatherproof the primed cartridge by wrapping a string snugly around the cartridge, extending it an inch or so on each side of the hole to cover the hole completely. Cover the string with a weatherproof sealing compound.

10. Prime the M112 demolition block (C4) with a MDI high-strength blasting cap.
  - a. Place the blasting cap underneath a sandbag.
  - b. Use the M2 crimpers or another nonsparking tool to make a hole in one end or in the side (at midpoint) of the demolition block.

NOTE: The hole must be large enough to hold a blasting cap.

- c. Remove the blasting cap from underneath the sandbag and insert the blasting cap into the hole of the demolition block (Figure 051-193-1311-18).

**Performance Steps**

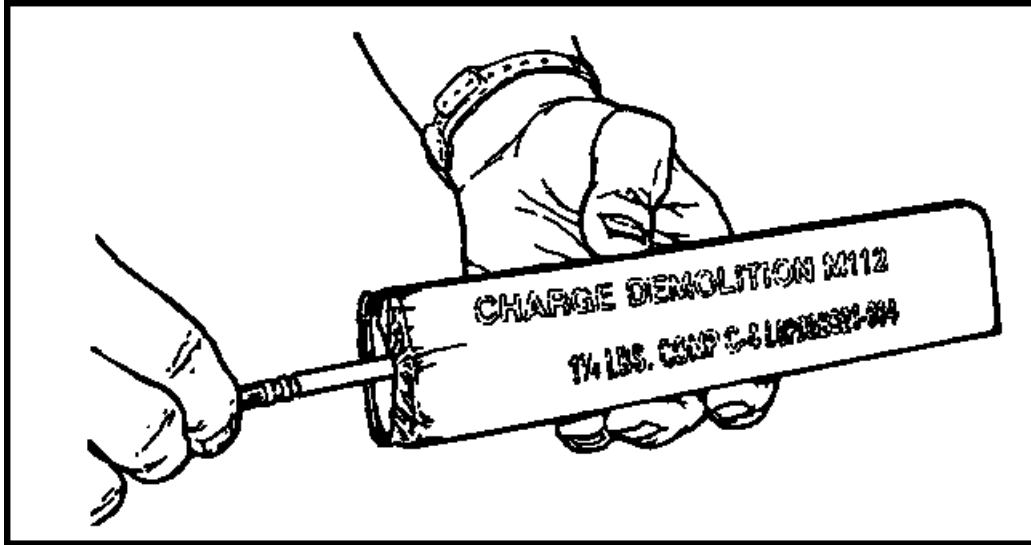

Figure 051-193-1311-18  
Prime C4 with MDI

**WARNING: DO NOT FORCE THE BLASTING CAP. IF THE BLASTING CAP DOES NOT FIT, ENLARGE THE HOLE.**

- d. Anchor the blasting cap into the block by gently squeezing the C4 plastic explosive around the cap.
- e. Use electrical tape to secure the cap in the charge.

- 11. Prime an M2A4 or M3A1 shape charge with an MDI high-strength blasting cap and an M1A4 priming adapter.

**NOTE 1:** Do not prime the charge until it is placed on the target.

**NOTE 2:** Use tape to secure the blasting cap in the threaded cap well when a priming adapter is not used.

- a. Place the blasting cap underneath a sandbag.
- b. Position the charge.
- c. Cut the desired amount of shock tube or cut the sealed end of the shock tube and remove the J-hook when attached.
- d. Slide the priming adapter onto the shock tube, threaded end first, down to the blasting cap.
- e. Remove the blasting cap from underneath the sandbag, slide the priming adapter over the blasting cap, and place the blasting cap back underneath the sandbag.
- f. Replace the J-hook when used.
- g. Remove the blasting cap from underneath the sandbag.
- h. Secure the blasting cap in one hand. Ensure that the cap is completely enclosed in the hand, facing down, and away from the thumb.
- i. Insert the blasting cap into the threaded cap well of the shape charge. Secure the blasting cap by tightening the priming adapter into the threaded cap well (Figure 051-193-1311-19).

## Performance Steps

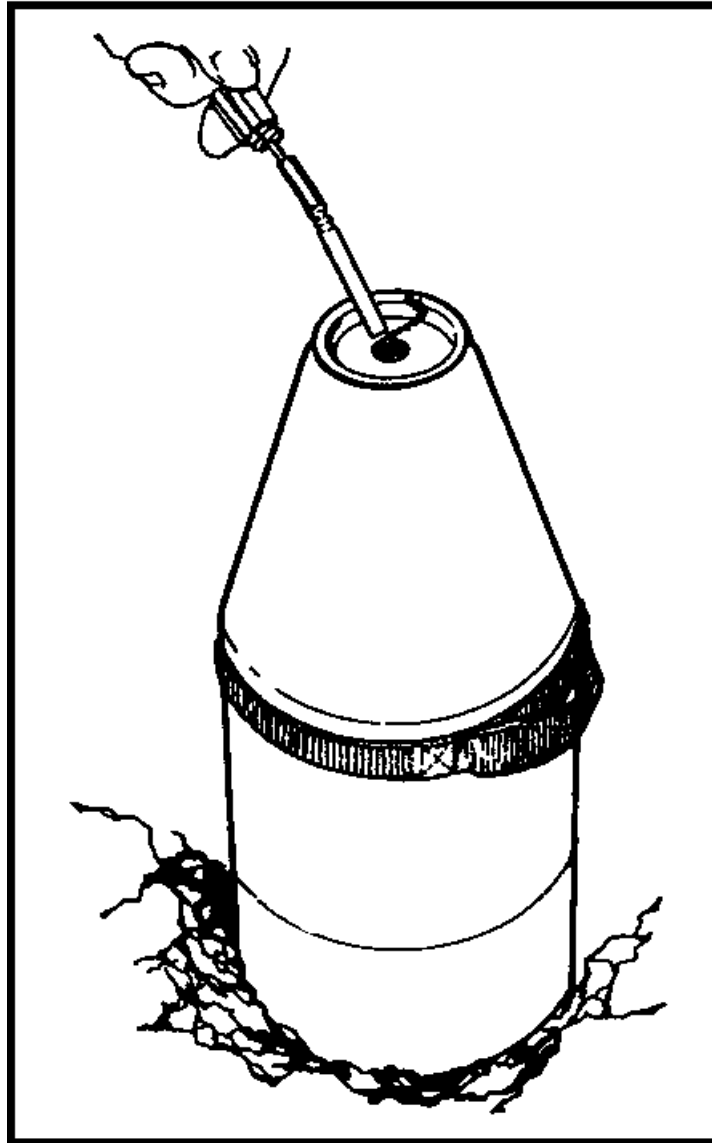

Figure 051-193-1311-19  
Priming the shaped charger with MDI

12. Prime the bangalore torpedo with a MDI high-strength blasting cap and a M1A4 priming adapter.  
NOTE: Do not prime the charge until it is placed on the target.

NOTE: Secure the blasting cap in the threaded cap well by using tape when a priming adapter is not used.

- a. Place the blasting cap underneath a sandbag.
- b. Position the charge.
- c. Cut the desired amount of shock tube or cut the sealed end of the shock tube and remove the J-hook when attached.
- d. Slide the priming adapter onto the shock tube, threaded end first, down to the blasting cap.
- e. Remove the blasting cap from underneath the sandbag. Slide the priming adapter over the blasting cap and place the blasting cap back underneath the sandbag.

**Performance Steps**

- f. Replace the J-hook when used.
- g. Remove the blasting cap from underneath the sandbag.
- h. Secure the blasting cap in one hand. Ensure that the cap is completely enclosed in the hand, facing down, and away from the thumb.
- i. Insert the blasting cap into the threaded cap well of the bangalore torpedo. Secure the blasting cap by tightening the priming adapter into the threaded cap well (Figure 051-193-1311-20).

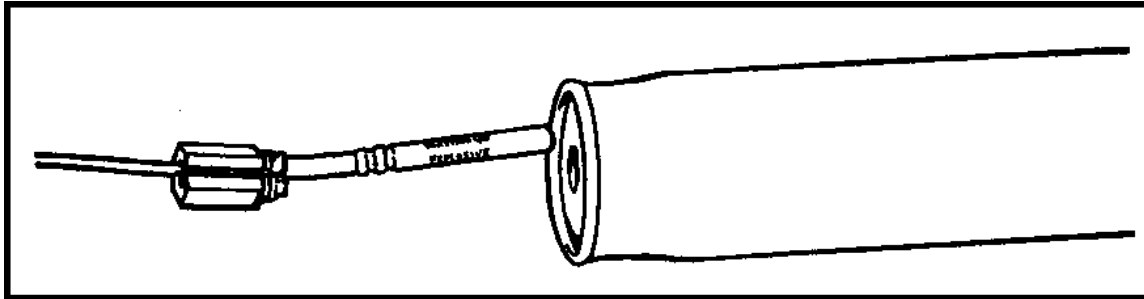

Figure 051-193-1311-20  
Priming bangalore with MDI

**Evaluation Preparation:** Setup: Provide the soldier with the items listed in the conditions statement. Ensure that the soldier has various types of military explosives to be primed, using detonating cord and a MDI. Use the inert demolition equipment for this task. Brief soldier: Tell the soldier he will be priming several different types of military explosives using detonating cord and MDI.

**Performance Measures**

- 1. Primed military explosives with detonating cord.
- 2. Primed military explosives with MDI.

**Results**

P F  
P F

**Evaluation Guidance:** Score the soldier GO if all steps are passed (P). Score the soldier NO-GO if any step is failed (F). If the soldier fails any step, show him how to do it correctly.

**References**

**Required**

**Related**

FM 5-250  
TM 9-1375-213-12



## CONSTRUCT DEMOLITION INITIATING SETS

### 051-193-1312

**Conditions:** As a combat engineer squad member in a field environment, given a demolition firing system, an M11 or an M16 branch line, an M12 or an M13 transmission line, an M14 time-delay fuze, an M81 fuze igniter, an M9 holder, adhesive tape, a demolition knife, and a sandbag.

**Standards:** Constructed a command and delay demolition initiating set without causing premature detonation.

#### **Performance Steps**

NOTE 1: All modernized demolition initiator (MDI) blasting caps can be used to initiate a shock tube. Only use the M11, M14, and M15 high-strength blasting caps to detonate the detonation cord line main or ring main.

NOTE 2: Use MDI initiating sets to initiate instantly by using M12 and M13 transmission lines or an M14 delay fuze for delay initiation up to 5 minutes.

NOTE 3: When using combination command and delay initiation sets on demolition firing systems, the command initiation set will be the primary set and the delay will be the secondary initiating set. Place a sandbag on the secondary initiation set's blasting cap to reduce fragmentation hazard of the cap when detonated from the firing system.

1. Construct a command initiation set.
  - a. Lay out one or more M12s or M13s to achieve the necessary safe distance from the explosive charges being emplaced, and place the plastic connectors under a sandbag.
  - b. Connect the blasting cap furthest from the initiation point to the demolition firing system.
    - (1) MDI-demolition firing system. Remove the plastic connector from underneath the sandbag. Open the large-hinged flap on the plastic connector of the M12 or M13 transmission line and loop the end of the firing system shock tube into a 6-inch bite around the plastic connector. Insert the shock tube into the channels of the plastic connector. Snap the large-hinged flap shut and secure it with tape (Figure 051-193-1312-1).

**Performance Steps**

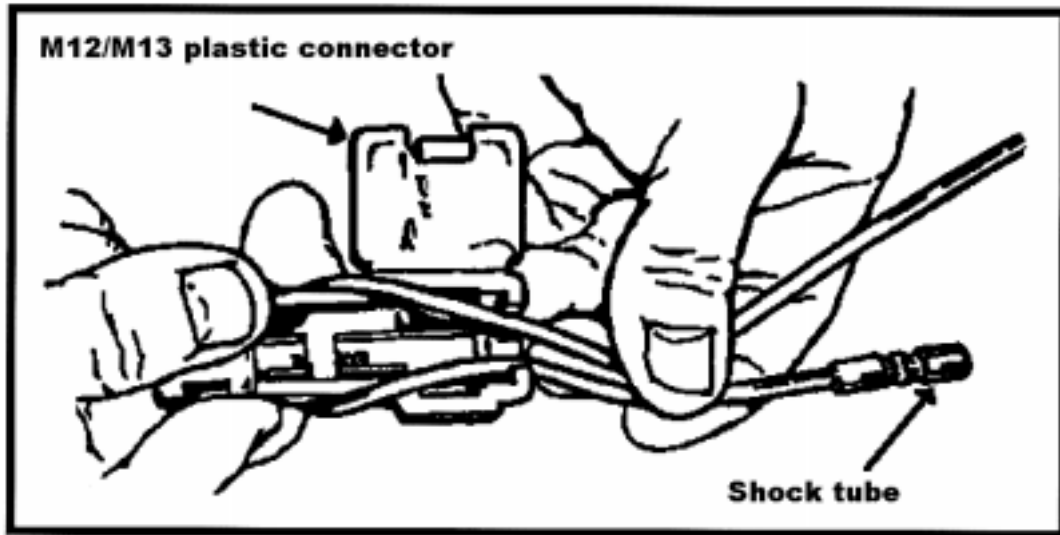

Figure 051-193-1312-1  
Connecting the shock tube to the M12/M13

NOTE 1: Continue this procedure with the M12s and M13s to the initiation point or until the necessary safe distance from the explosives is achieved.

NOTE 2: Ensure that the shock tube is in contact with the blasting cap.

NOTE 3: Do not insert more than five shock tubes into the plastic connector.

(2) Detonating-cord demolition firing system.

(a) Lay out one or more M12s or M13s to achieve the necessary safe distance from the explosive charges being emplaced and place the plastic connectors under a sandbag. An M11 high-strength blasting cap will be connected to the detonating-cord ring main or line main (Figure 051-193-1312-2).

## Performance Steps

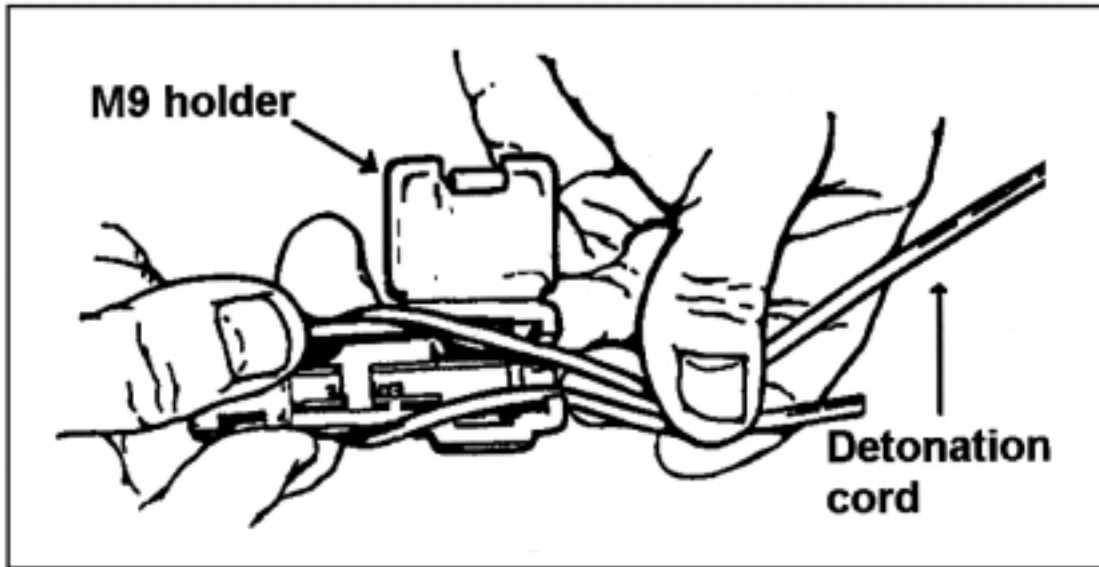

Figure 051-193-1312-2  
Connect detonating cord to the M9 holder

- (b) Connect the blasting cap furthest from the initiation point to the demolition firing system.
- (c) Open both hinged flaps on the M9 holder and insert the M11 blasting cap into the cap slot and snap the flap shut. Loop the detonating-cord firing system ring main or line main into a 6-inch bite around the M9 holder and insert the detonation cord into the channels of the holder. Snap the hinged flap shut and secure it with tape.

NOTE: Ensure that the detonating cord is in contact with the blasting cap.

- (d) Remove the plastic connector from underneath the sandbag. Open the large hinged flap on the plastic connector of the M12 or M13 transmission line and loop the end of the M11 shock tube into a 6-inch bite around the plastic connector. Insert the shock tube into the channels of the plastic connector. Snap the large hinged flap shut and secure it with tape (refer to Figure 051-193-1312-1).

NOTE 1: Ensure that the shock tube is in contact with the blasting cap.

NOTE 2: Continue this procedure with the M12s and M13s to the initiation point or until the necessary safe distance from the explosives is achieved.

- c. Connect the M81 fuze igniter to the shock tube.
  - (1) Turn the M81 end cap a half turn counterclockwise and pull the shipping plug out of the igniter (Figure 051-193-1312-3).

**Performance Steps**

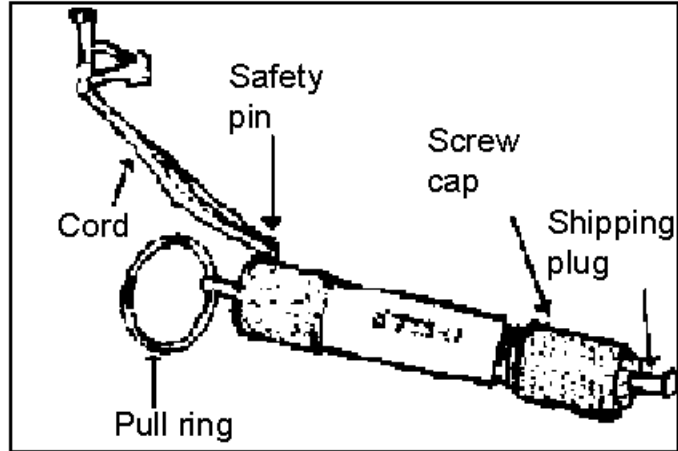

Figure 051-193-1312-3  
M81 fuze igniter

(2) Cut off the crimped, sealed end of the shock tube.

NOTE: Use the demolition knife to cut the shock tube for a smooth cut. M2 crimpers do not ensure a smooth cut.

(3) Push the shock tube into the M81's end cap as far as it will go (Figure 051-193-1312-4).

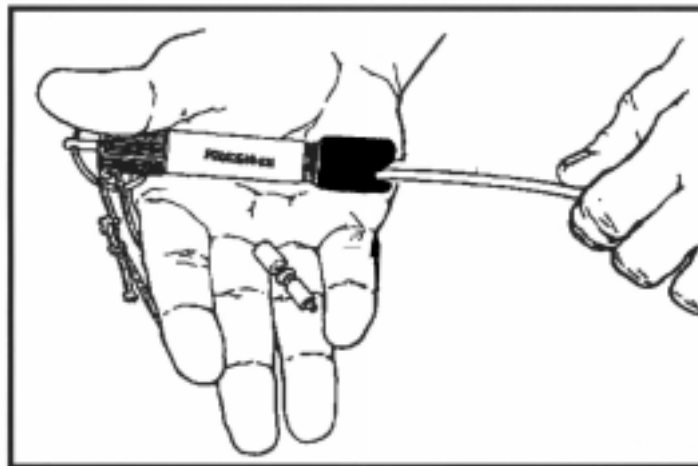

Figure 051-193-1312-4  
M81 and shock tube

(4) Turn the igniter's end cap clockwise, once the shock tube is seated. Finger tighten to secure the shock tube into the igniter.

(5) Hold the igniter securely and pull lightly on the tube to ensure that it is secure.

d. Actuate the M81 fuze igniter to initiate the system upon command from the officer in charge (OIC)/noncommissioned officer in charge (NCOIC).

(1) Squeeze together the spread legs of the safety cotter pin.

(2) Use the safety pin's cord to remove the safety cotter pin from the igniter's body.

(3) Actuate the igniter by sharply pulling its pull ring. The pop of the igniter's primer should be heard.

**Performance Steps**

NOTE: If the primer does not fire the M81, it can be recocked and reactivated by holding the igniter firmly and pushing the pull rod back into the igniter until a click is heard or felt, and again, sharply pulling the pull ring to actuate it.

2. Construct a delay initiation set.

NOTE: The M14 delay will allow up to a 5-minute delay before detonation. Each yellow band indicates a 1-minute delay.

- a. MDI-demolition firing system. Open both of the hinged flaps on the M9 holder and insert the M14 blasting cap into the cap slot and snap the flap shut. Loop the firing system shock tube into a 6-inch bite around the M9 holder and insert the shock tube into the channels of the holder. Snap the hinged flap shut and secure it with tape (refer to Figure 051-193-1312-1).
- b. Detonating-cord demolition firing system. Open both hinged flaps on the M9 holder and insert the M14 blasting cap into the cap slot and snap the flap shut. Loop the firing-system detonating cord into a 6-inch bite around the M9 holder and insert the detonating cord into the channels of the holder. Snap the hinged flap shut and secure it with tape (refer to Figure 051-193-1312-2).
- c. Connect the M81 fuze igniter to the shock tube.
  - (1) Turn the M81 end cap a half turn counterclockwise and pull the shipping plug out of the igniter (refer to Figure 051-193-1312-3).
  - (2) Cut off the crimped, sealed end of the M14 delay blasting cap tube.
  - (3) Push the tube into the M81's end cap as far as it will go (refer to Figure 051-193-1312-4).
  - (4) Turn the igniter's end cap clockwise. Once the shock tube is seated, finger tighten to secure the shock tube into the igniter.
  - (5) Hold the igniter securely and pull lightly on the tube to ensure that it is secure.
- d. Initiate the system upon command from the OIC/NCOIC and actuate the M81 fuze igniter.
  - (1) Squeeze together the spread legs of the safety cotter pin.
  - (2) Use the safety pin's cord to remove the safety cotter pin from the igniter's body.
  - (3) Actuate the igniter by sharply pulling its pull ring. The pop of the igniter's primer should be heard.

NOTE: If the primer does not fire the M81, it can be recocked and reactivated by holding the igniter firmly and pushing the pull rod back into the igniter until a click is heard or felt and again sharply pulling the pull ring to actuate it.

**Evaluation Preparation:** Setup: Provide the soldier with the items listed in the conditions. Brief soldier: Tell the soldier to construct a demolition initiation set using command initiation and delay initiation.

<b>Performance Measures</b>	<b>Results</b>	
1. Constructed a command initiation set.	P	F
2. Constructed a delay initiation set.	P	F

**Evaluation Guidance:** Score the soldier GO if all steps are passed (P). Score the soldier NO-GO if any step is failed (F). If the soldier fails any step, show him how to do it correctly.

**References**  
Required

**Related**  
FM 5-250

**IDENTIFY CHARACTERISTICS OF MILITARY DEMOLITIONS AND EXPLOSIVES**  
**051-193-1313**

**Conditions:** As a combat engineer squad member in a field environment, given various types of military demolitions and explosives.

**Standards:** Identified the characteristics of military demolitions and explosives correctly.

**Performance Steps**

NOTE: The soldier must be familiar with the evaluated material before evaluation.

**Evaluation Preparation:** Setup: For the classroom, present the figures in this task or similar material (mockups, graphic training aids (GTAs), flash cards, overhead transparencies, 35 millimeter slides) to the soldier. For a field environment, present the figures in this task as emplaced mockups, training devices, or actual items. Brief soldier: Tell the soldier that pictures or similar material will be shown for 30 seconds each. During each 30-second period, the soldier must identify the characteristics of each item correctly.

<b>Performance Measures</b>	<b>Results</b>	
1. Identified the characteristics of military demolitions.	P	F
2. Identified the characteristics of military explosives.	P	F

**Evaluation Guidance:** Score the soldier GO if all steps are passed (P). Score the soldier NO-GO if any step is failed (F). If the soldier fails any step, show him how to do it correctly.

**References**

**Required**

**Related**

FM 5-250

## Subject Area 3: Basic Combat Construction

**INSTALL WIRE OBSTACLE MATERIALS****051-195-1020**

**Conditions:** As a combat engineer squad member in a field environment, given U-shaped pickets, barbed wire, concertina, wire gauntlets, wooden sticks, a picket driving cap, a sledgehammer or a picket pounder, ground staples, and a suitable working area with the expected direction of enemy travel.

**Standards:** Inserted U-shaped pickets, ensuring that the concave side was facing the enemy and the lower notch was about 4 inches (10 centimeters) off the ground. Made correct barbed wire and apron ties and tightened loose wire by racking and laying out and installing concertina.

**Performance Steps**

1. Install an U-shaped picket to support the fencing material.
  - a. Install the U-shaped picket with a driving cap and a sledgehammer.
    - (1) Lay the picket on the ground with the narrow end pointing toward the enemy and the concave side facing skyward.
    - (2) Place a picket-driving cap over the top of the picket.

NOTE: The top of the picket is the wide end that faces away from the enemy.

- (3) Stand the picket on the narrow end and pound on the driving cap with a sledgehammer until the lower notch of the picket is about 4 inches (10 centimeters) off the ground.

NOTE: The concave side of the picket must face the enemy.

- b. Install the U-shaped picket with a picket pounder.
    - (1) Lay the picket on the ground so the narrow end is pointing toward the enemy and the concave side is facing skyward.
    - (2) Place a picket pounder over the top of the picket.

NOTE: Many engineer units make their own picket pounders. The picket pounder is easier for one-man picket installation than the driving cap and sledgehammer.

- (3) Stand the picket on the narrow end and raise and lower the picket pounder. Drive the picket into the ground until the lower notch of the picket is about 4 inches (10 centimeters) off the ground.

NOTE: The concave side of the picket must face the enemy.

2. Make barbed wire posts and apron ties and tighten loose wire by racking.

**WARNING: USE WIRE GAUNTLETS WHEN WORKING WITH BARBED WIRE TO AVOID HAND INJURY.**

- a. Make barbed-wire post ties (Figure 051-195-1020-1).

Performance Steps

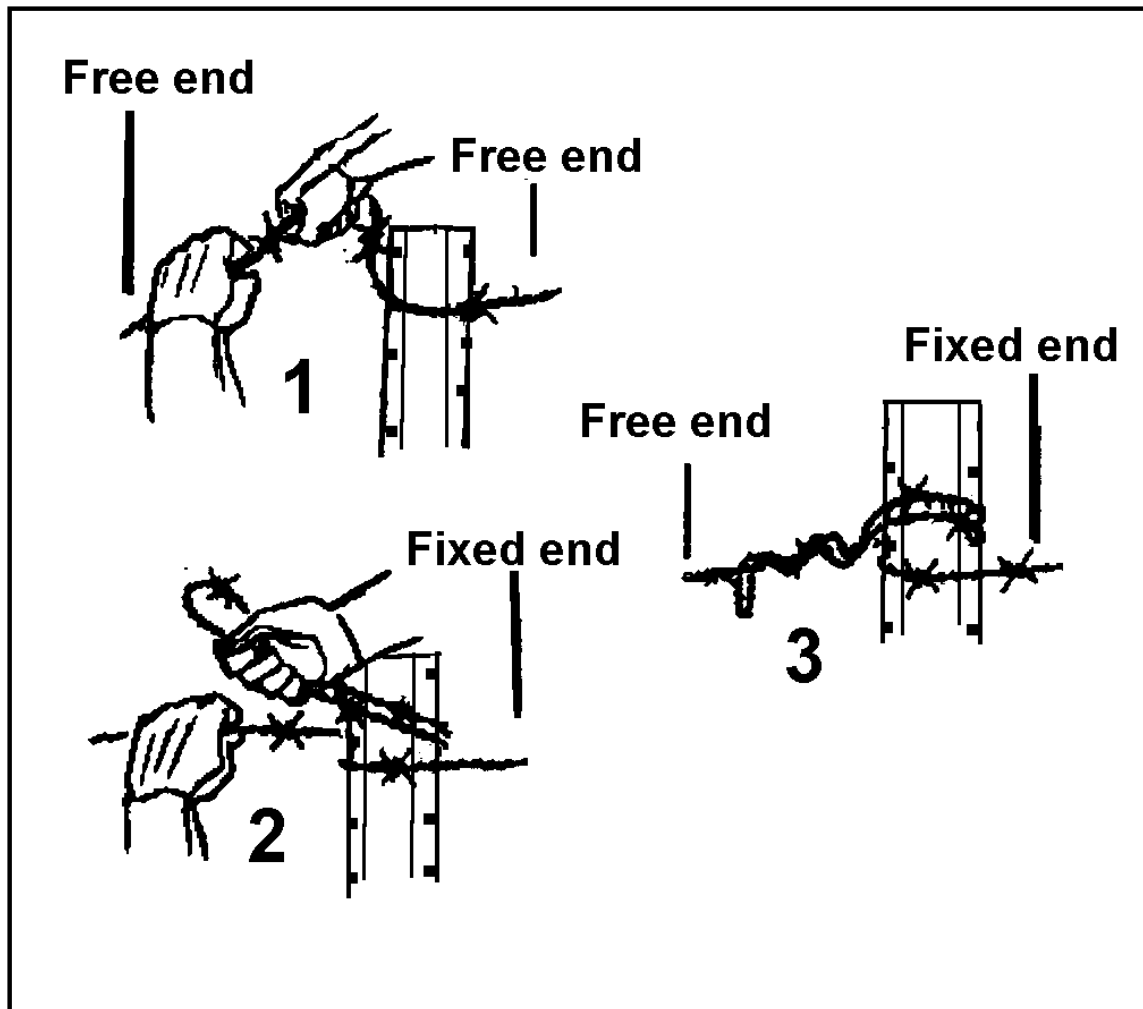

Figure 051-195-1020-1  
Post tie

NOTE: Use the post tie to fasten standard barbed wire to wooden posts or to U-shaped pickets.

- (1) With your palm down, reach around the picket, over the fixed end, and take a loop from the free end.
  - (2) Wrap the loop around the post above the fixed end.
  - (3) Wrap the loop around the free end at least two turns to complete the tie.
- b. Make barbed wire apron ties (Figure 051-195-1020-2).



Performance Steps

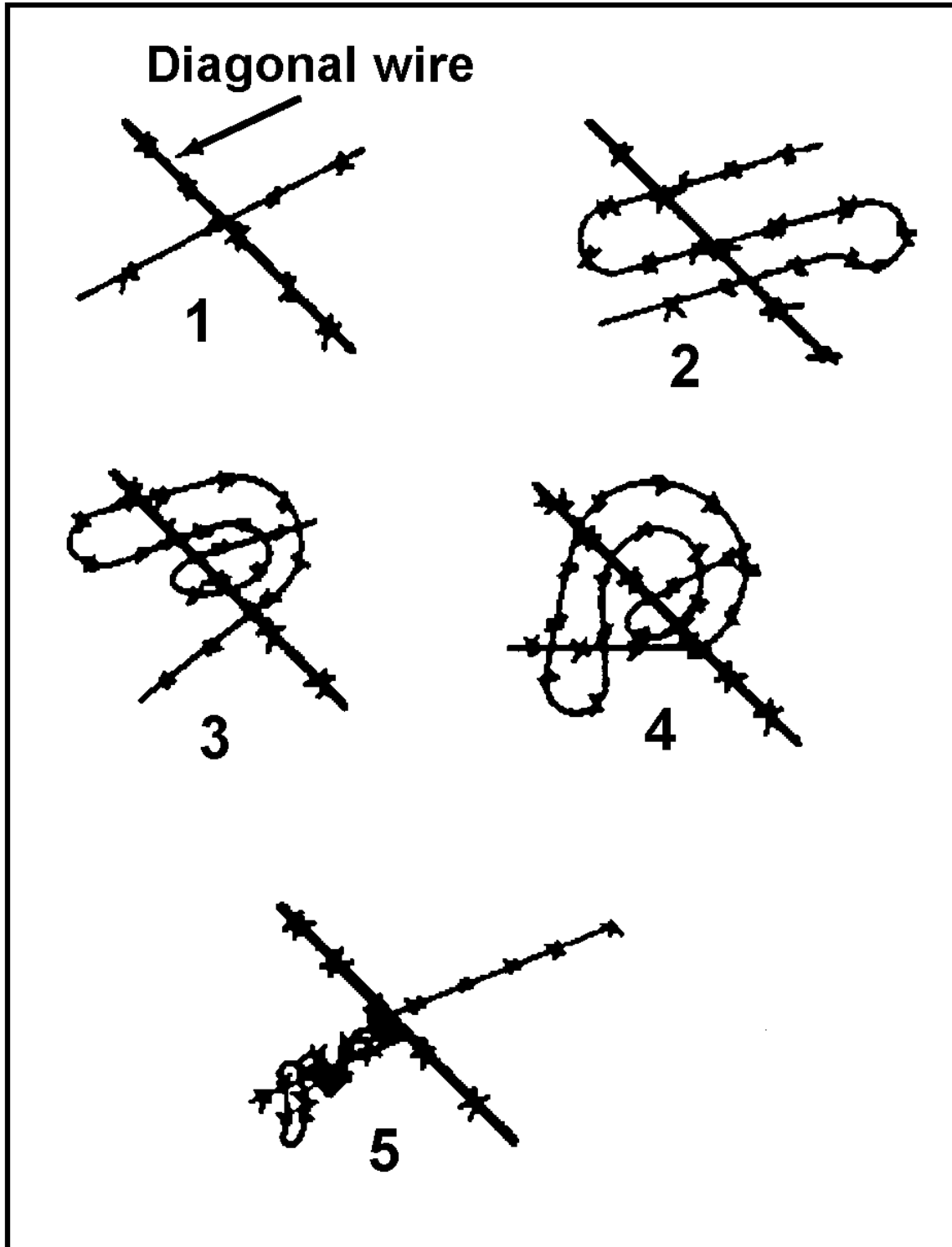

Figure 051-195-1020-2  
Apron tie

NOTE: Use the apron tie whenever two wires that cross must be tied together.

**Performance Steps**

- (1) Draw a large loop from the free end back under the wire.
  - (2) Bring the loop up and over the top of the diagonal wire.
  - (3) Bring the loop down and under the free end.
  - (4) Wind the loop around the free end at least two complete turns.
- c. Tighten loose wires by racking with a short stick. Rack the wire in the middle, not at the ties or where wires intersect (Figure 051-195-1020-3).

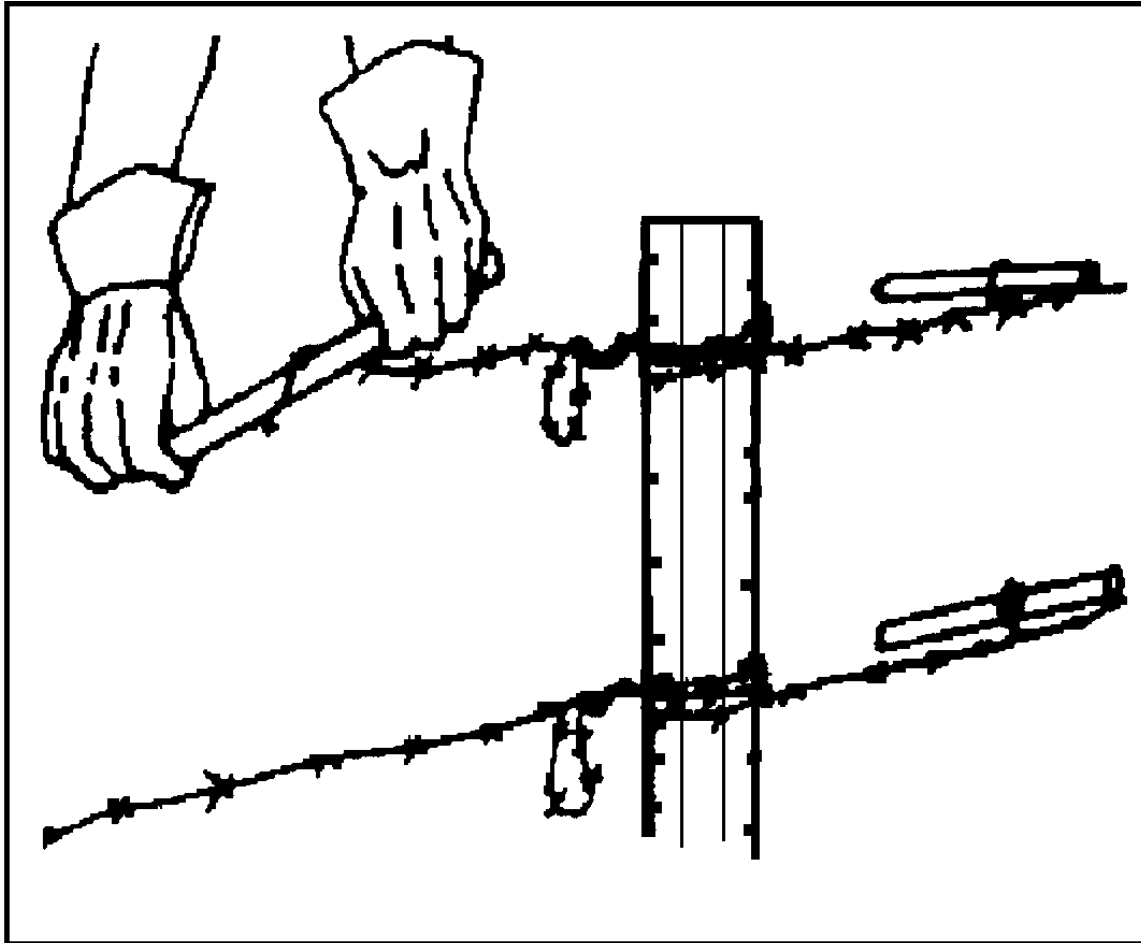

Figure 051-195-1020-3  
Tighten loose wire by racking

3. Install and collapse concertina wire.

NOTE: Use wire gauntlets when working with concertina to avoid hand injury.

a. Lay out concertina.

NOTE: When carrying a roll of concertina, step inside the roll, grasp the carrying handles, lift the roll about waist high, and carry it to the required location.

- (1) Untie the plain-wire bindings from around the quarter points of the coil. Leave the plain-wire bindings attached to one-end hoop.

NOTE: Concertina should never be extended longer than 15 meters (49.2 feet) and should not be used across openings less than 5 meters (16.4 feet). Normally, a minimum of two soldiers will extend concertina, although one soldier can extend concertina as described in this task.

**Performance Steps**

- (2) Grasp the top end-hoop carrying handles with the loose coil laid flat on the ground, then lift the end hoop upward. Extend the concertina by bouncing the extended coil in a line parallel to the desired fence line until about half of the coil is extended.

NOTE: During the extending procedure, do not overextend short portions of the extending coil. When snags and uneven hoops occur, stop and loosen the snags and hoops to ensure that the concertina opens and extends evenly without distorting its shape.

- (3) Extend the remaining half of the coil by first lifting the bottom end-hoop carrying handles. Grasp both carrying handles and extend the second half by bouncing the coil in the same manner as the first half of the coil.

b. Install concertina.

NOTE: Personnel will remain on the friendly side of the fence at all times.

- (1) Place the end hoop over the end picket.
  - (a) Grasp the side of the coil and end hoop while facing the extended concertina from the friendly side.
  - (b) Lift and place the lower and upper midpoints of the first coil over the end picket.

NOTE: The middle coils of concertina are simply lifted and placed over the individual pickets along the fence line.

- (2) Connect concertina when joining concertinas over a picket (Figure 051-195-1020-4).

**Performance Steps**

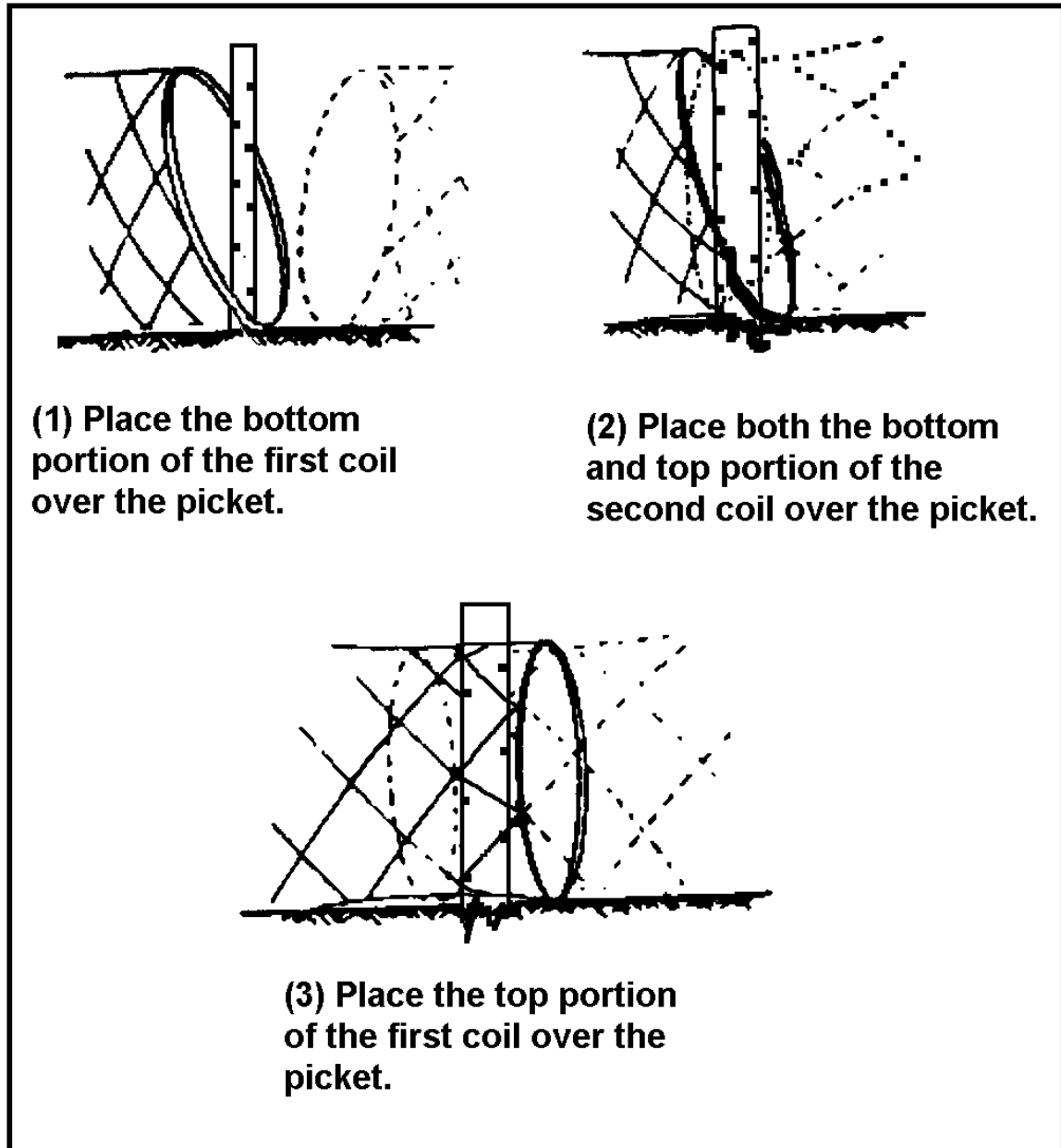

Figure 051-195-1020-4  
Joining concertinas

- (a) Grasp the side of the coil and end hoop while facing the extended concertina from the friendly side.
- (b) Lift and place the lower midpoint of the first coil over the picket.
- (c) Place the second concertina's first coil over the picket in the same manner as over an end picket.
- (d) Lift the upper midpoint of the first coil on the first concertina over the picket while pushing downward on the second concertina's first coil.
- (3) Connect concertina when joining concertinas without a picket.
  - (a) Insert the first coil of one concertina inside the first coil of the second concertina.

**Performance Steps**

- (b) Use plain steel wire (binding wire) to tie the two concertinas together.
- c. Install ground staples.
  - (1) Hammer ground staples into the ground. Keep the hoop wire between the staple legs.
  - (2) Install a ground staple over each pair of end hoops at the bottom of the coil and at the quarter points between the pickets.

NOTE: The enemy row concertinas are always stapled to the ground.

- d. Install horizontal wire.
  - (1) Stretch a strand of barbed wire along the top of the extended concertina.
  - (2) Use a post tie to tie the barbed wire to each picket (Figure 051-195-1020-5).

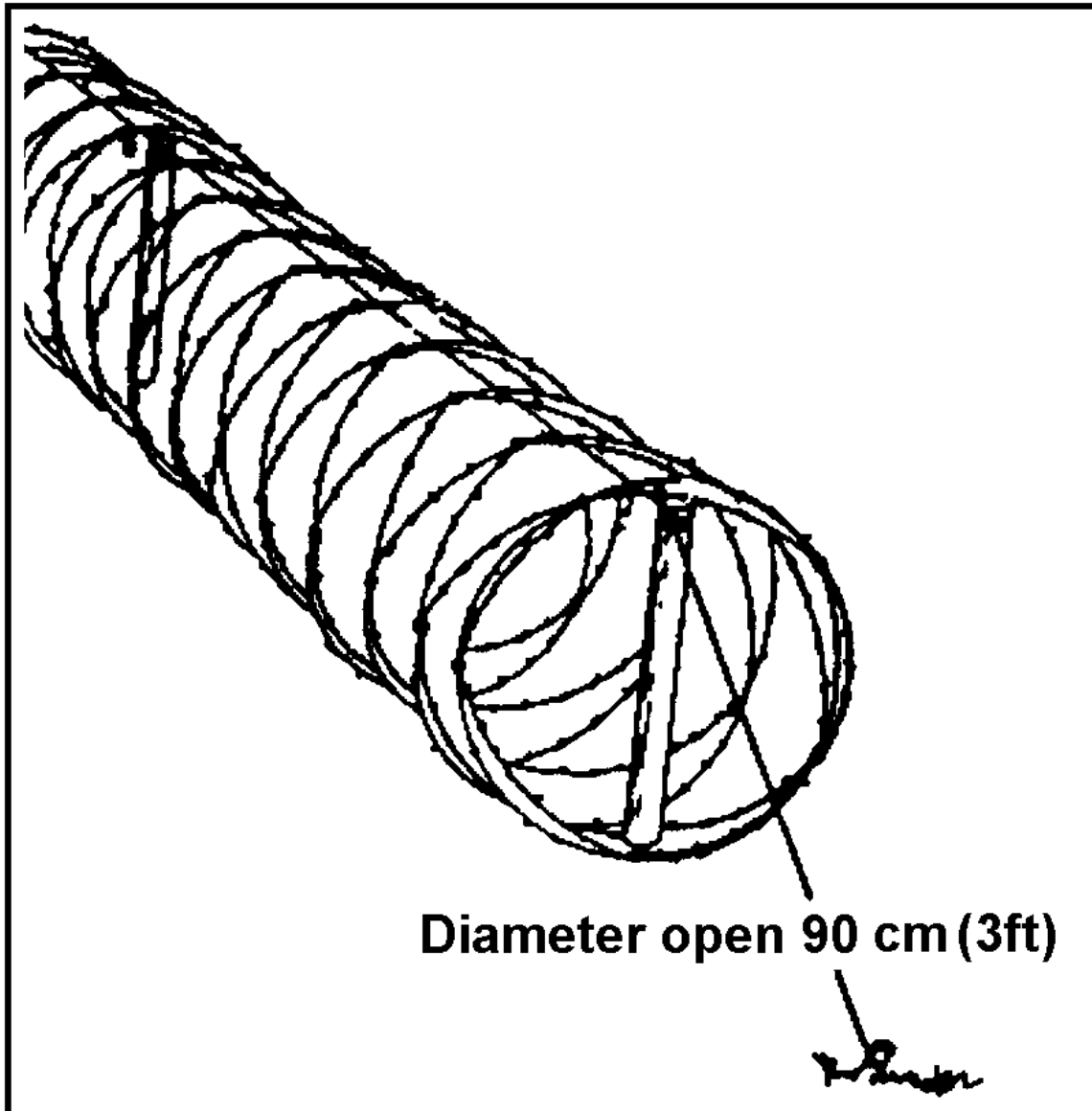

Figure 051-195-1020-5  
Anchored concertina

NOTE: The horizontal wire should be as tight as possible to improve the resistance of the fence against crushing. Racking may be required.

- (3) Stagger the end hoops and the joints of multirow fences.

**Performance Steps**

- ( a ) Stagger the rows of double-concertina fences every 2.5 paces (1.9 meters).
- ( b ) Stagger the top row of triple-concertina fences between the lower two rows of concertina.
- (4) Install and rack a top-row concertina.
  - ( a ) Extend and join concertina as required for the top row.
  - ( b ) Lift the concertina from the friendly side and place the coils in the trough formed by the bottom rows.
  - ( c ) Rack the top-row concertina to the rear horizontal wire at points halfway between the rear-row long pickets.
  - ( d ) If the noncommissioned officer in charge (NCOIC) authorizes access to the enemy side of the fence, similarly rack the top-row concertina to the forward horizontal wire.

NOTE: The end hoops at each end of the top row are racked to the rear horizontal wire between the anchor picket and the end-long picket.

e. Collapse concertinas.

NOTE: Normally, a minimum of two soldiers will collapse concertinas, although one soldier can collapse concertinas as described in this task.

- (1) Remove the horizontal wire from the concertina.
- (2) Remove kinks in the coils, tighten loose clips, or replace missing clips with plain binding wire.
- (3) Place a foot at the bottom of one end of the hoop and grasp the top carrying handle.
- (4) Walk toward the other end hoop while feeding the wire into your hand and against your foot.
- (5) Lay the loose coil flat on the ground, when closed, and compress it with your feet.
- (6) Remove the plain-wire bindings from the handles and tie the coil at quarter points.

**Evaluation Preparation:** NOTE: This task may be used to evaluate more than one soldier at one time on the the overall installation of a barbed-wire fence or a concertina-wire obstacle. Setup: Provide the soldier(s) with the items listed in the conditions. Brief soldier: Ensure that the soldier(s) know the evaluation standard before beginning the task.

**Performance Measures**

**Results**

1. Installed the picket with a driving cap and sledgehammer.	P	F
2. Installed the picket with a picket pounder.	P	F
3. Made barbed-wire post ties.	P	F
4. Made barbed-wire apron ties.	P	F
5. Tightened loose wire by racking.	P	F
6. Laid out concertina.	P	F
7. Installed concertina.	P	F
8. Installed ground staples.	P	F
9. Installed horizontal wire.	P	F
10. Collapsed concertina.	P	F

**Evaluation Guidance:** Score the soldier GO if all steps are passed (P). Score the soldier NO-GO if any step is failed (F). If the soldier fails any step, show him how to do it correctly.

**References  
Required**

**Related**  
FM 5-102  
FM 5-34

Subject Area 4: Basic Rigging

**TIE KNOTS**  
**051-200-1075**

**Conditions:** As a combat engineer in a field environment, given lengths of fiber rope up to 1 inch in diameter (including at least one rope of a different diameter) and wooden poles of various sizes.

**Standards:** Tied each knot so it performed the designed function without failure.

**Performance Steps**

1. Tie a square knot. Use the square knot to tie together two dry ropes of the same thickness. Make the first crossing left over right or right over left. Tie the second crossing opposite the first (Figure 051-200-1075-1).

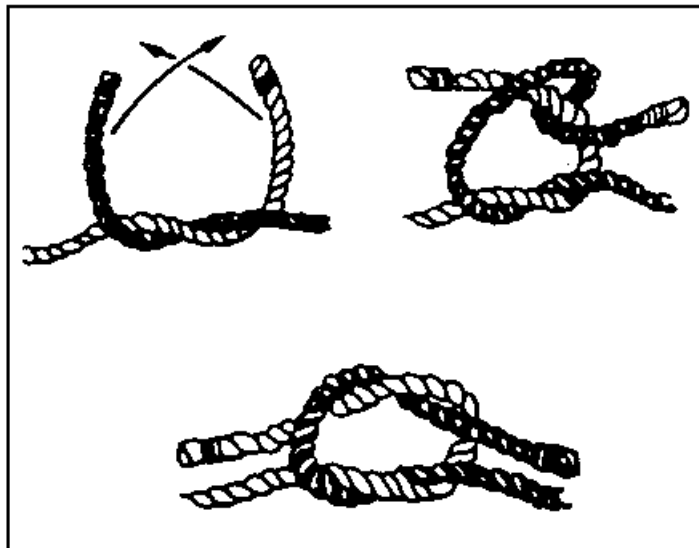

Figure 051-200-1075-1  
Tying a square knot

2. Tie a bowline. Use the bowline for forming a nonslipping loop (Figure 051-200-1075-2).



**Performance Steps**

Figure 051-200-1075-2  
Tying a bowline

3. Tie a clove hitch. Use the clove hitch to fasten a rope to a timber, pipe, or post. The clove hitch is also used for making other knots (Figure 051-200-1075-3).

Performance Steps

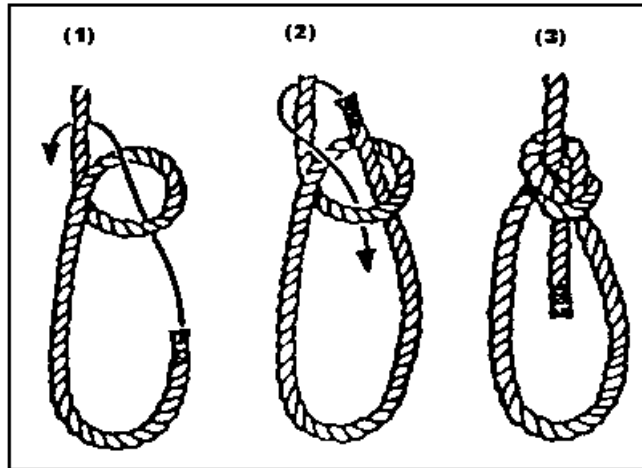
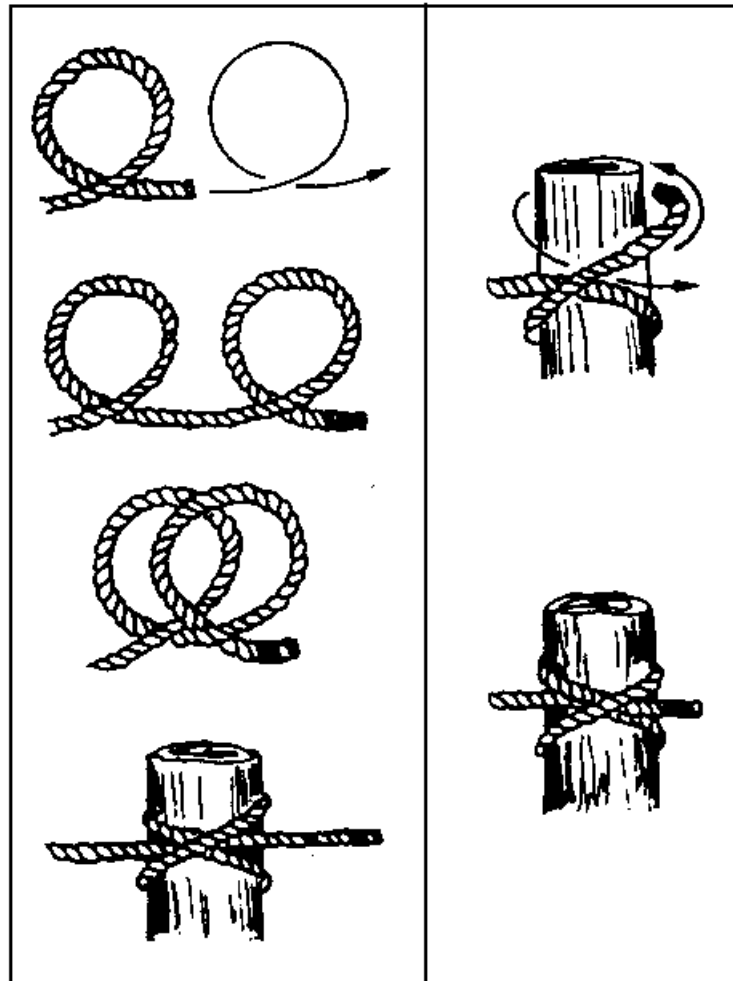

Figure 051-200-1075-3  
Tying a clove hitch

4. Tie a girth hitch. Use a girth hitch on rope bridges (Figure 051-200-1075-4).

**Performance Steps**

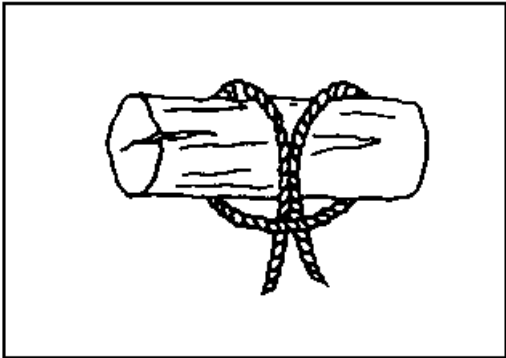

Figure 051-200-1075-4  
Tying a girth hitch

**Evaluation Preparation:** Setup: Provide the soldier with the items listed in the conditions. Brief soldier: Tell the soldier what is expected.

<b>Performance Measures</b>	<b>Results</b>	
1. Tied a square knot.	P	F
2. Tied a bowline.	P	F
3. Tied a clove hitch.	P	F
4. Tied a girth hitch.	P	F

**Evaluation Guidance:** Score the soldier GO if all steps are passed (P). Score the soldier NO-GO if any step is failed (F). If the soldier fails any step, show him how to do it correctly.

**References**  
**Required**

**Related**  
FM 5-125

Subject Area 5: Construction Drawing

**INTERPRET CONSTRUCTION DRAWINGS AND PRINTS**

**051-236-1202**

**Conditions:** As a carpentry and masonry specialist in a field environment on a construction site, given construction prints, a pencil, paper, and Technical Manual (TM) 5-704.

**Standards:** Interpreted lines and identified the title block information, general notes, specifications, and detailed drawings of construction prints according to TM 5-704.

**Performance Steps**

1. Identify and interpret the following three construction drawing classifications:
  - a. Original. An original drawing is the manual or computerized drawing produced by the draftsman.
  - b. Intermediate. An intermediate is a copy of the original that is used to make prints. An intermediate is used--
    - (1) To avoid the risk of damaging the original.
    - (2) Because the original is not suitable for the type of reproduction process used for making prints.
  - c. Print. Is the drawing copy made from the intermediate or sometimes from the original. A print is the working copy of the drawing that is used on the job.
  - d. Refer to TM 5-704 for line identification and interpretation. Figure 051-236-1202-1 shows the line conventions.

Performance Steps









LINE CONVENTIONS			
NAME	CONVENTION	DESCRIPTION AND APPLICATION	EXAMPLE
VISIBLE LINES		HEAVY UNBROKEN LINES  USED TO INDICATE VISIBLE EDGES OF AN OBJECT	
HIDDEN LINES		MEDIUM LINES WITH SHORT EVENLY SPACED DASHES  USED TO INDICATE CONCEALED EDGES	
CENTER LINES		THIN LINES MADE UP OF LONG AND SHORT DASHES ALTERNATELY SPACED AND CONSISTENT IN LENGTH  USED TO INDICATE SYMMETRY ABOUT AN AXIS AND LOCATION OF CENTERS	
DIMENSION LINES		THIN LINES TERMINATED WITH ARROWHEADS AT EACH END  USED TO INDICATE DISTANCE MEASURED	
EXTENSION LINES		THIN UNBROKEN LINES  USED TO INDICATE EXTENT OF DIMENSIONS	

Figure 051-236-1201-1  
Line conventions

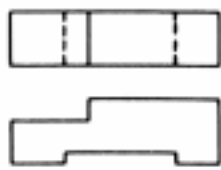
- e. Refer to TM 5-704, Appendix B, for identification and interpretation of electrical and plumbing and symbols. Refer to TM 5-704 for identification and interpretation of construction materials symbols.

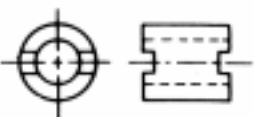
**Performance Steps**

- Identify and interpret the title block of construction prints (Figure 051-236-1202-2). The title block is found in the lower right corner of the construction prints. The title block consist of six parts, they are--

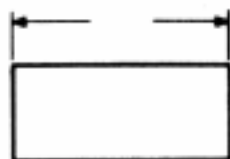
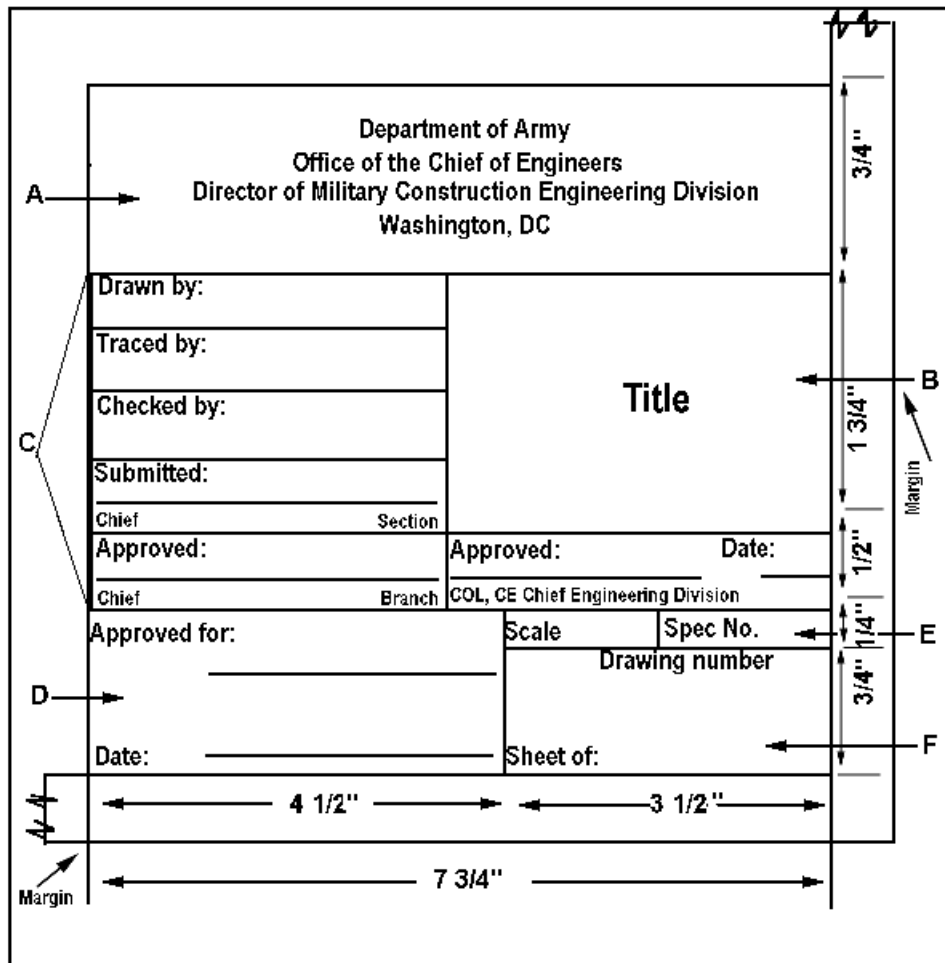

Figure 051-236-1202-2  
Typical title block

- Part A - The name and address of the preparing agency.
- Part B - The title of the drawing.
- Part C - The drafting record.
- Part D - Authentication and date approved.
- Part E - The scale and specification number.
- Part F - The drawing number and sheet number of multiple sheet drawings.

NOTE: TM 5-704 shows an example of a title block.

- Identify general notes and specifications (Table 051-236-1202-1).

**Performance Steps**

Schedule of Drawings		
DWG. No.	Description	Sheet No.
72-32	Plans	1 of 1
72-31	Special details	2 of 3
72-98	Standard details	1 - 8
34-91	STD frame barracks type building panel schedule	1 of 2
72-99	Bill of materials	3 of 4

Table 051-236-1202-1  
Schedule of drawings

NOTE 1: The general notes and specifications are found in the center bottom portion of the construction prints. For multiple sheet drawings, the general notes and specifications will be annotated on the first sheet of the drawings.

NOTE 2: The general notes and specifications explain construction methods or specific materials not indicated on the drawings themselves. These notes may list allowable substitutions, special provisions for certain locations, and additional references.

4. Identify detailed drawings.

NOTE: Detailed drawings are large-scale drawings which show features that do not appear or appear too small on construction prints. Detailed drawings are noted by a code or symbol on the construction prints. The code or symbol will be a circle with a number or a letter and number within it.

- a. Identify the detailed drawing symbols by turning to the detailed drawing section of the construction prints.
- b. Find the drawing that corresponds with the symbol from the construction prints. This drawing will show the specific details about the section of the construction prints. The detailed drawings are normally found in the last few sheets of the construction prints.

**Evaluation Preparation:** Setup: Provide the soldier with the items listed in the conditions. Brief soldier: Tell the soldier to interpret lines and symbols, and identify title block information, general notes, specifications, and detailed drawings of construction prints according to TM 5-704.

**Performance Measures**

**Results**

- |   |   |   |
|---|---|---|
| 1. Identified and interpreted the three construction drawing classifications.             | P | F |
| 2. Identified and interpreted information in the title block according to TM 5-704.       | P | F |
| 3. Identified and interpreted the general notes and specifications according to TM 5-704. | P | F |
| 4. Identified detailed drawings.  | P | F |

**Evaluation Guidance:** Score the soldier GO if all steps are passed (P). Score the soldier NO-GO if any step is failed (F). If the soldier fails any step, show him how to do it correctly.

STP 5-51B12-SM-TG

**References**

**Required**

STP 5-51H34-SM-TG

TM 5-704

**Related**



## Subject Area 6: Construction Planning and Materials

**IDENTIFY BUILDING MATERIALS****051-236-1184**

**Conditions:** As a carpentry and masonry specialist in a training environment, given Field Manual (FM) 5-426, lumber, plywood, nails, screws, and bolts.

**Standards:** Identified building materials by answering written questions pertaining to lumber, plywood, and common hardware according to FM 5-426.

**Performance Steps**

NOTE: Refer to FM 5-426.

1. Identify building materials. Building materials include--
  - a. Lumber. Wood that has been cut to size.
    - (1) Lumber grade. Select lumber that is of good appearance and finishing. Lumber is identified by the following grade names for comparison of quality:
      - (a) Grade A is suitable for natural finishes and is practically clear.
      - (b) Grade B is suitable for natural finishes, is of high quality, and is generally clear.
      - (c) Grade C is suitable for high-quality paint finishes.
      - (d) Grade D is suitable for paint finishes between high-finishing grades and common grades and has somewhat the nature of both.
    - (2) Common lumber.
      - (a) Number 1 common is suitable for use without waste, it is sound and tight knotted, and it may be considered watertight lumber.
      - (b) Number 2 common is less restricted in quality than Number 1, but of the same general quality. It is used for framing, sheathing, and other structural forms where the stress or strain is not too great.
      - (c) Number 3 common permits some waste, and it is lower in quality than Number 2. It is used for such rough work as footing, guardrails, and rough flooring.
      - (d) Number 4 common permits waste, is of low quality, and may have coarse features such as decay and holes. It is used for sheathing, subfloors, and roof boards in the cheaper types of construction, but its most important industrial outlet is for boxes and crates.
      - (e) Number 5 common is not produced in some kinds of lumber. It is used for boxes, crates, and dunnage, for which the quality requirement is very low.
    - (3) Sizes.
      - (a) Nominal. The original size of the lumber after it is cut out of the log and before it is dried. Lumber is ordered and called by its nominal size (Table 051-236-1184-1).

**Performance Steps**

<b>Nominal Size (in inches)</b>	<b>Dressed Size (in inches)</b>
1 x 3	$\frac{3}{4}$ x 2 $\frac{1}{2}$
1 x 4	$\frac{3}{4}$ x 3 $\frac{1}{2}$
1 x 6	$\frac{3}{4}$ x 5 $\frac{1}{2}$
1 x 8	$\frac{3}{4}$ x 7 $\frac{1}{4}$
1 x 10	$\frac{3}{4}$ x 9 $\frac{1}{4}$
1 x 12	$\frac{3}{4}$ x 11 $\frac{1}{4}$
2 x 4	1 $\frac{1}{2}$ x 3 $\frac{1}{2}$
2 x 6	1 $\frac{1}{2}$ x 5 $\frac{1}{2}$
2 x 8	1 $\frac{1}{2}$ x 7 $\frac{1}{4}$
2 x 10	1 $\frac{1}{2}$ x 9 $\frac{1}{4}$
2 x 12	1 $\frac{1}{2}$ x 11 $\frac{1}{4}$
3 x 8	2 $\frac{1}{2}$ x 7 $\frac{1}{4}$
3 x 12	2 $\frac{1}{2}$ x 11 $\frac{1}{4}$
4 x 12	3 $\frac{1}{2}$ x 11 $\frac{1}{4}$
4 x 16	3 $\frac{1}{2}$ x 15 $\frac{1}{4}$
6 x 12	5 $\frac{1}{2}$ x 11 $\frac{1}{2}$
6 x 16	5 $\frac{1}{2}$ x 15 $\frac{1}{4}$
6 x 18	5 $\frac{1}{2}$ x 17 $\frac{1}{2}$
8 x 16	7 $\frac{1}{2}$ x 15 $\frac{1}{2}$
8 x 20	7 $\frac{1}{2}$ x 19 $\frac{1}{2}$
8 x 24	7 $\frac{1}{2}$ x 23 $\frac{1}{2}$

Table 051-236-1184-1  
Nominal and dressed size of lumber

(b) Actual. The size of the lumber after drying and surfacing.

EXAMPLE: Nominal size - 2 inches by 4 inches; actual size - 1 1/2 inches by 3 1/2 inches

(c) Length. The length is usually cut in 8-, 10-, 12-, 14-, 16-, 18-, and 20-foot increments.

(4) Classifications.

(a) Softwood. Evergreen and needle bearing trees such as cedar, cypress, fir, hemlock, pine, redwood, and spruce. This is not based on the actual softness of the wood.

(b) Hardwood. Broad leaved, deciduous trees such as birch and elm.

(c) Mahogany, oak, and walnut.

(5) Surfaces.

(a) Rough. Lumber which has been cut to nominal dimensions and not surfaced or dressed.

(b) Surfaced or dressed. Rough lumber which has been planed on one or more sides or edges to attain smoothness and uniformity.

(c) Worked. Surfaced or dressed lumber which has been matched such as tongue and groove, ship lapped, or patterned.

(6) Defects and blemishes.

(a) Defect. Any flaw that affects the strength, durability, or utility value of the lumber.

(b) Blemish. A flaw that mars only the appearance of the lumber, but does not affect the durability or utility value.

b. Plywood. Three or more thin sheets (plies) of wood glued together to form a panel.

(1) Advantages.

(a) It is one of the strongest materials available for woodworking.

**Performance Steps**

- (b) It can be worked easily and accepts nails without splitting.
- (c) It is versatile and can be finished or left to the weather.
- (2) Sizes.
  - (a) The most common size is 4 foot by 8 foot.
  - (b) The most common thickness range is from 1/8 inch to 1 inch. It can be specially ordered in a variety of thicknesses.
- (3) Types.
  - (a) Interior. Plywood can withstand an occasional wetting, but should not be permanently exposed to the elements.
  - (b) Exterior. Plywood is Intended for permanent exterior use and is bonded with waterproof adhesives.
- (4) Grades. Based on the quality of the plywood .
  - (a) A - grade. Highest standard grade with no open defects.
  - (b) B - grade. Has a solid face and tight knots.
  - (c) C - grade. One-inch splits limited to 1/8-inch wide and knotholes limited to 1/4 inch by 1 1/2 inches.
  - (d) D - grade. The poorest grade. It has open spaces.

## 2. Identify fasteners. The three types of fasteners are--

## a. Nails. Nails are the most used fastening device in construction.

- (1) Size. The size of a nail is measured in a unit known as a penny. Penny is abbreviated with the lower case letter "d." The "d" indicates the length of the nail.
- (2) Types and uses.
  - (a) Common wire nail. Used when appearance is not important, such as in framing or structural construction.
  - (b) Box nail. Used for toenailing and light work in frame construction.
  - (c) Casing nail. Used in finished carpentry work to fasten doors and window casings and other wood trim.
  - (d) Finishing nail. It has a small, tulip shaped head that can be set below the surface and easily puttied. It is used for interior finish.
  - (e) Brad nail. Used for light, wood-trim material and is easy to drive below the surface of lumber with a nail set.

NOTE: Refer to FM 5-426 for nail types and sizes.

- (f) Annular (ring) and spiral (screw) nails. These nails are threaded for greater holding power. They are good for fastening paneling or plywood flooring.
- (g) Drywall nail. Used for hanging drywall and has a special coating to prevent rust.
- (h) Roofing nail. It is a short length, large head nail that is resistant to weather. It is used to fasten flexible roofing materials, such as shingles and felt paper.
- (i) Duplex-head or double-head nail. Used for temporary construction, such as form work or scaffolding. The double head on this nail makes it easy to pull out when forms or scaffolding are torn down.

## b. Wood screws.

- (1) Advantages.
  - (a) Provides more holding power.
  - (b) Tightens easily to draw the items being fastened securely together.
  - (c) Neater in appearance if properly driven.
  - (d) Withdraws without damaging the material.
- (2) Designs. It is designed according to the head style (Figure 051-236-1184-1).

**Performance Steps**

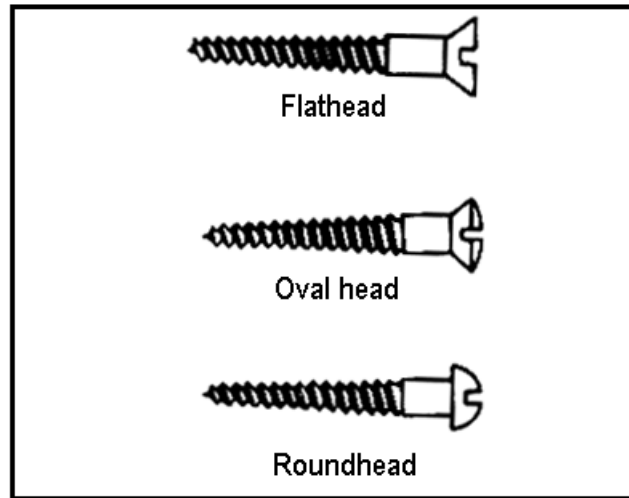

Figure 051-236-1184-1  
Wood screws head styles

- (a) Flat head.
  - (b) Oval head.
  - (c) Round head.
- (3) Sizes. It comes in sizes that vary from 1/4 inch to 6 inches and vary in the size of the shaft. The size number indicates the wire gauge of the body.
- c. Bolts. Bolts are used when great strength is required or when work must be frequently disassembled.
- (1) Carriage bolts.
    - (a) Round headed and are not designed to be driven.
    - (b) Threaded only part of the way up the shaft.
    - (c) The upper part of the shank is designed to grip the material and keep the bolt from turning when a nut is tightened down or removed (Figure 051-236-1184-2).

**Performance Steps**

Figure 051-236-1184-2  
Carriage bolts

- (2) Machine bolts.
- (a) These bolts are precision made and are generally applied metal to metal where close tolerance is desirable.
  - (b) The head may be square, hexagonal, rounded, or flat countersunk (Figure 051-236-1184-3).

**Performance Steps**

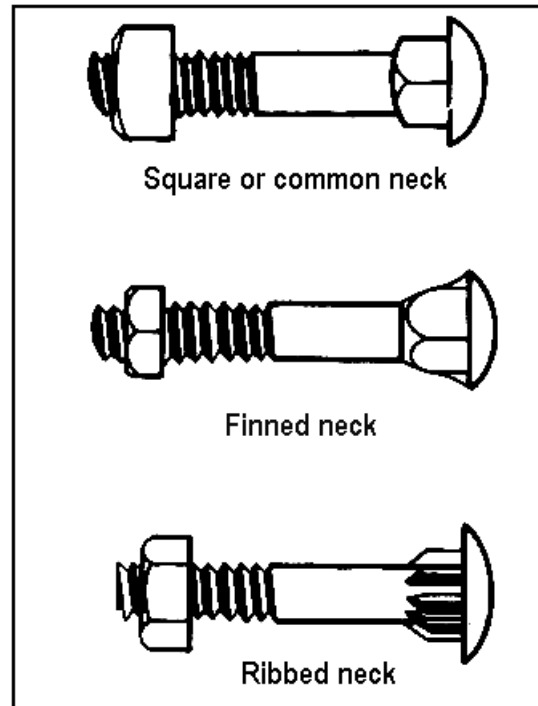
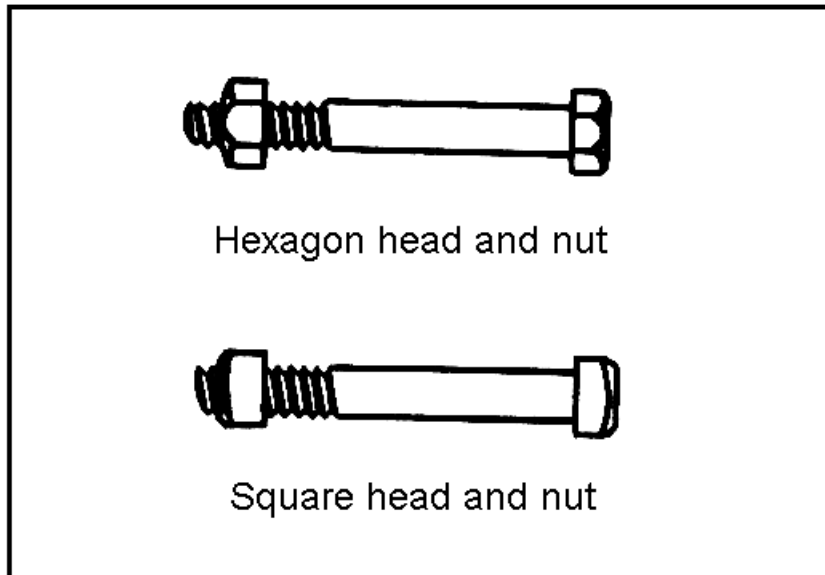

Figure 051-236-1184-3  
Machine bolts

- (3) Expansion bolts. Used in conjunction with an expansion shield to provide anchorage in substances in which a threaded fastener alone is useless (Figure 051-236-1184-4).

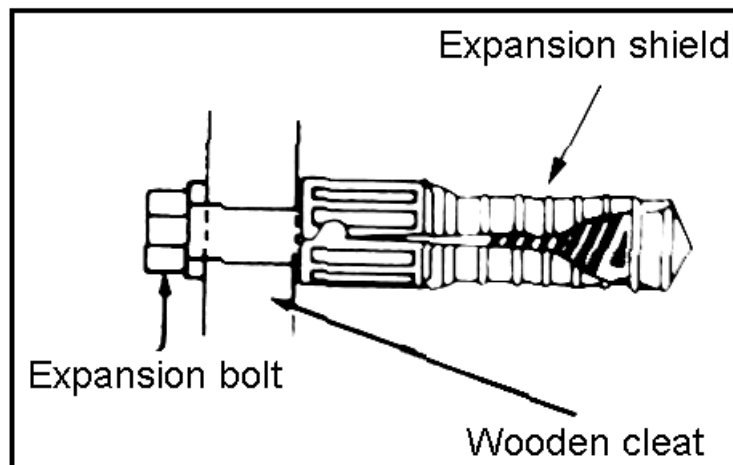

Figure 051-236-1184-4  
Expansion bolt and shield

- (4) Stove bolts. These bolts are less precisely made than machine bolts. They are generally used with square nuts and may be applied metal to metal, wood to wood, or wood to metal (Figures 051-236-1184-5).

**Performance Steps**

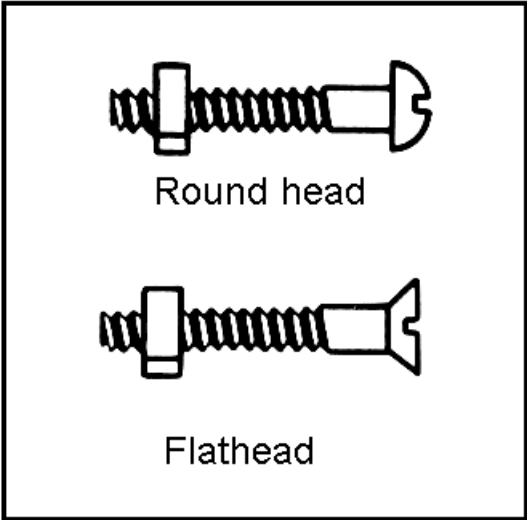

Figure 051-236-1184-5  
Stove bolts

**Evaluation Preparation:** Setup: Provide the soldier with the items listed in the conditions. Brief soldier: Tell the soldier to identify building materials by answering written questions pertaining to lumber, plywood, and common hardware according to FM 5-426.

<b>Performance Measures</b>	<b>Results</b>	
1. Identified building materials.	P	F
2. Identified fasteners.	P	F

**Evaluation Guidance:** Score the soldier GO if all steps are passed (P). Score the soldier NO-GO if any step is failed (F). If the soldier fails any step, show him how to do it correctly.

**References**  
**Required**  
FM 5-426

**Related**

## Subject Area 7: Building Layout and Foundations

**INSTALL BATTER BOARDS****051-236-1162**

**Conditions:** As a carpentry and masonry specialist in a field environment, given Field Manual (FM) 5-426, a prepared ground construction site with structure corners rough staked out, construction drawings, the required lumber and string, a measuring tape, a carpenter's level, a line level, a crosscut handsaw, a hammer, a sledge hammer, the required nails, and a specified starting point.

**Standards:** Installed batter boards so that the corner posts were 3 feet to 4 feet from the structure's corner stakes. Strung the board height within  $\pm 1/8$  inch of the required elevation and the corners within  $\pm 1/16$  inch of the diagonal measurement of the 6-8-10 method of determining square.

**Performance Steps**

NOTE: Refer to FM 5-426.

1. Lay out the site.
  - a. Use the following tools when laying out a site:
    - (1) Use a sledge hammer to sink corner stakes or batter board posts. In some soils, a posthole auger may be necessary.
    - (2) Use a handsaw to cut stock for batter boards and posts.
    - (3) Sharpen stakes and posts with an ax or hatchet.
    - (4) Use a hammer and nails to construct batter boards.
    - (5) Use a carpenter's level to determine level surfaces and sight level lines.
    - (6) Use a level to level string lines.
    - (7) Use a plumb bob to locate the corners of the building's dimensions.
    - (8) Use string line to distinguish the dimensions of the building.
    - (9) Use a tape measure for measuring diagonal measurements and for laying out excavation or foundation lines.
    - (10) Use a framing square to ensure that the lines are square.
  - b. Lay out and prepare a rectangular building site (Figure 051-236-1162-1).

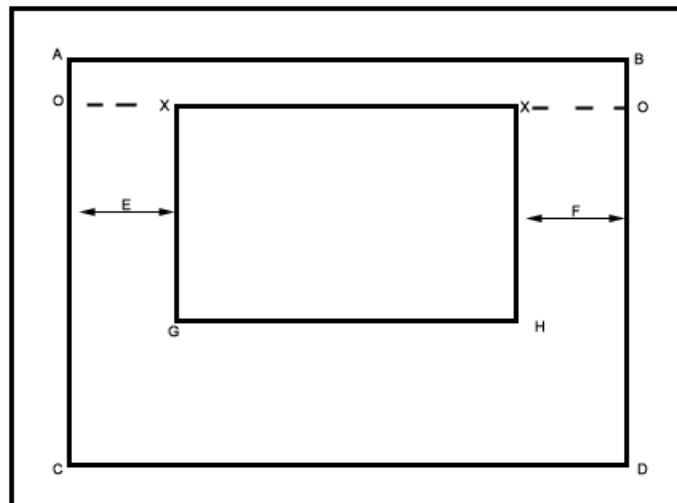

Figure 051-236-1162-1  
Laying out a rectangle



**Performance Steps**

- (1) Work from an established line (or front line), such as a road or property line, parallel to construction and establish the maximum outer perimeter (AB, CD, AC, BD) of the building area.
- (2) Measure away from the front line (AB) along the side lines (AC and BD) the distances (AO and BO) to the desired dimensions of the project that is to run parallel to the front line.
- (3) Stretch a line from point O on the left-side dimension to point O on the right-side dimension. This marks the frontage of the project.
- (4) Measure in from lines AC and BD along line OO one half the difference between the length of line OO and the actual dimension of the project parallel to lines AB. This will designate the measurement for points X. Both points X represent the two front corners of the project.

EXAMPLE: If line OO = 30 feet and if the actual dimension of the project parallel to lines AB = 20 then, 30 feet - 20 feet = 10 feet (difference between the OO and actual dimension of the project)

10 feet divided by 2 = 5 feet between the property line and the actual project on all sides

- (5) The two distances OX and XO establish distances E and F. Extend lines from the two front corner points X and X, parallel to lines AC and BD respectively, for the other required dimension of the rectangle or project. This provides sidelines XG and XH.
  - (6) Join point G and H to provide the rear line of the rectangle or project (GH).
  - (7) Drive stakes at each corner once each of the four-corner points (X, X, G, and H) have been located. Erect batter boards at this time.
- c. Lay out an irregular building site (Figure 051-236-1162-2).

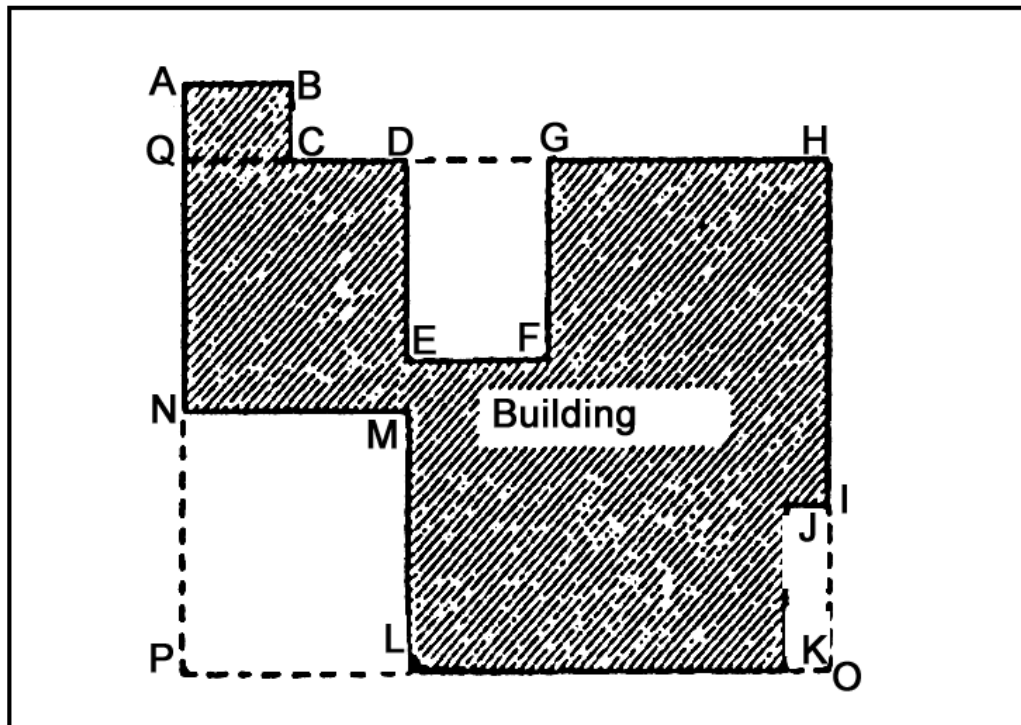

Figure 051-0236-1162-2  
Laying out irregular projects

NOTE: This procedure is relatively the same as laying out a single rectangle.

- (1) Lay out a large rectangle which represents the entire building or the greater part of it.

**Performance Steps**

NOTE: Refer to points H, O, P, and Q.

- (2) Lay out the remaining portion of the layout in small rectangles, each of which is laid out separately.

NOTE: Refer to angles LMNP, ABCQ, DEFG, and IJKO.

2. Use the following setting and staking procedures:
  - a. Set batter boards.
    - (1) Use 2- by 4-inch or 4- by 4-inch material to make batter board posts.
    - (2) Use 1- by 4-inch or 1- by 6-inch material to make batter boards.
    - (3) Use 2- by 2-inch material to make corner stakes.
  - b. Use the following staking procedures:
    - (1) Drive corner stakes to mark the exact corners of the project.
    - (2) Use batter boards to preserve definite and accurate building lines since corner stakes will be disturbed during excavation.
3. Determine the location of the batter boards and construct them.
  - a. Determine the location of the batter boards.
    - (1) Erect right angle batter boards 3 feet to 4 feet outside of each corner stake.
    - (2) Stake straight batter boards 3 feet or 4 feet outside of the line stakes.
    - (3) Stretch heavy cord or fine wire from one batter board to another to mark the building lines.
  - b. Construct batter boards.
    - (1) Fasten right-angle batter boards to the posts after the posts are driven into the ground.
    - (2) Fasten batter boards at the exact height of the top of the foundation.
    - (3) Erect right angle batter boards by using a framing square to ensure that the boards are as close to perpendicular as possible. Ensure that the batter board is level by using a carpenter's level before nailing the batter board in place.
    - (4) Saw notches or grooves or drive nails into the top of the batter board to hold the lines in place.
    - (5) Use separate grooves or nails to indicate the building line, foundation line, footing line, or excavation line. The grooves permit removal of the line as needed and replacement of the lines in the correct position.
4. Extend and square lines (Figure 051-236-1162-3).
  - a. Perform a simple layout.

Performance Steps

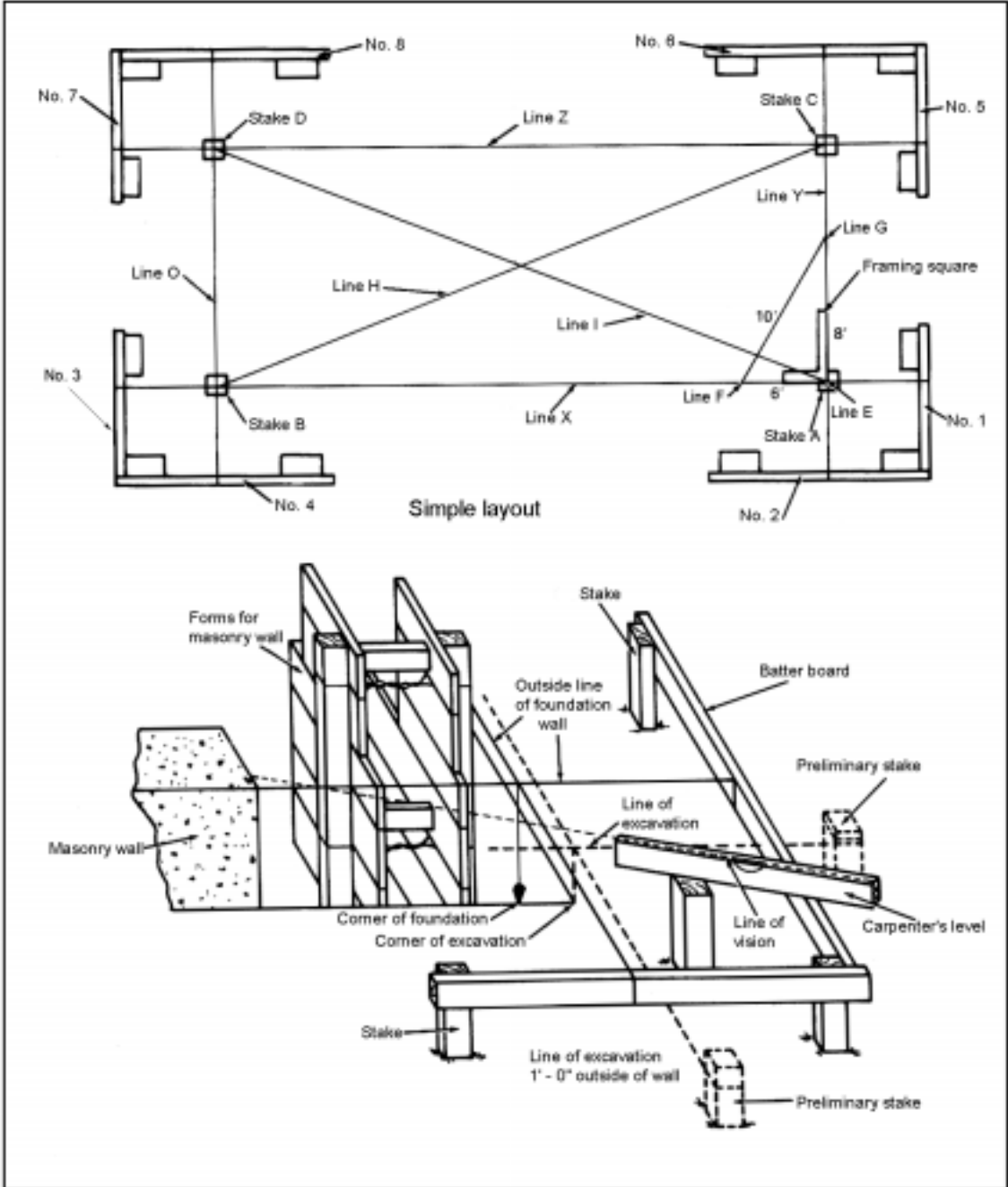

Figure 051-236-1162-3  
Typical corner layout

NOTE: Use the solution steps provided below to establish a building layout.

Step 1. Follow the placement of stakes A and B, erect batter boards number 1 through 4. Extend a chalk line (X) from the batter board numbers 1 to 3, over stakes A and B.

Step 2. Follow the placement of stake C, erect batter boards number 5 and 6. Extend chalk line (Y) from

**Performance Steps**

batter boards number 2 and 6, over stakes A and C.

Step 3. Follow the placement of stake D, erect batter boards number 7 and 8. Extend chalk line (Z) from batter board number 5 to 7, over stakes C and D.

Step 4. Extend line (O) from batter boards number 8 to 4, over stakes D and B.

- (1) Lay out dimensions for excavation lines, footer lines, or reference lines other than building lines. Use the building line marks on the batter boards as a reference. Adjust the measurement as required to obtain the desired dimensions for the reference line.

NOTE: Lines may cross and form right angles at the corner layout stakes.

- (2) Verify exact placement of the cross lines by holding a plumb bob over the corner layout stake. Adjust the lines until the lines intersect or touch the plumb bob line.
- (3) Use a line or carpenter's level to ensure that the lines are level.
- b. Square the lines using the following two methods:
  - (1) 6-8-10 method.
    - (a) Measure line EF for a distance of 6 feet.
    - (b) Measure line EG for a distance of 8 feet.
    - (c) Adjust lines (Y and X) until FG = 10 feet.
  - (2) Diagonal method. Use the diagonal method for a rectangular or square shaped layout. Refer to FM 5-426.
    - (a) Measure diagonal lines H and I.
    - (b) If lines H and I are equal in length, then the rectangle is perfect and the corners are square.
    - (c) Adjust the corners by moving the lines left or right until lines H and I are equal, if lines H and I are not equal in length.

5. Install batter boards.

- a. Lay out the site.
  - (1) Establish the maximum outer perimeter.
  - (2) Establish the desired distance at which the project will parallel the established front line.
  - (3) Establish the rear line.
  - (4) Establish the sidelines.
- b. Set and stake batter boards. Drive the corner stakes to mark the exact corners of the project.
- c. Locate and construct batter boards.
  - (1) Drive the posts into the ground.
  - (2) Fasten the right-angle batter boards with a framing square to ensure that the boards are perpendicular.
  - (3) Use a carpenter's level to level the batter board before nailing.
  - (4) Saw grooves or notches and run the string lines.
- d. Extend and square the lines.
  - (1) Use the plumb bob over the corner layout stake and adjust the lines until the lines intersect or touch the plumb bob line.
  - (2) Check all the lines for levelness by using a line level or carpenter's level.
  - (3) Square the lines by using both the 6-8-10 and the diagonal method.

**Evaluation Preparation:** Setup: Provide the soldier with the items listed in the conditions. Brief soldier: Tell the soldier to install batter boards using the diagonal method or the 6-8-10 method of determining the square. The soldier must be within +/- 1/16 inch of the measurement.

**Performance Measures**

**Results**

- |   |   |   |
|---|---|---|
| 1. Laid out the site.                   | P | F |
| 2. Used setting and staking procedures. | P | F |

**Performance Measures****Results**

3. Determined the location of the batter boards and constructed them.	P	F
4. Extended and squared lines.	P	F
5. Installed batter boards.	P	F

**Evaluation Guidance:** Score the soldier GO if all steps are passed (P). Score the soldier NO-GO if any step is failed (F). If the soldier fails any step, show him how to do it correctly.

**References****Required**

FM 5-426

**Related**

Subject Area 8: Wood Structures

**CONSTRUCT A FLOOR SYSTEM**

**051-236-1141**

**Conditions:** As a carpentry and masonry specialist in a field environment, given Field Manual (FM) 5-426, construction prints and specifications, a carpenter's tool kit, a completed masonry wall, plywood, 2- by 6-inch and 2- by 4-inch lumber, nails, a circular saw, an electric drill, saw horses, goggles, hearing protection, a hard hat, paper, and a pencil.

**Standards:** Identified the components of a floor system, calculated the component lengths, and installed the components of a floor system according to FM 5-426 and the construction prints and specifications. Calculated all the measurements to the nearest 1/16 inch. Installed sill plates without pulling the anchor bolts from the masonry wall. Installed the floor and header joists with the crown up. Staggered the solid bridging and secured 1/2-inch off center. Installed the subflooring to ensure that the ends of the panel were on the center of the joists. Performed all operations without damage to equipment or the environment and without injury to personnel.

**Performance Steps**

NOTE: Refer to FM 5-426.

1. Identify the following wood sill types and their construction (Figure 051-236-1141-1):

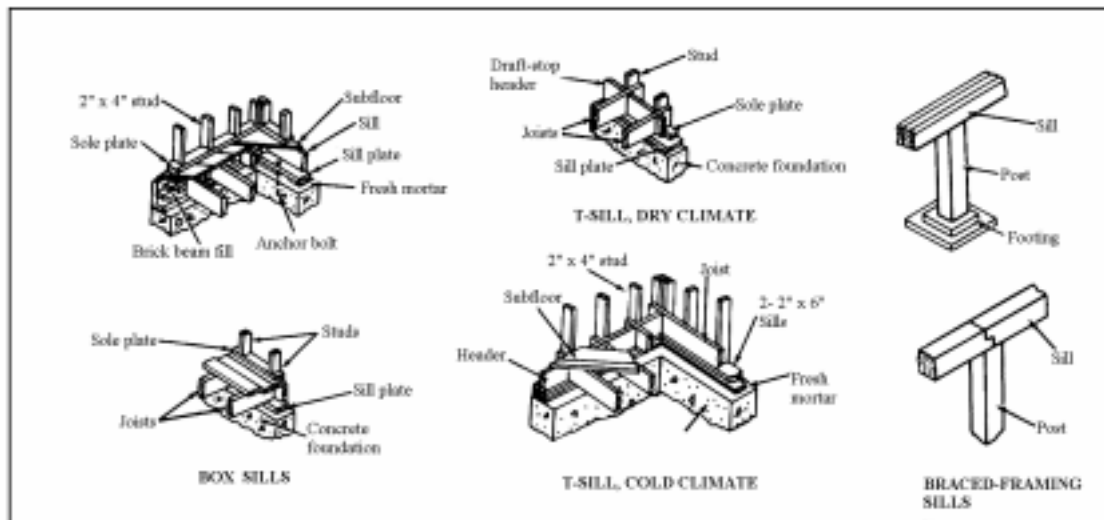

Figure 051-236-1141-1  
Types of sills

- a. Box sill.
  - (1) Use with platform framing.
  - (2) Use with or without a sill plate.
  - (3) Anchor the sill or sill plate to the foundation wall for support and fasten the joists with a header joist at the end of the joists, and rests on the foundation wall.

NOTE: In platform construction, the edge of the sill or header joist is set back from the outside face of the foundation a distance equal to the thickness of the exterior sheathing.

- b. T-sill (balloon-framed construction). T-sills are commonly used with balloon-framed construction. The two types of T-sills are the--
  - (1) Dry climate which is used in dry, warm climate. No header or draft stop is used.

**Performance Steps**

- (2) Cold climate which is used in colder climates.
  - (a) Nail T-sills directly to the studs and sills.
  - (b) Nail the headers or draft stops between the floor joists.
- c. Braced-framing sill.
  - (1) Use in braced-frame construction.
  - (2) Notch and nail the floor joists directly to the sill and joists.
- d. Built-up sill.
  - (1) Use in post-type or expedient-foundation systems when heavy, single-timber members are not available.
  - (2) Make built-up sills with two or more light timbers, such as 2- by 4-inch lumber.
  - (3) Position the joints directly over the posts.
  - (4) Select the sill size depending on the load to be carried and the distance between the posts.
  - (5) Place built-up sills, for expedient construction, directly on graded earth with the studs nailed directly to the sill.

2. Construct girders. Girders are large beams that support other beams or joists.

- a. Determine what kind of material to use.

NOTE: Use a girder when the distance between two walls is too great to be spanned by a single joist length.

- (1) Make a girder of timber, steel, reinforced concrete, or a combination of these materials.
- (2) Use wood, a more common material, for girders in light-frame construction.
- (3) Ensure that the girders are rigid and properly supported to carry the large part of the building's weight, which the girder supports.
- (4) Ensure that the ends of the wood girders can bear at least 4 inches on each post.
- b. Determine the requirements and the size of the girder.
  - (1) Determine the distance between the girder posts.
  - (2) Determine the girder load area.
  - (3) Determine the total floor load on the girder per square foot.
  - (4) Determine the load on the girder per linear foot.
  - (5) Determine the total load on the girder.
  - (6) Determine the material to be used.
- c. Identify built-up girders. Built-up girders warp less easily than solid wooden girders.
  - (1) Ensure that built-up girders are made up of at least three pieces of framing lumber and are nailed together.
  - (2) Ensure that they are made of lumber that is free of knots and defects.
  - (3) Ensure that the end grain of each piece of lumber does not run in the same direction. This allows for gained strength in the built-up girder.
  - (4) Ensure that the nailing pattern starts 1 1/2 inches from the ends in a square pattern and then a diagonal pattern every 16 inches. Use 16d nails.
- d. Identify when to use spliced girders.
  - (1) Use built-up girders to--
    - (a) Ensure that the lumber pieces are long enough so that only one joint occurs over the span between the posts or footings.
    - (b) Ensure that the lumber is square at the spliced joint and butted tightly together.
  - (2) Make solid-beam splices using a half-lap or butt joint.
- e. Identify the following girder supports (columns or posts):
  - (1) Wooden columns.
    - (a) Ensure that wooden columns are solid or have several pieces of lumber nailed together with 16d or 20d nails.
    - (b) Coat the base with asphalt to prevent rotting.
  - (2) Metal columns. Make metal columns of heavy pipe, large steel angles, or I-beam material.

**Performance Steps**

NOTE 1: Columns usually have a bearing plate at the top and bottom of each column to distribute the load evenly across the column.

NOTE 2: Fasten columns securely at the top with a cap or scabbing and at the bottom by using a doweled masonry footing or other suitable footing.

3. Construct floor joists.
  - a. Make floor joists.
    - (1) Make floor joists from wooden materials made of 2- or 3-inch thick material that make up the body of the floor frame.
    - (2) Nail the flooring or subflooring to the joists.
    - (3) Make floor joists from material as small as 6 inches in width, depending on the load and the application.
  - b. Space floor joists.
    - (1) Space floor joists 16 or 24 inches apart, center to center.
    - (2) Double the floor joists to support heavier loads or a partition wall or they can be blocked, center to center spacing may be reduced, or a combination thereof.
  - c. Connect and anchor floor joists.
    - (1) Connect floor joists to sills.
      - (a) Ensure that the connection can carry the load the joists will carry.
      - (b) Ensure that if the floor joist must be notched to fit a sill or girder, that the notch does not exceed one-third of the floor-joist depth to prevent splitting.
    - (2) Connect to girders (Figure 051-236-1141-2).

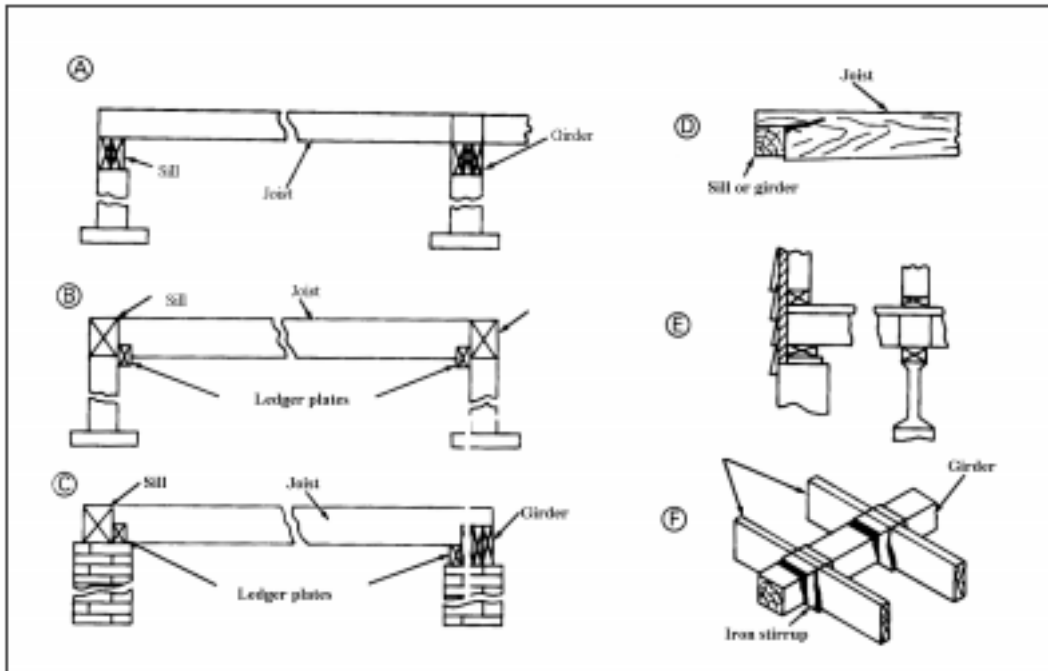

Figure 051-236-1141-2  
Sill and joist construction

- (a) Ensure that the floor joists are level when framed to the girders.
- (b) Notch the joists when the girder is not the same height as the sill.
- (c) Place floor joists crown side up.



**Performance Steps**

- ( d) Place floor joists on top of steel girders.
- d. Connect to ledger plates. Use ledger plates to assist in the support of the floor joists that are being attached to girders or sills.
  - (1) Nail a 2- by 4-inch piece of lumber to the face of the girder or sill, flush with the bottom edge. Nail these pieces at 12-inch intervals using 20d nails.
  - (2) Notch joists 10 inches in depth or greater for ledger plates without jeopardizing the strength of the joists.
  - (3) Use joist ties, in addition to the ledger plate, to help overcome the loss of strength when joists are notched.
- 4. Identify floor joists for platform construction.
  - a. Check the plans and specifications to determine the size and direction of the floor joists.
  - b. Use FM 5-426, Tables 6-2 and 6-3, to size and space floor joists in the absence of the specifications.
- 5. Construct floor bridging.
  - a. Bridge floor frames to prevent floor joists from twisting and deflecting.
  - b. Bridge floor joists to stiffen the joists and enable an overloaded joist to transfer some of the load to adjacent joists.
  - c. Use cross bridging more often because it is highly effective and requires less time to install than other methods.
    - (1) Construct cross bridging of diagonally cut 1- by 3-inch or 2- by 3-inch dimensional lumber placed between the floor joists.
    - (2) Ensure that cross bridging members touch together at the cross and the cross bridging is nailed to the top edge of the joists using only 8d or 10d nails.
    - (3) Ensure that the bottoms of cross bridging members are left unattached until the subfloor has been laid. This allows the joists to adjust to their final position and keeps the bridging from pushing up the joists, causing the floor to become uneven.
    - (4) Place one row of bridging on joists spanning more than 8 feet.
    - (5) Use two equally spaced rows of bridging on joists spanning more than 16 feet.
  - d. Use solid bridging as an alternate method to cross bridging. Solid bridging generally takes more time to install and requires more material than cross bridging.
    - (1) Use material for solid bridging that is normally the same size dimension lumber as the floor joist being bridged.
    - (2) Offset each piece of bridging to make nailing easier. Nail directly through the joists into the end of the bridging.
  - e. Use compression bridging as an alternate method to cross bridging.
    - (1) Ensure that compression bridging consists of cross bridging. Use a factory constructed, rigid-metal bridge.
    - (2) Make the compression bridge member with a nailing flange and fasten with 8d or 10d common nails.
- 6. Construct floor openings (Figure 051-236-1141-3).

**Performance Steps**

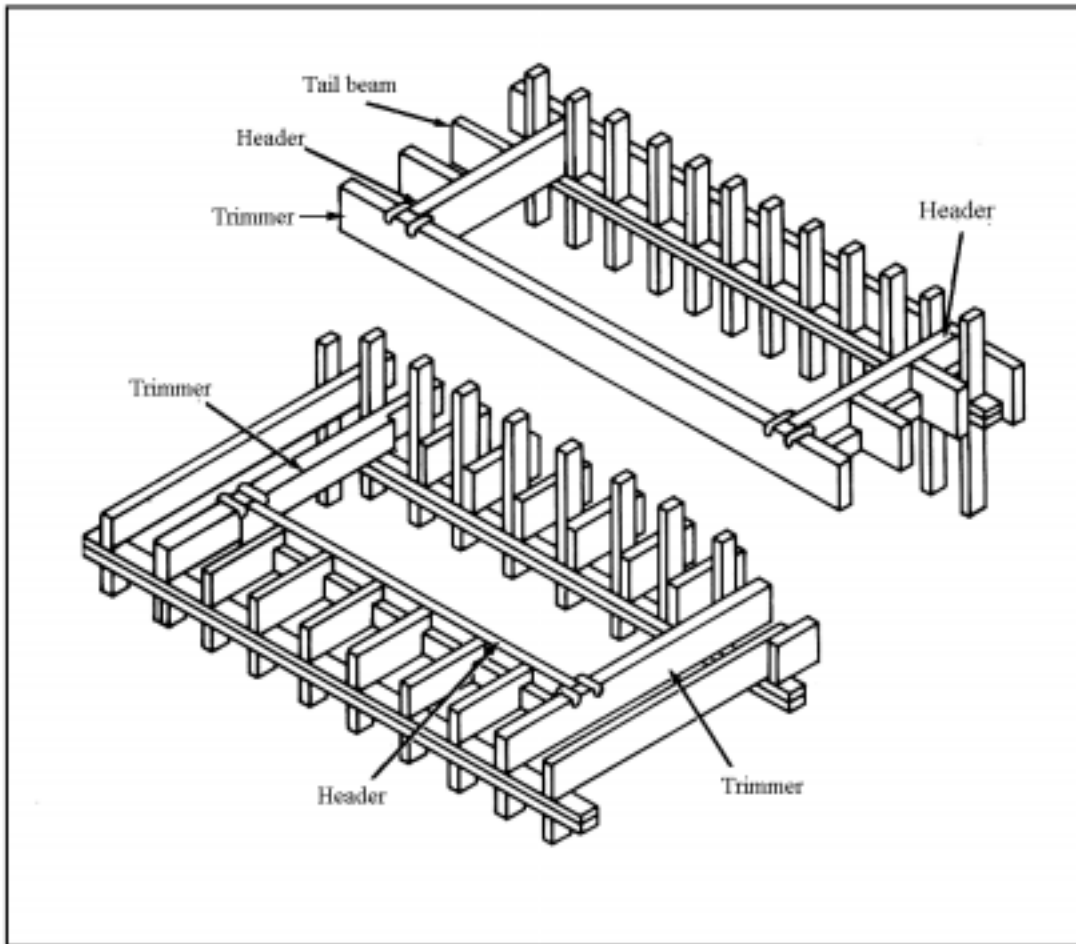

Figure 051-236-1141-3  
Floor openings

- a. Use a combination of members called headers and trimmers to frame floor openings for stairwells, chimneys, and other fixtures.
  - (1) Double the headers. Headers are members that run perpendicular to floor joists.
  - (2) Double the trimmers. Trimmers are members that run parallel with floor joists.
- b. Construct floor openings.
  - (1) Determine the number of headers and trimmers:
    - (a) Determine whether the shape of the floor opening is a rectangle or whether other additional angles must be considered.
    - (b) Determine the position of the floor opening in relation to the direction the joists are positioned.
    - (c) Determine the position of the floor opening in relation to the partitions and the walls.
  - (2) Determine the type of floor opening.
    - (a) Determine if a floor opening is parallel to the joists and uses two headers and one trimmer.
    - (b) Determine if a floor opening is perpendicular to the joists and uses one header and one trimmer.
    - (c) Determine if a floor opening is supported by a post at the corner angle.

**Performance Steps**

- (d) Determine if a floor opening is supported by a cantilever method using a partition for support.

NOTE: Use the following steps to construct a floor opening:

Step 1. Nail headers number 1 and number 2 to trimmers A and C with three 20d nails.

Step 2. Nail headers number 1 and number 2 to short joists X and Y with three 20d nails.

Step 3. Nail headers number 3 and number 4 to headers number 1 and number 2 with 16d nails.

Step 4. Nail trimmers A and C to headers number 3 and number 4 with three 20d nails.

Step 5. Nail trimmers B and D to trimmers A and C with 16d nails spaced 12 inches apart.

7. Identify the types of flooring and how to construct them.

a. Identify the following types of subflooring:

(1) Diagonal boards.

(a) Lay the subfloor diagonally on the joist framework and nail with 8d or 10d nails.

(b) Nail at least three nails per joist for subflooring board 8 inches wide or wider.

(c) Lay the subfloor before constructing the wall so the floor can be used during the wall construction.

(2) Plywood.

(a) Stagger all joints.

(b) Lay the sheets perpendicular to the floor joists.

b. Identify finished wood flooring.

(1) Ensure that a finished floor in theater of operations construction is made of 3/4-inch material, square edged, or tongue-and-groove.

(2) Ensure that finished flooring varies from 3 1/2 inches to 7 1/2 inches wide.

(3) Lay finished flooring directly on the floor frame or on the subfloor and nail with 8d nails at every joist.

(4) Use building paper between the subfloor and finished floor when a subfloor is used to keep out dampness and insects.

(5) Use 2- by 4-inch to 12-inch thick material for the finish floor, in areas where heavy loads are expected, and nail with 16d or 20d nails.

c. Construct concrete floors.

(1) Construct concrete floors where earthen or wood floors are not suitable, such as in maintenance repair or assembly shops.

(2) Refer to FM 5-472 for the construction of concrete floors.

d. Identify miscellaneous flooring, which includes earth, adobe brick, duckboard, or rushes.

(1) Use miscellaneous flooring materials when conventional flooring materials are either unavailable or the construction specifications indicate use of these types of flooring.

(2) Use duckboard flooring for shower flooring in theater of operations construction.

8. Determine the floor dimensions from prints and specifications.

a. Ensure that the floor framing plan specifies the following:

(1) Size and spacing of the joists.

(2) Size and numbers of girders.

(3) The bridging.

b. Determine how many floor joists will be needed by using the above information.

9. Calculate component lengths by using the following scenario and formula:

SCENARIO: Construct a 12- by 12-foot floor system. Construct sill plates, joists, and bridging by using 2- by 6-inch lumber. Install bridging at 6 feet on the floor joists. Space floor joists 16 inches on center. Calculate component lengths for the sill plates, header and floor joists, and bridging.

a. Sill plates 2 by 6 inches.

(1) Long wall length: 12 feet      Quantity: 2

**Performance Steps**

- (2) Short wall length: 11 feet 1 inch      Quantity: 2 (12 feet minus the width of the long wall 2- by 6-inch lumber [5 1/2 inches each]).
- b. Header joists: 2 inches by 6 inches      Length: 12 feet      Quantity: 2
- c. Floor joists: 2 inches by 6 inches
  - (1) Length: 11 feet 9 inches (12 feet minus the 3 inches from the thickness of both header joists)
  - (2) Quantity: 9

**FORMULA:**

Length in inches (144) divided by stud spacing (16) + 1  
 144 divided by 16 = 9 + 1 = 10

- d. Solid bridging.
  - (1) Length: 14 1/2 inches (as measured between floor joists)
  - (2) Quantity: 8

10. Calculate and determine the component lengths for a floor system using the following scenario.  
**SCENARIO:** Construct a 16- by 16-foot floor system. Use 2- by 12-inch lumber to construct sill plates, joists, and bridging. Install bridging every 4 feet on the floor joists and floor joists will be spaced 24 inches on center. Calculate component lengths for the sill plates, joists, and bridging.

- a. Sill plates 2 inches by 12 inches
  - (1) Long wall length: 16 inches      Quantity: 2
  - (2) Short wall length: 14 feet 1 inch      Quantity: 2 (16 feet minus the width of the long wall 2- by 12-inch lumber (11 1/2 inches each))
- b. Header joists: 2 inches by 12 inches      Length: 16 feet      Quantity: 2
- c. Floor joists: 2 inches by 12 inches
  - (1) Length: 15 feet 9 inches (16 feet minus the 3 inches from the thickness of both header joists)
  - (2) Number: 9

**FORMULA:**

Length in inches (192) divided by stud spacing (24) + 1  
 192 divided by 24 = 8 + 1 = 9

- d. Solid bridging.
  - (1) Length: 22 1/2 inches (as measured between floor joists)
  - (2) Quantity: 24 (count amount of spaces between joists)

11. Install floor-system components.

- a. Install the sill plates.
  - (1) Select 2- by 6-inch lumber from the lumber pile.
  - (2) Prepare the first sill section. Square cut the sill plates to length.
  - (3) Lay out the sill plates for anchor bolt holes.
    - (a) Lay out the sill pieces on top of the anchor bolts.
    - (b) Align and square the ends of the sill plates with the foundation walls.
    - (c) Tap the plates on the anchor bolts to make a slight indentation on the lumber.
  - (4) Bore holes for the anchor bolts with a brace and bit 1/4 inch larger than the diameter of the anchor bolts.
  - (5) Position the sill plates.
    - (a) Place the sill plates on the foundation walls over the anchor bolts.
    - (b) Place a nut on each bolt and hand tighten.
    - (c) Align and square the sill plates.
    - (d) Cinch the nuts on the anchor bolts with an adjustable wrench.

**NOTE:** At this point, check the quality of the work.

- b. Lay out and erect floor joists and solid bridging.
  - (1) Square and cut header joists to length.
  - (2) Lay out the header joists for the location of the floor joists.

**Performance Steps**

- ( a ) Place the two headers side by side so they can both be marked at the same time.
- ( b ) Measure in 15 1/4 inch from one end and square mark this point.
- ( c ) Place an "X" after the square mark (on the side away from the end from which you measured). This is the location of the first floor joist.

NOTE: Space joists 16 inches on center. The mark for the first joist is 15 1/4 inches to allow for half the thickness of the first joist.

- ( d ) From the 15 1/4-inch mark, square mark every 16-inch increment on the header joist, putting an "X" after each mark.
- ( e ) Square mark in 1 1/2 inch from each end of the header joist. Mark an "X" on the side towards the end. These are the locations of the starter joists.
- (3) Place the header and outside end joists on edge on the sill plates. Secure the joists with 16d duplex nails to form the "box." Ensure that the box is square by checking diagonals, and then secure it squarely to the sill with 16d duplex nails.
- (4) Prepare and install the floor joists.
  - ( a ) Square cut the required number of joists to the required length.
  - ( b ) Align the joists (crowns up) with the marks on the header joists.

NOTE: All material must be flush with the top edge of the header joists. The tolerance for spacing and level is +/- 1/8 inch.

- ( c ) Secure the floor joists with two 16d duplex nails through the header joists into both ends of each joist.
- (5) Prepare and install the solid bridging.
  - ( a ) Measure and record the dimensions and space numbers between the floor joists along one header joist.

NOTE: Do not measure the space between the floor joists in the center because the purpose of solid bridging is to help align the floor joists.

- ( b ) Square cut material of the required sizes.

NOTE: Cut away the line, otherwise the bridging will be too long.

- ( c ) Locate the midpoints on the opposite starter joists and snap a chalkline across the intervening joists.
- ( d ) Align the solid bridging alternately to one side or the other of the marks. Positioning must be within +/- 1/8 inch of these marks.
- ( e ) Secure the bridging with two 16d duplex nails driven through the joists into the bridging.

c. Install the plywood subfloor.

- (1) Lay the first sheet. Start the first sheet flush with the starter joist.

NOTE: The wood grain of all sheets must be perpendicular to the joists.

- (2) Lay the second sheet butt against the first sheet.

NOTE: Center all sheets and joints on a joist.

- (3) Lay the remainder of the sheets. Repeat the sheet laying process until the entire floor is covered.

- (4) Face nail the sheets with 6d common nails and 8 inches on center.

**Evaluation Preparation:** Setup: Provide the soldier with the items listed in the conditions. Brief soldier: Tell the soldier to identify the components of a floor system, calculate components lengths, and install the components of a floor system according to FM 5-426 and the construction prints and specifications.

**Performance Measures**

**Results**

1. Identified wood sill types and their construction.	P	F
2. Constructed girders.	P	F
3. Constructed floor joists.	P	F
4. Identified floor joists for platform construction.	P	F

<b>Performance Measures</b>	<b>Results</b>	
5. Constructed floor bridging.	P	F
6. Constructed floor openings.	P	F
7. Identified the types of flooring and how to construct them.	P	F
8. Determined the floor dimensions from prints and specifications.	P	F
9. Calculated component lengths.	P	F
10. Calculated and determined the component lengths for a floor system.	P	F
11. Installed floor-system components.	P	F

**Evaluation Guidance:** Score the soldier GO if all steps are passed (P). Score the soldier NO-GO if any step is failed (F). If the soldier fails any step, show him how to do it correctly.

**References**

**Required**  
FM 5-426

**Related**

## CONSTRUCT STAIRS

051-236-1143

**Conditions:** As a carpentry and masonry specialist in a field environment, given Field Manual (FM) 5-426, Naval Education Training Command (NAVEDTRA) 12521, construction prints and specifications, a carpenter's tool kit, a completed floor system, 2- by 12-inch lumber, 2- by 6-inch lumber, nails, a circular saw, a framing square, a calculator, saw horses, safety goggles, gloves, hearing protection, a hard hat, paper, and a pencil.

**Standards:** Identified components of a stairway, calculated lengths, and installed components of a stairway according to FM 5-426, NAVEDTRA 12521, and the construction prints and specifications. Calculated all measurements to the nearest 1/16 inch. Performed all operations without damage to equipment or the environment and without injury to personnel.

### Performance Steps

NOTE: In order to construct a stairway system, identify the components of a stairway-frame structure, calculate the component lengths for the stairway system, and then install stairway system components.

1. Identify the components of a stairway system. The components of a stairway system are the--
  - a. Tread. The horizontal face of a step.
  - b. Riser or unit rise. The riser or unit rise is the vertical face of a step.
  - c. Handrail post. Handrail posts support the handrail and is secured directly to the stair stringer.
  - d. Handrail. The top finishing piece on a railing that is used for grasping while going up and down the stairs.
  - e. Posts. Posts support the handrails and landing.
  - f. Stringers. Stringers support the tread and risers and are normally constructed of 2- by 12-inch lumber.
  - g. Landing. The floor at the top or bottom of each story where a section of stairs begins or ends.
2. Identify the typical interior stairway components. Typical interior stairway components include the--
  - a. Nosing. The projection of the tread beyond the face.
  - b. Stairwell double headers. The part of the floor system to which stairs may be secured.
3. Identify an alternate stairway. An alternate stairway includes the--
  - a. Cut-out stringer.
    - (1) Kick. The plate used to anchor the lower ends of the stringers to the floor.
    - (2) Nailing block. The nailing block is used to secure the stairway to the floor frame.
  - b. Simple stairway.
    - (1) Stringer. The stringer will not be cut out, but marked for treads with a pencil.
    - (2) Cleats. Small blocks of wood nailed to the stringer to which treads are to be secured.
    - (3) Plank treads. Treads that are secured to the cleats.
    - (4) Total rise. The total vertical distance from the floor to the next.
    - (5) Total run. The total horizontal distance of the stairs (Figure 051-236-1143-1).

**Performance Steps**

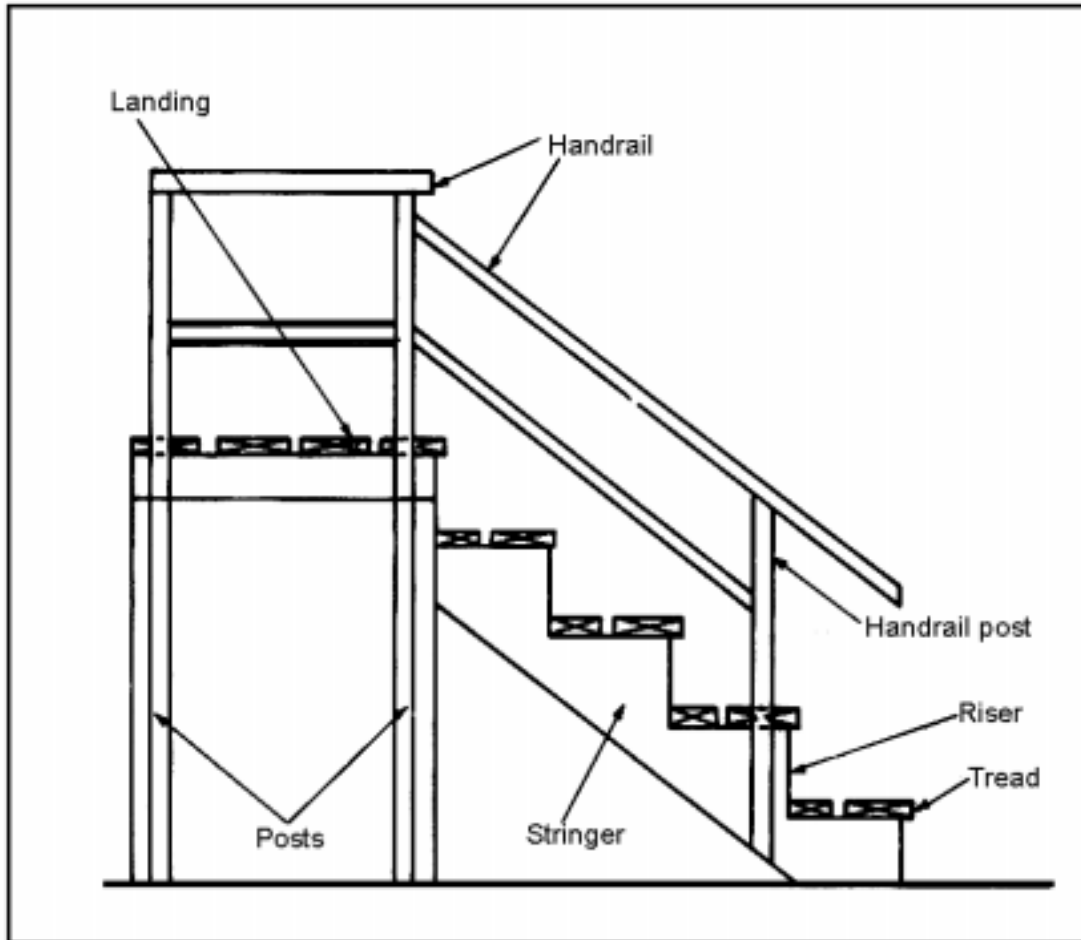

Figure 051-236-1143-1  
Typical stairway

4. Calculate the components of a stairway system and determine the stringer layout dimensions by using the following information:
    - a. Total rise. Use a square to mark the center of the door at the header joist and subfloor.  
 FORMULA: Total rise = the distance from the subfloor to subfloor + the thickness of the finished floor.  
 The distance from subfloor to subfloor = 2 foot 7 inches. The thickness of finished floor = 1 inch. The total rise = 2 foot 7 inches + 1 inch = 2 foot 8 inches.
    - b. Unit of rise.
      - (1) FORMULA: Unit of rise (steps) = total rise (in inches) divided by 7 inches (average height of each step). The total rise = 2 foot 8 inches. Convert to inches (2 foot 8 inches) = 24 inches + 8 inches = 32 inches). Units of rise (steps) = 32 inches divided by 7 = 4.57 = 5.
- NOTE: Round to the nearest whole number.



**Performance Steps**

- (2) FORMULA: Height of the units of rise - height of units of rise = total rise (inches) divide units of rise.

Total rise = 32 inches

Units of rise = 5

Height of units of rise = 32 inches divided by 5 = 6.4 = 6 3/8 inches

NOTE: Round to the nearest 1/16 inch.

c. Unit of run.

FORMULA: Unit of run = sum of unit run and unit rise (architect's rule = 17 1/2 inches) - height of units of rise.

(1) Architects rule = 17 1/2 inches

(2) Height of units of rise = 6 3/8 inches

(3) Unit of run = 17 1/2 inches - inches = 11 1/8 inches

NOTE: Round to the nearest 1/16 inch.

d. Total run.

FORMULA: Total run = unit of run x units of rise (steps)

(1) Unit of run = 11 1/8 inches

(2) Units of rise (steps) = 5

(3) Total run = 11 1/8 inches x 5 = 55 5/8 inches

e. Length of stringer.

FORMULA: Length of the stringer = the hypotenuse of a triangle with the total run as the base and the total rise as the altitude.

Use the Pythagorean Theorem ( $a^2 + b^2 = c^2$ ) to find the length.

NOTE: Ensure that you convert the inches to feet.

(1) Total rise = 32 inches (2.67 feet)

(2) Total run = 55 5/8 inches

(3) Length of the stringer =  $a^2 + b^2 = c^2$  (4.64 feet)

$$= 2.67^2 + 4.64^2 = c^2$$

$$= 7.13 + 21.53 = \sqrt{28.66}$$

$$= 5.35 \text{ feet} = 5 \text{ foot } 4 \frac{3}{16} \text{ inches}$$

5. Lay out a stringer for a stairway.

a. Construction consideration.

(1) Accuracy is required in laying out the stringer.

(2) Use a sharp pencil or awl when marking the stringer.

(3) Lines must meet on the edge of the stringer.

(4) Stringers are normally made from 2- by 12-inch stock.

b. Stringer layout with the framing square.

(1) Lay out the lower end of the stringer (Figure 051-236-1143-2).

**Performance Steps**

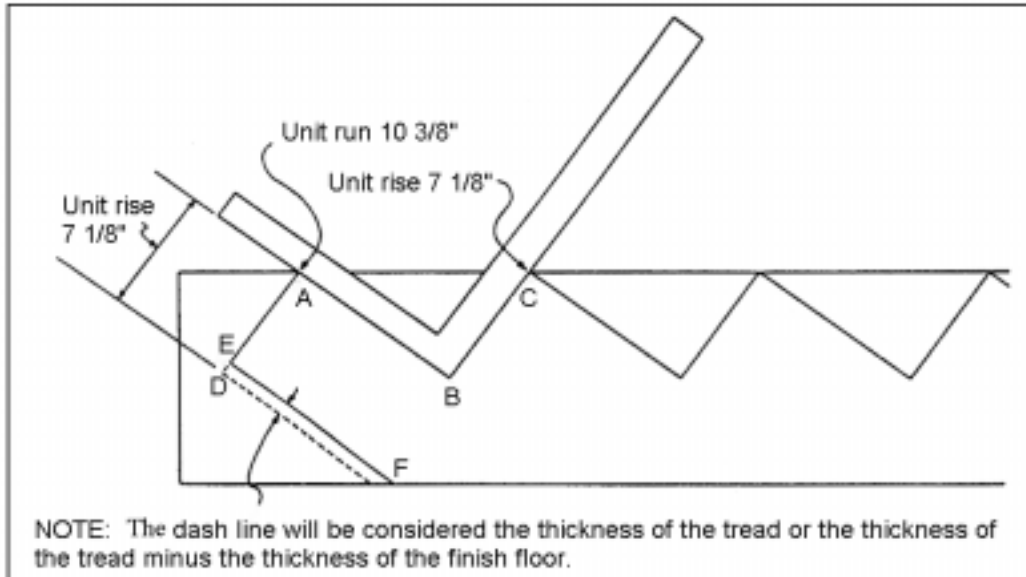

Figure 051-236-1143-2  
Layout of the lower end of the cutout stringer

- (a) Set the framing square, with the face side up, to the unit run (10 1/2 inches, on the tongue, and the height unit rise (7 inches) on the blade). Draw line AB. This line represents the bottom tread.
  - (b) Draw line BC. This line represents the second riser.
  - (c) Rotate the square 180 degrees and draw line AD at the measurement of the height of unit rise (7 inches) perpendicular to line AB. Line AD represents the first riser. If the bottom of the stringer will rest on the finished floor, shorten line AD by the tread thickness, which line AE represents. This is called dropping the stringer. If the bottom of the stringer will rest on the subfloor, shorten line AD by the tread thickness, which line AE represents. Next, adjust the first riser height by adding the thickness of the finished floor to the finished floor to the total length of the first riser.
  - (d) Rotate the framing square 90 degrees to the left and draw line EF parallel to line AB.
  - (e) Lay out the remaining risers and treads (for a total of 21 risers and treads according to the stringer design).
- (2) Lay out the upper end of the stringer.
- (a) Lay out the top of the stringer. Line AB represents the top tread.
  - (b) Rotate the framing square 90 degrees to the left and draw line BC. Line BC represents the vertical edge that is anchored to the stairwell header (Figure 051-236-1143-3).

**Performance Steps**

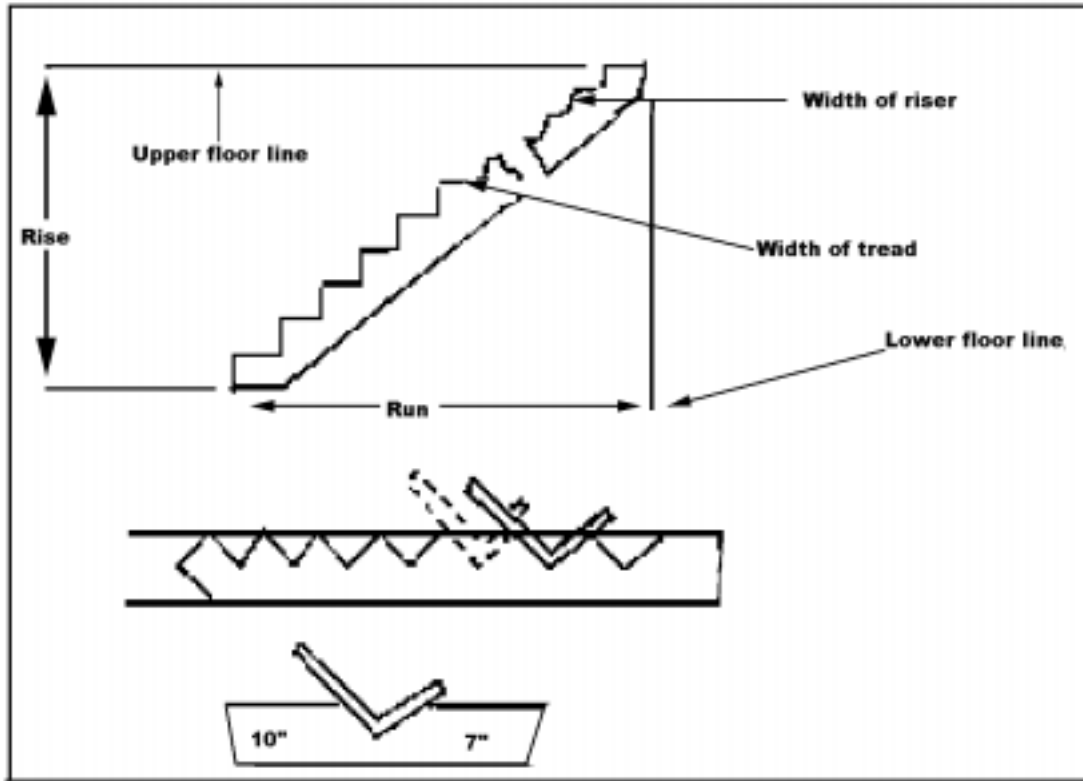

Figure 051-236-1143-3  
Step construction

**Evaluation Preparation:** Setup: Provide the soldier with the items listed in the conditions. Brief soldier: Tell the soldier to identify components of a stairway, calculate the lengths and install the components of a stairway according to FM 5-426 and the construction prints and specifications.

**Performance Measures**

**Results**

- |   |   |   |
|---|---|---|
| 1. Identified the components of a stairway system.  | P | F |
| 2. Identified the typical interior stairway components.   | P | F |
| 3. Identified an alternate stairway.  | P | F |
| 4. Calculated the components of a stairway system, and determined the stringer layout dimensions. | P | F |
| 5. Laid out a stringer for a stairway.  | P | F |

**Evaluation Guidance:** Score the soldier GO if all steps are passed (P). Score the soldier NO-GO if any step is failed (F). If the soldier fails any step, show him how to do it correctly.

STP 5-51B12-SM-TG

**References**

**Required**

FM 5-426

NAVEDTRA 12521

**Related**

**CONSTRUCT A ROOF SYSTEM****051-236-1144**

**Conditions:** As a carpentry and masonry specialist in a field environment, given Field Manual (FM) 5-426, construction prints and specifications, a carpenter's tool kit, a completed wall system, plywood, 2- by 6-inch lumber, nails, a circular saw, an electric drill, an extension cord, a power source, saw horses, safety goggles, hearing protection, a hard hat, paper, and a pencil.

**Standards:** Constructed a roof system according to FM 5-426 and the construction prints and drawings. Measurements did not exceed +/- 1/8 inch.

**Performance Steps**

**NOTE:** In order to construct a roof system, the soldier needs to identify the components of a roof system, calculate the component lengths for a roof system, then install the ceiling joists and rafters.

**NOTE:** Refer to FM 5-426 for the different types of roofs.

1. Identify the components of a roof system (Figure 051-236-1144-1). The roof system includes the--

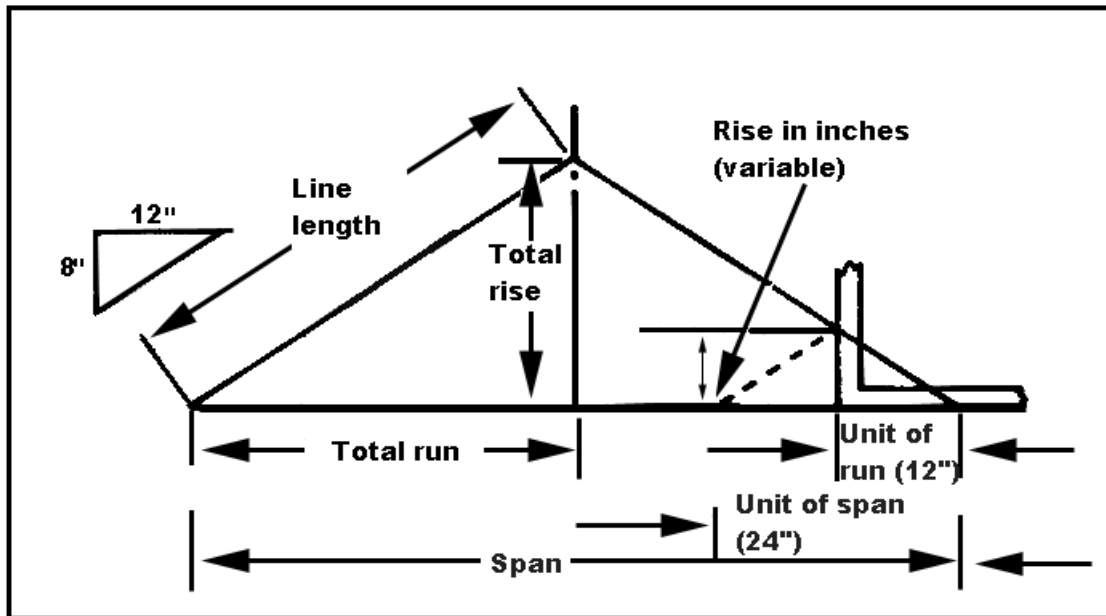

Figure 051-236-1144-1  
Determining roof pitch

- a. Basic roof frame (gable). The basic roof frame (gable) forms two right triangles. Roof framing terms are related to the parts of the triangle and include--
  - (1) Span. The distance between the outside top plates.
  - (2) Total run. The total run is half of the span, which is the base of one of the right triangles.
  - (3) Unit of run (or unit of measurement). Unit of run is a fixed measure and is always 12 inches for the common rafter.
  - (4) Total rise. The vertical distance from the top plate to the top of the ridge.
  - (5) Line length. The distance along the rafter from the outside edge of the top plate to the centerline of the ridge.

**Performance Steps**

- b. Pitch. The ratio of the unit of rise to the unit of span, expressed in a fraction.

EXAMPLE: 8-inch unit of rise = 1 pitch                      24-inch unit of span = 3 inches

- c. Cut or slope. The angle that the roof surface makes with a horizontal plane. This usually is expressed as a fraction with the unit of rise as the numerator and the unit of run (12 inches) as the denominator. It may also be expressed in inches per foot.

EXAMPLE: 8-inch unit of rise = 8 pitch                      12-inch unit of span = 12 inches

- d. Roof components.

- (1) Ceiling joists.
  - (a) Ceiling joists rest on the double top plate and holds the tops of the walls in place.
  - (b) Ceiling joists usually go in the same direction as the rafters and are spaced directly over the wall studs when spacing between the joist and studs is the same.
- (2) Common rafters. Common rafters are framing members that extend at right angles from the plate line to the roof line. They are usually spaced 16 to 24 inches on center.
- (3) Ridgeboard. The ridgeboard is the highest horizontal roof member and ties the rafters together at the upper end.
- (4) Roof sheathing. Sheathing is 4- by 8-foot sheets of plywood or composition. Composition sheathing is the most common type. Ensure that the plywood sheets are staggered in the same manner as they are when installing subfloors.

- 2. Install the ceiling joists. Refer to Naval Education Training Command (NAVEDTRA) 12521, Chapter 1.

- a. Measure the width of the structure outside to outside of the double top plate for the length of the joists.
- b. Lay out the top plate for the ceiling joists (Figure 051-236-1144-2).

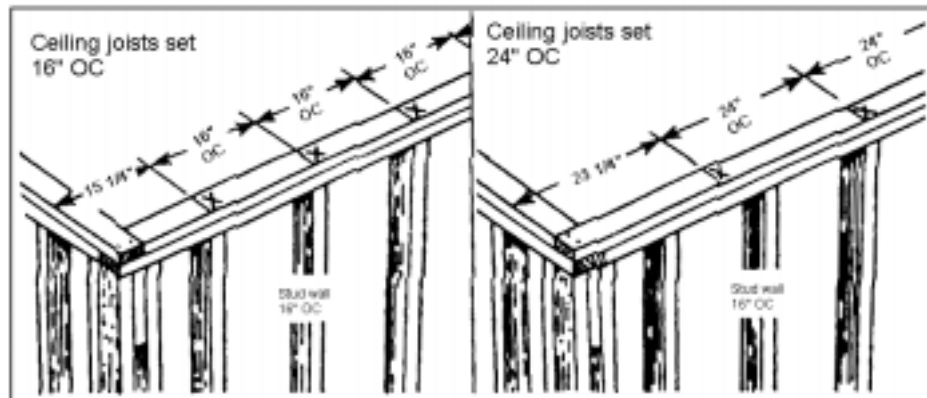

Figure 051-236-1144-2  
Ceiling joist spacing

- (1) Mark off 15 1/4 inches, from the outside corner of the building, (only if the joist spacing is 16 inches on center [OC]) for the first ceiling joist. Square mark this point.
- (2) Place a "C" on the side of this point toward the measuring corner of the building.

**Performance Steps**

- (3) Square mark 16-inch intervals, from the 15 1/4-inch mark, to the other end of the building and place a "C" on the side toward the measuring corner.
- (4) Measure and mark 3 1/2 inches from the outside of the corners. This will be used for the nailer when hanging the sheetrock.
- (5) Use the same sequence and square mark the other top plate in the same manner.
- c. Prepare and install the ceiling joists.
  - (1) Square cut the ceiling joists to the required length (according to the prints).
  - (2) Use the framing square to mark off the joist (crown of the joist up) from the heel-cut plumb line to match the slope of the rafters.
  - (3) Follow the same sequence and mark the other end of the joists.
  - (4) Cut both ends of the joists.
  - (5) Install a joist 3 1/2 inches in from each corner of the building.
  - (6) Install the first ceiling joist over the first two "C" marks at each end of the top plates and every "C" mark thereafter.
  - (7) Toenail each end of every joist to the top plate with at least two 16d duplex nails.
3. Determine the rafter-line length.
  - a. Calculate the length of the common rafter. This length is based on the unit of rise and the total run of the roof.
    - (1) Use the framing square method with printed rafter table.
      - (a) Identify the rise and span of the roof from the construction prints.
      - (b) Find the number that reflects the rise along the top of the framing square.
      - (c) Move the rise line down until you find the length of the common rafter-per-foot run line. The number found where the two lines intersect is the unit of rise.
      - (d) Multiply the unit of rise by the total run. Convert the decimal into sixteenths of an inch by multiplying the decimal number by sixteen. If the number to the right of the decimal is greater than 5, round up to the nearest sixteenth. If the number to the right of the decimal is less than 5, round down to the nearest sixteenth (Figure 051-236-1144-3).

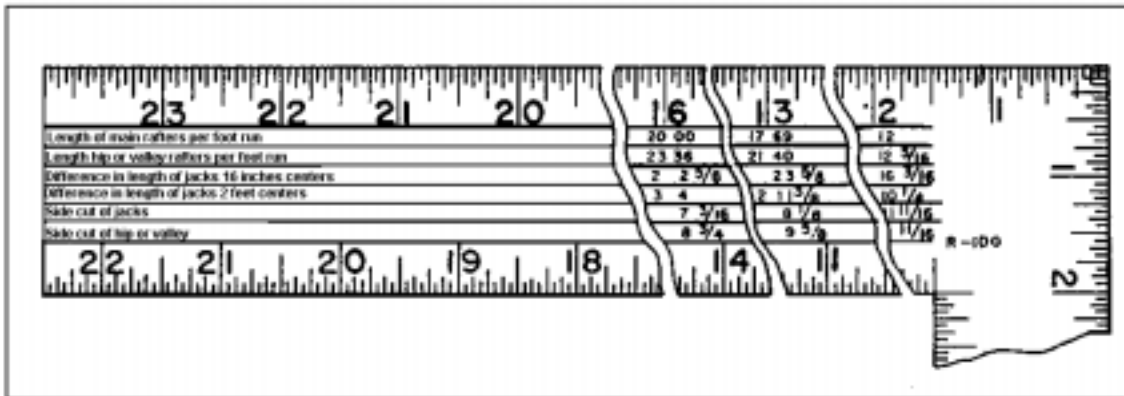

Figure 051-236-1144-3  
Rafter table

NOTE: The total run is equal to half the span of the building.

EXAMPLE: Calculate the common rafter length of a roof with a 7-inch rise and a 16-foot span.

Step 1. Find the number 7 along the top of the framing square. Move down until you find the length of the common rafter-per-foot run line. You should find the number 13.89. This is the unit of rise.

### Performance Steps

Step 2. Multiply the unit of rise by the total run. Convert the decimal into sixteenths of an inch.

8 inches x 13.89 inches = 111.12 inches

.12 inch x 16 inch = 1.92 inches round up to 2/16 inch or 1/8 inch; total rafter length is 111 1/8 inches.

(2) Use the Pythagorean Theorem ( $a^2 + b^2 = c^2$ ). If the framing square is not available, the length of common rafters-per-foot run or bridge measurement can be found by using the Pythagorean Theorem. Here, the unit of rise is the altitude (a), the unit of run is the base (b), and the hypotenuse (c) is the bridge measure.

Two steps remain to complete the procedure.

Step 1. Multiply the number of feet in the total run (8) by the length of the common rafter per foot of run (13.89 inches).  $8 \times 13.89 = 111.12$  inches

Step 2. To change .12 inch to a fraction of an inch, multiply by 16:  $.12 \times 16 = 1.92$

The number to the left of the decimal point represents 1/16 inch. The number .92 to the right of the decimal represents ninety-two hundredths of 1/16 inch. For practical purposes, 1.92 is calculated as being equal to 2 inches x 1/16 inch, or 1/8 inch. As a general rule in this kind of calculation, if the number to the right of the decimal is 5 or more, add 1/16 inch to the figure on the left side of the decimal. The result of steps 1 and 2 is a total common rafter length of 111 1/8 inches or 9 feet 3 1/8 inches.

NOTE: The above methods are different ways to determine the length of the rafter. There is also the stepping-off procedure. Refer to FM 5-426 for the stepping-off method.

- b. Layout the rafters. Once the rafter length is determined, the next step is the layout. Once the rafter length and pitch is determined, place the timber on the sawhorses (saw benches) with the crown or bow (if it has any) as the top side of the rafter (Figure 051-236-1144-4). Use the following steps to layout rafters:



## Performance Steps

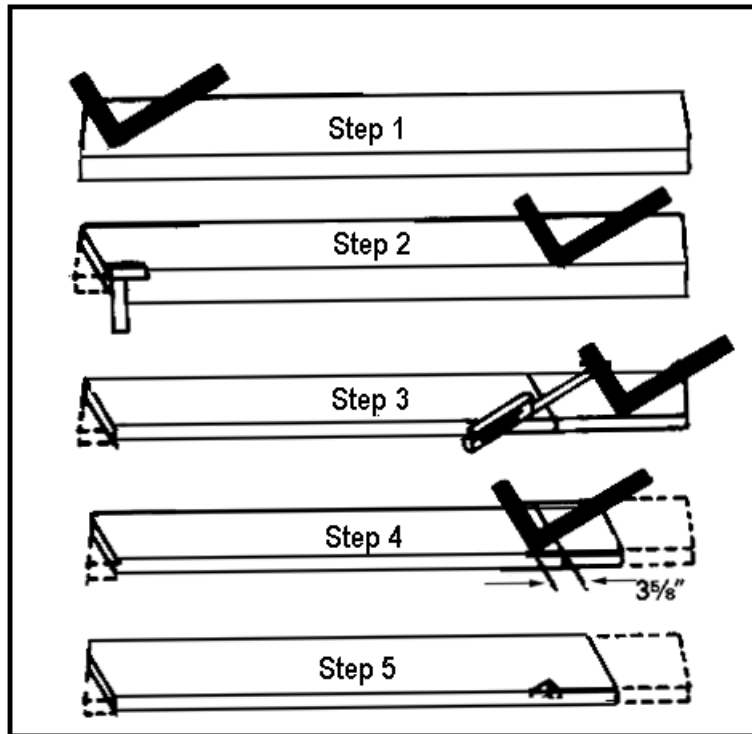

Figure 051-236-1144-4  
Scale or measurement method

Step 1. Determine the rafter length. Find one-half of the horizontal distance (total run) of the rafter. The amount of rise per foot will not be considered yet. (For example, if the building is 20 feet wide, half of the span will be 10 feet (Figure 051-236-1144-1.)

Step 2. After determining the length, lay the timber on the sawhorses (saw benches), with the crown or bow (if it has any) as the topside of the rafter. If possible, select a straight piece for the pattern rafter. If a straight piece is not available, have the crown away from the person laying out the rafter.

Step 3. Hold the square with the tongue in your left hand, the blade in your right, and the heel toward your body. Place the square as near the upper end of the rafter as possible (for example, in Figure 051-236-1144-4 (step 1) the figures 8 on the tongue and 12 on the blade are placed along the timber edge that is to be the top edge of the rafter).

Step 4. Mark along the outside tongue edge of the square, which will be the plumb cut at the ridge.

Step 5. Since the length of the rafter is known to be 12 feet and 1/6 inch, measure the distance from the top of the plumb cut and mark it on the timber. Hold the square in the same manner with the 8 mark on the tongue directly over the 12-foot 1/6-inch mark. Mark along the tongue of the square to give the plumb cut for the seat (Figure 051-236-1144-4, step 2).

Step 6. Measure off, perpendicular to this mark, the length of overhang along the timber. Make a plumb-cut mark in the same way, keeping the square on the same edge of the timber (Figure 051-236-1144-4, step 3). This will be the tail cut of the rafter. Often, the tail cut is made square across the timber.

**Performance Steps**

Step 7. The level cut or width of the seat is the width of the plate measured perpendicular to the plumb cut, as shown in Figure 051-236-1144-4, step 4. Using a try square, square the lines down on the sides from all level and plumb-cut lines. Now the rafter is ready to be cut.

4. Install the ridgeboard.
  - a. Select a straight piece of material.
  - b. Ensure that the length is as long as the roof, plus the overhang required on each end.
  - c. Ensure that both sides are square marked for the amount of the overhang from each end.
  - d. Ensure that both sides are square and marked for the specified center spacing of the rafters (this should match the layout on the top plates).

NOTE: If the ridgeboard is not long enough to span the length of the roof plus the overhang, and joints are necessary, they can be cut so the joint falls on the center of the rafter.

- e. Layout the ridgeboard. Position the ridgeboard over the double top plate and transfer marks.
- f. Assemble the ridgeboard.
  - (1) Set the ridgeboard to its required height (total rise) and hold it in place with temporary vertical props.
  - (2) Nail the rafters to the ridgeboard and the top wall plates.

5. Install the sheathing.
  - a. Check the rafters for plumb. Ensure that there are no badly deformed rafters and check the tail cuts of all the rafters for alignment.
  - b. Place sheathing from the lower edge of the roof up towards the ridge. Start at the same end of the house from which the rafters were laid out.
  - c. Place the top edge on the chalk line. The first sheet of plywood is a full 4- by 8-foot panel.
  - d. Use the cutoff piece of sheathing to start the second course (row of sheathing), provided it spans two or more rafters. If it does not span two rafters, start the second course with a half sheet (4- by 4-foot) of plywood.
  - e. Stagger all the vertical joints.
  - f. Fasten the final course in place. Snap a chalk line at the top edge of the rafters and cut the extra material off.
  - g. Use the same pattern to sheath the opposite side of the roof.

NOTE: Refer to FM 5-426 and NAVEDTRA 12521 for roof coverings and shingles.

**Evaluation Preparation:** Setup: Provide the soldier with the items listed in the conditions. Brief soldier: Tell the soldier to construct a roof system according to FM 5-426. Let the soldier know that the measurements will not exceed +/- 1/8 inch.

<b>Performance Measures</b>	<b>Results</b>	
1. Identified the components of a roof system.	P	F
2. Installed the ceiling joists.	P	F
3. Determined the rafter-line length.	P	F
4. Installed the ridgeboard.	P	F
5. Installed the sheathing.	P	F

**Evaluation Guidance:** Score the soldier GO if all steps are passed (P). Score the soldier NO-GO if any step is failed (F). If the soldier fails any step, show him how to do it correctly.

**References**

**Required**  
FM 5-426

**Related**

**References**  
**Required**  
NAVEDTRA 12521

**Related**

## FABRICATE JOINTS AND SPLICES

051-236-1173

**Conditions:** As a carpentry and masonry specialist in a field environment, given Field Manual (FM) 5-426, construction prints and specifications, a carpenter's tool kit, 2- by 4-inch lumber, nails, shop equipment, goggles, gloves, hearing protection, a hard hat, a pencil, and paper.

**Standards:** Fabricated joints and splices according to FM 5-426. Measurements of the joints and splices were cut to a +/- 1/8 inch and at the correct angle.

### Performance Steps

1. Identify joint fabrication. The five types of joints are the--
  - a. Straight butt. The joint is formed by placing the square-cut end of one board against the square face of another. The butt end of one board should be square and the face of the other board smooth so that they fit perpendicular to each other.
  - b. Oblique butt. The joint is formed by butting the mitered end of one board against the face of another board. Bracing is typically made with this joint and should not be used where great strength is required.
  - c. Miter butt. This joint is formed by bringing the two mitered ends of the boards together to form a desired angle and is normally used at corners (Figure 051-236-1173-1).

Performance Steps

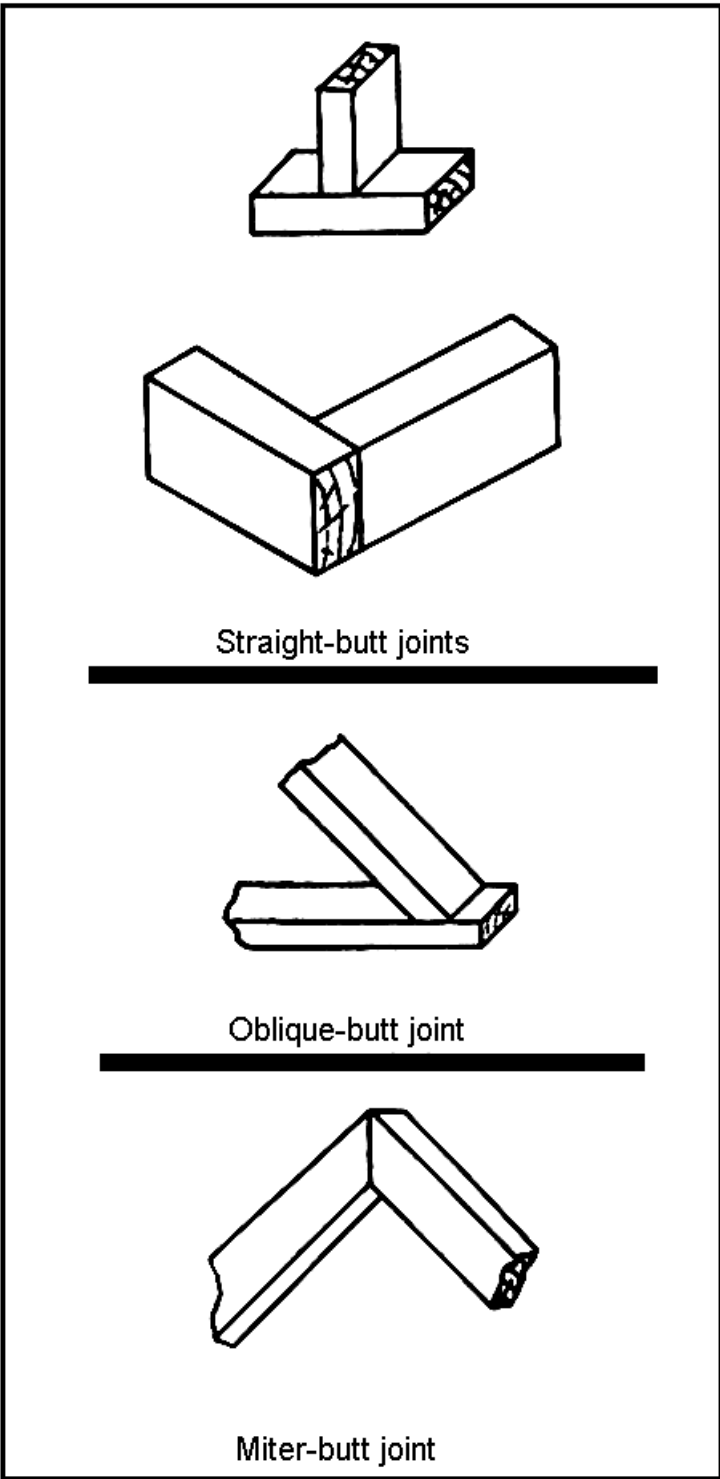

Figure 051-2326-1173-1  
Butt joints

**Performance Steps**

- d. Plain lap. This joint is formed by laying one board over another and fastening the two with screws or nails.
- e. Half lap. This joint is formed by cutting away equal-length portions (usually half) from the thickness of two boards. The two are then joined so they overlap and form a corner (Figure 051-236-1173-2).

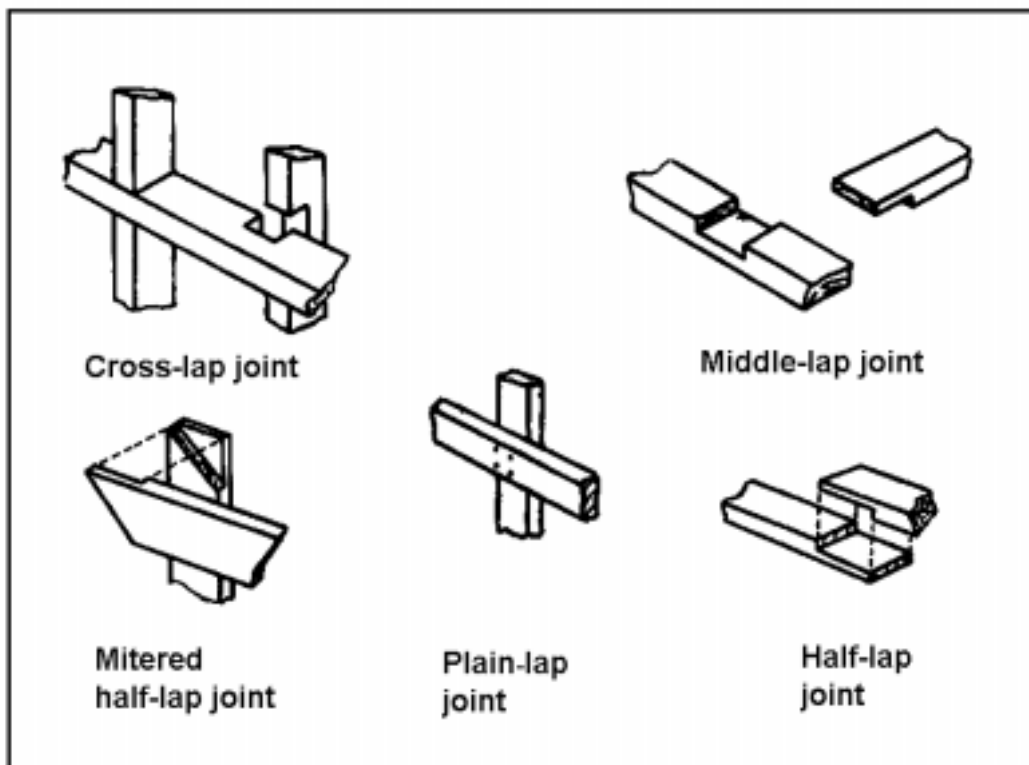

Figure 051-236-1173-2  
Lap joints

2. Identify splices. The four types of splices are--
  - a. Butt. This splice is constructed by butting the squared ends of two pieces of timber together and securing them in this position with two wood or metal pieces fastened on opposite sides of the timber.
  - b. Halved. This splice is made by cutting away half the thickness of equal lengths from the ends of two pieces of timber, then fitting the tongues (laps) together.
  - c. Square. This is a modification of the compression-halved splice. Notches are cut in the tongues or laps to provide an additional locking shoulder.
  - d. Plain. This splice is a hasty substitute for the square splice. A long overlap of two pieces is desirable to provide adequate bearing surface and enough room for fasteners to make up for the lack of shoulder lock.

**Evaluation Preparation:** Setup: Provide the soldier with the items listed in the conditions. Brief soldier: Tell the soldier to fabricate joints and splices according to FM 5-426. Measurements will not exceed +/- 1/8 inch.

**Performance Measures**

**Results**

- |                                  |   |   |
|----------------------------------|---|---|
| 1. Identified joint fabrication. | P | F |
| 2. Identified splices.           | P | F |

**Evaluation Guidance:** Score the soldier a GO if all steps are passed (P). Score the soldier a NO-GO if any of the steps are failed (F). If the soldier fails any step, show him how to do it correctly.

**References**

- Required**  
FM 5-426  
TM 9-243

**Related**

## INSTALL EXTERIOR FINISH

051-236-1201

**Conditions:** As a carpentry and masonry specialist in a field environment, given Field Manual (FM) 5-426, construction prints and specifications, a completed wood structure without exterior finish, 1- by 4-inch lumber, lap siding, nails, a carpenter's tool kit, a circular saw, saw horses, an extension ladder, a stepladder, a staple gun, goggles, gloves, hearing protection, a hard hat, paper, and a pencil.

**Standards:** Installed the exterior finish according to FM 5-426 and the construction prints and drawings. Measurements did not exceed +/- 1/8 inch.

### Performance Steps

NOTE: In order to install the exterior finish, you must identify the types and components of the exterior wall coverings and finishes.

1. Identify the following types and components of exterior wall coverings (refer to FM 5-426):
  - a. Sheathing.

- (1) Sheathing uses.

- (a) Provides a foundation for nailing the finished siding and in some instances, provides some insulation value.
      - (b) Nails directly to the frame.

NOTE: Refer to FM 5-426, Figure 6-41.

- (2) Sheathing types.

- (a) Wood (dimensional boards). Use 1 inch thick by 6, 8, 10, or 12 inches wide and is made of number 1 common square or matched-edge material.
      - (b) Gypsum board. Gypsum board is 1/2 inch thick by 2 feet or 4 feet wide by 8 feet long.
      - (c) Fiberboard. Fiberboard is 25/32 inches thick by 2 or 4 feet wide and 8, 9, 10, or 12 feet long.
      - (d) Plywood. Plywood is 1/4, 3/8, 1/2, or 5/8-inch thick by 4 feet wide and 8, 9, 10, or 12 feet long.
      - (e) Building paper.

- (3) Sheathing installation procedures.

- (a) Wood (dimensional boards). Select the lengths economically. Use two 8d nails to nail sheathing boards 6 inches to 8 inches wide to each stud crossing. Nail wider boards with at least three 8d nails at each stud crossing. All board-end joints are made at the center of the stud. Apply board sheathing horizontally or diagonally. Horizontal placement ensures less waste of material; however, if the sheathing is applied in this manner, some type of corner bracing is required. Board sheathing applied diagonally is slightly more difficult to install. The sheathing applied at a 45-degree angle adds strength to the wall and eliminates the need for diagonal corner bracing. Apply wood sheathing starting at the foundation or bottom and working upward or toward the top of the wall. Butt each board tightly against the next and stagger the joints that fall on the intermediate studs so no adjoining board has a break or joint at the same location (Figure 051-236-1201-1).



## Performance Steps

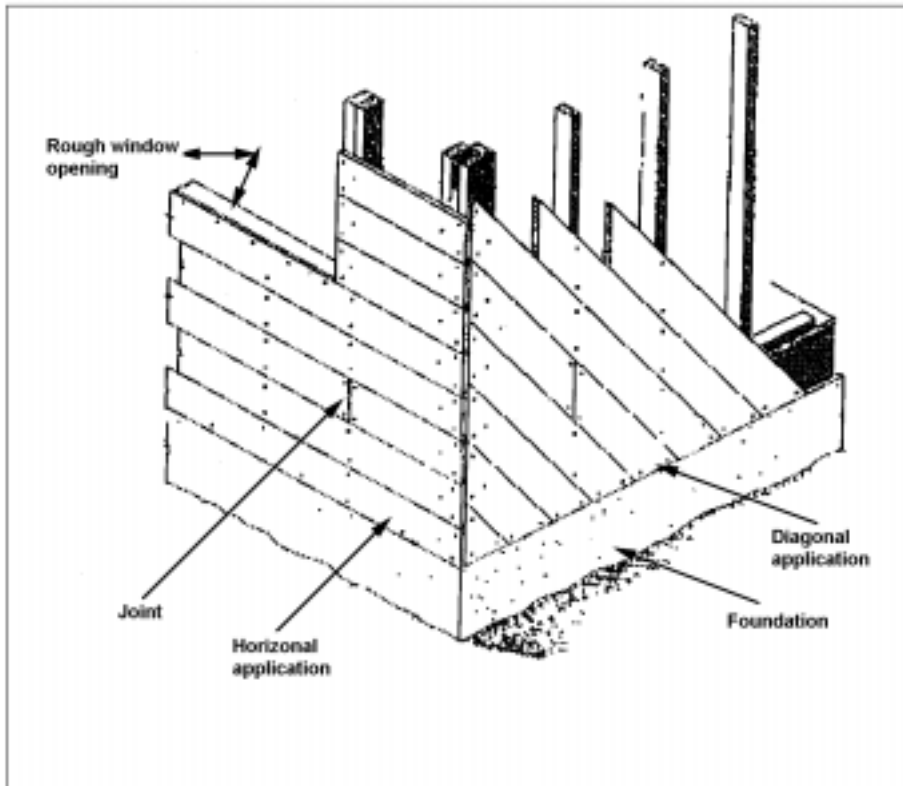

Figure 051-236-1201-1  
Wood sheathing installation

- (b) Gypsum board sheathing. Use gypsum board when the finish siding will be made of wood siding such as wood stakes. Use 1 3/4- or 2-inch galvanized roofing nails to fasten the gypsum board to the studs. Apply gypsum board sheathing horizontally with the vertical joists staggered between the sheets. Space the nails 7 inches apart when nailing the finished siding through the sheathing into the studs. Otherwise, space them 3 1/2 inches apart.
- (c) Fiberboard sheathing. Apply fiberboard horizontally with the vertical joints staggered between the sheets. Nail sheathing to all the studs with 2-inch galvanized roofing nails. Set the nails back 3/8 inch from the edge of the sheet. Nail spacing should be 3 inches on center along the edges and 6 inches on center at the intermediate members. Apply 4- by 8-foot sheets vertically. This allows for the entire perimeter edge to be nailed without adding nailing strips. However, sheathing may be applied horizontally as required. Apply sheets with a 1/8-inch space to allow for expansion.
- (d) Plywood. Plywood is one of the most highly recommended sheathing materials for walls. Omit corner braces when plywood is used for sheathing. The minimum thickness of plywood should be 1/4 inch when the studs are spaced at 16 inches on center and 3/8 inch when the studs are spaced 24 inches on center. Apply plywood in 4- by 8-foot sheets vertically. This allows for the entire perimeter edge to be nailed without adding nailing strips. However, it may be applied horizontally as required. Use 6d common nails when the plywood sheathing thickness is 1/4, 3/8, or 1/2 inch. The nail spacing should be 6 inches on center along the edges and 12 inches on center at the intermediate members.

### Performance Steps

- b. Building paper. Refer to FM 5-426.
  - (1) Use to prevent air from penetrating through the exterior walls.
  - (2) Use whenever wood sheathing is applied.
  - (3) Apply horizontally starting at the bottom of the wall. Apply the paper smoothly. Overlap the joints about 4 inches.
  - (4) Use roofing nails to fasten the paper. Space the nails at intervals sufficient to hold the paper in place.
2. Identify the following types and components of exterior finishes:
  - a. Siding.
    - (1) Siding is usually installed over some type of panel sheathing and building paper (if required). However, in mild climates, it may be installed directly over the studs.
    - (2) When installed over solid sheathing, the siding may be nailed directly to the sheathing and the end joints may fall between the framing members (studs).
  - b. Horizontal siding. Horizontal siding is constructed of horizontal overlapping strips of wood, aluminum, or vinyl. Common types of horizontal siding include--
    - (1) Aluminum and vinyl. Aluminum and vinyl are designed to provide an appearance of painted wood siding. This type of siding is durable, lightweight, and is low maintenance.
    - (2) Clapboard. Clapboard is made of lumber with no bevels or grooves. It is installed in an overlapping configuration or with battens.
    - (3) Beveled. Beveled siding is manufactured with a tin-top edge and a thick edge at the butt. This type of siding comes in varying widths and is nailed at the butt edge and along the top of the beveled edge. Window and door casings are framed first and the beveled siding is butted against the casings. Corners may be mitered or vertical corner boards may be applied. The siding is then fitted against the edges of the corner boards.
    - (4) Drop siding. Drop siding is used as sheathing and finish siding (in a single application) or in combination with separate sheathing. It is manufactured in a wide variety of architectural face designs and may be shiplapped or tongue and grooved. It is used as both sheathing and finish siding. It is nailed directly into the studs with the tongue at the top. Door and window casings are applied after the siding is applied. When normal types of sheathing are applied, the window and door casings are placed before installing the drop siding. The drop siding will butt against the casings.
3. Identify the corner coverings.
  - a. Outside corners (wood siding.) Corner boards usually consist of two pieces of stock: one piece 3 inches wide and the other 4 inches wide if an edge-butt joint between the corner boards is used. Corner boards are placed vertically on the corners with the siding butting to them.
  - b. Inside corners (wood siding) (Figure 051-236-1201-2).
    - (1) Nailing strips are square strips fastened to the inside corner with the siding butting to them.

## Performance Steps

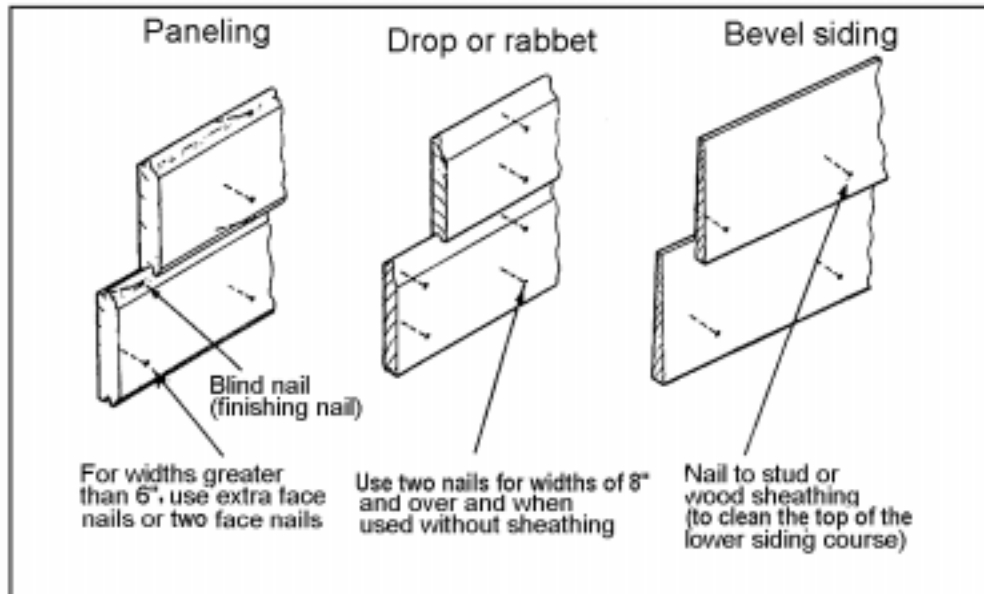

Figure 051-236-1201-2  
Nailing the siding

- (2) Mitered corners are not always satisfactory, unless they are done carefully to prevent openings.
4. Install an exterior finish.
- Apply the sheathing.
  - Apply felt paper (vapor barrier).
    - Cut an 8-foot length of paper.
    - Align the felt paper vertically along the plywood sheathing at the corner, leaving a 6-inch overhang at the corner to fold around and allow overlap at the corners.
    - Staple the felt paper to the plywood at about 2-foot intervals vertically and 12 to 16 inches on center horizontally.
  - Install the ledger board or starter strip. Nail the board strip flush along the bottom of the sheathing with 8d finish nails spaced about 12 inches on center.
- NOTE: The board or strip should be level.
- Install the siding.
    - Cut the siding to length (length between the corner boards).
    - Start from the bottom of the ledger board, measure, mark, and snap chalklines at 8 1/2-inch intervals (guidelines).
    - Install the first course. Nail the board with the upper edge of the board flush with the first guideline, placing nails 1/2 inch down from the topside, spaced about 8 inches on center.
    - Use the chalked guidelines to install the remaining courses.
  - Install the corner boards.
    - Cut the corner board material 8 feet in length.
    - Install flush along the outside of the building corner with 16d finish nails spaced about 12 to 18 inches on center (Figure 051-236-1201-3).

**Performance Steps**

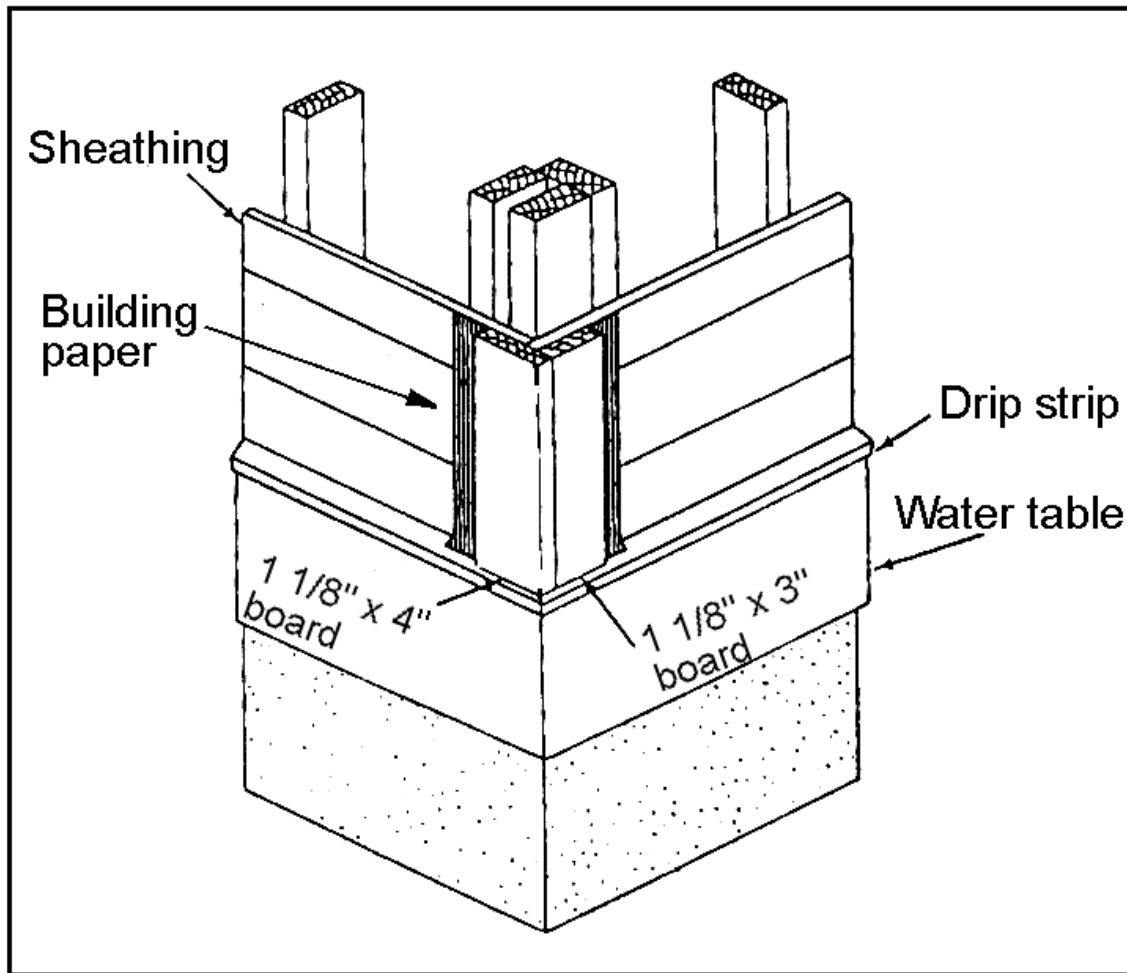

Figure 051-236-1201-3  
Corner board

**SCENARIO:** You have been tasked to install an exterior finish on a wood frame structure. You will install plywood sheathing, number 15 felt paper, 1- by 8-inch lumber for bevel, siding, and 1-inch material for corner boards.

**NOTE:** When training at the unit, sheathing, siding, and corner boards can be substituted to fit the needs of the mission.

**Evaluation Preparation:** Setup: Provide the soldier with the items in the conditions. Brief soldier: Tell the soldier to install exterior finish according to FM 5-426 and the construction prints and drawings. Measurements will not exceed +/- 1/8 inch.

**Performance Measures**

1. Identified the types and components of exterior wall coverings.

**Results**

P F

**Performance Measures**

2. Identified the types and components of exterior finishes.
3. Identified the corner coverings.
4. Installed an exterior finish.

**Results**

P	F
P	F
P	F

**Evaluation Guidance:** Score the soldier a GO if all steps are passed (P). Score the soldier a NO-GO if any step is failed (F). If a soldier fails any step, show him how to do it correctly.

**References****Required**

FM 5-412

FM 5-426

**Related**

## CONSTRUCT A WALL SYSTEM

051-236-1203

**Conditions:** As a carpentry and masonry specialist in a field environment, given Field Manual (FM) 5-426, construction prints and specifications, a carpenter's tool kit, a completed floor system, plywood, 2- by 4-inch lumber, nails, a circular saw, an extension cord, a power source, sawhorses, a ladder, safety goggles, gloves, hearing protection, a hard hat, paper, and a pencil.

**Standards:** Constructed a wall system according to FM 5-426 and the construction prints and drawings. Measurements did not exceed +/- 1/8 inch.

### Performance Steps

NOTE: In order to construct a wall system, you must identify the components of a wall system, calculate the component lengths, and then install the wall system components.

1. Identify the following wall-framing types:
  - a. Walls. The wall system of a wood-framed building consists of exterior and interior walls.
  - b. Partitions. Partitions are usually classified as inside walls. The two major types of partitions are--
    - (1) Bearing. Bearing partitions support the ends of the floor joists or ceiling joists.
    - (2) Nonbearing. Nonbearing partitions run in the same direction as the joists and carry very little weight from the structures above.
2. Identify the following wall-system components (Figure 051-236-1203-1):

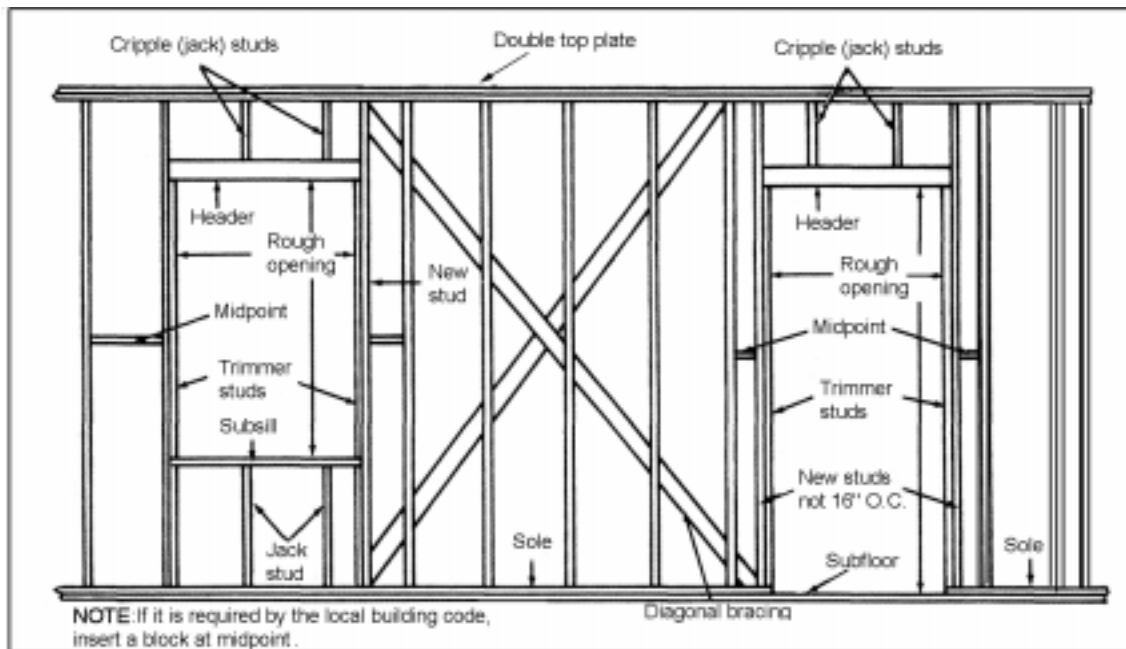

Figure 051-236-1203-1  
Wall-system components

- a. Sole plate. Sole plates support and carry the bottom end of the studs. The sole plate is nailed to the subfloor.
- b. Studs. The vertical members of wooden forms or frames.
- c. Top plates.

### Performance Steps

(1) Single. Ties the studding together at the top and serves as a link between the roof and the wall.

(2) Double. Ties walls and partitions together.

d. Corner posts. These are constructed wherever a wall ties into another wall.

NOTE: Refer to FM 5-426, Figures 6-30 through 6-34.

e. T-posts. A stud wide enough to extend beyond the partition, constructed to provide a nailing surface for the inside wall finish and a means of tying in the intersecting wall.

f. Header. Placed on top of a rough opening. It must be strong enough to carry the weight bearing down on that section of wall.

g. Cripple studs. Nailed between the header and the double top plate of a door or window opening.

h. Trimmer. Short studs the size of a vertical opening, that are cut and nailed to the inside face of the outside studs.

i. Bracing. Used to stiffen framed construction and make it rigid (Figure 051-236-1203-2). The three methods of bracing include let-in bracing, cut-in bracing, and diagonal sheathing.

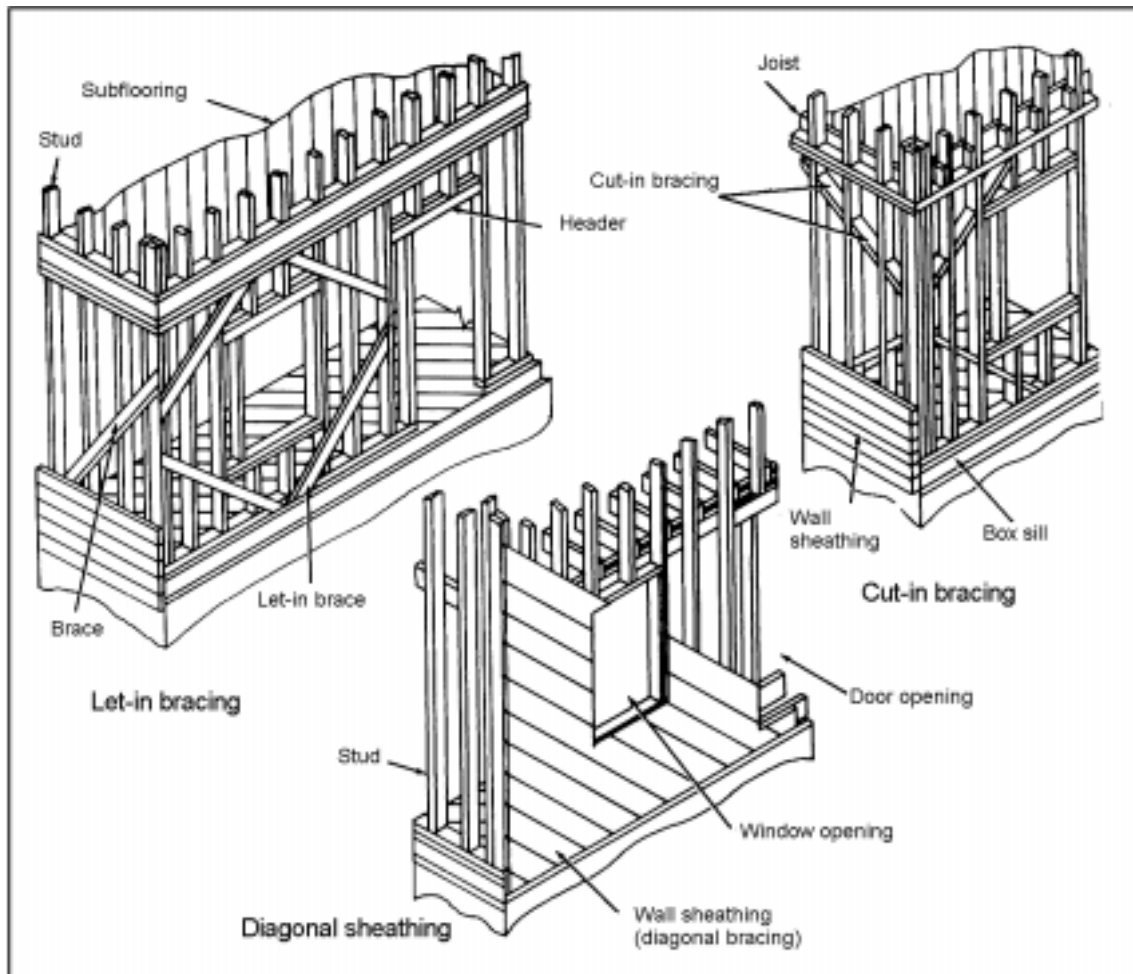

Figure 051-236-1203-2  
Methods of bracing

j. Bridging. Also known as fire stops or fire blocks. They are cut and positioned in between the studs to help stiffen and straighten the wall and act as a baffle that retards fire travel inside the walls. Most local building codes require fire stops in walls over 8 feet 1 inch high.

**Performance Steps**

3. Calculate component lengths for a floor system.
  - a. Determine wall dimensions. The wall framing plan will specify the stud size, the spacing between the studs, and the door and window size and location.

NOTE: Refer to Technical Manual (TM) 5-704.

- b. Calculate component lengths.

- (1) Common stud length.

FORMULA: Finished wall height - combined top and sole plate thickness

- (a) Finished wall height = 8 feet
- (b) Combined top, double top, and sole plate thickness = 4 1/2 inches
- (c) Common stud length = 8 feet - 4 1/2 inches = 7 feet 8 1/2 inches

- (2) Header length.

FORMULA: Header length = finished door or window width + framing allowance + combined trimmer thickness

- (a) Both door and window width = 3 foot
- (b) Framing allowance = 2 1/2 inches
- (c) Combined trimmer thickness = 3 inches
- (d) Header length = 3 foot + 2 1/2 inches + 3 inches = 3 foot 5 1/2 inches

- (3) Trimmer stud length.

FORMULA: Trimmer stud length (doors) = (finished door height + framing allowance) - sole plate thickness

- (a) Finished door height = 6 feet 8 inches
- (b) Framing allowance = 2 1/2 inches
- (c) Sole plate thickness = 1 1/2 inches
- (d) Trimmer stud length = (6 feet 8 inches + 2 1/2 inches) - 1 1/2 inches = 6 feet 9 inches - 1 1/2 inches = 6 feet 7 1/2 inches

FORMULA: Windowsill length = finished sill length + framing allowance

Finished sill length = 3 feet

Framing allowance = 2 1/2 inches

Windowsill length = 3 feet + 2 1/2 inches = 3 feet 2 1/2 inches

- (4) Rough windowsill length.

FORMULA: Finished sill length + framing allowance

- (a) Finished sill length = 3 feet 6 inches
- (b) Framing allowance = 0 inches
- (c) Windowsill length = 3 feet 6 inches + 0 inches = 3 feet 6 inches

- (5) Cripple stud length.

NOTE: Wait until the wall is assembled to measure and cut the cripple studs.

- (a) Upper cripple studs. Measure the distance from the bottom of the top plate to the top of the header (doors or windows) after the wall is assembled.
- (b) Lower cripple studs. Measure the distance from the top of the soleplate to the bottom of the rough windowsill after the wall is assembled.

4. Install wall-system components. Lay out the sole plate and the top plate.

- a. Measure, mark, and square cut the sole plate and top plate to size.
- b. Lay out the plates for all openings (window and door).

- (1) Align the sole plate and top plate side by side.
- (2) Complete layout from left to right.

NOTE: All measurements must be made from the left end of the plates.

- (3) Refer to the drawings for the centerline (CL) locations of all openings.
- (4) Lay out these centerlines on the plates.

- (a) Measure the distances from the left end of the plates and square mark these points on both plates.



**Performance Steps**

- (b) Mark the CL on these lines to distinguish them from other types of marks you will lay out on the plates (mark window centerline (WCL) for windows and door centerline (DCL) for doors).
  - (5) Refer to the drawings for the width of all openings in the wall.
  - (6) Add to each specified width, the required framing allowance to determine the width of the rough opening.
  - (7) Divide the rough opening width in half.
  - (8) Measure this half width from both sides of the CL.
  - c. Lay out the plates for the trimmer studs.
    - (1) Square mark 1 1/2 inches outside both rough opening marks.
    - (2) Mark a "T" in these two 1 1/2 inch spaces for trimmer studs.
    - (3) Mark an "X" outside each trimmer stud to show the locations of the common studs.
  - d. Lay out the plates for the corner posts, common studs, and cripple studs.
    - (1) Lay out the corner posts.
      - (a) Outside corner post. Measure in 1 1/2 inches from the outside corner of each plate. Square mark these points and mark an "X" for the common studs. Measure in 3 inches from the outside corner of each plate. Square mark these points. Mark a "B" to indicate filler block on the inside space and mark an "X" for the common stud outside each filler block space.
      - (b) Inside corner posts and partition posts. From the outside corner, measure and mark the distance to the intersecting wall. Square mark and place an "X" for common studs toward the measuring corner. Measure and mark 3 1/2 inches from the square mark. Square mark and place an "X" for common studs away from the measuring corner. Square mark 1 1/2 inches from the plate edge that will be facing inside, once erected. Place a "B" for filler block in this space.
    - (2) Lay out the common and the cripple studs.
      - (a) Measure 15 1/4 inches from the outside corner of each plate.
      - (b) Square mark these points.
      - (c) Place an "X" alongside this mark on the side away from the measuring corner.
      - (d) From the 15 1/4-inch mark, measure and mark every 16 inches to the end of each plate.
      - (e) Square mark these points.
      - (f) Within all rough openings, place a "C" to indicate cripple studs.
- NOTE: Place the mark on the side of the line away from the measuring corner and on the same side as the first stud.
- (g) Place an "X" for common studs alongside the remaining lines.
  - (h) Place an "X" at the end of each plate to indicate the end studs.

## 5. Cut and assemble framing members.

- a. Measure, mark, and square cut the required number of common studs to length.
- b. Prepare the corner posts.
  - (1) Cut three pieces of 2- by 4-inch lumber 12 inches long.
  - (2) Place the lumber at the top, middle, and bottom positions flush between the common studs.
  - (3) Nail together with 16d duplex nails, driving the nails through the studs into the filler blocks.
- c. Prepare and assemble rough door openings.
  - (1) Measure, mark, and square cut the door trimmers to length.
  - (2) Install the door trimmers.
  - (3) Measure, mark, and cut the required number of pieces for the header.
  - (4) Install the door header by placing the header on top of the trimmer studs and between the king studs, then nail with 16d duplex nails.
- d. Prepare and assemble the rough window opening.
  - (1) Measure, mark, and square cut the trimmers to length.
  - (2) Construct the window header and subsill (refer to wall drawings).
  - (3) Install the window trimmer studs, subsill, and header

### Performance Steps

- (a) Measure down the trimmer stud the height of the window rough opening.
  - (b) Nail the rough window sill below the mark with 16d common nails.
  - (c) Nail the trimmer studs flush with the king stud using 16d common nails.
  - (d) Place the header on top of the trimmer studs between the king studs and nail it in place with 16d duplex nails.
  - e. Prepare and nail the common studs, corner posts, and preassembled rough opening unit to the sole plate and top plate.
    - (1) Place the sole and top plates on a flat surface, approximately 8 feet apart, with the markings on both plates facing each other.
    - (2) Place the corner posts, common studs, and rough opening assembly between the plates according to the plate layout.
    - (3) Align the corner posts, common studs, and rough opening assembly ends along the squared lines (over the "Xs").
    - (4) Nail two 16d common nails through the top and sole plates, into each end of every stud approximately 3/4 inch from the edges of the plates.
  - f. Construct and install cripple studs.
  - g. Construct and install the fire blocks.
    - (1) Mark the studs for the fire block.
      - (a) Measure down 48 inches from the top of the double top plate at both ends of the wall and mark.
      - (b) Snap a chalk line through these points.
    - (2) Prepare and secure the fire blocks.
      - (a) Square cut the fire blocks to the measurements of the spaces between the studs at the sole plate.
      - (b) Nail the fire blocks alternately, offsetting them above and below the chalk marks on the studs.
  - h. Square the wall and place the braces.
    - (1) Place the completed framed wall on the subfloor.
    - (2) Measure the diagonal distance; once equal the wall is square.
    - (3) Place the braces on the squared wall (let-in diagonal, plywood, or other exterior covering).
6. Install the wall sections and the double top plates.
- a. Plan the sequence for raising the wall sections. The sequence should ensure that each raised wall supports the next section.
  - b. Raise the first wall section.
    - (1) Use two people to raise the first section, one on each side; one person nails the section.
    - (2) Raise the wall into position, flush along the edge of the subfloor.
    - (3) Secure the walls with 16d duplex nails.
    - (4) Hold the wall in position, plumb, and temporarily brace it.
  - c. Raise the remaining wall sections in the same manner as the first one and nail the corners together.
  - d. Secure the plywood bracing (sheathing).
    - (1) Nail the remaining edges of the plywood.
    - (2) Remove the temporary bracing after all the plywood bracing has been secured.
  - e. Install the partition walls (refer to the blueprints).
  - f. Install the upper top plate.
    - (1) Cut and install the upper top plate of the partition wall from the outside edge of the exterior wall to the end of the partition wall.
    - (2) Cut and install the remaining upper top plates, ensuring that the corners overlap.

**Evaluation Preparation:** Setup: Provide the soldier with the items listed in the conditions. Brief soldier: Tell the soldier to construct a wall system according to FM 5-426 and using the construction prints and drawings. The measurements will not exceed +/- 1/8 inch.

**Performance Measures**

**Results**

1. Identified wall-framing types.	P	F
2. Identified wall-system components.	P	F
3. Calculated component lengths for a floor system.	P	F
4. Installed wall-system components.	P	F
5. Cut and assembled framing members.	P	F
6. Installed the wall sections and the double top plates.	P	F

**Evaluation Guidance:** Score the soldier a GO if all steps are passed (P). Score the soldier NO-GO if any step is failed (F). If the soldier fails and step, show him how to do it correctly.

**References**

**Required**  
 FM 5-412  
 FM 5-426

**Related**

Subject Area 9: Finish Carpentry

**APPLY INTERIOR TRIM**

**051-236-1174**

**Conditions:** As a carpentry and masonry specialist in a field environment, given Field Manual (FM) 5-426, a measuring tape, a combination square, a miter box (power), a coping saw, a claw hammer, a pencil, a nail set, baseboard stock, and 6d and 8d finish nails.

**Standards:** Applied the interior trim (baseboard with an outside miter, an inside miter, and coped and scarf joints) according to FM 5-426. Ensured that all the nails were set and without hammer marks on the finished surface.

**Performance Steps**

1. Identify interior trim. Interior trim is the finishing touch for doors, windows, cabinets and walls (at both the floor and ceiling levels on the walls) which is achieved by installing molding. Interior trim includes--
  - a. Trim members are easy to install, stain, or paint and have a pleasing appearance. They are available in a variety of shapes, sizes, and types of wood, such as birch, oak, walnut, mahogany, pine, and fir.
  - b. Casing. Casing is the trim around the doors and windows, which provides a finished surface between the wall covering and the jamb.
    - (1) Casing of the same type should be used around both doors and windows.
    - (2) Casing is nailed to the jamb leaving a 3/16- to 1/4-inch edge distance, which is called a "reveal." Casing is also nailed to the frame.
    - (3) Types of joints for casing installation.
      - (a) Miter. The miter joint should be used at the outside corners.
      - (b) Butt. The butt joint should be used for the inside corners and at the floor.
  - c. Baseboard. Baseboard is the trim which provides the finish between the finished wall and the floor.
    - (1) Baseboard is the last trim member to be installed so it can be fitted tight against the casings and/or cabinets.
    - (2) Baseboard is available in several widths and forms.
      - (a) One-piece base varies from 7/16 inch thick by 2 1/4 inches wide to 1/2-inch thick by 3 1/4 inches wide (or wider).
      - (b) Two-piece base is commonly 5/8 inch thick by 3 1/4 inches wide (or wider) with a 1/2- by 3/4-inch base shoe.
      - (c) Three-piece base is a two-piece base with a base cap.
    - (3) Joint types used for installation (Figure 051-236-1174-1) include--
      - (a) Butt. Butt joints are used at the inside corners.
      - (b) Miter. Miter joints are used for the outside corners.
      - (c) Cope. Cope joints are used for the inside corners.
      - (d) Scarf (blind miter). This joint is used to join long stretches of molding.

## Performance Steps

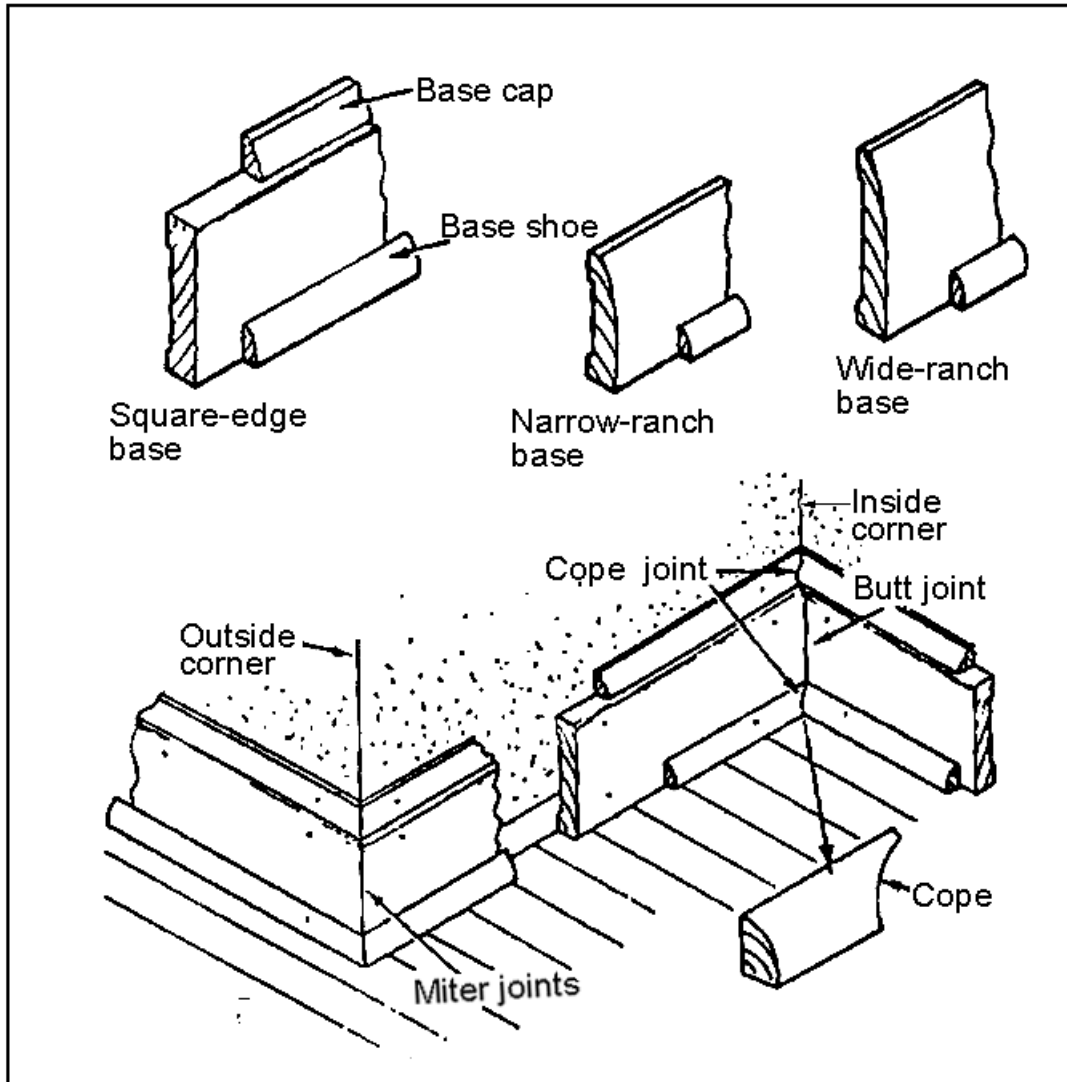

Figure 051-236-1174-1  
Base moldings

- d. Ceiling molding. Ceiling molding is the trim used at the junction of the wall and the ceiling for architectural effect or to terminate drywall or wood paneling (Figure 051-136-1174-2).
- (1) Ceiling molding is available in crown, cove, or rectangular shapes and in a variety of sizes.
  - (2) Joint types used for ceiling molding installation include--
    - (a) Miter. The miter joint is used at the inside and outside corners.
    - (b) Cope. Cope joints are used for the inside corners (Figure 051-236-1174-2).
    - (c) Scarf (blind miter). This joint is used to join stretches of molding.

**Performance Steps**

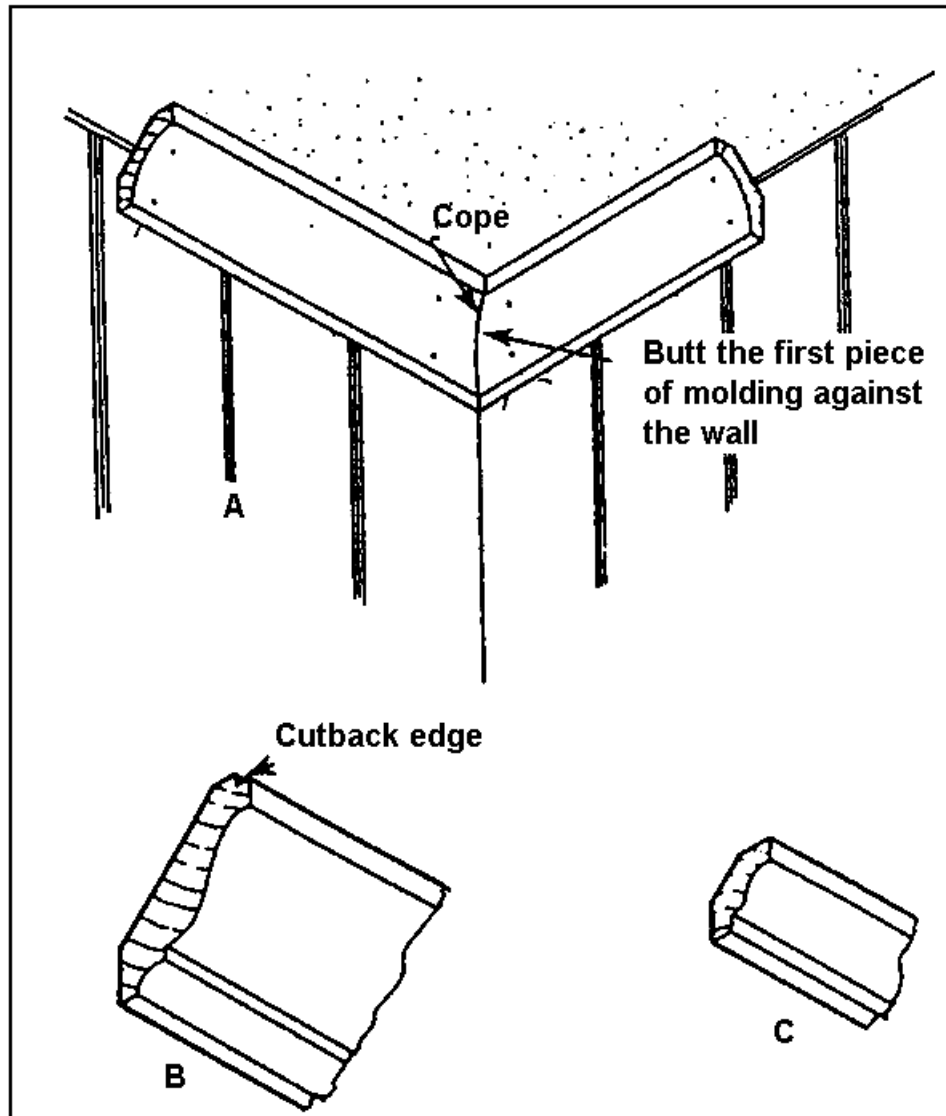

Figure 051-236-1174-2  
Ceiling moldings

2. Install trim around a door.
  - a. Measure, mark, and cut a piece of baseboard, for walls that contain a door, with an inside miter at one end and a butt for the corner near the door running to the door casing. Secure it with 6d or 8d finish nails.
  - b. Measure, mark, and cut a piece of baseboard, with each end having a butt joint to run from the door casing to the inside corner of the partition wall. Secure with 6d or 8d finish nails.
  - c. Measure, mark, and cut a piece of baseboard with a coped joint at the inside corner of the partition wall and an outside miter at the other end of the baseboard for the outside corner of the partition wall. Secure with 6d or 8d finish nails.
  - d. Measure, mark, and cut a piece of baseboard with an outside miter for the end of the partition wall. Secure with 6d or 8d finish nails.

**Performance Steps**

- e. Measure, mark, and cut a piece of baseboard with an outside miter at one end and an inside miter at the other to run along other side of partition wall. Secure with 6d or 8d finish nails.
- f. Measure about halfway down the back wall between the partition wall and corner and place an inside miter at both ends. Secure with 6d or 8d finish nails.
- g. Measure from the outside edge of the inside miter joint to the corner. Cut an outside miter for the center of the wall to overlap the previous cut piece to form a scarf joint and place an inside miter at the other end to be placed in the corner. Secure with 6d or 8d finish nails.
- h. Set all the nails with a nail set.

3. Install trim around a window.

- a. Measure, mark, and cut a piece of baseboard with an inside miter at one end and a butt for the corner near the window running to the corner of the partition wall. Secure with 6d or 8d finish nails.
- b. Measure, mark, and cut a piece of baseboard with a coped joint at the inside corner of the partition wall and an outside miter at the other end of the baseboard for the outside corner of the partition wall. Secure with 6d or 8d finish nails.
- c. Measure, mark, and cut a piece of baseboard with an outside miter for the end of the partition wall. Secure with 6d or 8d finish nails.
- d. Measure, mark, and cut a piece of baseboard with an outside miter at one end and an inside miter at the other to run along other side of the partition wall. Secure with 6d or 8d finish nails.
- e. Measure about halfway down the back wall between the partition wall and corner and place an inside miter at both ends. Secure with 6d or 8d finish nails.
- f. Measure from the outside edge of the inside miter joint to the corner. Cut an outside miter for the center of the wall to overlap the previous cut piece to form a scarf joint and place an inside miter at the other end to be placed in the corner. Secure with 6d or 8d finish nails.
- g. Set all the nails with a nail set.

SCENARIO: Apply interior trim to a project to include installing baseboard with an outside miter, an inside miter, and coped and scarf joints.

**Evaluation Preparation:** Setup: Provide the soldier with the items listed in the conditions. Brief soldier: Tell the soldier to apply interior trim to include baseboard with outside miter, inside miter, coped and scarf joints according to FM 5-426. Ensure that all nails are set with no hammer marks on the finished surface.

<b>Performance Measures</b>	<b>Results</b>	
1. Identified interior trim.	P	F
2. Installed trim around a door.	P	F
3. Installed trim around a window.	P	F

**Evaluation Guidance:** Score the soldier GO if all steps are passed (P). Score the soldier NO-GO if any step is failed (F). If the soldier fails any steps, show him how to do it correctly.

**References**

**Required**  
 FM 5-412  
 FM 5-426

**Related**

## INSTALL SHEETROCK (DRYWALL)

051-236-1177

**Conditions:** As a carpentry and masonry specialist on a training site, given an unfinished wall and ceiling unit, a 16-foot measuring tape, a drywall hammer, a 4-inch T-square, a hand level, a 4-inch utility knife, a key hole saw, a chalk line, a foot lift, a corner-bead crimper, a rubber mallet, a drywall saw, sawhorses, a stepladder, 1/2-inch by 4- by 8-foot gypsum sheetrock, sheetrock nails, a corner bead, 4-, 6-, 8-, 10-, and 12-inch drywall knives, a hammer, drywall sponge, a mud pan, an inside corner tool, a corner tape creaser, a stepladder, a potato masher, a bucket with water, wallboard tape, joint compound (ready mix), Field Manual (FM) 5-426, Naval Education Training Command (NAVEDTRA) 12521 Builder 3 & 2, Volume 2.

**Standards:** Installed sheetrock correctly with the correct spacing of nails and screws according to FM 5-426. The sheetrock joints were filled, taped, and smoothed ready for painting, with holes properly repaired.

### Performance Steps

1. Hang sheetrock.
  - a. Attach the sheetrock to the ceiling first.
    - (1) Measure the distance from the inside edge of the top plate to the outside edge of the second ceiling joist.
    - (2) Measure and cut a piece of sheetrock 48 inches long and to the width of the measured ceiling.
    - (3) Attach the sheetrock to the ceiling with sheetrock nails (space 5 to 7 inches on center).
  - b. Attach the sheetrock to the wall.
    - (1) Locate a section where the studs are 8 feet apart on center and where a full sheet of sheetrock can be laid horizontally.
    - (2) Check the layout to ensure that no joints are above or below the door or window openings.
    - (3) Attach all the sheetrock from the ceiling down to the floor, placing the first sheet in position so that the edge falls on the center of the stud.
    - (4) Place the sheetrock snugly against the ceiling. Use a hand level to ensure that it is level.
    - (5) Secure the sheetrock with nails 6 inches to 8 inches on center and 3/8 inch from the edge.
    - (6) Attach succeeding sheets on the top half of the wall against the attached sheets. Ensure that the joints fall center on the studs and proper nail spacing is maintained.
    - (7) Use a utility knife or sheetrock saw to cut the opening for the doors and windows (Figure 051-236-1177-1).



Performance Steps

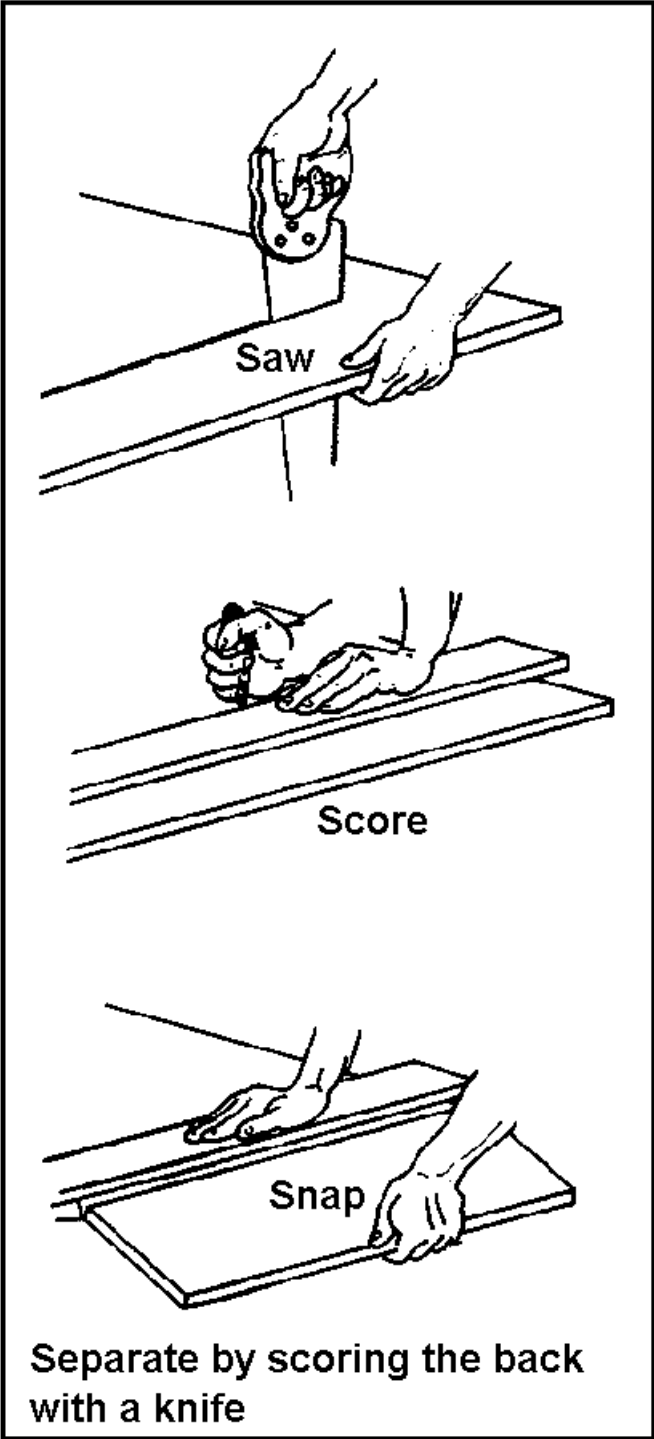

Figure 051-236-1177-1  
Cutting sheetrock

c. Lay out the receptacles.

**Performance Steps**

- (1) Measure the distances from the inside to inside corner to both sides of the box and record them.
  - (2) Measure the distances from the installed sheetrock to the top and bottom of the receptacle box and record them.
  - (3) Measure and mark the cut-out area allowing 1/16-inch clearance around the sheetrock.
  - d. Cut out the receptacle opening. Use a utility knife to drive a hole in the opening. Use a keyhole saw to cut the sheetrock, using a slight undercut bevel so the back is larger than the front.
  - e. Attach the prepared sheetrock around the receptacles.
    - (1) Place the sheetrock in position and ensure that the receptacle fits without breaking the paper.
    - (2) Adjust the opening, if necessary, and secure the sheet to the studs with sheetrock nails.
    - (3) Use a surform to smooth the rough edges.
  - f. Lay out and cut the required number of corner sheets (scraps may be used).
  - g. Install the corner bead. Use the corner-bead crimper to install the corner bead on the exterior corners of the corner post (nails may be used).
2. Finish the sheetrock joints. Check the recess of the nails in the sheetrock (Figure 051-236-1177-2).

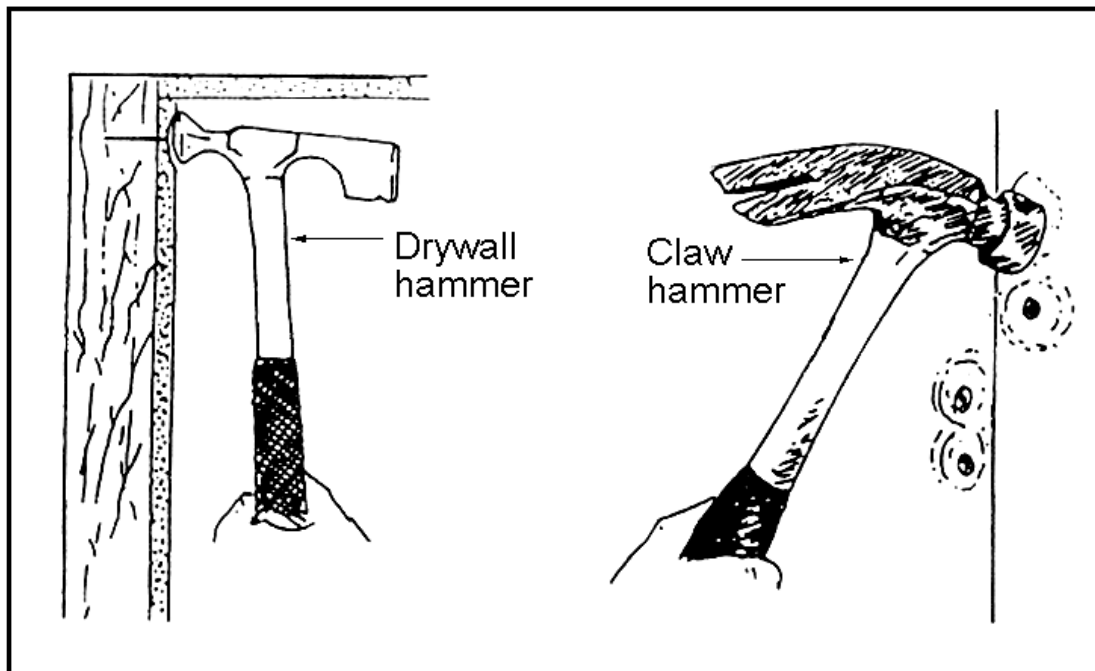

Figure 051-236-1177-2  
Dimpling of gypsum drywall

- a. Run the edge of the sheetrock knife over the nail heads (a clicking sound means the nail needs to be recessed).
  - b. Use a 4-inch knife and a mud pan to apply a smooth coat of joint compound over the nails (remove any excess joint compound).
3. Compound the joints (Figure 051-236-1177-3).

## Performance Steps

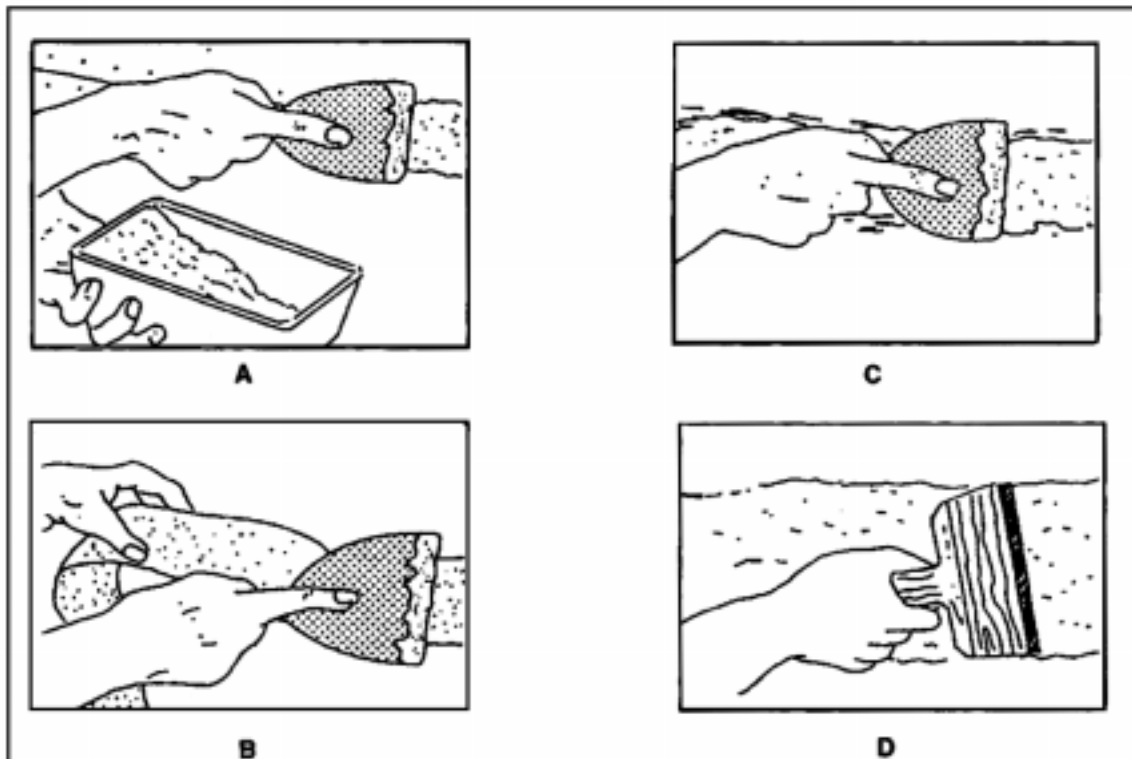

Figure 051-236-1177-3  
Finishing drywall joints

- a. Use a knife and a mud pan to apply a heavy coat of joint compound over the sheetrock joints, spreading it horizontally or vertically to ensure a good bond between the tape and the sheetrock. Fill in the tapered edges.
- b. Measure and cut the tape to the required joint lengths.
- c. Start at one end and work toward the opposite end using the knife to press the tape into the compound (remove all excess).

NOTE: Do not wrinkle the tape or leave air bubbles.

4. Compound the corners.
  - a. Measure and cut the tape to the required length and fold in half lengthwise (keeping both edges even).
  - b. Use a corner tape creaser and apply the tape at the top and work downward using your hand at the center to ensure that it is in the corner.
  - c. Use an inside corner tool and press the tape into the compound and work out the excess. (Do not wrinkle or leave bubbles).
5. Apply the joint compound to the sheetrock.
  - a. First coat. Apply a medium coat of joint compound and feather it with a 6-inch knife to about 2 or 3 inches on each side.
  - b. Second coat. Using a 4-inch knife, apply a second coat of joint compound over the tape and nails after the joint compound previously applied has dried completely.
  - c. Third coat. After the previously applied compound has completely dried, use a 10-inch knife and feather the joint compound out 10 to 12 inches on each side of the joint. Nails should not require a third coat, but it may be applied.

**Performance Steps**

6. Finish the surface. Use a damp sponge or fine sandpaper to smooth the surface. Ensure that there are no voids and that the surface is ready to paint.
7. Patch the sheetrock.
  - a. Small holes. Apply fiber mesh directly over the hole and cut the tape and apply with joint compound. Feather edges, sand, or sponge the area smooth after it has dried.
  - b. Fist-sized holes. Cut out a rectangle around the hole with a keyhole saw. Cut a piece of backing (1 inch by 2 inches or 1 inch by 3 inches) slightly larger than the hole, glue it to the backing by using either wallboard adhesive or mastic. Apply tape and coat it with joint compound. Feather, sand, or sponge the area smooth after it is dried.
  - c. Large holes. Cut out the center nearest to the stud. Nail or screw the sheetrock patch into the stud. Repeat steps a and b above.

**Evaluation Preparation:** Setup: Provide the soldier with the items listed in the conditions. Brief soldier: Tell the soldier to attach the sheetrock with the correct spacing of nails and screws. The sheetrock joints will be filled, taped, and smoothed ready for painting, with holes properly repaired.

<b>Performance Measures</b>	<b>Results</b>	
1. Hung sheetrock.	P	F
a. Attached sheetrock to the ceiling first.	P	F
b. Attached sheetrock to the walls.	P	F
c. Laid out the receptacles.	P	F
d. Attached the prepared sheet of sheetrock around the receptacles.	P	F
2. Finished the sheetrock joints.	P	F
3. Compounded the joints.	P	F
4. Compounded the corners.	P	F
5. Applied the joint compound to the sheetrock.	P	F
6. Finished the surface.	P	F
7. Patched the sheetrock.	P	F

**Evaluation Guidance:** Score the soldier a GO if all steps are passed (P). Score the soldier a NO-GO if any step is failed (F). If the soldier fails any step, show him how to do it correctly.

**References**

<b>Required</b>	<b>Related</b>
FM 5-426	
NAVEDTRA 12521	

## Subject Area 10: Floor and Wall Tile

**INSTALL RESILIENT FLOOR TILE****051-236-1176**

**Conditions:** As a carpentry and masonry specialist in a field environment, given a 16-foot measuring tape, a chalk line, a pencil, a notched trowel with a mud pan, floor tile with joint compound, Naval Education Training Command (NAVEDTRA) 12521 Builder 3 & 2, Volume 2, and a mission directive.

**Standards:** Correctly placed resilient tile on an untiled floor. Ensured that all the tiles were laid tight against one another, edge to edge, in a cross-grained pattern.

**Performance Steps**

1. Locate the center of the end walls before installing the tile.
  - a. Locate the center of the end walls of the room.
  - b. Establish a main centerline by snapping a chalk line between these two points.
  - c. Lay out another centerline at right angles to the main centerline. This line may be established by using a framing square or the triangulation method.
  - d. Make a trial layout of the tile along the centerlines.
    - (1) Measure the distance between the wall and the last tile.
    - (2) Move the centerline, if less than 1/2 tile, half the width of the tile (6 inches for a 12- by 12-inch tile) closer to the wall.

**NOTE:** This adjustment will eliminate the need to install border tiles that are too narrow. Since the original centerline is moved exactly half the tile size, the border tile will remain uniform on the opposite sides of the room.

- (3) Check the layout along the other centerline in the same way.
2. Install the floor tile.
  - a. Spread adhesive over one quarter of the total area, starting with the quarter farthest from the door, and work toward the door.
    - (1) Ensure that the floor surface is clean before spreading the adhesive.
    - (2) Spread the adhesive up to the chalk lines, but do not cover them.
    - (3) Use a notched trowel with the notch depth recommended by the manufacturer of the adhesive (Figure 051-236-1176-1).

**Performance Steps**

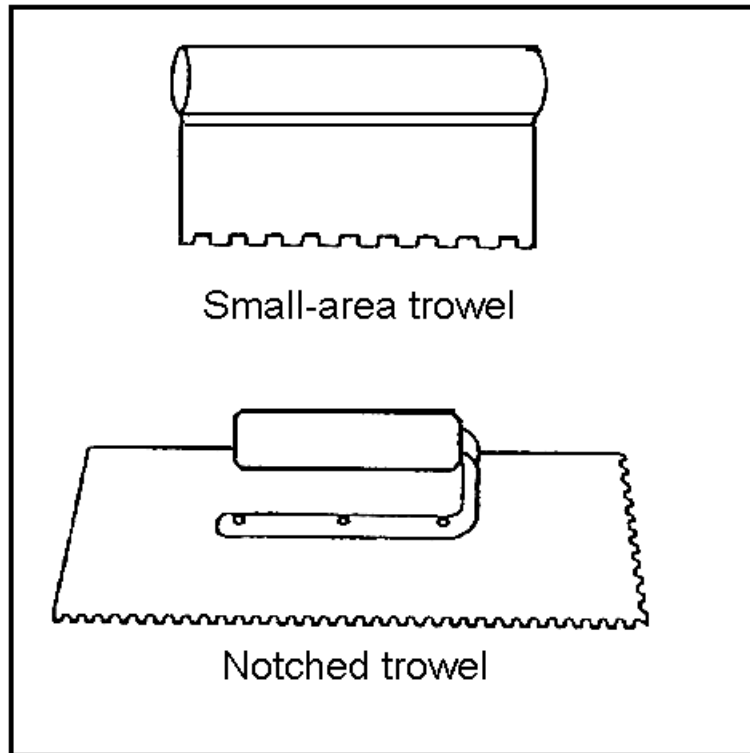

Figure 051-236-1176-1  
Tile-setting tools

- (4) Allow adhesive to take an initial set before a single tile is laid. The time required will vary from a minimum of 15 minutes to a much longer time, depending on the type of adhesive used.
- b. Start laying the tile at the center of the room.
  - (1) Ensure that the edge of the tile aligns with the chalk line.
  - (2) Lay rows by width, stair stepping additional rows, ensuring that the tiles are tight against one another in a cross-grained pattern.
  - (3) Install the border/edge tile around the room after all the full tiles have been laid.
    - (a) Lay out a border tile by placing a loose tile over the last tile in the outside row, with the grains running in opposite directions (if using a cross-grained pattern).
    - (b) Place the tile in position against the wall and mark a pencil line on the first tile.
    - (c) Cut the tile along the marked line (Figures 051-236-1176-2 and 051-236-1176-3).

**Performance Steps**

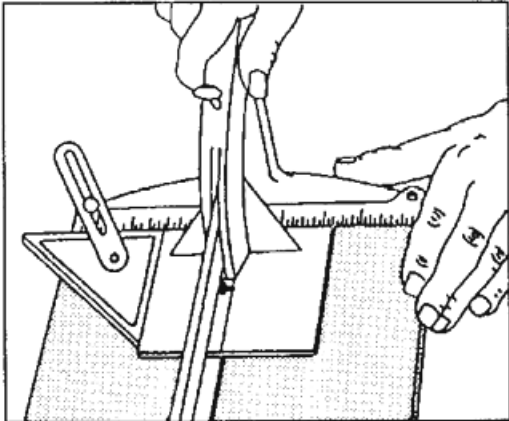

Figure 051-236-1176-2  
Tile cutter

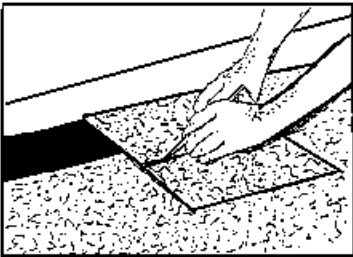

Figure 051-236-1176-3  
Ceramic tile cutter

- c. Remove any excess adhesive, after all tiles have been installed, by using a cleaner or solvent and the procedures approved by the manufacturer.

**Evaluation Preparation:** Setup: Provide the soldier with the items in the conditions. Brief soldier: Tell the soldier to correctly place resilient tile on an untiled floor. Ensure that all the tiles are laid tight against one another, edge to edge, in a cross-grained pattern.

Performance Measures	Results	
1. Located the center of the end walls before installing the tile.	P	F
2. Installed the floor tile.	P	F

**Evaluation Guidance:** Score the soldier GO if all steps are passed (P). Score the soldier NO-GO if any step is failed (F). If the soldier fails any step, show him how to do it correctly.

**References**  
**Required**  
FM 5-426

**Related**

STP 5-51B12-SM-TG

**References**

**Required**

NAVEDTRA 12521

**Related**



**INSTALL SUSPENDED CEILING****051-236-1189**

**Conditions:** As a carpentry and masonry specialist in a training environment, given Field Manual (FM) 5-426, a chalkline, a line level, a 4-foot level, an utility knife, a 22-ounce clawhammer, a hacksaw, tin snips, a tape measure, a stepladder, side cutting pliers, 6d and 8d common nails, anneal wire number 16 (tie wire), main runners, cross tees, wall angles, acoustical ceiling tile (2 feet by 4 feet), suspending devices (screw eyelets and suspending hooks), and an approved Hilti fastener for concrete or steel.

**Standards:** Installed a suspended ceiling according to FM 5-426. Measurements did not exceed +/- 1/8 inch.

**Performance Steps**

NOTE: Suspended ceilings are primarily designed for acoustical control; however, ceilings are also lowered to save on heat and air conditioning expenses. The most common-sized panels used are 2- by 2-foot and 2- by 4-foot panels. The 2- by 4-foot size works best if installing lighting because it fits the standard tube length.

1. Prepare for installation.
  - a. Develop an installation plan.
    - (1) Count the number of feet of wall angles, runners, tees, and other materials needed by using a plan.
    - (2) Plan for lighting and make decisions about how the panels will fit.
    - (3) Select a grid system (either steel or aluminum), the layout of a grid pattern, and the material required (Figure 051-236-1189-1).

## Performance Steps

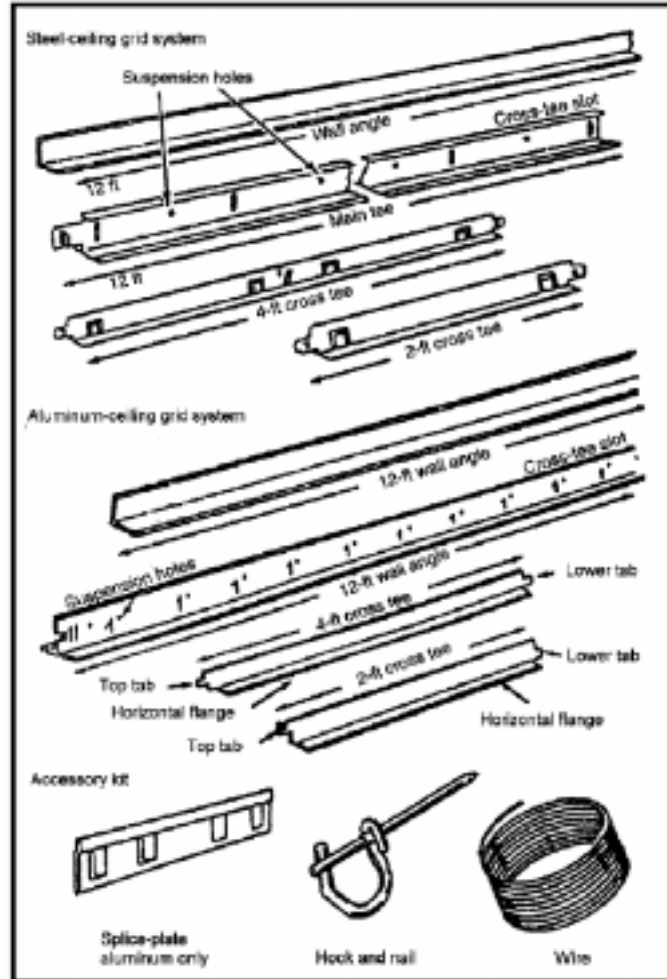

Figure 051-236-1189-1  
Grid-system components

- (4) Refer to Naval Education Training Command (NAVEDTRA) 12521, Chapter 5 and Figure 5-17, to view the major components of a steel and aluminum ceiling-grid system.
- b. Lay out a grid pattern.
  - (1) Measure the ceiling length and width at the new ceiling height if the ceiling length or width are not divisible by 2 foot, increase to the next higher dimension divisible by 2 foot. If the ceiling measures 13 feet 7 inches by 10 feet 4 inches, the dimensions should be increased to 14 feet by 12 feet for layout purposes.
  - (2) Draw the layout on paper.
    - (a) Ensure that the main tees run perpendicular to the joists.
    - (b) Position the main tees so that the border panels at the room edges are equal and as large as possible.
    - (c) Draw in cross tees so that the border panels at the room ends are equal and as large as possible.
  - (3) Determine material requirements.
    - (a) Determine the number of pieces of wall angle by dividing the perimeter by 10 and adding 1 additional piece for any fraction.

**Performance Steps**

- ( b) Determine the number of main tees and cross tees by counting them on the grid pattern layout.
- ( c) Determine the number of tiles by dividing the area (rounded length x rounded width of the ceiling) by the area of the tile. Determine the location of the main tees or runners and cross tees and sketch a plan of the ceiling for easy material figuring.

**2. Install the ceiling.****a. Establish the ceiling height.**

- (1) Mark the ceiling height on all four walls and stretch a string line between the nails driven at that height to check the horizontal levelness with a line level.
- (2) Make adjustments, if necessary. Use a chalkline to mark the height around the room by using a level to keep it horizontal. This will serve as a reference line.

NOTE 1: The standard height is 7 feet 6 inches, which is also considered a minimum height for lighting in a suspended ceiling.

NOTE 2: There must be a minimum of 2 inches between the new ceiling and the existing ceiling.

**b. Install the wall angle.**

- (1) Secure the wall angle along the reference line with nails or screws.
- (2) Butt pieces of the wall angle to span long distances and overlap pieces at the corners.
- (3) Account for the fraction of an inch thickness of the wall angle when cutting to butt against a piece on an adjacent wall and 051-236-1189-2).

**Performance Steps**

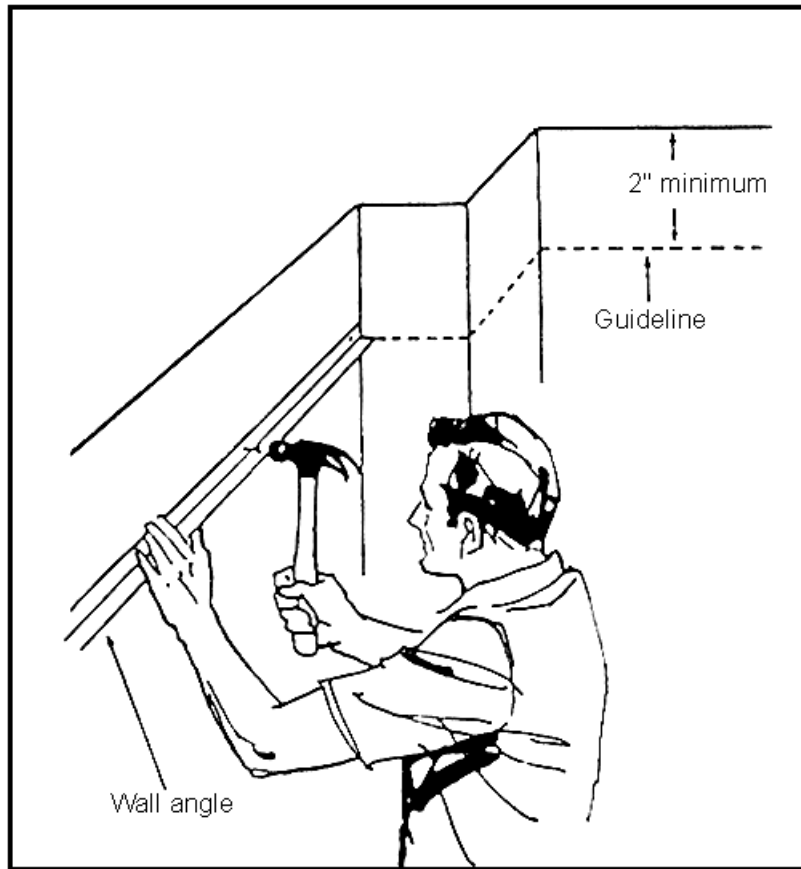

Figure 051-236-1189-2  
Wall angle installation

- c. Find the main tee (runner) height.
  - (1) Find the midpoints of the wall.
  - (2) Snap the chalklines across the joists or in either direction across the finished ceiling, at 2-foot intervals, starting at the midpoint of the wall or at one foot to either side, depending on the layout plan.
  - (3) Mark the locations of the cross tees on the walls parallel to the runners at 2 or 4 foot intervals, depending on panel size.
  - (4) Start these lines at the midpoint or 2 feet off center, depending on your layout.
  - (5) Attach a string line across the room from the nails driven at the bottom of the wall angle at its intersections with the cross tees. These lines mark the height at which the runners will be hung (Figure 051-236-1189-3).

Performance Steps

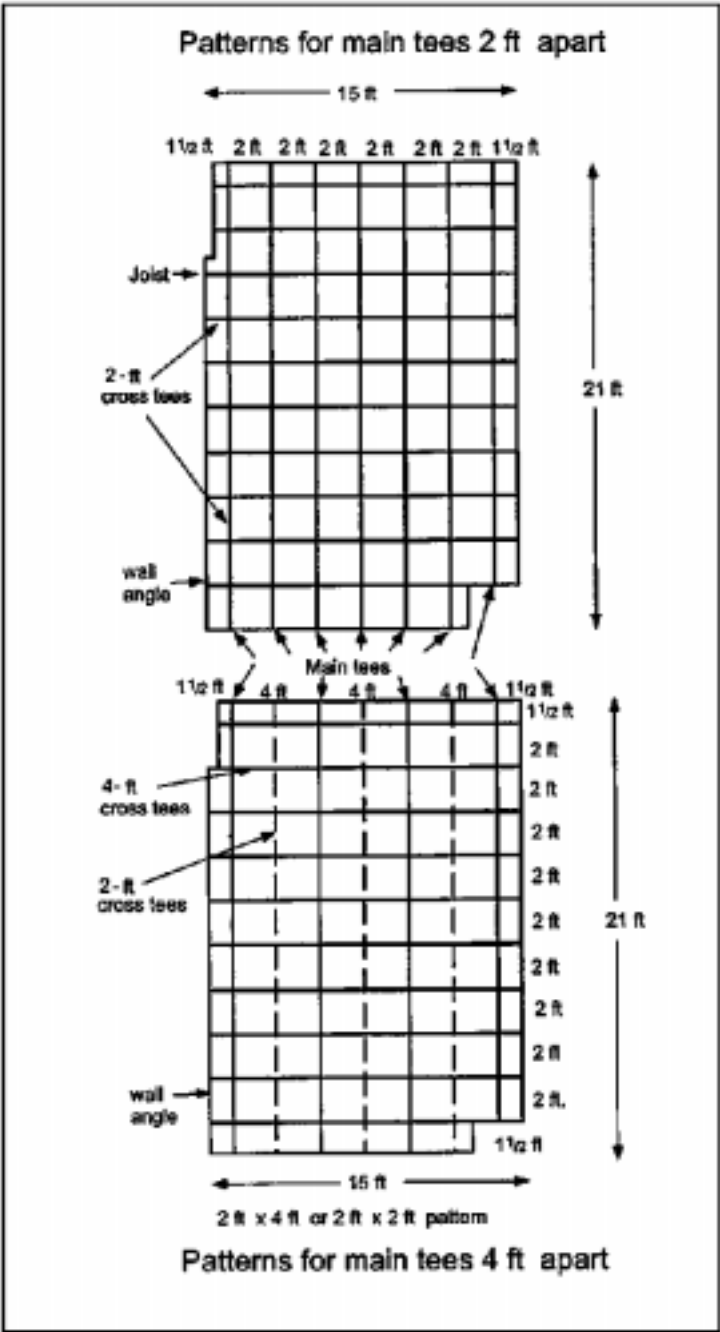

Figure 051-236-1189-3  
Grid layout for main tees

- d. Install the suspension wire.
  - (1) Ensure that suspension wires are installed every 4 feet along the main tees and on each side of all the splices.

**Performance Steps**

- (2) Start with the joists at either end of the ceiling and put a screw eye into every fourth joist at each chalk mark.
- (3) Twist a piece of suspension wire through each screw eye so that the wire hangs down about six inches below the ceiling line (this wire will be twisted onto the runners) (Figure 051-236-1189-4).

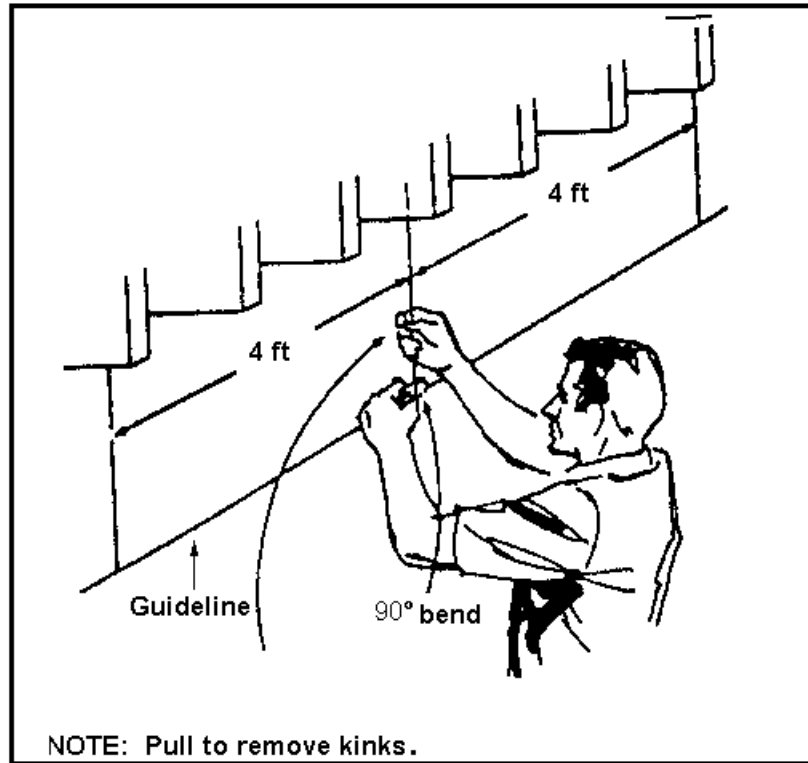

Figure 051-236-1189-4  
Suspension wire installation

- e. Install the main tees.
  - (1) Lay out main tees out from the center to ensure that the slots line up with the cross tee location, and cut are appropriate.
  - (2) Install tees 12 feet or less in length by resting the ends on opposite wall angles and inserting suspension wires.
  - (3) Cut tees over 12 feet in length to ensure that the cross tees will not intersect the main tee at a splice joint.
    - (a) Rest the cut end on the wall angle and attach suspension wires along the tee.
    - (b) Make necessary splices and continue attaching suspension wires along the tee until the tee rests on the opposite wall angle.
  - (4) Ensure that the main tees are level and secured before continuing (Figures 051-236-1189-5).

## Performance Steps

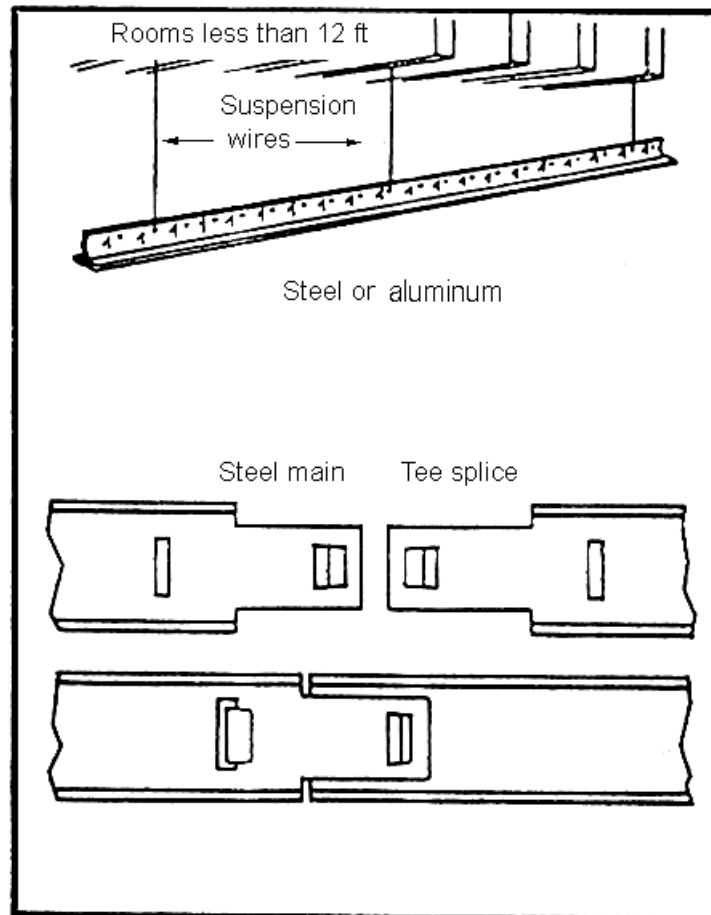

Figure 051-236-1189-5  
Main tee suspension and steel splice

- f. Install cross tees.
  - (1) Cut and install border tees on one side of the room.
  - (2) Install the remaining tees according to the grid pattern layout.
  - (3) Install the remaining border tiles at the opposite wall angle.
- g. Install acoustical panels.
  - (1) Install full-sized panels first.
    - (a) Handle panels with care and ensure that the surfaces are kept clean from handprints and smudges.
    - (b) Work from several cartons to avoid a noticeable change of uniformity, if on a large project.
  - (2) Cut and install border panels.

**Evaluation Preparation:** Setup: Provide the soldier with items listed in the conditions. Brief soldier: Tell the soldier to install a suspended ceiling according to FM 5-426. Measurements will not exceed +/- 1/8 inch.

**Performance Measures**

**Results**

1. Prepared for installation.
2. Installed the ceiling.

P	F
P	F

**Evaluation Guidance:** Score the soldiers GO if all steps are passed (P). Score the soldier NO-GO if any step is failed (F). If the soldier fails any steps, show him how to do it correctly.

**References**

**Required**

FM 5-412  
FM 5-426  
NAVEDTRA 12521

**Related**



## INSTALL CERAMIC WALL TILE

051-236-1192

**Conditions:** As a carpentry and masonry specialist on a training site, given a 16-foot measuring tape, a pencil, a framing square, a notched trowel, a mud pan, wall tile, joint compound, a rubber-surfaced trowel, tile cutters, safety glasses, work gloves, a preformed wall, Field Manual (FM) 5-426, and Naval Education Training Command (NAVEDTRA) 12521 Builder 3 & 2, Volume 2.

**Standards:** Correctly placed ceramic wall tile on a constructed wall, with all the tiles spaced evenly from top to bottom, and without damaging equipment.

### Performance Steps

1. Determine if the floor is level to within 1/8 inch over the entire length of the partition wall. If it is--
  - a. Measure up one full tile size, if level to within 1/8 inch, from the floor at both corners (inside and outside) on the door/window side of the partition wall.
  - b. Draw a horizontal line between these points (Figure 051-236-1192-1). This line represents the top of the first field tile.

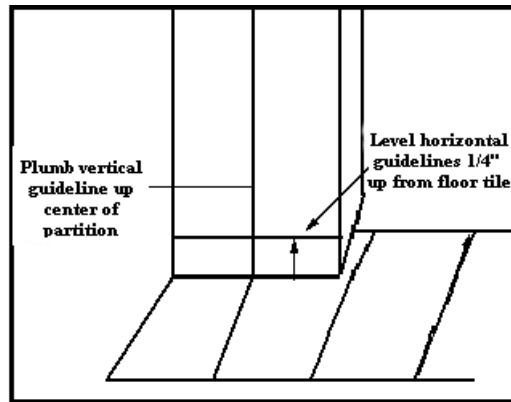

Figure 051-236-1192-1  
Wall tile, View I

2. If you determine the floor is not level to within 1/8 inch--
  - a. Measure up one full tile size from the lowest corner.
  - b. Draw a level, horizontal line from corner to corner.
3. Determine the center of the horizontal line and use a framing square to make a line perpendicular from the center point extending up from the floor through the center point.
4. Lay the entire first course of tiles (Figure 051-236-1192-2).

**Performance Steps**

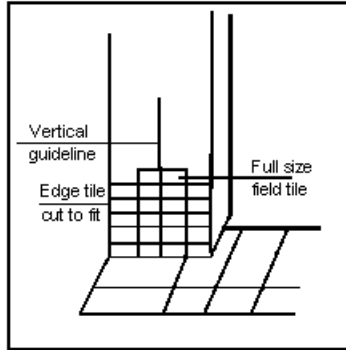

Figure 051-236-1192-2  
Wall tile, View II

5. Measure, mark, and cut the base tile, if applicable (Figure 051-236-1192-3).

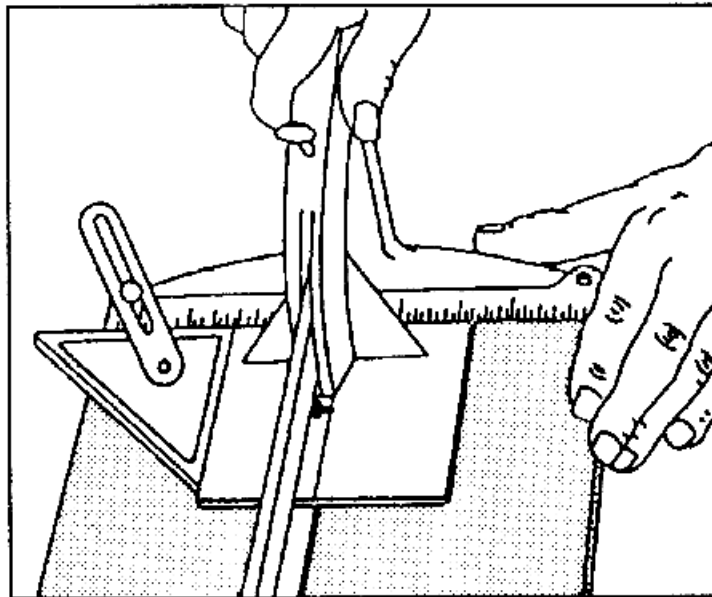

Figure 051-236-1192-3  
Tile cutter

- a. Cut the tile by placing it on the floor and then place the cutter so the scoring wheel of the cutter is aligned with the desired cut.
  - b. Pull the scoring wheel across the tile. Depress the cutting lever with steady pressure until the tile snaps.
6. Start at the base of the wall and spread a light layer of joint compound over the section of the wall being covered. Spread it up to the guideline, but do not cover.
  7. Align the tile at the centerline and with the top flush along the horizontal line.

**Performance Steps**

8. Tap the tile lightly to set it once it is in place.
  9. Repeat step 5b on the other side of the centerline.
  10. Lay the remaining tiles (5 courses), staggering them from one side of the centerline to the other and tap them lightly in place.
- NOTE: Cap tile may be used for the final course, if available and if specified.
11. Measure and cut the end tile after all the tiles are in place.
  12. Use a straight edge, after all the tile are set, to ensure that the surface of the tile is the same. If not, tap lightly to bring it flush with the others.
  13. Grout the tile.
    - a. Use a rubber-surfaced trowel to spread the joint compound over the tile surface (Figure 051-236-1192-4).

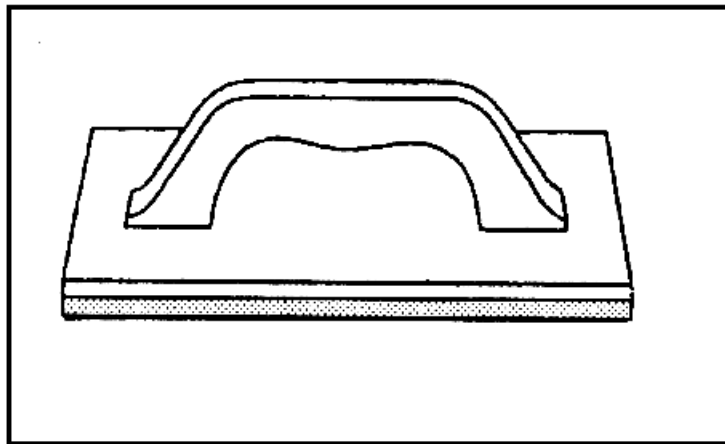

Figure 051-236-1192-4  
Rubber-surfaced trowel

- b. Work the trowel in an arc. Hold the trowel at a slight angle so that the joint compound is forced into the spaces between the tile.
- c. Clean the excess off with a damp sponge after the tile is grouted.

**Evaluation Preparation:** Setup: Provide the soldier with the items listed in the conditions. Brief soldier: Tell the soldier to place ceramic wall tile on a constructed wall correctly, with all the tile spaced evenly from top to bottom, and without damaging equipment.

**Performance Measures**

1. Determined the floor was level to within 1/8 inch over the entire length of the partition wall.
2. Determined the floor was not level to within 1/8 inch.
3. Determined the center of the horizontal line and used the framing square to make a line perpendicular from the center point extending up from the floor through the center point.

**Results**

- |   |   |
|---|---|
| P | F |
| P | F |
| P | F |

<b>Performance Measures</b>	<b>Results</b>	
4. Laid the entire first course of tile.	P	F
5. Measured, marked, and cut the base tiles.	P	F
6. Started at the base of the wall and spread a light layer of joint compound over the section of the wall being covered. Spread it up to the guideline, but did not cover.	P	F
7. Aligned the tile at the centerline with the top flush along the horizontal line.	P	F
8. Tapped the tile lightly to set it once it was in place.	P	F
9. Repeated step 5b on the other side of the centerline.	P	F
10. Laid the remaining tiles (5 courses), staggering them from one side of the centerline to the other and taped them lightly in place.	P	F
11. Measured and cut the end tile after all the tiles were in place.	P	F
12. Used a straight edge, after all the tiles were set, to ensure that the surface of the tile is the same. If not, tapped lightly to bring it flush with the others.	P	F
13. Grouted the tile.	P	F

**Evaluation Guidance:** Score the soldier a GO if all steps are passed (P). Score the soldier a NO-GO if any step is failed (F). If the soldier fails any step, show him how to do it correctly.

**References**

**Required**  
 FM 5-426  
 NAVEDTRA 12521

**Related**

## Subject Area 11: Roof Systems and Coverings

**APPLY ROOF COVERINGS****051-236-1172**

**Conditions:** As a carpentry and masonry specialist in a field environment, given Field Manual (FM) 5-426, construction prints and specifications, a carpenter's tool kit, a completed roof system, composition shingles, a metal-drip edge and flashing, number 15 felt, nails, an extension ladder, a staple gun, tin snips, gloves, a hard hat, paper, and a pencil.

**Standards:** Applied a roof covering according to FM 5-426 and the construction prints and drawings. Applied underlayment with a 2-inch top lap and a 4-inch side lap, secured the drip edge along the roof perimeter, and applied shingles with a 5-inch exposure.

**Performance Steps**

**NOTE:** Correct use of roofing terms is the mark of a good worker and a necessity for good construction.

1. Identify the following roofing terms:
  - a. Roof covering. The roof covering, or roofing, is part of the exterior finish. It should provide the building and its content long-lived waterproof protection from rain, snow, wind, and to some extent, heat, and cold.
  - b. Roof covering terminology.
    - (1) Square. The amount required to cover 100 square feet of the roof's surface.
    - (2) Coverage. The amount of weather protection provided by the overlapping of shingles.
    - (3) Shingle surfaces.
      - (a) Shingle width (W). This refers to the total measurement across the top of either a strip type or individual type of shingle.
      - (b) Top lap (TL). The area that one shingle overlaps another in the course (row) below.
      - (c) Side lap (SL). The area that one shingle overlaps a shingle next to it in the same course.
      - (d) Head lap (HL). The area that one shingle overlaps a shingle two courses below. Head lap is measured from the bottom edge of an overlapping shingle to the nearest top edge of an overlapped shingle.
      - (e) Exposure (E). The area that is exposed (not overlapped) in a shingle. Refer to Figure 051-236-1172-1.

**Performance Steps**

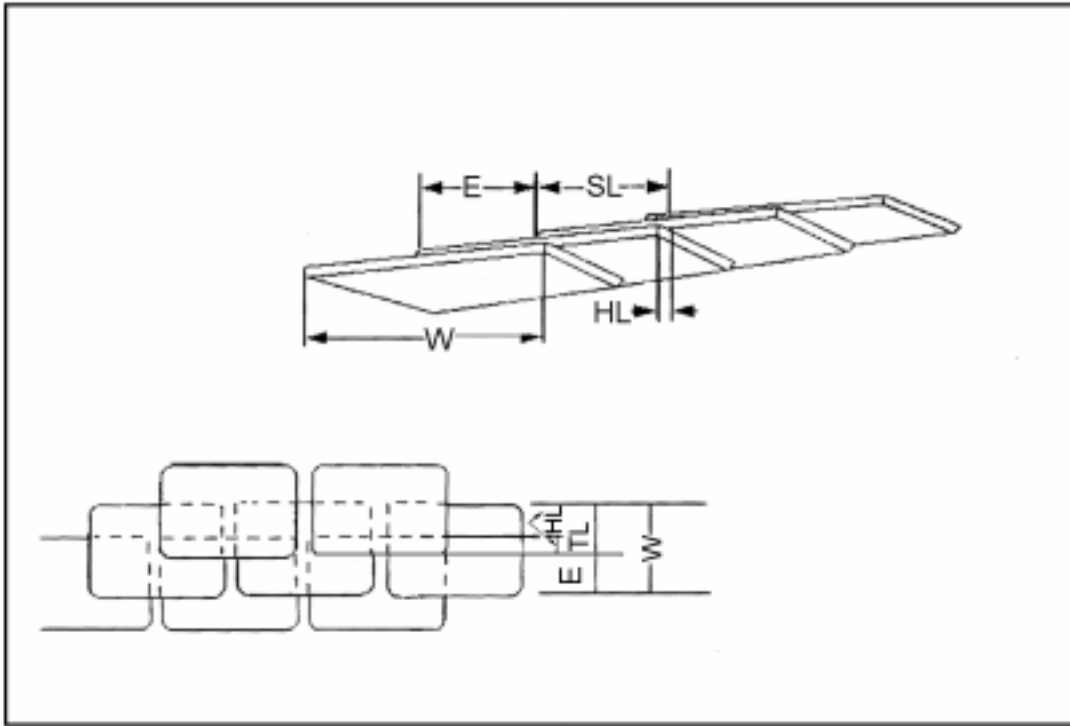

Figure 051-236-1172-1  
Shingle surfaces

NOTE: Slope and pitch are often incorrectly used synonymously when referring to the incline of a sloped roof.

- (4) Slope. The incline of a roof as a ratio of vertical rise to horizontal run. It is expressed sometimes as a fraction but typically as X-in-12. For example, a 4-in-12 slope for a roof that rises at the rate of 4 inches for each foot (12 inches) of run.
  - (5) Pitch. The incline of a roof as a ratio of the vertical rise to twice the horizontal run. It is expressed as a fraction. For example, if the rise of a roof is 4 feet and the run is 12 feet, the roof is designated as having a pitch of 1/6 ( $4/24 = 1/6$ ).
2. Identify the following roof-system components (refer to Naval Education Training Command [NAVEDTRA] 12521).
- a. Underlayments. A layer of asphalt covering the roof sheathing.
  - b. Flashing.
    - (1) Flashing consists of specially constructed pieces of sheet metal or other materials used to protect the building from water seepage (Figure 051-236-1172-2).

Performance Steps

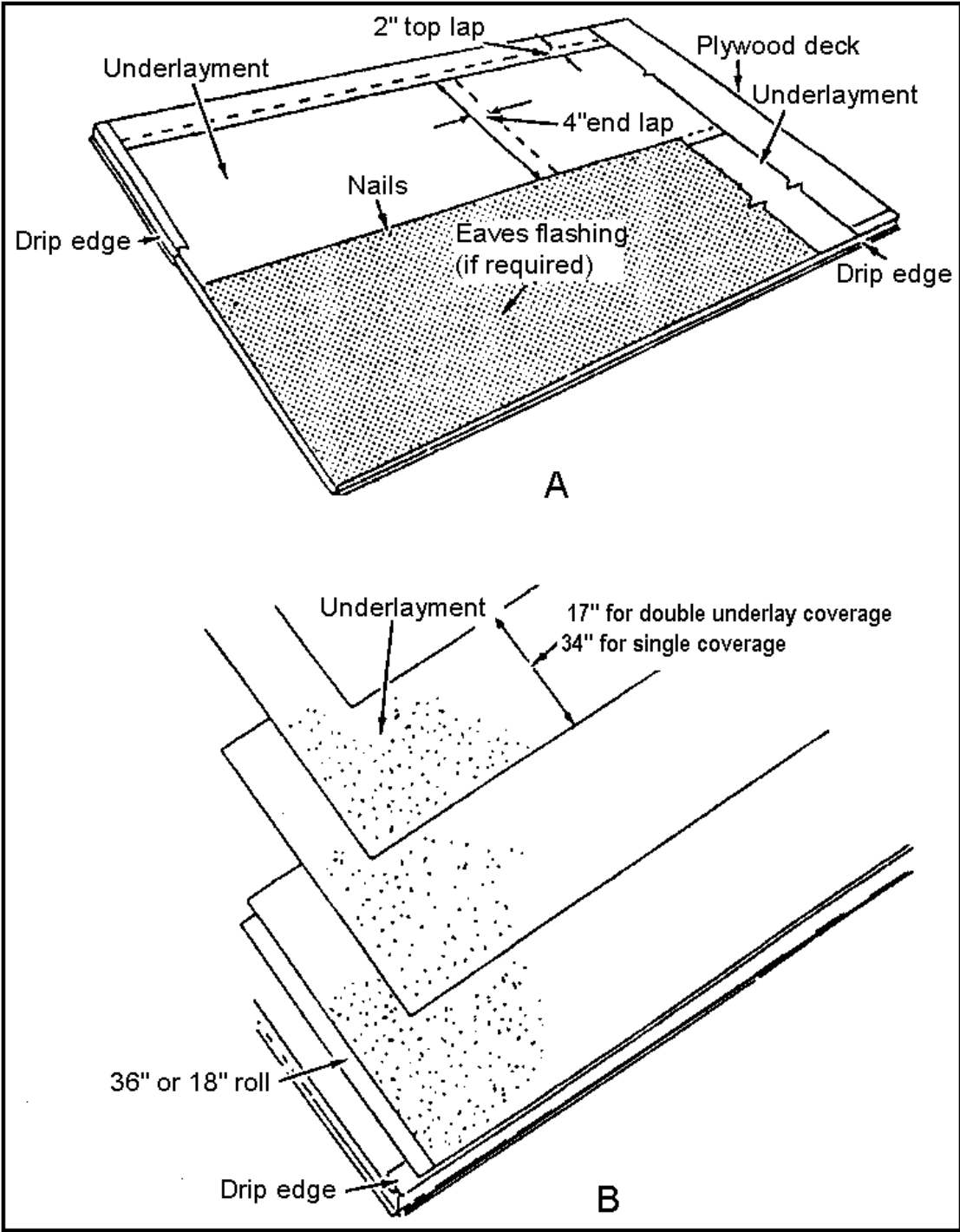

Figure 051-236-1172-2  
Square-butt asphalt strip slab

(2) Flashing must be made watertight and shed water. Flashing materials used on roofs may be asphalt-saturated felt, metal, or plastic.

### Performance Steps

- (3) Roof edges along the eaves and rake should have a metal-drip edge or flashing.
    - (a) Ensure that the drip edge extends back about 3 inches from the roof edge and bend downward over the edge.
    - (b) Lay the underlayment over the drip edge at the eaves.
    - (c) Place the underlayment under the drip edge at the rake.
    - (d) Use galvanized nails, spaced 8 to 10 inches apart, for fastening the drip edge to the sheathing.
  - c. Roof cement.
    - (1) Roofing cements are used for installing eave flashing, for flashing assemblies, for cementing tabs of asphalt shingles and laps in sheet metal material, and for repairing roofs.
    - (2) Roofing cement types include plastic asphalt cements, lap cements, quick-setting asphalt adhesives, roof coatings, and primers.
  - d. Shingles. The two most common shingle types are asphalt and fiberglass, both of which come in various strip shapes.
    - (1) Asphalt. Asphalt (composition) shingles are available in several patterns. They come in strip form or as individual shingles. Shingles are manufactured on a base of organic felt (cellulose) or an organic glass mat. The felt or mat is covered with a mineral-stabilized coating of asphalt on the top and bottom. The topside is coated with mineral granules of a specified color. The bottom side is covered with sand, talc, or mica.
    - (2) Fiberglass. Improved technologies have made the fiberglass mat competitive with organic felt. The weight and thickness of a fiberglass mat is usually less than organic felt. The popularity of fiberglass-based shingles may be attributed to their low cost. Fiberglass shingles are of the same dimensions as asphalt shingles.
  - e. Roof covering types.
    - (1) Roll roofing. Roll roofing is organic or inorganic asphalt-saturated felt and has a mineral surface.
    - (2) Wood shingles and shakes.
    - (3) Tiles. Tile roofing consists of clay, roll, mission, and flat tiles.
3. Apply a roof coverings.
- a. Install a drip edge. Use roofing nails, spaced about 12 inches on center, to install a drip edge along the eaves.
  - b. Install the underlayment. Start at the eave and staple the felt paper securely. Ensure that it runs flush with the drip edge and the rake, and extends past the valley 12 inches, if a valley exists.
  - c. Prepare layout guidelines.
    - (1) Locate the center of the area to be covered and snap a chalk line from the eave to the ridge. Ensure that the line is square with the rake.
    - (2) Snap an additional guideline 6 inches on either side of the centerline.
    - (3) Snap a line running 11 1/2 inches from the eave.
    - (4) Measure, mark, and snap chalk lines at 10-inch intervals from the first horizontal guideline.
  - d. Use roofing nails, spaced about 12 inches on center, to install a drip edge along the rakes.
  - e. Install the starter course.
    - (1) Invert the shingle; place the top of the shingle flush with the chalk line and the edge flush with the offset centerline.
    - (2) Install the remaining shingles (inverted) along the eaves, ensuring that there is a 12-inch overlap at the valleys and 6 feet at the hips.
  - f. Install the remaining courses.
    - (1) Start at the centerline and install the first course right side up and flush over the starter course (tabs are offset at 6 inches from the starter course).
    - (2) Install the remaining courses alternating each starting point between the centerline. Offset the centerline and leave 5 inches to the weather (5-inch exposure).



**Performance Steps**

NOTE: Every other course should end up on a horizontal guideline. If a valley is present, ensure that the ends of the shingles extend at least 12 inches beyond the center of the valley. Ensure the tabs of the second course are not in line with the tabs of the first course.

- g. Finish the hip.
  - (1) Cut the overlapping shingles to ensure that there is complete coverage by the cap.
  - (2) Apply shingle caps (1/3 of the shingle) over the hip, maintaining a 5-inch exposure to the weather.
- h. Install the ridge cap.
  - (1) Center the shingle tab on the ridge at the rake, flush with the drip edge.
  - (2) Install the remaining ridge caps, aligned with the first, maintaining a 5-inch exposure to the weather.

**Evaluation Preparation:** Setup: Provide the soldier with the items listed in the conditions. Brief soldier: Tell the soldier to apply a roof covering according to FM 5-426 and the construction prints and drawings.

<b>Performance Measures</b>	<b>Results</b>	
1. Identified roofing terms.	P	F
2. Identified roof-system components.	P	F
3. Applied roof coverings.	P	F

**Evaluation Guidance:** Score the soldier a GO if all steps are passed (P). Score the soldier a NO-GO if any step is failed (F). If the soldier fails any step, show him how to do it correctly.

**References**

**Required**  
 FM 5-426  
 NAVEDTRA 12521

**Related**

Subject Area 12: Maintenance

**PERFORM MAINTENANCE ON CARPENTRY/MASONRY TOOLS**

**051-236-1147**

**Conditions:** As a carpentry and masonry specialist in a field environment, given a carpentry and masonry toolbox, an emery cloth, steel wool, rags, Society of Automotive Engineers (SAE) 10 oil, the required replacement parts, paper, a pencil, and a Technical Manual (TM) 9-243.

**Standards:** Checked all carpentry and masonry tools for broken parts and maintenance was performed according to TM 9-243.

**Performance Steps**

NOTE: Refer to TM 9-243 for maintenance of tools.

1. Perform maintenance on steel tapes. Tapes should be kept clean, dry, and stored where they will not become bent or damaged.
2. Perform maintenance on levels. Levels should be kept clean, dry, and stored where they will not become bent or the vials will not be damaged.
3. Perform maintenance on plumb bobs. Keep the plumb bob dry and free of rust or corrosion. Coat lightly with lubricant and place in a protective box. For long term storage, apply a heavy coat of oil and wrap the plumb bob in oil-soaked paper.
4. Perform maintenance on squares. Ensure that the squares are kept clean. Apply a light coat of oil to all metal surfaces after using. Replace the square if it has a loose stock.
5. Perform maintenance on pliers. Remove dirt and grease with a clean rag and apply a light coat of oil after each use. Store the pliers in a toolbox or hang them on racks when they are not in use.
6. Perform maintenance on hammers. Check for cracks in the handle and replace the handle as needed. Periodically rub a small amount of linseed oil on the wood handle to prevent the wood from drying out and shrinking.
7. Perform maintenance on heads. Check for cracks in handles, loose heads, and missing or makeshift wedges to ensure that the head is tight. Replace the head if it has a worn or chipped face or claw. Lightly lubricate the metal when storing the hammer for a lengthy period. Wipe oils and grease from rubber parts to prevent damage to rubber.
8. Perform maintenance on screwdrivers.
  - a. When a screwdriver becomes nicked or the edge becomes rounded it can be reground or filed. The sides must be parallel to keep the tool from lifting from the screw slot, and the tip must be square, and at right angles to the sides and to the blade. Replace a screwdriver that has a worn or damaged handle or round tip.
  - b. After use, wipe the screwdriver clean and place it in a rack or toolbox. For long term storage, apply rust-preventive compound to all metal surfaces and store the screwdriver in a dry place.
9. Perform maintenance on adjustable open-end wrenches. Clean wrenches after use. Wrenches that come in sets should be returned to their cases after use. Apply a thin film of oil to the metal parts of all wrenches before storage. For long term storage, cover the wrenches with a rust-preventive compound.
10. Perform maintenance on chisels. Protect the cutting edges by installing protective covers. Store the chisels in racks or where they may not be chipped or broken. Lubricate with a light coat of oil before storing. Regrind broken or chipped edges before using.

## Performance Steps

11. Perform maintenance on files. Break in a new file by using it first on brass or smooth iron. Clean the files often with a brush or file scorer and store them in separate holders.
12. Perform maintenance on shaping stones. Prevent glazing of stone by applying light oil while using. Wipe excess oil and grit from the stone with a cleaning rag after each use. Clean the stone with dry cleaning solvent when it becomes glazed or gummed up. Store in a clean place and/or wrap in clean cloth.
13. Perform maintenance on glass cutters. Ensure that the cutter blades remain sharp by using a sharpening stone. When not in use, apply a light film of oil on the cutting edges and store where the blades do not come in contact with metal. For long-term storage, coat the entire cutter with a rust-preventive compound.
14. Perform maintenance on knives. Protect the sharp cutting edges and apply oil to metal surfaces to prevent rust. Use a preventive compound for long-term storage.
15. Perform maintenance on wrecking bars.
  - a. Wrecking bars require little maintenance. Wipe them clean after each use and cover with light oil before storing.
  - b. Keep bar ends in their original shape by filing or grinding.
16. Perform maintenance on half hatchets. Keep the cutting edge sharp by filing or grinding. Clean and oil metal parts before storage and promptly replace wooden handles when needed.
17. Perform maintenance on saws.
  - a. Keep the cutting edge sharp by filing or grinding. Clean and oil, when needed.
  - b. Prevent damage to blades.
  - c. Keep the saw teeth in top condition by touching up the teeth with a file occasionally.
  - d. Remove the rusted saw blade from the handle for storage.
18. Perform maintenance on planes. When not in use, place the plane on its side to protect the cutting edge. Keep the cutting edge sharp and free of nicks. Apply a light coat of oil to metal parts to prevent rust and store the plane by withdrawing the cutting edge into the mouth of the plane.
19. Perform maintenance on masonry trowels.
  - a. Wash trowels thoroughly to remove all mortar or concrete and then dry them. Place a light coat of oil on the metal surface.
  - b. Wash wooden handles and coat them with linseed oil.
20. Perform maintenance on floats. Clean with water and apply a light coat of oil to the blade and linseed oil to the handle.
21. Perform maintenance on electrical power tools.
  - a. Keep all power tools, especially the housing intake and exhaust holes, clear and free of dust and dirt at all times.
  - b. Examine power tool cords for exposed loose wires and for damaged insulation.
  - c. Wipe power cords frequently to prevent deterioration from oil or grease.
  - d. Check cord plugs for loose prongs or cracked casings.
  - e. Never hold or drag electrical tools by the cord.
  - f. Apply a light coat of oil to the cutting surfaces of tools to prevent rusting.
  - g. Store power tools in their properly designated containers when not in use.

**Evaluation Preparation:** Setup: Provide the soldier with the items listed in the conditions. Brief soldier: Tell the soldier to perform maintenance on all carpentry and masonry tools according to TM 9-243.

<b>Performance Measures</b>	<b>Results</b>	
1. Performed maintenance on steel tapes.	P	F
2. Performed maintenance on levels.	P	F
3. Performed maintenance on plumb bobs.	P	F
4. Performed maintenance on squares.	P	F
5. Performed maintenance on pliers.	P	F
6. Performed maintenance on hammers.	P	F
7. Performed maintenance on heads.	P	F
8. Performed maintenance on screwdrivers.	P	F
9. Performed maintenance on adjustable open-end wrenches.	P	F
10. Performed maintenance on chisels.	P	F
11. Performed maintenance on files.	P	F
12. Performed maintenance on shaping stones.	P	F
13. Performed maintenance on glass cutters.	P	F
14. Performed maintenance on knives.	P	F
15. Performed maintenance on wrecking bars.	P	F
16. Performed maintenance on half hatchets.	P	F
17. Performed maintenance on saws.	P	F
18. Performed maintenance on planes.	P	F
19. Performed maintenance on masonry trowels.	P	F
20. Performed maintenance on floats.	P	F
21. Performed maintenance on electrical power tools.	P	F

**Evaluation Guidance:** Score the soldier GO if all steps are passed (P). Score the soldier NO-GO if any step is failed (F) If the soldier fails any step, show him how to do it correctly.

**References**

- Required**  
 DA Form 2404  
 DA Pam 738-750  
 TM 9-243

**Related**

## Subject Area 13: Concrete Structures

**CONSTRUCT A CONCRETE-WALL FORM****051-236-1163**

**Conditions:** As a carpentry and masonry specialist in a field environment, given Field Manuals (FMs) 5-426 and 5-428, construction prints and specifications, a carpenter's tool kit, an excavated earth footing, plywood, 2- by 4-inch and 1- by 6-inch lumber, number 4 reinforcing material, snap ties, tie wire, nails, a sledge hammer, a circular saw, sawhorses, a wheelbarrow, a shovel, bolt cutters, goggles, gloves, hearing protection, a hard hat, paper, and a pencil.

**Standards:** Identified components of a concrete wall form, constructed a double-wale wall form, and installed reinforcing material according to FMs 5-426 and 5-428 and the construction prints and specifications. Constructed formwork to within +/- 1/8 inch of the specifications. Secured all the wedges and braces. Performed all operations without injury to personnel.

**Performance Steps**

1. Identify the following components of a concrete-wall form:
  - a. Form design.
    - (1) Formwork is important because it--
      - (a) Protects the concrete.
      - (b) Aids in the curing of the concrete.
      - (c) Supports any reinforcing bars or conduit embedded within it.
      - (d) Represents up to one-third of a concrete structure's total cost.
    - (2) Factors influencing form design are--
      - (a) The nature of the structure.
      - (b) The availability of equipment and form materials.
      - (c) The anticipated reuse of the forms.
      - (d) The familiarity with construction methods that influence the formwork design.
      - (e) The strength of the forming materials and the loads they must support.
      - (f) The concrete's final shape, dimensions, and surface finish.
  - b. Form characteristics.
    - (1) Ensure that the forms are tight, rigid, and strong. Loose forms permit loss of cement which can result in--
      - (a) Honeycombing. Honeycombing is when the concrete is not satisfactorily consolidated or vibrated air pockets form within the concrete and present a pocked appearance.
      - (b) Sand streaking. Sand streaking occurs when concrete loses too much water due to loose forms; the water carries sand with it through the gaps in the formwork and causes streaking.
    - (2) Ensure that the forms are braced enough to align them and strong enough to hold the concrete.
    - (3) Take special care in bracing and tying down forms used for configurations, such as retaining walls. Ensure that the forms are wide at the bottom and taper toward the top.
    - (4) Ensure that wall forms are braced properly. The concrete in wall forms, such as the first pour, tends to lift the form above its proper elevation.
    - (5) Reuse forms by constructing them in a manner that allows easy removal and replacement with minimal damage.
  - c. Form materials.
    - (1) Forms are generally made from wood, metal, earth, and fiber.
      - (a) Wood. Wood forms are the most common by far, because they are economical, easy to produce and handle, and can adapt to many shapes. For added economy, reuse form lumber for roofing, bracing, and similar purposes.

**Performance Steps**

- (b) Metal. Metal forms are used for added strength or when construction will be duplicated at more than one location. Steel forms are common for large unbroken surfaces, such as retaining walls, tunnels, pavements, curbs, and sidewalks.
  - (c) Earth. Earth forms are acceptable in subsurface construction if the soil is stable enough to retain the desired concrete shape. Earth forms require less wood construction and resist settling better than other types of forms.
  - (d) Fiber. Fiber forms are prefabricated from impregnated waterproof cardboard and other fiber materials. Fiber forms are ideal for round concrete columns and other applications where shapes are feasible, because they require no form fabrication at the job site and save considerable time.
- d. Wall-form components.
- (1) Footings. Footings are the part of the foundation that rests on the earth and distributes the load over a larger ground area (this prevents the structure from sinking into the ground). The three common types are--
    - (a) "I" shaped. The "I" shaped footing is used where building walls set directly on the footing.
    - (b) "L" shaped. The "L" shaped footing is used where a building is placed against another building or close to the property line.
    - (c) Inverted "T." The inverted "T" is the most common and can be placed monolithically or separately by using a keyway.
  - (2) Footing formwork for construction.
    - (a) Trenches are excavated to the proper dimensions if the earth is stable, and concrete is poured in the trench.
    - (b) Formwork must be constructed if the earth is not stable or firm.
    - (c) Formwork is usually constructed of plywood and held in place with stakes and braces.
    - (d) Spreaders are used to keep the sides of the formwork the correct distance apart.
  - (3) Sheathing.
    - (a) Sheathing forms the vertical surfaces of a concrete wall, but is placed horizontally.
    - (b) Sheathing must be watertight. Although sheathing made from tongue and groove gives the smoothest and most watertight concrete surface, plywood or fiber-based hardboard may also be used.
  - (4) Studs. If not reinforced by studs, the weight of the plastic concrete will cause the sheathing to bulge. Therefore, vertical studs are added to the wall form for rigidity. Studs are made from single 2- by 4-inch or 2- by 6-inch lumber material.
  - (5) Wales.
    - (a) Wales reinforce the studs when they extend upward more than five feet.
    - (b) Wales are made from doubled 2- by 4-inch or 2- by 6-inch lumber material and are lapped at the form corners to add rigidity.
    - (c) Double wales not only reinforce the studs, but also tie prefabricated panels together and keep them aligned.
  - (6) Braces. Of the many types of braces, the most common is a combination of a diagonal member and a horizontal member nailed to a stake at one end and to a stud or wale at the other. The diagonal member makes a 20- to 60-degree angle with the horizontal member.
  - (7) Spreaders. Spreaders are small pieces of wood placed between the sheathing panels to maintain the proper wall thickness between them. They are cut to the same length as the wall thickness. Because friction, not fasteners, holds the spreaders in place, you can remove the fasteners easily before the concrete hardens.
  - (8) Tie wires. Tie wires secure through the spreaders to pull them out when the fresh concrete exerts enough pressure against the sheathing to permit removal.
  - (9) Tie rods. Tie rods are sometimes used instead of tie wires in the same function because the rods are much easier to work with.
  - (10) Shoe plates. Shoe plates are nailed into the foundation or footing and must be carefully placed to maintain the wall dimensions and alignment. Studs are tied into the shoe plate (Figures 051-236-1163-1 and 051-236-1163-2).

Performance Steps

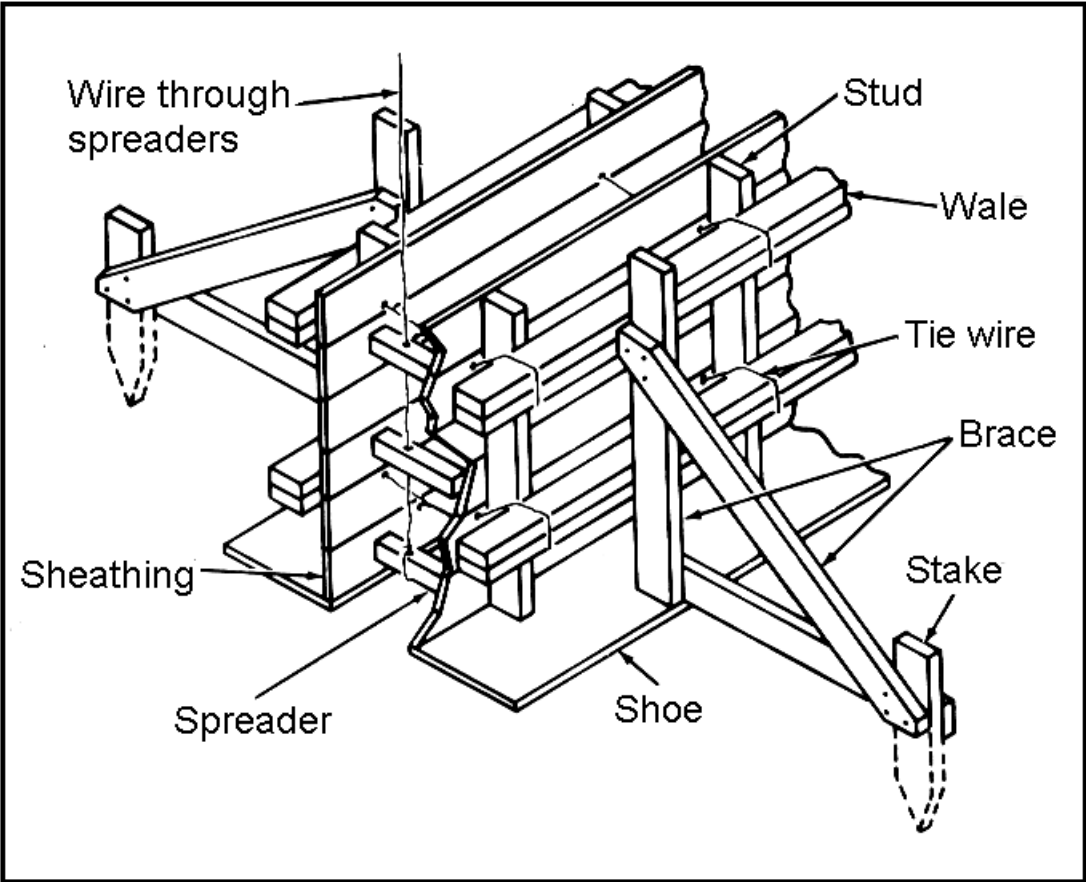

Figure 051-236-1163-1  
Wood form for a concrete-panel wall

**Performance Steps**

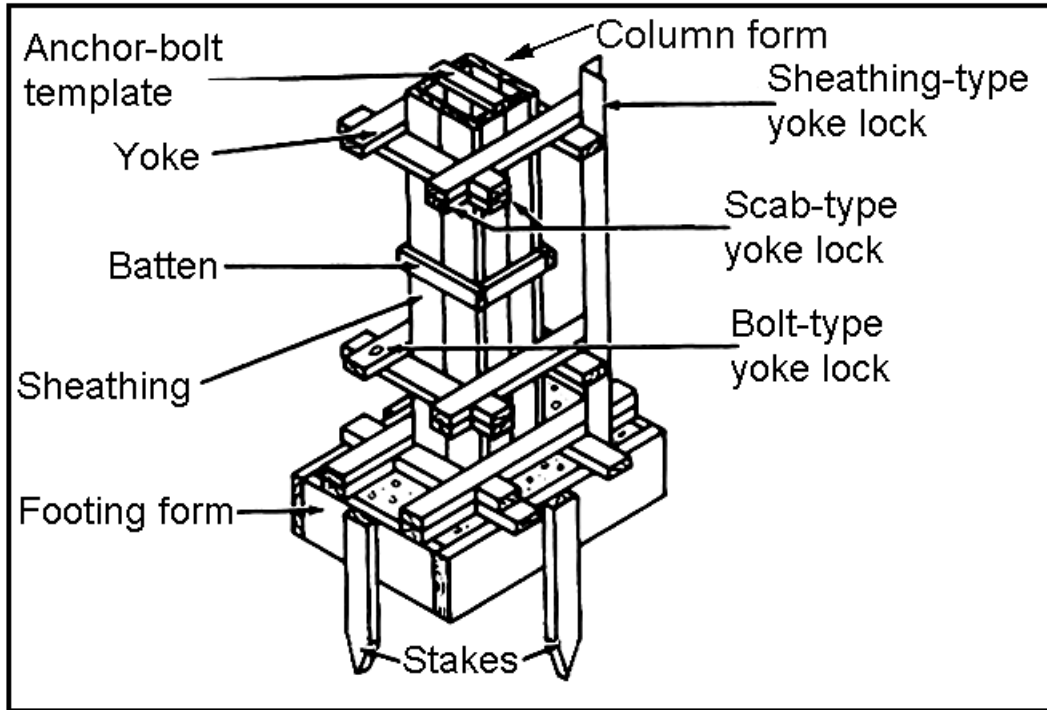

Figure 051-236-1163-2  
Form for a concrete column and footing

NOTE: Refer to FM 5-426, Chapter 4.

2. Construct a concrete wall.

a. Footing-formwork construction.

- (1) Use the following information to construction bearing wall footings:
  - (a) Bearing walls, also called a load-bearing walls, are exterior walls that serve not only as an enclosure, but also transmits structural loads to the foundation.
  - (b) Form sides are made of 2-inch lumber and whose width equals the footing depth.
  - (c) Stakes hold the sides in place while spreaders maintain the correct distance between them.
- (2) Use the following information to lay footings:
  - (a) Walls require a footing when the supporting soil cannot withstand the wall load without further means of load redistribution.
  - (b) Footings must be wider than the wall thickness, but a qualified engineer must determine the actual footing width and thickness for high walls that will carry a heavy load.
  - (c) Footings must rest below the frost line to prevent foundation heaving and settlement.
  - (d) Footings 16 inches wide and approximately 8 inches thick is usually large enough for an ordinary one-story building having an 8-inch thick wall.
  - (e) Footings are normally made from concrete leveled on top to receive the brick stone or concrete foundation walls.



**Performance Steps**

- ( f ) Wall footings should be laid after conducting a site layout to determine the outer boundaries of the footing. When digging the footing site, ensure that the footing rests below the frost line. Prepare the subgrade (usually several inches of gravel specified in the job specification) and lay 2-inch form sides. Install stakes, bracing, and spreaders. Check all components for plumb and ensure that the tops of the form are level.
- ( g ) Some footings may call for a keyway to be made. A keyway is made in the wet concrete by placing a 2- by 2-inch board along the center of the wall-footing form. Remove the board after the concrete is dry. An indentation or key is left in the concrete. When pouring the foundation wall, the key provides a tie between the footing and wall. Make the tie stronger by drilling holes in the wooden keyway and tie vertical reinforcing bars into the footing reinforcing.
- b. Double-wale wall-form construction.
  - (1) Snap chalk lines on the footing (foundation) representing the location of the formwork.
  - (2) Construct wall sections.
    - ( a ) Cut studs and sheathing to length.
    - ( b ) Nail studs and sheathing together to form wall panels. Use double-headed forming nails so stripping the forms will ensure that the forming materials can be reused.
    - ( c ) Install one wall-form section.
    - ( d ) Construct and install wales. Toe nail the wales to the studs to secure them until the tie wire is installed later. Ensure that the ends of the wales land on the center of the studs or extend past the formwork.
    - ( e ) Construct and install shoe plates.
    - ( f ) Oil the forms. Always oil concrete forms that will contact the cement to allow easy removal of forms. The interior face of the wall sections may also be oiled before erecting the wall sections.
    - ( g ) Assemble and install the reinforcing material.
    - ( h ) Construct and install spreaders.
    - ( i ) Construct and install strongbacks.
    - ( j ) Plumb the formwork and secure the knee bracing. Place a 4-foot level on the inside of the formwork. Plumb and secure the knee bracing on one side of the formwork. Measure, cut, and install the knee bracing on the opposite side of the formwork.

NOTE: Refer to Field Manual (FM) 5-428 for reinforcing material installation.

**Evaluation Preparation:** Setup: Provide the soldier with the items listed in the conditions. Brief soldier: Tell the soldier to identify the components of a concrete wall form, construct a double-wale wall form, and install the reinforcing material according to FMs 5-426 and 5-742 and the construction prints and specifications. Perform all operations without injury to personnel.

**Performance Measures**

- 1. Identified the components of a concrete-wall form.
- 2. Constructed a concrete wall.

**Results**

P F  
P F

**Evaluation Guidance:** Score the soldier a GO if all steps are passed (P). Score the soldier NO-GO if any step is failed (F). If the soldier fails any step, show him how to do it correctly.

**References**

**Required**  
FM 5-426  
FM 5-428

**Related**

## CONSTRUCT A COLUMN FORM

051-236-1164

**Conditions:** As a carpentry and masonry specialist in a field environment, given Field Manuals (FMs) 5-426 and 5-428, the construction prints and specifications, a carpenter's tool kit, a completed concrete footing, 2- by 4-inch and 1- by 6-inch lumber, reinforcing material, high chairs, snap ties, tie wire, nails, a circular saw, sawhorses, bolt cutters, goggles, gloves, hearing protection, a hard hat, and a pencil.

**Standards:** Constructed a concrete-column form and installed reinforcing material according to FMs 5-426 and 5-428 and the construction prints and specifications. Constructed all formwork to within +/- 1/8 inch of the specification. Performed all operations without causing damage to equipment or environment and without injury to personnel.

### Performance Steps

1. Identify the following components of a concrete-column form:

NOTE: Reinforced concrete is often used to support columns in heavy construction. Concrete columns have a heavy-load bearing capacity.

- a. Sheathing.
  - (1) Sheathing serves to form the surfaces of the concrete, as it does in wall forms.
  - (2) Sheathing runs vertically in column forms to reduce the number of saw cuts.
  - (3) Corner joints must be nailed firmly to ensure that they are watertight.
- b. Yokes.
  - (1) Yokes are horizontal reinforcements in the form of a rectangle that wraps around a column to prevent the plastic concrete from distorting the form. The small horizontal dimensions of a column do not require vertical reinforcement.
  - (2) Yokes serve the same purpose as a stud in a wall form.
  - (3) Yokes can be locked in place by using sheathing, scabs, or bolt-type yoke locks.
- c. Battens. Battens are narrow strips of lumber placed directly over the joints to fasten several pieces of vertical sheathing together.
- d. Yoke locks. Yoke locks are used to reinforce the yokes. Several different types can be used.
  - (1) Bolt-type locks are bolts that are used with washers and nuts. A hole is drilled where the yoke joins and secures with the bolt, washer, and nut.
  - (2) Scab locks are scabs fastened where the yoke joins at a 90-degree angle.
  - (3) Sheathing-type locks are either wood or metal that are formed at a 90-degree angle and secured to the yokes on the outer edges (Figure 051-236-1164-1).

## Performance Steps

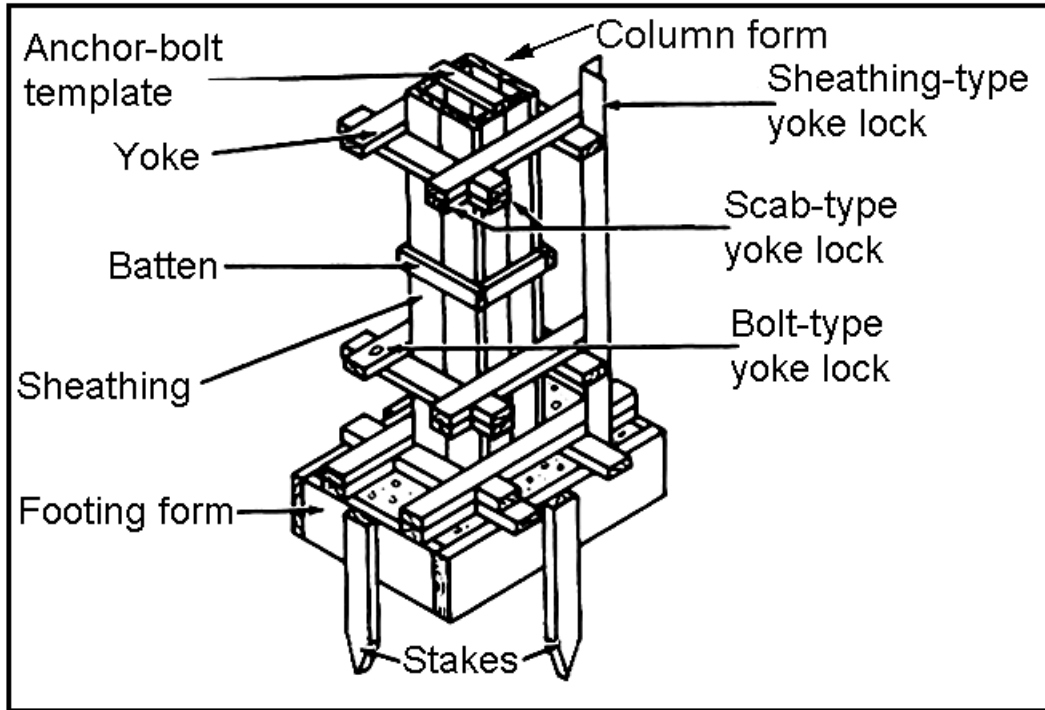

Figure 051-236-1164-1  
Column and footing form

2. Construct a concrete-column form. Construct column forms from the lowest point to the highest point. Follow these steps when constructing a concrete form:
  - a. Ensure that column forms are 12 inches by 18 inches for inside dimensions and 5 feet high.
  - b. Ensure that the following materials are available.
    - (1) Sheathing: 1-inch by 6-inch by 10-foot board sheathing
    - (2) Yokes: 2-inch by 2-inch by 10-foot dimensional lumber
    - (3) Battens: 2-inch by 4-inch by 10-foot boards
    - (4) Yoke locks: Sheathing type
    - (5) Number 4 reinforcing material: 6-foot lengths
    - (6) Tie wire.
  - c. Build the footing form.
    - (1) Place footings at the same time the column concrete is placed.
    - (2) Build the footing formwork to the dimensions called for in the drawings and specifications.
    - (3) Install the reinforcement stakes.

NOTE: Ensure that the ground is compacted and the subbase is prepared before constructing any formwork.

- d. Build the column-form sides.
  - (1) Build the column-form sides in units first, by securing the sheathing lengths with battens.
  - (2) Nail the yokes to the column-form sides. Determine yoke spacings by the specifications.
- e. Fasten the column sides. After the four sides of the column form have been constructed, fasten them together and set them in place.

NOTE: The column form should have a clean-out hole in the bottom to remove construction debris. The pieces of lumber removed from the clean-out hole should be nailed to the form so they can be replaced right before placing concrete in the column.

- f. Install the yoke locks.

**Performance Steps**

- (1) Sheathing-type yoke lock. Fasten this type of lock to the yokes with nails or screws.
  - (2) Bolt-type yoke lock. Drill holes where the yokes intersect and insert bolts, washers, and nuts. Tighten until they are snug. If available, wing nuts work the best.
  - (3) Scab-type yoke lock. Cut scabs out of scrap 2- by 4-inch lumber and secure with wood fasteners.
3. Install reinforcing material.
- a. Assemble steel for column ties.
    - (1) Assemble steel for column ties into cages by laying the vertical bars for one side of the column horizontally across a couple of sawhorses.
    - (2) Slip the proper number of ties over the bars. Add the remaining vertical bars and then space the ties out, as required, by the placing plans.
    - (3) Wire a sufficient number of intersections together to make the assembly rigid. This allows it to be hoisted and set as a unit.
  - b. Raise the column form.
  - c. Tie the column form to the reinforcing material.
    - (1) Raise the column form and tie it to the dowels or reinforcing material from below (the footing reinforcing material). This holds it firmly in place at the base.
    - (2) Erect the column form and tie the reinforcing steel to the column form at 5-foot intervals.
    - (3) Check the space between the reinforcing steel and concrete forms. Check the minimum clear space between the reinforcing steel and concrete forms with the maximum size aggregate in the concrete mix design. The aggregate then will not become lodged between the form and the reinforcing steel, preventing any further concrete from passing by.

**Evaluation Preparation:** Setup: Provide the soldier with the items listed in the conditions. Brief soldier: Tell the soldier to construct a concrete-column form and install reinforcing material according to specification. Perform all operations without damage to equipment or the environment and without injury to personnel.

<b>Performance Measures</b>	<b>Results</b>	
1. Identified the components of concrete-column form.	P	F
2. Constructed a concrete-column form.	P	F
3. Installed reinforcing material.	P	F

**Evaluation Guidance:** Score the soldier GO if all steps are passed (P). Score the soldier NO-GO if any step is failed (F). If the soldier fails any step, show him how to do it correctly.

**References**

<b>Required</b>	<b>Related</b>
FM 5-426	
FM 5-428	

**CONSTRUCT AN OVERHEAD FORM****051-236-1165**

**Conditions:** As a carpentry and masonry specialist in a field environment, given Field Manuals (FMs) 5-426 and 5-428, construction prints and specifications, a carpenter's tool kit, a completed concrete footing and column, 2- by 4-inch and 1- by 6-inch lumber, number 4 reinforcing material, high chairs, snap ties, tie wire, nails, a circular saw, sawhorses, bolt cutters, goggles, gloves, hearing protection, a hard hat, and a pencil.

**Standards:** Constructed an overhead-beam form and installed reinforcing material according to FMs 5-426 and 5-428 and the construction prints and specifications. Constructed all formwork to within +/- 1/8 inch of the specifications. Performed all operations without damage to equipment or the environment and without injury to personnel.

**Performance Steps**

1. Construct a concrete-overhead-beam form (Figure 051-236-1165-1).

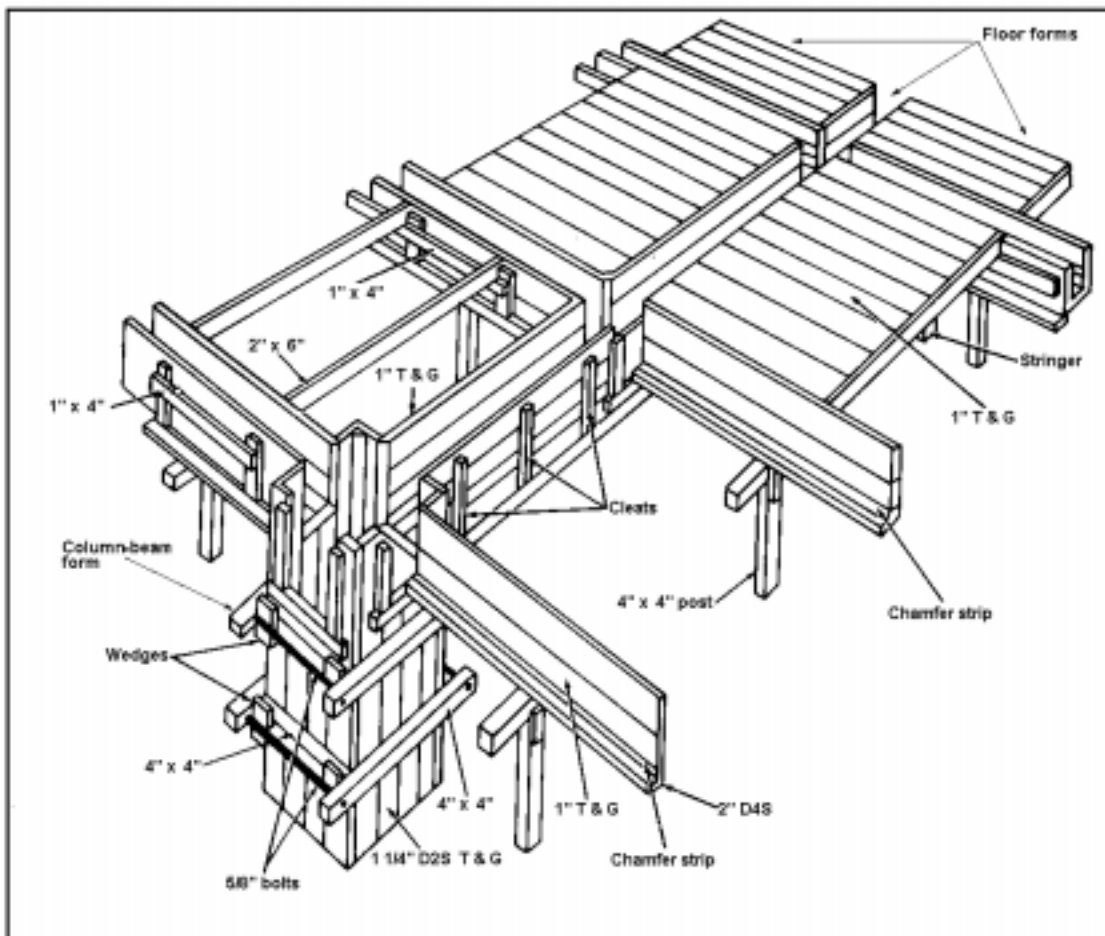

Figure 051-236-1165-1  
Concrete column and overhead beam assembly

- a. Set the form bottom.

**Performance Steps**

- (1) Make the width of the soffit out of 2-inch material, exactly like that of the member being formed, and its length equal to the distance between the columns or the spans.
  - (2) Cut the two ends of the form bottom at a 45-degree angle to produce a chamfer at the junction of the beam bottom and column.
  - b. Nail the chamfer strips with beveled ends to the beam-form bottom, flush with the outside edge.
- NOTE: Chamfer strips are small pieces of wood (about 1 inch by 1 inch).
- c. Cut the studs to the length called for in the specifications.
  - d. Cut and fasten the sheathing.
    - (1) Use either 1-inch tongue and groove lumber or plywood.
    - (2) Cut the sheathing should be cut to the length called for in the specifications and fasten it to the studs to create both side panels.
    - (3) Nail sheathing sides so that they overlap the bottom piece of the form.
  - e. Cut and install the temporary spreaders.
    - (1) Cut the temporary spreaders to the beam as stated in the specifications.
    - (2) Install the temporary spreaders by using double-headed forming nails.
  - f. Install the shoring.
    - (1) Use a large quantity of shoring to offset the downward hydrostatic pressure placed on the form bottom. Commercial adjustable-metal forms are available and are probably the best and easiest type of shoring to use on beam and girder forms (Figure 051-236-1165-2). Heavy timber such as 4- by 4-inch lumber is normally available and works fine.

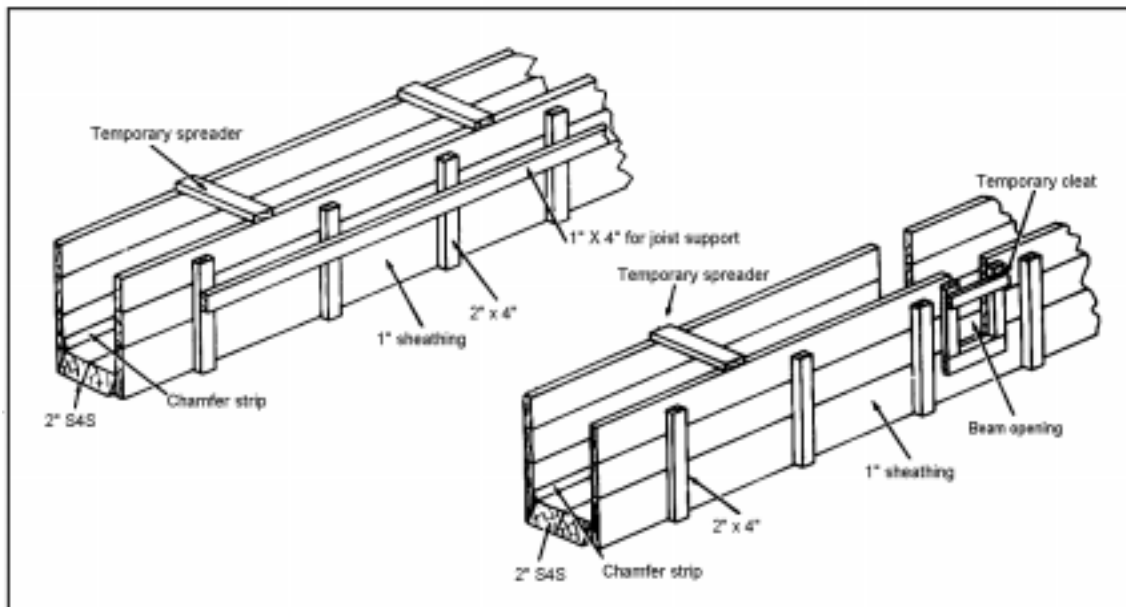

Figure 051-236-1165-2  
Beam and girder form

- (2) Install shoring so that the beam form remains level.

2. Install reinforcing material.

NOTE 1: Reinforced steel in beams provides tensile strength to that part of the beam's cross section that undergoes tension due to an applied load. It adds compression strength and additional shear strength.

NOTE 2: Tension or compression bars may be straight or bent and are held in alignment by the vertical bars that resist shear.

- a. Install high chairs or beam bolsters in the bottom of the form.

**Performance Steps**

- b. Cut and splice longitudinal bars, if necessary.
- c. Cut the stirrups.
- d. Wire the tie stirrups to the longitudinal pieces.
- e. Install the assembly into the form on top of the high chairs or bolsters (Figure 051-236-1165-3).

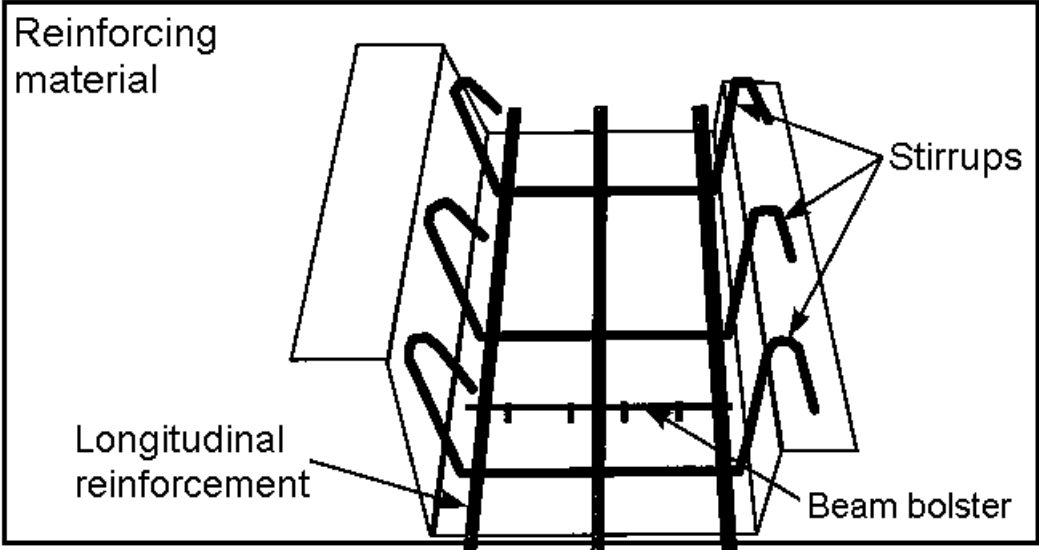

Figure 051-236-1165-3  
High chair or bolster

**Evaluation Preparation:** Setup: Provide the soldier with the items listed in the conditions. Brief soldier: Tell the soldier to construct an overhead-beam form and install reinforcing material according to FMs 5-426 and 5-428. Perform all operation without damage to equipment or environment and without injury to personnel.

<b>Performance Measures</b>	<b>Results</b>	
1. Constructed a concrete-overhead-beam form.	P	F
2. Installed reinforcing material.	P	F

**Evaluation Guidance:** Score the soldier GO if all steps are passed (P). Score the soldier a NO-GO if any step is failed (F). If the soldier fails any step, show him how to do it correctly.

**References**

<b>Required</b>	<b>Related</b>
FM 5-426	
FM 5-428	

## CONSTRUCT A CONCRETE-SLAB FORM

051-236-1166

**Conditions:** As a carpentry and masonry specialist in a field environment, given Field Manual (FM) 5-428, construction prints and specifications, a carpenter's tool kit, 1- by 6-inch and 2- by 4-inch lumber or metal forms with 1-inch diameter stakes, 4- by 4-inch wire mesh, high chairs, tie wire, nails, a sledge hammer, a circular saw, a shovel, sawhorses, goggles, gloves, hearing protection, a hard hat, paper, and a pencil.

**Standards:** Identified components of a concrete slab form, constructed a concrete slab form from wood and from steel, and installed reinforcing material according to FM 5-428 and the construction prints and specifications. Constructed all formwork to within +/- 1/8 inch of the specifications. Performed all operations without damage to equipment or the environment and without injury to personnel.

### Performance Steps

1. Identify the following components of a concrete-slab form:
  - a. Slab on grade forms. Placing a slab on grade is a routine job that is probably done more than any other concrete job. Forms for concrete slabs placed on grade are usually quite simple. Concrete is cast on compacted earth or a gravel base and forms are required only for the edges.
  - b. Wooden slab-form.
    - (1) Forms or form edges. Plywood, sheathing material, or stock lumber is used for forms and form edges. Wood forms are commonly used for smaller projects and projects that require irregular shapes, such as curved edges.
    - (2) Stakes. Stakes are normally made from 2- by 4-inch stock. They are hammered firmly into the ground and slightly lower than the form sides. Form sides are nailed to the stake.

NOTE 1: Metal stakes can be used. If metal stakes are used, then the forms sides can be secured to the stake by using tie wire.

NOTE 2: Knee bracing can be used as additional bracing. Use knee bracing if soft soil conditions are present or if the thickness of the slab requires additional bracing.

- c. Steel-slab-form.
  - (1) Forms or form edges.
    - (a) Steel-edge forms are commonly used on larger jobs and for highway work. Large projects provisions are made for the wheels of mechanical strike-off bars (screeding devices) and floats to ride on the top flange of steel-edge forms.
    - (b) Steel-edge forms are positioned in the same manner as wooden forms. These forms can easily be connected together for long sides (Figure 051-236-1166-1).



## Performance Steps

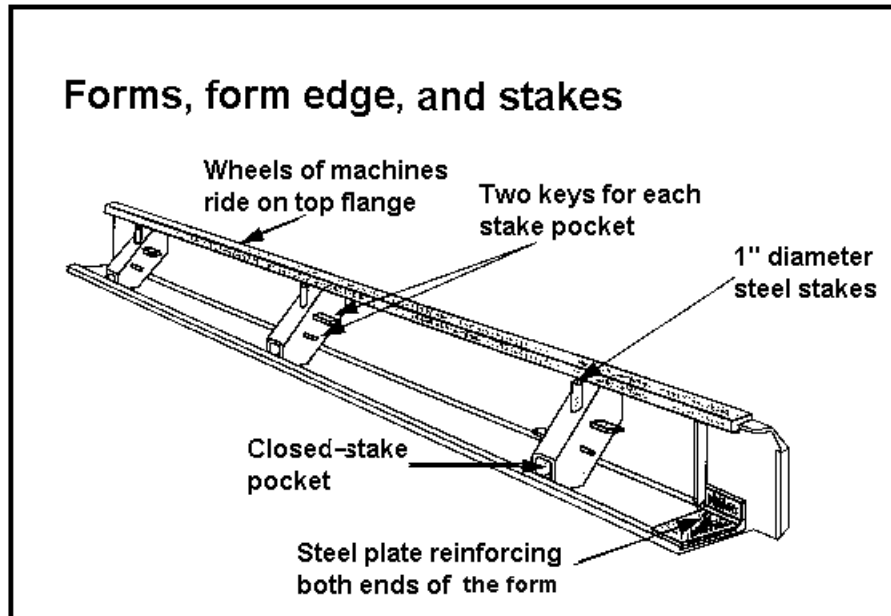

Figure 051-236-1166-1  
Steel-slab edge form

- (2) Stakes. One-inch diameter metal stakes are used to secure the formwork in place.

NOTE: Wooden and steel forms can be used together.

### d. Steel reinforcing material.

- (1) Welded wire fabric (mesh) are used in many slabs small enough not to require reinforcing bars. It comes in rolls and sheets which must be cut to fit individual applications. The individual sections of fabric must be tied together or lapped to form a continuous sheet of fabric. Welded wire is useful for small slabs because it prevents the slab from cracking.
- (2) Reinforcement bars.
  - (a) Reinforcing bars offer a much greater bond and strength factor than welded wire fabric. Large slabs that are required to support great weights will normally require reinforcing bars.
  - (b) Wire mesh is laid on top of the reinforcement bars to keep the slab from cracking.
  - (c) High chairs are used to support the reinforcement material at the correct height.
  - (d) Slab bolsters are similar to a beam bolster, however, they are used in slabs with a smaller depth.

NOTE: High chairs keep the reinforcement material in place during concrete placement; they are used for reinforcement bars and wire mesh.

### e. Joints.

- (1) Construction joints. If the slab is placed in sections, construction joints must be made between them, which will transmit shear from one to the other. This is done by attaching a small, tapered piece of wood to one edge of the slab form.
- (2) Control joints.
  - (a) Control joints control the location of the cracks that occur in a concrete slab as a result of the concrete shrinking.
  - (b) Control-joint forms may be made in several ways. One common method is to insert a wood or metal strip into the slab, top or bottom, to form a plane of weakness. Another method is to make a cut pathway through the slab with a masonry blade.

**Performance Steps**

- (3) Expansion joints. Expansion joints are necessary in slab construction to provide space for the slab to expand, due to changes in temperature, without exerting damaging pressure on the member adjacent to it.
  - f. Anchor bolts. Anchor bolts are embedded in the concrete with the thread exposed above the concrete slab. They are used to fasten soleplates for wood forms to the concrete structure.
2. Construct a wooden-form slab (Figure 051-236-1166-2).

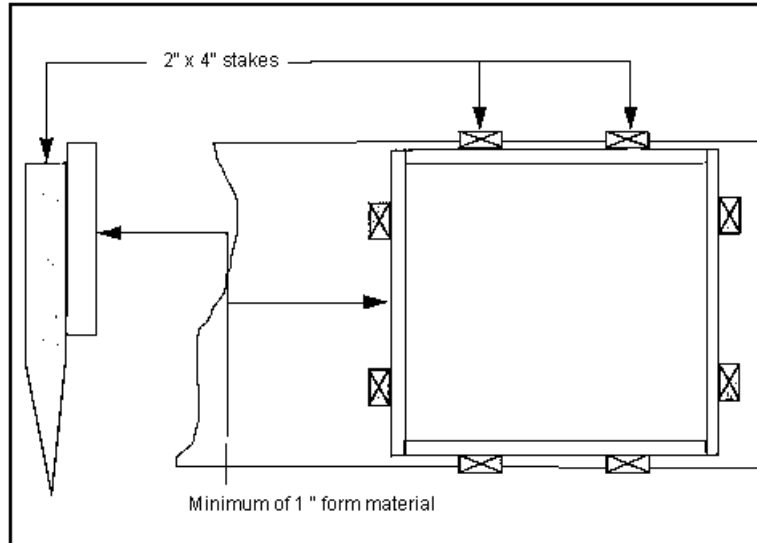

Figure 051-236-1166-2  
Wood-slab-form components

- a. Construct the formwork. Measure and mark the side-form material to the required lengths.
    - (1) Make two pieces the actual length of the slab and two pieces length of the slab plus two times the thickness of the material.
    - (2) Nail the form sides together at the corners.
  - b. Place and secure the formwork.
    - (1) Place the formwork at the specified location.
    - (2) Square the forms by using the diagonal method.
    - (3) Drive the stakes at all the corners and approximately 3 feet along the entire perimeter of the form.
    - (4) Level the formwork, then nail the forms to the stakes.
  - c. Cut and place polyethylene plastic in the bottom of the form as a vapor barrier.
3. Construct a steel-form slab (Figure 051-236-1166-3).

## Performance Steps

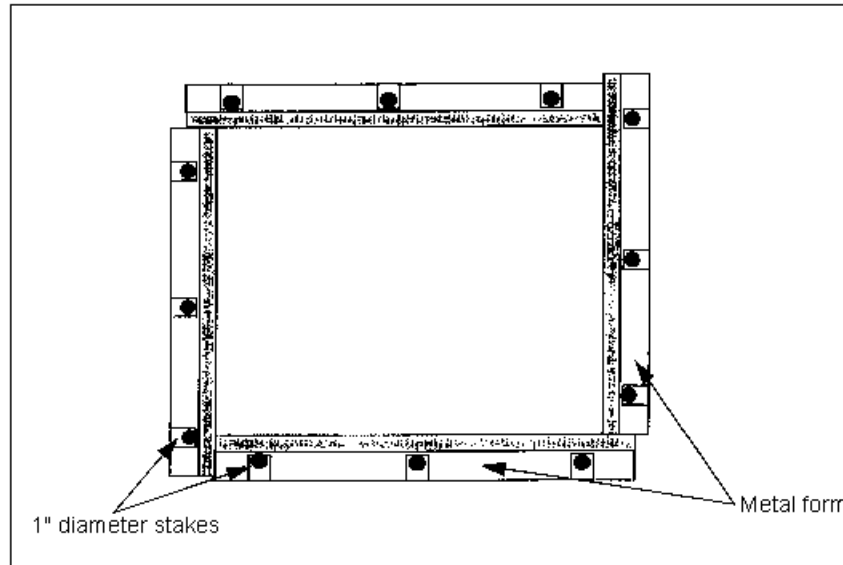

Figure 051-236-1166-3  
steel-slab-form components

- a. Place the forms in position at the specified location.
  - b. Square the forms by using the diagonal method.
  - c. Secure the forms in place by driving 1-inch diameter stakes in the slots provided on the forms.
  - d. Recheck the forms to ensure that they are level and square.
  - e. Cut and place polyethylene plastic in the bottom of the form as a vapor barrier.
4. Install reinforcing material.
- a. Install reinforcing bars.
    - (1) Cut the rebar 4 inches shorter than the dimensions of the slab.
    - (2) Place the high chairs inside the formwork to support the rebar grid.
    - (3) Ensure that there are at least 2 inches of space between the rebar, the formwork, and the ground.
    - (4) Tie the rebar at the intersections to form a grid to the high chairs.
  - b. Install welded wire mesh.
    - (1) Cut the wire mesh to 4 inches less than the dimension of the formwork.
    - (2) Place the high chairs inside the formwork.
    - (3) Position the wire mesh on top of the high chairs and secure with tie wire, ensuring that there are at least 2 inches between the wire and any formwork.
  - c. Install reinforcement bars and welded wire mesh.
    - (1) Install the reinforcement bars in the form as previously discussed.
    - (2) Install the wire mesh on top of the reinforcement bars.
    - (3) Tie the wire mesh to the reinforcement bars (051-236-1166-4).

**Performance Steps**

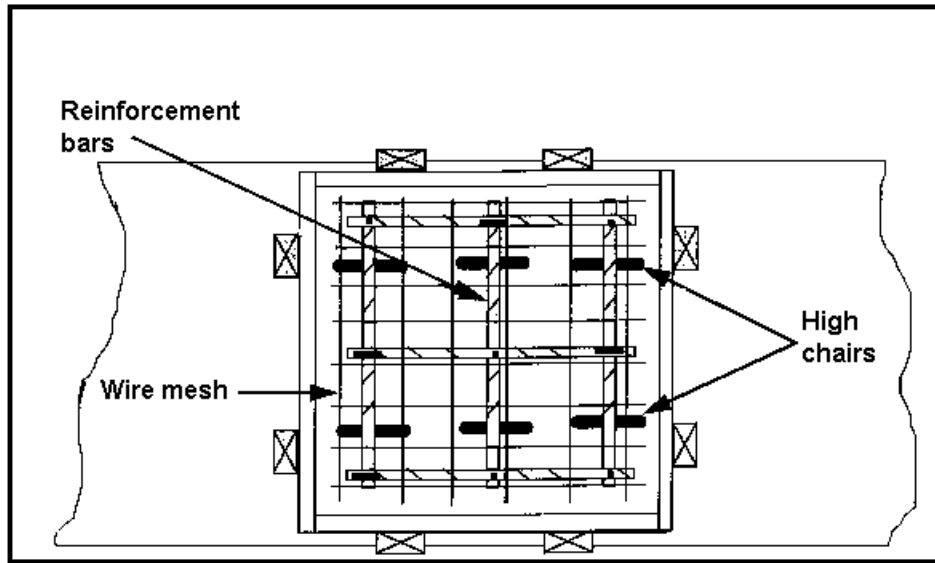

Figure 051-236-1166-4  
Steel reinforcing material

**Evaluation Preparation:** Setup: Provide the soldier with the items listed in the conditions. Brief soldier: Tell the soldier to identify components of a concrete-slab form, construct a concrete-slab form, and install reinforcing material according to FM 5-428. Perform all operations without damage to equipment and environment and without injury to personnel.

**Performance Measures**

1. Identified the components of a concrete-slab form.
2. Constructed a wooden-form slab.
3. Constructed a steel-form slab.
4. Installed reinforcing material.

**Results**

P	F
P	F
P	F
P	F

**Evaluation Guidance:** Score the soldier a GO if all steps are passed (P). Score the soldier a NO-GO if any step is failed (F). If the soldier fails any step, show him how to do it correctly.

**References**

**Required**  
FM 5-428

**Related**

## Subject Area 14: Concrete Placement

**PERFORM A SLUMP TEST ON CONCRETE****051-236-1167**

**Conditions:** As a carpentry and masonry specialist in a field environment, given Field Manual (FM) 5-426, a metal mold, a tamping rod, a tape measure, and concrete samples.

**Standards:** Performed a slump test on concrete samples that made up test specimens according to Appendix A of FM 5-426.

**Performance Steps**

**PURPOSE OF A SLUMP TEST:** This test measures consistency characteristics in the workability of concrete. A specific amount of slump is necessary to gain the workability for an intended condition and method of application. A stiff mix has a low slump and is difficult to place when extensive reinforcing steel is used. However, it may be desirable in another application such as placing a concrete slab on an unlevelled grade. A more fluid mix may be used for applications where the concrete must envelop extensive reinforcing units; therefore, the concrete must flow in and around the entire unit during placement. A slump test is inaccurate if applied to concrete containing aggregate larger than a "2." The higher the number attained on a slump test, the more fluid the concrete will be.

1. Perform a test specimen. Ensure that concrete samples making up the test specimens are representative of an entire batch.
  - a. Take all concrete samples at the mixer or, if you are using ready-mixed concrete, take concrete samples during discharge from the transportation vehicle.
  - b. Start taking these samples by repeatedly passing a scoop or pail through the concrete stream at the beginning of the discharge and continuing until the entire batch discharges.
  - c. Take at least five samples from different portions of the pile and thoroughly mix them to form the test specimen.
2. Perform test procedures.
  - a. Dampen the mold and place it on a flat, moist, nonabsorbent, firm surface.
  - b. Fill the mold immediately with three equal layers of a concrete specimen.
  - c. Rotate each scoopful of the concrete around the top edge of the mold as the concrete slides from it.
  - d. Tamp each layer 25 strokes with the tamping rod, distributing the strokes uniformly over the cross section of the mold and penetrating the underlying layer.
  - e. Strike off the surface with a trowel, after tamping the top layer, so that the concrete fills the mold exactly.
  - f. Lift the mold, carefully and without delay, straight up from the concrete and place it beside the specimen.
3. Perform a slump measurement.
  - a. Place the tamping rod across the top of the mold.
  - b. Measure the distance between the bottom of the rod and the displaced original center of the top surface of the specimen. This measurement is the slump of the concrete. Refer to Table 051-236-1167-1 and Figure 051-236-1167-1.
  - c. This measurement is the slump of the concrete.

**Performance Steps**

<b>Concrete Construction</b>	<b>Slump, in Inches</b>	
	<b>Maximum*</b>	<b>Minimum*</b>
Reinforced foundation walls and footing	3	1
Plain footing, caissons, and substructure walls	3	1
Beam and reinforced walls	4	1
Building columns	4	1
Pavement and slabs	3	1
Mass concrete	2	1
NOTE: 1 inch = 25 mm *May be increased 1 inch for consolidation by methods such as rods and spades.		

Table 051-236-1167-1  
Slump test for various types of construction

Performance Steps

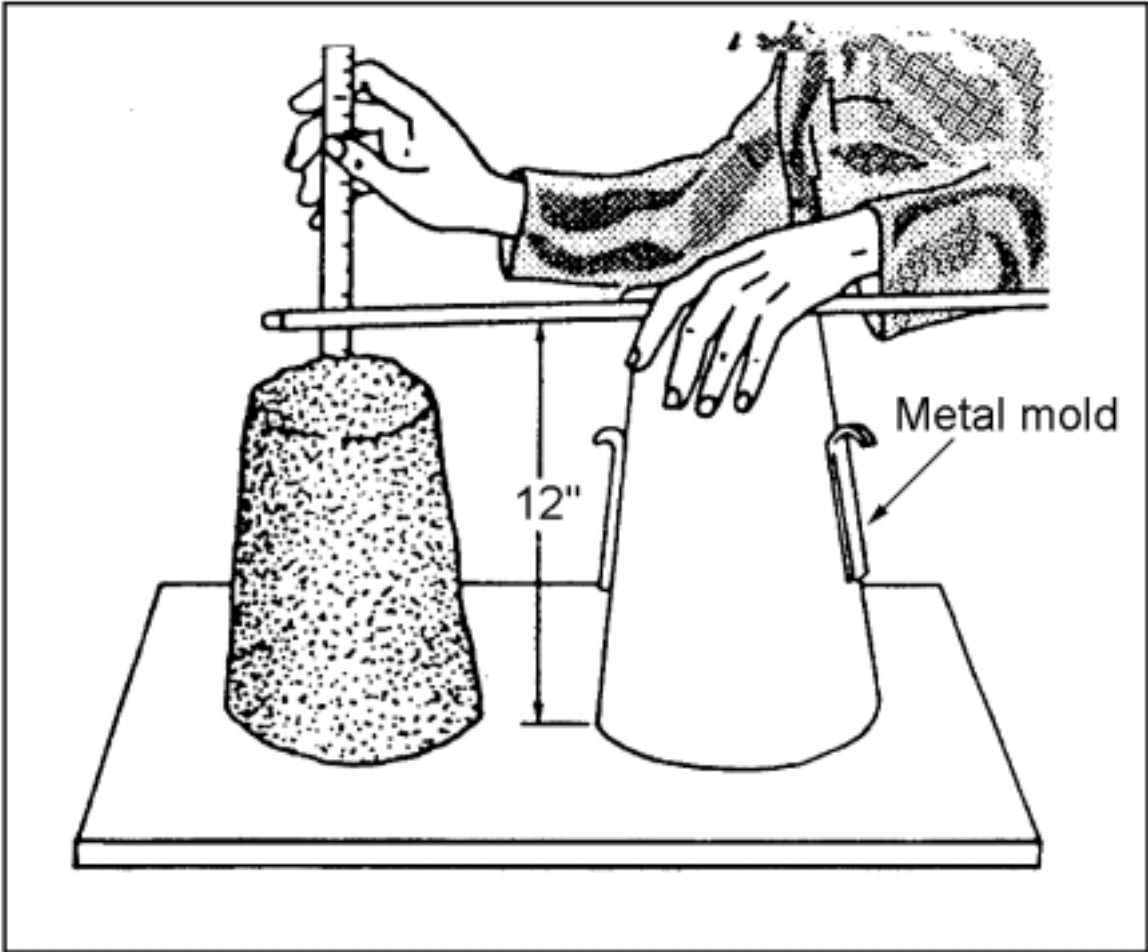

Figure 051-236-1167-1  
Measuring slump

**Evaluation Preparation:** Setup: Provide the soldier with the items listed in the conditions. Brief soldier: Tell the soldier to perform a slump test according to Appendix A of FM 5-426.

Performance Measures	Results
1. Performed a test specimen.	P F
2. Performed test procedures.	P F
3. Performed a slump measurement.	P F

**Evaluation Guidance:** Score the soldier GO if all steps are passed (P). Score the soldier NO-GO if any steps is failed (F). If the soldier fails any step, show him how to do it correctly.

**References**  
**Required**  
FM 5-426

**Related**



## PLACE CONCRETE

**051-236-1168**

**Conditions:** As a carpentry and masonry specialist in a field environment, given a concrete form, mixed concrete, a square shovel, a rake, roller bug, hand floats, an edger, bull floats with handles, a darby, brooms, a hammer, a knee board, a jointer, oil, coveralls, gloves, goggles, hard hat, protection boots, and hearing protection.

**Standards:** Consolidated concrete to remove honeycombing; finished the concrete with a float so that water was not brought to the surface; finished the concrete with a trowel so that the surface was smooth, even, and free of marks and ripples; and edged the concrete so that no cracks or chips appeared on the edges.

### Performance Steps

**NOTE:** Use the following information to construct formwork for sidewalks, front walks, service walks, driveways, and concrete slabs.

1. Construct the formwork.
  - a. Install corner stakes at the four corners of the sidewalk and driveway and mark the grade levels and stretch lines.

**NOTE:** Driveways used for passenger cars should be at least 4 inches thick. Those used for trucks should be at least 5 inches thick. Reinforce driveways and slabs with wire mesh to prevent cracking.

**NOTE:** The slope across should be 1/8 inch to 1/4 inch to allow for water drainage. A slope of 1 inch in 12 feet is sufficient for front walk and service walk. Use a minimum cross slope of 1/4 inch per foot for water drainage on driveways and slabs.

- b. Drive the intermediate stakes to the line 4 feet on center.
- c. Snap the grade levels on the stakes and nail a form board to one side brace of the form board, if necessary.
- d. Nail the opposite end boards to the snapped lines. Cut the stakes flush with the top of the form boards. Brace the form boards, if necessary.
- e. Place spreader boards at intervals, as required.

**NOTE:** Remove the spreaders as the concrete is poured.

- f. Use a 2- by 4-inch strike board for the screeding operation.

2. Consolidate the concrete.
  - a. Place the concrete at the farthest point and work toward the source.
  - b. Spread and level the concrete to the desired depth of the form. Use a square head shovel or concrete rake. Spade the concrete along the forms to fill voids and honeycombing at the edges.
3. Screed the concrete.
  - a. Pull the screed forward with its top edge tilted slightly forward for the first pass.
  - b. Bring the screeder back at the starting point while sliding it back and forth in a sawing motion across the top of the forms. Always keep a little concrete in front of the straightedge to fill in low spots.
  - c. Keep the tops of the form clean and keep the straightedge against them.
  - d. After the second pass, slightly depress the large aggregates by using a jitterbug.
  - e. Continue until the concrete is at the correct level.

**NOTE:** Screeding may have to begin before concrete placement is completed.

**NOTE:** Use the jitterbug only on concrete with a low slump (1 inch or less). Using a jitterbug on concrete with a slump greater than 2 inches causes segregation. Never use a jitterbug to level the surface of a slab. Use a bull float for areas that can not be reached with a darby. Move the bull float forward and backward across the surface.

### Performance Steps

4. Finish the concrete with a float. Floating the concrete shortly after screeding and before any bleed occurs.
  - a. Use a darby along the edges, moving at a 90-degree angle to the edge of the slab.
  - b. Fill in all the spots along the edges.
  - c. Clean off the top of the forms and the existing slab edges.
5. Edge the slab. As the sheen of water begins to leave the surface, follow the side forms around the perimeter of the slab by using the edger. Use a pointing or margin trowel to cut the concrete away from the forms to a 1-inch depth. Run an edger back and forth along the forms until it produces a finished edge. Place the edger flat on the concrete surface and tilt it up slightly in the direction you move the tool. Edge the slab in this way along all side forms, isolation joints, and construction joints.
  - a. Keep the edge of the slab flat and true. Do not depress.

NOTE: The rounded concrete edge is less prone to chipping. The edger also densifies the surface along the form, where floats and trowels are less effective.

- b. After completing the edging, float around the edges of slab to knock down the ridges left by the edger.

6. Make contraction joints.
  - a. Mark the location of each joint on the concrete surface with a chalk line.
  - b. Rest a board on the side forms so it is parallel to the string line and at a right angle to the slab edges. This acts as a guide for the groover.

NOTE: The board must be at least 1 inch by 8 inches.

- c. Push the groover into the concrete. Move the groover forward while applying pressure to the back of it. After the joint is cut, turn the groover around and pull it back through the joint.

7. Hand float the edge of the slab.
  - a. Reach out as far as possible with a magnesium float.
  - b. Swing the float in the side arc.
    - (1) Keep the front edge of the float slightly above the surface of the slab to avoid digging into the concrete.
    - (2) Overlap the previous pass by about one-half the length of the float.
    - (3) Keep the pressure even on the toe and heel of the float.
    - (4) Ensure that the last pass is at a 90-degree angle to the edges of the slab.

8. Hand float the center of the slab.
  - a. Place knee boards on the slab.
  - b. Kneel on the boards to support your weight.
  - c. Use the same procedures as for floating the edges and float the center of the slab.

9. Edge the slab. Follow the same procedures as step 5.

10. Trowel the slab.
  - a. Begin troweling when the concrete has hardened enough to ensure that fine particles will not be worked to the surface.
  - b. Use knee boards and start at the center of the slab and work toward the edges.
  - c. Swing the steel trowel in a large arc, overlapping each swing by one-half the length of the trowel.

11. Add texture. Drag a damp, soft-bristled broom across the surface after troweling.

12. Cure the concrete.
  - a. Wet cure the concrete by covering the surface with wet burlap or wet sand. Wet sawdust, wet hay, or wet straw may be used, but may stain the concrete surface. Place the wet covering as soon as possible without marring the surface. Keep it wet at all times.
  - b. Prevent evaporation by covering the surface with plastic sheeting or waterproof paper. Place the covering as soon as possible without marring the surface. Plastic may leave a mottled surface color.

**Performance Steps**

- c. Prevent evaporation by spraying a liquid membrane-forming curing compound on the surface. Use a curing compound that does not permanently discolor the surface and does not interfere with subsequent liquid surface treatments.

**Evaluation Preparation:** Setup: Provide the soldier with the items listed in the conditions. Brief soldier: Tell the soldier to consolidate the concrete, finish the concrete with a float, finish the concrete with a trowel, and edge the concrete so that no cracks or chips appear on the edges.

<b>Performance Measures</b>	<b>Results</b>	
1. Constructed the formwork.	P	F
2. Consolidated the concrete.	P	F
3. Screeded the concrete.	P	F
4. Finished the concrete with a float.	P	F
5. Edged the slab.	P	F
6. Made contraction joints.	P	F
7. Hand floated the edge of the slab.	P	F
8. Hand floated the center of the slab.	P	F
9. Edged the slab.	P	F
10. Troweled the slab.	P	F
11. Added texture.	P	F
12. Cured the concrete.	P	F

**Evaluation Guidance:** Score the soldier a GO if all steps are passed (P). Score the soldier a NO-GO if any step is failed (F). If the soldier fails any steps, show him how to correctly do it.

**References**

**Required**  
FM 5-428

**Related**

Subject Area 15: Masonry Structure

**CONSTRUCT A MASONRY WALL**

**051-236-1146**

**Conditions:** As a carpentry and masonry specialist in a field environment, given Field Manual (FM) 5-428, construction prints and specifications, a carpenter's tool kit, a masonry and concrete finisher's tool kit, a mortar mix design, a completed concrete foundation, 8- by 8- by 16-inch concrete masonry units, sand, masonry cement, lime, a water hose, a water source, anchor bolts, a 1-cubic foot measuring box, a concrete mixer, a wheel barrow, a shovel, a calculator, goggles, gloves, hearing protection, a hard hat, paper, and a pencil.

**Standards:** Fabricated masonry walls to within +/- 1/8 inch of the specifications according to FM 5-428. Placed anchor bolts to within +/- 1/4 inch.

**Performance Steps**

1. Lay the first course of blocks.
  - a. Step 1. Use a chalked snap line to accurately mark the footing and align the blocks.
  - b. Step 2. Replace the loose blocks with a full bed of mortar under the bottom edges.
  - c. Step 3. Use care to position and align the corner block first (Figure 051-236-1146-1).

## Performance Steps

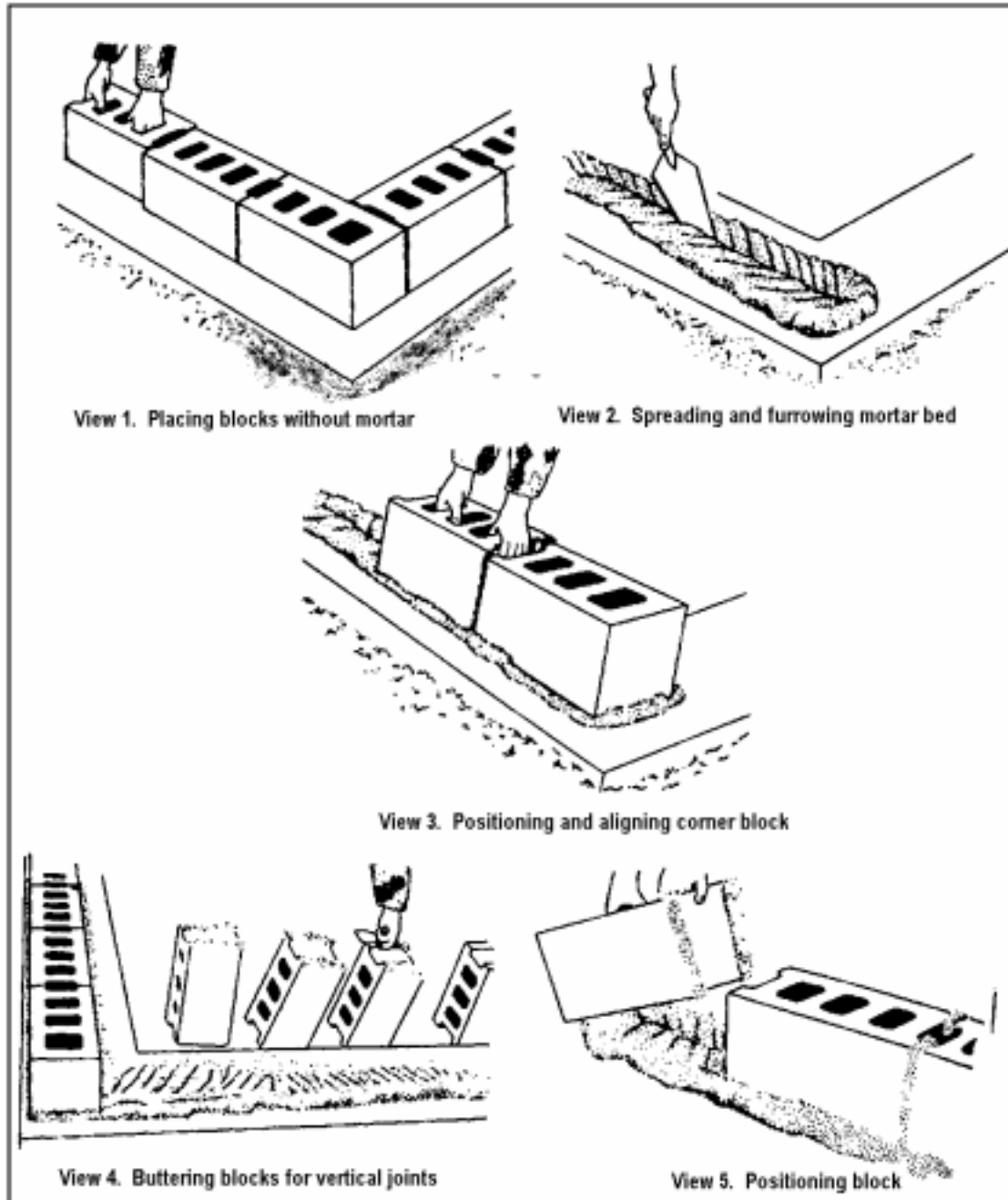

Figure 051-236-1146-1  
Laying first course of blocks for a wall

- d. Step 4. Lay the remaining first course of blocks with the thicker end up to provide a larger mortar-bedding area.
- e. Step 5. Apply mortar to the block ends for the vertical joints by placing several blocks on end and buttering them all in one operation. Make the joints  $\frac{3}{8}$  inch thick.

**Performance Steps**

- f. Step 6. Place each block in its final position and push it down vertically into the mortar bed and against the previously laid block to obtain a well-filled vertical mortar joint.
- g. Step 7. Lay three or four blocks, then use a mason's level as a straightedge to check for correct block alignment.
- h. Step 8. Use the level to bring the blocks to the proper grade and make them plumb by tapping them with a trowel handle (Figure 051-236-1146-2).

## Performance Steps

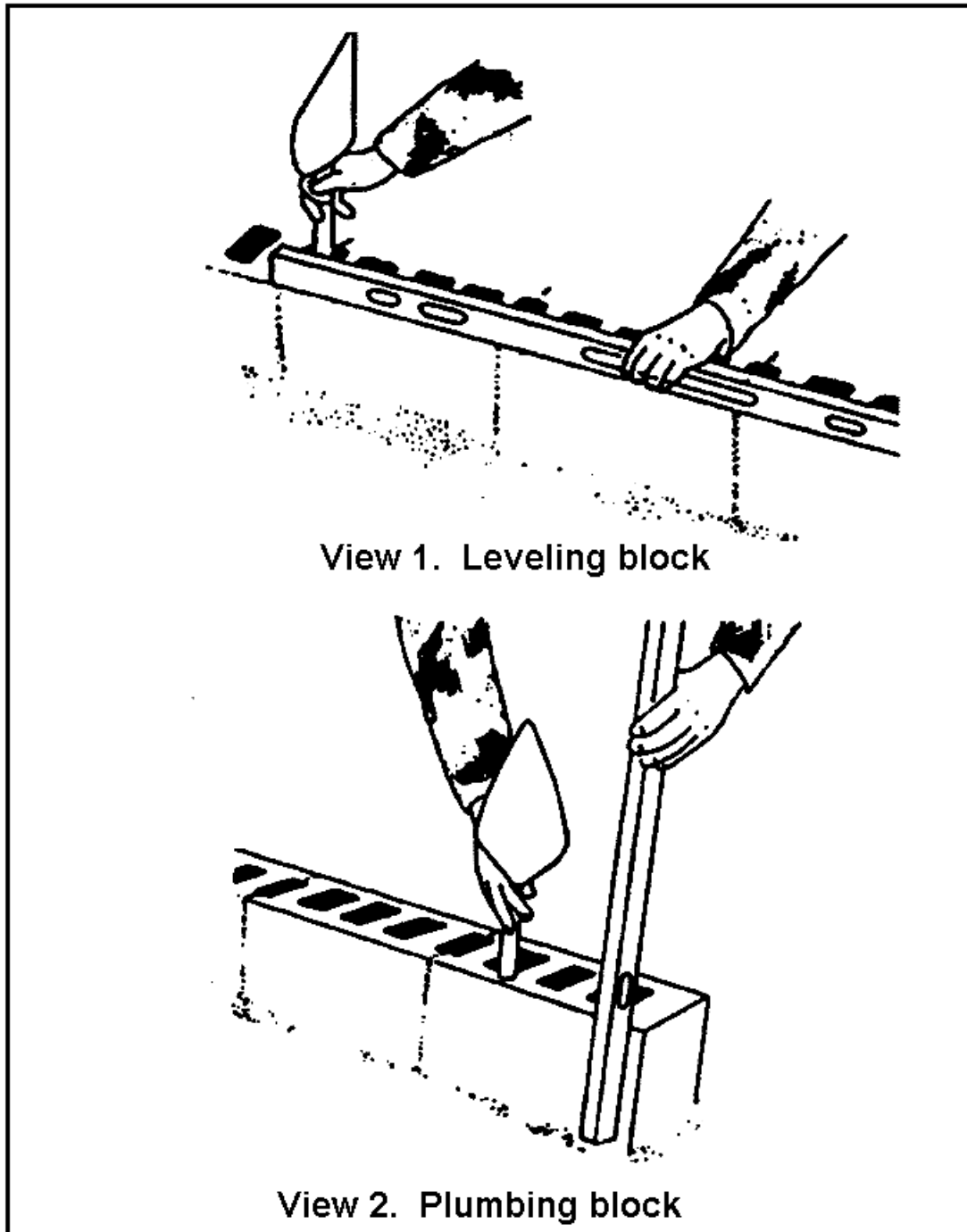

Figure 051-236-1146-2  
Leveling and plumbing first course of blocks for a wall

- i. Step 9. Lay out the first course of concrete masonry very carefully, ensuring that it is properly aligned, level, and plumb. This ensures that succeeding courses and the final wall are both straight and true.

### Performance Steps

2. Lay the corner blocks.
  - a. Step 1. Move back each course one-half block.
  - b. Step 2. Apply mortar only to the tops of the blocks of the horizontal joints already laid.
  - c. Step 3. Apply mortar to the vertical joints, either to the ends of the new block previously laid, or both blocks, to ensure that the joints are well-filled.
  - d. Step 4. Lay each course at the corner. Check it with a level for alignment and levelness, ensuring that it is plumb.
  - e. Step 5. Use care to check each block with a level or straightedge to ensure that the block faces are in the same plane and to ensure true, straight walls. A story or course pole, which is a board with markings 8 inches apart, helps to accurately determine the top of each masonry course.
  - f. Step 6. Check the horizontal block spacing by placing a level diagonally across the corners of the blocks (Figure 051-236-1146-3).



Performance Steps

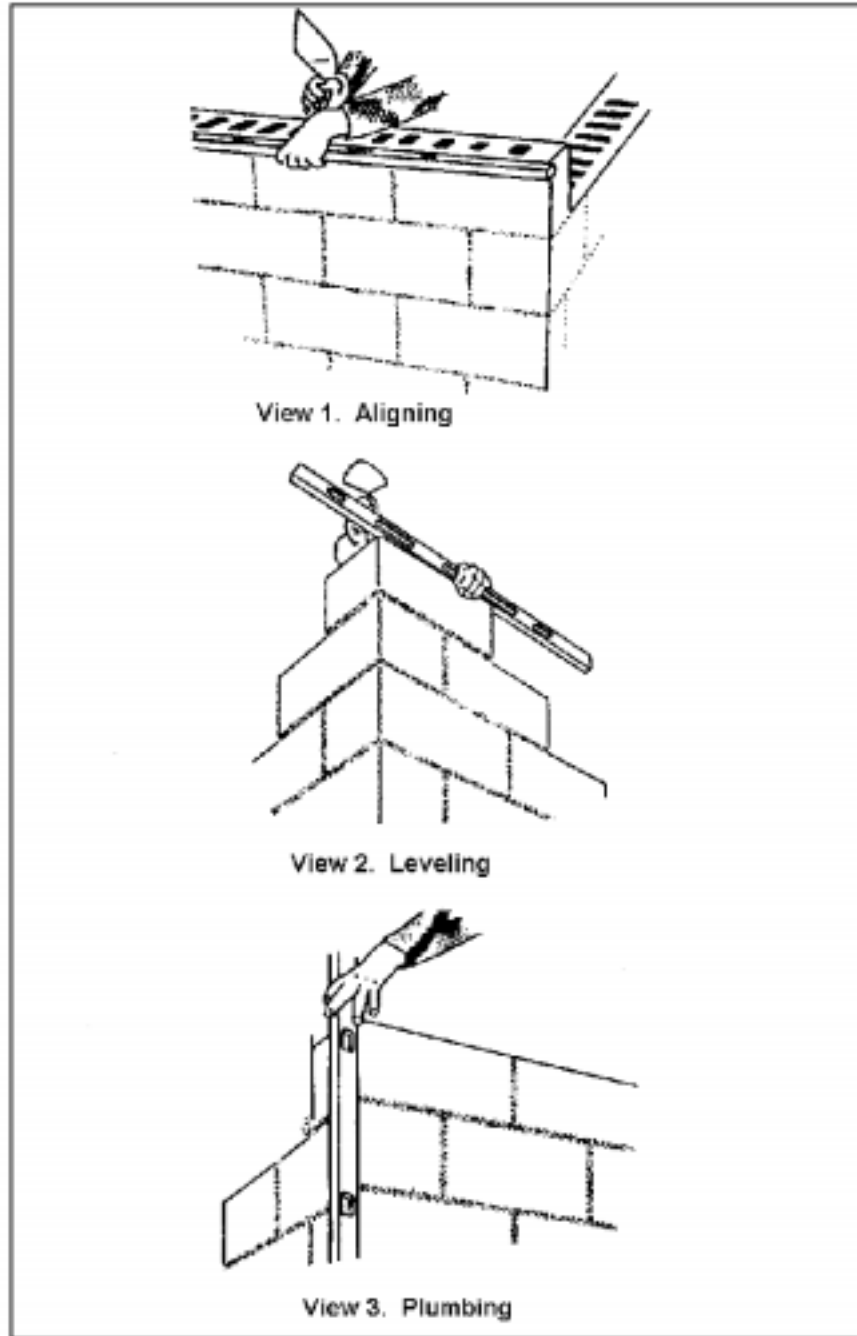

Figure 051-236-1146-3  
Checking each course at the corner

3. Lay blocks between the corners.
  - a. Step 1. Stretch a mason's line along the exterior block edges from corner to corner for each course.

**Performance Steps**

- b. Step 2. Lay the top outside edge of each new block to the mason's line (FM 5-428, Figure 8-11).
  - (1) Tip the block slightly toward you so that you can see the edge of the course below.
  - (2) Place the lower edge of the new block directly on the edges of the blocks comprising the course below.
  - (3) Make all the final position adjustments while the mortar is soft and plastic. Any adjustments made after the mortar stiffens will break the mortar bond and allow water to penetrate the joints.
  - (4) Level each block and align it to the mason's line by tapping it lightly with a trowel handle.

4. Lay control joints.

- a. Caulk the joints if they are exposed to either the weather or to view.
- b. Rake the mortar (after it is stiff) out to a depth of about 3/4 inch to make a recess for the caulking compound.

NOTE: Refer to FM 5-428, Figure 8-17.

- c. Make a second type of control joint (if needed) by inserting building paper or roofing felt into the block-end cores, extending the full height of the joint.
- d. Cut the paper or felt to convenient lengths, wide enough to extend across the joint. Use control-joint blocks, if available (Figure 051-136-1146-4).

Performance Steps

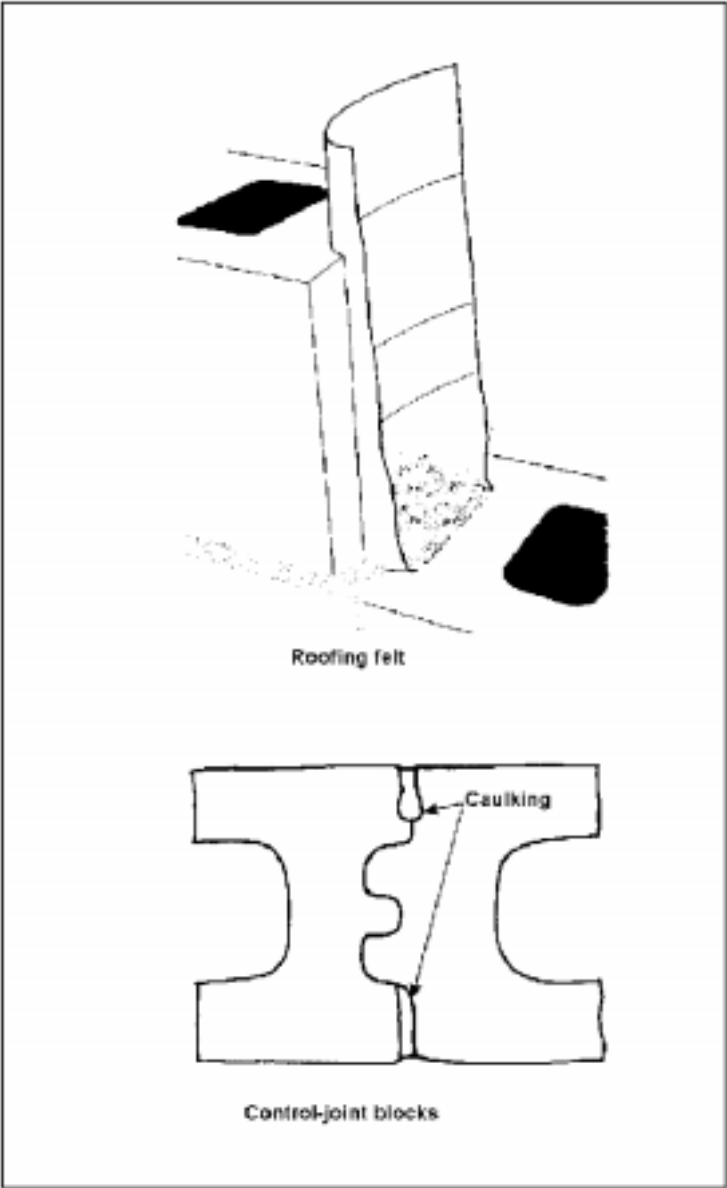

Figure 051-236-1146-4  
Control joints made of roofing felt or control-joint blocks

**Evaluation Preparation:** Setup: Provide the soldier with the list of items in the conditions. Brief soldier: Tell the soldier to fabricate masonry walls to within +/- 1/8 inch of the specifications.

**Performance Measures**

1. Laid the first course of blocks.
2. Laid the corner blocks.
3. Laid blocks between the corners.

**Results**

P	F
P	F
P	F

**Evaluation Guidance:** Score the soldier GO if all steps are passed (P). Score the soldier NO-GO if any step is failed (F). If the soldier fails any step, show him how to do it correctly.

**References**

**Required**  
FM 5-428

**Related**

## Subject Area 16: Planning

**PREPARE A MATERIALS TAKE-OFF LIST****051-236-1183**

**Conditions:** As a carpentry and masonry specialist in a field environment, given Field Manual (FM) 5-426, construction prints and specifications, a calculator, paper, and a pencil.

**Standards:** Prepared a carpentry materials takeoff list by calculating and listing, by type and size, the total quantity of material required based off the construction prints.

**Performance Steps**

1. Prepare a materials takeoff list. The materials takeoff list is the first step leading to the preparation of a bill of materials (BOM). It is a listing of all parts of the building, taken from the plans, usually by tallying and checking off the items indicated on the drawings and specifications.
2. Plan for the substructure of a 20- by 40-foot theater of operation (TO) building (Figure 051-236-1183-1). Extract information from this construction drawing and write the information in the columns on the materials takeoff list. Assume the available lengths of lumber are 8, 10, and 12 feet. This list identifies all parts of the building, starting with its base and working upward.

**Performance Steps**

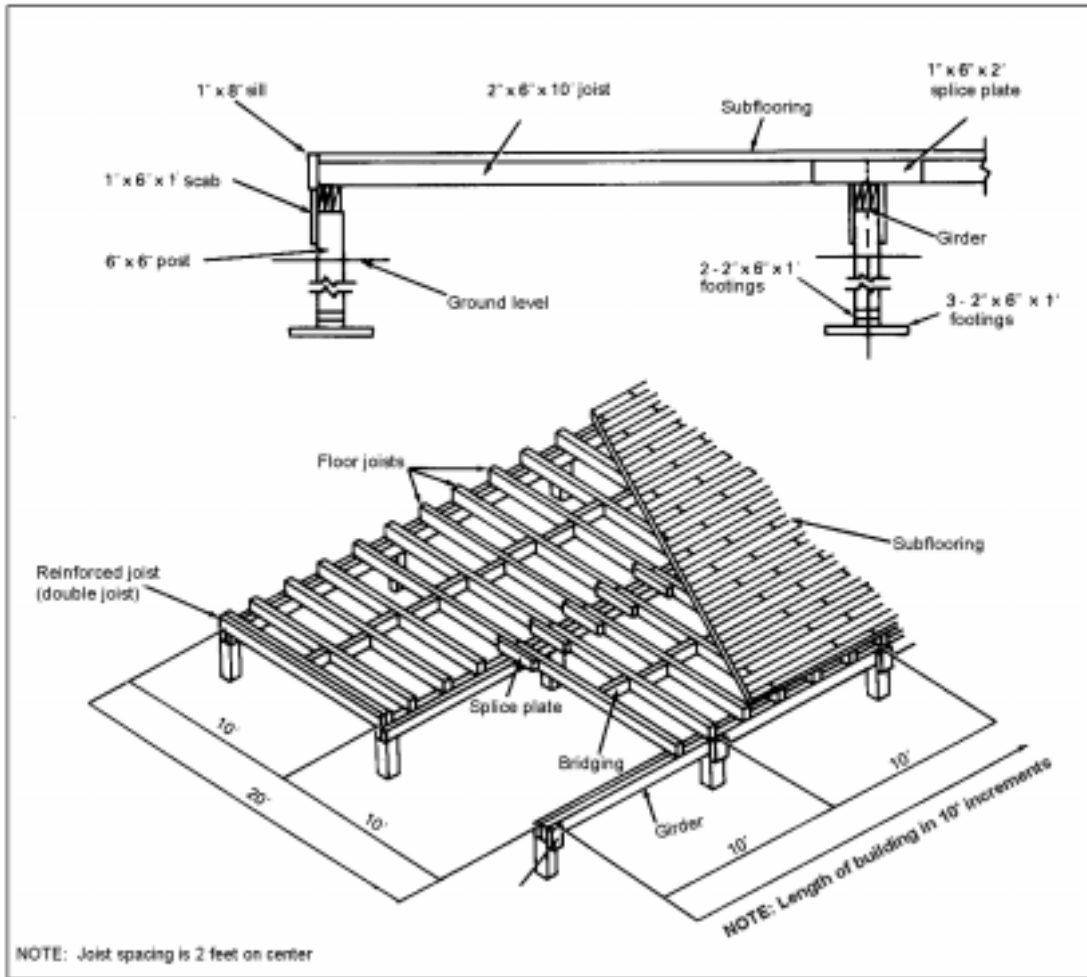

Figure 051-236-1183-1  
20-foot wide building substructure

- a. Look at the first and second columns of the materials takeoff list (Table 051-236-1183-1). The first column gives the item (footers), the next column gives the number of pieces needed (45) to make up the item.



**Performance Steps**

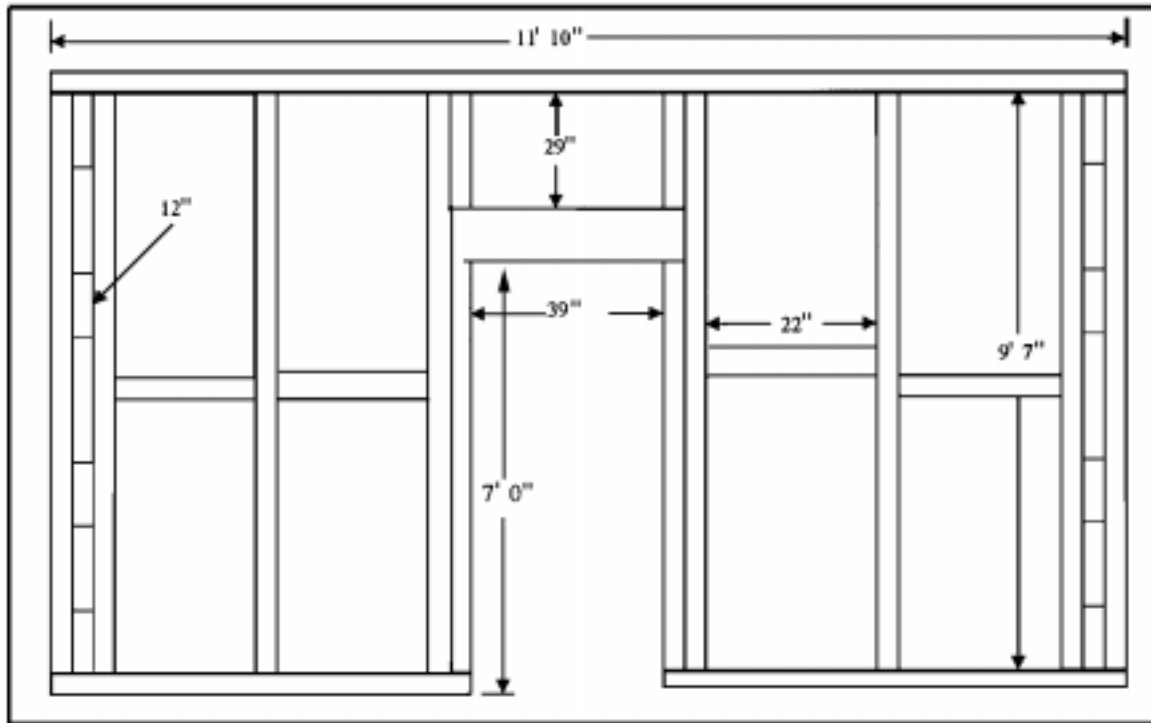

Figure 051-236-1183-2  
Wall section with door opening

**Evaluation Preparation:** Setup: Provide the soldier with the items listed in the conditions. Brief soldier: Tell the soldier to prepare a materials takeoff list. The total quantity of material required based off the construction prints.

**Performance Measures**

1. Prepared a materials takeoff list.
2. Planned for the substructure of a 20- by 40-foot TO building.

**Results**

P F  
P F

**Evaluation Guidance:** Score the soldier a GO if all steps are passed (P). Score the soldier a NO-GO if any step is failed (F). If the soldier fails any step, show him how to do it correctly.

**References**

**Required**  
FM 5-426

**Related**



## Skill Level 2

## Subject Area 17: Wood Structures

**INSTALL DOORS AND WINDOWS****051-236-2109**

**Conditions:** As a carpentry and masonry specialist in a field environment, given Field Manual (FM) 5-426, construction prints and specifications, a completed wood structure, prefabricated doors and windows, wedges, wood screws, a carpenter's tool kit, sawhorses, an extension ladder, a step ladder, goggles, gloves, hearing protection, a hard hat, paper, and a pencil.

**Standards:** Installed doors and windows according to FM 5-426 and the construction prints and specifications. Ensured that all wood members were plumb and installed the hinges with total gain being no more than 1/16 inch larger than the hinge. Performed all operations without causing damage to equipment or the environment and without injury to personnel.

**Performance Steps**

1. Install doors (Figure 051-236-2109-1).

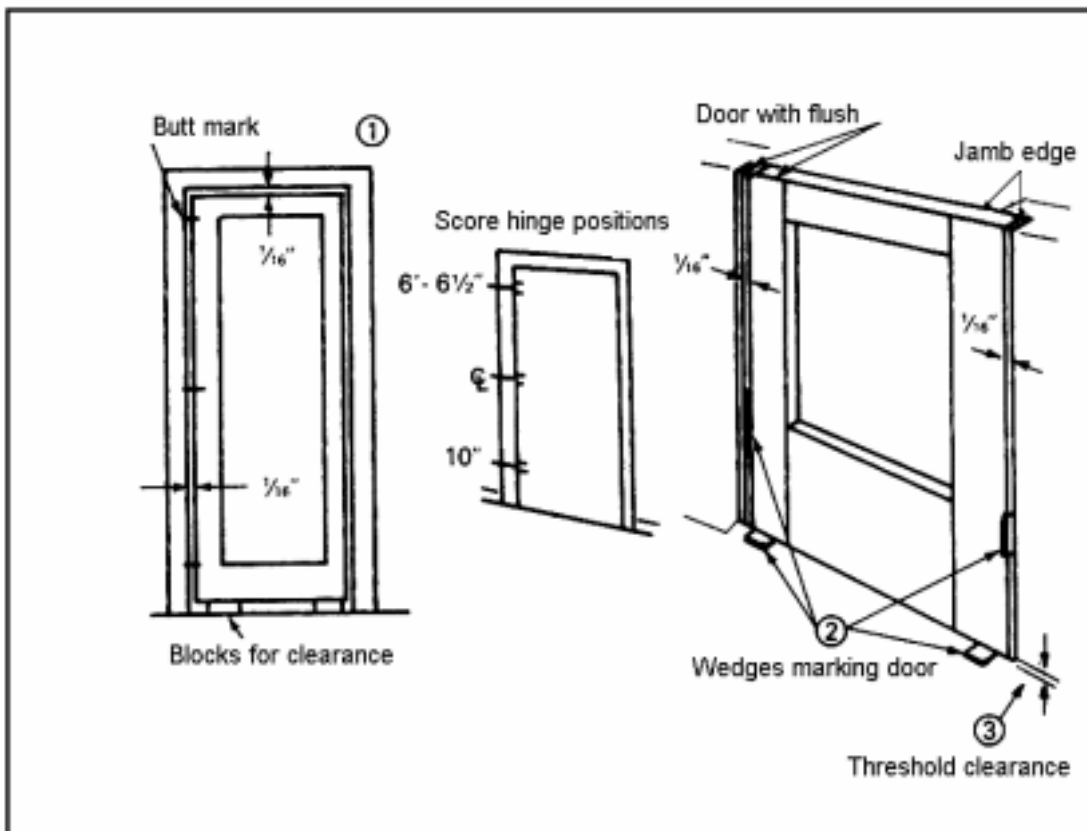

Figure 051-236-2109-1  
Hang a door

**Performance Steps**

- a. Prepare the opening by cutting off the stile extension, if any.
  - b. Plane the edges of the stile until the door fits tightly against the hinge side and clears the lock side of the jam by about 1/16 inch.
  - c. Ensure that the top fits squarely to the rabbeted recess and that the bottom swings free of the finished floor by about 1/2 inch.
  - d. Ensure that the lock stile of the door is beveled slightly so the edge of the stile will not strike the edge of the doorjamb.
  - e. Ensure that proper clearance has been made. Tack the door into position in the frame and wedge it at the bottom.
  - f. Mark the hinge position with a sharp-pointed knife on the stile and the jamb. Place the hinge position on the stile slightly higher than the lower door rail and slightly lower than the upper door rail. Mark the door-rail tensions that are housed in the stile to avoid cutting out parts of them. Mark the--
    - (1) Location of the butt on the jamb.
    - (2) Location of the butt on the door.
    - (3) Thickness of the butt on both the jamb and the door.
2. Install door butts (or hinges) (Figures 051-236-2109-2 and 051-236-2109-3).

Performance Steps

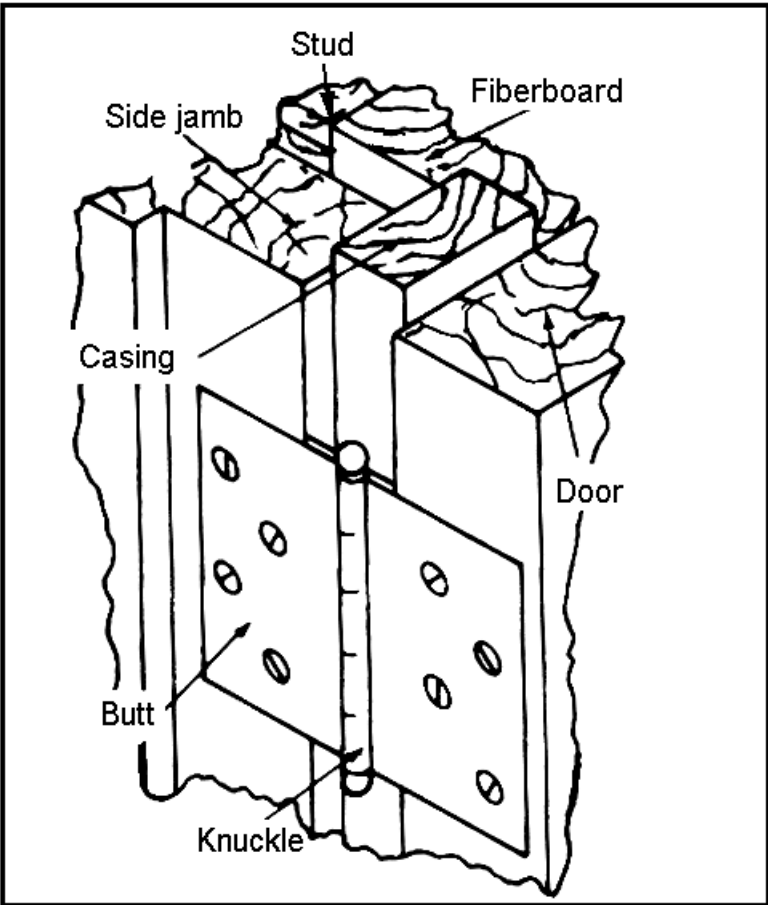

Figure 051-236-2109-2  
Door butt (hinge)

## Performance Steps

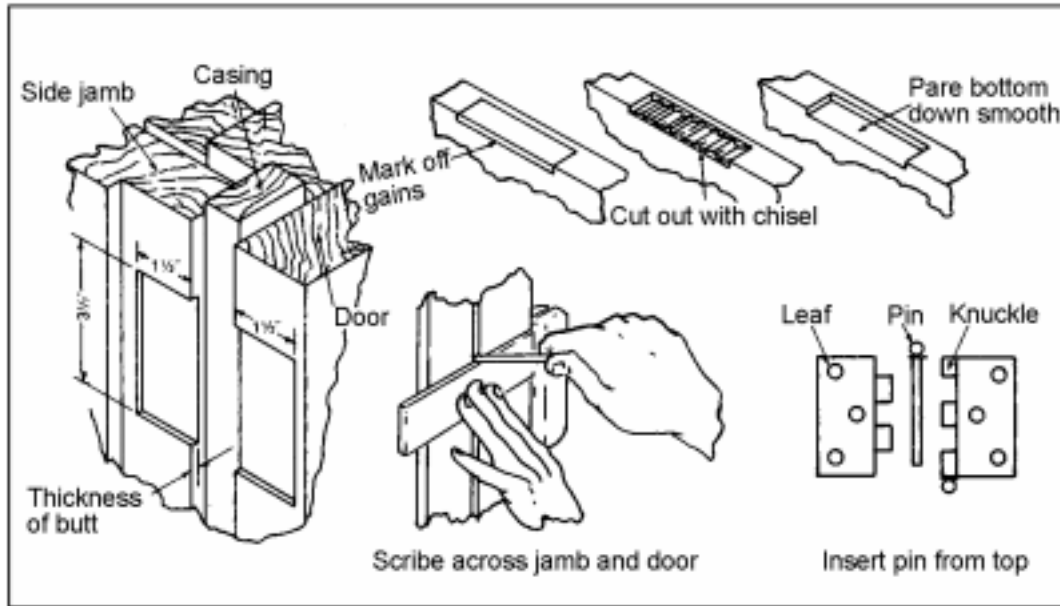

Figure 051-236-2109-3  
Install door butts (hinges)

- a. Use three butt hinges on all full-length doors to prevent warping and sagging.
  - b. Place the butts and mortise with the utmost accuracy so that the door will open and close properly.
  - c. Ensure that the butt pins project more than half its thickness from the casing.
  - d. Use the butt as a pattern; mark the butt dimension on the edge and face of the door.
  - e. Use a 1-inch chisel to cut out the marked areas (called gains) on the doorjamb and door to fit the butt.
  - f. Test the gains. The butts must fit snugly and exactly flush with the edge of the door and the face of the jamb.
  - g. Screw half of each of the butt joints on the door and the other three parts on the jamb. Place the butts so that the pins are installed from the top when the door is hung.
  - h. Set the door against the frame so that the two halves of the top butt engage. Insert the top pin. Engage and insert pins in the bottom and center butt.
3. Install door stops.
    - a. Place temporary door stops until the door is hung (Figure 051-236-2109-4).

## Performance Steps

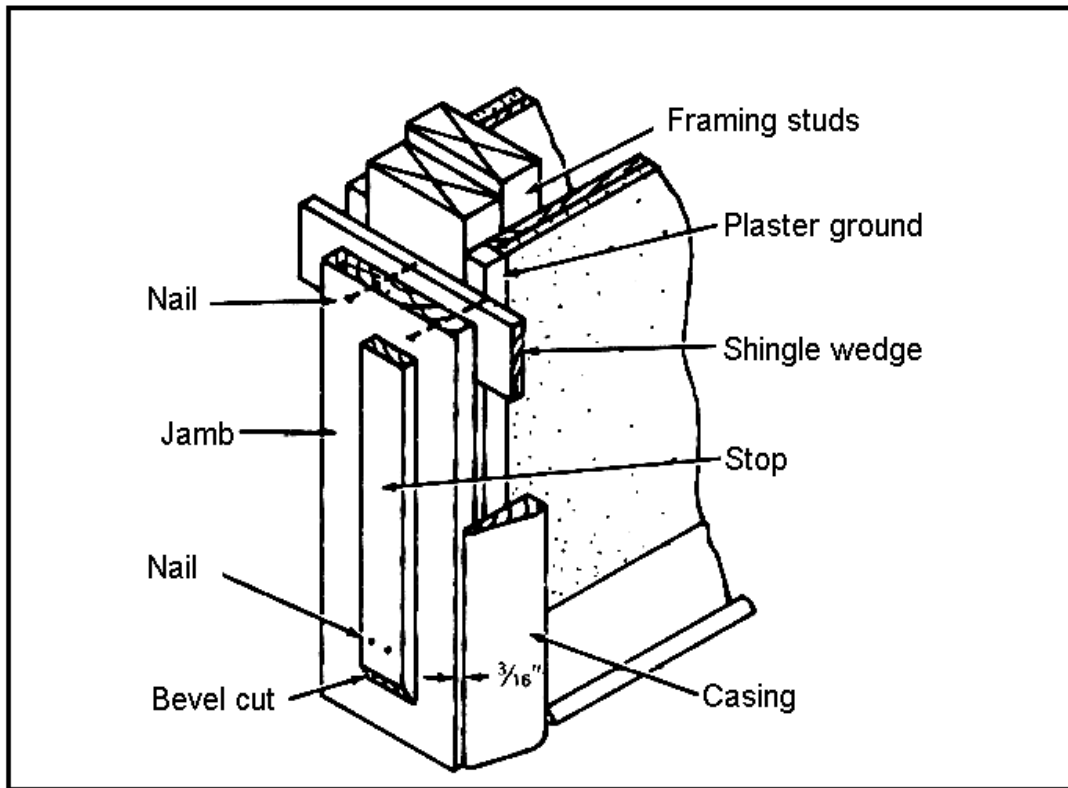

Figure 051-236-2109-4  
Door trim and stop

NOTE: Stops for the door in a single-piece jamb are generally 1/2 inch thick and 2 inches on the side and is installed after the butt-joint junction of the side and head jambs. Cut a 45-degree bevel at the bottom of the stop about 1 or 1 1/2 inches above the finished floor to eliminate dirt pockets.

4. Finish the door trim (casing). Ensure that the casing is set back 1/4 inch from the faces of the jambs all around.
  - a. Fit the miter joints properly by starting at the top and working toward the bottom.
  - b. Use 4d finishing nails along the jamb side and 6d or 8d case nails along the outer edge of the casing.
  - c. Set the nail heads about 1/8 inch below the surface of the wood with a nail set.
  - d. Apply the casing for the other side and then the head casing.
5. Install the locks (Figure 051-236-2109-5).

## Performance Steps

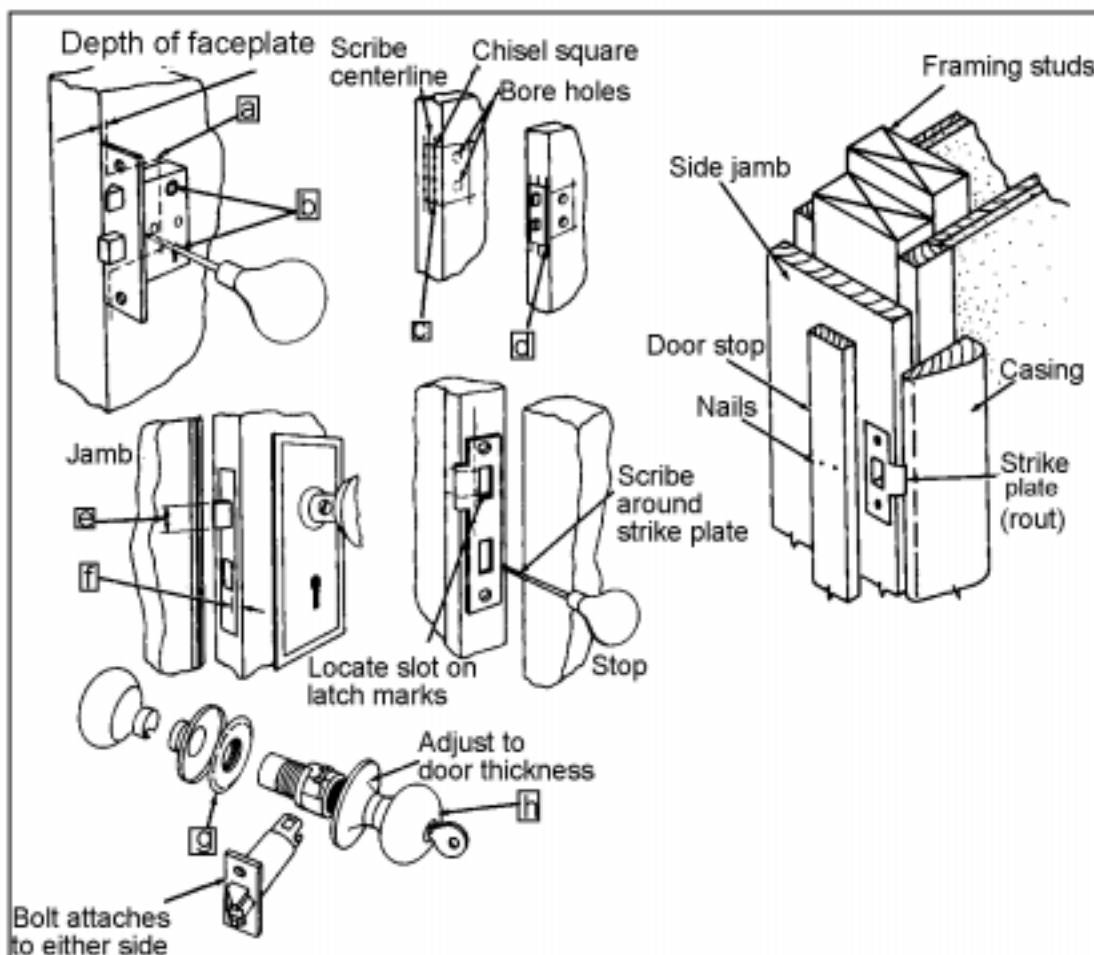

Figure 051-236-2109-5  
Install the lock and the strike plate

- a. Mark the position of the lock on the lock stile (36 inches from the floor level).
  - b. Hold the case of the mortise lock on the face of the lock stile. With a sharp knife, mark off the area to be removed from the edge of the stile that is to house the entire case.
  - c. Mark the position of the door knob rub and the position of the key.
  - d. Mark the position of the strike plate on the jamb.
  - e. Bore out the wood to house the lock and the strike plate and mortises.
  - f. Clear and install the lock set. Ensure that the strike plate is flush or slightly below the face of the door jamb.
6. Install the windows and strike plate. If there are no holes previously drilled in the flange, drill them.
    - a. Place three holes in the flange on each side of the window, one in each corner (top and bottom) and one approximately in the center.
    - b. Place a hole in the center of the top and bottom flange.
- NOTE: There will be a total of eight holes in the entire flange.
- c. Lift the window in place. Run a screw into one of the top corners.
  - d. Plumb the window and place a screw in the opposite top corner.
  - e. Work your way around the perimeter of the window and run screws in the remaining holes.

**Evaluation Preparation:** Setup: Provide the soldier with the items listed in the conditions. Brief soldier: Tell the soldier to install doors and windows. Have the soldier install doors and windows according to FM 5-426, the construction prints, and specifications. Perform all operations without causing damage to equipment or the environment and without injury to personnel.

<b>Performance Measures</b>	<b>Results</b>	
1. Installed doors.	P	F
2. Installed door butts (or hinges).	P	F
3. Installed door stops.	P	F
4. Finished the door trim (casing).	P	F
5. Installed the locks and strike plate.	P	F
6. Installed the windows.	P	F

**Evaluation Guidance:** Score the soldier GO if all steps are passed (P). Score the soldier NO-GO if any step is failed (F). If the soldier fails any step, show him how to do it correctly.

#### **References**

**Required**  
 FM 5-412  
 FM 5-426

#### **Related**

Subject Area 18: Sawmill Operations (RC)

**SET UP/OPERATE A TRAILER-MOUNTED SAWMILL (RESERVE COMPONENT [RC])**

**051-236-2114**

**Conditions:** As a carpentry and masonry specialist in a field environment, given a trailer-mounted sawmill, a pioneer tool set, a towing vehicle, a power unit, planks of timber, a jack, braces, a sawdust conveyor, steel bars, rope, logs, safety goggles, and Field Manual (FM) 5-488. These items must be available to accomplish the task.

**Standards:** Set up a trailer-mounted sawmill with a crew of 12 to 15 soldiers within one hour. Dug a hole about 6 inches deep in front of each wheel (on level ground) so that when the sawmill was leveled, 50 percent of its weight was removed from the tires. Placed a plank of timber underneath each leg. Made several short travels of the carriage and increased to full-length travels before attempting to take on the first log.

**Performance Steps**

1. Set up the sawmill.
  - a. Place the trailer-mounted unit within 3 feet of its desired position, lengthwise.
  - b. Dig a hole about 6 inches deep in front of each wheel (on level ground) so that when the sawmill is leveled, 50 percent of its weight will be removed from the tires.
  - c. Pull the unit forward to fit the holes.

**NOTE:** Ensure that the holes are not so deep that the sawdust conveyor rests on the ground when the unit is in the holes.

- d. Unhitch the towing vehicle from the sawmill.
  - e. Place the power unit near the sawmill.
2. Level the sawmill.
  - a. Place the two center legs of the sawmill down first and level the sawmill crosswise at this point.
  - b. Place the two legs of the sawmill on the log end into the down position, and level.
  - c. Lower the two legs on the lumber end and allow just enough tension to give adequate support.
  - d. Slide the carriage forward so the crank can be used to adjust the legs of the sawmill.
  - e. Ensure that some support, such as a plank of timber, is placed on the ground underneath each leg of the sawmill to prevent it from settling into the soil as operations proceed.
3. Brace the sawmill. Secure a brace from the frame of the sawmill to a stake driven in the ground or secure a brace to the power unit in order to compensate for drive-belt tension.
4. Set up the sawdust conveyor.
  - a. Set up the sawdust chain and anchor it.
  - b. Use a steel bar 3 or 4 feet long and about 1 1/2 inches in diameter to secure the sawdust conveyor. Sharpen one end of the steel bar and drive it into the ground at a slight angle so the top leans away from the sawdust conveyor assembly and toward the center of the sawmill.
5. Reeve the feed rope.
  - a. Secure one end of the rope by passing the end through the loop at the bottom of the feed lever.
  - b. Pass the free end of the feed rope toward the log end of the frame, then pass the rope under the carriage above the cross shafts.
6. Reeve the reverse rope.
  - a. Proceed as with the feed rope, except reeve it in the opposite direction with only two coils around the drum.
  - b. Leave enough slack for at least 1 foot of movement (not over 2 1/2 feet) when reasonable pressure is applied.

**NOTE:** The feed rope is usually 64 feet long and the reverse rope is 56 feet long.



**Performance Steps**

- c. Thread the rope into the sawmill and check the tension.
- 7. Test the carriage.
  - a. Make several short travels of the carriage.
  - b. Increase the length of travel until several full-length travels are made before attempting to take on the first log.
- 8. Maintain the sawmill.
  - a. Lubricate all working parts on the equipment according to the lubrication order.
  - b. Check the saw during operation for overheating due to dullness, misalignment, pitch deposits, and chips collecting on the headsaw apron.
  - c. Check the natural lead and arbor alignment of the saw with the carriage before starting the saw.
  - d. Check the saw guides for the correct setting.
  - e. Ensure that the saw mandrel is running evenly and that the bearings are not overheating.
  - f. Ensure that the entire unit is level (crosswise and lengthwise).
  - g. Ensure that the sawdust auger and chain are free of sticky material.
  - h. Ensure that the feed and reverse ropes are dry and not damaged before operating the sawmill.
- 9. Start the sawmill.
  - a. Ensure that all personnel are clear of the drive belt and the headsaw before starting the headsaw.
  - b. Ensure that the feed set and trip-release levers are in neutral position.
  - c. Test the carriage by moving it along the full length of the trackway several times before placing a log on it. Ensure that the saw is running true.
- 10. Stop the sawmill.
  - a. Set all the levers in the neutral position.
  - b. Stop the engine or set the engine clutch in the neutral position.
  - c. Loosen the drive belt, the feed rope, and the reverse rope, if the unit is to be shut down for an extended period.
  - d. Protect all mechanical parts of the sawmill from the weather. Ensure that the ropes and belts are not exposed to rain or snow.

**Evaluation Preparation:** Setup: Provide the soldier with the items listed in the conditions. Brief soldier: Tell the soldier to set up and operate a trailer-mounted sawmill within one hour. Dig a hole about 6 inches deep in front of each wheel (on level ground) so that when the sawmill is leveled, 50 percent of its weight is removed from the tires. Place a plank of timber underneath each leg. Make several short travels of the carriage and increase to full-length travels before attempting to take on the first log.

<b>Performance Measures</b>	<b>Results</b>	
1. Set up the sawmill.	P	F
2. Leveled the sawmill.	P	F
3. Braced the sawmill.	P	F
4. Set up the sawdust conveyor.	P	F
5. Reeved the feed rope.	P	F
6. Reeved the reverse rope.	P	F
7. Tested the carriage.	P	F
8. Maintained the sawmill.	P	F

**Performance Measures**

**Results**

9. Started the sawmill.

P F

10. Stopped the sawmill.

P F

**Evaluation Guidance:** Score the soldier GO if all steps are passed (P). Score the soldier NO-GO if any step is failed (F). If the soldier fails any step, show him how to do it correctly.

**References**

**Required**

FM 5-488

**Related**

**APPENDIX A - TRAINING AMMUNITION**

A-1. This appendix lists the mines and explosives, live and inert, required to support the training of critical tasks for skill levels 1 and 2 of military occupational specialty (MOS) 51B.

A-2. Training ammunition. The two types of training ammunition are live and inert.

a. Types of live ammunition include--

- (1) Demolition charge block 1/4 pound trinitrotoluene (TNT) block demolition charge
- (2) M11 branch line
- (3) M12 transmission
- (4) M9 holders used for blasting
- (5) M60 fuse igniter
- (6) M142 multipurpose firing device
- (7) M11 nonelectric blasting cap
- (8) Detonating cord
- (9) M14 blasting caps
- (10) M1 activator
- (11) Composition C4 (C4) explosives
- (12) Dynamite explosives

b. Types of inert ammunition include--

- (1) M81 igniter, time-blasting fuze
- (2) M1A4 priming adapter
- (3) M14 time-delay fuse
- (4) M15 antitank (AT) mine
- (5) M19 AT mine
- (6) M21 AT



**APPENDIX B - DEPARTMENT OF THE ARMY (DA) FORM 5164-R (HANDS-ON EVALUATION)**

B-1. This appendix provides a copy of DA Form 5164-R. Locally reproduce DA Form 5164-R on 8 1/2-by 11-inch paper.

B-2. The use of this form is optional, but highly encouraged. This evaluation allows you to maintain and track the soldier's proficiency at the performance level.

B-3. Use the following instructions to complete DA Form 5164-R. Enter the title and number of the task to be evaluated at the top of the form.

- In column "a" enter the number of each performance step from the evaluation guide.
- In column "b" enter each performance step from the evaluation guide that corresponds to the number in column "a." Abbreviate information, if necessary.
- If more than one soldier will be evaluated on the specific task or the same soldier will be evaluated more than once, you may locally reproduce the partially completed DA Form 1564-R.
- Before evaluating a soldier, enter the date, the evaluator's name, and the soldier's name and unit.
- For each performance step evaluated, enter a check in column "c" (PASS) or column "d" (FAIL), as appropriate.
- Check the status block GO or NO-GO.

<b>HANDS-ON EVALUATION</b>		DATE	
For use of this form, see AR 250 5-3; the proposed agency is ODCOOPS			
TASK TITLE		TASK NUMBER	
ITEM a	PERFORMANCE STEP TITLE b	SCORE (Check One)	
		PASS c	FAIL d
		<input type="checkbox"/> P	<input type="checkbox"/> F
		<input type="checkbox"/> P	<input type="checkbox"/> F
		<input type="checkbox"/> P	<input type="checkbox"/> F
		<input type="checkbox"/> P	<input type="checkbox"/> F
		<input type="checkbox"/> P	<input type="checkbox"/> F
		<input type="checkbox"/> P	<input type="checkbox"/> F
		<input type="checkbox"/> P	<input type="checkbox"/> F
		<input type="checkbox"/> P	<input type="checkbox"/> F
		<input type="checkbox"/> P	<input type="checkbox"/> F
		<input type="checkbox"/> P	<input type="checkbox"/> F
		<input type="checkbox"/> P	<input type="checkbox"/> F
		<input type="checkbox"/> P	<input type="checkbox"/> F
		<input type="checkbox"/> P	<input type="checkbox"/> F
		<input type="checkbox"/> P	<input type="checkbox"/> F
		<input type="checkbox"/> P	<input type="checkbox"/> F
		<input type="checkbox"/> P	<input type="checkbox"/> F
		<input type="checkbox"/> P	<input type="checkbox"/> F
		<input type="checkbox"/> P	<input type="checkbox"/> F
		<input type="checkbox"/> P	<input type="checkbox"/> F
EVALUATOR'S NAME		UNIT	
SOLDIER'S NAME		STATUS <input type="checkbox"/> GO <input type="checkbox"/> NO GO	

DA FORM 5164-R, SEP 85

EDITION OF DEC 82 IS OBSOLETE

USAPPO V3.02

**APPENDIX C - DEPARTMENT OF THE ARMY (DA) FORM 5165-R (FIELD EXPEDIENT SQUAD BOOK)**

C-1. This appendix provides a copy of an overprinted DA Form 5165-R for the tasks in this Soldiers Training Publication (STP).

C-2. Trainers should use the following instructions when completing DA Form 5165-R.

- Required DA Forms 5165-R (preprinted) are provided in this appendix. Blank reproducible forms may be obtained in Army Regulation (AR) 350-41. All forms may be reproduced locally on 8 1/2- by 11-inch paper.
- Make all entries in pencil.
- Enter the task number and a short title in the appropriate column or use the preprinted form provided.
- Record the date in the GO block if the soldier demonstrates task proficiency to the soldier's manual standards. Keep this form current by always recording the most recent date on which the soldier demonstrated task proficiency.
- Record the date in the NO-GO block if the soldier failed to demonstrate task proficiency to the soldier's manual standards. Soldiers who fail to perform the task should be retrained and evaluated until they can do the task. Once the soldier performs the task correctly, enter the date in the GO block and erase the previous entry from the NO-GO block.
- Read down each column (GO/NO-GO) to determine the training status of that individual. This will give the trainer a quick indication of tasks on which a soldier needs training or be evaluated.
- Read across the rows for each task to determine the training status of all the soldiers. The trainer can readily see on which tasks training should be focused.
- Add the names of newly assigned soldiers to one of the blank columns.
- Line through the training status column of any soldier who departs from the unit.

**NOTE TO THE TRAINING MANAGER:** The training status of groups can be maintained (such as team, squad, or platoon) in key critical military occupational speciality (MOS) at any level by entering the level (such as 1st platoon, 2nd platoon, or 3rd platoon) in the column headings. Simply have the trainers report the percentage of their soldiers who have (GO blocks) and have not (NO-GO blocks) demonstrated proficiency on each task and record this information for each level.





**APPENDIX D - CONVERSION FACTORS (UNITED STATES (US) UNITS AND METRIC)****Table D-1. Metric conversion chart**

<b>US Units</b>	<b>Multiplied By</b>	<b>Equals Metric Units</b>
<b>Length</b>		
Feet	0.30480	Meters
Inches	2.54000	Centimeters
Inches	0.02540	Meters
Inches	25.40010	Millimeters
<b>Area</b>		
Square inches	6.45160	Square centimeters
Square feet	0.09290	Square meters
<b>Volume</b>		
Cubic inches	16.38720	Cubic centimeters
Cubic feet	0.02830	Cubic meters
<b>Metric Units</b>	<b>Multiplied By</b>	<b>Equals US Units</b>
<b>Length</b>		
Centimeters	0.39370	Inches
Meters per second	2.23700	Miles per hour
Millimeters	0.03937	Inches
Meters	3.28080	Feet
Meters	39.37000	Inches
<b>Area</b>		
Square centimeters	0.15500	Square inches
Square meters	10.76400	Square feet
<b>Volume</b>		
Cubic centimeters	0.06100	Cubic inches
Cubic meters	35.31440	Cubic feet



**GLOSSARY****Section I**  
**Abbreviations**

<b>/</b>	divided by
<b>+/-</b>	Plus or minus
<b>0</b>	phase
<b>1SG</b>	first sergeant
<b>30</b>	3-phase
<b>ACCP</b>	Army Correspondence Course Program
<b>AHD</b>	antihandling device
<b>AIT</b>	advanced individual training
<b>AN</b>	annually
<b>ANCOC</b>	Advanced Noncommissioned Officer's Course
<b>AR</b>	Army regulation; Army Reserve
<b>ARTEP</b>	Army Training and Evaluation Program
<b>AT</b>	antitank
<b>attn</b>	attention
<b>B</b>	width of the T beam; width of the stringers; filler block
<b>BA</b>	biannually
<b>BF</b>	board feet
<b>BM</b>	bimonthly
<b>BNCOC</b>	Basic Noncommissioned Officer's Course
<b>BOM</b>	bill of materials
<b>BW</b>	biweekly
<b>C</b>	confidential; cripple studs
<b>C4</b>	composition C4
<b>CL</b>	combat lifesaver; centerline
<b>cm</b>	centimeter

<b>CMF</b>	career management field
<b>CPL</b>	corporal
<b>CSM</b>	command sergeant major
<b>D2S</b>	dressed two sides
<b>D4S</b>	dressed four sides
<b>DA</b>	Department of the Army
<b>DC</b>	Dental Corps; District of Columbia
<b>DCL</b>	door centerline
<b>DWG</b>	drawing number
<b>E</b>	voltage; exposure
<b>E1</b>	private 1
<b>E2</b>	private 2
<b>E3</b>	private first class
<b>E4</b>	specialist
<b>E5</b>	sergeant
<b>E6</b>	staff sergeant
<b>E7</b>	sergeant first class
<b>E8</b>	master sergeant; first sergeant
<b>E9</b>	sergeant major; command sergeant major
<b>EPMS</b>	Enlisted Personnel Management System
<b>F</b>	frequency; fail
<b>FM</b>	field manual; frequency modulated
<b>ft</b>	feet
<b>GED</b>	general education development
<b>GTA</b>	graphic training aid
<b>HL</b>	head lap
<b>intel</b>	intelligence
<b>ITEP</b>	Integrated Test/Evaluation Program

<b>ITP</b>	individual training plan
<b>kw</b>	kilowatt
<b>lb</b>	pound
<b>ldr</b>	leader
<b>LRA</b>	local reproduction authorized
<b>MDI</b>	modernized demolitions initiators
<b>METL</b>	mission-essential task list
<b>MO</b>	Missouri; monthly
<b>MOS</b>	military occupational specialty
<b>MOSC</b>	military occupational specialty code
<b>MPFD</b>	multipurpose firing device
<b>MSG</b>	message; master sergeant
<b>MTP</b>	mission training plan
<b>NAVEDTRA</b>	Naval Education Training Command
<b>NCO</b>	noncommissioned officer
<b>NCOES</b>	Noncommissioned Officer Education System
<b>NCOIC</b>	noncommissioned officer in charge
<b>No.</b>	number
<b>OC</b>	observer/controller; on center
<b>OH</b>	observation helicopter; overhang
<b>OIC</b>	officer in charge
<b>ops</b>	operational procedures; operations
<b>P.</b>	pass; needs practice
<b>pam</b>	pamphlet
<b>PFC</b>	private first class
<b>PLDC</b>	Primary Leadership Development Course
<b>PLT</b>	platoon
<b>PVT</b>	private; point of vertical tangency

<b>QT</b>	quarterly
<b>qty</b>	quantity
<b>RC</b>	Reserve Components; recovery code
<b>recon</b>	reconnaissance
<b>S4S</b>	surfaced four sides
<b>SA</b>	semiannually
<b>SAE</b>	Society of Automotive Engineers
<b>sec</b>	second; section
<b>SFC</b>	sergeant first class
<b>SGM</b>	sergeant major
<b>SGT</b>	sergeant
<b>SL</b>	skill level; side lap
<b>SM</b>	soldier's manual
<b>SMCT</b>	soldier's manual of common tasks
<b>SPC</b>	specialist; standard printing color
<b>sqd</b>	squad
<b>SSG</b>	staff sergeant
<b>STD</b>	standard; sexually transmitted disease
<b>STP</b>	soldier training publication
<b>T &amp; G</b>	tongue and groove
<b>TAMMS</b>	The Army Maintenance Management System
<b>TC</b>	technical coordinator; training circular
<b>TG</b>	trainer's guide
<b>TL</b>	total load; top lap
<b>TM</b>	technical manual
<b>TNT</b>	trinitrotoluene
<b>TO</b>	theater of operations
<b>TRADOC</b>	United States Army Training and Doctrine Command

<b>US</b>	United States
<b>USASMA</b>	United States Army Sergeants Major Academy
<b>V</b>	nerve agent; volt
<b>W</b>	regular flooding; width
<b>WCL</b>	window centerline
<b>wk</b>	weekly
<b>WO</b>	Warrant Officer

## **Section II**

### **Terms**

#### **AN/PSS-12**

hand-held portable mine detecting set

#### **C-4**

A military plastic explosive.

#### **fuse**

A length of readily combustible material that is lighted at one end to carry a flame to and detonate an explosive at the other end.

#### **fuze**

A mechanical, electrical, or electronic mechanism used to detonate an explosive, as a grenade or bomb.

#### **slump cone**

An instrument used to test the consistency of the concrete mixture for workability.

#### **slump test**

A test conducted from representative batches of concrete to test concrete consistency.





## REFERENCES

### Required Publications

Required publications are sources that users must read in order to understand or to comply with this publication.

#### Army Regulations

AR 350-41	Training in Units (This Item is Included on EM 0001).
AR 614-200	Enlisted Assignments and Utilization Management (This Item is Included on EM 0001).

#### Field Manuals

FM 20-32	Mine/Countermining Operations.
FM 25-101	Battle Focused Training.
FM 25-4	How to Conduct Training Exercises.
FM 25-5	Training for Mobilization and War.
FM 5-34	Engineer Field Data.
FM 5-412	Project Management.
FM 5-426	Carpentry.
FM 5-428	Concrete and Masonry.
FM 5-488	Logging and Sawmill Operations.

#### Other Product Types

DA Form 2028	Recommended Changes to Publications and Blank Forms (This Item is Included on EM 0001).
DA Form 2404	Equipment Inspection and Maintenance Worksheet (This Item is Included on EM 0001).
DA Pam 738-750	Functional Users Manual for the Army Maintenance Management System (TAMMS) (This Item is Included on EM 0001).

#### Soldier's Training Publications

STP 5-51H34-SM-TG	Soldier's Manual and Trainer's Guide MOS 51H, Construction Engineering Supervisor Skill Levels 3/4.
-------------------	---

#### Technical Manuals

NAVEDTRA 12521	Training Manual, Builder 3 & 2, Volume 2.
TM 5-704	Construction Print Reading in the Field ATM 85-27.
TM 9-1375-213-12	Operator's and Unit Maintenance Manual Including Repair Parts and Special Tools Lists (This Item is Included on EM-0162).
TM 9-243	Use and Care of Hand Tools and Measuring Tools M6290-AJ-MAN-010; TM 5-10209-10/1; TO 32-1-101; TM-10209-10/1.

### Related Publications

Related publications are sources of additional information. They are not required in order to understand this publication.

#### Field Manuals

FM 20-32	Mine/Countermine Operations.
FM 25-100	Training the Force.
FM 5-102	Countermobility.
FM 5-125	Rigging Techniques, Procedures, and Applications.
FM 5-250	Explosives and Demolitons.
FM 5-34	Engineer Field Data.

#### Graphic Training Aids

GTA 5-10-36	Mine Card, Part 1.
GTA 5-10-37	Mine Card, Part 2.

#### Other Product Types

DA Form 5164-R	Hands-On Evaluation (LRA) (This Item is Included on EM 0001).
DA Form 5165-R	Field Expedient Squad Book (LRA) (This Item is Included on EM 0001).

#### Soldier's Training Publications

STP 21-1-SMCT	Soldier's Manual of Common Tasks Skill Level 1.
STP 21-24-SMCT	Soldier's Manual of Common Tasks (SMCT) Skill Level 2-4.

#### Technical Manuals

TM 43-0001-36	Army Ammunition Data Sheets for Land Mines (FSC 1345) (This Item is Included on EM 0093).
TM 5-6665-298-10	Operator's Manual for AN/PSS-12 Mine Detecting Set TM 5-6665-298-10 (This Item is Included on EM 0093).
TM 9-1375-213-12	Operator's and Unit Maintenance Manual Including Repair Parts and Special Tools Lists (This Item is Included on EM-0162).

**STP 5-51B12-SM-TG**  
**8 JUNE 2000**

By Order of the Secretary of the Army:

Official:



Handwritten signature of Joel B. Hudson in black ink.

JOEL B. HUDSON  
*Administrative Assistant to the  
Secretary of the Army*  
0022203

ERIC K. SHINSEKI  
*General, United States Army  
Chief of Staff*

**DISTRIBUTION:**

*Active Army, Army National Guard, and U.S. Army Reserve:* To be distributed in accordance with the initial distribution number 112385, requirements for STP 5-51B12-SM-TG.