



## Franklin and Electrostatics- Ben Franklin as my Lab Partner

A Workshop on Franklin's Experiments in  
Electrostatics

Developed at the Wright Center for Innovative  
Science Teaching  
Tufts University  
Medford MA 02155

by Robert A. Morse, Ph.D.

©2004  
Sept 2004

Benjamin Franklin observing his lightning alarm.  
Described in Section VII.  
Engraving after the painting by Mason Chamberlin, R. A.  
Reproduced from Bigelow, 1904 Vol. VII

## Copyright and reproduction

Copyright 2004 by Robert A. Morse, Wright Center for Science Education, Tufts University, Medford, MA. Quotes from Franklin and others are in the public domain, as are images labeled public domain. These materials may be reproduced freely for educational and individual use and extracts may be used with acknowledgement and a copy of this notice. These materials may not be reproduced for commercial use or otherwise sold without permission from the copyright holder. The materials are available on the Wright Center website at [www.tufts.edu/as/wright\\_center/](http://www.tufts.edu/as/wright_center/)

## Acknowledgements

Rodney LaBrecque, then at Milton Academy, wrote a set of laboratory activities on Benjamin Franklin's experiments, which was published as an appendix to my 1992 book, *Teaching about Electrostatics*, and I thank him for directing my attention to Franklin's writing and the possibility of using his experiments in teaching.

I would like to thank the Fondation H. Dudley Wright and the Wright Center for Innovative Science Teaching at Tufts University for the fellowship support and facilities that made this work possible. I thank St. Albans School of Washington DC for the sabbatical leave during which the work was done. I thank Eric Chaisson, director of the Wright Center, and my colleagues D. Zach Smith, Nick Deamer, Scott Battaion and Donna Young for various assistance during the development. Nick filmed and edited the videos and Scott created the website. My thanks to Anne Battis, Benjamin Weiss and the staff of the Burndy Library at the Dibner Institute for the History of Science and Technology for their assistance and permission to photograph materials from the Library. My thanks to Ronald Thornton and Janet Marino for the use of laboratory space in the Center for Science and Mathematics Teaching at Tufts. I would especially like to thank Alana Howland for her hospitality and the use of her garret where much of this material was written.

Finally, but most importantly, I thank my wife, Mimi, first for her translations of the French encountered in this work, but mostly for her support, encouragement, help and patience in the entire process.

## Safety and Electrostatic Experiments

All of the devices whose construction is described in this manual are completely safe for use as described, and would have to be scaled up considerably to pose any danger. Build them as described and they will give shocks no greater than you may experience getting out of a car on a winter's day. An accessible description of electrostatic safety in demonstrations and experiments is found in A. D. Moore, *Electrostatics, 2nd ed.*, 1997, LaPlacian Press, Morgan Hill, CA, pp. 114-116.

## **Organization of the work**

This laboratory workshop consists of several sections, each organized primarily around one of Franklin's letters and the experiments described in it. A few of the sections include more theory than experiment. One section discusses the lightning rod experiment and another the kite experiment. Additional sections may be added in the future and will be found on the Wright Center Web site.

This first section provides an introduction and directions for constructing equipment to be used in the experiments. A materials list appears at the end of the section. The written directions are supplemented by a series of movie files that illustrate the techniques.

Additional materials on the website or the CD include an extensive collection of Franklin's works on electricity in PDF format and a collection of images of Franklin, his correspondents and illustrations from books of the period. Many of these are clearly in the public domain and may be used freely. All images have sources credited, and I would ask that users adopt a standard of scholarship by keeping citations with the images.

### ***Movie Titles***

#### **Movies for Section I**

01. Pointy Tab Blunt Tab
02. Drawing the Fire
03. Building the Film Can Leyden Jar
04. Drink Cup Leyden Jar
05. Charging the Film Can Leyden Jar
06. Hanging Foil Bit
07. Lighting the Neon Bulb
08. Building the Generator Part 1
09. Building the Generator Part 2
10. Building the Generator Part 3

#### **Movies for section IV**

11. Conspirators or the Treason
12. Electrostatic Motors

#### **Movie for section IX**

13. Electrostatic Induction

## List of sections

- I. Introduction and construction of equipment**  
Historical introduction and description of equipment and its construction.
- II. Experiments described in letter to Peter Collinson**  
Franklin's first letter describing experiments with points and Leyden jars.
- III. Experiments and theory of the Leyden jar described in letter to Peter Collinson**  
Franklin's second letter begins with his theory of the transfer of electrical fluid in charging the Leyden jar, followed by a series of experiments to support the theory.
- IV. Further experiments on the Leyden jar described in letter to Peter Collinson**  
Experiments which dissect the Leyden jar and show the importance of the dielectric. Construction of a flat plate capacitor, the magical picture and two forms of electrostatic motor.
- V. Franklin's theory of atmospheric electrification and the possibility that lightning is electric.**  
Franklin describes his theory on how clouds might become electrified.
- VI. Opinions and Conjectures concerning the properties and effects of electrical matter...**  
Franklin discusses his theory further, proposes the experiment with the lightning rod to test if lightning is electrical, and suggests the use of lightning rods to protect buildings and ships.
- VII. Franklin on lightning and lightning rods.**  
A collection of several pieces of Franklin's writing on lightning and lightning rods, including a translation of the experiment carried out in 1752 in Marly-la-Ville in France.
- VIII. Franklin's kite experiment**  
Franklin's description of the kite experiment, Priestley's account of the kite experiment, and descriptions of the many experiments later carried out by others using kites to collect atmospheric electricity.
- IX. Electrical experiments made in pursuance of those made by Mr. Canton**  
Franklin's experiments on electrostatic induction based on his idea of the 'electric atmosphere' of charged bodies.

**Materials List – Section I. last page**

## **Sources for Benjamin Franklin's letters and books on electricity**

The text and diagrams for most of the letters were taken from the Federal Edition of *The Works of Benjamin Franklin*, compiled and edited by John Bigelow, published in 1904 by G. P. Putnam's Sons, consulted in the Mugar Library at Boston University and the American University Library. This source will be referenced as Bigelow, with volume and page. This extensive collection of Franklin's work on electricity is available on the Wright Center website <[www.tufts.edu/as/wright\\_center/](http://www.tufts.edu/as/wright_center/)>

Text and diagrams were also taken from *The Works of Benjamin Franklin*. by Jared Sparks, published in 1837 by Hilliard, Gray, and Company, Boston, consulted in the Tisch Library at Tufts University. This source will be referenced as Sparks, with volume and page.

The best reference on Franklin's book, *Observations and Experiments on Electricity, Made at Philadelphia in America* is still the work by I. Bernard Cohen, published in 1941, containing his edited version of Franklin's fifth edition, referenced as Cohen, with page number.

A facsimile on CD of the second English edition is available from Octavo Press,<[www.octavo.com](http://www.octavo.com)>.

A leather bound facsimile of the 1769 edition is available from the Classics of Science Library, Gryphon Editions, <<http://www.gryphoneditions.com/>>.

## **Sources for Franklin portraits, pictures of electrical instruments and diagrams.**

Franklin portraits have primarily been reproduced from frontispieces in the collections by Bigelow and Sparks, and are referenced by volume. The color copy of the Duplessis portrait was reproduced from the *The Franklin Bicentennial Celebration, Philadelphia, 1906*, American Philosophical Society, Philadelphia, PA. Other images will be referenced where they appear.

Pictures of historical electrical instruments were taken by the author, and are used courtesy of the Burndy Library at MIT which has the instruments in their collection.

Illustrations from period texts are referenced as they occur, but a number of illustrations were reproduced courtesy of the Burndy Library at MIT. Thanks to Anne Battis, Ben Weiss, and the staff of the Burndy Library for their assistance.

## **Other references**

*Benjamin Franklin's Science*, I. Bernard Cohen, 1990, Harvard University Press, Cambridge, MA

*Franklin and Newton*, I. Bernard Cohen, 1956, American Philosophical Society, Philadelphia, PA

*Benjamin Franklin, Electrician*, Bern Dibner, 1976, Burndy Library, Norwalk, CT

*Early Electrical Machines*, Bern Dibner, 1957, Burndy Library, Norwalk, CT

*Draw the Lighting Down*, Michael Brian Schiffer, 2003, University of California Press, Berkeley, CA.

## Introduction

We hear a lot about hands-on science, minds-on science and the inquiry method of science teaching and learning. Benjamin Franklin's work on electricity is an interesting example of the investigation of phenomena and the attempt to explain those phenomena by a qualitative conceptual model. Ultimately Franklin's model proved inadequate to fully explain the many phenomena of electricity, but it managed to explain a great deal at the time, and its weaknesses led to better models. Franklin's choice of vocabulary made a permanent impact on the language we use to speak about electricity. Because Franklin, with only a few years of formal education, was not trained in mathematics, his theory of electricity is expressed in terms of verbal imagery and metaphor, and, except for some archaic terms, is easily approachable by teachers and students today. Unfortunately, although much of Franklin's writing on other subjects is readily available, his electrical writings are hard to find. One goal of this project has been to make that work more readily available.

In preparing the workshop, I have transcribed virtually all of Franklin's letters relating to electricity, from sources published in the 19th and early 20th century, in order to make it available free of copyright. The CD that will accompany this material will have Franklin's text as I found it, with the sources cited. I have selected some of the papers that contain experiments, and added my comments and directions for equipment construction. The equipment designs use modern materials and will let you try many of Franklin's experiments. Those who wish to go farther in pursuing Franklin's experiments will find that almost all the tools and techniques they need are introduced in this workshop.

Teachers, this is your chance to experience Franklin's work and decide how you wish to use it in your own classroom. Students, young and old – try the experiments for yourself. Far from being passé, the science of electrostatics is a billion dollar industry today, with applications in modern manufacturing and processing. A knowledge of electrostatics gives an understanding of a fundamental force, which would please the philosophical side of Benjamin Franklin, and can lead to fascinating career opportunities, which would please the practical side of Franklin.

## Joseph Priestley's Introduction to Franklin's work

### “The Experiments and Discoveries of Dr. Franklin”

“Section I.

“Dr. Franklin's discoveries concerning the Leyden phial, and others connected with them.”

“We have hitherto seen what had been done in electricity by the English philosophers, and those on the continent of Europe, till about the year 1750; but our attention is now strongly called to what was doing on the continent of America; where Dr. Franklin and his friends were as assiduous in trying experiments, and as successful in making discoveries, as any of their brethren in Europe. For this purpose, we must look back a few years. As Dr. Franklin's discoveries were made intirely independent of any in Europe, I was unwilling to interrupt the former general account, by introducing them in their proper year. For the same reason, I imagine, it will be generally more agreeable, to see, at one view, what was done in America for some considerable space of time, without interrupting this account with what was doing, in the mean time, in Europe. I shall therefore, digest, in the best manner I can, the three first publications of Dr. Franklin, entitled *New Experiments and Observations in Electricity, made at Philadelphia in America*, communicated in several letters to Peter Collinson, Esq. of London, fellow of the Royal Society; the first of which is dated July 28th 1747, and the last April 18th, 1754.”

“Nothing was ever written upon the subject of electricity which was more generally read and admired in all parts of Europe than these letters. There is hardly any European language into which they have not been translated; and, as if this were not sufficient to make them properly known, a translation of them has lately been made into Latin. It is not easy to say, whether we are most pleased with the simplicity and perspicuity with which these letters are written, the modesty with which the author proposes every hypothesis of his own, or the noble frankness with which he relates his mistakes, when they were corrected by subsequent experiments.”

“Though the English have not been backward in acknowledging the great merit of this philosopher, he has had the singular good fortune to be, perhaps even more celebrated abroad than at home; so that to form a just idea of the great and deserved reputation of Dr. Franklin, we must read the foreign publications on the subject of electricity; in many of which the terms *Franklinism*, *Franklinist*, and the *Franklinian system* occur in almost every page. In consequence of this, Dr. Franklin's principles bid fair to be handed down to posterity, as expressive of the true principles of electricity; just as the Newtonian philosophy is of the true system of nature in general.”

*The History and Present State of Electricity, with original experiments*, by Joseph Priestley, LL.D. F.R.S., pp 191-193  
The Third Edition, Corrected and Enlarged, Vol. I, London, 1775

### **A Franklin Biographical Time Line**

1706 Benjamin Franklin born the 13th child of Josiah and 8th of Abiah Franklin in Boston.

1714 Begins school at Boston Latin School, leaving after one year to attend George Brownell's writing and arithmetic academy, where he failed mathematics.

1716 At age 10, begins work as apprentice in father's soap and candle shop.

1718 At age 12 becomes apprentice in the printing shop of his brother James.

1722 At age 16 writes humorous essays under the name of Silence Dogood.

1723 Becomes (briefly) the publisher of record of the New England Courant.

1723 Runs away to Philadelphia.

1724 Travels to London, works as a printer.

1726 Returns to Philadelphia, begins scientific investigations on shipboard.

1726 - 1745 Establishes himself as a printer in Philadelphia, carries out and begins to report on various scientific investigations and observations, including effects of color on heat absorption, effects of earthquakes, and observations of the Northern Lights. Develops the "Pennsylvania" Stove design, discusses behavior of comets, comments on lunar eclipses and paths of storms.

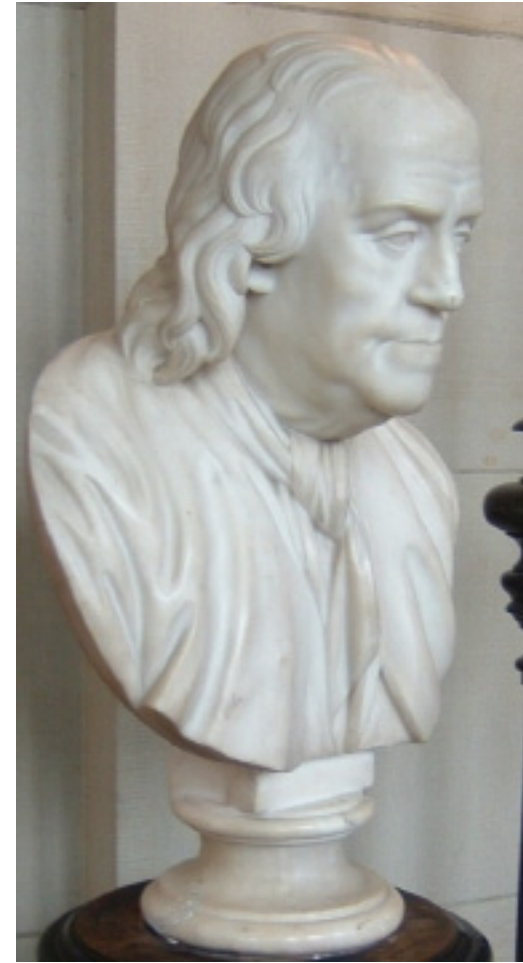

Benjamin Franklin  
Bust by Giuseppe Cerrachi  
in the Boston Public Library  
R. Morse photograph 2004  
(free use with citation)



1744 Attends electrical demonstrations by a Dr. Spencer, beginning his interest in electricity.

1745 Receives gift of “electrical tube” from Peter Collinson, and with friends (Ebenezer Kinnerseley, Philip Syng and Thomas Hopkinson) begins serious, and typically humorous as well, investigation of electricity.

1750 Lightning rod test of electricity proposed. Franklin’s letters read to Royal Society, published in Gentleman’s Magazine.

1751 First edition of *Experiments and Observations on Electricity*.

1752 Test of lightning carried out in France, and by Franklin with kite in Philadelphia.

1754 Receives the Copley Medal of the Royal Society.

1754, 60, 69, 74 subsequent editions of *Experiments and Observations*.

1756 Elected as a Fellow of the Royal Society.

1757 -1762 in London.

1764 - 1775 in London.

1776 - 1785 in Paris.

1790 dies in Philadelphia.

Sources:

*Benjamin Franklin* by Walter Isaacson, 2003 Simon & Schuster.

*Benjamin Franklin’s Scientific Amusements*, Dudley Herschbach, Harvard Magazine, Nov-Dec 1995

*Benjamin Franklin’s Experiments I*. Bernard Cohen, 1941 Harvard University Press.

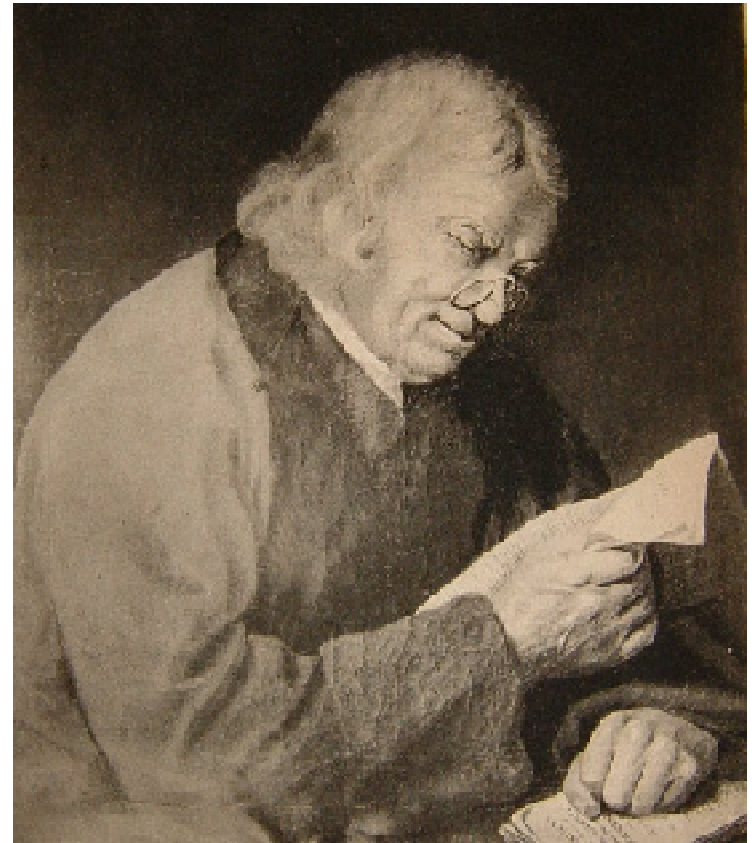

Franklin- from a painting by Stephen Elmer Bigelow 1904 Vol. VI frontispiece (public domain)

## Electrostatics before Franklin

Modern experiments reviewing electrical experiences that would have been known before Franklin begins his work followed by directions to construct equipment to be used in Franklin's experiments. (Materials list on last page)

Tear or cut a tissue into fragments. Take a plastic straw or comb and rub it in your (clean, dry) hair or on your clothes.

Bring it near the paper bits. What happens?

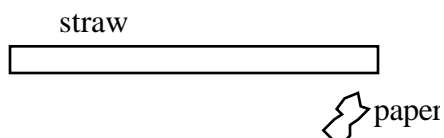

You probably found that the straw attracted the paper bits. The same experiment done in ancient Greece used a piece of amber instead of a plastic straw.

Joseph Priestley (p 2) says

“From **ηληχτρον** [electron], the Greek name for amber, is derived the term **ELECTRICITY**, which is now extended to signify not only the power of attracting light bodies inherent in amber, but other powers connected with it, in whatever bodies they are supposed to reside, or to whatever bodies they may be communicated.”

Joseph Priestley was an English clergyman who met and admired Franklin during Franklin's long stay in England. Franklin encouraged him to carry out his own experiments in electricity and to write his book, *The History and Present State of Electricity*, which is still an interesting description of the history of electricity. Priestley did original research in chemistry as well and was one of the first to isolate oxygen. His unpopular religious views eventually led him to emigrate to America where he settled in Pennsylvania.



Joseph Priestley

by Rembrandt Peale, c. 1801

courtesy Dickinson College

[chronicles.dickinson.edu/encyclo/](http://chronicles.dickinson.edu/encyclo/)

Rub a foam cup on your hair or on cloth.  
Tape a bit of tissue to a thread. Bring the cup near the paper suspended from the thread.  
Watch, play.

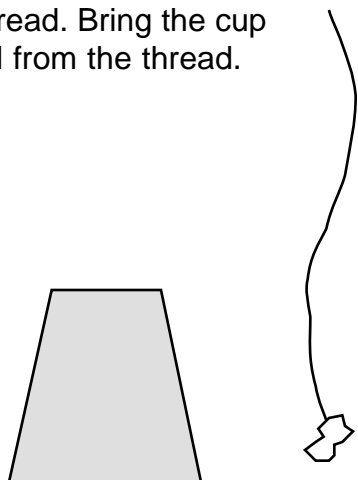

Take a piece of Scotch™Magic™tape about 20 cm (two hands) long, fold about 1 cm of each end back on itself to make blunt tabs on the ends, and tape it to the table.  
Take a piece of tape about 8 cm long (four finger widths) and fold the corners of one end back to make a pointy tab. Stick it down on top of one end of the tape on the table. Make another piece just like it and stick it on the other end of the table tape. Grab the two tapes by their points and pull them off the table tape, then bring the non-sticky sides of the tapes near each other.  
What happens?



*Movie file: 01. Pointy Tab Blunt Tab*

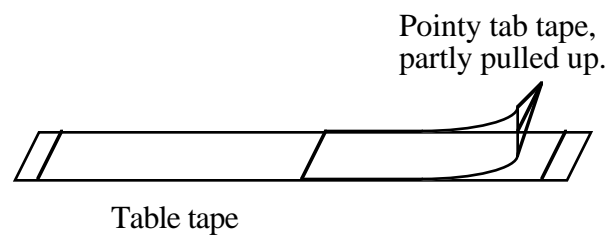

You just saw the two tapes push each other apart, an example of electrical repulsion. Interestingly, although electrical attraction had been known since ancient Greece, repulsion was not recorded until about 1660 by Otto von Guericke of Magdebourg, who also developed an early electrostatic generator. Priestley (p. 10) says

“ His was the discovery, that a body once attracted by an excited electric was repelled by it, and not attracted again till it had been touched by some other body. In this manner he kept a feather a long time suspended above his sulphur globe...”.

Otto von Guericke, more famous for his experiments with vacuum pumps, also made important studies in electricity. His electrostatic generator, made of a sphere of sulphur, was a forerunner of the glass sphere generator of Francis Hauksbee, shown at the right.



Otto von Guericke  
 Courtesy of the Smithsonian Libraries,  
 The Dibner Library  
 for the History of Science and Technology,  
 Washington, DC

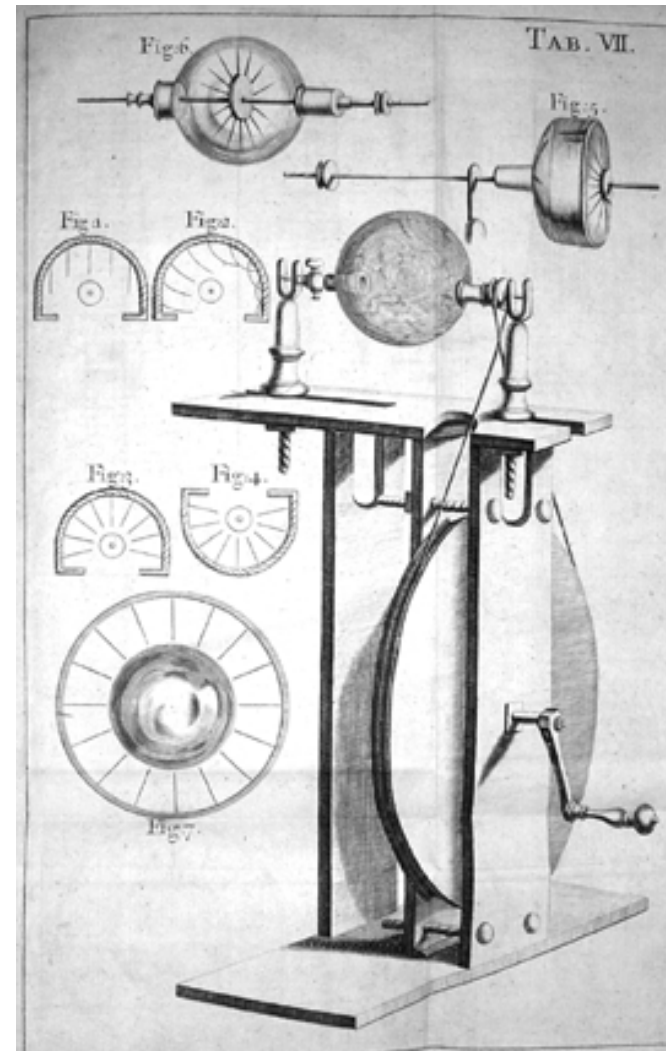

Generator built by Francis Hauksbee. Plate VII,  
*Physico-Mechanical Experiments, 2nd Ed.*, London 1719  
 The Burndy Library, Dibner Institute for the History of Science & Technology  
 Cambridge, Massachusetts

An interesting discovery which created problems for some theories of electricity was that attraction could occur on the surface of an object opposite where it was rubbed. No less a person than Isaac Newton observed this, as described by Priestley (pp. 16-17).

“The great Sir Isaac Newton, though he by no means makes a principal figure in the history of electricity, yet made some electrical observations ... he was the first who observed, that excited glass attracted light bodies on the side opposite to that on which it was rubbed.”



Sir Isaac Newton  
From Helmut, H.F.1902  
[www.lib.utexas.edu/photodraw/portraits/](http://www.lib.utexas.edu/photodraw/portraits/)  
(public domain)

Take a clear plastic cup or a flat piece of acrylic plastic and rub it with hair, dry paper or plastic foam. Take a few paper bits and bring them near the rubbed part on the opposite side of the rubbed surface and watch what happens.

You may also take a bottle or vial of small metal coated glass beads (from a craft store) and rub the outside of the bottle and watch the beads inside. For a class, get small plastic bags and put some beads in each. Students may rub the outside of the bag to see the effect.

(Dave Van Domelen, “A Pocket Electrostatics Demonstration”, *The Physics Teacher*, 41, May 2003, p 306.)

SOURCES: Craft store or search web for “no hole glass beads”  
Art Accentz™ Micro Beedz™, Provo Craft and Novelty, Spanish fork UT 84660  
or  
Nicole™ Treasured Memories™ No Hole Beads, PO Box 846, Mt. Laurel, NJ 08054



**Movie files: 08,09,10. Building the Generator Parts 1,2,3**

The next step in the development of electrical generators was taken by Hauksbee, who made generators with glass globes instead of sulphur globes. (About 1709) The generators we will build are all patterned after those of Hauksbee, as developed by later experimenters. The next really significant steps in the development of better generators were not made until after Franklin's work, and indeed, were made possible by the Franklinian theory of electricity as developed by Franklin and extended by others.

**Electrostatic generator.**

Cut a 16 to 24 inch base from fir 2"x6". (Lumber store)

Cut two sides, 10 " wide by 12 " tall from corrugated plastic such as Strati-Core (art supply or craft store) - corrugations parallel to long side.

Cut a 10 to 12 inch long rotor from a 10 foot length of 3 inch diameter PVC pipe pipe.

A coarse hacksaw or a fine tooth wood saw works well. (Building supply store)

Cut a 6 inch crank piece from 1/2 inch CPVC pipe or dowel. Cut a 3 1/4 inch handle bearing from a 3/4 inch piece of CPVC pipe.

Duct tape the crank piece to the outside of the rotor, overlapping rotor by 2 inches, slip the handle bearing over it, and hold it in place with a 1/2 inch CPVC end cap. (Better- drill holes through handle and rotor and mount with two #8 by 1 inch flat head machine screws with washer and nut.)

Carefully cut holes ( 1 5/8 inch radius) for the rotor in the two sides, using a knife, making the holes just a little larger than the diameter of the rotor, with top of hole 1 inch below top of plastic. Use the template at end of section or mark holes with a compass, then use the wood base as a work surface and cut through the plastic using a sharp knife.(Punch a series of cuts through the corrugations, tangent to the circle, then work around hole, turn over and punch from other side.)

Drill or punch four holes in each side, 1 1/2 inches in from the sides, two at 3/4 inches below the top edge, and two at five inches below the top edge. See template.

Mount the sidewalls on the base centered on each side, using three 1 1/4 inch drywall screws on each side with a #10 washer on each screw head.

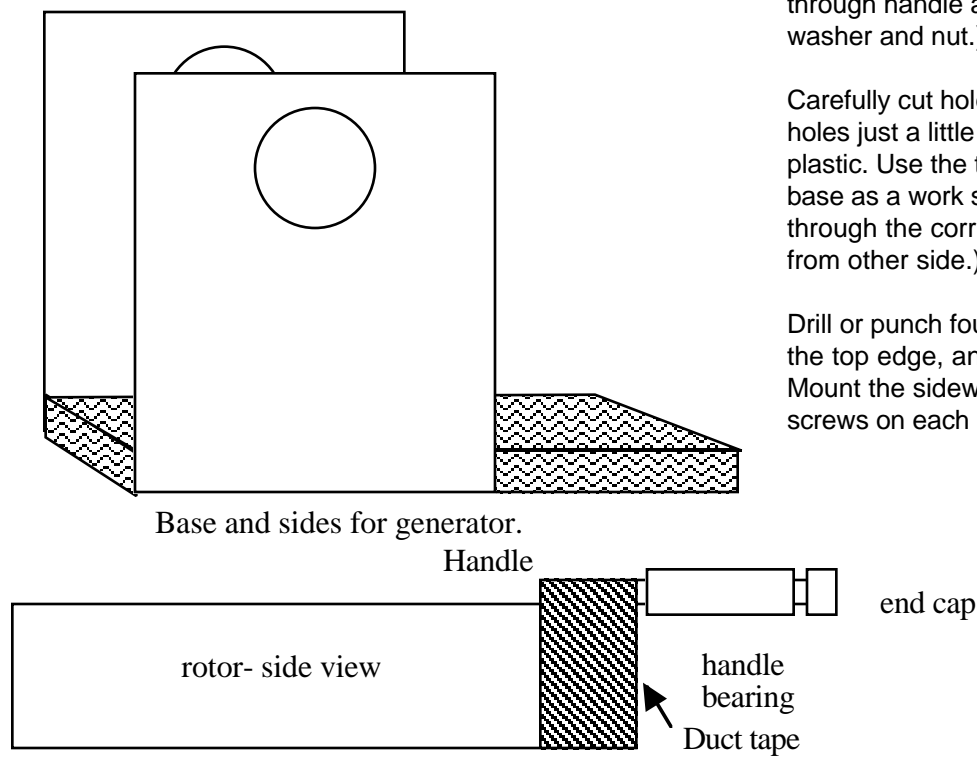

*Early Electrical Machines*, Bern Dibner, 1957, Burndy Library, Norwalk, CT gives a history and discussion of electrostatic generators.

Electrical properties of some old generators are discussed in Bernard S. Finn, "Output of Eighteenth-Century Electrostatic Machines," *Brit. Journ. Hist. Sci.*, vol 5, #19, 1971 pp 289-291.

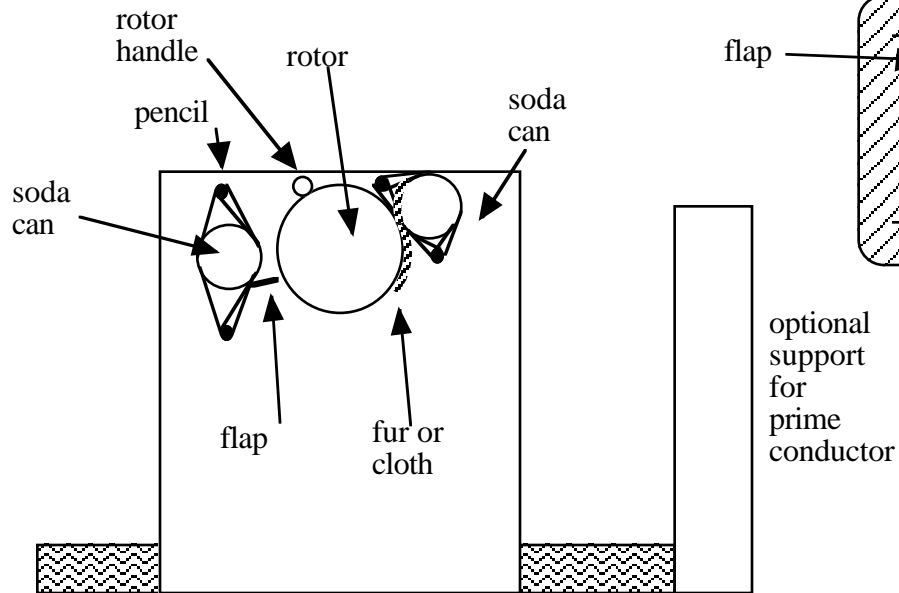

Next mount the “rubber” and the “collector”, which will be made of two empty soda cans supported by pencils and rubber bands.

Cut a one inch wide flap on one side of one can, starting 1/2 inch below the top and ending 1/2 inch above the bottom. Bend the flap out from the can - don't cut yourself.

Take four unsharpened pencils and poke one through each of the four holes on the front face of the generator. Loop four rubber bands around the two pencils on each side of the rotor hole, then push the pencils through the corresponding holes on the other side leaving just the eraser and eraser mount sticking out on the front face.

Take the can with the flap, use the outermost two rubber bands to suspend it in position, while the inner two press against the face near the rotor to keep it from touching the rotor. Adjust it to get an eighth of an inch gap between the edge of the flap and the rotor

Tape a piece of Craft Fur, rabbit fur, wool or other cloth about 3 1/2 inches wide by four inches long to the other soda can, and support it by rubber bands so that the fur presses against the rotor. Use the outer two bands to support the can while the inner two press it against the rotor. Adjust the rubber bands to get a modest pressure, but not so much that the rotor is too hard to turn.

Acrylic CRAFT FUR at craft store or  
[www.kbcrafts.com](http://www.kbcrafts.com)  
 Item 1602 01, size 9" x 12"  
 UPC 28401501 @ \$1.68

Rabbit fur or rabbit pelts- search web  
[www.furandhide.com](http://www.furandhide.com)  
[www.corpsrediscovery.com](http://www.corpsrediscovery.com)  
 etc. About \$4 to \$6 for 10 inch by 12 inch pelt.

To operate the generator, simply turn the crank clockwise. After about ten turns or so, bring your knuckle near the foil surface of one of the collector or the rubber. You should feel a spark.

In this arrangement, the can with the fur will be the positive can. You can test for this a little later with the neon bulb.

Take a square sheet of aluminum foil and fold it into a flat strip about 3 inches wide by 12 inches long. Tape one end to the flap can, and let the other end sit on the base. If you put your hand on this flap as you crank the generator, you will ground that can, and your generator will then act just as Franklin's did.



An Italian generator from about 1740. The pad on the top bar rubs against the glass rotor. The 'prime conductor' or collector is the horizontal metal bar in the front.

R. Morse photograph.  
Courtesy of  
The Burndy Library,  
Dibner Institute for the  
History of Science &  
Technology  
Cambridge, Massachusetts



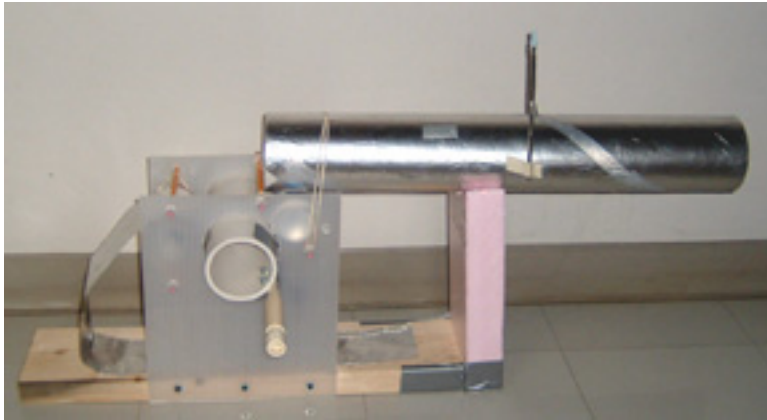

Side view of completed generator with prime conductor. The vertical straw attached to the prime conductor has a hanging foil bit attached to show the state of charge of the prime conductor.

The prime conductor is connected to the positive can, and a long strip of foil is connected to the negative can and brought down to serve as a "ground plane".

You may also connect a second prime conductor to the negative can.

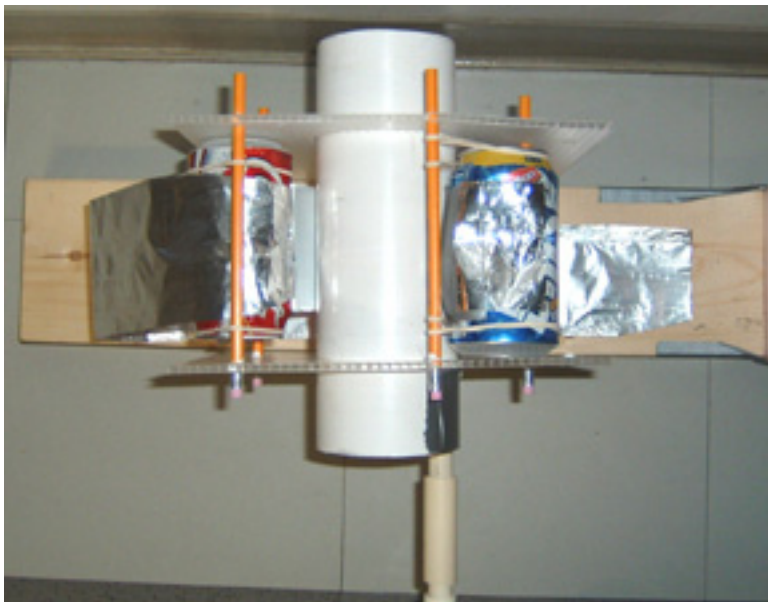

Top View of generator without prime conductor.

collector can (negative) on left

"rubber" can with fur (positive) on right

See page at end of this section for modes of generator use.

### Accessories

**Electrometer:** Cover a straw with foil, and making a hanging foil bit on a piece of tinsel. Use masking tape to attach to the straw, and tape the straw to the prime conductor with a piece of masking tape.

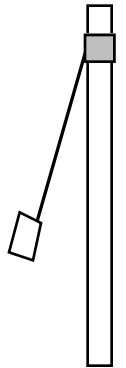

**Chain:** make a chain of paper clips and tape it to the prime conductor- the chain can be used to connect to Leyden jars.

**Hook:** use masking tape to fasten a bent paper clip to the prime conductor as a hook to hang a film can Leyden jar. A paper clip chain fastened to the coating of the jar can be used to connect to the ground plane

Priestley (p 20-21) commenting on Hauksbee and his experiments

“The most curious of his experiments concerning electrical attraction and repulsion are those which shew the direction in which those powers are exerted.”

“Having tied threads round a wire hoop, and brought it near to an excited globe or cylinder, he observed, that the threads kept a constant direction towards the center of the globe, or towards some point in the axis of the cylinder, in every position of the hoop...”

“He tied threads to the axis of the globe and cylinder, and found that they diverged every way in straight lines from the place where they were tied, when the globe was whirled and rubbed.”

See the diagram on the next page.

### **The prime conductor.**

You can increase the capacity of your generator to produce sparks by adding a “prime conductor”, a large tube covered with metal. Take a 3 or 4 inch diameter cardboard mailing tube, and cover it with smooth aluminum foil. Use some glue to hold it in place and tape the seam with Scotch™ Magic™ tape.

Use rubber bands to hold the prime conductor on top of the positive can of your generator, connecting it to the can with a strip of aluminum foil. You may need to support the free end of the prime conductor with an insulating stand such as an empty soda bottle or a piece of foam or plastic.

You may make a second prime conductor for the negative side if you wish.

You may try this experiment with your generator, if you wish. Take a piece of thread about 14 inches long, and tie other threads about two inches long each along the length of the thread so that both ends stick out about an inch. (Make them longer and trim them with scissors if it is easier.) Use a strip of transparent tape across the diameter of each end of the rotor and fasten the ends of the thread there. Watch what happens as you turn the rotor.



Short threads tied on a long one.

The plate on the next page from William Watson’s book shows an experiment with threads outside and inside a glass globe as it is being rubbed.

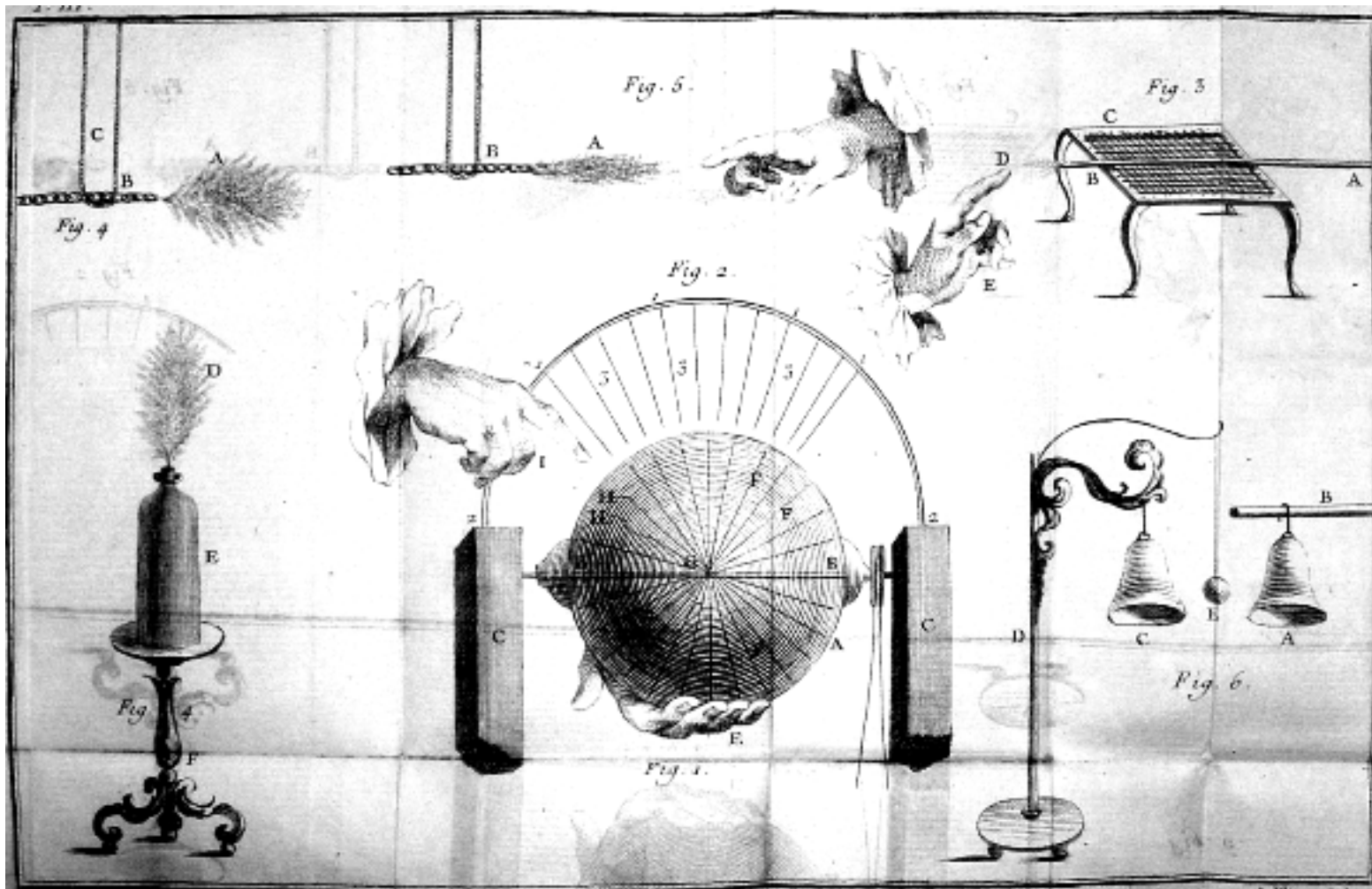

Plate, William Watson, trans. by Jean Freke, *Essai sur la Cause de L'Electricité*, Paris 1748  
 The Burndy Library, Dibner Institute for the History of Science & Technology  
 Cambridge, Massachusetts

## THE LEYDEN PHIAL

Franklin was fortunate in his timing, for just as he got involved with electrical experiments, he was presented with the discovery of the Leyden jar also called the Leyden Phial or simply the “bottle”. Franklin’s attempts to understand and explain the behavior of the Leyden jar, before hearing of European attempts to explain it, stimulated Franklin’s development of his one fluid theory of electricity. The success of his theory made his reputation as a “philosopher”, the term for a scientist at that time.

Priestley recounts the discovery. (pp. 102ff):

“The end of the year 1745, and the beginning of 1746 were famous for the most surprising discovery that has yet been made in the whole business of electricity, which was the wonderful accumulation of its power in glass, called at first the Leyden Phial; because made by Mr. Cuneus, a native of Leyden, as he was repeating some experiments which he had seen with Messrs. Muschenbroeck, and Allemand, professors in the university of that city. But the person who first made this great discovery, was Mr. Von Kleist, dean of the cathedral in Camin.”

The illustration at right shows an electrician holding the bottle in his hand, and about to touch a wire coming from the ‘prime conductor’ of an electric generator.

Quoting Von Kleist’s report, in Priestley

“When a nail, or a piece of thick brass wire, &c. is put into a small apothecary’s phial and electrified, remarkable effects follow: but the phial must be very dry, or warm.” This account is clearly imperfect and unclear. What Von Kleist, and shortly afterward Cuneus and friends actually did was to connect their electric generator to a wire which ran into a bottle of water, while holding the bottle by the outside. When the generator had been turning for a while, the experimenter then grabbed the wire to remove it, while still holding the outside of the bottle, and received a much larger shock than expected. It was soon discovered that simply covering the outside of the bottle with metal foil served as well, and even the water on the inside could be replaced by a metal coating. However, the ease of filling a jar with water let that construction persist.



Woodcut illustrating the Leyden experiment  
from Park Benjamin, *A History of Electricity*, 1898 - reproduced from  
Winckler, 1746.



*Movie file: 03. Building the Film Can Leyden Jar*

**BUILDING LEYDEN JARS.**

**1. FILM CAN LEYDEN JAR.**

(Most photo stores will give you an ample supply of empty film cans if asked, particularly in advance.)



Large paper clip, with straightened end pushed through center of film can cap.

Smooth aluminum foil glued to outside of film can using glue stick or thin glue.

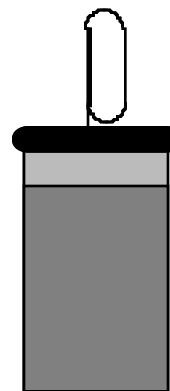

Fill inside of jar not quite to top with water- perhaps with a little salt added. You will need two water-filled Leyden jars later.

OR

carefully glue smooth foil to inside of jar and connect with piece of foil to paper clip.



*Movie file: 04. Drink Cup Leyden Jar*

**2. DRINK CUP LEYDEN JAR**

Take a plastic drink cup (Solo™ 16 oz. or other smooth sided plastic cup—not foam plastic.). Glue a foil coating to the outside of the cup with glue or a glue stick. Glue another foil coating to the inside, making sure the foil is smooth and tight. (Press it in place by putting a second cup inside.)

To connect to the inside foil, coat a plastic drinking straw with foil by gluing a smooth foil coating around the straw, then put the straw inside the cup and put a second plastic cup in to hold it in place.

For some experiments you may want to use a second straw to connect to the outside, holding it on with a rubber band.

A straw with the top inch left uncoated gives an insulating handle which may be useful in picking up the Leyden jar.

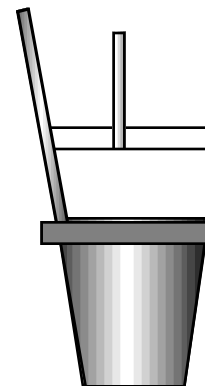

Another variation would be to tape the inner foil covered straw to the inside foil, and to sandwich a second straw between the outside foil and a second outer cup, which has no foil.

*Bigelow vol. III: 217-220*

Excerpt from letter CLXXI

TO THOMAS HUBBARD, AT BOSTON

LONDON, 28 April, 1758.

The bottles have necks, which I think better than to be quite open; for so they would either be exposed to the dust and damp of the air, if they had no stoppers, or the stoppers would be too near together to admit of electrifying a single bottle, or row of bottles; there is only a little more difficulty in lining the inside with tinfoil, but that is chiefly got over by cutting it into narrow strips, and guiding them in with a stick flat at one end, to apply the more conveniently to the pasted side of the glass. I would have coated them myself, if the time had not been too short. I send the tinfoil, which I got made of a proper breadth for the purpose; they should be coated nine inches high, which brings the coating just even with the edge of the case. The tinfoil is ten inches broad, which allows for lapping over the bottom.

I have bored the holes in all the stoppers for the communicating wires, provided all the wires, and fixed one or two to show the manner. Each wire, to go into a bottle, is bent so that the two ends go in and spring against the inside coating or lining. The middle of the wire goes up into the stopper, with an eye, through which the long communicating wires pass, that connect all the bottles in one row.

In the letter excerpted at the left, Franklin is describing how he makes Leyden jars. He was sending a shipment of them in care of Thomas Hubbard for John Winthrop, at Harvard University. Note that Franklin must have made a lot of his own equipment, as he says he would have coated the jars himself, and that he bored the holes in the stoppers. The Leyden jars he is describing had tin foil coatings on both the inside and the outside of the jars, rather than using water.

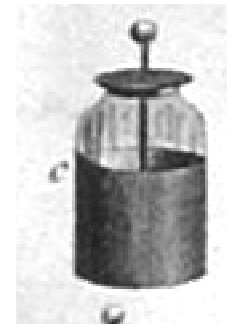

Leyden Jar, Plate III  
G. Adams, *Essay on Electricity*  
5th Ed. London 1799

The Burndy Library, Dibner Institute for  
the History of Science & Technology  
Cambridge, Massachusetts

## FOIL COVERED STRAW BITS

Cut a piece of aluminum foil the length of a plastic straw and wide enough to wrap about 1.5 times around it. Smooth the foil and cover with glue from a glue stick. Wrap it smoothly around the straw, then cut the straw into pieces about half an inch long. Take a spool of thread. Unroll the foil slightly, stick the end of the thread under the foil, paste the foil back down and cut off the thread to a length of about 8 inches. You may also make some of these with Christmas tree tinsel instead of thread.

Alternate construction. Take a pencil and a roll of tape. Use the pencil as a mandrel to make a cylinder of tape with the sticky side out. Stick the end of a thread to the surface of the tape, then stick a strip of foil of the right size to the tape surface. Again you may want to make some with thread and some with tinsel.

Franklin used small pieces of burnt or damp cork. Burning or wetting the cork made the surface a conductor.



Movie file: 06. Hanging Foil Bit

Foil covered straw bit.

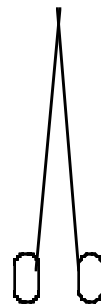

Pair of straw bits on tinsel.

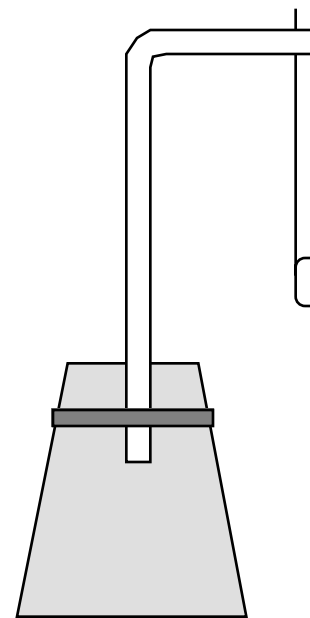

Foil covered straw bit hanging from bent straw fastened to a foam cup with tape or a rubber band.

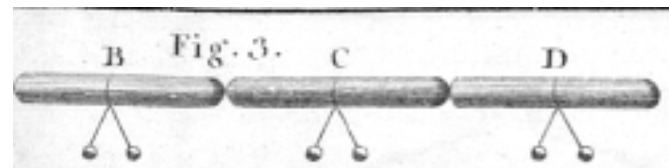

Detail showing three conductors each with a pair of cork balls as charge indicators. Plate I, George Adams & William Jones, *Lectures on Natural and Experimental Philosophy*, 2nd ed. Vol V. London, 1799

The Burndy Library, Dibner Institute for the History of Science & Technology  
Cambridge, Massachusetts

## Note on Numbering of Franklin Letters

For reference, I have usually numbered each paragraph of Franklin's letters, and kept footnotes with the paragraph to which they belong.

Long paragraphs may be broken into parts, each denoted by a letter. For example 2.14e would be my fifth division of the 14th paragraph of Franklin's second letter.

### Franklin's first letter concerning his work in electricity.

*Bigelow, Vol II. p. 170*

1-01

To Peter Collinson Philadelphia, 28 March, 1747

SIR:—Your kind present of an electric tube, with directions for using it, has put several of us on making electrical experiments, in which we have observed some particular phenomena that we look upon to be new. I shall therefore communicate them to you, in my next, though possibly they may not be new to you, as among the numbers daily employed in those experiments on your side of the water, it is probable some one or other has hit upon the same observations. For my own part, I never was before engaged in any study that so totally engrossed my attention and my time, as this has lately done; for what with making experiments when I can be alone, and repeating them to my friends and acquaintance, who, from the novelty of the thing, come continually in crowds to see them, I have, during some months past, had little leisure for any thing else.

I am, &c.,

B. FRANKLIN

The “electric tube” referred to by Franklin was a cylindrical tube of an appropriate kind of glass, perhaps three inches in diameter and several feet long. In use, the tube was to be rubbed by a dry hand or a piece of silk or leather. This would ‘electrify’ the tube and it could then be used to ‘electrify’ other materials or to demonstrate different effects.

Clearly, Franklin was engrossed in electricity, both as a subject of study but also as an entertainment for his friends.

For our tubes we will use a 20 inch (50 cm) length of 1 inch or 1.5 inch diameter PVC pipe, rubbed with wool, acrylic craft fur or rabbit fur. These are inexpensive, convenient and unbreakable, but they charge negatively when rubbed whereas Franklin's glass tubes acquired a positive charge.





Portrait by Duplessis  
Frontispiece, Vol I  
*Celebration of the Two  
Hundredth Anniversary of the  
Birth of Benjamin Franklin,*  
American Philosophical Society  
Philadelphia, 1906  
(public domain)



*Movie file: 02. Drawing the Fire*  
*Movie file: 05. Charging the Film Can Leyden Jar*

Franklin's early experiments would have used the rubbed glass tube to demonstrate electrical attraction and also to charge a Leyden jar.

Rub the tube briskly with the cloth or fur. Bring it near your fingers and see what you feel and hear.

Take a film can Leyden jar and pass the length of the rubbed tube close to the paper clip, while holding the outside of the film can. Do this with several sides of the tube. Repeat rubbing the tube and passing it close to the paper clip about five times.

Test the film can for charge by using a neon bulb discharger or by touching the outside of the can with your first finger and the paper clip with your thumb.

This would have been the experience that people investigating electricity in the mid 1700's would have had, although with larger Leyden jars and bigger shocks.

**SAFETY NOTE:** The shocks from a film can Leyden jar are perfectly safe. Even a Leyden jar made from a pint size (500 ml) plastic jar is safe, although it begins to be uncomfortable for some people. I would not try to make a larger Leyden jar with students. The drink cup version of the Leyden jar will have an "electric capacity" which will be sufficient for the experiments we will do.



The illustration at the left shows the Abbé Nollet using a rubbed tube to charge a young man who is suspended by silk ropes. The seated young woman is about to draw a spark from his nose. Before she draws the spark, the young man can attract bits of paper from the stand below his hand.

As Franklin mentions in his letter, electrical experiments and demonstrations were popular parlor entertainments.

See Schiffer, *Draw the Lightning Down*, chapters 4 and 5 for more information about the sale and use of electrical instruments for education and entertainment.

Frontispiece, Abbé Nollet, 1746

*Essai Sur L'Electricité des Corps*, Paris

The Burndy Library, Dibner Institute for the History of Science & Technology, Cambridge, MA

## SPARKS AND SHOCKS

In Franklin's time, electrical experimenters judged the strength of a spark by its length, its brightness, the noise it made and by how it felt, that is the strength of the shock. We can make the same observations, but in order to work with smaller sparks, we will also introduce the use of a neon bulb, which will allow us to see a flash in small scale experiments, and to determine the direction of the flow of "electrical fluid".

As you use the neon bulb to see flashes from Leyden jars and generators, look carefully at the two electrodes, preferably against a white background. If you look at repeated discharges, you will see that they occur at one electrode or the other, not at both at the same time. This lets you tell the direction of motion of the "electrical fluid"- to use Franklin's term. Franklin's "electrical fluid" will be moving OUT of the electrode that DOES NOT light, and INTO the one that DOES light.

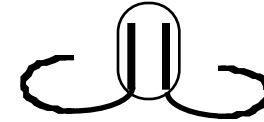

Neon bulb- diagram  
note the two electrodes inside the bulb and the two wire leads sticking out. One lead can be held between thumb and forefinger, while the other is brought near an object to get a spark. Note that the leads are bent in a circle to avoid having a pointed end which might give a slow, invisible discharge. See the experiments in Section II.

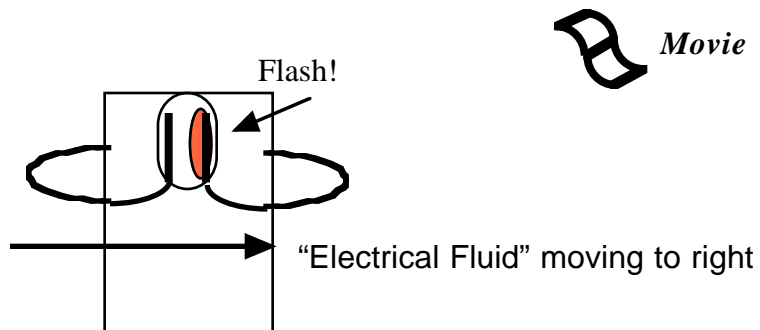

Small piece of white card or paper makes it easier to see the flash.



*Movie file: 07 Lighting the Neon Bulb*

Single neon bulbs can be purchased at Radio Shack for about a dollar. For any quantity, try Mouser electronics <[www.mouser.com](http://www.mouser.com)> part 36NE002, or other electronic supply companies.

### Optional experiment or demonstration

How do we know that the flash occurs at the negative electrode of the neon bulb? You can do an experiment to demonstrate this. We now have electrochemical cells (modern batteries) which have positive and negative poles, and are marked as such. Take eight 9 volt batteries and snap them together in series. Connect a wire to the positive terminal at one end of the group and another to the negative terminal at the other end. Connect one wire to a 10 kilohm resistor which is connected to one wire of the neon bulb. Connect the other wire to the other wire of the neon bulb. The bulb will light, and glow near one electrode. (Don't leave out the resistor-the bulb may arc across the gap). Which battery terminal is the glowing electrode connected with?

(See Layman and Rutledge, "Neon Lamps and Static Electricity", *The Physics Teacher*, 10(1), 49, Jan 1972.)

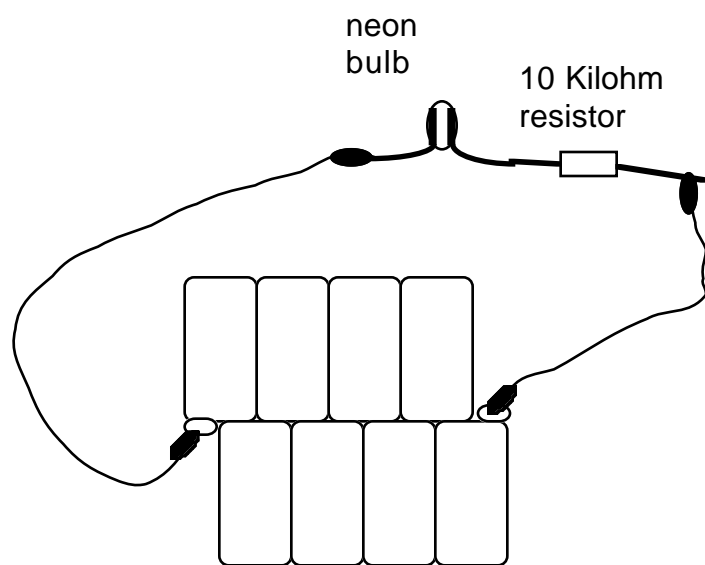

To use this with a class, make up one or more sets and tape them to pieces of stiff cardboard to pass around, or you may mount one on the wall and have students walk by.

Be careful not to touch both the positive and negative wires of this battery or you will get a shock, which could be painful. For student use you might cover the bare wires with clear tape or tubing.

For complete safety, you may put a current limiting resistor in between two groups of four batteries. Buy a battery snap from Radio Shack and connect its leads to the leads of a second 10 kilohm resistor. Use the snap clip to connect the two sets of batteries.

**Materials list for experiments**

straight plastic straws  
bendy plastic straws  
roll of thread  
8 oz. or larger foam plastic cups  
3/4 inch Scotch™Magic™ tape  
16 oz clear plastic cups with smooth sides  
small acrylic plastic pill container  
metallic coated no-hole glass micro beads

20 inch length of 1 or 1 1/4 or 1 1/2 inch PVC pipe

fir 2" x 6" 18 inch long to 24 inch long  
2 pieces 10" by 12" straticore or other corrugated plastic  
(corrugations run the long way)

10" to 12" length of 3 inch PVC pipe  
6" length of 1/2 inch CPVC pipe  
3.5" length of 3/4 inch CPVC pipe  
end cap or coupling for 1/2 inch CPVC pipe

2 #8 by 1 inch or 1 1/4 inch round head machine screws with washers and nuts  
duct tape  
six 1 1/4 inch drywall screws  
six #10 flat steel washers  
heavy duty aluminum foil  
regular aluminum foil  
glue stick  
acrylic Craft fur 12 inch square or so  
(optional- rabbit fur, wool or other cloth pieces)  
aluminized mylar christmas tree tinsel  
4 plastic 35 mm film cans with tops  
giant gem paper clips  
regular paper clips  
water to put in film cans  
rubber bands- 3 1/2 inch by 1/8 inch

**Materials list continued**

4 unsharpened pencils  
1 sharpened pencil

NE-2 neon bulb ([www.mouser.com](http://www.mouser.com) 36NE002)  
10 kilohm, 22 kilohm or 100 kilohm resistor  
8 nine volt batteries

4 empty 12 oz aluminum soft drink cans  
safety pin, medium size

12 inch by 16 inch piece of 2 inch thick foam insulation board

3 inch or 4 inch by 24 inch cardboard mailing tube  
nine inch disposable plastic dinner plate- not foam  
plastic champagne glass - wide type, not flute.  
small brass fasteners

cut out copy of picture of George II.

**Tools list for experiments**

Tools

scissors  
template for generator sides  
cardboard template for leyden jar foils  
hacksaw or fine tooth saw to cut PVC  
utility or exacto knife  
(compass cutter OLFA CMP-1 #23501 1-15 cm)  
phillips screwdriver  
ruler  
1/4 inch drill bit and 5/32 inch drill bit  
hand or power drill

## Various ways to use the generator

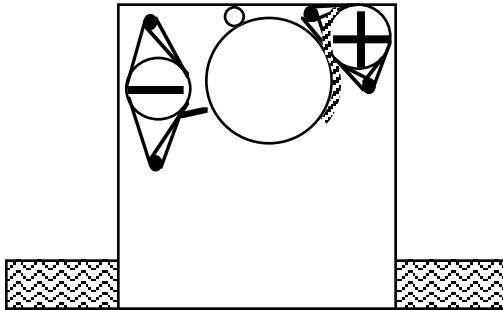

1. Without the prime conductor or the ground plane, the rubbing can becomes positive and the collecting can becomes negative. This is the opposite of the way Franklin's glass globe generator worked. In this mode, only small sparks can be obtained from the cans.

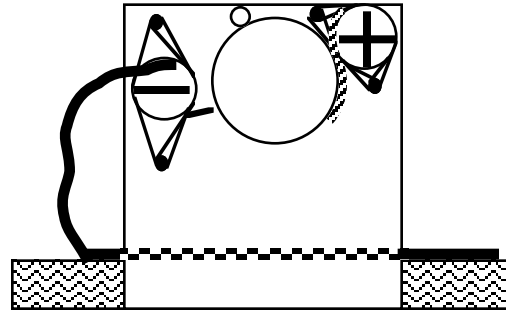

2. Without the prime conductor but with a long foil strip as the ground plane, if you hold your hand on the ground plane as you turn the crank, the rubbing can becomes positive and the collecting can remains neutral. Somewhat larger sparks may be taken from the positive can.

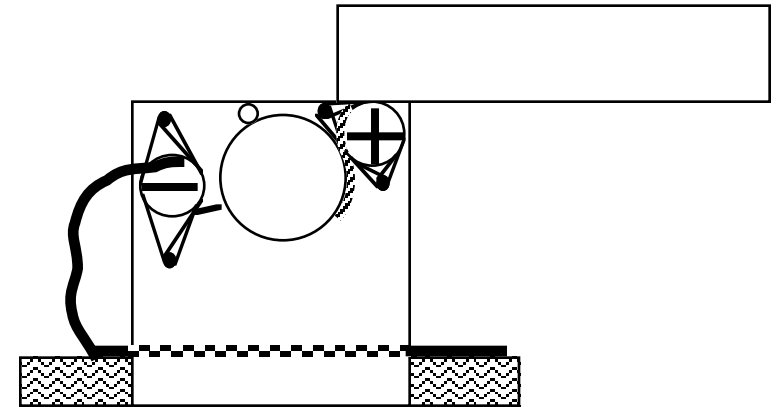

3. With the prime conductor and ground plane, holding your hand on the ground plane as you turn the crank, the rubbing can is positive and the collecting can is neutral. Fairly large sparks may be taken from the prime conductor. This corresponds to the usual set up of Franklin's generator. Mount the prime conductor to the negative can and the ground plane to the positive can and you have a negative charge generator.

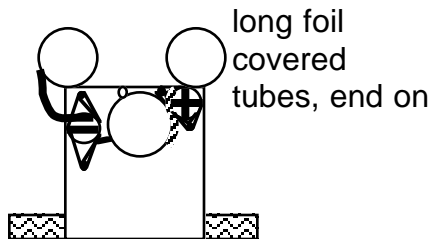

4. Without the ground plane but with two prime conductors mounted parallel to the cans and connected to them by foil strips gives a generator that can give both positive and negative charges relative to a ground plane.

### Charging

The generator is simply used by two people. One person holds the generator with hand on the ground plane or base and turns the rotor. The other person holds a jar by the coating touching the hook to the prime conductor while touching the ground plane with the other hand, or holds the jar by the hook, touching the coating to the prime conductor while touching the ground plane with the other hand.

A single person using the generator can crank for a while and then partially charge a jar, setting it on an upturned foam cup, then crank some more and repeat the process several times.