

Chapter 2

DRAINBACK SYSTEMS

Many contractors have had problems with drainback systems because the system design they installed violated basic drainback principles. They used collectors that would not drain back due to small risers in the collector. Capillary action and surface cohesion will prevent small collector risers from draining. They failed to mount the collectors, reservoir, or pumps as outlined in this chapter. Gravity never fails when we allow it to work. Since this is the only closed-loop system that can be high-limited without a breakdown of the HTF fluid or damage to component parts. The storage tank will last longer than closed-loop glycol systems. It is immune to reverse thermosyphoning. It is the only system where there's no damage to components when the pump fails to run. The water or water/glycol mixture just drains back into the reservoir.

A drainback system uses unpressurized water or water/glycol mixture which is not open to the atmosphere and is separate from the pressurized water that is used in the home. The water or water/glycol mix is added when the pump is off. The same water or water glycol mix is pumped each day to circulate through the solar collectors. When there is heat to be collected, the differential controller turns the pump on. When the pump turns off, all the water drains back down to the same level in the reservoir. This leaves the collectors empty and all the piping empty above the reservoir. A few drainback systems are vented at the reservoir. These are usually large commercial or residential hot water and space heating systems.

The main components that make an unpressurized closed-loop or a drainback system unique are the reservoir tank and the high static head circulation pump used. Drainback systems use a differential controller with temperature sensors. The heat exchangers may be external to the storage tank or incorporated into the storage tank like closed-loop glycol systems, or may be incorporated into the drainback reservoir. A sight glass and/or flow meter are recommended for all drainback systems. The most critical aspect of all drainback systems is gravity. When the pump stops, the liquid (water or a 30% glycol/water mix) must be able to drain out of all the pipes and collectors and return into the reservoir. **Drainback systems have the least maintenance and the absorbers in the collector will last three times longer than in any other system, because the HTF fluid is unpressurized and is never stagnant in the collector.**

An adjustable differential controller is set to start the pump circulation at a point between 8° to 20°F higher temperature from the collector sensor than the tank sensor. Most differential controllers will turn off the pump when the temperature difference between the sensor in the solar collectors and the sensor in the storage tank is around 4° to 5°F. This turn off temperature point is usually not adjustable. Set the differential controller to turn on the circulation pump when there is an 18° to 20°F temperature gain in cold northern climates, with a minimum collector sensor temperature of 80° to 100°F for starting the pump. This 80°F set point is programmed into the Heliotrope Thermal controller. A snap action bimetal switch that closes at 90°F can be wired in series with collector sensors (see page 173). Drainback systems must use a differential controller and a high head AC pump. The AC pump must start up at full speed and full head, unlike variable speed DC pumps that can be used with PV modules in closed-loop glycol systems. Small variable speed DC pumps should only be used in pressurized systems, especially when connected directly to a PV module. The high head AC pump has to not only overcome friction head to circulate the water, but must also be capable of overcoming static head (lifting the water to the highest point of the thermal collectors during initial start up) until the water starts returning - forming a syphon in the circulation loop. The Grundfos UP 26-96BF with 30' of static head or Taco 009 BF with 35' of static head are the two commonly used pumps. These pumps should last 15 years in a drainback system. These combinations used in drainback systems were the highest rated systems in BTU's delivered during the tax credit era according to independent system testing conducted by the Tennessee Valley Authority (TVA). See page iv. The drainback systems typically produce 10 to 15% more BTU's than anti-freeze closed-loop systems with identical collector area.

Basic Drainback Requirements

Drainback systems have certain unique requirements that must be met in order for the system to actually get the water to drain back to the reservoir by gravity when the pump shuts off. There are installation rules for parts and equipment that must be followed to prevent freezing and for high-limiting storage.

- Static head or lift starts at the level of water in the reservoir. It DOES NOT start from where the pump is. The returning water causes both sides, feed and return, to balance each other out. Therefore, if a pump is plumbed next to the tank in the basement and the reservoir is on the second floor in a closet - the static head is the distance from the reservoir level when the water in the feed line reaches the top of the collector. The pump should have enough lift to pump this distance plus a four foot safety factor.
- Do not use vented drainback systems that are open to atmospheric pressure unless your solar collector area is over 500 sq. ft. and you are prepared to add water to the system on an ongoing basis. The entire loop should have no openings, vents, air vents, or vacuum breakers. Most commercial large scale drainback systems are vented to the atmosphere and do not use distilled water.
- **All piping to and from the collectors must have at least a 10° slope and must be using at least 3/4" ID piping - any smaller piping can result in the collectors not draining back properly and freezing.** All slopes in exterior or unconditioned spaces should have at least a 15° slope. All pipe runs should be supported every 4' to prevent sagging which may lead to inadequate draining, especially in unconditioned or exterior spaces. This assists in fluid draining. Collectors must be mounted at a vertical tilt (with the risers running parallel to the roof slope) on a south facing roof and the collector must be placed at a minimum 22° tilt from the horizontal. When using up to three parallel collectors, the lower header should be level or slightly sloped (1/16" per ft.) toward the feed line. More than four collectors need 1 1/2" headers with a 1/16" per ft. slope to the feed line. Never mount collectors horizontal on a south roof. The risers will sag and trap water when mounted horizontally. You would have to use 3/4" risers and have a 1" plumb drop per foot of horizontal length to prevent drainage problems. This is impractical and unsightly. Collectors on an east/west roof can be mounted with the absorber facing south. The collector is mounted inclined on the vertical slope of the roof, mounted exactly as if the roof was flat, with the collectors tilted horizontally with the collectors glass facing south with the long side of the collector inclined down the roof. See page 145.
- The Heliotrope differential controller does not start the pump until the collector sensor is at 80°F is an excellent choice for cold northern climates. If you use a Goldline controller with an 18°F to 20°F ΔT turn-on differential temperature for drainback systems in cold northern climates, you should add a bimetal snap action switch wired in series with the collector sensor. The snap switch is normally open until 90°F and then it closes. This prevents the pump from running until the collector temperature reaches 90°F. This also prevents the controller from starting the pump if either the tank sensor or collector sensor "fails." A high 20°F differential starting point also helps prevent this problem of the pump starting too early, while there might still be ice slush. In extreme northern climates where the entering ground water temperature is under 45°F, move the tank sensor about 1/4 to 1/3 of the way up from the bottom of the tank wall.
- Use 18 gauge 2 wire stranded PVC double jacket exterior wire for runs from the controller to the insulated collector sensor clamped to the top header pipe. **Do not use wire nuts - use 3M 01647 moisture sealant tape and wrap with exterior electrical tape.** The tank sensor should be wedged and insulated against the wall of the tank. It is usually placed against the outside bottom wall of the storage tank.
- Top and bottom collector headers should be at least 1". Use 1 1/2" headers if more than four collectors are used in parallel. Only use 4-way or 2-way grid collectors. Never use serpentine collectors (page 68). **The minimum size for the risers on the absorber plate of a grid collector is 13/32" ID. Never use collectors with 3/8" ID or smaller riser tubing, also do not use roll bond absorber plates.**
- The drainback reservoir can be at any height above the storage tank in conditioned or heated space. It is often placed on the second floor of a two story home to reduce static head. However, **the pump volute must be plumbed vertical, preferably three feet below the bottom water level in the drainback reservoir. Violate these basic principles and you can suck air into the pump causing it to cavitate and burn up. The reservoir should hold about 1 gallon for each 40 sq. ft. of collector area plus three gallons for every 100 ft. of 3/4" pipe or five gallons for every 100 ft. of 1" pipe, plus an extra four gallons to prevent cavitation** (sucking air bubbles into the pump). The minimum size recommended for 80 sq. ft. of collector area is ten gallons. There is no need to calculate the gallons for an external heat exchanger or the fluid in a tank integrated heat exchanger because it will be below the water level of the reservoir and will be filled with water when the pump starts. It is preferable in a two-pump system, that the pump on the collector loop be on the discharge side out of the heat exchanger, to push the water up to the collectors. **Mounting the pump volute vertically on the feed side to the collectors will help eliminate air**

lock problems in all types of solar systems.

- **Add a 33% solution of propylene glycol to the system to prevent freezing** if the controller should ever malfunction and the pumps were to run when the temperature drops below freezing. This is not a common problem, however it can happen.
- All fluid film left in the collector, when the pump turns off, will vaporize to the reservoir before 150°F. You could add a normally closed 44°F freeze sensor in-series with the collector sensor. The sensor opens at 44°F and it will not reset or close until it is 54°F. This will prevent a bad collector sensor or tank sensor from running the pump.
- The water may return faster than it is being pumped to the collector with a return line running over 20' straight down from the collector. A couple of 90° elbows in the return line in a conditioned space or a ball valve above the reservoir may be necessary to slow the water flow. Water falling faster than it's being pumped can cause the piping to vibrate and/or cause the reservoir tank to be extremely noisy. Simply strapping the pipes tighter will not solve the problem. A ball valve above the reservoir will slow the fluid fall to the correct speed.
- Use only low-pressure flow meters that permit back flow when the pump turns off. They are installed across from the upper level of the reservoir, to act as a fill level gauge, when the collectors are empty. The Letro LDF360B .5 -5 gallon/minute flow meter is recommended for 40 to 128 sq. ft. of collector area. Always make sure all external heat exchangers or heat exchange tanks are below the reservoir.
- Special Note: Since drainback systems are unpressurized and are not exposed to corrosive HTF fluids, cheaper copper gas or refrigerant pipe can be used rather than copper plumbing pipe. Gas or refrigerant pipe 7/8" is equivalent to 3/4" ID plumbing pipe. Copper 3/4" ID plumbing fittings fit 7/8" OD gas pipe.

General Pump Requirements for Drainback Systems

Square Footage of Collector Area	Pipe Size		Collector Loop	Double-Pumping ** Waterside AC Pump
	Plumbing	Refrigerant		
0-160 *	3/4"	7/8"	Taco 009 Grundfos UP26-96F	Taco 003 Grundfos UM15-10B5 or 7 March 809 1/100 hp
160-280	1"	1 1/8"	Taco 0011 Grundfos UP26-99F	Taco 006 Grundfos UP15-18SU
280-480	1 1/4"	1 3/8"	Taco 0013 Grundfos UP26-116F	Taco 008 Grundfos UP15-42SF

* Use 1" pipe only when the total pipe run is over 120 feet and collector area is over 128 sq. ft. The Taco 008 or Grundfos UP15-42SF can be used with less than 100 sq. ft. of collector area, if the static head is less than 15 feet. With over 360 sq. ft. of collector area, go to 1 1/2" or 1 1/4" pipe with two 45° elbows or long radius 90° elbow instead of a right angle 90° elbow or a 90° street elbow copper fitting.

The single common requirement for all these systems is that the heat exchanger(s) be sized to achieve the maximum of only 1.4 feet of head loss per 1 GPM and 10.7 feet of head loss at 3 GPM with 63 to 128 sq. ft. of collector area. See specifications for Morningstar on page 66 to get typical collector pressure drop and flow rates. The flow out of a heat exchanger should not be more than 20° F higher than the inlet temperature.

Water-Side Exterior Heat Exchangers: ** Double-pumped systems can use two AC pumps wired to the same controller, as noted above. A water-side option for external tube-and shell thermosyphon heat exchangers is to double-pump them with a DC pump and PV module. Use the 24 volt March with 10 to 12 watts or EI Sid PV 10 DC pumps with a 10 watt PV module with 40 to 96 sq. ft. of collector area. Use the Hartell MD-10-HEH with a 20 to 30 watt module. Use the March 12 volt pump with a 20 watt PV module at 14 volts or the EI Sid PV 20 with a 30 to 40 watt PV module with 100 to 240 sq. ft. of collector area. **DC pumps and PV modules should be used in this situation ONLY with thermosyphon tube-and-shell heat exchangers.**

Break the Rules: The pipe run to the reservoir from the collector outlet must be less than 40'. If the collector area is less than 100 sq. ft. you can use 5/8" ID which is 3/4" OD gas or refrigeration pipe **only from the top of the reservoir vertically on the pipe run to the collector exit.** The 5/8" ID return to the reservoir must always have at least a 30° slope. There must be no lateral pipe runs in the attic or on the roof. The reservoir must be directly below the collectors. All piping from the bottom of the reservoir to the collector inlet must be 3/4" ID pipe. Transition with 3/4" OD to 7/8" OD or 5/8" ID to 3/4" ID adapters.

Reservoir Tanks and Sight Glass/Flow Meters

Alternate Energy Technology has a 10 and 15 gallon copper insulated drainback reservoirs with an optional sight glass. The sight glass is a little clear glass tube on the side of the drainback reservoir, allowing you to periodically monitor the levels of the fluid so that you can see when to add a little distilled water with a funnel as necessary. Care must be taken when installing a sight glass so as not to over tighten it. These reservoirs are available both with and without a heat exchanger in the reservoir. The reservoir with the internal heat exchanger is for double-pumped systems. Another option is to purchase a 10, 12, or 20 gallon conventional water heater and plumb it on the collector's return side above the HE tank to act as the reservoir. *Mobile home parts distributors sell these tanks inexpensively.* Most small water heaters do not have a cold water dip tube at the top. If there is a dip tube, it should be removed. Never use the cold in for the collector return. The temperature and pressure relief port at the top or the hot out should be used for the collector return. The bottom port is the suction to the heat exchanger. A low pressure-drop flow meter can also be used as a sight glass. Place a clear flow meter directly opposite the drainback reservoir. It has to be at the same exact height as the top part of the drainback reservoir on the feed side line to the collector. It must allow back flow. Water will seek its own level after the pump cuts off which should be near the top 1/4" of the flow meter. I prefer flow meters to sight glasses on the side of the reservoir. Flow meters can also be used to check how the pump is performing. Flow meters rated from .5 to 5, 2 to 16, or 2 to 26 gallons/minute, are available from Letro (LD359N or LDF359T) or Blue & White (F-450LHB). Water gauges and liquid level gauges are available from Conbraco. You can create a liquid level gauge as long as it is connected to a parallel return line on the same side as the reservoir.

Filling requires three boiler drains or one fill ball valve and two boiler drains. One is placed above the flow meter opposite the glass on the collector feed side and one above the reservoir (small hot water tank) on the return side. Also put a boiler drain at the lowest point below the pump. Fill, only when the pump is off, with a funnel from one of the upper boiler drains which opens straight up or a ball valve that faces up (see page 25) to allow filling or adding waer. The other upper boiler drain is wide open to let the air out as the distilled water or distilled water/glycol mixture is filled through the funnel. Once water goes above the flow meter or sight glass, stop filling. If necessary, drain water out of the lowest boiler drain until it is at the correct level at the top of the sight glass. Close the two open upper boiler drains. *Note: Many drain back reservoirs require filling with water pressure because low ceilings (below 8') may not allow room above the reservoir for filling. Plug the pump into the differential controller and let it run until the fluid starts coming back into the reservoir. You may want to see Chapter 4 for pressure testing and cleaning with trisodium phosphate on the initial test filling. After five minutes, stop the pump and let all the water drain back. Check the flow meter or sight glass to see that you are draining back to the same level, adding water to properly level as necessary, continuing running the pump. Turn the pump off, checking the drainback level each time. Once finished, unscrew and tie all boiler drain and/or ball valve handles to the pipe.

Advantages from Drainback Systems for Water Heating and Space Heating Hybrids

- System is not damaged if the pump fails to run and the system cannot reverse thermosyphon at night.
- The easiest closed-loop system for do-it-your-sellers to install and maintain.
- The biggest advantage of a drainback system is the high-limit feature of differential controllers. Once the differential controller determines that the tank sensor temperature has reached its high limit, power turns off to the pump and water or water/glycol mixture drains back into the reservoir, preventing the collectors from overheating the storage tank. Storage tanks will last longer than glycol systems that cannot high-limit storage. You can upsize the collectors and storage tanks to function as a small zoned space heating system. The differential controller will automatically turn the system off in the summer when the tank sensor temperature reaches the high limit. If you go on vacation, simply unplug the controller and all the water drains back. The system is immune to utility blackouts. The water drains back to the reservoir when there is no electricity to run the pump or if the controller high limits the storage tank. Larger collector areas per gallon can be sized than pressurized glycol systems.
- Since water or water/glycol mixtures is used as a heat transfer fluid in an unpressurized system, it never needs to be changed like pressurized antifreeze systems. This makes it simple to maintain. Most plumbing codes do not require double wall heat exchangers for drainback systems.
- A homeowner can easily pour distilled or R.O. water or a 30% glycol/water mixture with a funnel into a drainback reservoir, while watching either a sight glass or flow meter, to determine the correct level. Very few homeowners can properly charge pressurized glycol closed-loop systems.
- The system is much simpler with fewer parts, no check valves, no air vents, no pressure gauges, and no

Drainback HE Tank

Freeze protection is provided by gravity in this unpressurized system. Water or water/propylene glycol HTF mix in the collectors and exposed piping drains into the insulated reservoir each time the pump shuts off. This completely protects the collectors since they are empty during the freezing period. When the sun shines on the collectors, the pump is activated and water is pumped from the reservoir to the collectors, allowing heat collection. The collector's bottom header must be sloped toward the inlet. Slightly slope the bottom headers 1/16" per ft. toward the inlet pipe on the feed side of the collectors. The collectors must be mounted vertically with 25° minimum tilt on a flat or south roof, but can be mounted horizontally on a west or east roofs facing south, if they are inclined down the roof, with the glass facing south. See page 141.

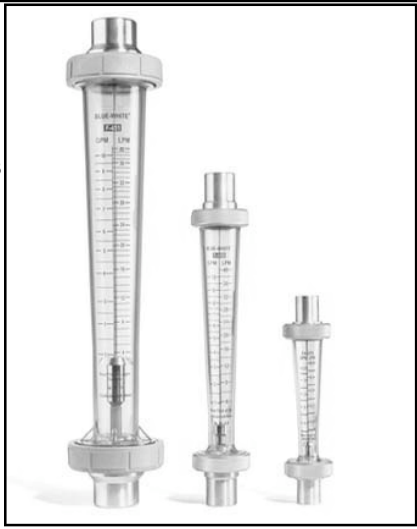
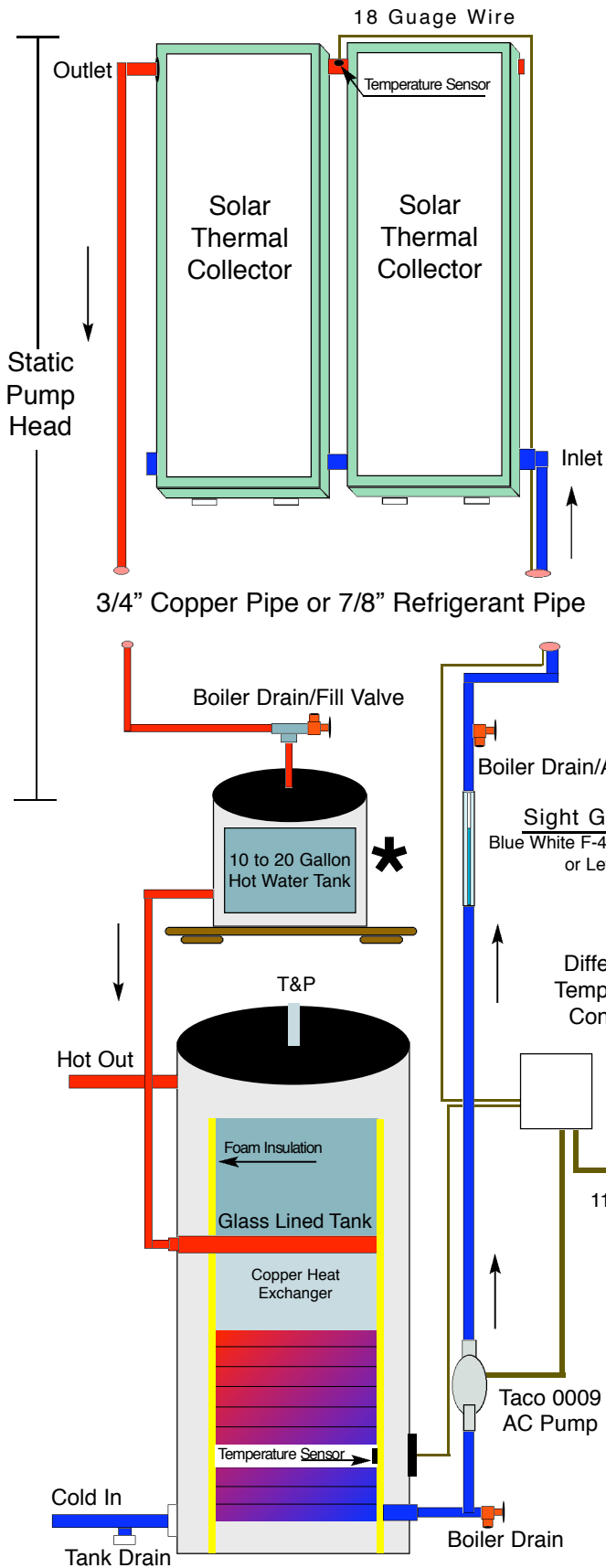

Flow meters in drainback systems can be used as a sight glass. They must have low pressure-drop and be able to drain-back through the flow meter.

★ *Optional Sight Glass*

Reservoir Sizing: Example: One hundred feet of 3/4" pipe requires 3 gallons, plus two 4' x 8' collectors requires 2 gallons. Combining the 2 and 3 gallons equals 5 gallons. Use a 2 safety multiplication factor. 5 gallons times 2 equals 10 gallons. A 10 gallon reservoir is required. Four 4' x 8' collectors would require a 15 gallon reservoir.

Double-Pumped Drainback System with Reservoir Heat Exchanger

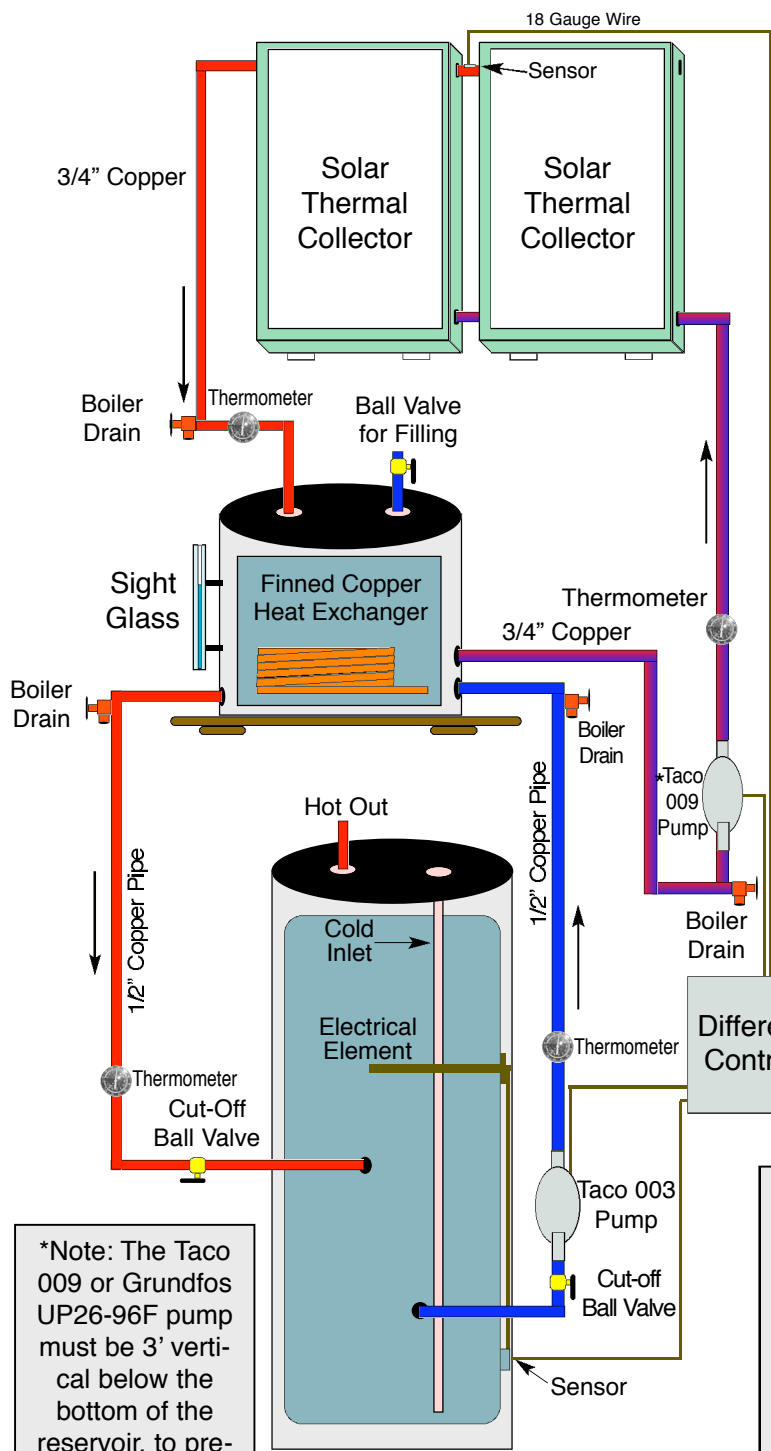

The double-pumped drainback system with a finned copper heat exchanger in a 10 or 15 gallon reservoir is an extremely high-performing system due to the water falling into the reservoir creating turbulent flow around the finned copper heat exchanger shown below. The ball valves on the 1/2" feed and return lines is used to isolate the heat exchanger from the tank for descaling.

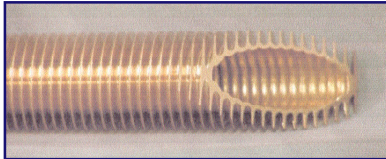

*Note: The Taco 009 or Grundfos UP26-96F pump must be 3' vertical below the bottom of the reservoir, to prevent cavitation.

The reservoir from Advanced Energy Technology with the finned, internal, spiralled heat exchanger may be ordered with or without the sight tube as a sight glass on the feed side to the collector. The reservoir can also be ordered without a heat exchanger for the HE tanks. (See page 25)

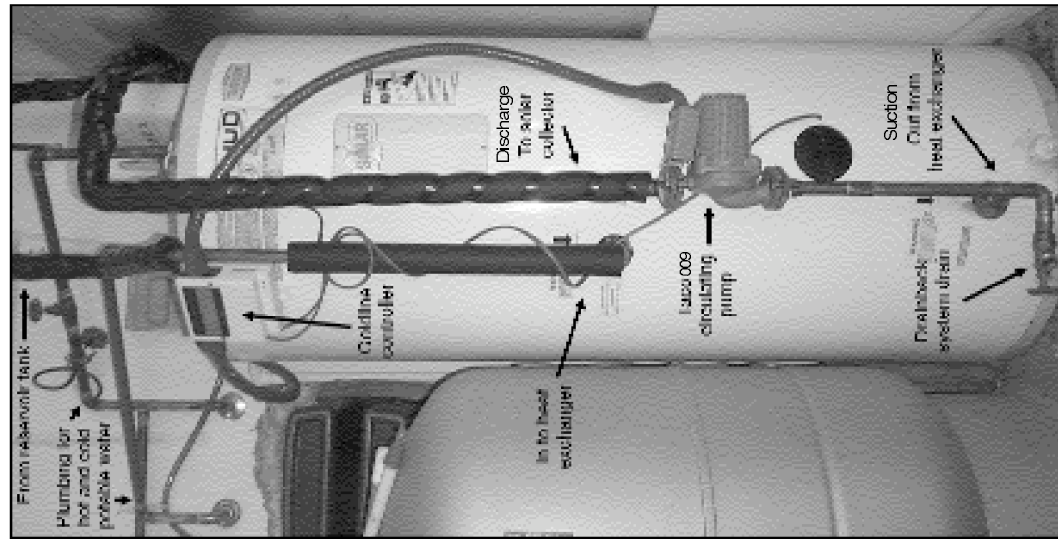

A Ruud 82 gallon solar wrap-around heat exchanger tank with an integral wrap-around heat exchanger that heats through the tank's wall. **Note:** Insulation was intentionally removed below the Taco 009 pump and on the feed line to show the 3/4" copper lines. See diagram on page 23.

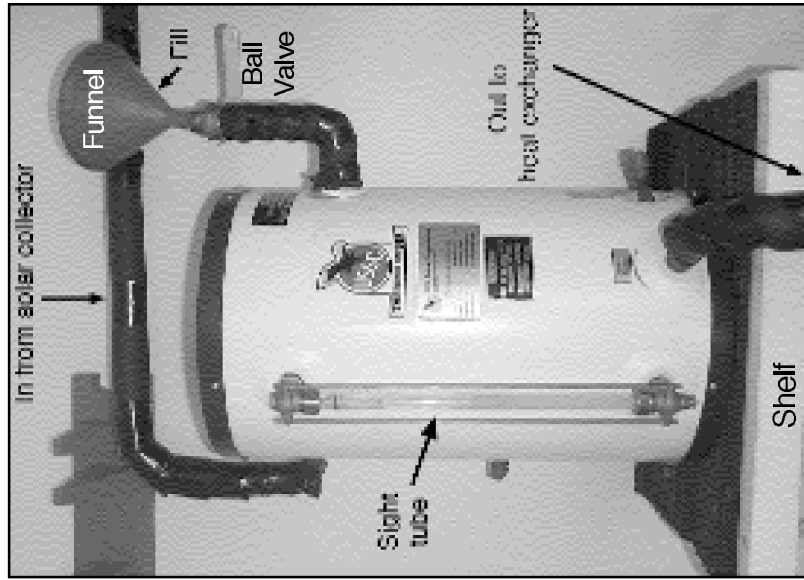

Center Picture above: The heart of a drainback system - the copper insulated reservoir tank stores the unpressurized water from the collectors that "drains back" whenever the pump shuts off. The pump volute must be installed vertical, below the reservoir to prevent cavitation. Copper drainback reservoirs may require a 45 psi pressure relief valve to prevent damage during system pressure testing.

Right Picture: Drainback Double-Pumped Reservoir with an Aluminum Tank Stand by AET. A Pheem side connect open-loop tank is used with the double-pumped drainback reservoir with a finned heat exchanger in the reservoir. A Taco 003 is used to pump the potable water through the drainback copper reservoir. The Taco 009 pumps the drainback fluid. Both pumps are wired to the Goldline controller. The White Painted insulation is for the 1/2" lines to and from the heat exchanger in the reservoir and the Black insulation lines are for the solar loop. Note that both pumps are vertical. See diagram on page 24.

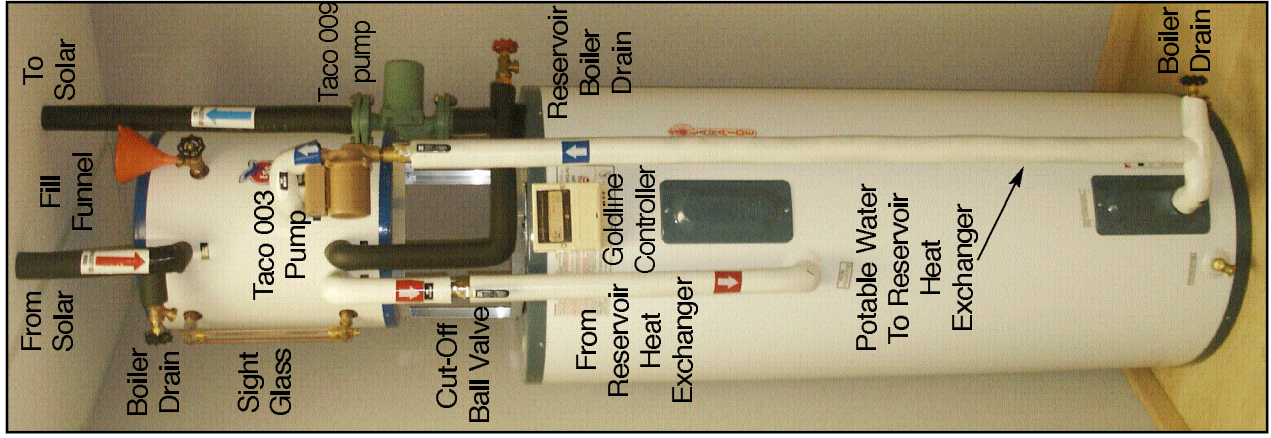

Drainback Solar Collection Loop

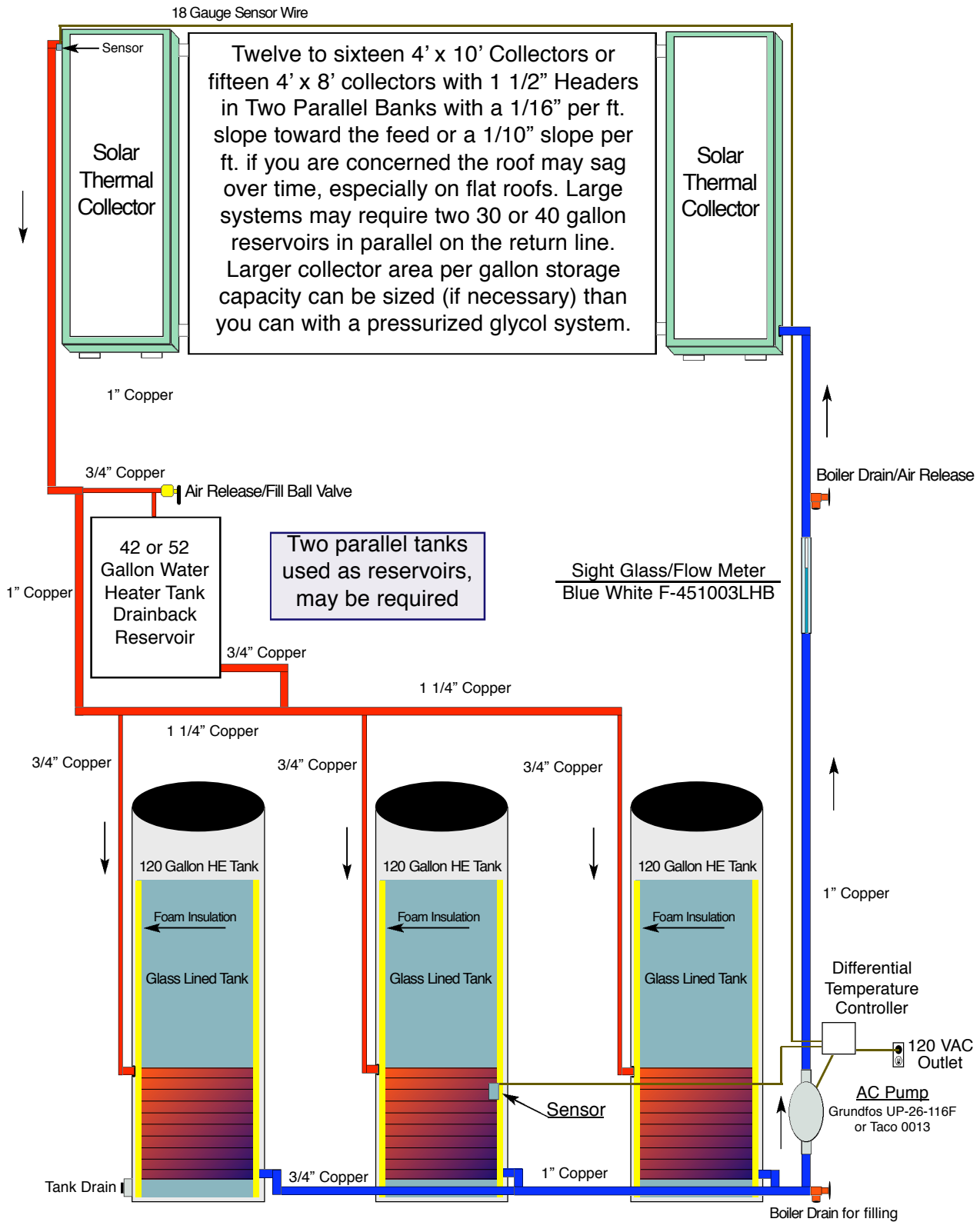

Hot Water, Space Heating, and/or Pool Heating Loop

PV Modules are for Space Heating and Pool Heating Loops Only

Solar Collectors

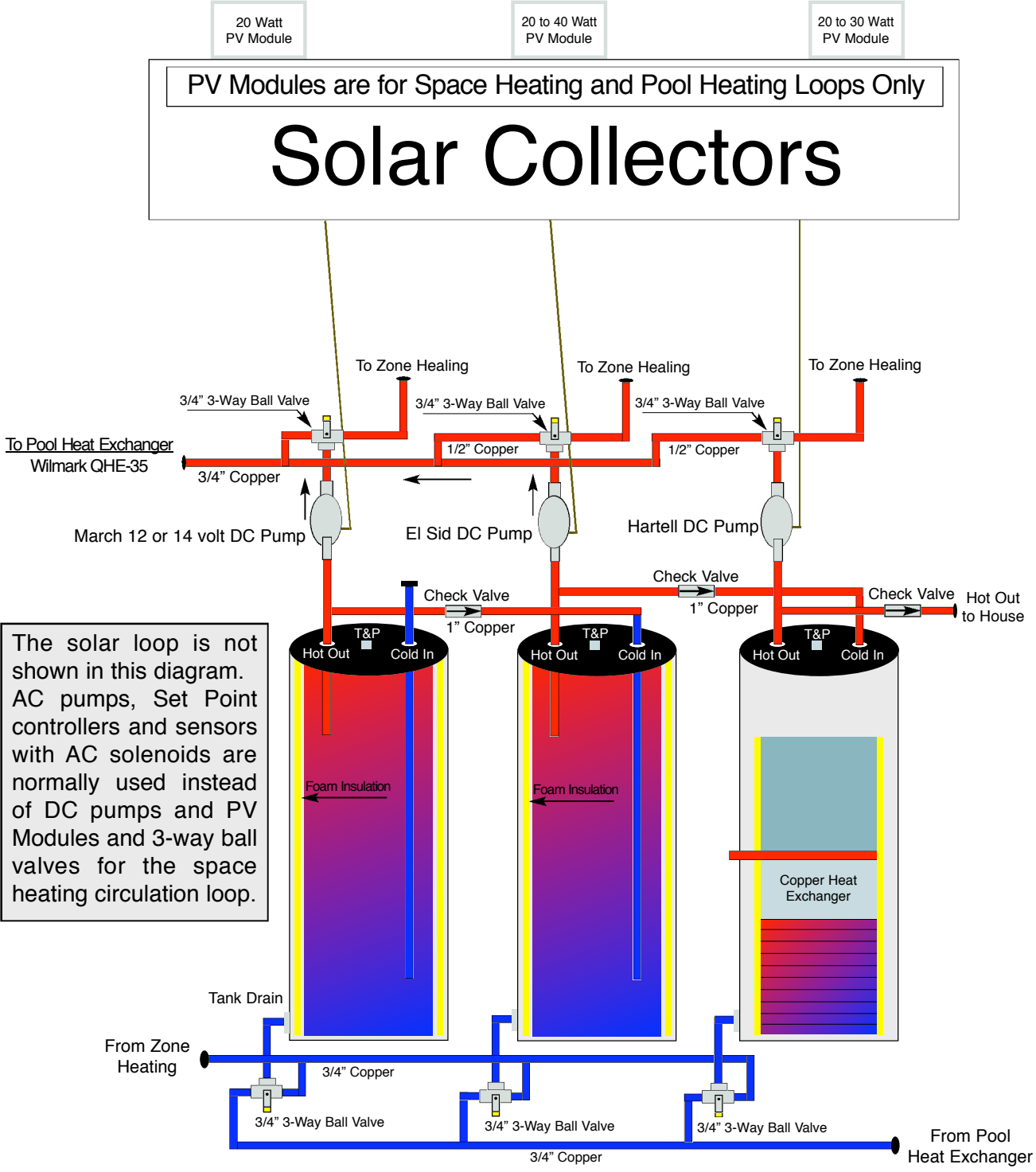

The solar loop is not shown in this diagram. AC pumps, Set Point controllers and sensors with AC solenoids are normally used instead of DC pumps and PV Modules and 3-way ball valves for the space heating circulation loop.

Commercial Drainback System with Large Reservoir

Large high head/high flow pumps, like the Grundfos series L or Sta-rite EC or JH series could be used to create the flow for large scale drainback systems with flat plate collectors. Tropical climates can utilize flat unglazed copper collectors or plastic pool panels with a standard pool pump. All 2 and 3-way ball valves can be replaced with motorized solenoid valves connected to a second Differential Controller with one sensor (A) placed on the exit pipe from the heat exchanger, out of the storage tank, and the other sensor (B) on the recirculating loop or the hot out line of the tank, if there is no recirculating loop. When sensor (A) is warmer than sensor (B), the 2-way solenoid closes and the 3-way solenoid diverts the hot water return to the solar storage tank's feed to the heat exchanger. When using flat plate collectors, the collector return line should be 1' below the water level in the reservoir. This controls a steam flash after the pump starts running when the collectors were stagnating in the sun at start-up.

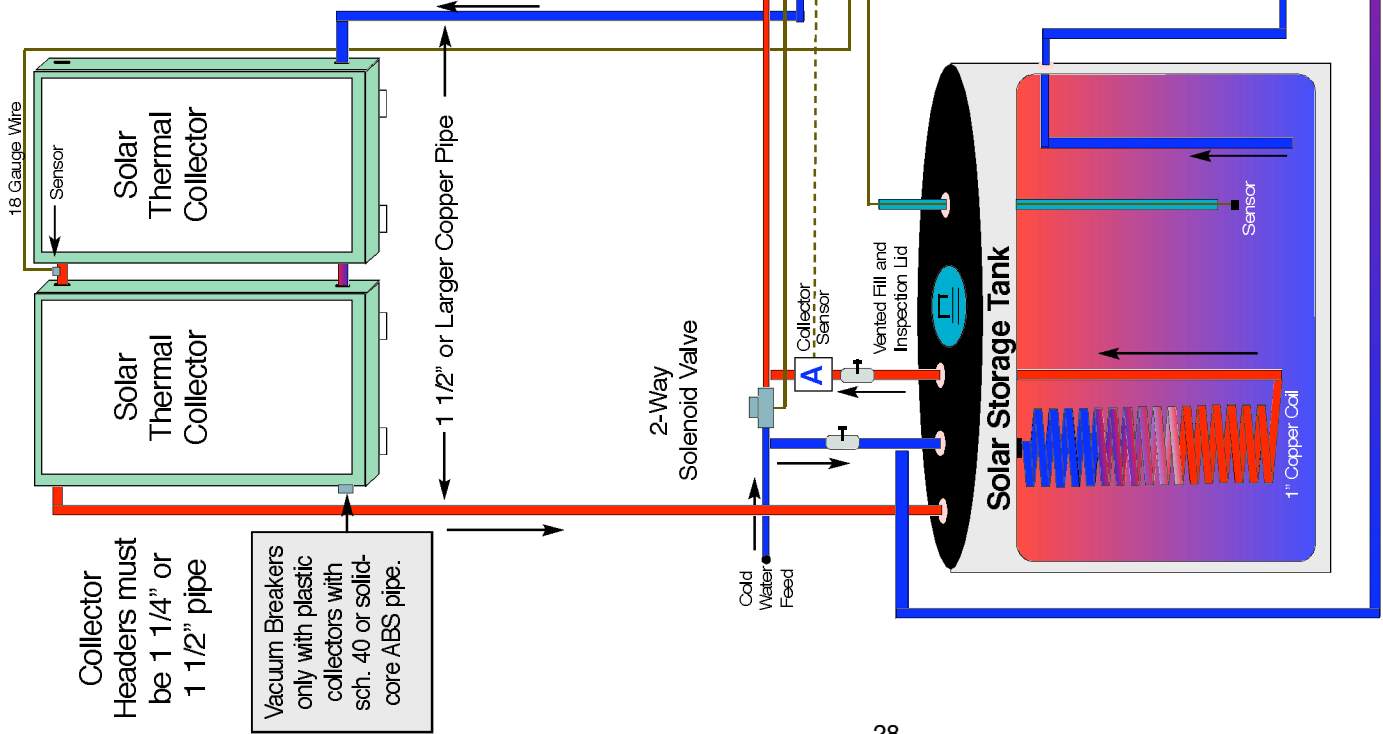

Double-Pumped (Thermosyphon) Drainback Tube-and-Shell System

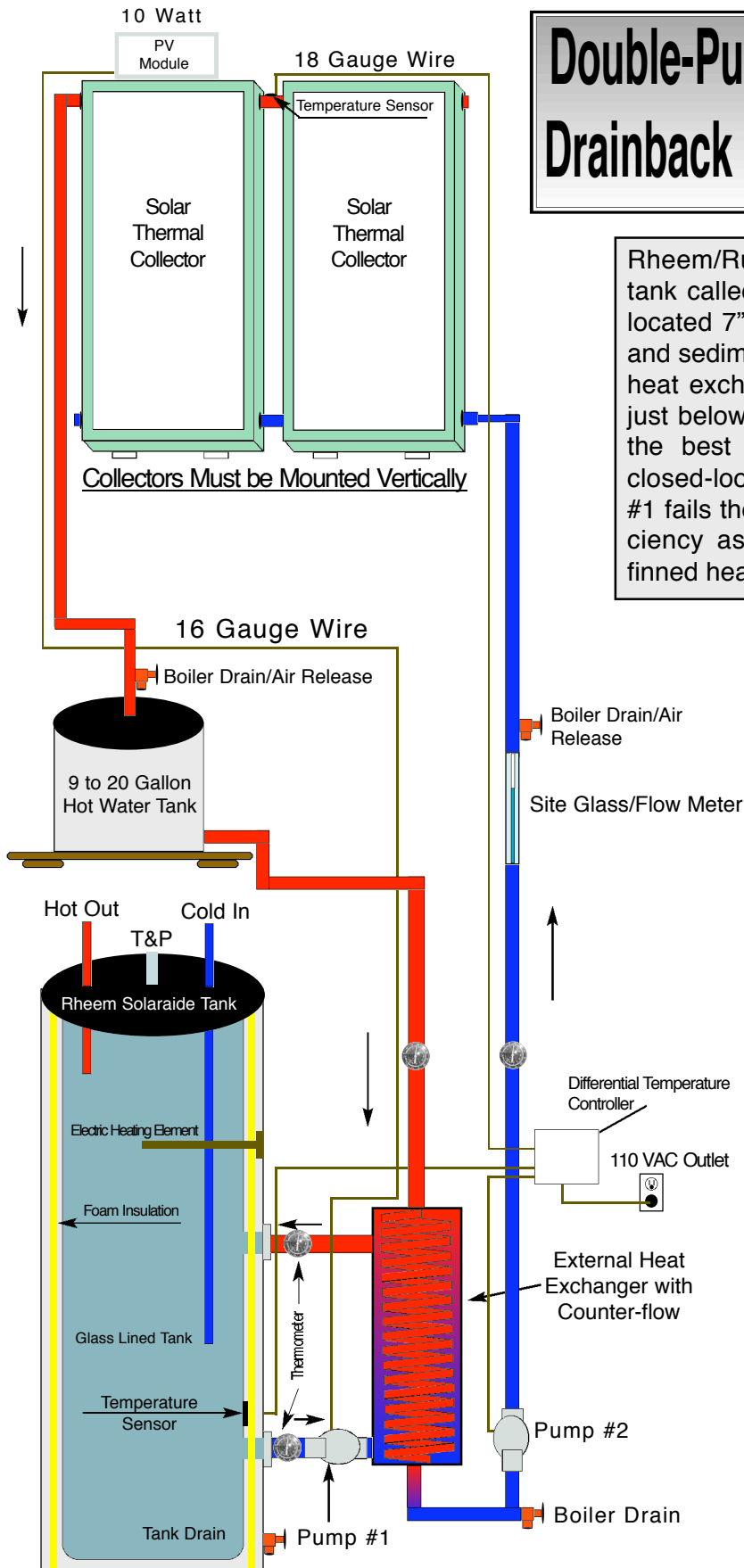

Rheem/Ruud make a side port open-loop tank called the Solaraide. The lower port is located 7" from the bottom to prevent scale and sediment from entering and clogging the heat exchanger. The upper port is located just below the electric element. This tank is the best for a double-pumped drainback closed-loop thermosyphon system. If pump #1 fails the system will still work at 65% efficiency as a thermosyphon system with a finned heat exchanger in a 3" diameter shell.

Pump Options

Pump #1 an El Sid 10 PV or March 24 volt DC pump with an 10 to 12 watt PV module for 40 to 120 sq. ft. of collector area and pump #2 an AC pump with a differential temperature controller. For #1 use the March 12 volt, 20 watt module or El Sid 30 watt module for 128 to 240 sq. ft. of collector area.

Highly Recommended

Pumps #1 and #2 can be AC pumps wired to the same differential temperature controller.

Pump #1 must be 1/100 hp or smaller AC pump like the March 809 oil free model or the Taco 003. (See page 21)

Pump #2 must be a high head AC pump like the Taco 009 or Grundfos UP26-96F.

On the feed and return, cut-off ball valves and boiler drains can be added to the water side of the heat exchanger for descaling and for adjusting the flow, to prevent temperature destratification of the tank.

Double-Pumped Drainback System with Heat Exchangers in the Drainback Reservoir (see page 29)

Alternative Energy Technology is manufacturing a copper insulated drainback reservoir in a 9 and 15 gallon size with a finned copper heat exchanger with internal spirals in the reservoir. This is my favorite system with a water or a water-glycol mix. It is the best closed-loop system ever developed. The reservoir is available with or without a site glass - or without the internal reservoir heat exchanger. A 45 psi pressure relief valve should be installed on the reservoir if your installers are not experienced in installing these systems. This protects the reservoir from excessive air pressure when an air compressor is used to initially check the system for leaks. Do not use small reservoirs without finned heat exchangers. These drainback heat exchangers can be used with an open-loop solar or conventional 80 or 120 gallon tank. I highly recommend this system for 120 gallon tanks with 64 to 128 sq. ft. of collector area or you can also combine two conventional 40 or 50 gallon tanks pumped together as one (see page 130). The water-side pump, wired to the differential controller with the high-head collector loop pump, must be a low-flow, low-head, AC pump, like the March 809 1/100 hp oilless model or the Taco 003, to prevent destratification of the storage tank. See photograph on page 25.

Commercial Drainback Systems

Solar Service Inc. of Niles, Illinois has been installing commercial and residential drainback systems in the Chicago area since 1977. Their website, www.solarserviceinc.com provides photographs such as these of many systems installed in the early 80's, that have proven reliable for about 25 years.



Twentyfour flat-plate 4' x 10' Solar Collectors



- expansion tanks. It is easier to install and maintain than a glycol system.
- Water's specific heat is 10 to 25% better than glycol/water mixtures and water's lower viscosity means that it pumps easier than glycol/water mixtures at lower temperatures.
- Storage tanks last much longer in drainback systems that are used exclusively for space heating. This is because you can turn the system off in the summer when it reaches a preset high limit.
- Collector and system piping does not scale up or corrode. The collector's absorber plate will last three times longer than a glycol system's absorber plate which is often exposed to degrading acidic glycol fluids. Cheaper copper refrigerant pipe can be used rather than copper plumbing pipe. Note: refrigerant pipe is sold by the outside diameter and plumbing pipe is sold by the inside diameter.
- Drainback systems will out-heat antifreeze systems by 15 to 20%.

Drainback Requirements, and Disadvantages

- The system's collector(s) bottom headers must be slightly sloped toward the collector inlet.
- The installer must be careful that the collector's mounting hardware has a slight slope, toward the inlet of the first collector header. Collectors cannot be mounted horizontally on south roofs.
- DC pumps with variable speed motor and low static head are impractical to use with drainback systems.
- The efficient heat exchange properties of water are offset by the fact that only high head AC pumps can be used with drainback systems. The pumps require 140 watts for the Taco 009 BF and 205 watts for the Grundfos UP26-96 BF. These pumps have enough head and flow rate for four (4' x 10')s or five (4' x 8')s with a total pipe run of less than 120 ft. The power requirements result in a 6% reduction of savings from the system from the power required to run the pump AND the differential controller. The running time on a daily basis for a 365 day average is about 4 1/2 hours per day. The Taco 009 is preferable due to the lower power consumption. You may have to put two pumps in series if the static lift to the collectors is over 30 feet above the reservoir water level. The second pump can turn off after start up. **Note:** Substitute the lower power (85 watts) Taco 008 or Grundfos UP15-42 pumps for the Taco 009 or the Grundfos UP26-96 Series pumps IF the top of the collectors is less than fifteen feet above the bottom of the reservoir.
- The drainback system components cost about 10-15% more than a glycol system for a residential solar water heating system. They are usually less expensive than glycol systems when the collector area goes over 96 sq. ft. They typically cost less when space and pool heating combination systems are being combined with DHW systems.
- Drainback systems can be a little noisy - like a coffee percolator. Make sure the water returns through a 90° elbow or two above the water reservoir to cut back the noise of falling water. Adding a water heater insulation jacket to the reservoir can help minimize noise and reduce heat loss from the reservoir. Closet Maid makes a 400 pound capacity shelf. A 20 gallon hot water tank used as a reservoir will typically require a shelf or support structure on top of the tank, that can hold at least 200 pounds.

Double-Pumped Drainback Systems with External Heat Exchangers (see page 24)

Double or single-pumped drainback systems with external heat exchangers are discussed thoroughly in Chapter 3. The heat exchanger principles for closed-loop glycol systems are the same for drainback systems. One unique feature of double-pumped systems with external heat exchangers is that they allow you to use two, small, inexpensive 40 or 50 gallon tanks pumped together as one. This saves you money compared to 80 or 120 gallon tanks and often allows you to use the homeowner's existing tank. See page 130.

Solar Hot Water Space Heating and/or Pool/Spa Systems

Almost all successful large space heating systems have been drainback systems. "Mr. Murphy" may visit if you use glycol systems for zoned space heating. There are serious design issues in using glycol systems for space heating - they will overheat the storage tank in the summer if there is not somewhere else to dump the heat. There are several obvious advantages drainback systems have over glycol systems for these applications. Since a drainback system is unpressurized, it is least likely to have leaks in the piping. It is my opinion that smaller glycol systems should use DC pumps and solar electric (PV) modules. In large space heating systems, AC pumps and differential thermostats should be used. If you do not get all the air out of all the pipes, solar collectors, and parts of the the water heating system, DC pumps may easily airlock. This will result in no, or inadequate circulation of liquids through the system. **The DC pumps available today cannot create the proper head and flow rate for systems with solar collector area over 96 sq. ft. with one pump.** Also systems with more than 96 sq. ft. of collector area will require 3/4" pipes, like in drainback systems.

Solar hot water and small supplemental space heating systems or pool/spa systems can be combined in drainback systems. Drainback systems are ideal for supplemental space heating. If you are worried about water freezing, add 33% glycol to the water. Drainback systems with AC controls and a high-limit feature can use the tank sensor to turn off the pump when a preset high-limit temperature is reached in storage. Space heating systems should tilt the collector at an angle of latitude plus 15°. The Taco 0013 and Grundfos UP26-116F pumps can be used with up to (12) 4' x 10's or (15) 4' x 8's in two parallel banks with 1 1/2" collector headers and 1" to 1 1/4" lines with up to four 120 gallon tanks with the heat exchangers in parallel and a 30 or 42 gallon hot water tank or two 20 gallon tanks as a drainback reservoir - see pages 26 and 27. The first 120 gallon tank's hot outlet should feed the second tank's cold inlet. The Wilmark stainless steel QHE35 pool/spa heat exchangers (see pages 186 and 187) are excellent to heat a pool or spa in the summer when space heating is no longer needed. Multiple 40 or 50 gallon hot water tanks or large 80 gallon or 120 gallon side-port Rheem/Ruud or Lochinvar solar hot water tanks can be used with large commercial drainback systems as a drainback reservoir.

Large Commercial/Residential Drainback Systems That Use the Reservoir as Storage (see page 28)

For large residential space heating systems and commercial domestic hot water for apartments, motels, or condominiums, the use of insulated nonpressurized fiberglass tanks are recommended. If these tanks are not available, then use unpressurized aerated concrete tanks that can be manufactured and insulated on site (see page 146). The lids on these tanks are vented and removable. Site manufactured copper coiled heat exchangers in the water in the reservoir transfer heat to the potable (drinkable) hot water piping or heating systems. You can site manufacture your own heat exchangers using 30 or 50 gallon steel drums to coil soft 3/4" or 1" L copper tubing in spirals around the drums to form the heat exchanger. Number 8 copper grounding wire and copper grounding rods can be used to keep the spread in the coiled pipe. In apartment buildings with high flow requirements, it may be necessary to place several of these coils in parallel to prevent pressure losses in the supply lines.

For space heating use 1.75 to 3 gallons of water storage tank capacity per sq. ft. of collector surface area. Heating water for apartments etc. with recirculation hot water systems with copper pipe running 24/7 can have as low a ratio of 1 to 1.25 gallons of water per sq. ft. of solar collector.

Make sure all penetrations in fiberglass tanks used for reservoirs, are above the water line, in the top. Self-priming pumps that can easily move air through the pump are necessary. Determining the size of heat exchanger per gallon of storage depends on several factors, such as flow rate through the exchanger, temperature difference across the heat exchanger, etc. **A good rule of thumb is to use 2.4 lineal feet of 3/4" copper tubing as a heat exchanger per 5 gallons of storage, but good sense says to cram as much coiled copper tubing into the tank as possible since its cost is minimal in relation to the total system cost.** Painting the outside of storage tanks with Lo/Mit-1 or Lo/Mit-2 radiant barrier coating will help reduce thermal radiation from the storage tank.

A 2" line feed to an apartment will require four 1" coils in parallel in the reservoir to prevent pressure drop in the lines to the apartment. Apartments that average two people per unit will require about 28.8 sq. ft. of collector per unit. To be exact, you must meter the hot water consumption or separate the gas or electric bill, to determine the consumption during the summer months when there is no space heating. If you use gas therms, remember that commercial gas boilers are only 65% efficient. So multiply 65% times the number of therms used. Commercial electric water heaters are usually 85% efficient. Remember that the solar system should not be sized for 100% of the customer's needs, sizing for 65 to 90% is far more economical since collector sizing is based on the "average day" for the site.

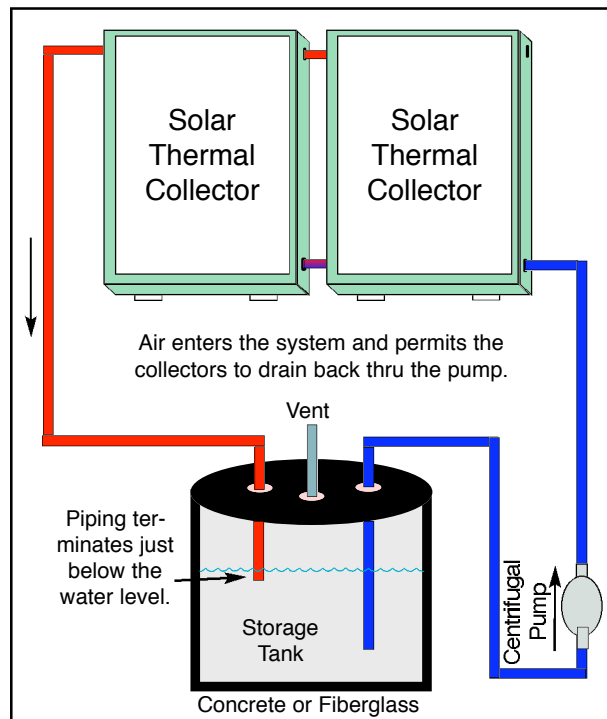

Expected water temperature will be 20°F to 25°F above the average outside temperature in a covered drain-back reservoir using unglazed plastic or copper solar pool panels.

Drainback systems must operate with three to four feet of net positive suction head, which means placing the pump well below the water level in the reservoir - the further the better. The height above sea level and water temperature also have their effects on static head. All glazed collectors must be mounted vertical with 13/32" ID or larger risers, to drain properly. **Do not penetrate a fiberglass tank below the water level. Do not order fiberglass tanks with openings below the water level.** All collector suction and return points should come into or out of the top of the tank. A sensor, like the SCR-1/2 shown on page 136, should be located toward the bottom, outside wall of the storage tank. A janitor or homeowner should check the water level once every month. A float switch can be installed to automatically add water when necessary.

The high-head pump that pulls water out of the reservoir, should be chosen based on the flow rate and lift required for the collector array, specified by the collector manufacturer. The Grundfos L Series or Sta-Rite EC or JH series rated for 240°F can be used with flat-plate collectors.

Plastic Solar Pool Panels for Large Scale Water Heating Systems In the Tropics and Sub-Tropics

Heating water with flat-plate glazed collectors is expensive, compared to using unglazed pool collectors. In tropical climates where daytime air temperatures are in the upper 80's or 90's, it would be possible to heat massive amounts of water to 115°F to 125°F with the use of unglazed pool collectors. Standard high head pool pumps and schedule 40 PVC or solid core ABS pipe could be used with copper or plastic pool panels. An automatic solar controller would sense the temperature in the bottom of the tank and compare that to the temperature in the collectors on the roof. If there was an 8°F gain, the controller would turn the pump on and start circulation. Every time the pump turns off, the water would drain back into the reservoir. A maintenance man could add water for evaporation once a month as needed. In hot tropical climates, schedule 40 PVC or solid core ABS pipe can be used with plastic or unglazed copper pool solar collectors. A normally closed vacuum breaker similar to the ones used with pool panels must be used with plastic pipe and panels. Pool pumps can be used with plastic pool panels in tropical climates. The same pumping system is used with copolymer or unglazed copper collectors as that used for heating swimming pools in temperate climates.

Unpressurized Solar Water Heating (common in Africa, Japan and Asia)

Many countries do not require the entire potable water systems to be pressurized. These systems cannot legally be installed in the US due to plumbing codes. Many countries use unpressurized water in tanks on the roof of the building or specialized pressure pumps to create water flow and pressure. This is common for recreational vehicles, boats, and planes. If direct water is used from a raised tank or reservoir on the roof, or if a secondary pressure pump is used, then a float switch would be necessary to add water for the unpressurized drainback reservoir. A pressurized pump could be used to take hot water out of the reservoir on demand. One could have a reservoir on the roof using direct gravity pressure or by pumping water to a tower, to provide water pressure. This direct utilization of unpressurized water would work in areas such as countries in the Caribbean for apartment complexes, tourist resorts, hotels, etc.



Checklist for Drainback Systems

Date: _____ Time: _____ Solar %: _____ Air Temp: _____

Collector Manufacturer's Model and Size: _____

Type and Number of Collectors: _____

Storage Tank Manufacturer's Model and Volume: _____

Original Installation Date: _____

_____ 1. Check both sensors for ohms resistance temperature

Top sensor: _____ ohms reading; Temperature: _____

Bottom sensor: _____ ohms reading; Temperature: _____

_____ 2. Use applied heat or cooling to test sensors to check controller function and pump

_____ 3. Check water level in the drainback tank - add water if necessary

_____ 4. Check flow rate on the flow meter GPM: _____

_____ 5. Record Thermometer Temperature

Option A:

Collector temperatures on the feed _____ and return line _____

Option B: double-pumped or Thermosyphon

Water temperature on the inlet to the heat exchanger _____
and exit _____

_____ 6. Check insulation on the roof and clean the glass

_____ 7. (Optional) On a double-pumped thermosyphon system with a PV module on the water-side, check PV module amperage _____ voltage _____
time of day _____ and sky conditions _____

_____ 8. (Optional) Change Cuno Anti-scale filter

Notes: _____