

## I. GLASSWARE TECHNIQUES AND ACCESSORIES

Equipment made of glass or using glass components has applications in all branches of science. This chapter includes some basic glass-working techniques that will be necessary for constructing much of the equipment in this book.

These are presented in sections which describe the type of equipment needed, the type of glass to use, and techniques for working with several forms of glass.

### A. BURNERS, TOOLS, AND EQUIPMENT

This section discusses burners that can be used in working glass, as well as listing the tools and other items necessary for working with glass.

### B. GLASS

This section describes the type of glass that works best with the burners listed in section A.

### C. SAFETY

Notes for safe handling and working of glass are given here.

### D. PROCEDURES FOR GLASS TUBING AND RODS

Directions for working with glass tubing and solid rods are given in this section.

### E. GLASS SHEET OPERATIONS

This section tells how to cut and drill glass sheets.

### F. BOTTLE AND JAR TECHNIQUES

Much useful laboratory glassware can be made by using discarded bottles and jars. This section includes directions for cutting and drilling these items.

### G. STOPPERS

This section discusses types of stoppers and describes techniques for drilling holes in them.

A. BURNERS, TOOLS, AND EQUIPMENT

Glass-working techniques described here are designated for use with Modified Alcohol Burner (II/B2), and the Gas Burner (II/C2). Of these, the gas burner, if available, is most highly recommended.

The general items required for general glass-working techniques are as follows:

Glass Cutter

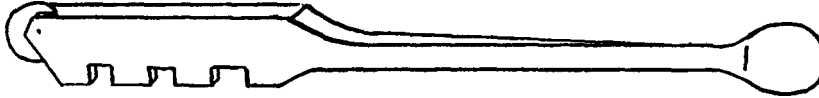

Triangular File



Round File



Set of Cork-borers

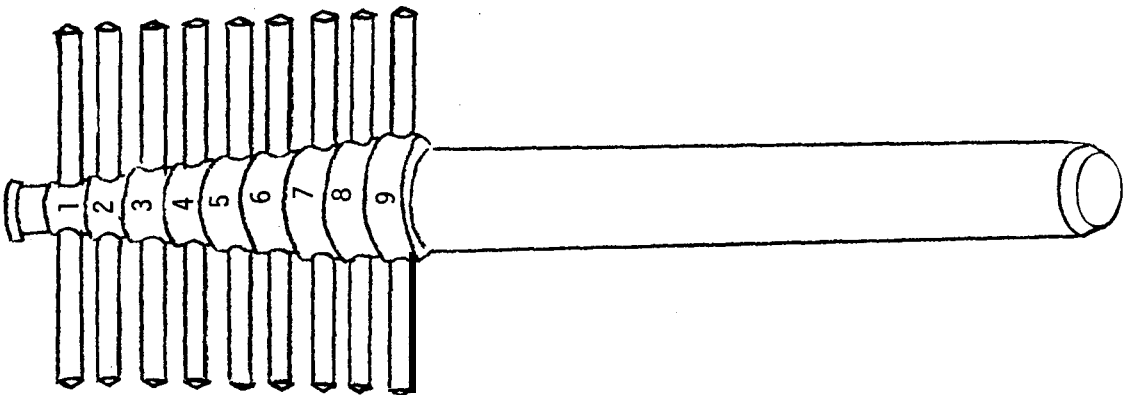

Pliers

Brick or Asbestos Pads

Rags or Pieces of Cloth

Clean rags, or pieces of cloth no smaller than about 10 cm x 10 cm.

String

Kerosene

Camphor

Ruler

Blotting Paper or Paper Towels

Emery Paper

Container of Sand



## B. GLASS

There are many different types of glass, with different properties, depending upon the chemical composition of the glass. Two very common types of glass that are discussed here are "soft glass" and "hard glass."

### Soft Glass

This term includes a number of the oldest known and most common types of glass in general use. Most bottles, jars, window glass, and much glass tubing and rods are made of some type of soft glass. Such glass is used for items of simple design and moderate thickness, that will not be subjected to very high temperatures.

One of the most important properties of soft glass, from the point of view of this book, is that it can be softened in the heat of an air-gas flame. This is the type of flame produced by the burners specified in section A. Also, soft glass has a wide range of working temperatures, which makes it easy to work even after it has been removed from flame.

Although it is easy to work, soft glass has some limitations and must be used with care. An empty container of soft glass cannot be greatly heated, or it will crack. If, however, such a container holds a liquid or powder, it can safely be heated, slowly. Also, a soft glass container, with or without anything inside, must not be suddenly cooled when hot or suddenly heated when it is cold. Otherwise, it will break.

### Hard Glass

Hard glass has been developed during the twentieth century. Of a number of types produced, "Pyrex" is one of the most common brand names. Most manufactured laboratory glassware is now made of hard glass, which is harder stronger, more chemically inert, and safer to use over a wider temperature range than soft glass.

Laboratory glassware made of hard glass is safer than soft glass. It can be rapidly heated or cooled to greater temperature extremes without danger of breaking. It does not scratch easily, and it does not break as easily as soft glass if struck or dropped.

Although it is often manufactured into laboratory glassware, hard glass is not generally made into the bottles and jars that are used for much of the apparatus described in this book. Therefore, it is not as generally available as soft glass. As tubing, rods, and sheets, it is usually more expensive than the same items made of soft glass.

Hard glass's most important disadvantage here is that it must be worked in an oxygen-enriched flame. The burners described in section A cannot heat hard glass hot enough for working.

Therefore, only soft glass is suitable for use with the alcohol or gas burners

described. The techniques here listed have been tested using soft glass and the air-gas flames produced by such burners.

Testing for Soft Glass

To determine whether a piece of glass is "hard glass" or "soft glass", heat it in the flame of an alcohol or gas burner. If the glass begins to glow and soften enough to be easily worked, it is soft glass. If it does not soften, it is hard glass and cannot be worked without specialized equipment.

### C. SAFETY

Glass working, like most other laboratory procedures, carries a set of risks. By arranging a safe work area and taking a few precautions, however, most such risks can be avoided.

#### Sharp Edges and Points

There is always a danger of being cut by sharp points and edges of broken or cut glass. Be careful of such edges and points, and try to handle the glass away from the edges. Fire polish or smooth with emery paper any cut edges or points that are part of a finished project. Keep such edges away from the mouth and eyes at all times, and keep the work area clear of waste glass.

#### Burns

Hot glass looks just like cool glass! To avoid burns, allow heated glass to cool before handling it. Rest it on bricks or asbestos pads, or in a container of sand. Before picking up a piece of previously heated glass, touch it lightly with the fingertips to check that it is cool enough to handle. In cases where hot or warm glass must be handled, protect the hands with a holder of several layers of cloth, or use holders such as those described in the section on holders(IV). Protect the body from burns with clothing, an apron, overall, or laboratory coat.

#### Fire

Both the burner flame and hot glass can start a fire. Prevent this by keeping all flammable material, such as paper or cloth away from the flame and any hot glass. Set hot glass down on things that will not burn, such as bricks, asbestos pads, or sand. To keep hair or clothing from being singed or igniting, tie back long hair, roll up sleeves, and secure loose clothing close to the body. Inspect the burner, fittings, tubing, and fuel supply each time the equipment is used to prevent leaks of fuel that might lead to a fire. If any alcohol should spill, immediately put out the flame and mop up the spill.

The container of sand mentioned for holding hot glass is also useful for fire control. If paper, cloth, or spilled alcohol should ignite, smother the fire by dumping sand on it. If on the other hand, the gas burner system (II/Q) is used and a fire develops, get away fast!

#### Eye Damage

To prevent eye damage, keep all sharp edges and points, all hot glass, and all flames away from the eyes. Wear safety goggles or eye glasses to provide additional protection for the eyes.

Gas Danger

If natural gas or bottled gas is used as fuel for the burner, a leak in the system can release gas that is poisonous to breathe. To avoid this danger, inspect all pipes, tubing, and fittings often.

5  
0  
R

10

1

D. PROCEDURES FOR GLASS TUBING AND RODS

D1. Cutting

a. Materials Required

Length of soft glass tubing or solid rod

Triangular file

Ruler

b. Procedure

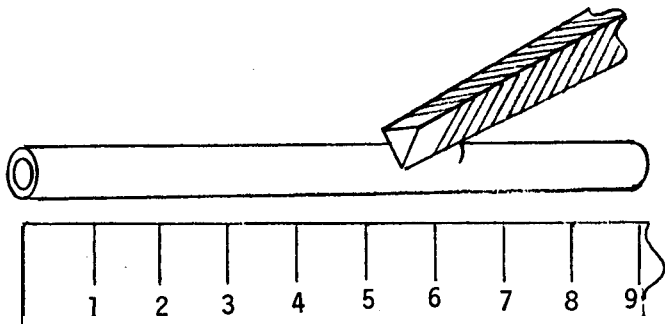

Lay the tubing or rod flat on the work surface and measure the desired length. Make a scratch on the glass at this point by drawing one edge of the file across the tube. Press hard enough with the file to make a deep scratch.

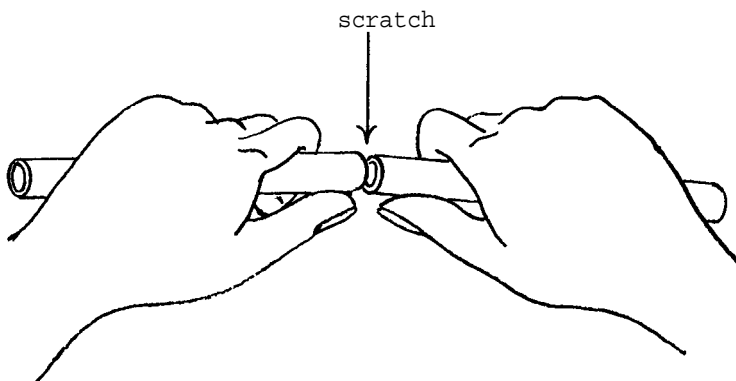

Moisten the scratch, then grasp the glass firmly in both hands with the thumbs on the side of the tube opposite the scratch. Apply pressure with the thumbs while pulling out and down with the hands until the tube or rod snaps cleanly.



## D2. Bending

### a. Materials Required

Burner: wide-flame alcohol burner

or

wing tip with gas burner

Length of soft glass tubing or solid rod

Cooling surface: brick

or

asbestos pad

### b. Procedure

#### Gravity Bending

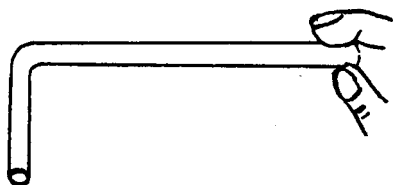
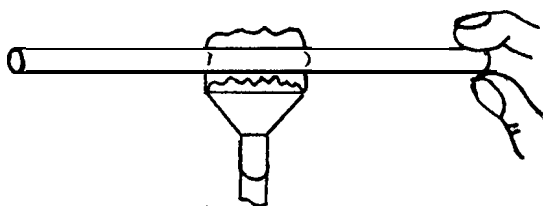

With one hand, hold the tubing or rod, just above the inner cone of the flame. Rotate the tubing to heat it evenly until the free end droops under its own weight.

Remove the glass from the flame. It should bend to a right angle. Allow it to cool.

#### Manual Bending

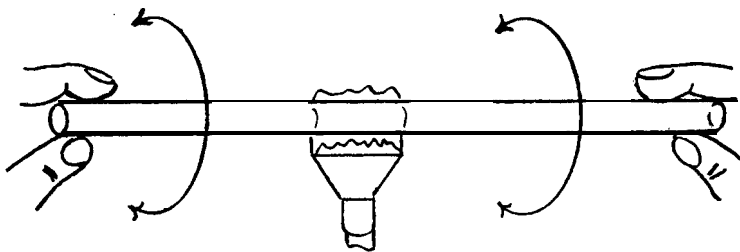

Install the wing tip on the gas burner, and light the burner. Hold each end of the tubing or rod. Support the glass so that it is level, with its middle in the hottest part of the flame. Turn the tubing or rod back and forth by rotating the thumb and first finger. Continue to heat it evenly until it softens.

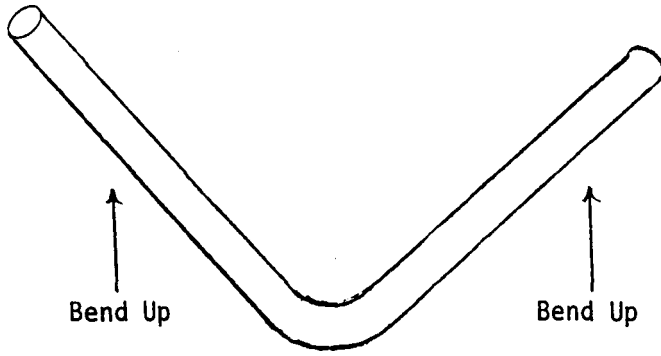

When the tubing or rod is soft, remove it from the flame. Immediately, bend the ends up until the tubing or rod is bent at a right angle (90').

Rest the hot tubing or rod on a brick or other cooling surface.

C. Notes

(i) If a wing tip is not available or if a standard alcohol burner is used, the tubing or rod must be heated differently. Hold each end of the glass and support it so that it is level with the middle just above the inner core of

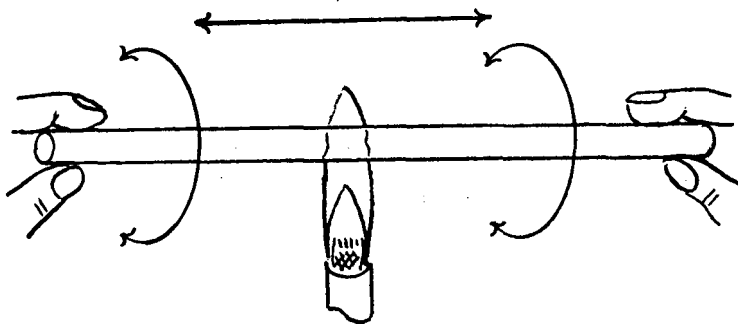

flame. Rotate the tubing back and forth. At the same time, move it to the left and right so that about 0.3 cm of its length of evenly heated. Continue to both rotate and move the tubing or rod until the heated section softens.

Remove from the flame and bend it as described above.

Remove from the flame and bend

(ii) With a little practice with glass tubing, you should be able to achieve a

bend in which the opening stays the same throughout the bend.

Overheating or underheating the tubing, however, will produce poor bends. Underheating causes the tube to fold in at the bend. Overheating causes the tube to collapse at the bend.

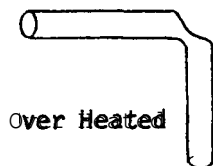
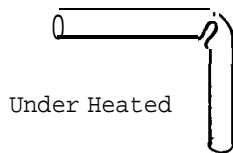
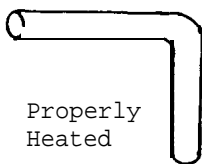

- (iii) If a U-shaped bend is desired, first make one 90° bend as described above. After allowing the glass to cool, make another 90° bend near the first one.

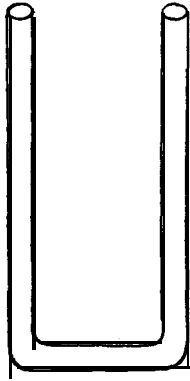

100

100

D3. Stretching

a. Materials Required

Burner: wide-flame alcohol burner

or

wing tip with gas burner

Length of soft glass tubing or rod

b. Procedure

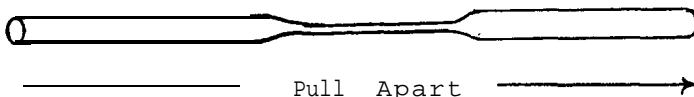

Hold the glass tubing or rod in the flame. Turn it as it heats, just as for making a bend. Heat the glass evenly until it softens. When the tubing or rod is soft, remove it from the flame. Pull the ends apart until the center has become narrow and stretched about 25 - 30 cm.

After the stretched part has cooled, it can be cut as required (I/D1). Carefully fire polish the edges (I/D4).

c. Notes

(i) Stretched glass tubing has many applications in laboratory glassware. For example, the ends of the stretched tubing pictured above, with a narrow opening at

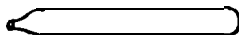

one end, may be used as nozzles or jets.

The very narrow section of the tubing, the stretched part, may be used as a capillary tube.

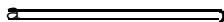

lary tube.

(ii) If a wing tip or wide-flame burner is not available, follow the procedure given for heating a wide area of glass without the wing tip [I/D2, Note (i)].

D4. Fire Polishing Tubing

a. Materials Required

Glass tubing with cut edge

Burner

Cooling surface

b. Procedure

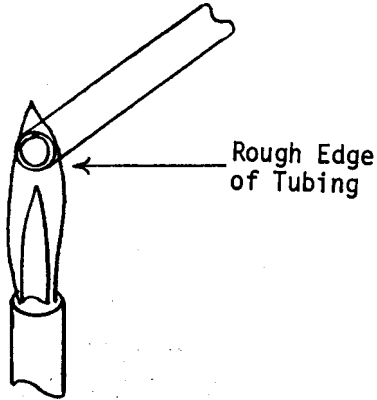

Hold the rough, cut end of the glass tubing in the hottest part of the flame, just above the inner cone. Turn the tubing constantly until the edge glows red.

Remove the tubing from the flame. Examine the heated end. If it is now rounded smoothly, rest the hot tubing on a brick, asbestos pad, or sand to cool. If the other end of the tubing is also rough, repeat the fire polishing procedure.

c. Notes

- (i) Do not overheat the end of the tubing, or it will tend to close entirely.
- (ii) Fire polish the ends of all glass tubing in use, as a safety measure.
- (iii) Tubing with thick walls--for example, 0.5 cm (inside diameter) and larger--must be annealed to prevent cracking. To do this, hold the end in the flame for about one second, then remove from the flame for about one second. Repeat this procedure eight or ten times, then hold the end in the flame, turning it constantly until it is red hot. To cool thick-walled tubing slowly, remove it from the flame, but hold the tubing near the flame for a few seconds. Gradually move the hot end of the tubing further from the flame until it can be rested on the brick or other cooling surface.

D5. Closing Tubing

a. Materials Required

Burner

Glass tubing

Cooling surface

b. Procedure

Narrow Tubing

When using tubing with a diameter of less than 1.0 cm, hold the end of the tubing in the hottest part of the flame, just as for fire polishing. Turn the tubing constantly. Continue heating until the end closes.

Wide Tubing

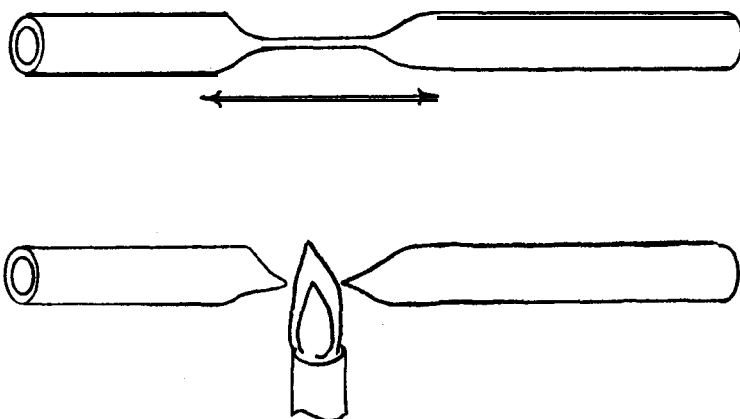

When using tubing with a diameter greater than 1.0 cm, heat the tubing near one end, rotating the tubing as it heats. When the tubing is soft, pull it apart.

Continue to heat and pull the ends apart until the ends separate and the pointed end has closed.

D6. Glass Blowing

a. Materials Required

Gas burner

Length of soft glass tubing

Cooling surface

b. Procedure

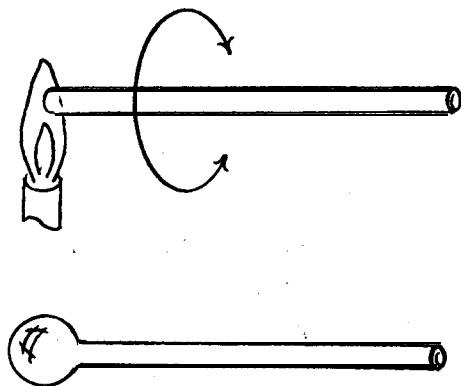

Fire polish one end of the tubing. Allow it to cool. Close the other end by heating in the flame. Heat the closed end, rotating it constantly. While continuing to heat and rotate the tube, blow very gently, in short, light puffs, into the open end of the tube. Just as the closed end of the tube begins to swell and glow pale red, remove it from the flame. Blow strongly into the tube, while rotating it, to form a small round bulb.

c. Notes

(i) This procedure takes practice and patience to learn. It is helpful to begin with the narrowest tubing available; 0.3 cm tubing, for example. A common problem is blowing out the side of the bulb while the tubing is still in the flame.

(ii) A limiting factor in the size of tubing that can be used and the size of the bulb that can be blown is the burner used. The gas generating system

(II/C) and burner (II/C2) are adequate to allow 0.3 cm and 0.5 cm tubing to be blown into bulbs about 0.8 cm in diameter.

D7. Making Rim in Tubing

a. Materials Required

Burner

Glass tubing

Triangular file

Brick, or asbestos pad

b. Procedure

Flattening

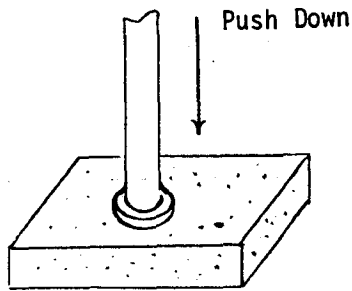

Hold one end of the tubing in the hottest part of the flame. Turn it constantly until the edge glows red. Remove the tubing from the flame. Quickly push the hot end evenly down against the brick or asbestos pad. A lip should form. Allow the glass to cool.

Flaring

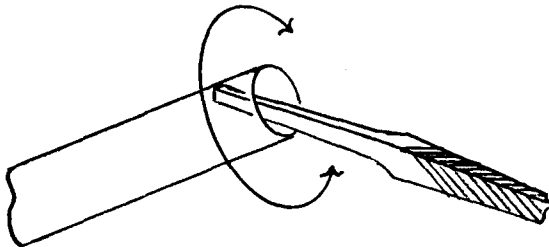

Heat one end of the tubing until it is red hot. Remove the tubing from the flame. Hold the thin handle end of the file inside the end. Press gently outward on the file, while turning the tube to form a flared edge. Allow the glass to cool.



D8. Finishing Ends of Rods

a. Materials Required

Soft glass rods

Burner

Brick, or asbestos pad

Pliers

b. Procedure

Fire Polishing

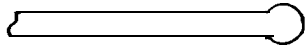

Follow the procedure for fire polishing glass tubing (I/D4). It will be necessary to heat the end of the rod for a longer period of time. The fire polished end will have a small, solid bulb. Holding the rod in the flame for a longer time will produce a larger bulb at the end.

Allow the rod to cool.

Flattening

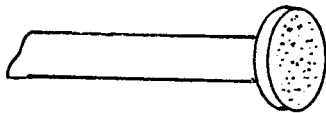

Follow the procedure for flattening glass tubing (I/D7) to form a flat disc at the end. Allow the rod to cool.

Squeezing

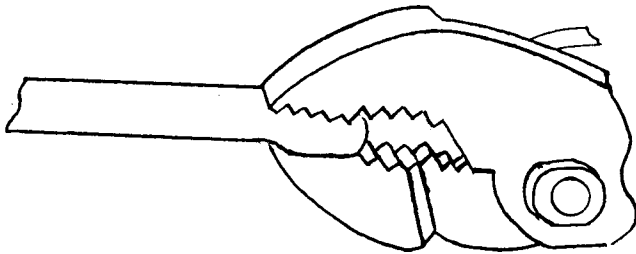

Heat one end of a rod as before. When it is hot, remove it from the flame. Compress about 1 cm of the end of the rod between the jaws of the pliers. A flattened paddle-shaped end will form.

Allow the rod to cool.

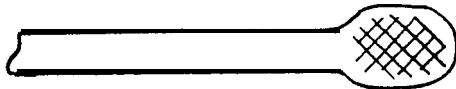

C. Notes

(i) A useful stirring rod can be made with a rod of about 0.3 - 0.5 cm diameter, 15 - 20 cm long. Flatten one end and squeeze or fire polish the other.

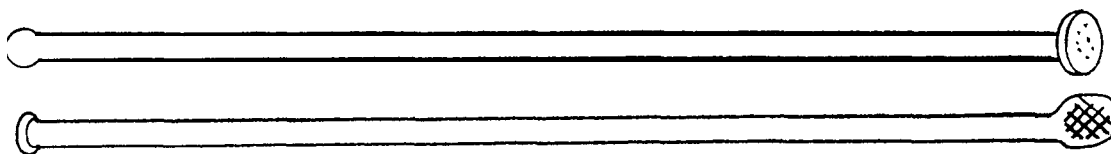

E. GLASS SHEET OPERATIONS

El. Cutting

a. Materials Required

Glass cutter

Sheet of glass

(for example, a pane of window glass)

b. Procedure

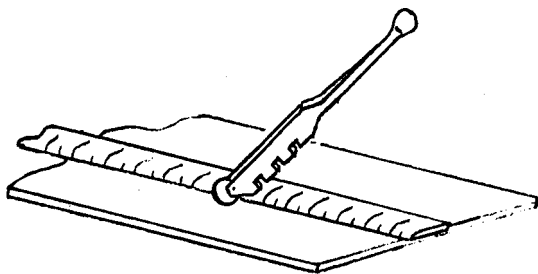

Lay the glass flat on bench of table. Hold the ruler along the line to be cut, with one hand; and with the other hand, draw the wheel of the glass cutter on the glass along the ruler. Press hard enough to scratch the glass.

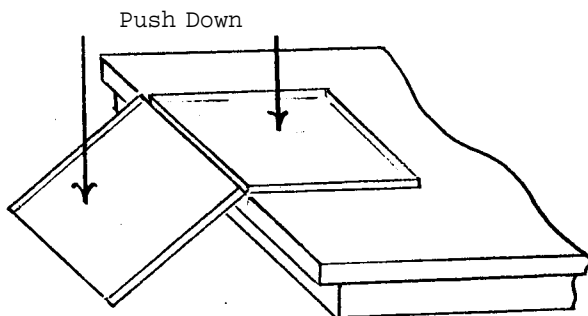

Place the underside of the scratch exactly over the edge of the table or bench. Press down on both sides to break the glass cleanly along the scratch.

E2. Drilling a Hole

a. Materials Required

Sheet of glass

Triangular file

Hammer

Turpentine

Camphor

b. Procedure

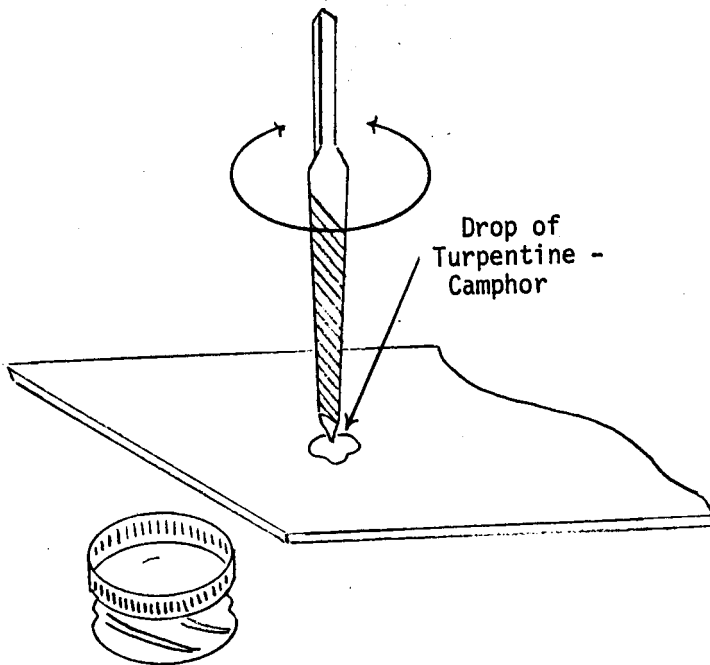
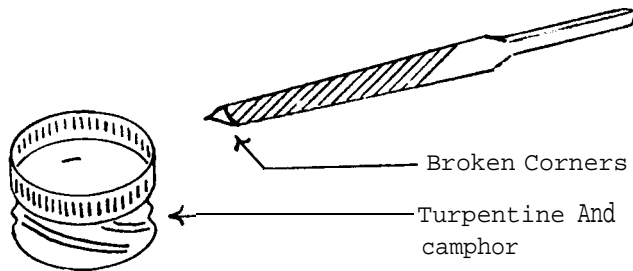

Take a little turpentine in a bottle cap. Put a small amount of camphor in it. Chip off the end of the triangular file with a hammer. This chipped end has sharp corners.

Place the glass flat on a table. Dip one of the sharp corners of the broken file into the turpentine-camphor mixture.

Press this corner of the file down on the spot to be drilled. Twist the file back and forth to drill into the glass. Use more turpentine-camphor as needed and continue drilling until the hole is complete.

c. Notes

- (i) Drilling by hand is slow and may take ten or fifteen minutes.
- (ii) A completed hole can be enlarged with the edge of the triangular file or a round file, and the turpentine-camphor mixture.
- (iii) After making the beginning hole on the surface of the glass, it is in fact easier to use a hand drill with the triangular file as the bit. However, extreme care must be taken. Do not push down on the drill at all, or the glass might break. Let only the weight of the drill be the force on the glass.
- (iv) Follow this same procedure to drill a hole in a glass bottle or jar.

F. BOTTLE AND JAR TECHNIQUES

Fl. Etching

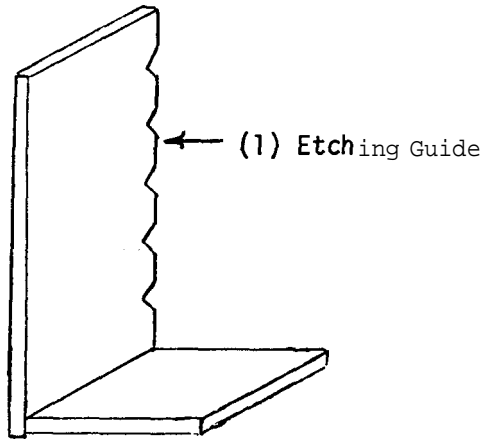

a. Materials Required

<u>Components</u>	<u>Qu</u>	<u>Items Required</u>	<u>Dimensions</u>
(1) Etching Guide	1	Wood (A)	Approximately 10 cm x 20 cm x 1 cm
	1	Wood (B)	Approximately 10 cm x 10 cm x 1 cm

b. Construction

(1) Etching Guide

Cut V-shaped notches into one edge of a wooden board (A). Make the notches about 1 cm deep and about 2 cm (or other desired interval) apart. Then secure the base (B) at right angles to (A) with nails or glue and screws.

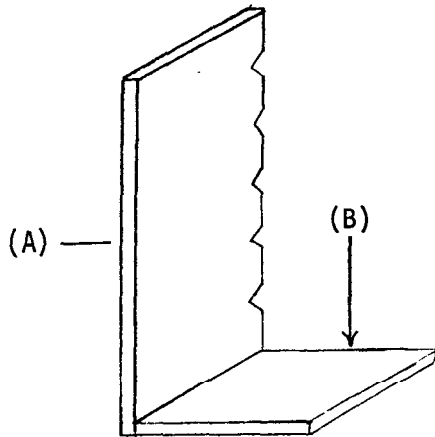

c. Notes

(i) The etching guide is used in combination with a triangular file or glass cutter to scratch a continuous line on a bottle or jar, prior to cutting. The

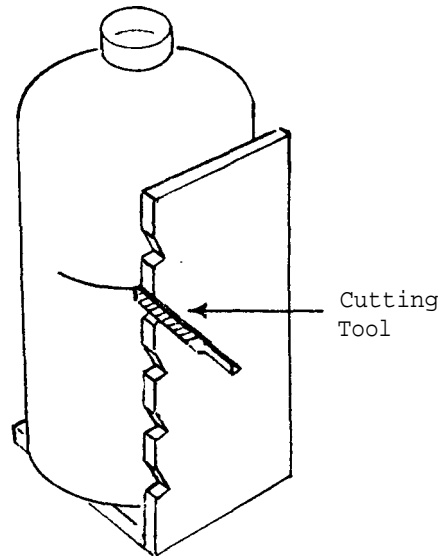

bottle or jar is placed on the stand and a glass cutter or triangular file is placed in a notch at the desired height. The bottle is rotated, and pressure is maintained against it with the tool so that a continuous scratch is scored around it.

(ii) A second method for etching a bottle, jar, light bulb, etc. to be cut is to wrap a strip of adhesive tape or paper around the glass as a guide. After the line has been scratched completely around the glass, the tape is removed.

(iii) After the glass has been etched in either of these two fashions, it may be cut using one of the techniques described in the following section.

F2. Cutting

Electrical Heating

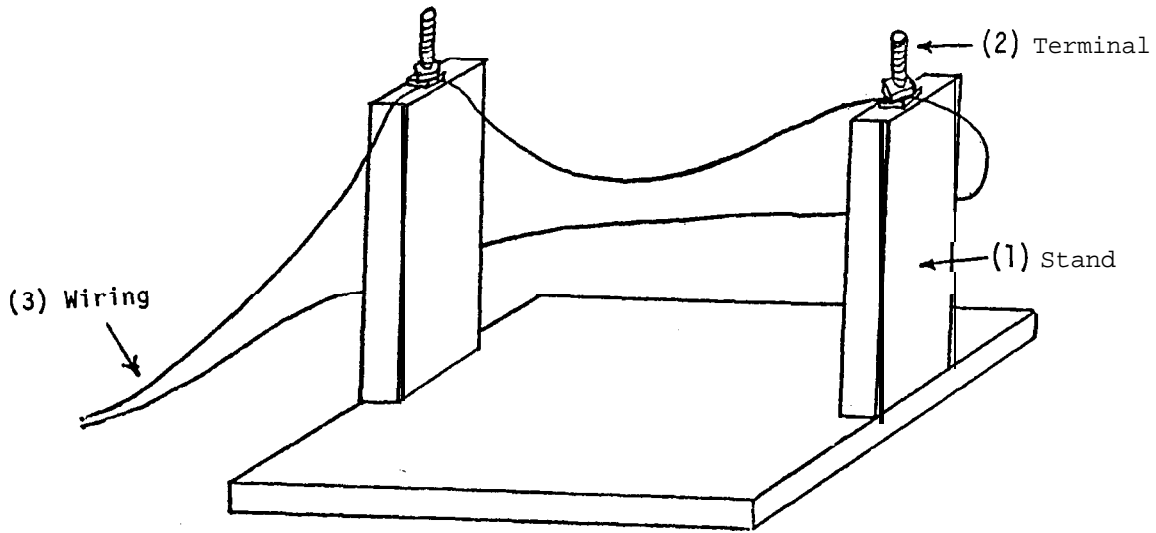

a. Materials Required

<u>Components</u>	<u>Qu</u>	<u>Items Required</u>	<u>Dimensions</u>
(1) Stand	1	Wood (A)	30 cm x 10 cm x 2 cm
	2	Wood (B)	25 cm x 4 cm x 2 cm
(2) Terminal	2	Bolts (C)	3 cm long, 0.5 cm diameter
	4	Nuts (D)	0.5 cm
(3) Wiring	1	Nichrome Wire (E)	Size #24 (0.06 cm diameter), 34 cm long
	2	Insulated Copper Wire (F)	Size #20 (0.08 cm diameter), 125 cm long

b. Construction

(1) Stand

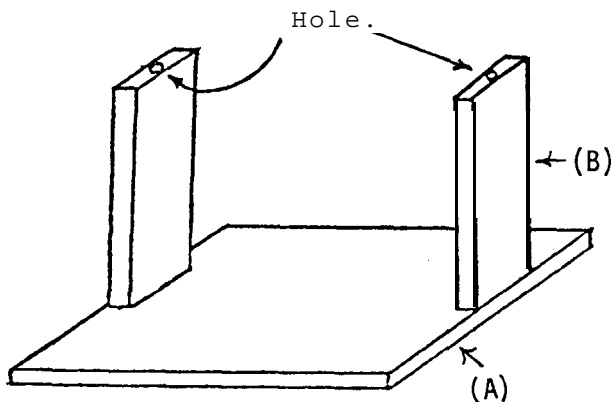

Drill a hole in one end of each of the two uprights (B). This hole should be slightly smaller in diameter than the bolts (C) used for the terminals. Next, nail or screw the uprights to the base (A).



(2) Terminal

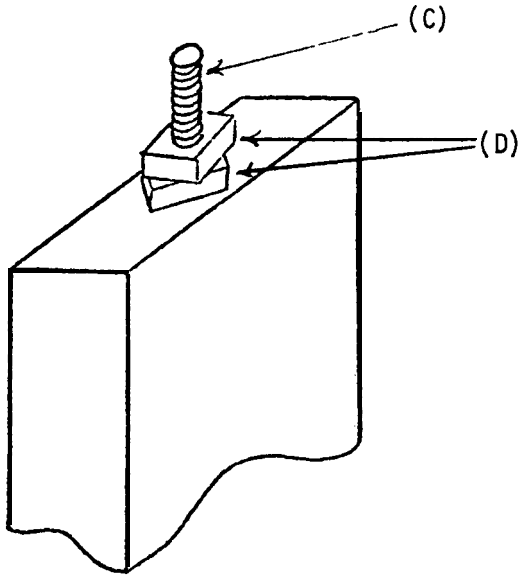

Cut the heads off the two bolts (C), and put glue into the holes in the uprights (B). Screw the bolts down into the hole, leaving about 1.5 2 cm protruding. Next, secure the bolts by screwing on one nut (D) until it is tight. Screw on the second nut (D) loosely.

(3) Wiring

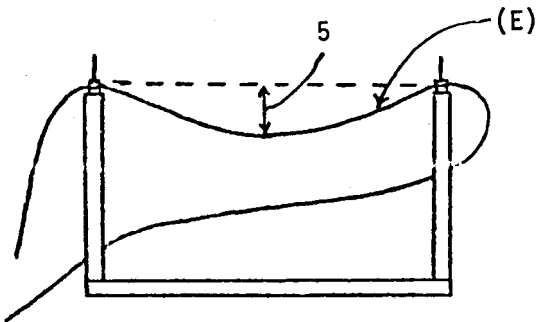

Wrap **one end of the #24 nichrome wire (E) around one bolt (C)** for one or two turns and do the same with the other end. Tighten the second nut (D) on the terminals until the nichrome wire is firmly held. There should be about a 5 cm sag in the middle. Fasten the copper wires (F) to each terminal in the same manner. Connect clips to these wires. For power use a transformer (PHYS/VII/A2) wired to a wall outlet [Note (iii)], or a heavy-duty battery.

C. Notes

(i) Prepare the jar, bottle, light bulb, etc., to be cut by etching a continuous line around the glass (I/F1). Connect the cutter to a power supply until the wire is hot, then place the etched line on the hot wire, Hold the glass in this position until it cracks along the heated portion. Then rotate the glass to heat another portion of the etched line. Continue this procedure until the crack has

circled the glass and the two sections separate.

(ii) The broken edges of the glass can be smoothed by rubbing them with wire gauze or wet sandpaper (emery paper).

(iii) If the wire cutter is used with a wall outlet (120 volt) then a transformer must be employed to bring the voltage down to 12 volts, 3 amps. The cutter can also be used with a standard 12 volt automobile battery. However, using a battery requires more time for heating the etched line, since the wire does not get as hot.

### String Heating

#### a. Materials Required

Bottle, jar, or light bulb  
String  
Container of cold water  
Alcohol, kerosene, or turpentine  
Tape or paper  
Glass cutter or triangular file

#### b. Procedure

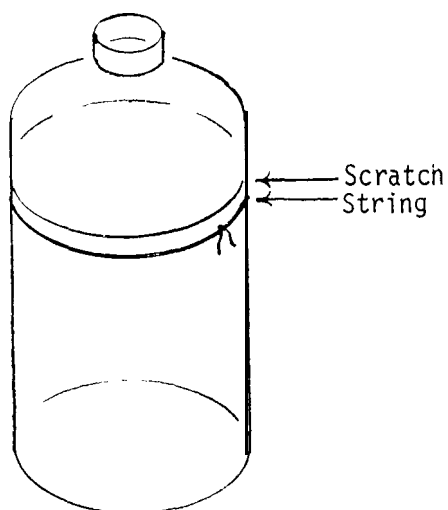

Prepare the bottle or jar as described in I/F1 above. After the paper or tape guide has been removed, tie a piece of string or cord which has been soaked in a flammable liquid around the bottle about 0.5 cm below the scratch. Light the string with a match, and as soon as the flame dies down, pour cold water on the bottle. The sudden change from hot to cold will break the bottle along the scratch. This process may have to be repeated to break thick glass. Smooth the cut edge of the glass as described in Note (ii) above.

### Wet Paper Cooling

#### a. Materials Required

Bottle, jar or light bulb  
Alcohol or gas burner, or candle  
Triangular file or glass cutter  
Blotting paper or wrapping paper  
String  
Container of cold water

b. Procedure

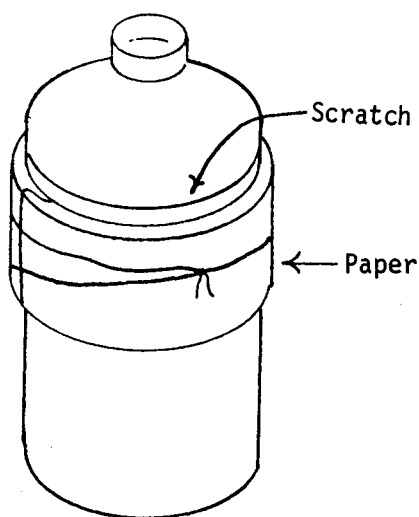

Wind a strip of blotting paper, paper towel, or wrapping paper about 5 cm wide around the bottle at one side of the line to be cut. Wrap the paper at least 0.5 cm thick and then tie the paper with string or rubber bands. With the file or glass cutter, scratch a line completely around the bottle at the top edge of the paper. Put the bottle into cold water until the paper is soaked (about five minutes). Remove the bottle from the water, and rotate it in a horizontal position, with the scratch on the glass just above a small, fine flame. Continue this for four or five minutes. If the bottle has not dropped apart, put the bottle vertically into the water. The bottle should break into two parts along the scratch. If it does not, repeat the heating and cooling until it does. It is crucial that the flame be very small so as to heat a minimum of glass on either side of the scratch.

C. Notes

- (i) To drill a hole in a glass bottle or jar, follow the procedure outlined for drilling in a glass sheet(I/E2).

G. STOPPERS

Stoppers for use in scientific apparatus are commonly manufactured of either cork or hard rubber.

Rubber Stoppers

Rubber stoppers are more durable for general use than cork stoppers. They are available in standardized sizes, and are manufactured with no holes as well as with one, two or three holes. Although they tend to react with organic solvents like gasoline, they provide an excellent seal in most cases and can even be sterilized. (BIO/VII/A2). If a stopper with holes is specified in the directions for a piece of apparatus, use rubber stoppers with pre-drilled holes if at all possible. If it becomes necessary to drill a hole or holes in a rubber stopper, consult the notes following the discussions of boring and drilling holes in cork stoppers(I/G1 and G2).

Cork Stoppers

Cork stoppers, while generally less expensive than those made of rubber, are not as suitable for general use. They tend to lose their shape after long use, are not available with holes pre-drilled, tend to absorb reagents, and cannot be adequately sterilized. Should it be necessary to bore a hole or holes in a cork stopper for the insertion of glass tubing, one of the following methods may be employed.

Gl. Cork Boring

a. Materials Required

Cork stopper

Set of hand cork borers

b. Procedure

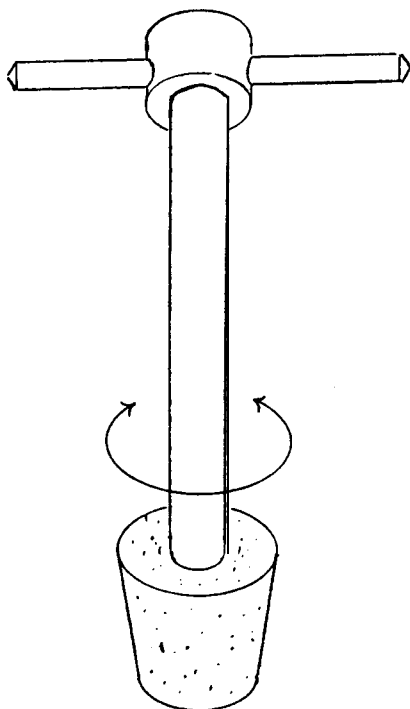
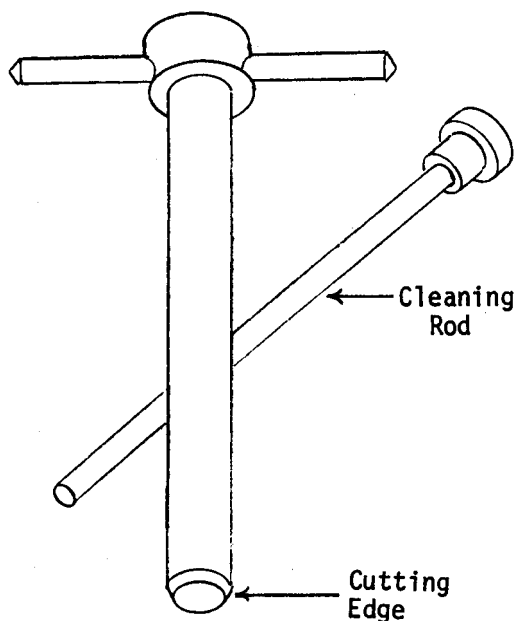

If a set of hand cork borers in graduated sizes is available from a scientific supply house, choose a cork borer of the same or slightly smaller diameter as the glass tubing that is to go through the cork.

The cork borer set generally is supplied with a rod to clean pieces of cork out of the borer. Soften the cork by wrapping it in a piece of paper and rolling it gently on the floor under your foot.

With one hand, hold the cork firmly on the table or bench, wide end up. With the other hand, place the cutting edge of the cork borer in the center of the cork. Then with a gentle twisting motion on the cork borer, bore into the cork until the tool is about halfway through the cork.

It is not necessary to push hard; but twist gently with light pressure. Remove the cork borer from the cork and push out small pieces of cork inside it with the cleaning rod.

Turn the cork over and repeat this process until there is a hole through the cork.

C. Notes

(i) If two holes are desired, the first must be bored near one edge of the cork in the manner described above.

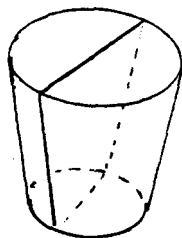

The second hole is then bored in the same way. A guide line, drawn around the middle of the cork, is helpful in determining the positions of the two holes.

(ii) This method is suitable for boring holes in rubber stoppers. However, the stopper as well as the end of the boring tool should be lubricated with glycerine.

## G2. Cork Drilling

### a. Materials Required

Cork stopper

Round file

Cloth, or wooden handle

Burner

Brick or asbestos pad

### b. Procedure

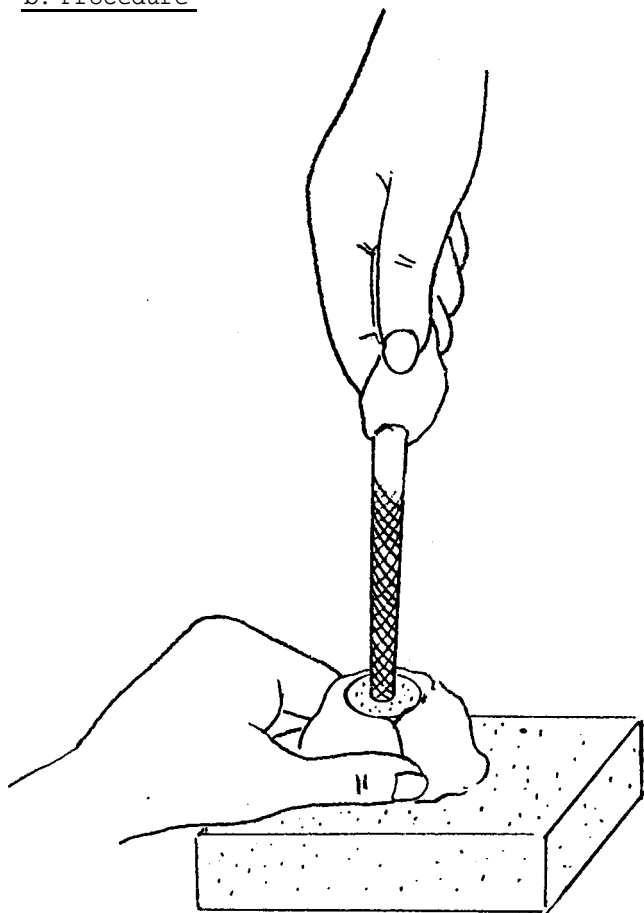

Soften the cork as described in I/G1 above. Hold the cork, wrapped in cloth or clamped in pliers, securely against the brick or asbestos pad with one hand. Hold the file, wrapped in cloth or in a wooden handle, by its four-sided end in the other hand. Heat the round end of the file in the burner flame. Remove the file from the flame when it glows red hot, and push it gently into the center of the cork. Push it only about half-way through the cork, then remove it.

Turn the cork over, reheat the file, and make another hole to meet the first one.

Allow the file to cool, then enlarge the hole to the desired size by gentle filing.

### c. Notes

Care must be taken not to overheat the file, or it may set the cork on fire. Should this happen, blow the flame out quickly.

(ii) Two holes can also be made through the cork with this method.

(iii) Very small holes can be made in corks in the same manner by using heated wire.



(iv) If a hand drill or electric drill is available, holes can easily be bored by using either a regular drill bit or the round file as the drill bit, The cork must be rigidly held in a vise. For an accurate hole, just as with the other methods of drilling, a hole should be drilled halfway through the cork from each side, to meet in the center of the cork.

(v) It is possible to drill holes in rubber stoppers with a hand drill or electric drill, but the hot file method will not work in rubber stoppers.

### G3. Inserting Glass Tubing Through a Stopper

#### a. Materials Required

- Glass tubing
- Burner
- One-hole cork or rubber stopper
- Cloth
- Glycerine

#### b. Procedure

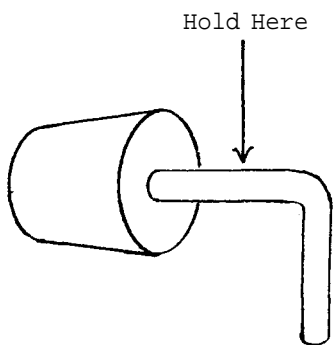
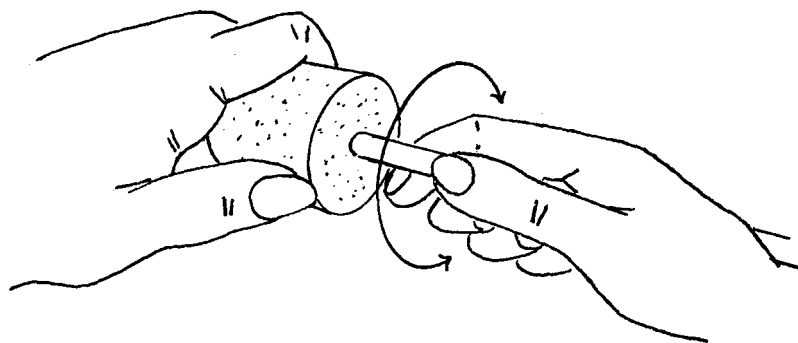

Fire polish the end of the tube that is to go into the stopper. Allow it to cool. Hold the tubing about 2 - 3 cm from the fire-polished end in one hand. Lubricate this end of the tube with glycerine. Hold the stopper in the other hand. Gently and carefully push the tube into the stopper with a twisting motion. Do not use too much force or the tube will snap.

When pushing a piece of bent tubing into a stopper, always hold the tube between the bend and the stopper. Do not push on the bend; it is weak and will break easily.

#### c. Notes

(i) This is a technique that, if improperly done, can be quite dangerous. When done correctly, however, it is quite safe.