

X. MOLECULAR MODELS

Four types of models to assist in the instruction and understanding of molecular structure are described.

A. SPACE-FILLING MODELS

These roughly represent relative sizes and positions of atoms within a molecule.

B. SKELETAL MODELS

These models more accurately represent atomic radii and bond angles than do those in the previous section.

C. CRYSTAL MODELS

These are three-dimensional models that represent shape and atomic packing within crystals.

D. KINETIC-MOLECULAR MODEL

This two-dimensional model demonstrates the kinetic theory of matter.

A. SPACE-FILLING MODELS

Al. Ball-and-Stick Models

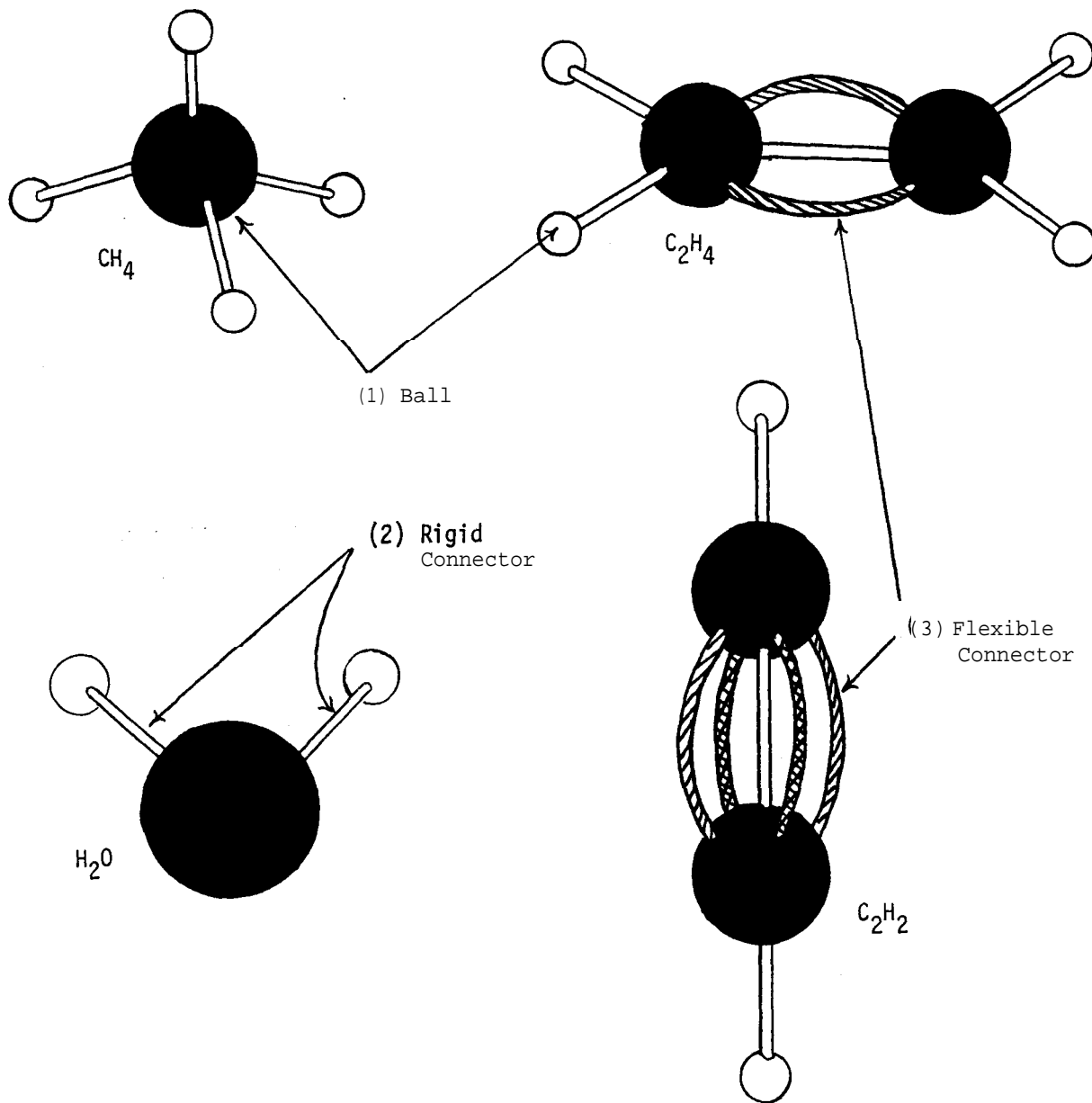

a. Materials Required

<u>Components</u>	<u>Qu</u>	<u>Items Required</u>	<u>Dimensions</u>
(1) Ball	1	Block of Styrofoam Plastic or Foam Polystyrene (A)	Approximately 4 cm x 10 cm x 10 cm
	1	Electric Bottle Cutter (B)	(I/F2)
	1	Thin Nichrome Wire (C)	0.02 cm diameter, 35 cm long

- (2) Rigid Connector 1      Box of Toothpicks (D)      Approximately 250
- (3) Flexible Connector 1      Package of Pipe Cleaners (E) Approximately 25

b. Construction

(1) Ball

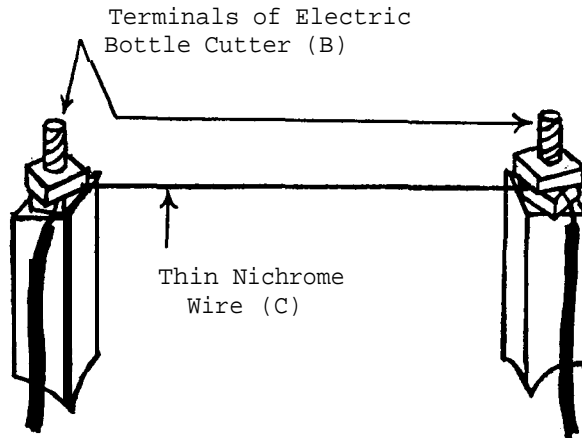

Construct the electric bottle cutter (B) according to directions given in (I/F2). Substitute the thin nichrome wire (0.02 cm diameter) for that described and stretch it tightly between the terminals, Connect the terminals to a six volt battery or a transformer that steps line current down to about six volts.

Form the Styrofoam (A) into small balls, First, cut the block into cubes, determining the sizes according to the element each represents:

- H - 1.5 cm on a side
- C - 3 cm      "      "      "
- O - 3 cm      "      "      "
- Si - 4 cm      "      "      "

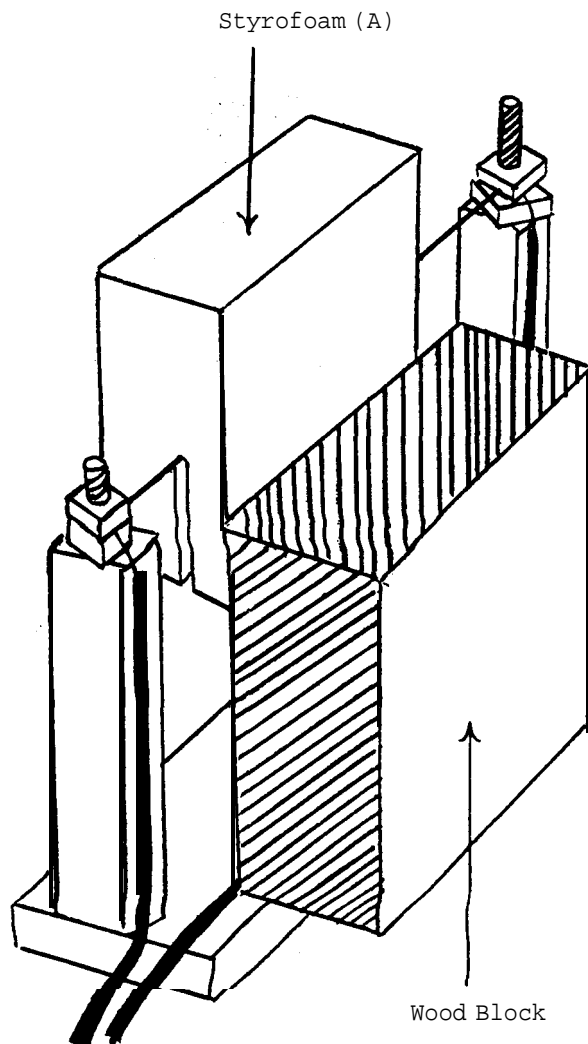

To cut a precise straight line, brace a large wooden block against the base of the bottle cutter, with one edge as far from the taut wire as the width of the desired cut. Push the Styrofoam block (A) down on the hot, taut wire to slice it, holding it against the wooden block which acts as a guide.

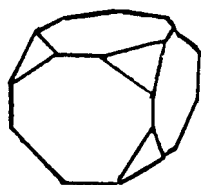

Carefully cut the corners off each cube to approach the shape of a sphere.

Last, shape the trimmed cubes with the fingers more exactly into spheres.

For clarity in the finished models, paint the balls with tempera (poster paint) to which a small amount of dissolved soap has been added. Use the following colors to represent:

- H - white
- C - black
- O - red

(2) Rigid Connectors

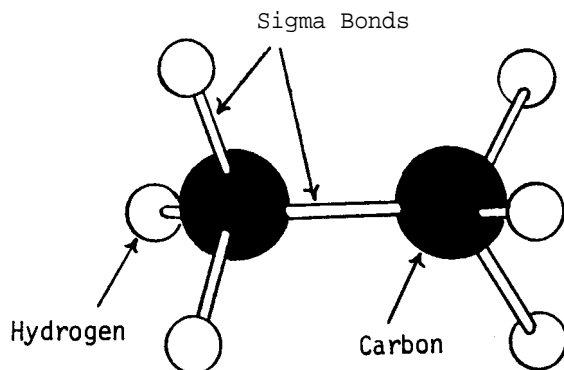

Stick toothpicks (D) into the Styrofoam balls to represent sigma bonds between atoms, as in the ethane molecule ( $C_2H_6$ ) represented here.

(3) Flexible Connectors

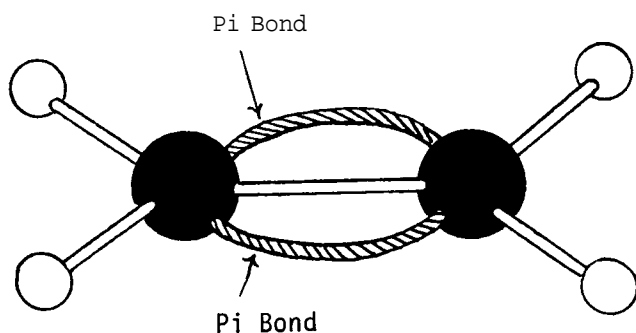

Use pairs of pipe cleaners (E) cut to approximately 5 cm lengths to represent pi bonds between atoms, as in the ethene (ethylene;  $C_2H_4$ ) molecule represented here.

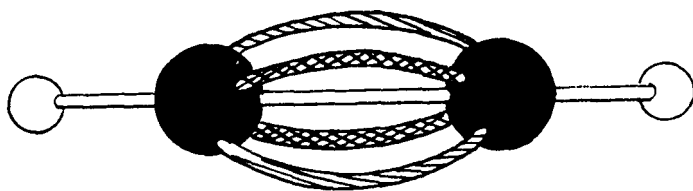

When triple bonds (one sigma and two pi bonds) are to be represented, dye the two pairs of pipe cleaners different colors for clarity. This diagram represents a molecule of ethyne (acetylene;  $C_2H_2$ ).

c. Notes

(i) If commercially manufactured Styrofoam or foam polystyrene balls are easily available, they may be substituted for the hand-made balls described here.

(ii) The scale of approximate sizes of the balls used in these models is based on the atomic radii for stable compounds listed in the Periodic Table of the elements, for example:

Element	Atomic Radius in Angstroms	Approximate Ratio
C	0.77	2
N	0.75	2
O	0.73	2
H	0.32	1

(iii) If Styrofoam or foam polystyrene is not available, modeling clay (plasticine) may be used for the balls and painted appropriate colors. However, once the clay balls are painted, repeated puncturing of them with toothpicks will disfigure them. Thus, it is recommended that they be used only to make permanent demonstration models.

(iv) Pipe cleaners or match sticks may be substituted for the toothpicks if desired.

(v) A kit for teacher use should contain:

- 2 dozen balls representing Carbon
- 2 dozen " " Hydrogen
- 2 dozen " " Oxygen
- 1 dozen " " Halogens
- 1 dozen " " Nitrogen
- 1 dozen " " Sulfur
- several dozen each straight and flexible connectors,

This would provide sufficient materials for constructing demonstration models in the classroom. The same quantities listed above would be adequate for laboratory use for from one to four students.

(vi) The use of molecular models in the study of chemistry can enhance the students' understanding of and ability to predict the various properties and interactions of elements and compounds. These ball and stick models illustrate, roughly, the relative bond angles, sizes and positions of atoms within a molecule in a clear and simple form. They are not, however, scale representations of bond lengths or atomic molecular sizes and shapes. **In** order to demonstrate the mathematical relations of electrons in a given molecule, it will be necessary to employ a different style model, that which is described in the next section.

(vii) The color code \* used in these models is as follows:

Hydrogen - white  
Carbon - black  
Oxygen - red  
Nitrogen - blue  
Sulfur - dark yellow  
Flourine - light green  
Chlorine - dark green  
Bromine - orange  
Iodine - brown  
Phosphorous - violet  
Silicon - light yellow

---

\*From the Portland Project Committee, Teacher Guide, Chemistry of Living Matter, Portland, Oregon: Portland Project Committee, (1971, p 1/.

B. SKELETAL MODELS

B1. Molecular Model Units\*

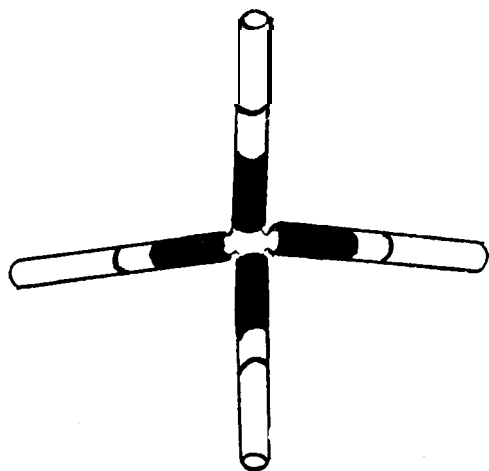

Assembled View

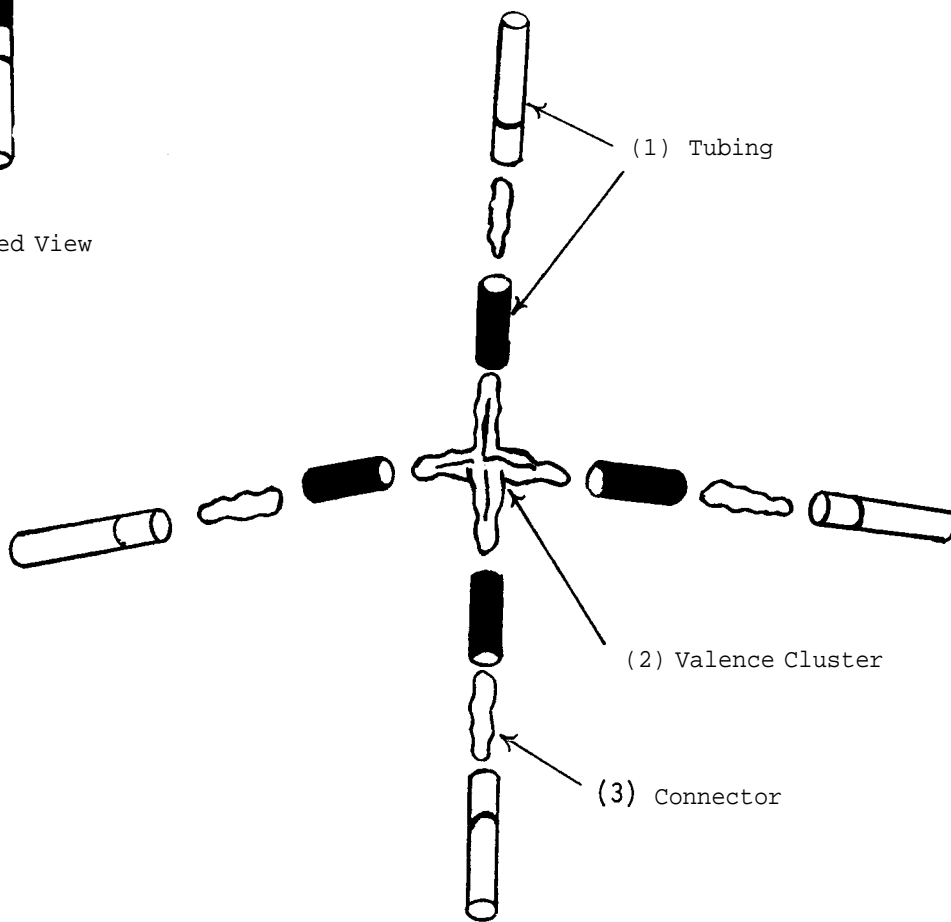

Exploded View

\*Adapted from George C. Brumlik, Edward J. Barrett, and Reuben L. Baumgarten, "Framework Molecular Models," Journal of Chemical Education, XLI (1964), pp 221-223.

a. Materials Required

<u>Components</u>	<u>Qu</u>	<u>Items Required</u>	<u>Dimensions</u>
(1) Tubing	--	Milk Straws (Paper or Plastic) (A)	0.4 cm diameter, approximately 20 cm long
	--	Tempera (Poster) Paints (B)	Black, white, red, yellow, green, blue, orange
(2)	--	Pipe Cleaners (C)	--
(3) Connector	--	Pipe Cleaners (D)	--
	--	Finishing Nails (E)	Approximately 0.1 cm diameter, 1.5 cm long
	--	Soft Iron Wire (F)	Approximately 0.05 cm diameter

b. Construction

(1) Tubing

Mix a small amount of liquid or dissolved soap with the tempera paints (B) to reduce their surface tension. Using this mixture, paint several milk straws (A) according to the atom they are to represent:

- Carbon - black
- Hydrogen - white
- Oxygen - red
- Nitrogen - blue
- Sulfur - dark yellow
- Bromine - orange
- [Consult Note (ii) for additional colors.]

Cut the straws into various lengths depending upon the scale used and bond represented.

Bend a pipe cleaner (C) into the shape desired, and glue the joint in the middle. When the glue has dried, adjust the angles of the arms of the connector to suitable angles.

(2) Valence Cluster

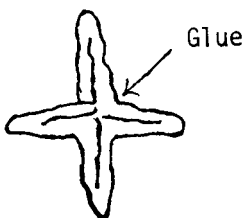
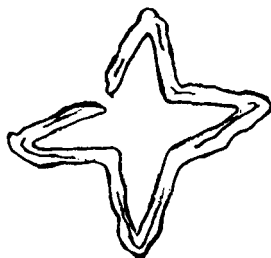

Bend



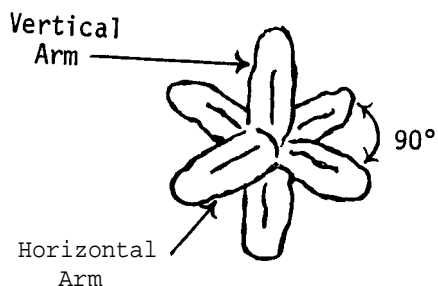
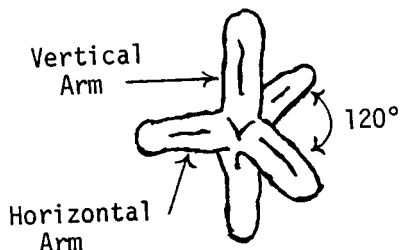
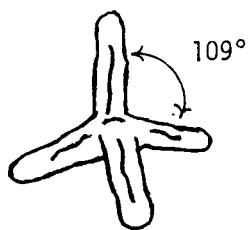

Make tetrahedral (4 arms) shapes with the angles of the arms at about 109'.

Make trigonal bipyramid (5 arms) shapes. Arrange the angles between the three horizontal arms to 120'. Adjust the two vertical arms at right angles to the horizontal arms.

Construct octahedrons (8-pointed), Adjust the angles between the four horizontal arms to 90'. Arrange the two vertical arms at right angles to the horizontal arms,

(3) Connectors

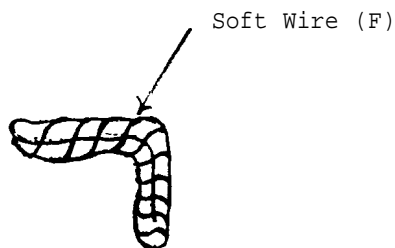
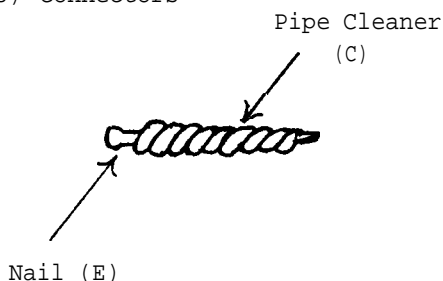

Construct straight connectors to represent bonds between atoms by wrapping a pipe cleaner (C) around a nail (E). Vary the length of pipe cleaner used according to the tightness desired.

To make angular connectors to be used to complete various structures, bend a pipe cleaner (C) in half. Then wrap soft wire (F) around the pipe cleaner and bend the assembly to a 90' angle.

c. Notes

(i) These units can be used to build models of almost any molecule, The valence clusters represent atomic nuclei, the intersection of the arms representing the center of the atom. The tetrahedral (4-armed) valence cluster depicts bond angles

of approximately 109°, for sp<sup>3</sup> hybridized orbitals or atoms with eight electrons in their valence shell. The five-armed valence cluster can depict sp<sup>2</sup> hybridization, with 120° bond angles, for atoms engaged in (pi) bonds, as well as d sp<sup>3</sup> hybridization, with 90° and 120° bond angles for atoms with ten atoms in their valence shell. The six-armed valence cluster can represent sp hybridization with bond angles near 180°, or d<sup>2</sup>sp<sup>3</sup> hybridization for atoms with twelve electrons in their valence shell. The straight connector depicts σ (sigma) bonds between like or unlike atoms.

Electrons, whether bonded or unshared, are represented by the straws, color coded and cut to scale.

The straws in a completed molecular model represent covalent radii of bonding atoms, and van der Waals radii in the non-bond direction.

(ii) Below are charts\* to guide the coloring and cutting of straws to represent covalent radii or van der Waals radii. Any convenient scale may be used to simulate the Ångstrom unit (Å) measurements of these forces. For example, a scale of 10 cm/Å produces large models ideal for lecture demonstrations, while a scale of 2 cm/Å yields smaller models suitable for student use.

Bond	Atomic Covalent Radii (Å)	Length of Straw in cm (Scale: 10 cm/Å)	Length of Straw in cm (Scale: 2 cm/Å)	Color of Straw
C - single	0.77	7.7	1.5	black
C - double	0.67	6.7	1.3	
C - triple	0.60	6.0	1.2	
O - single	0.74	7.4	1.5	red
O - double	0.62	6.2	1.2	
O - triple	0.55	5.5	1.1	
N - single	0.74	7.4	1.5	blue
N - double	0.62	6.2	1.2	
N - triple	0.55	5.5	1.1	

\*Adapted from the Portland Project Committee, Teacher Guide, Chemistry of Living Matter, (Portland, Oregon: Portland Project Committee, 1971), pp 8-18.

Bond (single)	Atomic Covalent Radii (Å)	Length of Straw in cm (Scale: 10 cm/Å)	Length of Straw in cm (Scale: 2 cm/Å)	Color of Straw
H	0.30	3.0	0.6	white
F	0.64	6.4	1.3	light green
Si	1.17	11.7	2.3	light yellow
P	1.10	11.0	2.2	violet
S	1.04	10.4	2.1	dark yellow
Cl	1.00	10.0	2.0	dark green
Br	1.14	11.4	2.3	orange
I	1.33	13.3	2.7	brown

Atom	Van der Waals Radii (Å)	Length of Straw in cm (Scale: 10 cm/Å)	Length of Straw in cm (Scale: 2 cm/Å)	Color of Straw
H	1.2	12.0	2.4	white
O	1.40	14.0	2.8	red
F	1.35	13.5	2.7	light green
S	1.85	18.5	3.7	dark yellow
Cl	1.80	18.0	3.6	dark green
Br	1.95	19.5	3.9	orange
I	2.15	21.5	4.3	brown
N	1.5	15.0	3.0	blue
P	1.9	19.0	3.8	violet

B2. Single Bond Structures\*

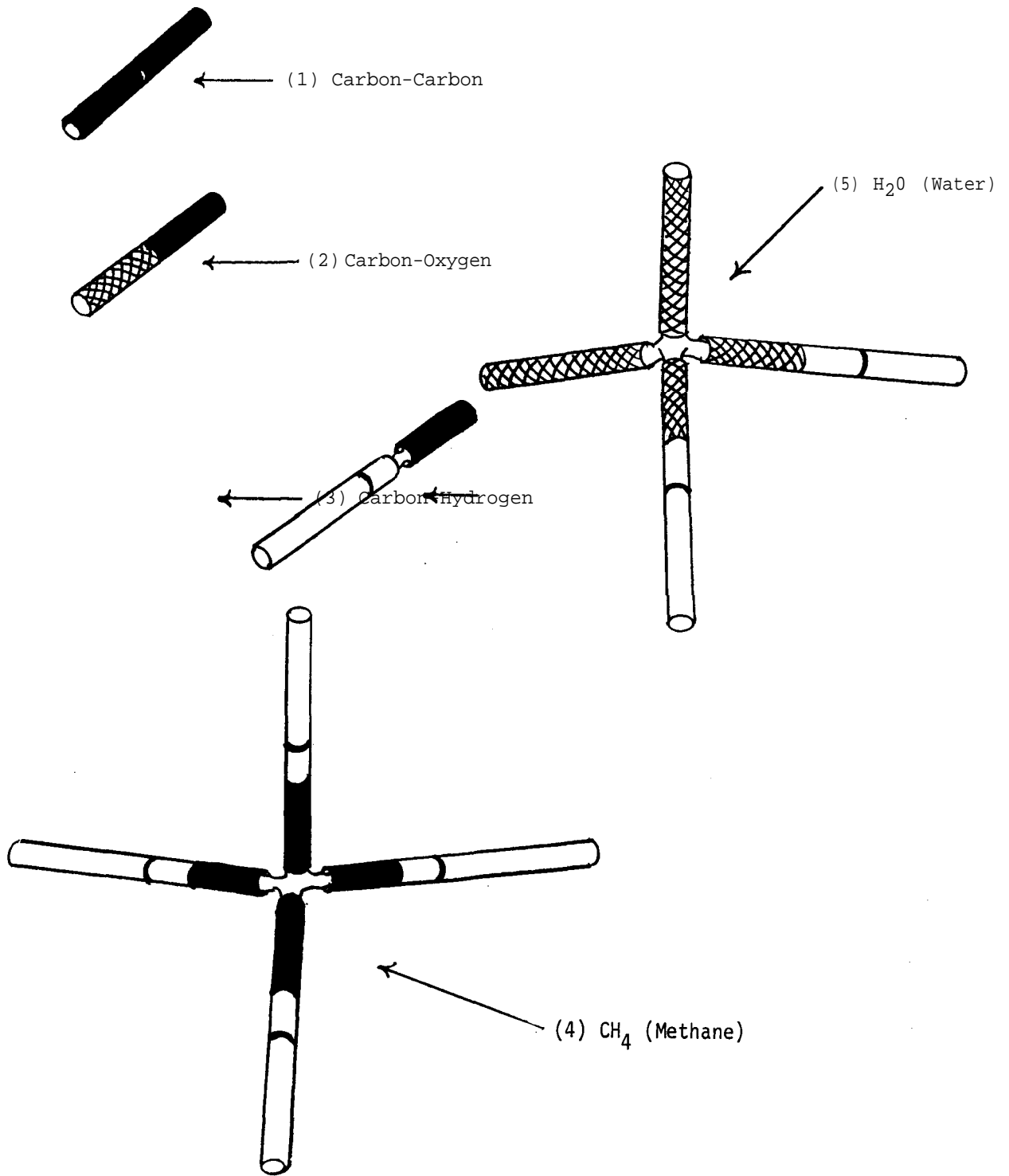

\*Adapted from the Portland Project Committee, Teacher Guide, Chemistry of Living Matter, (Portland, Oregon: Portland Project Committee, 19/1), pp 19-28.

a. Materials Required

<u>Components</u>	<u>Qu</u>	<u>Iterns Required</u>	<u>Dimensions</u>
(1) Carbon-Carbon	1	Straight Connector (A)	X/B1
	2	Black Straws (B)	1.5 cm
(2) Carbon-Oxygen	1	Straight Connector (C)	X/B1
	1	Black Straw (D)	1.5 cm
	1	Red Straw (E)	1.5 cm
(3) Carbon-Hydrogen	1	Straight Connector (F)	X/B1
	1	Black Straw (G)	1.5 cm
	1	White Straw (H)	3.0 cm
(4) CH <sub>4</sub> (Methane)	1	4-armed Valence Cluster (I)	X/B1
	4	Carbon-Hydrogen Bonds (F,G,H)	4.5 cm [see (3) above]
(5) H <sub>2</sub> O (Water)	1	4-armed Valence Cluster (J)	X/B1
	2	Red Straws (K)	i 5 cm
	2	Red Straws (L)	2.8 cm
	2	White Straws (M)	3.0 cm
	2	Straight Connectors (N)	X/B1

b. Construction

(1) Carbon-Carbon

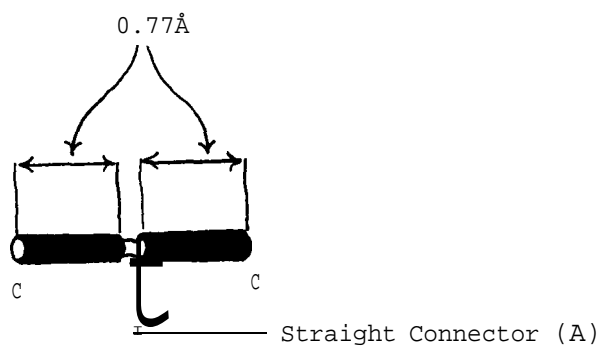

To represent this single covalent bond between like atoms, cut two black straws (B) to a scale representation of the single bond covalent radius of carbon (X/BI), Note (ii). For example, cut the straws to 1.5 cm for a scale of 2 cm/Å. Join these two straws with a straight connector (A).

(2) Carbon-Oxygen

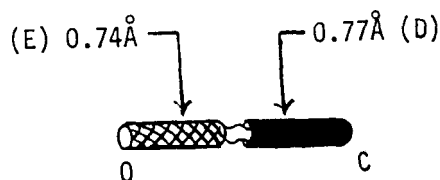

To construct this model of a single covalent bond between unlike atoms, cut one black straw (D) to represent the single bond covalent radius for carbon (1.5 cm, for example) and a red straw to represent the single bond covalent radius for oxygen (E) (1.5 cm). Connect

(3) Carbon-Hydrogen

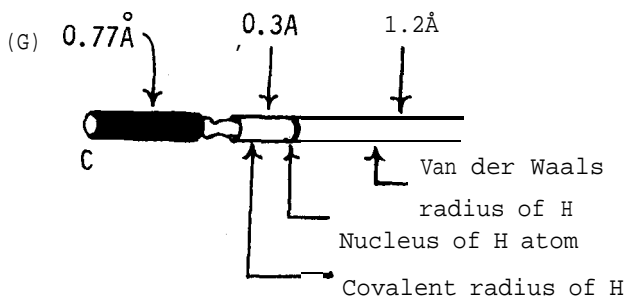

(4) CH<sub>4</sub> (Methane)

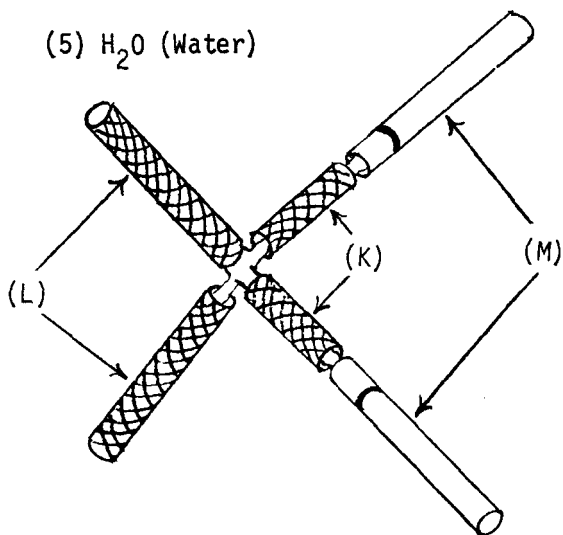

these two straws with a straight connector (C).

Construct the carbon-hydrogen bond to include a representation of the van der Waals radius for hydrogen. Cut one black straw (G) to indicate the single bond covalent radius for carbon. Cut one white straw (H) to show the covalent radius of H (0.6 cm) plus the van der Waals radius of H (2.4 cm). Draw a line around the white straw at the intersection of these two values to indicate the position of the hydrogen nucleus, then join the black and white straws with a straight connector (F).

Construct four carbon-hydrogen bonds (F,G,H) as described above. Join them all together at the carbon end by sliding each onto an arm of the four-armed valence cluster (I) and pushing all the straws together so that the connectors do not show.

Cut two red straws (L) to represent the van der Waals radius of O (2.8 cm). These will represent two unshared electron pairs, Cut two red straws (K) to indicate the single bond covalent radius of O (1.5 cm). Use a straight connector (N) to join each of these with a white straw (M) representing the covalent and

van der Waals radii of H (3.0 cm).  
Connect the two red straws and  
two O - H bonds with a four-armed  
connector (J) as illustrated.

C.Notes

(i) Single covalent bonds between like atoms, such as the carbon-carbon bond,



may also be represented by one  
straw, appropriately colored,  
cut to twice the covalent radius.  
Thus, the carbon-carbon bond

would be represented by one black straw, 3 cm long.

(ii) Unlike the space-filling models of X/Al, these models do not show molecular  
shape. The shape of the constituent atoms within a molecule must be imagined;  
the scale and orientation of the parts of the model show bond lengths, bond angles,  
and bond thicknesses in reasonably accurate scale.

(iii) These skeletal molecular models are based on atomic orbital geometry, which  
deals with the behavior of electrons in paths, or orbitals, in the space around  
the nucleus of an atom. For a complete discussion of electrons, nuclei, and  
orbitals, consult recent chemistry texts, such as Chemical Bond Approach Project,  
Chemical Systems, (Webster Division McGraw-Hill Book Company, 1964), Chapter 10.

B3. Double Bond Structures\*

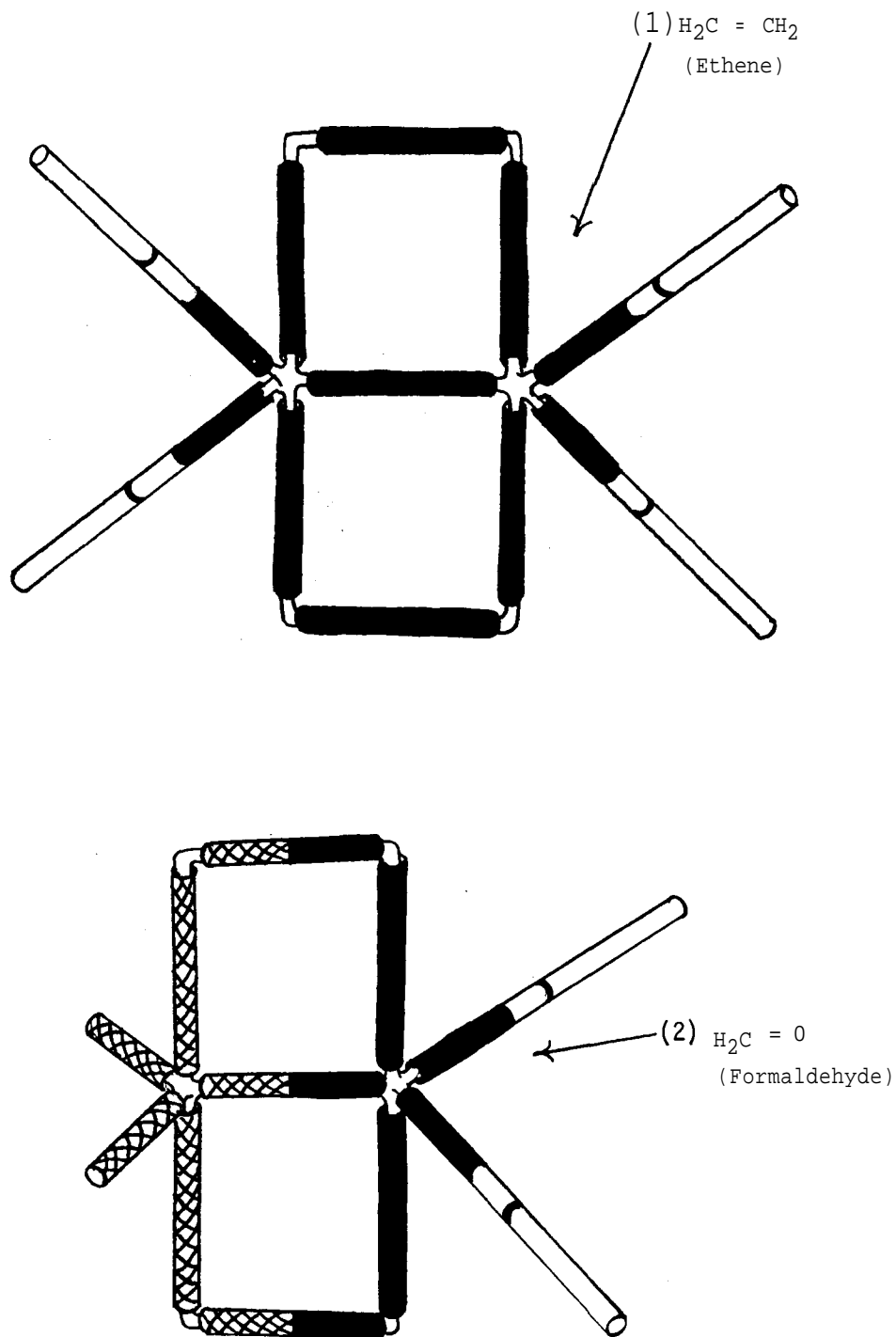

Adapted from the Portland Project Committee, Teacher Guide, Chemistry of Living Matter, (Portland, Oregon: Portland Project Committee, 1971) pp 28-36.



(3)  $C_6H_6$   
(Benzene)

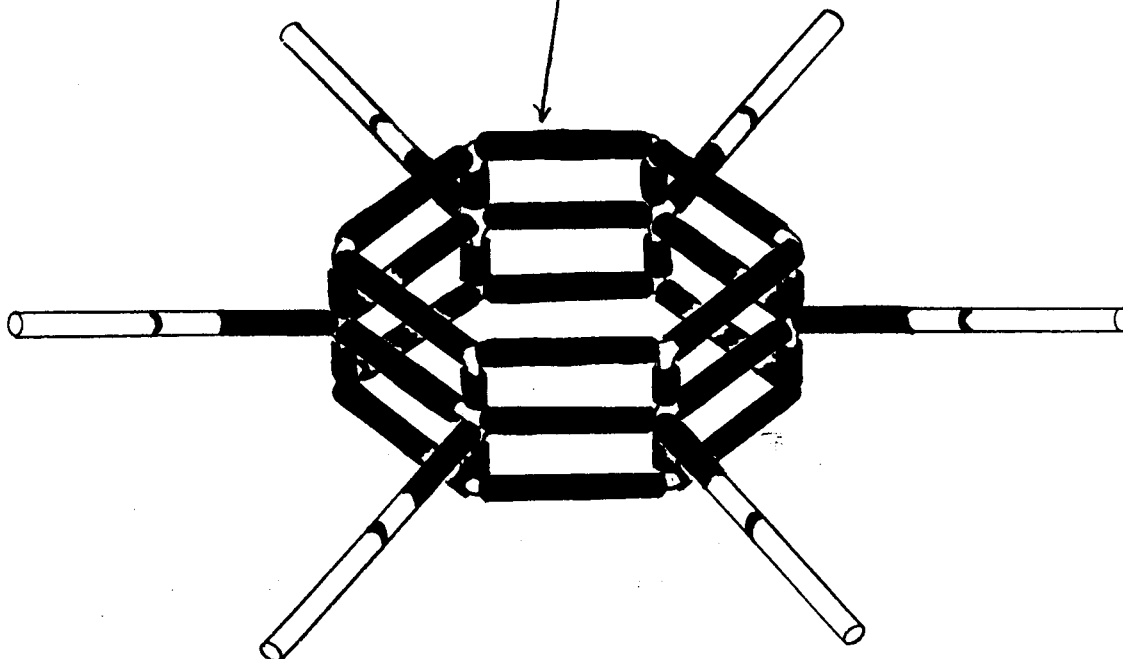

(4)  $H_2C = C = CH_2$   
(Allene)

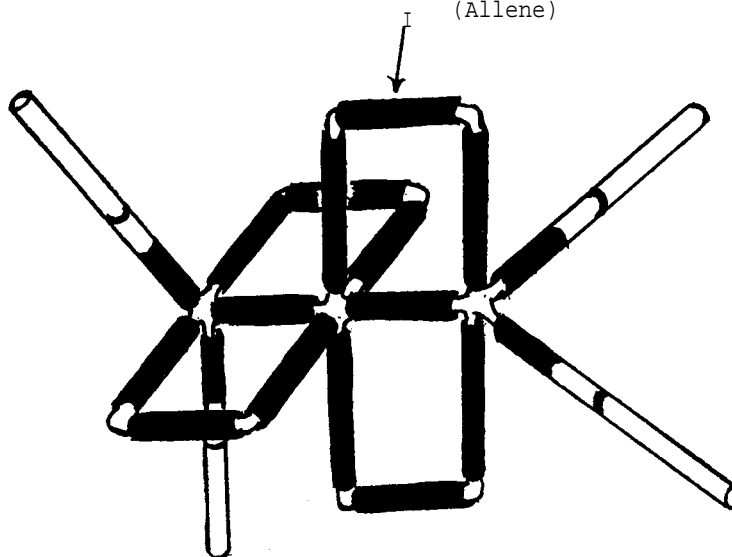

a. Materials Required

<u>Components</u>	<u>Qu</u>	<u>Items Required</u>	<u>Dimensions</u>
(1) $H_2C=CH_2$ (Ethene)	2	5-armed Valence Clusters (A)	X/B1
	4	C-H Bonds (B)	4.5 cm
	3	Black Straws (C)	2.6 cm
	4	Black Straws (D)	3.0 cm
	4	Angular Connectors (E)	X/B1
(2) $H_2C=O$ (Formaldehyde)	2	5-armed Valence Clusters (F)	X/B1
	4	Angular Connectors (G)	X/B1
	2	C-H Bonds (H)	4.5 cm
	3	Red Straws (I)	1.2 cm
	3	Black Straws (J)	1.3 cm
	2	Red Straws (K)	3.0 cm
	2	Black Straws (L)	3.0 cm
	2	Red Straws (M)	1.5 cm
	3	Straight Connectors (N)	X/B1
(3) $C_6H_6$ (Benzene)	18	5-armed Valence Clusters (O)	X/B1
	6	C-H Bonds (P)	4.5 cm
	18	Black Straws (Q)	2.6 cm
	12	Black Straws (R)	3.0 cm
(4) $H_2C=C=CH_2$ (Allene)	2	5-armed Valence Clusters (S)	X/B1
	1	6-armed Valence Clusters (T)	X/B1
	4	C-H Bonds (U)	4.5 cm
	6	Black Straws (V)	2.6 cm
	8	Black Straws (W)	3.0 cm
	8	Angular Connectors (X)	X/B1

b. Construction

(1)  $H_2C=CH_2$  (Ethene)

First construct four C-H bonds (B) (X/B2). Then complete the  $H_2C=CH_2$  molecule as shown. Use three 2.6 cm black straws (C) to represent double bond formation between like atoms. The central black straw (C)

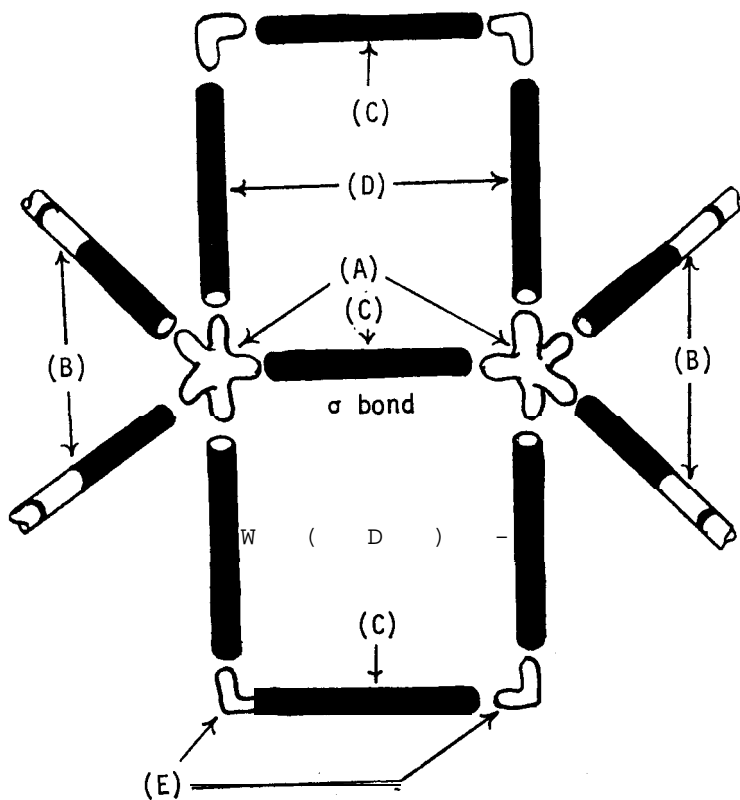

represents the  $\sigma$  bond. The two outside sections of black straws (C) represent the two arms of the bond, the thickness of which is shown by the four 3.0 cm black straws (D). Their length represents the single bond covalent radius of carbon.

(2)  $H_2C=O$  (Formaldehyde)

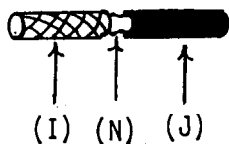

Construct this model showing double bond formation between like atoms. First, construct three  $C=O$  bonds representing the double bond radii C (J) and O (I), as shown. Make two C-H bonds (H) ( $X/B2$ ).

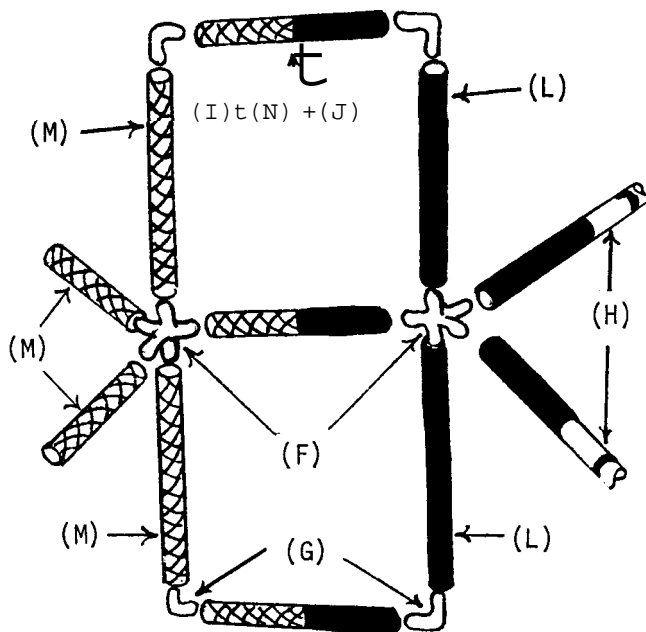

Use the 5-armed valence clusters (F) and angular connectors (G) to join the straws. Indicate the thickness of the  $\pi$  bond by red straws on the oxygen side, black straws on the carbon side.

(3)  $C_6H_6$  (Benzene)

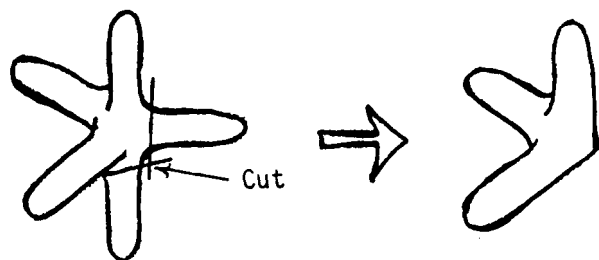

Cut off and discard one horizontal and one vertical arm from each of twelve 5-armed valence clusters (O) to form 3-cornered clusters.

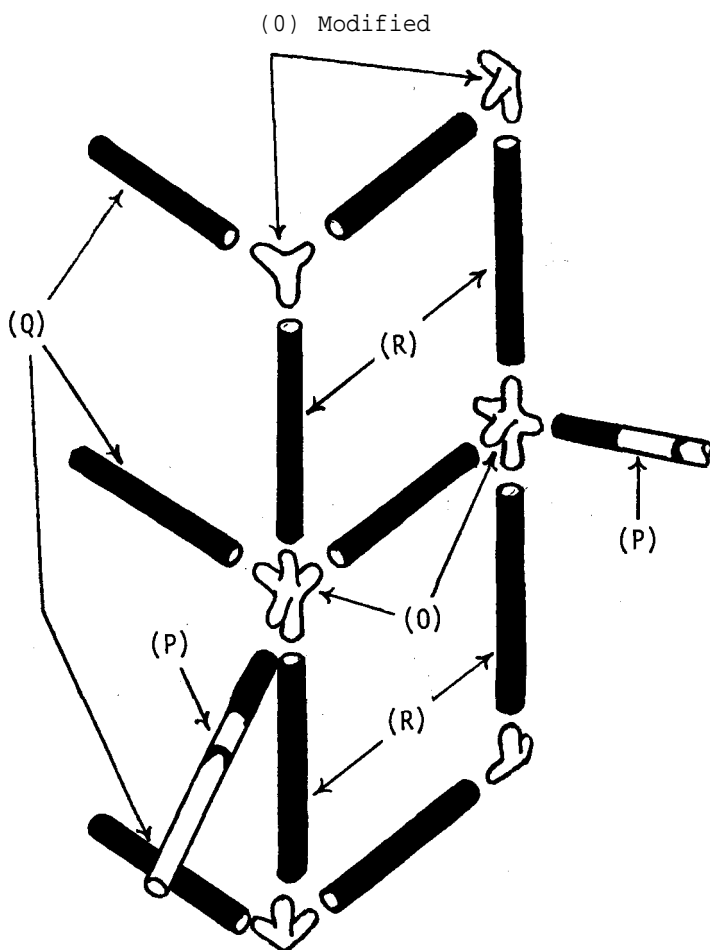

One corner, exploded view

Make six C-H bonds (X/B2) (P). Construct the three layered model as shown. Use the twelve 3.0 cm black straws (R) to represent the thickness of the bonds (twice the single covalent radius of carbon). Use the eighteen 2.6 cm black straws (Q) to represent the bond lengths (twice the double covalent bond radius of carbon). The shared-bond aspect of the ring structure often pictured:

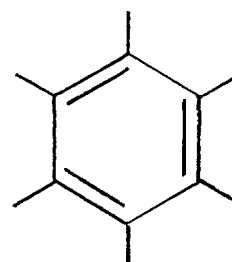

is represented in the model by the three-layered structure.

(4)  $H_2C=CH_2$  (Allene)

Construct four C-H bonds (U). Use one 6-armed valence cluster (T), as well as two 5-armed clusters (S), to connect the the components of the  $H_2C-C-CH_2$  (allene) molecule.

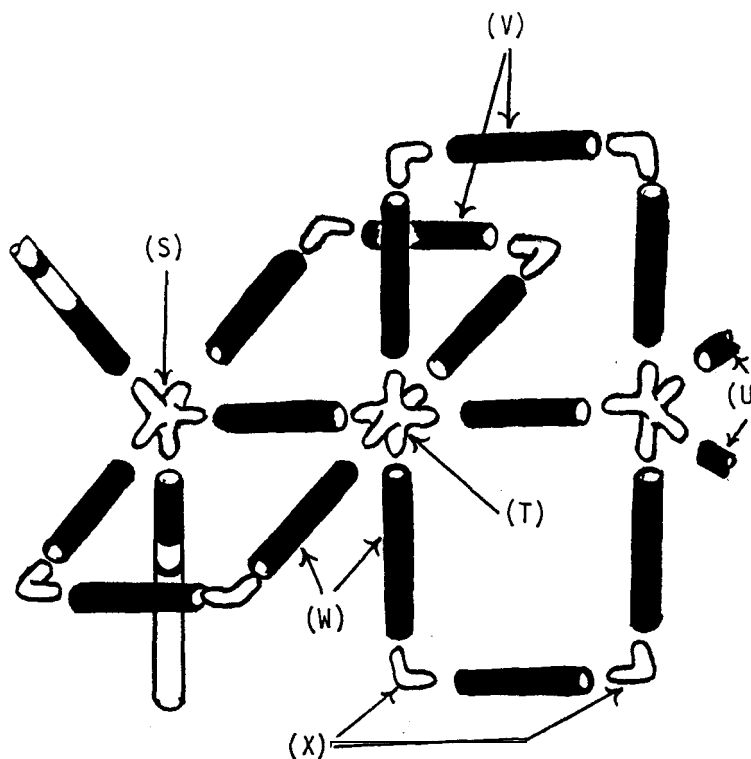

Place the 6-armed cluster (T) as shown to indicate that the middle carbon atom is bonded to each of the side carbons.

C. Notes

(i) These four examples of double bond models illustrate some of the complex double bond forms that can be built. By applying the principles thus illustrated, it should be possible to construct almost any simple or complex double bonded molecule.

(ii) because the forces holding two nuclei together in a double bond are greater than those in a single bond, the nuclei are closer together, Thus, the straws representing the C=C or C=R covalent distance are shorter than those representing the C-C or C-R distance.

(iii) In the  $H_2O=O$  (formaldehyde) molecule, the slightly longer tubing representing the bond thickness at the carbon atom than at the oxygen atom indicates a certain strain on the double bond. The covalent radius of oxygen is used to model the unbonded electrons, rather than the van der Waals radius as in the model of water, because the C=O bond "pulls" or distorts the oxygen electron cloud. C=N bonds may be constructed just as C=C and C=O bonds; blue tubing represents N.

B4. Triple Bond Structure\*

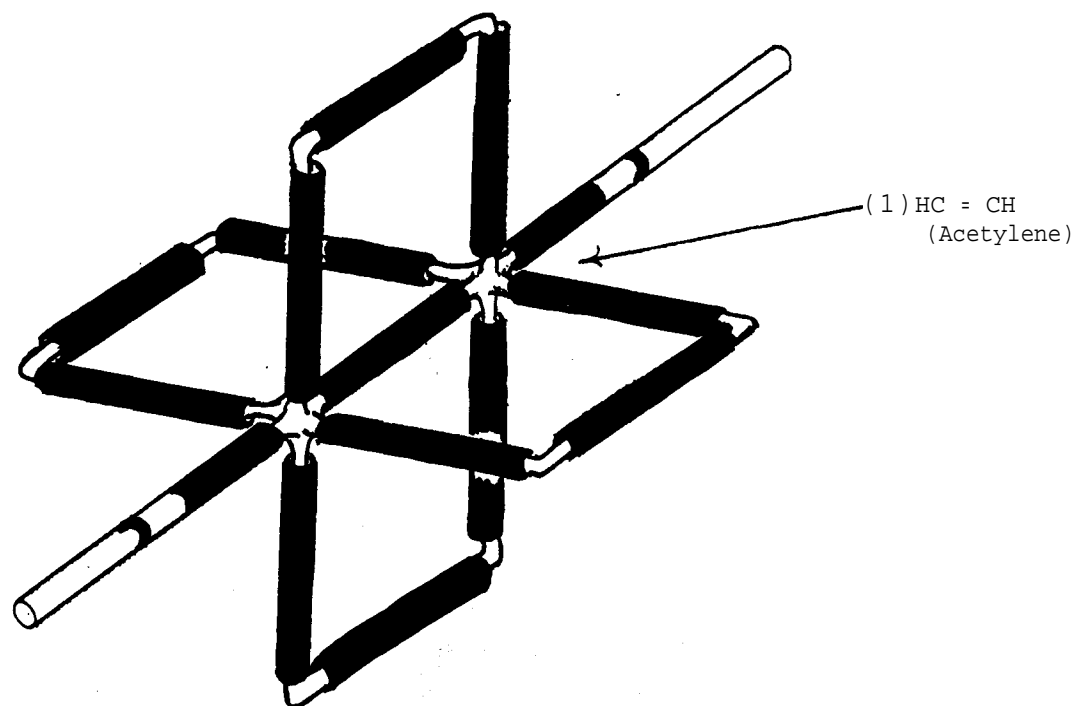

a. Materials Required

<u>Components</u>	<u>Qu</u>	<u>Items Required</u>	<u>Dimensions</u>
(1) HC=CH (Acetylene)	2	6-armed Valence Clusters (A)	X/B1
	8	Angular Connectors (B)	X/B1
	2	C-H Bonds (C)	4.5 cm
	5	Black Straws (D)	2.4 cm
	8	Black Straws (E)	3.0 cm

\*Adapted from the Portland Project Committee, Teacher Guide, Chemistry of Living Matter, (Portland, Oregon: Portland Project Committee, 1971), pp 36-3/.

b. Construction

(1) HC=CH (Acetylene)

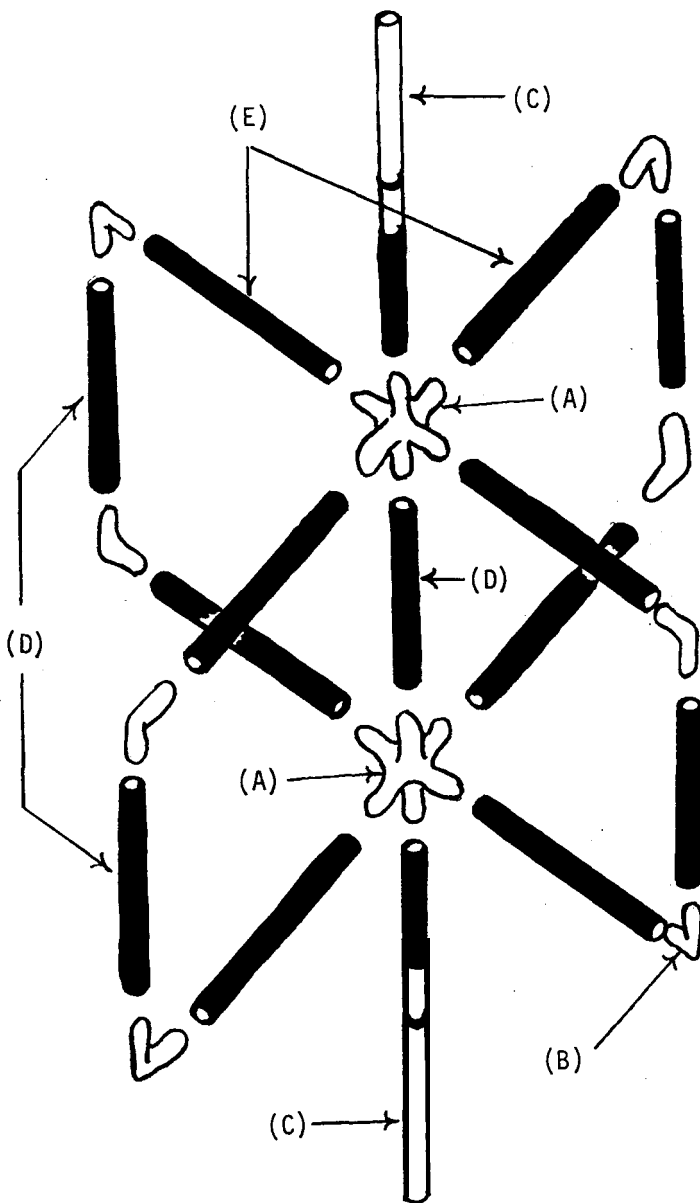

First make two C-H bonds (C) (X/B2) Then use two 6-armed valence clusters (A) and eight angular connectors (B) to connect the parts of the HC=CH (acetylene) molecule as shown. The 2.4 cm black straws (D) indicate the length of the triple bond, and are cut to represent twice the triple covalent bond radius for carbon. Bond thickness is indicated by the 3.0 cm straws (E) or twice the single bond radius for carbon.

c. Notes

(i) Because the forces holding two nuclei together in a triple bond are stronger even than those of a double bond, the nuclei are closer together. Thus, the straws representing the C-H covalent distance are shorter than those representing the C-C distances. Nuclei involved in sp hybridization with triple bond formation are represented in the model by the 6-armed sp valence cluster.

(ii) In the HC=H (acetylene) model, the central carbon-carbon bond represents the  $\sigma$  bond. The four outside sections of black straws represent two double-armed bonds.

B5. Geometric Structures\*

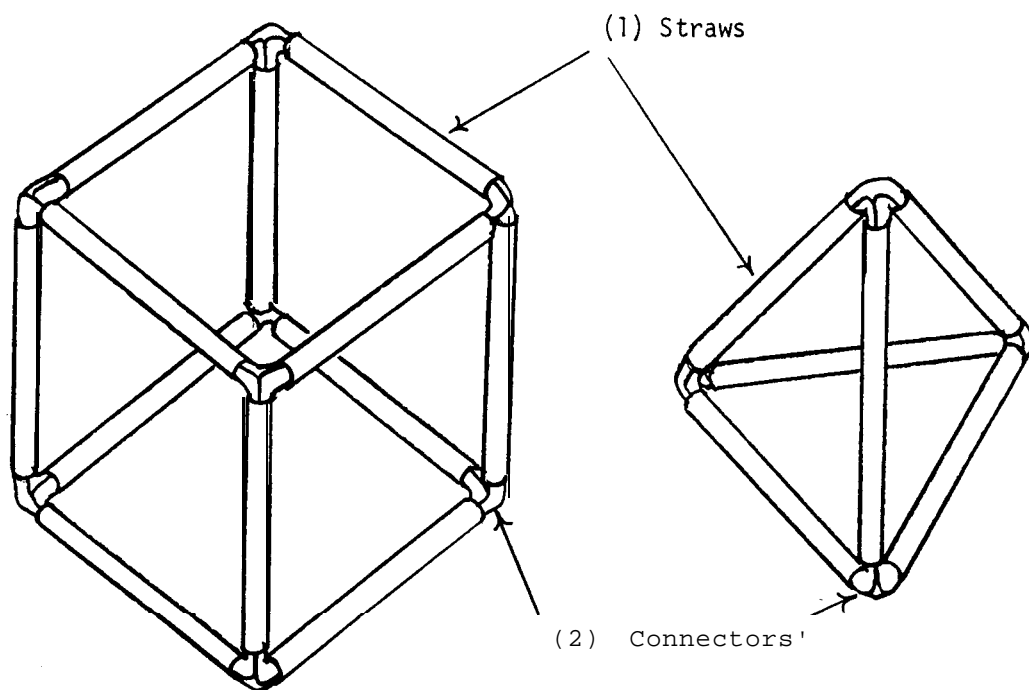

a. Materials Required

<u>Components</u>	<u>Qu</u>	<u>Items Required</u>	<u>Dimensions</u>
(1) Straws	--	Paper or Plastic Milk Straws (A)	Approximately 0.4 cm diameter
	--	Pipe Cleaners (B)	Approximately 3 cm long

b. Construction

(1) Straws

Cut the straws (A) to any convenient length, 5 cm, for example. Paint the straws, if desired, with poster (tempera) paints to which a small amount of dissolved soap has been added.

\*Adapted from D.C. Hobson and C. V. Platts, "Milk-Straw Molecular Models," School Science Review, CLXII(1966)pp 694-701.



(2) Connectors



Bend the cut pipe cleaners (B) to form right angles.

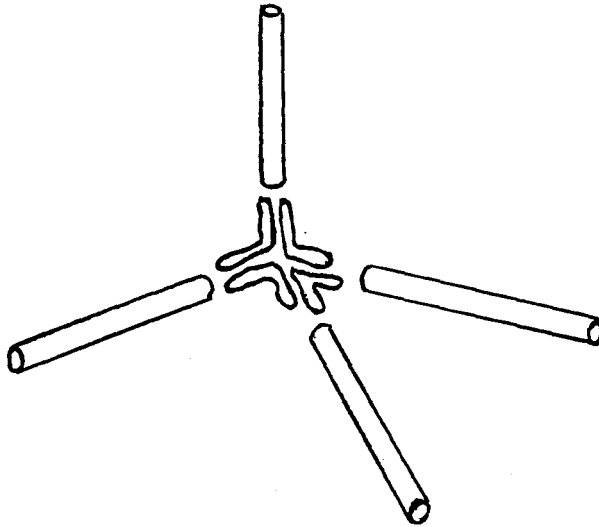

Insert the pipe cleaners (B) into the straws (A), as shown, to form secure connections.

C.Notes

(i) By selecting appropriate numbers of straws and connectors, a variety of geometric forms may be built.

C. CRYSTAL STRUCTURE MODELS

Cl. Crystalline Packing Models\*

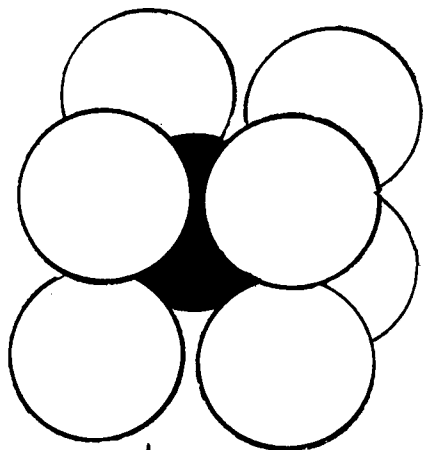

(1) Body-Centered  
-Cubic Unit Cell

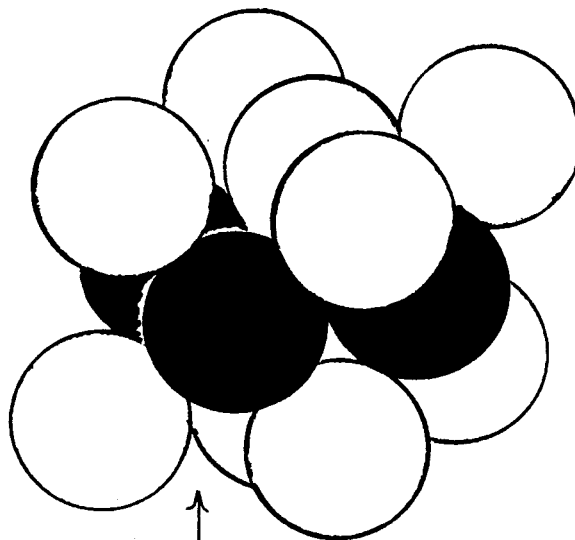

(2) Face-Centered  
Cubic Unit Cell

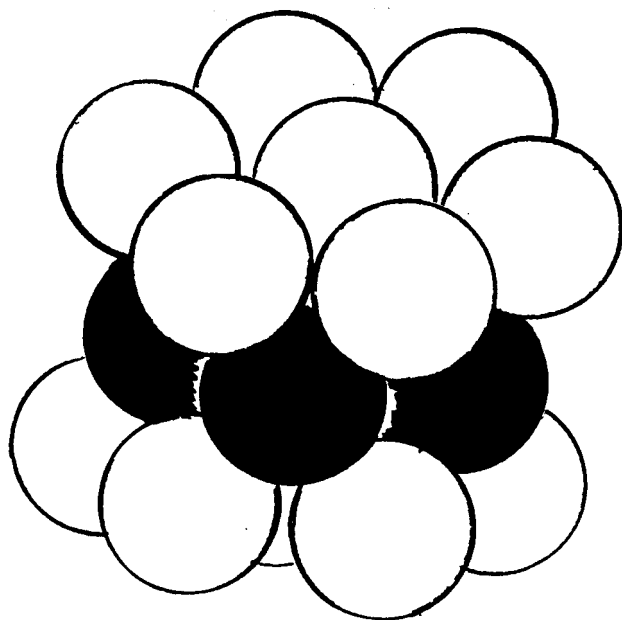

(3) Closely-Packed  
Hexagonal Unit Cell

\*Adapted from J. W. Coakham, W. Evans, and H. Nugent, "Introducing Crystal Structures," School Science Review, CLXXIV (1969), pp 61-71.

a. Materials Required

<u>Components</u>	<u>Qu</u>	<u>Items Required</u>	<u>Dimensions</u>
(1) Body-Centered Cubic Unit Cell	9	Styrofoam or Foam Polystyrene Spheres (A)	Approximately 4 cm diameter
(2) Face-Centered Cubic Unit Cell	14	Styrofoam or Foam Polystyrene Spheres (B)	Approximately 4 cm diameter
(3) Closely-Packed Hexagonal Unit Cell	17	Styrofoam or Foam Polystyrene Spheres (C)	Approximately 4 cm diameter

b. Construction

(1) Body-Centered Cubic Unit Cell

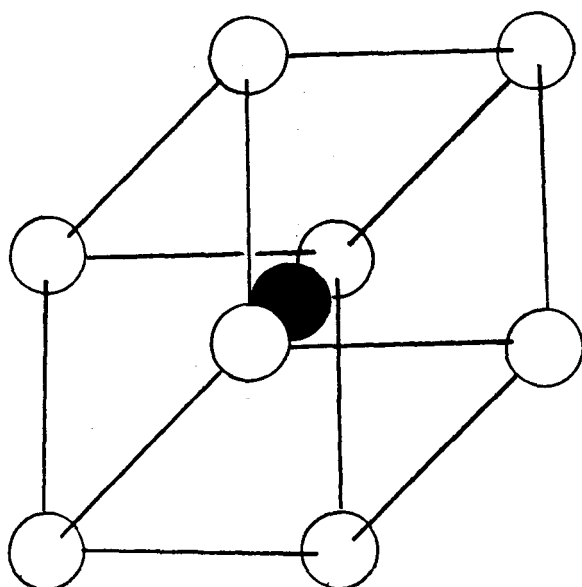

Make the spheres (A) from Styrofoam or foam polystyrene (X/Bl) or purchase spheres from a commercial source. Use the nine spheres to represent the atoms of the crystal according to the "exploded" diagram. Place four spheres in the top and bottom layers, and one in the middle. Use toothpicks, pipe cleaners, match sticks, or cement to hold the spheres together,

(2) Face-Centered Cubic Unit Cell

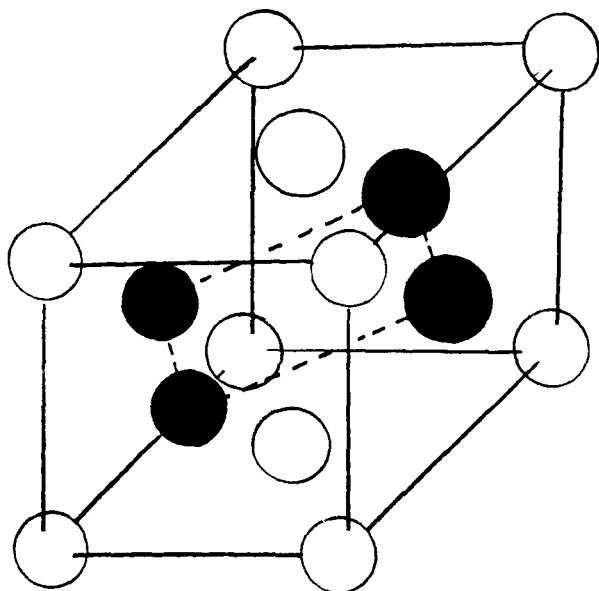

Use this exploded diagram as a guide for building the face-centered cubic unit cell from 14 spheres (B). Place five spheres in both top and bottom layers, and four spheres in the middle layer.

(3) Closely-Packed Hexagonal Unit Cell

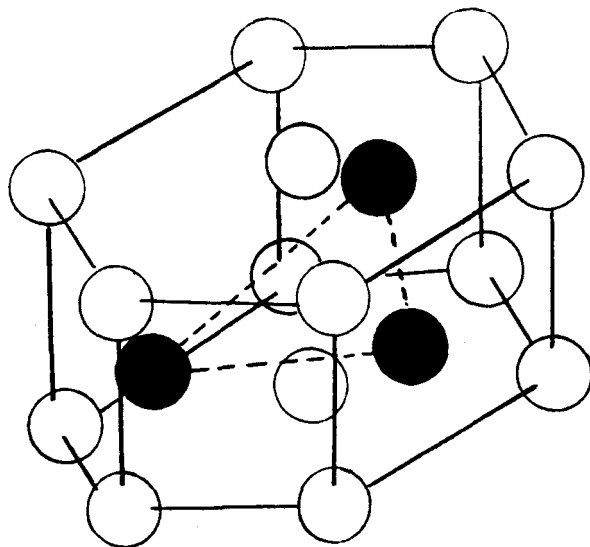

Use seventeen spheres (C) as illustrated to build the closely-packed hexagonal unit cell. Place seven spheres in the top and bottom layers, with three in the middle layer.

C. Notes

(i) The models described demonstrate three-dimensional patterns found in crystals of metals, where the atoms are all of one size and the bonding forces are equal in all directions. As with previous models, the use of molecular models aids the student in both understanding the structure and predicting the characteristics of the substances studied.

(ii) If it is necessary to construct crystal models showing different ion sizes, smaller or larger Styrofoam spheres may be used. For example, ionic crystal models

may be constructed using spheres 2 cm in diameter for anions, and 0.2 cm diameter for cations,

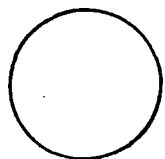

Anion  
2 cm



Cation  
0.2 cm

(iii) These models may be also used to demonstrate such aspects of crystal structures as coordination number, most closely-packed planes and Miller Indices,

(iv) For further discussions on the application of these models to the study of the molecular structure of crystals, consult J. W. Coakham, W. Evans, and H. Nugent, "Some Aspects of Crystal Structure, Part I," School Science Review, CLXXIX, pp 339-350.



plus the few larger marbles (F),  
to represent the molecules in  
a gas.

c. Notes

(i) To demonstrate, two-dimensionally, the kinetic activity of molecules in matter, place all the marbles in the tray. Rest one end of the tray on the dowel

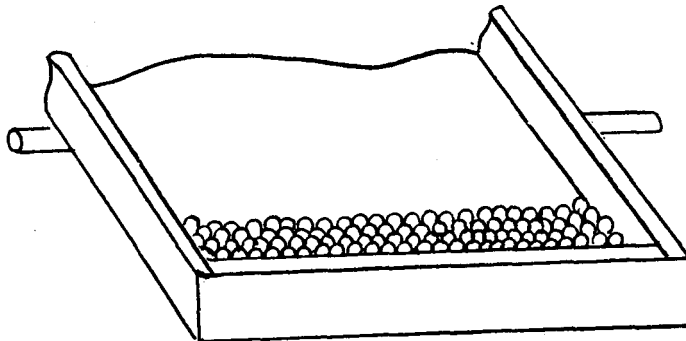

so that the marbles all roll to the opposite end, packing into a regular structure with each marble, or "molecule" touching six neighbors.

(ii) When the tray is at rest, none of the "molecules" move, representing the theoretical condition of matter at absolute zero. When the tray is gently agitated back and forth, the "molecules" **begin** to vibrate and to show "thermal expansion". They occupy a larger volume, but generally retain the same relative position. Occasionally a few molecules jump clear of the surface, representing the slight vapor pressure of a solid.

(iii) As the tray is agitated still harder, with greater amplitude, the "solid" "melts" with the "increase in temperature" (increase in kinetic energy). The

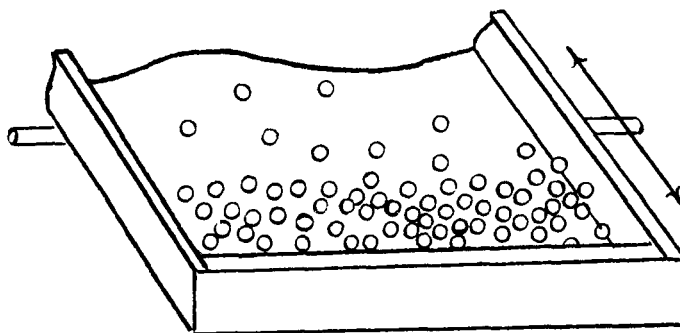

molecules slip out of place, the volume increases, and more molecules jump away from the surface.

By slowing down the rate and amplitude of vibration, the "liquid" can be converted back to a "solid". Slowing the vibration gently represents gradual cooling and results in a regular structure. If however, the vibration suddenly ceases, rapid cooling is demonstrated. The resulting "solid" shows an irregular structure with many imperfections.

(iv) For a demonstration of a "gas", most of the molecules are removed, and the tray is agitated more rapidly than for the "solid" or "liquid". All the

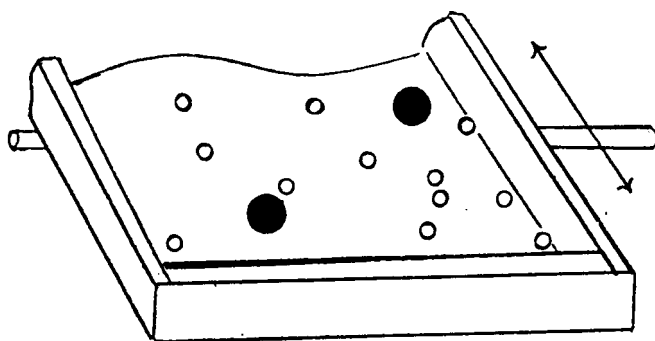

molecules move rapidly and randomly about, traveling large distances before colliding with one another. A few larger marbles, added to the "gas", move with small, irregular, jerky motions, representing the Brownian motion of dust or smoke particles in air.

(v) If a clean glass tray and overhead projector is available, the model may be projected on a screen for a large class to see. The "molecules" show on the screen as shadows.