

I. BALANCES

The balances presented have been divided into three categories:

A. ELEMENTARY BALANCES

These are relatively crude, but extremely easy to make, even for elementary students, and serve as an excellent introduction to an understanding of balances.

B. EXPERIMENTAL BALANCES

These are somewhat more exact and are useful for undertaking investigations into the properties of balance.

C. FUNCTIONAL BALANCES

These are relatively sophisticated and designed primarily for functional usage.

A. ELEMENTARY BALANCES

Al. Spring Lever Balance

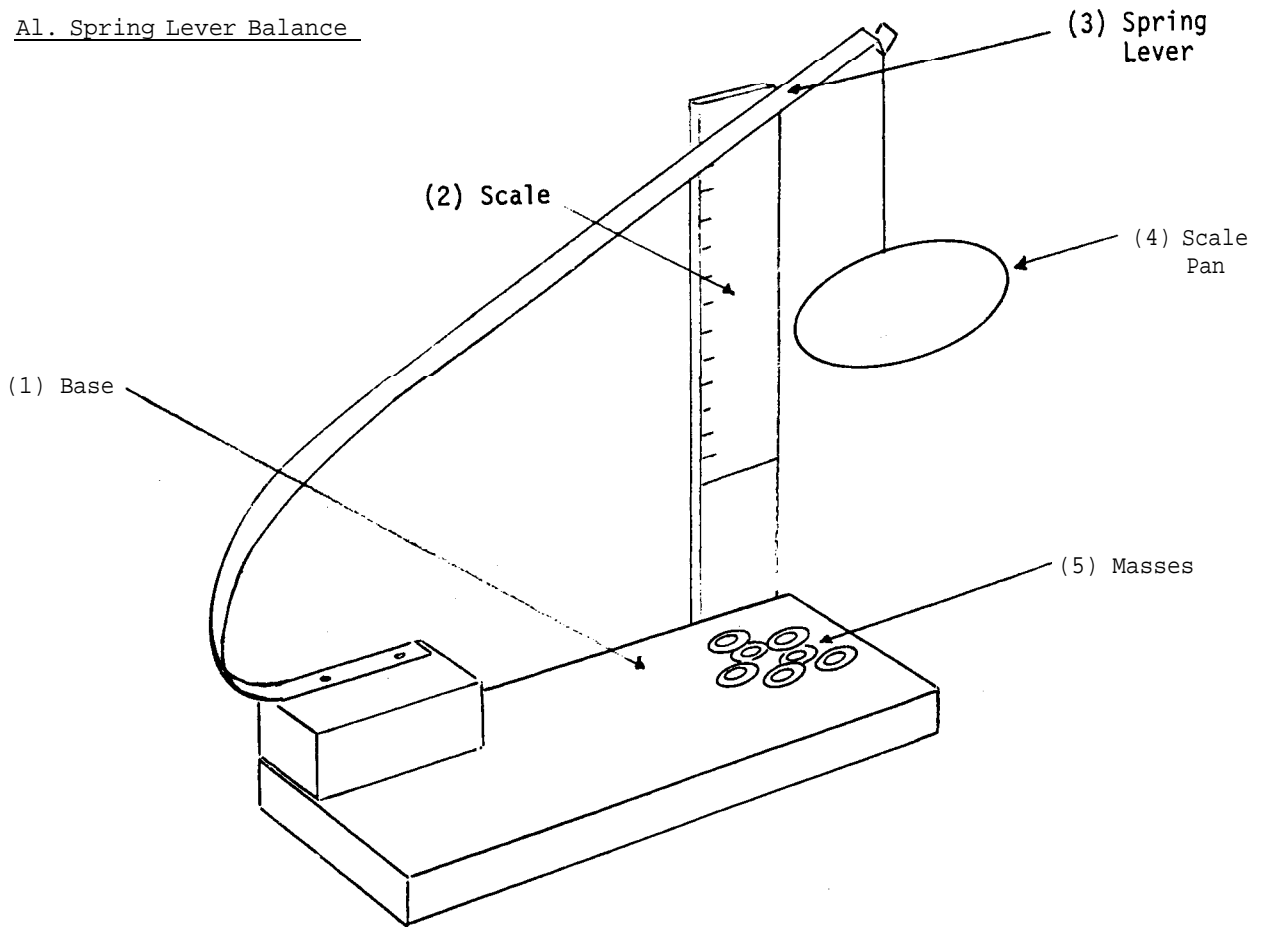

a. Materials Required

<u>Components</u>	<u>Qu</u>	<u>Items Required</u>	<u>Dimensions</u>
(1) Base	1	Wood (A)	13 cm x 6 cm x 1.5 cm
	1	Wood (B)	5 cm x 2.5 cm x 2.5 cm
(2) Scale	1	Wooden Strip (C)	20 cm x 2 cm x 0.5 cm
	1	White Paper (D)	15 cm x 2 cm
(3) Spring Lever	1	Packing Case Steel Band (E)	30 cm x 1.2 cm x 0.02 cm
(4) Scale Pan	1	Galvanized Iron Wire (F)	50 cm length, #24
	1	Aluminum Sheet (G)	5.5 cm x 5.5 cm x 0.02 cm approximately
(5) Masses	---	Washers (H)	--

b. Construction

1) Base

Attach wood (B) to one corner of wood (A) to support the spring lever above the base.

(2) Scale

Attach strip (C) vertically to the adjacent corner of the base. Glue a strip of white paper (D) to the top front surface of strip (C) to serve as a scale.

(3) Spring Lever

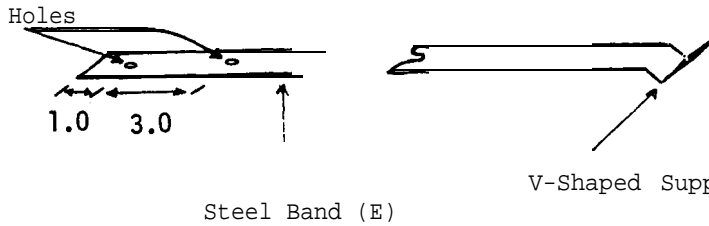

Take packing case steel band (E) and make a small V-shape at one end to hold the scale pan support wire. Drill two holes in the other end to take two small nails.

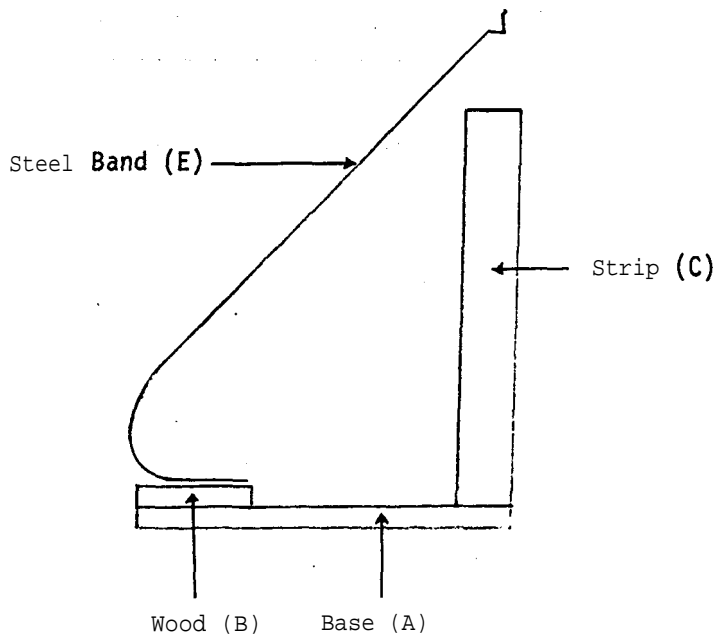

Attach the drilled end of band (E) to the top of block (B) on the base with two small nails. Bend the band smoothly over to form an elongated C-shape as indicated.

(4) Scale Pan

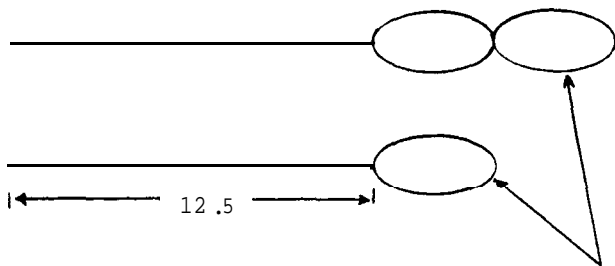

Take the galvanized iron wire (F) and make it into a double strand 25 cm long. Use half of the new length to form a "figure 8" in the wire.

Galvanized Wire (F)

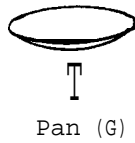
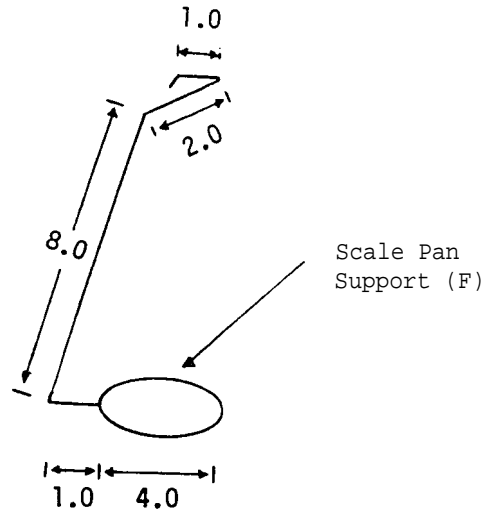

Fold one loop on top of the other, and then bend the remaining straight portion of the wire to the shape indicated. You now have a scale pan support which may be attached to the spring lever.

Make the pan itself from the aluminum sheet (G). Hammer it at the center to create a saucer shaped pan. Sit the pan on the loop of the scale pan support.

(5) Masses

Such items as nails, washers and paper clips may be used for masses,

C. Notes

(i) Note the point of intersection between the spring lever and the left side of the scale, and record the position with a temporary zero mark. Determine the elastic limit of the spring lever by adding successively larger masses to the scale pan, and noting on each occasion whether the spring returned to the same zero point on removing the masses from the pan. **In** this particular case it was noted that the elastic limit was reached with a mass of 33 g.

(ii) Note the new zero point on the scale with a permanent mark. This will be slightly below the temporary mark due to the spring being subjected to a force which extended it slightly beyond its elastic limit. Now add masses 1 g at a time calibrating the scale accordingly up to 20 g.

(iii) A more sensitive balance, weighing from 0 to 10 g, may be made in an identical fashion by using half the width of packing case band as the spring lever, Such a balance made here was found to have an elastic limit of 27 g, and was readily calibrated as described above.

A2. Rubber Band Balance

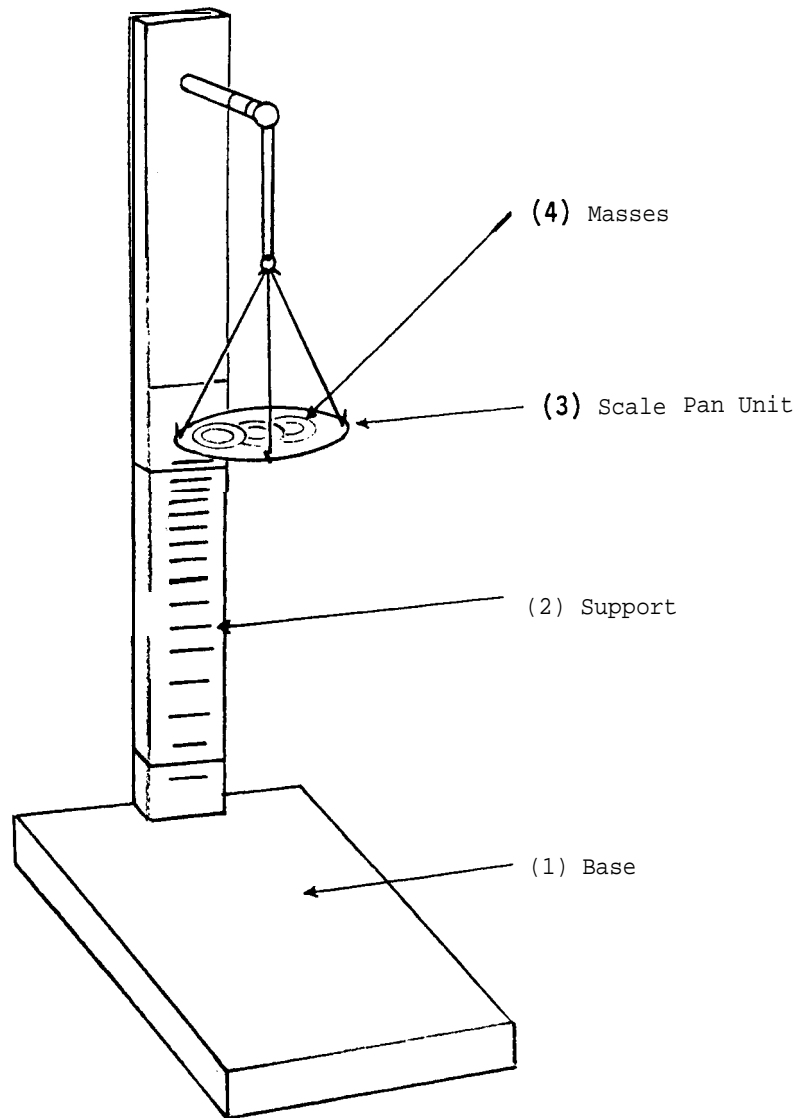

a. Materials Required

<u>Components</u>	<u>Qu</u>	<u>Items Required</u>	<u>Dimensions</u>
(1) Base	1	Wood (A)	15 cm x 10 cm x 1.5 cm
(2) Support	1	Wood Strip (B)	45 cm x 4 cm x 2 cm
	2	Screws (C)	2.5 cm long
	1	White Paper (D)	30 cm x 4 cm
	2	Rubber Bands (E)	--

(3) Scale Pan Unit	1	Nail (F)	7 cm long approximately
	1	Rubber Band (G)	--
	1	Galvanized Wire (H)	#20, 3 cm long
	1	Aluminum Sheet (I)	6 cm x 6 cm x 0.02 cm
	3	Wire (J)	#24, 9 cm long
	1	Adhesive Tape (K)	10 cm x 1 cm
(4) Masses	--	Washers	--

b. Construction

(1) Base

Use wood (A) to serve as the base.

(2) Support

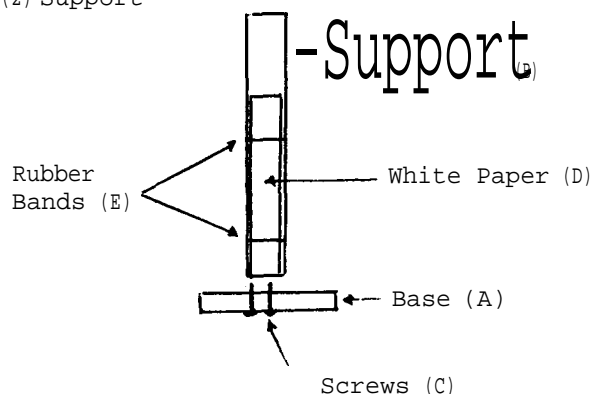

Attach wood strip (B) vertically to the base with two screws (C). Attach the plain white paper (D) to the front of the vertical support (B) with rubber bands (E).

(3) Scale Pan Unit

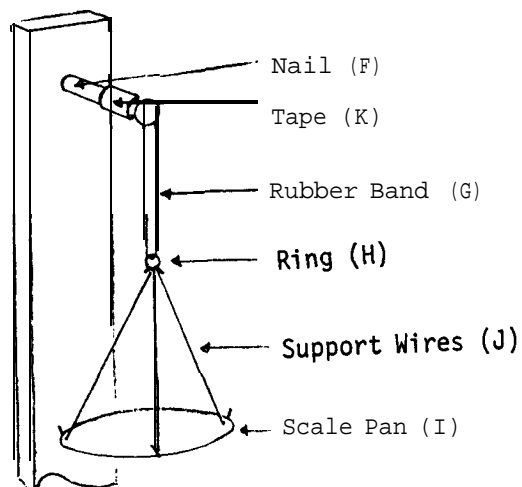

Drive nail (F) horizontally into top of the vertical support, and suspend a rubber band (G) from its end. Take the galvanized wire (H) and bend it into the shape of a ring which can be suspended from the rubber band.

Hammer the aluminum sheet (I) at its center so as to create a saucer shape, thus producing a reasonable scale pan. Use a hammer and nail to produce three small holes near the perimeter of the pan. Suspend the pan from the ring by means of the three lengths of wire (J) bent over at both ends to form suitable hooks.

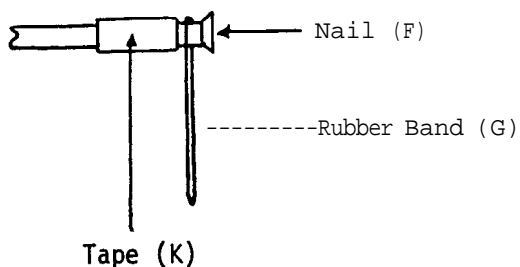

To prevent the rubber band sliding backwards and forwards on the supporting nail a length of adhesive tape (K) should be wrapped around the nail so as to leave a groove between the tape and the end of the nail, the rubber band being held in position in the groove.

(4) Masses

Such items as nails, washers and paper clips may be used as masses.

C. Notes

(i) Note the point on the scale corresponding to the position of the unloaded scale pan. Determine the elastic limit of the rubber band by loading the scale pan with increasing masses, noting in each instance whether the unloaded pan returns to the same zero point on the scale. For the particular band used in this instance the elastic limit was reached with a mass of 235 g.

(ii) Check the zero position on the scale once more, making a permanent mark opposite the scale pan, then calibrate the scale by adding successive weights to the pan, keeping well within the elastic limits of the band.

(iii) A nonuniform scale will result.

(iv) The rubber band will deteriorate with time, and this will be particularly rapid in tropical countries. However, the band can easily be replaced and the scale recalibrated so long as the teacher has a suitable set of weights available.

(v) If the scale pan is suspended from two parallel elastic bands, instead of one, the range and the elastic limit will be increased. With two bands the elastic limit increased in this particular case to 550 g. However, it was noted that if masses of less than 500 g were left on the pan for any period of time there was still a tendency for the rubber band to be plastically deformed.

A3. Simple Beam Balance

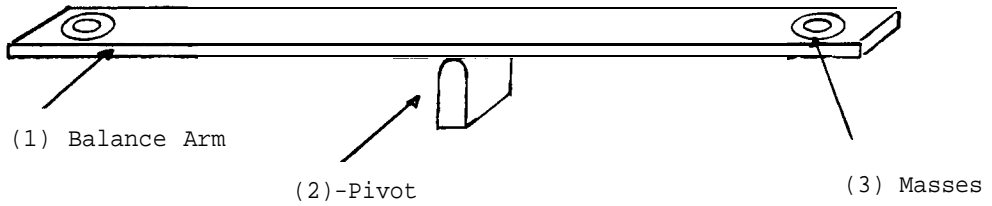

a. Materials Required

<u>Components</u>	<u>Qu</u>	<u>Items Required</u>	<u>Dimensions</u>
(1) Balance Arm	1	Meter Ruler (A)	100 cm long
(2) Pivot	1	Wood (B)	4 c m x 4 c m x 2 c m
(3) Masses	--	Washers (D)	--

b. Construction

(1) Balance Arm

Use the meter ruler (A) as a balance arm.

(2) Pivot

Round off one end of the available piece of wood (B) with sandpaper.



(3) Masses

Use washers or heavy nuts (D) for masses.

B. EXPERIMENTAL BALANCES

B1. Extending Spring Balance

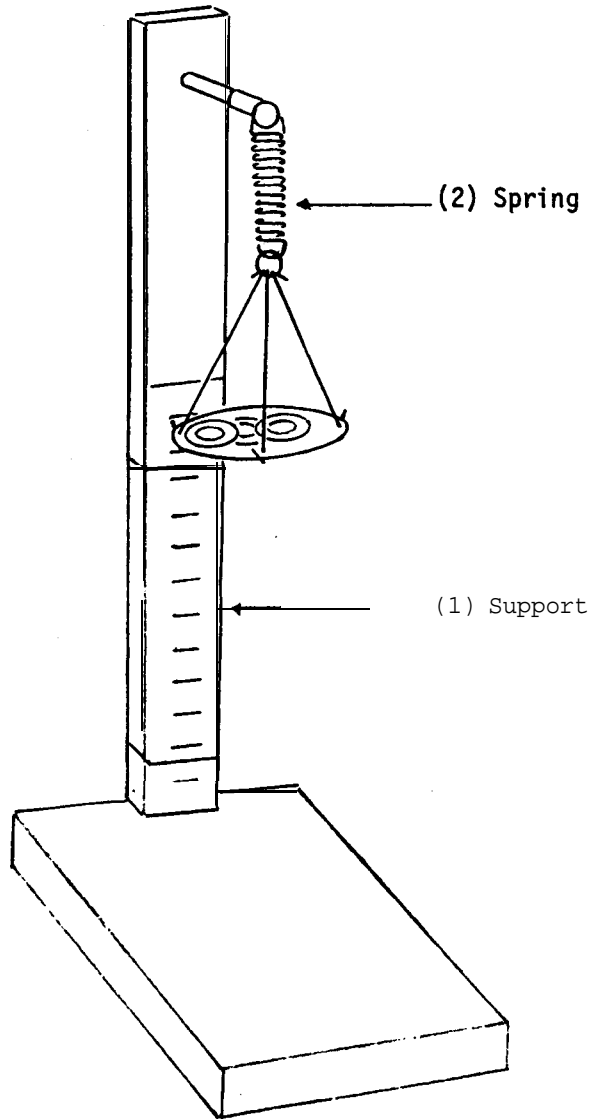

a. Materials Required

<u>Components</u>	<u>Qu</u>	<u>Items Required</u>	<u>Dimensions</u>
(1) Support	1	Rubber Band Balance (A)	I/A2
(2) Spring	1	Steel Wire (B)	0.09 cm diameter, 225 cm long

b. Construction

(1) Support

Make the support (A) in precisely the same way as the rubber band balance described

(2) Spring

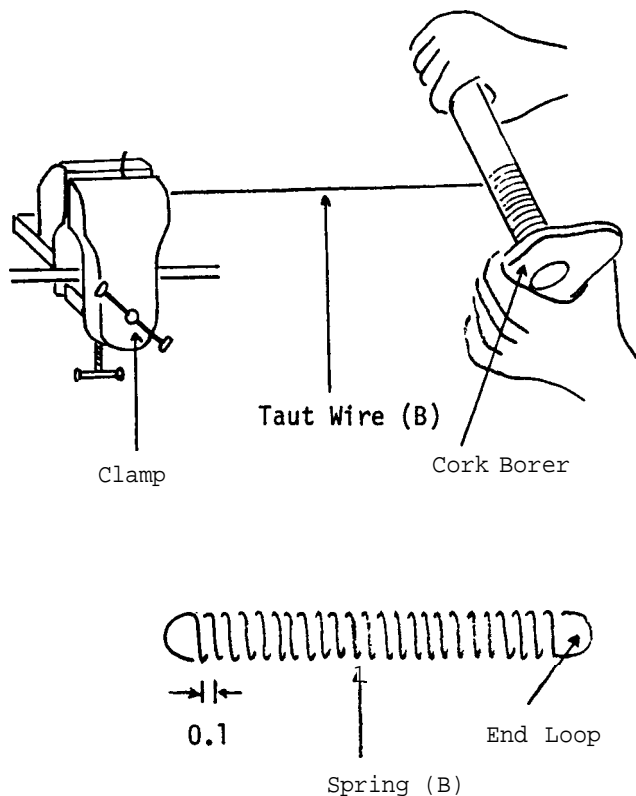

under I/A2,

Take a length of steel wire (B) (e.g. piano wire) and fasten one end firmly in a clamp. Attach the other end to a cork borer or similar device (see notes). If the diameter of the axis of the cork borer used is 1.4 cm, the diameter of the resultant spring (when released) will approach 2 cm. Keeping the wire under tension wind some 30 turns of wire into the spring, each turn being separated from the next by about 0.1 cm. Use pliers to twist a loop in each end of the spring. Remove the rubber band which supports the scale pan in the rubber band balance (A), and replace it by the steel spring.

c. Notes

(i) Determine the elastic limit of the steel spring, and calibrate the balance in exactly the same way as for the rubber band balance.

(ii) With the materials described above the spring was extended until the scale pan touched the base of the apparatus without reaching the elastic limit of the spring. The scale was calibrated from 0 to 400 g (an extension of 19.6 cm), and it was noted that the resultant scale was uniform.

(iii) A more sensitive, or weaker, spring may be made by using thinner wire or by making the diameter of the spring greater,

(iv) A very convenient winding device for the spring is a wooden dowel (in this

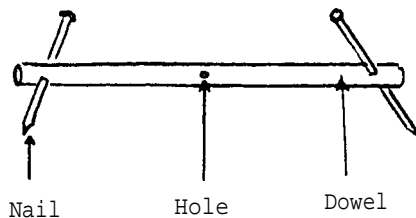

case 1.4 cm diameter, 30 cm long) with a hole (0.6 cm diameter) drilled at either end to take a nail about 10 cm long.

A small hole (diameter 0.2 cm) drilled through the center of

the dowel holds the wire, and the latter may be wound into a spring in much the same way as with the help of the cork borer, in this case winding the wire spring onto the wooden dowel which is turned with the help of the protruding nails.

B2. Compression Spring Balance

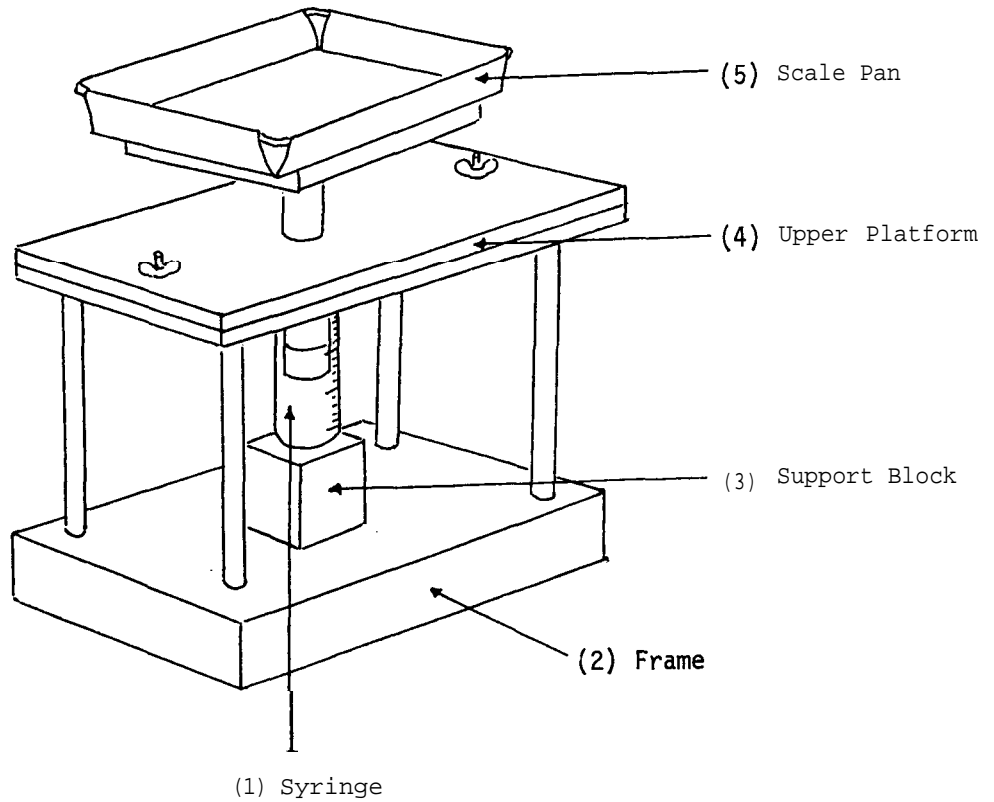

a. Materials Required

<u>Components</u>	<u>Qu</u>	<u>Items Required</u>	<u>Dimensions</u>
(1) Syringe	1	Syringe (A)	Column length approximately 6.4 cm, internal diameter approximately 1.3 cm
	--	Modelling Clay (B)	--
(2) Frame	1	Wood (C)	14 cm x 9 cm x 2 cm
	1	Wood (D)	14 cm x 9 cm x 0.7 cm
	4	Wooden Dowels (E)	12 cm long, 1 cm diameter
(3) Support Block	1	Wood (F)	2 cm x 2 cm x L cm, where L is dependent on length of syringe
(4) Upper Platform	1	Wood (G)	14 cm x 9 cm x 0.07 cm
	2	Bolts (H)	2 cm long, 0.3 cm diameter
	2	Wing Nuts (I)	0.3 cm diameter

(5) Scale Pan	1	Galvanized Wire (J)	32 cm long, 0.4 cm diameter
	1	Aluminum Sheet (K)	12 cm x 12 cm x 0.05 cm
	1	Wood (L)	5 cm x 5 cm x 2 cm

b. Construction

(1) Syringe

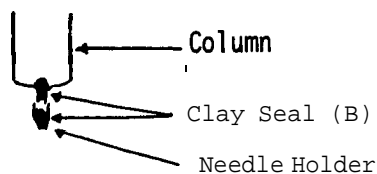
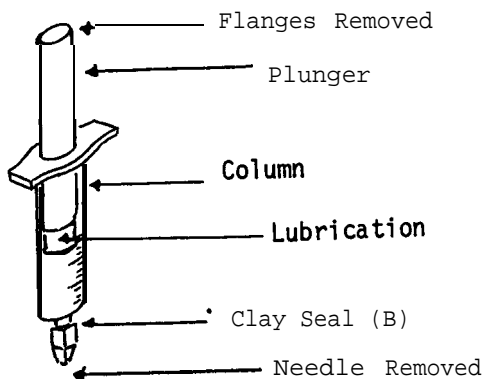

Take the disposable plastic syringe (A) and remove the needle and the top flanges. Remove the plunger from the column, and smear the end of the plunger with petroleum jelly thus insuring a well lubricated plunger, and a good airtight seal.

Insert the plunger about 1 cm into the column, and then seal off the open end of the column with modelling clay with the help of the metal needle holder.

(2) Frame

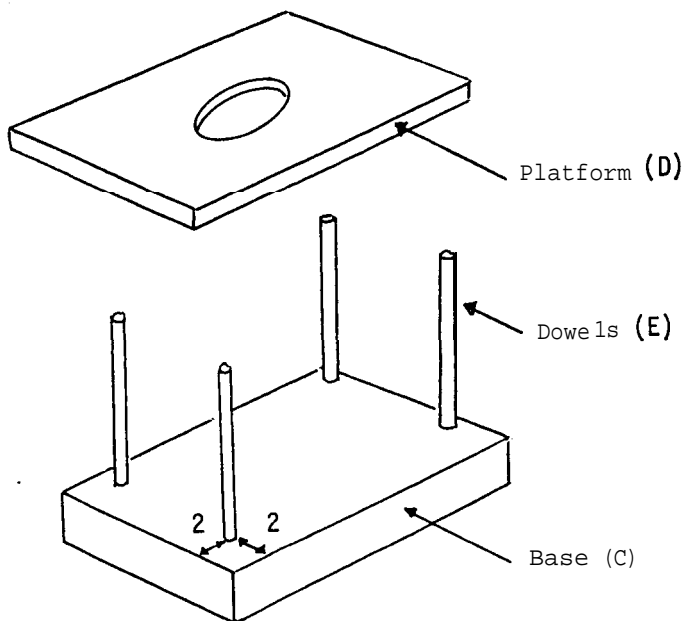

Make the base of the frame from wood (C) drilling holes (1 cm diameter) at the corners to take the dowels (E). Use wood (D) as a platform, drilling holes (1 cm diameter) at each corner to take the dowels. Attach the base and platform together by means of the four dowels, fixing the latter firmly in position with wood cement. Drill a hole (1.4 cm diameter) through the middle of the platform, making it just large enough to take the plunger.

(3) Support Block

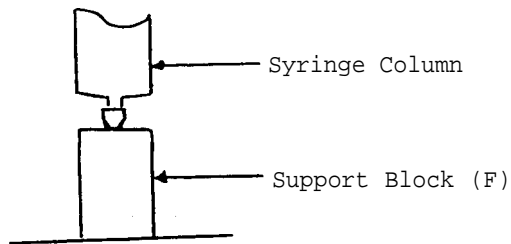

Insert the syringe column through the hole in the platform. It will hang suspended with a gap between the bottom of the syringe and the surface of the base. Cut a small support block (F) to fill this gap, and drill a small inset into the top of the block to hold the syringe firmly in position. (The block will also prevent the modelling clay seal in the bottom of the syringe being readily broken under pressure). Fasten the support block to the base with wood cement.

(4) Upper Platform

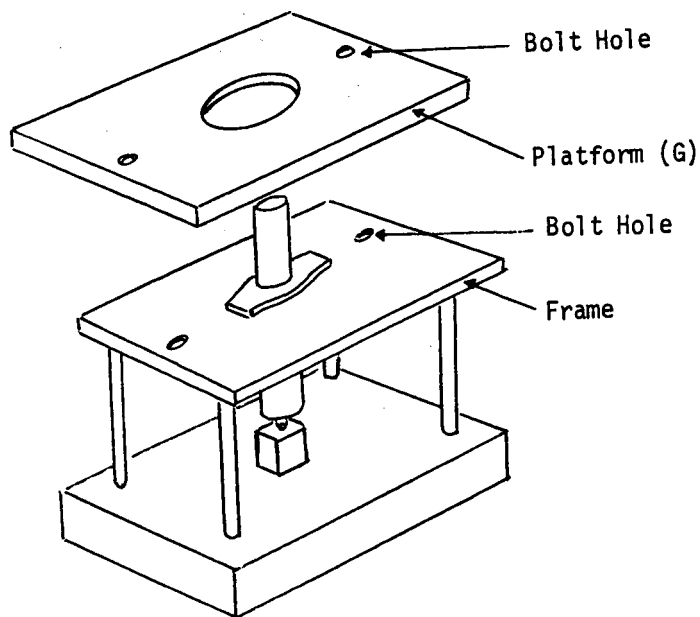

Make the upper platform from wood (G) to fit on top of the existing platform for the frame.

Drill a hole (diameter the same as that of the syringe plunger) in the middle of the upper platform, and slide the latter into position on the frame. Drill two bolt holes (0.3 cm diameter) through both platforms, and fasten them together by means of bolts (H) and wing nuts (I), thus holding the syringe firmly in position.

(5) Scale Pan

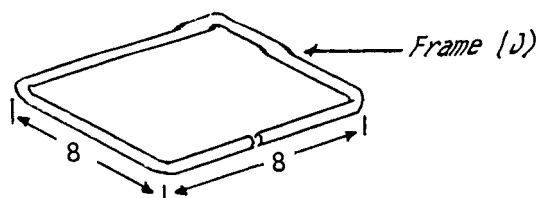

Make a frame for the scale pan out of aluminum or galvanized wire (J).

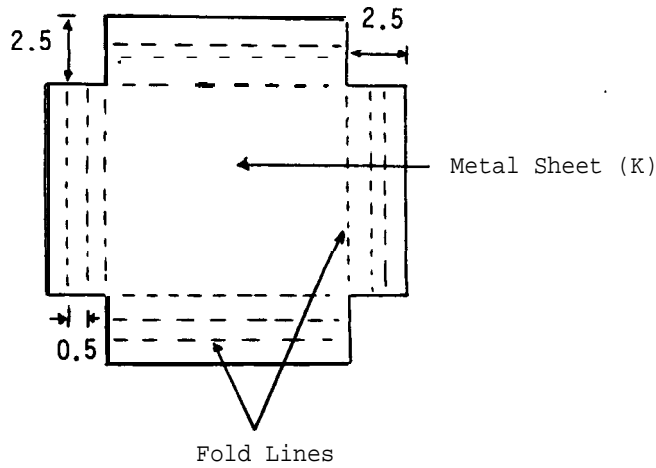

Cut the corners (2.5 cm x 2.5 cm) out of the aluminum sheet (K), and fold the projections as illustrated so that they may be bent over the wire frame to form a suitable scale pan.

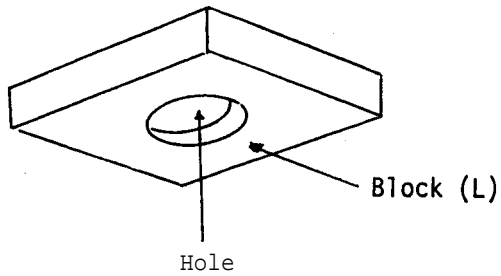
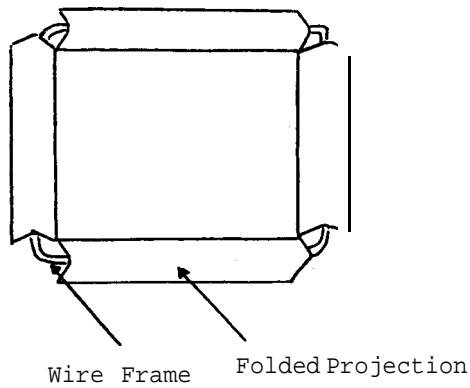

Take the wooden block (L), and drill a hole (the same diameter as the plunger, and 1.5 cm deep) into the middle of the block. Nail the scale pan squarely on to the undrilled surface of the block. Line the inside of the hole in the lower surface with wood filler.

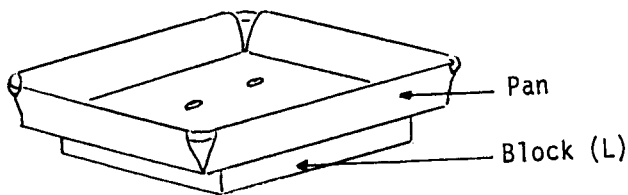

Lower the block onto the plunger. The latter will be held firmly within the hole once the wood filler dries.

c. Notes

(i) The balance may readily be calibrated with known weights by noting the length of the trapped air column for each given mass in the scale pan.

(ii) The variation of length of the air column with mass is not linear, as can be seen from the plot below showing the relationship of air column length (L) to the applied mass (M).

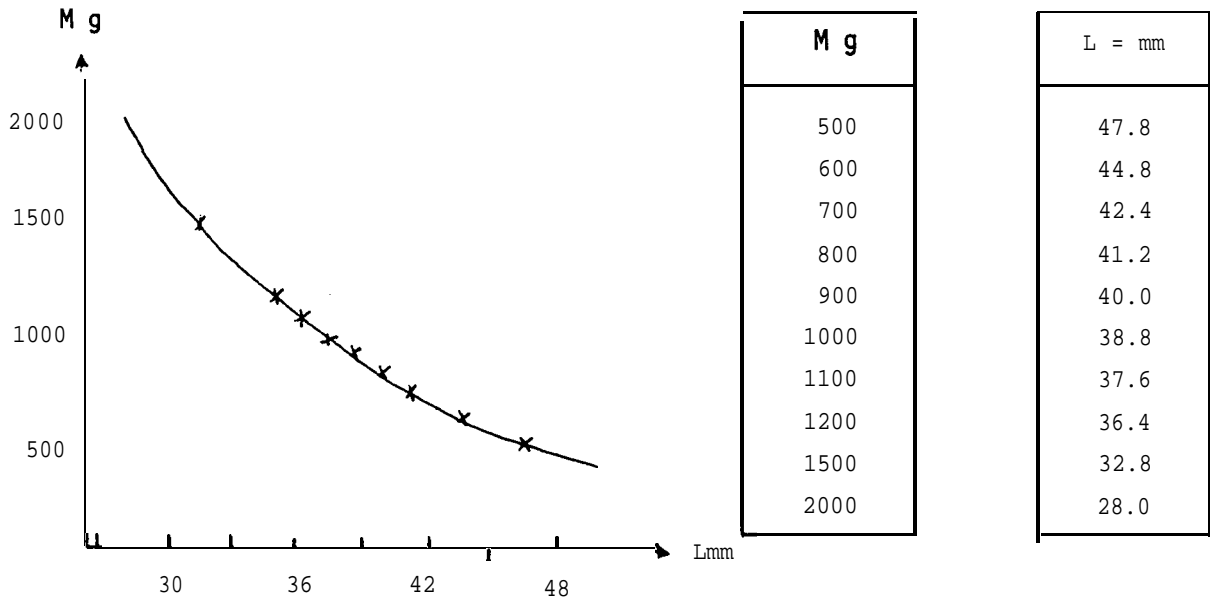

(iii) Because of friction between the plunger and the sides of the column, the syringe tends to be insensitive to weights of less than about 500 g, but it readily measures weights from this lower limit up to around 5,000 g.

(iv) The sensitivity of the balance appears to increase as the length and diameter of the syringe column increases.

(v) In designing new balances it would be of particular interest to consider the use of a syringe as an extension spring, as illustrated in the diagram.

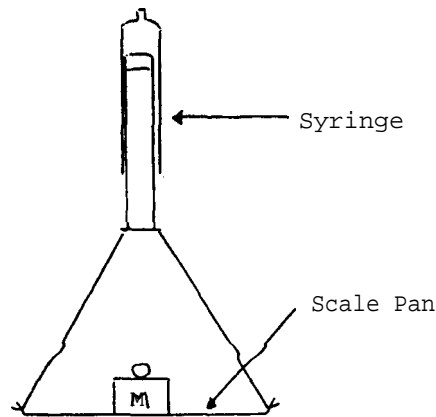

It would appear that this balance might have quite a different range and sensitivity from that of the compression spring balance.

B3. Pegboard Balance

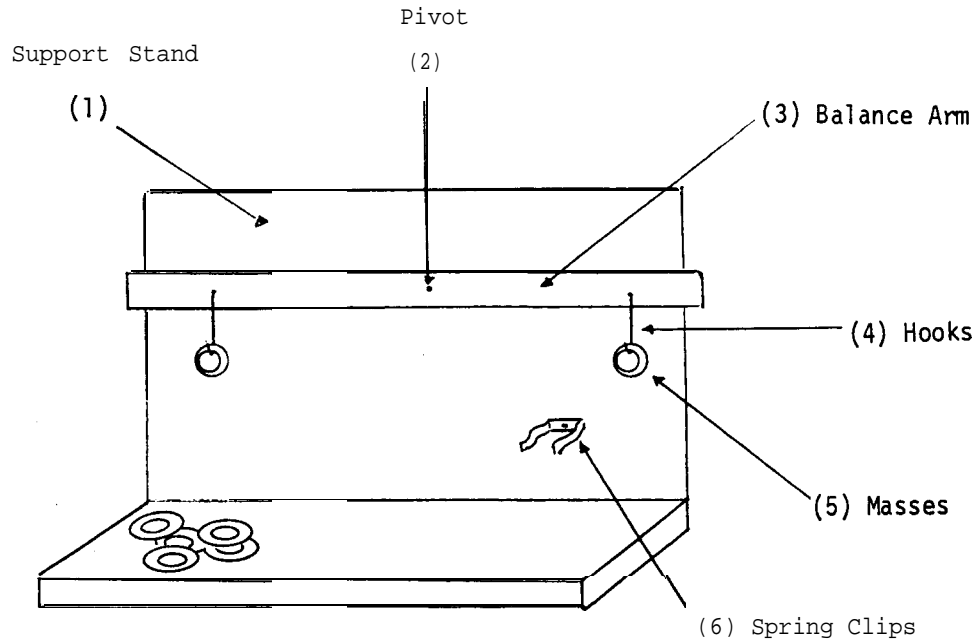

a. Materials Required

<u>Components</u>	<u>Qu</u>	<u>Items Required</u>	<u>Dimensions</u>
(1) Support Stand	1	Wood (A)	50 cm x 10 cm x 2 cm
	1	Pegboard (B)	50 cm x 35 cm x 0.3 cm
(2) Pivot	1	Wood (C)	8 cm x 3 cm x 1 cm
	1	Nail (D)	5 cm long, 0.3 cm diameter
	2	Bolts (E)	2 cm long, 0.3 cm diameter
	2	Wing Nuts (F)	0.3 cm internal diameter
	2	Spring Clips (G)	---
(3) Balance Arm	1	Wood (G)	50 cm x 2.5 cm x 0.5 cm
	1	Aluminum Sheet (H)	2.5 cm x 2.0 cm x 0.02 cm
(4) Hooks	6	Paper Clips (I)	---
(5) Masses	20	Washers (J)	---
(6) Spring Clips	2	Packing Case Steel Bands (K)	8.5 cm x 1 cm x 0.02 cm
	2	Bolts (L)	1.5 cm long, 0.3 cm diameter
	2	Wing Nuts (M)	0.3 cm internal diameter

b. Construction

(1) Support Stand

Attach the sheet of pegboard (B) vertically on to wood (A) to make the support.

(2) Pivot

Drill a small hole (diameter 0.2 cm) through wood (C), and make a small inset over the hole. Drive nail (D) through the hole so that the nail head sits in the inset.

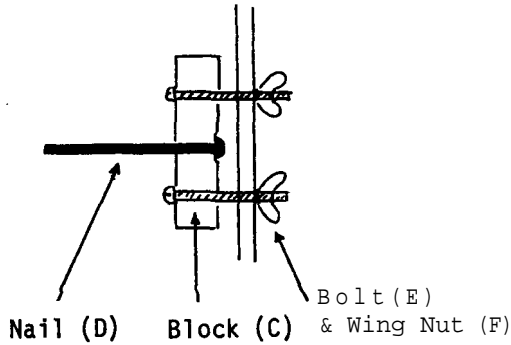

Drill two more holes (diameter 0.3 cm) through the wood, close to the edges, and use bolts (E) and wing nuts (F) to attach the block to the pegboard support stand. The newly attached pivot nail should be at the center of the pegboard and about 20 cm above the base.

(3) Balance Arm

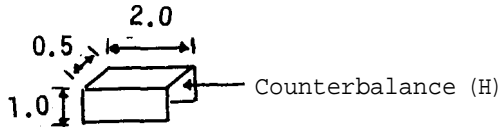

Make the balance arm out of wood (G). Drill holes (0.5 cm diameter) at regular intervals in the arm as illustrated, and balance the arm as required on the nail pivot. Take a sheet of aluminum (H) and bend it into a counterbalance. Set it in an appropriate position on the balance arm to correct any irregularity in the balance of the latter.

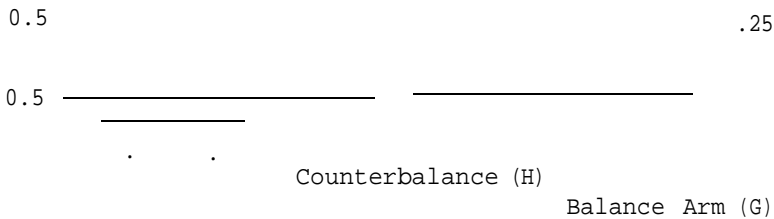

(4) Hooks

Make each hook by straightening out a paper clip (I), and cutting off a length of about 6 cm. Then bend the wire into the shape shown. Make six such hooks.

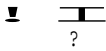

Hook (I)

(5) Masses

Use heavy washers (J) or nuts for masses.

(6) Spring Clips

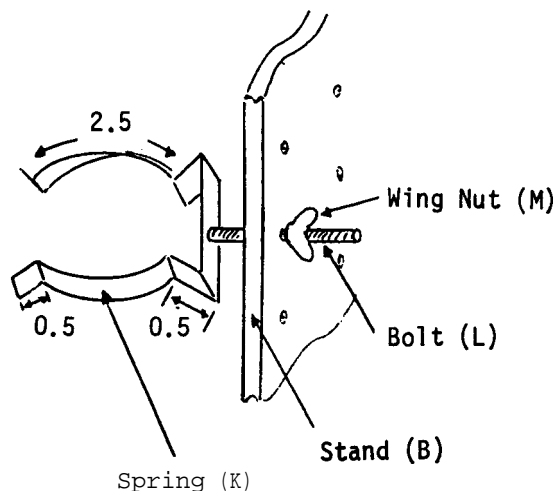

Take a length of packing case steel band (K) and drill a hole (diameter 0.3 cm) through its center. Then bend it as indicated into the form of a spring clip. This size of spring clip is suitable for a standard test tube. Attach this to the support stand with a bolt (L) and wing nut (M). Two identical spring clips should be made.

C. Notes

(i) The position of the pivot in the horizontal lever can be changed at will not only from one end of the lever to the other, but also from the lower edge of the lever to the upper edge (changing the sensitivity of the balance). The apparatus is particularly suitable for studying "moments".

(ii) With the help of the spring clips described the apparatus may be converted into a general support stand.

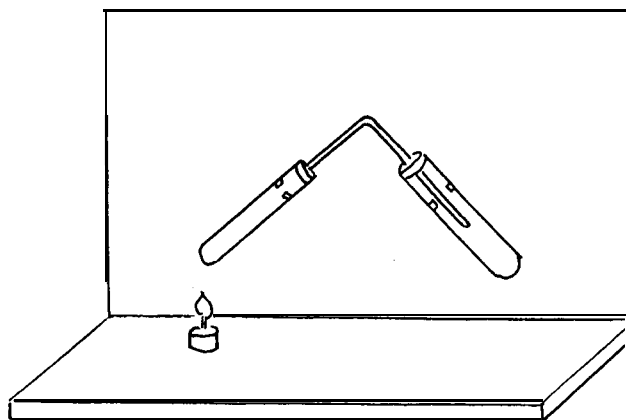

B4. Soda Straw Balance

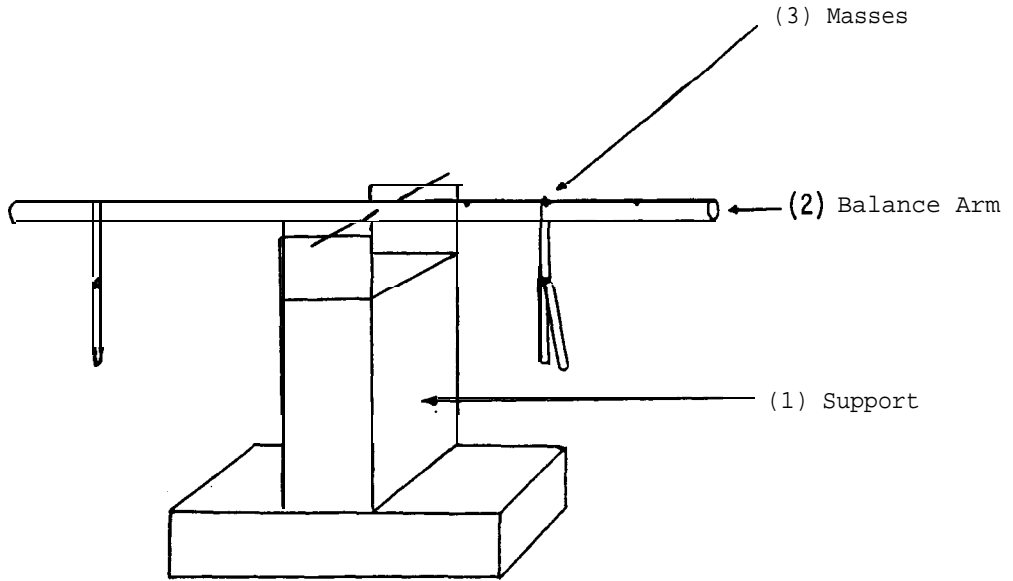

a. Materials Required

<u>Components</u>	<u>Qu</u>	<u>Items Required</u>	<u>Dimensions</u>
(1) Support	2	Wood (A)	6 cm x 2 cm x 2 cm
	1	Aluminum Sheet (B)	6 cm x 2 cm x 0.02 cm
(2) Balance Arm	1	Soda Straw (C)	16 cm long approximately
	1	Needle (D)	3 cm long
(3) Masses	10	Paper Clips (E)	--

b. Construction

(1) Support

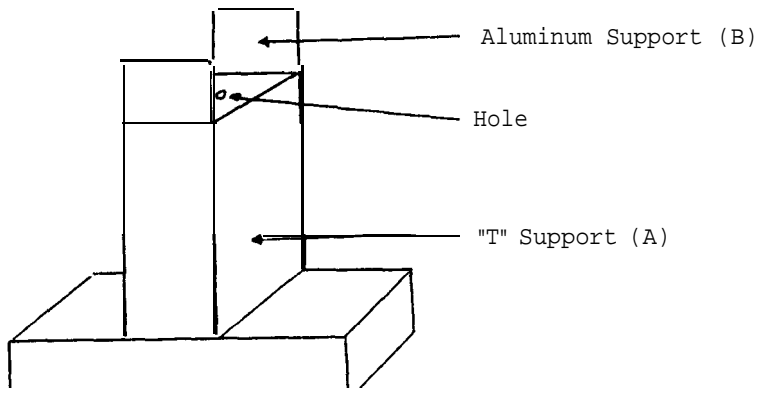

(2) Balance Arm

Screw, or nail, one block of wood (A) on to the other so as to form an inverted sheet (B) and bend this into a three sided support to sit on top of the inverted "T" support. Drill a small hole through the base of the aluminum sheet so that the latter may be attached to the wood support by means of a nail or screw.

Pierce the middle of the straw (C) with needle (D) making sure that the latter is close

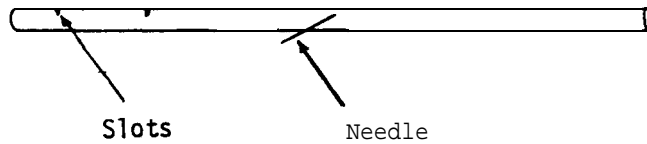

to the top surface of the straw, thus lending stability to the balance arm. Use a razor blade to cut small V-shaped slots in the top surface of the straw at regular intervals of 2 cm. Balance the straw on top of the support.

(3) Masses

Use the paper clips (E) as appropriate masses.

c. Notes

(i) This apparatus is suitable for individual student investigation of the principle of "moments".

B5. Microbalance

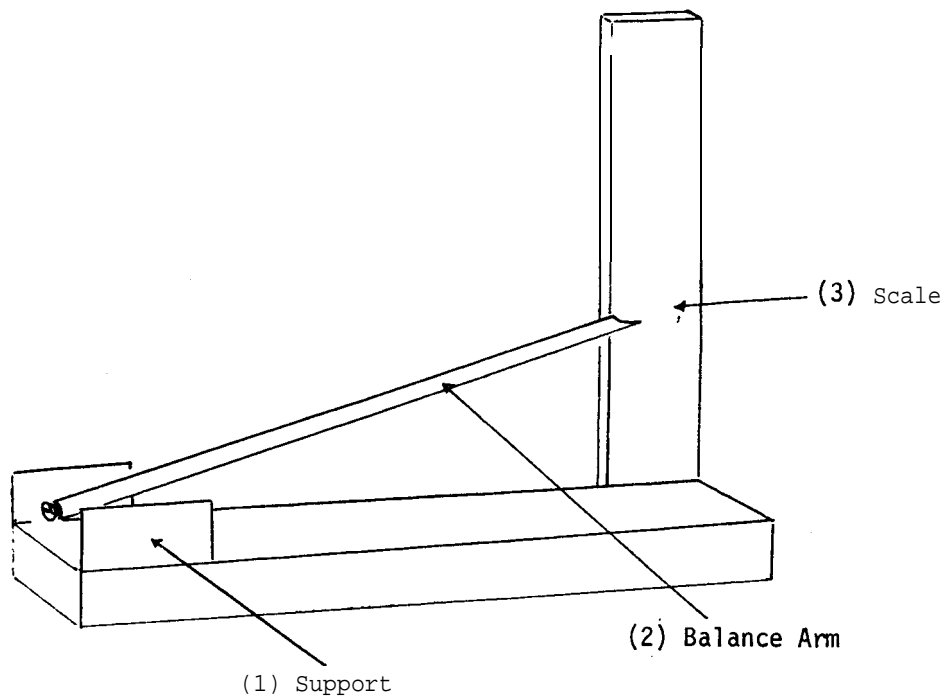

a, Materials Required

<u>Components</u>	<u>Qu</u>	<u>Items Required</u>	<u>Dimensions</u>
(1) Support	1	Wood (A)	15 cm x 2 cm x 2 cm
	1	Screw (B)	1 cm long
	1	Aluminum Sheet (C)	6 cm x 2 cm x 0.02 cm
(2) Balance Arm	1	Straw	16 cm long approximately
	1	Bolt (E)	1 cm long approximately
	1	Needle (F)	3 an long
(3) Scale	1	Wood Strip (G)	12 cm x 2 cm x 0.4 cm
	1	White Paper (H)	10 cm x 2 cm
	2	Rubber Bands	--

Construction

(1) Support

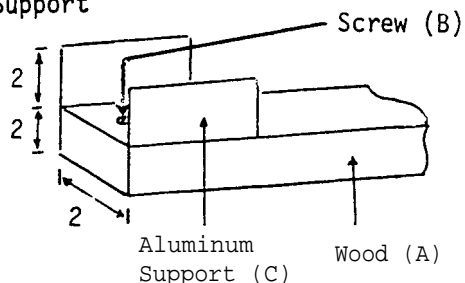

Bend the aluminum sheet (C) into a three sided support. Drill a hole (0.2 cm diameter) through the middle of the support base, and then attach the support to the end of wood (A) by means of a screw

(2) Balance Arm

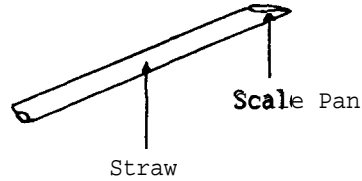

through the hole.

Take the straw (D) and select a short bolt (E) which fits tightly into the end of the straw. Screw the bolt partway into the straw. Cut the free end of the straw with a pair of scissors to make an appropriate scale pan in the balance arm, Pierce the straw near to the top surface, and sufficiently close to one end, with the needle (F) so that the latter will serve as a pivot. Balance the straw on the support. A few trials will be necessary to obtain a suitable position for the needle.

(3) Scale

Nail the wood strip (G) vertically on to the end of the base (A), and attach the piece of white paper (H) to the front surface with rubber bands (I).

c. Notes

(i) The position of the pivot and screw should be adjusted so that the straw points toward the top of the scale. Assuming the weight of a large sheet of paper (or several sheets together) can be determined, calibration may be effected by placing a fraction of a sheet of paper (e.g. 1 square cm or less) on the soda straw scale pan, and noting the depression of the straw on the scale. This balance is sufficiently sensitive to determine the mass of extremely small bodies such as mosquitoes, strands of hair etc.

C. FUNCTIONAL BALANCES

Cl. Equal Arm Balance®

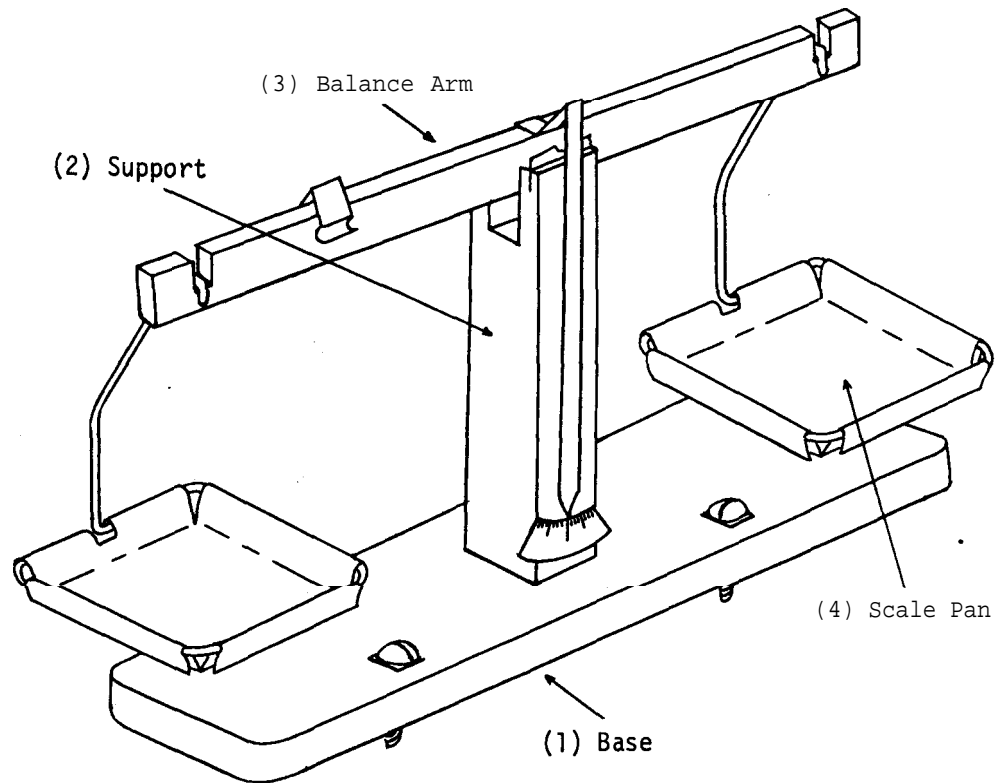

a. Materials Required

<u>Components</u>	<u>Qu</u>	<u>Items Required</u>	<u>Dimensions</u>
(1) Base	1	Softwood (A)	38 cm x 9 cm x 2 cm
	4	Bolts (B)	0.2 cm diameter, 3 cm long
	8	Nuts (C)	0.2 cm internal diameter
(2) Support	1	Screw (D)	3 cm long
	1	Wood (E)	15.5 cm x 3 cm x 2 cm
	1	Razor Blade (F) (Double Edge)	--

© From Regina Melton, Elementary, Economic Experiments in Physics, Apparatus Guide,
(London: Center for Educational Development Overseas, 1972), pp 5-8.

(3) Balance Arm	1	Wood (G)	38 cm x 2 cm x 0.5 cm
	1	Needle (H)	0.1 cm diameter, 5 cm long
	1	Aluminum Sheet (I)	19 cm x 0.5 cm x 0.5 cm
	1	Aluminum Sheet (J)	4 cm x 1.5 cm x 0.05 cm
(4) Scale Pans	2	Aluminum Wires (K)	50 cm long, 0.3 cm diameter
	2	Aluminum Sheets (L)	13.5 cm x 13.5 cm x 0.02 cm
	1	White Paper (M)	4 cm x 2 cm

b. Construction

(1) Base

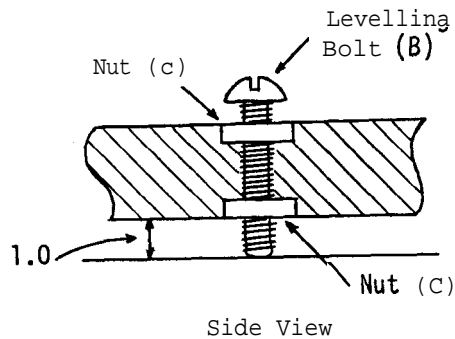
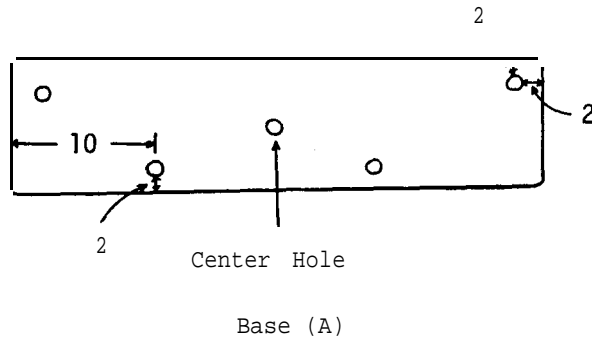

(2) Support

Make the base out of softwood (A). Drill four holes (diameter 0.3 cm) in the base to take the four levelling bolts (B).

Inset the nuts (C) into the base above and below the holes by hammering the nuts into the wood surface. They may be fixed permanently in position with epoxy resin.

Two nuts (C) on each bolt (B) prevent the latter from wobbling, and permit easy hand adjustment of the bolt.

Bore an additional hole (approximately 0.2 cm diameter) at the center of the base to facilitate the attachment of the support.

Cut the support to the shape shown from a piece of wood (E) and cut slots approximately 1 cm deep in the top surface with a saw. Attach the support to the base with the screw (D) inserted through the hole in the center of the base, making a strong junction with the help of wood cement. Then, cut the

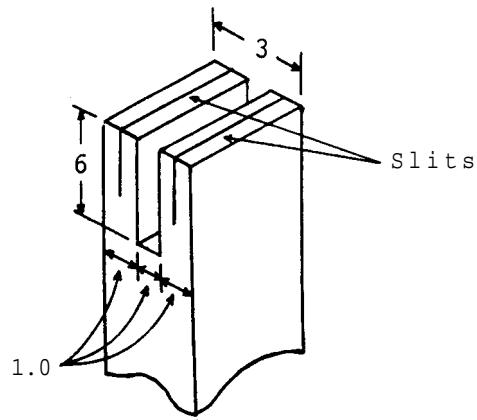

razor blade (F) in half, and, after smearing the cutting edges with epoxy resin, insert the cutting edges of the blades as deep as possible into the slits. The less the blades protrude above the wood the less the strain that is possible on the projecting blades.

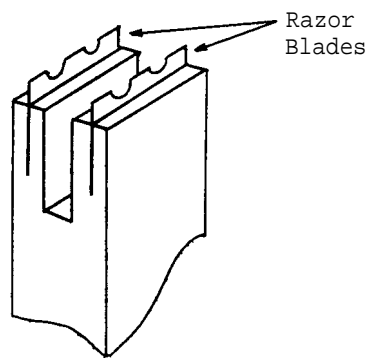

(3) Balance Arm

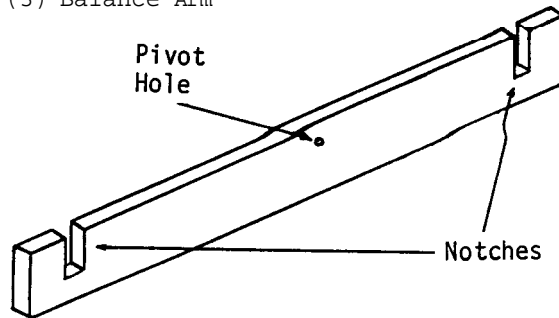

Make the balance arm out of softwood (G), cutting a notch (0.5 cm wide, 1.0 cm deep) at a distance of 1.5 cm from each end of the arm.

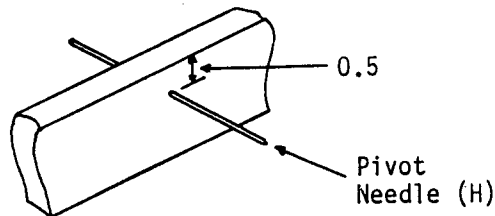

Drill a hole (0.1 cm diameter) horizontally through the middle of the arm at a distance of 0.5 cm from the top of the arm. Drive the steel needle (H) through the hole to serve as a pivot, and glue it permanently in position with epoxy resin.

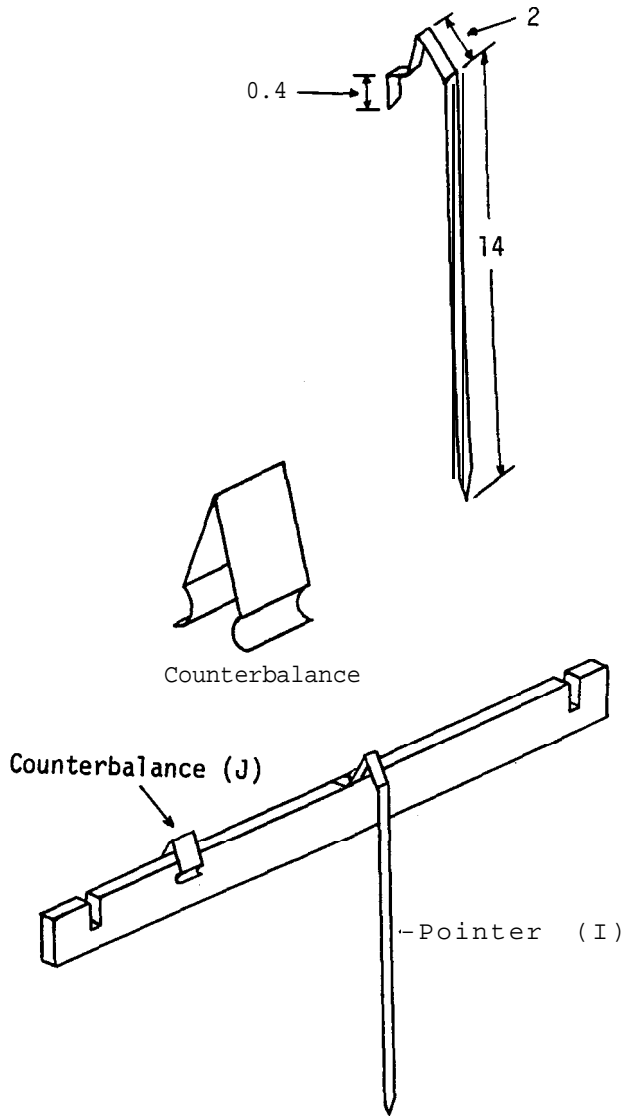

The needle must be sufficiently strong not to bend, even under heavy loads.

Take the sheet of aluminum (I) and bend it into the shape of a pointer as illustrated. Then attach the pointer to the middle of the balance arm.

Complete the balance arm by making a small counterbalance from the sheet of aluminum (J), bending it to the shape indicated. Sit the counterbalance on the balance arm.

(4) Scale Pans

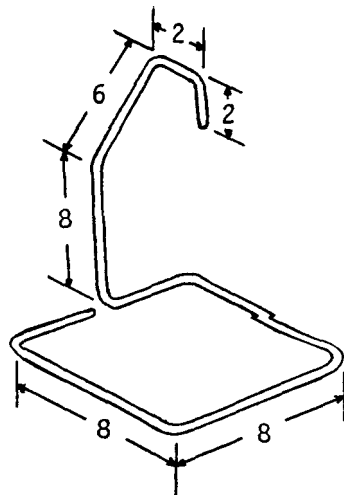

Take the length of aluminum or galvanized wire (K) and bend it into a support for the scale pan. Make an identical support in the same way, and suspend both supports from the notches in the balance arm,

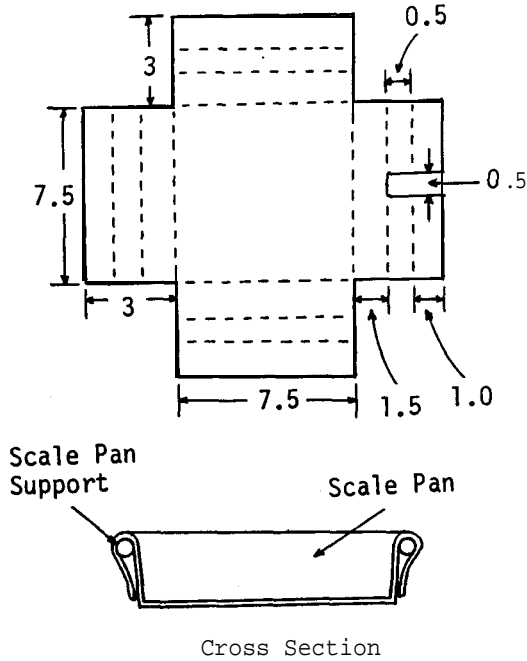

Make the scale pan from the sheet of aluminum (L). Cut squares (3 cm x 3 cm) from the sheet corners to make four projections on the sheet, and cut a slit in one of the projections as indicated. Fold the projections along the dotted lines converting the aluminum sheet into a scale pan with sides. Sit the scale pan on the framework of one of the support wires. Make a second scale pan in an identical manner.

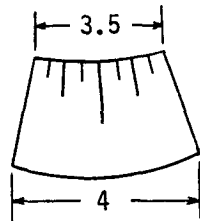
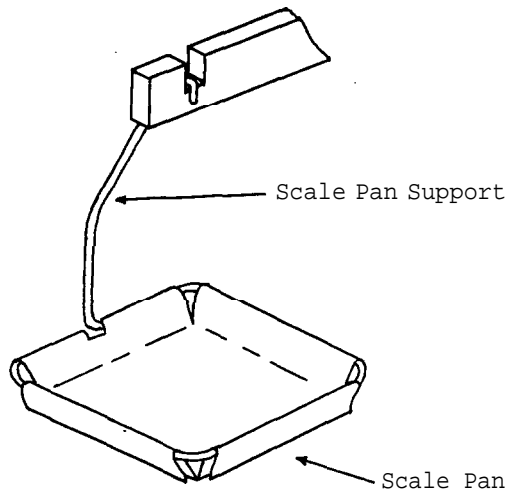

Make a small scale from a piece of white paper (M) by marking regular divisions (0.3 cm apart approximately) on the paper. Glue the scale to the support just behind the pointer so that when the balance arm is perfectly horizontal the pointer will be at the middle of the scale.

c. hates

(i) The following table gives approximate values for the sensitivity of such a balance under varying loads. Sensitivity is measured as the number of milligrams required to cause the pointer to move one millimeter under the given load.

Load in Each Pan	Sensitivity
25 g	25 mg/mm
50 g	25 mg/mm
100 g	65 mg/mm
250 g	200 mg/mm
500 g	335 mg/mm

(ii) As seen in the illustration, the shape of the razor blade edge allows three

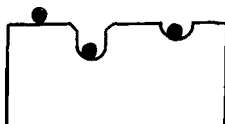

different points to be used as fulcrums for the pivot needle. Sensitivity is found to be essentially the same at all three points for all weights.

(iii) The centering point of the pointer is very stable under varying weight loads. However, if the weights are shifted drastically in position in the pans (that is, off center) then shifts in the pointer position of up to 2 mm may be noted.

C2. Box of Masses ©

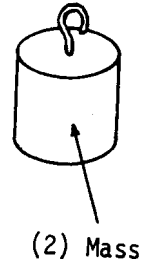
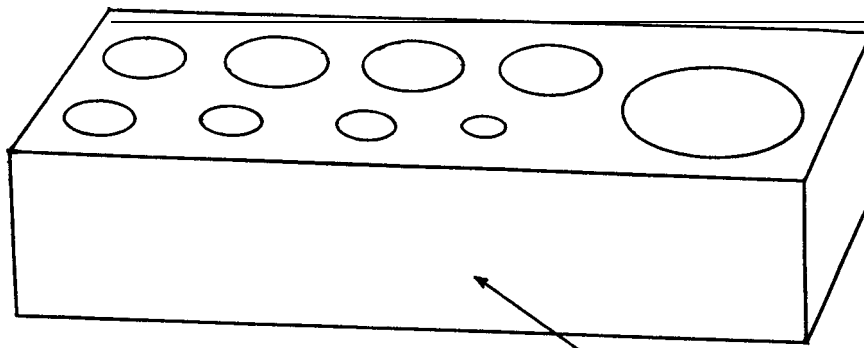

'(1) Box

a. Materials Required

<u>Components</u>	<u>Qu Items Required</u>	<u>Dimensions</u>
(1) Masses	1-3 Lead (A) (sheeting, etc.) 9 Eye Screws (B)	2 kg approximately --
(2) Box	1 Wood (C)	17 cm x 8 cm x 5 cm

b. Construction

(1) Masses

Take a box of wet sand, and use wooden dowels, or some such similar material, to make cylindrical molds in the sand according to the dimensions given below. Heat up some lead (A) in a can, and when it is molten pour it into the molds. Allow the lead to solidify and cool. Then screw into the top of each lead cylinder a cup screw (B) to serve as a handle.

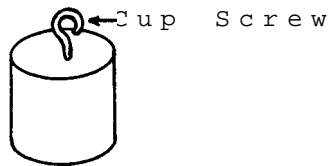

The lead cylinders may then be filed down until each is the desired mass. The number of masses required, and the

approximate size of each mold,
is indicated below.

Qu	Weight	Diameter	Depth
1	500 g	3.8 cm	4.0 cm
3	200	2.4	4.0
1	100	2.4	2.0
1	50	2.4	1.0
2	20	1.2	2.0
1	10	1.2	1.0

(2) Box

Take the block of wood (C) and
drill holes, the same size as
the above molds, into the top
surface. These will serve as
suitable mass holders.

C3. Single Pan Balance

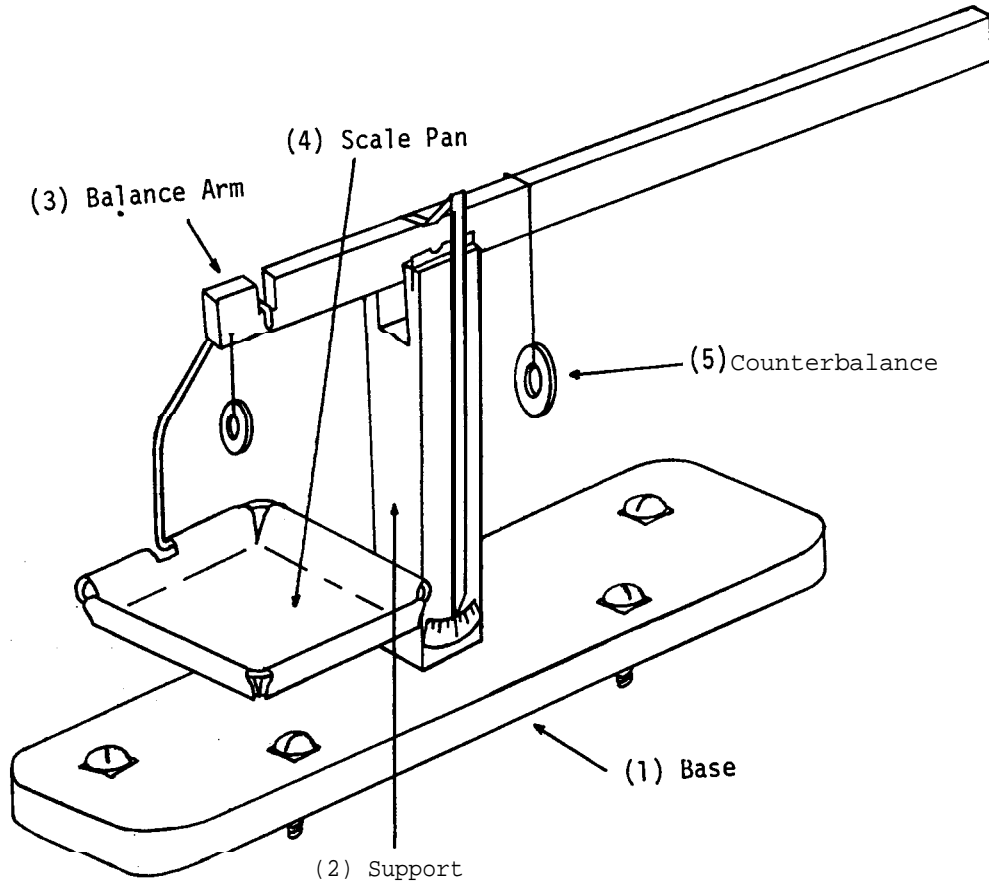

a. Materials Required

<u>Components</u>	<u>Qu</u>	<u>Items Required</u>	<u>Dimensions</u>
(1) Base	1	Equal Arm Balance Base (A)	I/ClComponent (1)
(2)Support	1	Equal Arm Balance Support (B)	I/ClComponent (2)
(3) Balance Arm	1	Soft Wood (C)	42 cm x 2 cm x 0.5 cm
	1	Needle (D)	5 cm long
	1	Aluminum Sheet (E)	19 cm x 0.5 cm x 0.05 cm
(4) Scale Pan	1	Equal Arm Balance Scale Pan	I/ClComponent (4)
(5) Counterbalances	--	Washers (F)	Approximately 70 g total
	--	Washers (G)	Approximately 12 g total
	2	Paper Clips (H)	--

b. Construction

(1) Base

Make the base (Component 1) of the Equal Arm Balance (I/Cl) and use it as the base (A) of

(2) Support

of this item.

Make the support (Component 2) of the Equal Arm Balance (I/C1) and use it as the support (B) of this item.

(3) Balance Arm

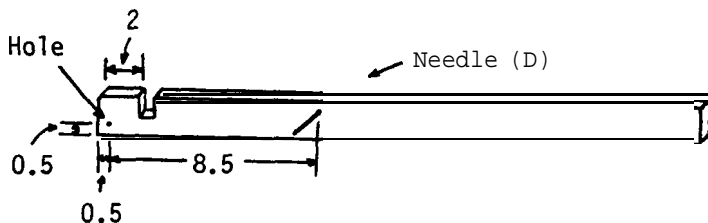

Make the balance arm from the soft wood (C). Drive the needle (D) horizontally through the arm 9 cm from one end and 0.5 cm from the top surface. Cut a notch (0.5 cm wide, 1.0 cm deep) in the top of the arm and drill a small hole (0.2 cm diameter) through the corner of the wood.

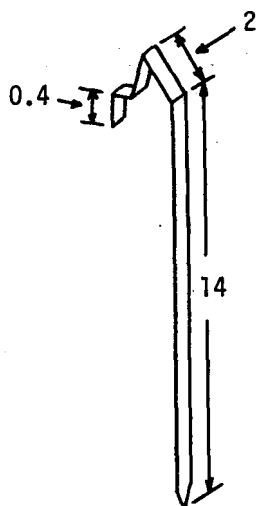

Take a sheet of aluminum (E) and bend it into the shape of a pointer as illustrated. Then attach the pointer to the arm just above the pivot.

Sit the balance arm on top of the support so that the needle serves as a pivot.

(3) Scale Pan

Make the scale pan (Component 4) of the Equal Arm Balance (I/C1), and suspend it from the notch in the balance arm.

(4) Counterbalance

If it is desired to use the balance to weigh the masses up to 300 g, a standard 300 g mass should be placed in the scale pan and washers (F) should be suspended from a paper clip (H) to make counterbalance (I).

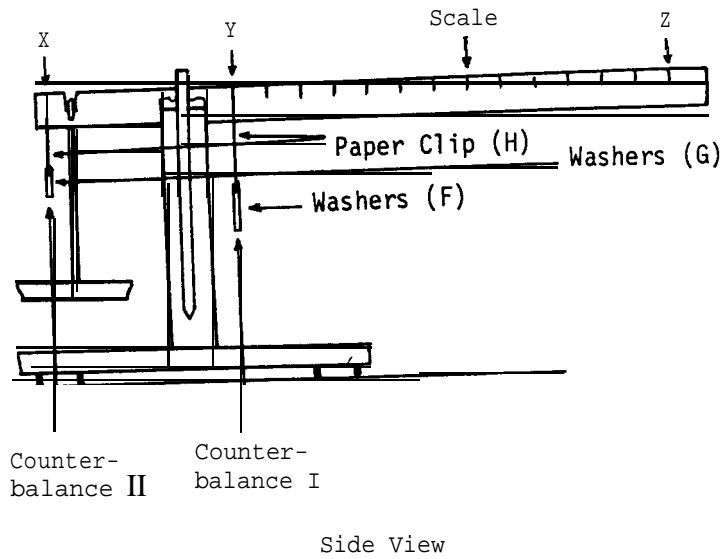

The latter should be such that when it is suspended from the end of the balance arm (position Z) it will just balance the 300 g mass. (In this particular instance two washers weighing a total of 70 g were found to be ideal.)

The counterbalance should then be moved to a suitable zero position (Y) on the arm. The balance arm will not remain horizontal. Therefore make a second counterbalance II from the small washers (G) such that when these are suspended from the end of the arm (position X) they will just balance the arm in a horizontal position with counterbalance I in the zero position (Y). (In this instance washers weighing a total of 12 g made a suitable counter-balance II).

You are now ready to calibrate the scale. Stick a piece of paper to the balance arm with adhesive tape to facilitate the marking of the scale. Then place standard masses (50, 100, 150, 200, 250, 300 g) in the scale pan, and in each instance determine the position of the counterbalance (I) which balances the arm. A uniform scale should be created, and this may be subdivided as desired.

c. Notes

(i) Alternative scales may be produced in an identical manner simply by altering the magnitude of counterbalance I (leaving the mass of counterbalance II the same as before). For example using only one washer (35 g) for counterbalance I a scale from 0 to 140 g was created on the same balance.

C4. Spring Balance ©

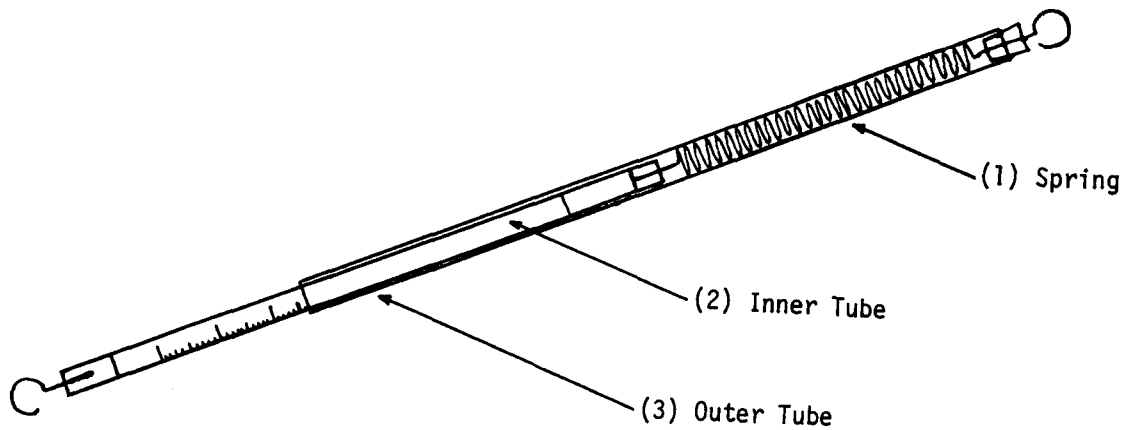

a. Materials Required

<u>Components</u>	<u>Qu</u>	<u>Items Required</u>	<u>Dimensions</u>
(1) Spring	1	Roll of Steel Wire (A)	#26 gauge (for 10 Newton Balance)
	1	Roll of Steel Wire (B)	#30 gauge (for 1 Newton Balance)
(2) Inner Tube	1	Hollow Aluminum Tube (C)	21 cm long, internal diameter 1 cm
	2	Wood Stoppers (D)	1 cm diameter, 2 cm long
	1	Cup Screw (E)	--
(3) Outer Tube	1	Hollow Aluminum Tube (F)	27 an long, internal diameter 1.3 cm
	1	Wood Stopper (G)	1.3 cm diameter, 2 cm long
	2	Cup Screws (H)	--

b. Construction

(1) Spring

The most important factor in winding a spring is to keep the wire taut at all times, and for this the help of a

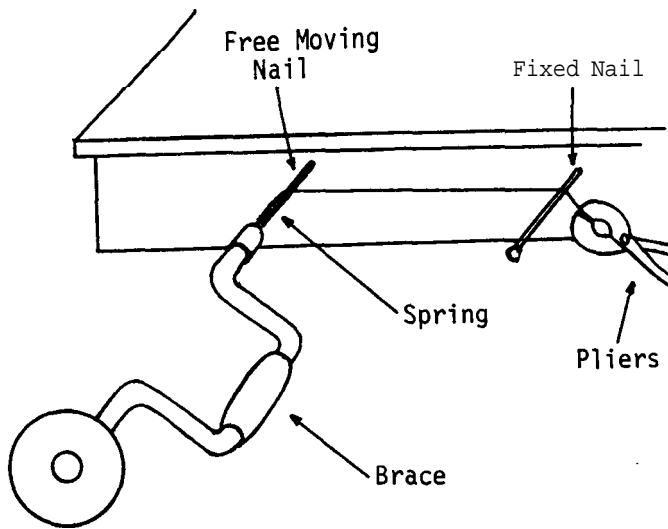

brace and two nails (10 cm long, 0.7 cm diameter) is invaluable. Drill a horizontal hole about 3 cm deep in the bench for the free moving nail, and about 20 cm to the right of this drive in a second (fixed) nail. Clamp one end of the wire (A/B) along with the head of the free nail in the jaws of the brace, and get your partner to hold the other end of the wire in the jaws of a pair of pliers, keeping the wire taut with the assistance of the fixed nail. Turn the brace, winding the wire firmly around the free nail, The spring may be close wound (each turn touching the next) or open wound (each turn separated from the next by a fixed distance). Although the wire is wound on a nail of diameter 0.7 cm, on release from tension it will tend to expand to about 1 cm diameter.

If a Newton balance is to be made take the #26 gauge steel wire (A) (diameter 0.07 cm) and open wind it (0.1 cm between each turn) into a spring approximately 8 cm long and 0.9 cm in diameter.

Make a loop on one end of the spring (using dog nosed pliers) and a straight piece on the other end.

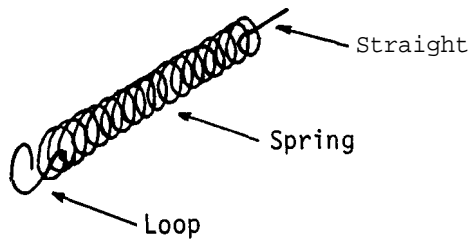

(2) Inner Tube

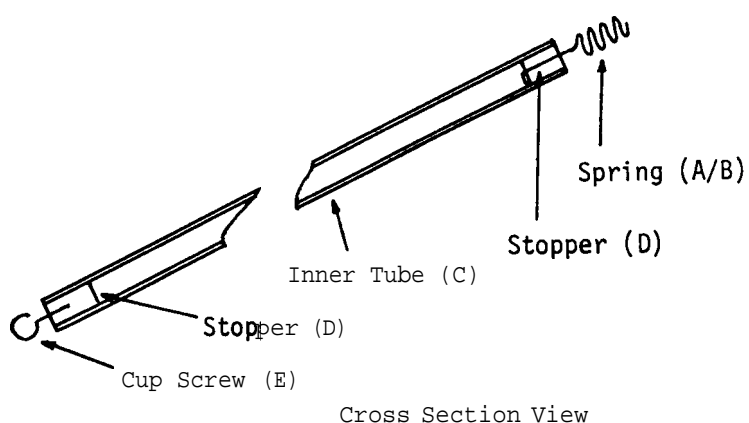

Make two stoppers out of the wood (D). Fix a cup screw (E) into one of the stoppers and glue it permanently into one end of the aluminum tube (C). Drill a small central hole through the other stopper (D) and insert the straight end of the spring, bending the end over to hold it in position. Glue the stopper into the other end of the tube.

(3) Outer Tube

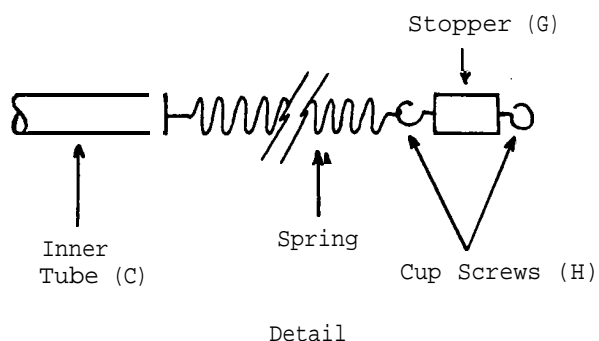

Make a wooden stopper (G) to fit one end of the hollow aluminum tube (F). Fix cup screws (H) in either end of the stopper, and attach the top of the spring to one of the cup screws,

Now take the combination of stopper, spring and inner tube, and lower it into the outer tube (F) until the stopper lodges in the top of the tube. Glue the stopper firmly into the tube.

C Notes

(i) To calibrate the 10 Newton spring, hold the balance vertically, and mark the inner tube opposite the lower end of the external tube (10 Newtons). Suspend 1,020 g from the spring and once again mark the inner tube opposite the lower end of the external tube. Then subdivide the distance between the two marks into 100 equal divisions, thus permitting the balance to read from 0.0 to 10.0 Newtons with an accuracy of 0.1 Newtons.

(ii) To calibrate the 1 Newton spring simply suspend a mass of 102 g from the balance and repeat the above process, calibrating the inner tube from 0.00 to 1.00 Newtons with an accuracy of 0.01 Newtons.

(iii) Spring balances are very easily damaged by over extension of the spring. It is therefore useful to make some simple device to prevent over stressing the spring.

One such method is to tie a piece of magnet wire (diameter 0.05 cm) around the inner cylinder, just above the final marking on the scale, If the lower perimeter of the outer tube is then tapped gently all around it, the magnet wire will be unable to move beyond this point, thus preventing over extension of the spring.

