

Built of bird's-eye maple, this Colonial table is sure to draw compliments for the craftsmanship that took place in your shop



to Build

By DAVID WARREN

With space at a premium in most Colonial homes, the local cabinetmaker was frequently called upon to build a piece of furniture that performed more than one function. This table is typical of such pieces. In addition to its basic role, it was often used—with the top tilted—beside the hearth; the top reflected warmth to where it was wanted.

Though many tilt-top tables were

dry, transfer the outline, using the template, and cut the top. To reduce top thickness to 5/8", scrape or sand 1/16" off each side. I found that a hand plane had a tendency to chip out some of the "eyes" of the maple. A belt sander with a me-

dium-grit belt is better. (If any eye voids do result, they can be filled with tinted wood putty after staining.) Round the edge using a 1/4" quarter-round cutter in your router. If you lack power, it can be rounded with a spokeshave.

In the long run, you'll save time by preparing a full-size drawing of the post and one leg. Transfer three leg outlines onto 7/8" stock and cut out the legs. Use a disk sander to finish the outside curve, a drum sander on the leg's inner curve. Shape the top edge of the legs, mark and cut the dovetails with a fine saw. Using a gouge, work the shoulder of the dovetail concave, so it will fit the curved post snugly.

Turning the post. Take all dimensions for the post from your drawing. Note: The top pin is turned 1 1/2" in diameter to allow for the 1"-square tenon. Since maple seems to be particularly susceptible to cross-grain scratches, sand the post carefully with 6/0 (220 grit) paper. Burnishing the piece with a scrap of leather while it spins in the lathe polishes the surface and reveals these scratches; it

[Continued on page 212]

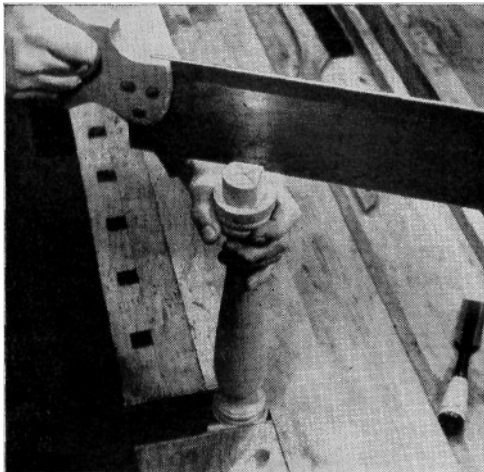

Square, wedged tenon provides good gluing surface, should be cut using mortise in crow's nest as guide.

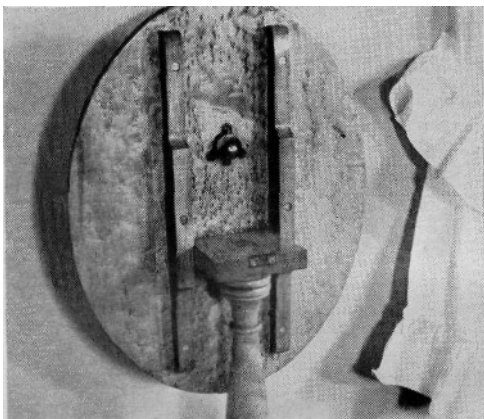

Authentic tilt-table catch, visible with top vertical, holds top fast when positioned horizontally.

Dovetail sockets are cut with drill and small chisel. Leg dovetail serves as pattern for marking.

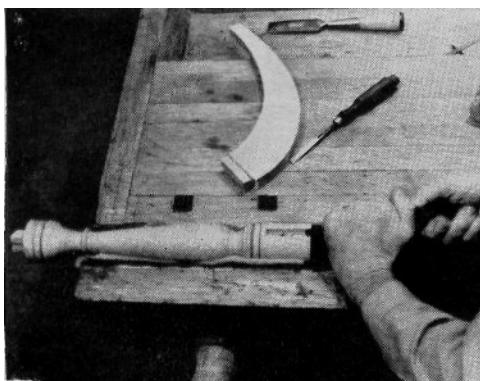

List of materials

Bird's-eye maple

3 pcs. 3/4" x 5 1/2" x 20" (top)

White maple

1 pc. 2 1/2" x 2 1/2" x 18" (post)
 1 pc. 7/8" x 9 3/4" x 1 8" (legs)
 1 pc. 7/8" x 4" x 4" (crow's nest)
 1 pc. 3/4" x 3" x 15" (cleats)

Hardware

Horton Brasses' tilt-table catch No. 48
 3 furniture glides, 1/2"
 No. 8 F.H. brass wood screws, two 1 1/4",
 four 1 1/2"

Misc.

Glue, stain, linseed oil, varnish, 3/8"-by-3" dowel rod

Dust particles are knocked off prior to waxing by smoothing varnish with pumice stone and water.



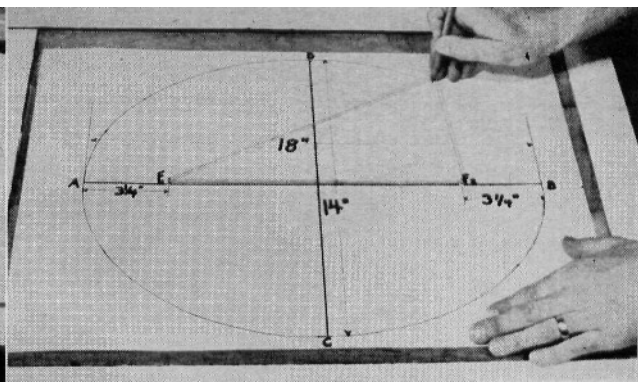
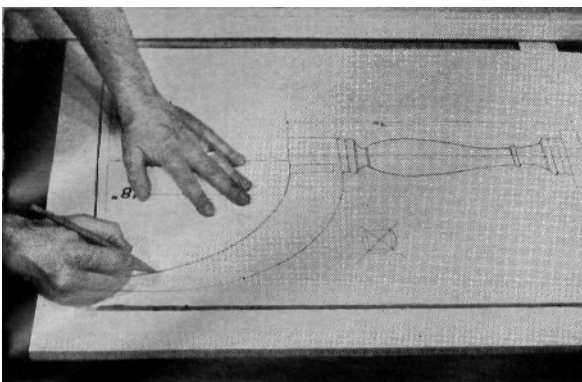

Quarter section of cardboard template for top serves as guide for marking legs. To make top template (photo right), draw 14" and 18" intersecting lines at right angles. Drive a 2d nail $3\frac{1}{4}$ " in from each

end of the longer line and at one end of the 14" line. Tie string tightly around all three nails; remove the nail on the 14" line. To draw accurate ellipse, hold pencil vertical, keep string taut as pencil moves.

Boards for top are tongue-and-grooved, glued, and clamped. For best appearance, grain runs with cleats.

After cutting to shape, sand top down to $5/8$ " thickness. Then edge is rounded with spokeshave.

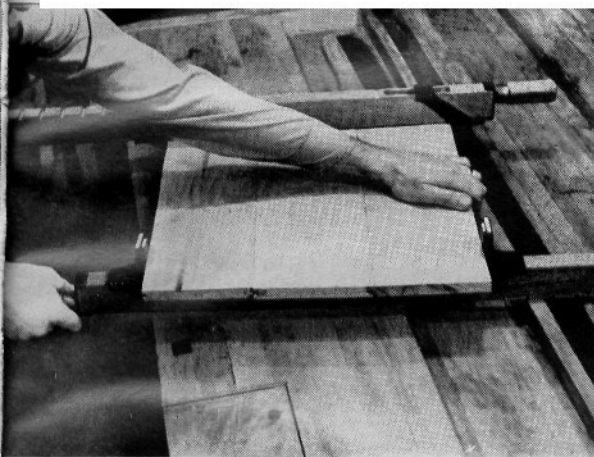

a Tilt-Top Table

larger (some served for dining), the size of this one makes it ideally suited for use as an occasional, or end, table. With top tilted, it takes little space when stored against a wall and it's easy to move around to serve as a snack table wherever needed.

Since the top is in full view when vertical, I made mine of bird's-eye maple. Its distinctive figured grain is decorative and adds an authentic look to the piece. All other wood members are of white maple. Both are available from woodworking-supply houses such as Craftsman Wood Service Co., 2727 S. Mary St., Chicago

60608, and Albert Constantine, 2053 Eastchester Rd., Bronx, NYC 10461.

Laying out the table. The top is an ellipse, not an oval, with 14"-semicircle ends. Using the string-and-pencil method shown, lay it out on a piece of cardboard. To insure symmetry, score the template in quarter sections and fold it to check the edge in both length and width. If necessary, trim it with sharp scissors or a utility knife until the edges match perfectly.

After cutting tongues and grooves, glue and clamp the boards for the top. When

Continued

How to Build a Tilt-Top Table

[Continued from page 178]

may also cut down the amount of stain the wood absorbs.

After removing the post from the lathe, locate the three dovetail sockets. Using the leg dovetails you've cut as a pattern, mark and cut the sockets. Bore the waste stock in the sockets with a 3/8" drill and finish cleaning with a sharp chisel.

The crow's nest. Cut the 4"-by-4" block from 7/8" stock. Bore a 1" hole in the center and cut the mortise square. Drill the 3/8" pin holes for the dowels and round the edge. Now, using the mortise, mark the round tenon on the post and cut it square. Slot the tenon and cut the wedge so that it fits snugly.

Finally, cut the cleats and drill all holes. Since bird's-eye is an especially tough hardwood, drill the right-size body and pilot holes. (Rubbing a little soap or wax on the threads makes turning in the screws easier.)

Assembly. Make a trial assembly without glue to check the table for plumb and level. With the table on a level surface, check the post with a framing square and the top (in the horizontal position) with a level.

The brass tilt-table catch can be fitted and installed at this time. The one used here is number 48 (\$2.95) from Horton Brasses, Box 95, Brooks Hill Rd., Cromwell, Conn. 06416.

Do the gluing in two steps. First, glue the dowels in their mating holes in the crow's nest. Secure one cleat to the top, position the crow's nest, and fasten the second cleat. (Note: Dowels are not glued to the cleats.) The legs can be glued to the post at this time. Later, glue the crow's nest to the post, fit the mortise-and-tenon, apply glue, and drive the wedge in. When dry, cut the wedge flush with the tenon.

The table shown was stained with Minwax Ipswich Pine, then rubbed with linseed oil. Since it was to be used occasionally to serve snacks, final finish was a coat of polyurethane varnish for durability. If you follow the same procedure, allow the oil (which is used generously) to dry for at least 72 hours before applying the varnish. After two or three weeks of curing, rub the surface to a soft luster with Butcher's wax.

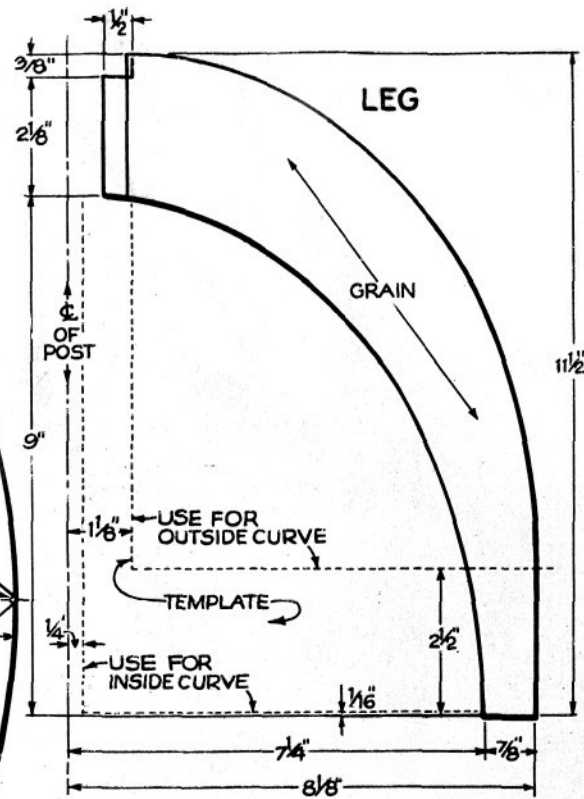
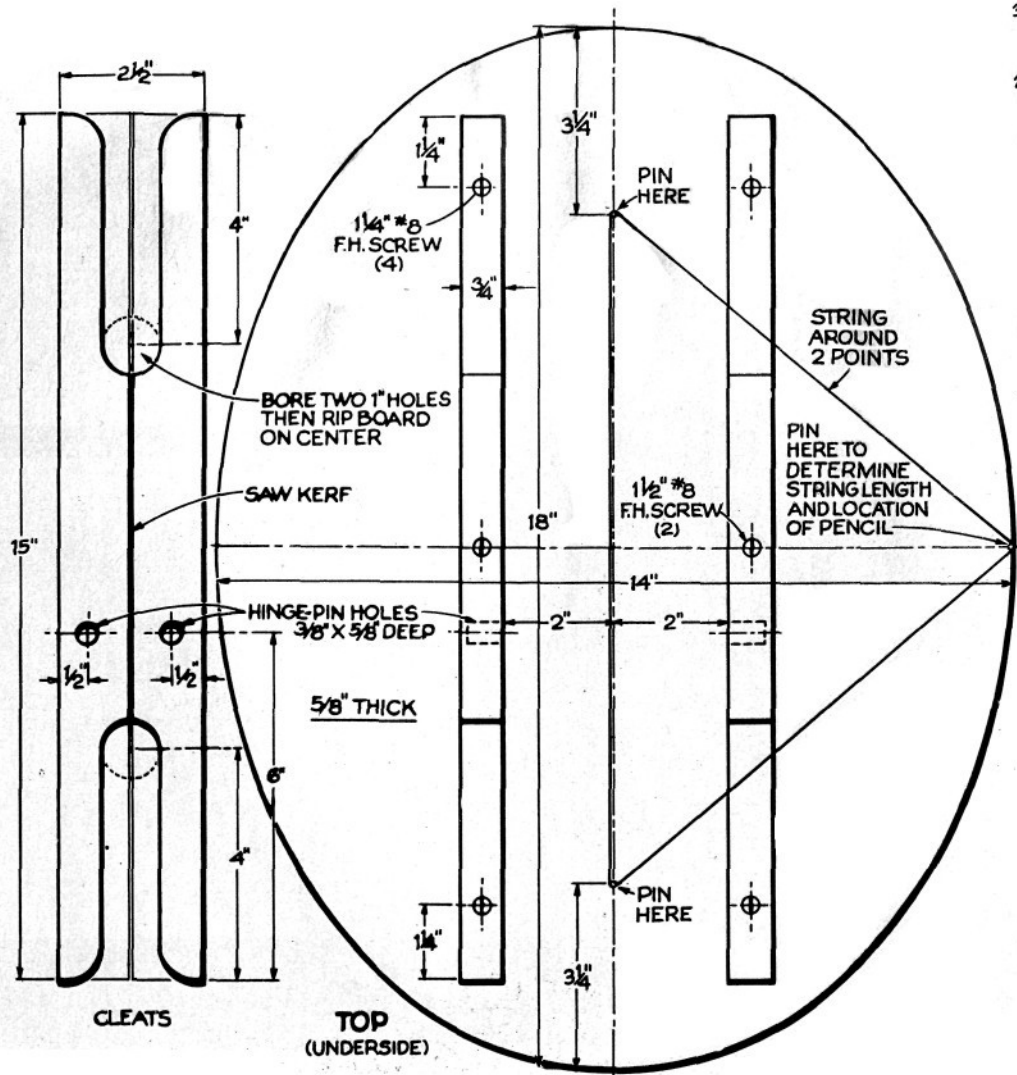

PS LIE-FLAT BLUEPRINT
TILT-TOP TABLE

