

WILDFLOWER'S NOTES
SPRING 2008

ODDS AND ENDS

MAKE A FOOT POWER WHEELIE

Some years back, out of recycled materials and hardware built a "WHEELIE" to utilize foot power to mechanically rotate a homebuilt alternator for a survival demo. The "WHEELIE" took only several days to build from scratch.



The homemade alternator, built with salvaged microwave magnets and cooling fan coils used LED's to rectify the current, produced about 12 VDC at 1 AMP. This was constructed from a drawing within six days.

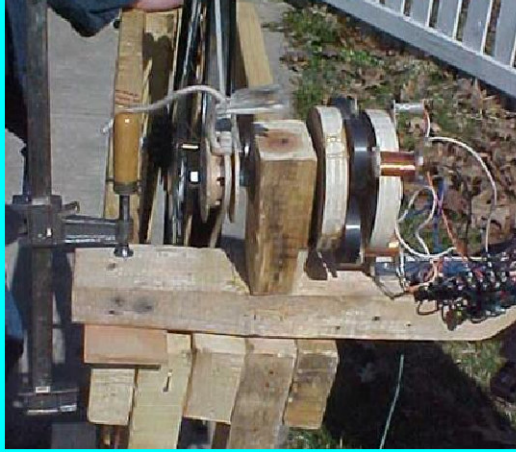

The objective at the time was to demonstrate that “homemade power” could in a post aftermath could be built from salvaged materials available in many areas. The alternator was just a perfect demo to show the main feature, a foot power “WHEELIE” that could supply mechanical power for pumps, food grinders, cable linked rotary tool-bits.

This is simply notes and descriptions that can help you brew up your own freeware version of my “wheelie” . Made from pallet wood “2 x 4’s”, this could have been built even from lumberyard prime wood, metal, or plastic wood. But hey pallets were free to find and salvage.

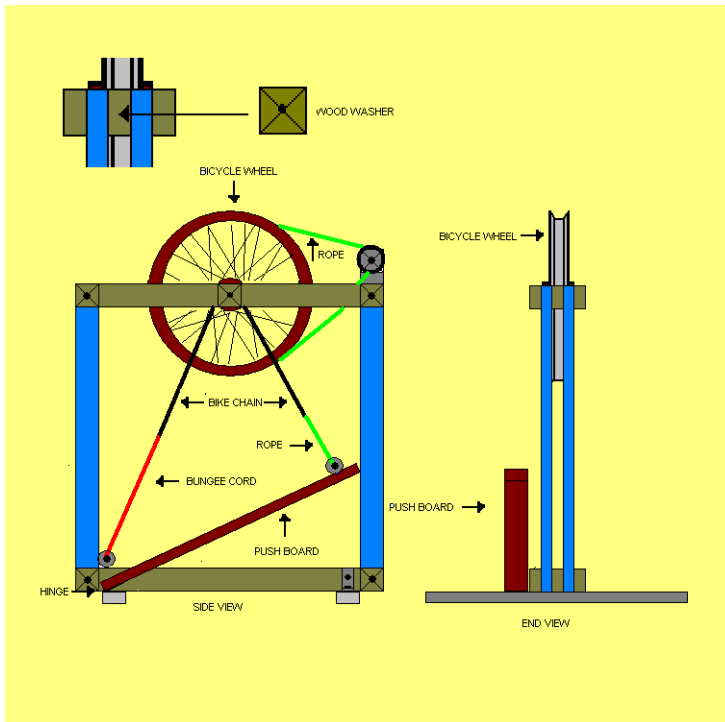

The average length of pallet “2 x 4’s” average about 44 inches each, took three pallets to yield 12 of these boards needed. 8 of these were “center drilled” at each end with a 3/8” wood bit and drill press. 2 of these 8 were measured and drilled in the middle centers with same bit. (These two wood sections for the bicycle wheel axel to be fitted into.) Two of the “2 x 4’s” were used as the bottom boards attached to the above frame with sections of slotted angle and 3/8” bolts and nuts. Finally the last two boards, one became the pedal “push board”, the other was measured, drilled and cut into “2 x 4 x 4’s” wood washers. These are used in the middle of each corner of the top frame. All the frame 3/8” bolts, nuts and washers used in this project were salvaged from a local contraction bin. Funny how much unused hardware gets dumped after a job by the contractors.

The push (pedal) board is attached to one of the bottom boards with a salvaged hinge from a garage door. The other end (not shown) has a side 3/8” screw ring to attach the chain cord to.

From a curbside source, acquired a 26” “mountain type” bicycle which was in good condition, yet thrown out for what reason? First off, salvaged the rear wheel and chain, then the front wheel and various cables for the junk-box. (The frame was later cut up for the metal recycler bin downtown.) this rear bicycle wheel was important because it didn’t have an internal drum brake.

So I assembled the frame, starting at the bottom, then the sides, and finally the top, taking care to assemble will holding the wheel hub bolt into the two middle top holes. Because the wheel was wide, had to use wood washers to space the bottom and top boards apart. (It is important that the tooth gear on the bicycle hub is on the same side as the pedal

push board.)

The bicycle chain was cut into one long length. This was positioned over the bike hub gear, one end tied to a rear elastic cord that was tied to a bottom screw ring. The other end tied to a cord that was tied to the push board top ring.

Now as you push down on the board the chain pulls the gear of the hub forward. The board is allowed to come back up, because the rear elastic cord pulls the chain and board back. Because the hub drum has no brake, the bicycle wheel can continue rotating forward, as you move your leg up and down pumping the pedal board. This here is the "WHEELIE", a foot powered source of mechanical energy which with a belt in the wheel rim to a pulley driven generator, pump, or any other need.

The homemade alternator, had used a rope as the belt, tension adjusted by hand, then by moving the alternator back a bit and re-clamping it to the top frame. Crude, yes; but it worked well that day.

The elastic cord, could have used a section of inner tube as a substitute. But hey, this whole thing was designed and put together within a week. Could had used other materials, hardware, hinge, whatever. Feel free to experiment with your own version. All my projects are "FREEWARE" or "open source", free to be duplicated by anybody, anywhere or anytime. If you decide to build it for a trade item, do take care to "idiot proof" as best you can.

Now as for the homemade alternator, it too was built with salvaged wood, parts, hardware, and even the magnets and coils. Basically used a bicycle hub, mounted in a "2 x 4", one end to a homemade wood pulley sheave, the other side held the rotating disk with alternate "NSNS" magnets.

How to mount a bicycle hub in wood? See the next illustration(s) please.

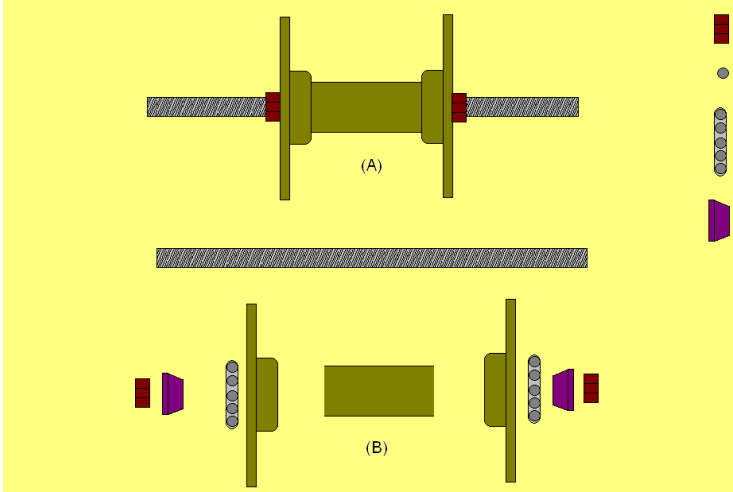

(A) COMPLETE HUB FROM A FRONT BICYCLE WHEEL

(B) DIASSEMBELED, THE HUB CENTER IS CUT OUT AND REMOVED FROM THE HUB.

(NOTE# A Dremel re-in forced metal cutting disk was used instead of a hacksaw)

(C) IN A "2 x 4" FIRST DRILL A HOLE THE DIAMETER OF HUB CENTER, THEN WITH A ROUTER CUT OUT AROUND THE HOLE TO ACCOMADATE THE HUB FLANGE BEARING CUP. FROM THE TOP OF THE WOOD, DRILL A 1/8" DIAMETER HOLE FROM TOP ENTER DOWN INTO THE CENTER HOLE. ONE COULD THEN (OPTIONAL) SAND AND SPAR VARISH HOLES.

(D) SHOWS A REASSEMBELED BICYCLE HUB EMLACED INTO THE WOOD HOLE. BEFORE ASSEMBLY, GOOD TO SOAK BEARINGS IN OIL, AND THE INSIDE HOLE WITH SOME WHEEL GREASE OR PETROLEUM JELLY BEFORE ASSEMBLY.

LATER ON, AFTER A FEW HOURS USE, OIL THE ASSEMBLY VIA THE TOP OIL HOLE. GOOD TO REPEAT EVERY WEEK OF USE.

(NOTE# used filtered motor oil can be used)

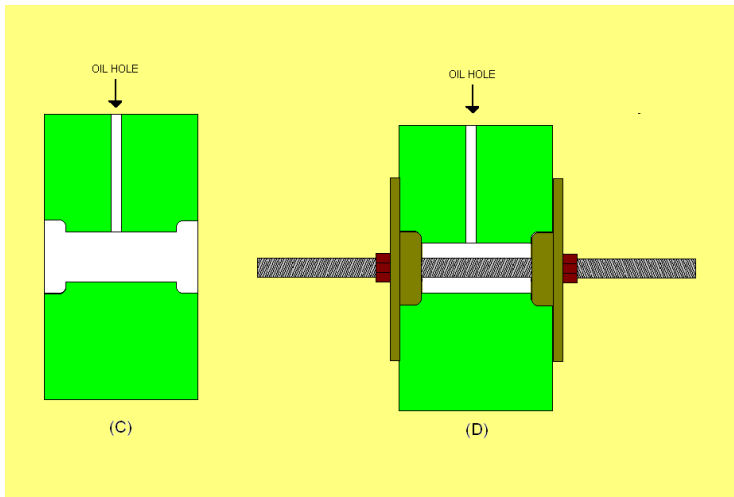

SALVAGING PALLET WOOD

In most cases, people collect wood pallets just to cut up and burn for heat. However, there are others whom will use wood pallets as a source of “free wood” for constructing furniture, workbenches, wood items, and even sheds and houses.

All pallet wood is generally rough cut and powered nailed together. Sources of wood may include pine, spruce, ash, oak, chestnut or even exotic woods including teak and redwood. The “2 x 4 ‘s” and “4 x 4’ s” are cut to true sizes versus the finished versions sold at a lumber outlet.

To take apart a pallet, good to wear gloves as splinters will always be present. Most times a pallet may be knocked apart with a 2 or 5 pound sledge, the nails be “tapped out” and then pulled with a nail remover crowbar. Salvaged nails can be straighten and reused. After separation, the wood pieces should be set aside in a stack (with the layers separated by short wood sections) inside the building to dry out at least for a month before using. To salvage plywood off a pallet, grind off the top nail heads, then with hammer taps and prying with a crowbar, separate the plywood from the runners. This way, you avoid damaging the salvaged plywood. As for removing the headless nails from the runners, a 10WR VISE-GRIP Pliers works best in gripping and removal.

In using the pallet wood, one should pre-drill before using nails or screws. For workbenches to sheds, am preferable to using lag screws or bolts to assemble such. In cutting a bow saw or an electric “all saw” is preferable. If assembled project be kept outside, two coats of spar varnish or oil based “porch and deck “ enamel will protect the wood for many years of use.

Another source of usable “free wood” are shipping crates. However most are power stapled together , requiring care in hammering apart. Small pry bars and vise-grips are helpful too. Usually constructed from finished wood, sections of thin plywood, or even compsite wood; sometimes also with salvageable metal or plastic hardware and fittings.

In any case, best times are usually Sundays to pick up pallets thrown out behind stores. One should be aware that many places including WAL_MARTS and HOME DEPO will not let you retrieve discarded pallets. Second, Pallets that are painted or made from plastic or combo there of, is store property usually waiting for official pickup, so leave them alone too! And in winter, you may meet others whom might be hostile because they want the pallets for firewood. I usually collect during the warmer months, to separate and store for later use.

NOTE# pallets from Asian sources may be treated with pesticide to prevent importation of wood pests and diseases.

HOMEMADE WOOD LYE

When your stock of commercial canned lye runs out, you can still obtain a lye from wood ash for making soap or bio-diesel.

Take a five gallon plastic bucket and drill a few dozen 1/8" holes in the bottom. Line the inside bottom with a section of rag cloth, put inside on top of the cloth, cold white wood ash up to 2/3 of bucket height, then cover with another piece of cloth over the ash. Put the bucket over another five gallon plastic bucket with two pieces of wood as shown in illustration. Pour slowly hot water over the top cloth, no more than what can be soaked down, at least four gallons max is collected in the bottom bucket.

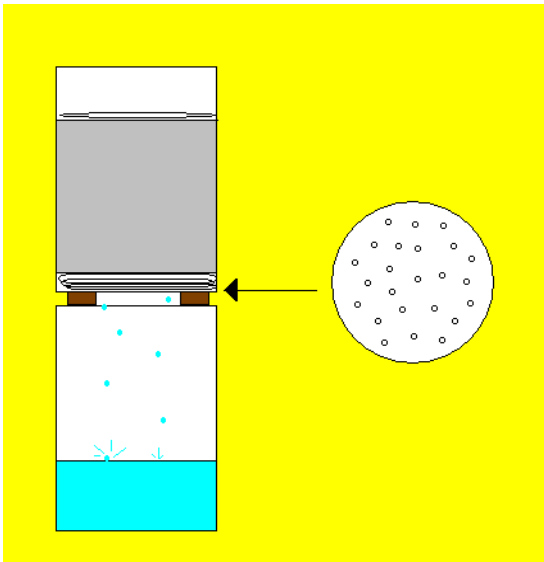

In a steel pot or pail (never use aluminum) slow boil the lye water down to a concentrated liquid which can be bottled in glass mason jars with plastic lids for later use, or the concentrate is slowly heated and evaporated into dry crystal lye using a steel pan. Dry lye should be stored only in a glass mason jar with plastic lid preferable. Do label jars clearly

as to contents stored! Wood lye will vary from wood to wood used, the lye water should be checked with a test hydrometer for its specific gravity. Old-timers used a potato scrap. If it floated, the lye water was “good to use”.

In any case handling wood or store lye should be done with rubber dishpan gloves, protective eye goggles and apron, in a well ventilated area. Spilled accidentally on skin, immediately rinse with lots of water fast, discarding contaminated clothing as it washed too. So take care please!

GOT NO VACUUM GAUGE?

Try this vacuum “gauge” made from a quart mason glass jar.

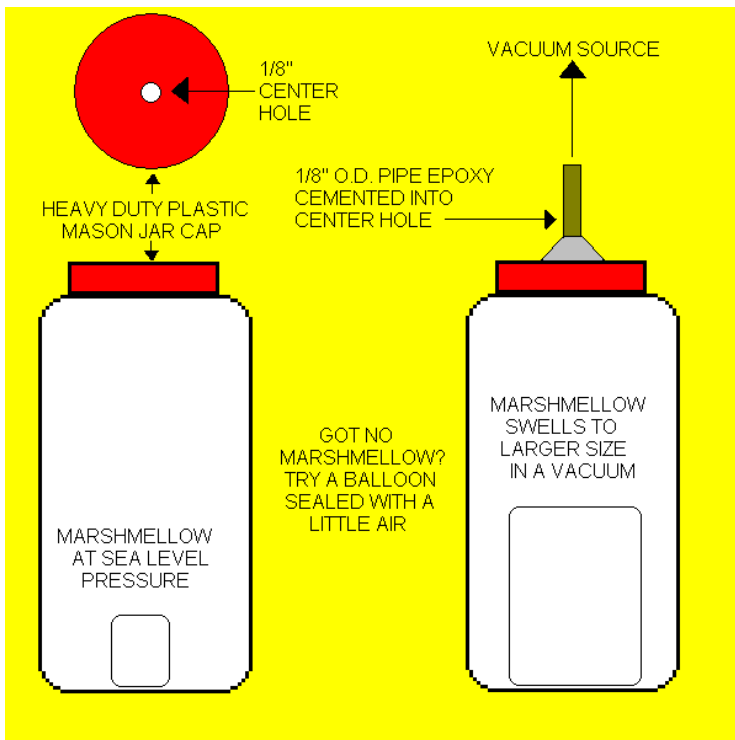

USES FOR KITTY LITTER JUGS

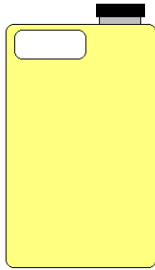

REUSE TO STORE WATER, WASTE MOTOR OIL, SAND, SAWDUST, CHARCOAL, COAL BITS, DRIED GRAINS OR BEANS, SALT, AND PAINT BALLS.

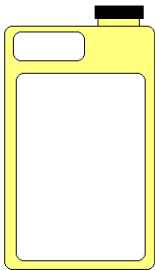

CUT A HOLE ON ONE SIDE. USE IT AS A BASIN TO CATCH DRIPPING WATER OR MOTOROIL. MAKES A NICE WASH BASIN. FILL WITH DIRT AND PLANT FLOWERS

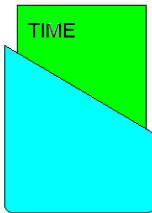

MAKE A DIAGONAL CUT, USE IT TO STORE MAGAZINES, COMIX, OR THIN BOOKS ON SHELF



CUT INTO A STORAGE TRAY TO HOLD SHORT PIECES OF WOOD, METAL, OR PLASTIC LABEL END WITH MARKER PEN



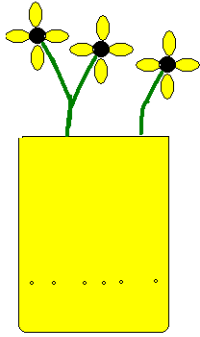

CUT OFF TOP. PUNCH HOLES 3 TO 4 INCHES ABOVE BOTTOM. ADD A FEW INCHES OF GRAVEL THEN DIRT. GO PLANT A FEW FLOWERS

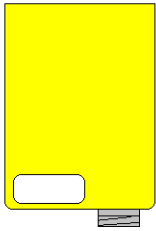

CUT OFF BOTTOM AND USE IT AS A LARGE FUNNEL FOR LIQUIDS OR DRY MATERIALS