



A simple-to-make, hot-burning, backcountry stove

The Super Cat Alcohol Stove

By Jim Wood

Originally published January 29, 2005

Major update November 18, 2008

Last revised November 18, 2008

[Printable PDF version available here \(1.8mb\)](#)

[Submit or read comments about this article here](#)

[Home](#)

[Feedback forum](#)

Originally developed in early 2004, the Super Cat alcohol stove was first shared with the online backpacking community in January, 2005. Since then, it's become one of the most popular do-it-yourself alcohol stoves among hikers worldwide for probably two reasons: it works exceptionally well and it's very easy to make.

This update to the [original article](#) is intended to incorporate many of the design ideas that Super Cat users have contributed over the years, as well as to expand the scope to include new information about build techniques, fuels, windscreens, stands and other accessories.

It's also being published concurrently with a new article entitled "[The Fire Bucket Stove System](#)", which introduces a companion product that can serve either as a high performance windscreen for the Super Cat (and most other alcohol heaters), or a stand-alone stove that is capable of burning wood and solid fuel tablets—all at a weight (in its lightest implementations) of about two ounces.

When used together, the Super Cat and Fire Bucket form an efficient, lightweight, integrated stove system that's easy to make and fun to operate.

You can navigate directly to each chapter using the links below.

<p>Background</p> <p>Alcohol Stove Designs</p> <p>Disclaimers and Safety Notes</p> <p>Materials</p> <p>Tools</p>	<p>Super Cat Build Instructions</p> <p>Super Cat Fuels</p> <p>Starting and Using the Stove</p> <p>Accessories</p> <p>Resources</p>
--	--

Background

More than a century after the venerable Svea kerosene stove first went into production, one might reasonably wonder why backcountry stoves, like so many other mature products, haven't coalesced around one or two successful design technologies.

Instead, today's backpackers still burn white gas, kerosene, diesel, automotive gas, jet fuel, propane, solid fuel tablets, butane/propane mixes, wood, paraffin, mineral spirits, vegetable oils, methanol, ethanol, and isopropyl alcohol in a huge variety of stove types.

So why still so many choices? I guess simply because no one has yet been able to come up with an all-in-one design that can meet the wide range of environmental, fuel availability, weight, cooking, and safety requirements of today's hikers.

The future may belong to an atomic fusion stove that weighs two ounces and can run for a hundred years on one gram of fuel, but in the meantime, the top-mounted (iso)butane/propane canister stove probably comes closest to meeting the needs of most of today's three-season backpackers, particularly those who trek in Europe and North America.

Ultralight models, often equipped with piezoelectric lighters, are made by MSR, Primus, Gaz, Snow Peak, Brunton, Optimus, Coleman and others, and are convenient, dependable, quiet, efficient, and though hot burning, can also simmer well. In addition, analysis has shown that even for gram-counting long-distance hikers, these stoves compare favorably with other types of stoves from a weight-to-performance point of view.

Nonetheless, these stoves are not perfect. My own biggest complaint is that the fuel canisters themselves are not refillable by the user, which means that it's often difficult carry just the amount of fuel that you think you'll need for a given outing.

In addition, compatible canisters are sometimes difficult to find outside the U.S. or when re-supplying on long hikes (canisters can't be transported on commercial airliners). These stoves also typically perform poorly in cold weather and can be difficult to use with conventional windscreens (although the [KiteScreen](#) offers a great solution to this last problem).

Alcohol Stoves

Alcohol stoves are one of the most popular alternatives to canister stoves, especially for long-distance hikers, perhaps because they solve one key problem: fuel availability. Alcohol stoves can burn ethanol or methanol (and combinations thereof), or in a pinch, even isopropyl alcohol, which means that fuels at re-supply points are generally fairly easy to find at liquor, hardware, automotive or variety stores.

Alcohol stoves also allow hikers to carry just the amount of fuel needed for a given outing, are super-quiet in operation, are usually very simple in design (no fuel jets to clog or other components to fail in the field), and are usually extremely light weight. Many green-spirited backpackers also like alcohol stoves because they use a renewable fuel source, unlike the majority of stoves now in use that burn fossil fuels (although alcohol stoves still emit carbon dioxide, a greenhouse gas).

On the flip side, alcohol stoves present certain safety hazards, including a flame that's nearly invisible in sunlight (which means that it's sometimes difficult to detect when the stove is operating) and the use of an open fuel tank that can spill flaming alcohol on you and your surroundings if tipped over.

These stoves are typically also more wind-sensitive than other types—and as a double whammy—use their fuel much more quickly than do fuel-metered stoves under windy conditions, at least if not properly protected. And while they excel at boiling water, alcohol stoves are typically difficult to control for simmering.

All designs of which I'm aware must be also re-filled after every use. This single-shot-of-fuel per use operation means that it's often tricky to gage how much alcohol to add to your stove for any given cooking operation. As a result, backcountry cooks usually either run out of fuel before finishing, or end up with excess fuel that frequently burns wastefully away until it's finally consumed (although some of

the accessories and techniques described below can reduce this waste).

Likewise, the energy content of alcohol is considerably less than comparable petroleum-based fuels (typically about half), which means that significantly more fuel must be carried. The good news here is that alcohol fuels are safer to handle, can be transported in ordinary plastic bottles, and can be extinguished with water in an emergency.

JIM'S STRATEGY

Despite their disadvantages, I still like alcohol stoves. Sometimes I use one as a primary heater and sometimes as a backup or "fill-in" for my canister stove. Carrying an alcohol stove, which weighs almost nothing by itself, often allows me to avoid carrying a second weighty canister if I'm concerned about not having quite enough fuel. I can include just the right amount of alcohol to supplement the main butane/propane supply for the trip.

For this type of use, a backup stove doesn't need to be a full-featured replacement. All it really needs to do well is boil water in a reasonable amount of time, which also allows it serve as a second burner in the preparation of some meals.

I also now usually carry the Fire Bucket Stove System which can work as a windscreen for either the Super Cat or canister stove (see the [Fire Bucket article](#) for details), or in a pinch, burn wood if I run out of other types of fuel.

Alcohol Stove Designs

There are dozens of do-it-yourself alcohol stoves currently described in various spots around the Internet. Rather than duplicate information that's already available, I would instead refer you to the most complete backpacking stove site that I've found thus far: the [Zen Stove site](#).

NON-PRESSURIZED vs PRESSURIZED

For purposes of classification, however, I will note that alcohol stove designs generally fall into one of two categories: non-pressurized and pressurized.

Non-pressurized models work by simply housing an open flame that's created by burning expanding alcohol gases. These gases exist anytime that liquid alcohol is warm enough to evaporate, where the warmer the liquid, the faster the rate of evaporation. Examples include Roy Robinson's Cat Stove and the Robert Crowley Plumber Stove.

Pressurized models restrict the expansion of this gas in some manner to create gas "jets" that are said to burn a little hotter than do non-pressurized flames. Since I've done limited testing myself, I can't say for sure that it really makes any difference, but in either case, the Super Cat would be classified as a pressurized design. Also, because of slightly higher flame velocities, pressurized models are probably tend to be a bit less wind-sensitive.

While I'm at it, I'll also note that the term "pressurized" may also be a bit overstated, since the amount of back-pressure created by restricting the gas flow is very small—just enough, in fact, to force the expanding gas out through a series of burner holes. It's nothing like the pressure, for example, that's created by manually pumping an MSR white gas fuel bottle.

SIMPLICITY OF DESIGN

Probably the most significant thing that sets the Super Cat apart from other pressurized stoves such as Scott Henderson's Pepsi-G, the Anti-Gravity Gear Tin Man, or the Brasslite stoves, is the simplicity of design.

Most pressurized stoves require multiple components that must be taped, epoxied, or welded together in order to create their pressure chambers. The Super Cat's pressure chamber, on the other hand, is created simply by placing a pot on top of the stove, thereby blocking the ability of the expanding gas to

escape through the top, forcing the flames out through the side vents.

The Super Cat design is also simpler than most others because it doesn't require the use of a separate pot stand. The stove itself serves as both the burner element and the stand, since the pot is placed directly over the top of the stove.

Because of its uncomplicated design, the Super Cat is also very easy to build. So easy, in fact, that they're sometimes constructed on the trail (often in less than five minutes) using materials procured at re-supply stops.

Incidentally, I should note that this stove is named "Super" because it burns hotter and faster than most other alcohol stoves whose specifications I've seen. With some implementations of the Super Cat, I've consistently (under ideal, no-wind conditions) brought two cups of water from cool room temperature to a full rolling boil in under four minutes, which is among the fastest times I've noted so far, though there's really no way to guarantee the consistency of the conditions among all those who conduct these tests.

It's also called "Super" since it's super-easy to make and, at a weight of less than ¼ of an ounce, super-light weight. The "Cat" portion of the name was derived from its construction using a single, 3 ounce aluminum cat food can.

WHY THE SUPER CAT WORKS

Unfortunately, one can't punch a few holes in any old can and expect to turn it into a working pressurized stove. For starters, the can's volume needs to be just right for the alcohol vapors to pressurize in a way that allows them to expand through the side vent holes after lighting.

If the internal space is too large, the flame will simply be extinguished when the pot is lowered into place. Alternatively, if it's too small, the same thing will probably happen, but even if it manages to pressurize, the stove's fuel capacity will likely be too low to complete most cooking operations without refilling.

The diameter of the can is also important since the stove also serves as the pot stand. If the diameter is too small, the stove could become unstable when a pot is placed upon it. If the stove is too wide, the flames will probably miss most of the pot's bottom surface and some of the heat will be lost up the sides (though there are some interesting exceptions to the conventional wisdom regarding stove and pot width that are discussed below).

The material and thickness of the can's walls are also critical. In order for the stove to work properly, some of its heat must be transferred back into the open pool of alcohol to keep it boiling ("thermal feedback"). If the stove is made from a metal that's either too thick or that conducts heat poorly, the alcohol can stop boiling, killing the flame.

Conversely, if the sidewalls are too thin, then the stove probably won't support the weight of a pot filled with two to four cups of water (which might weigh two pounds or more) and could collapse when heated to operating temperature.

SO HERE'S THE MAGIC

It turns out that the 3 ounce aluminum can that's recommended for Super Cat use is just about perfect for this task.

The volume is such that the alcohol vapors pressurize properly under almost all altitude, temperature and other operating conditions. It's also large enough that, depending on hole configuration, it will hold up to 2 fluid ounces of fuel, which is usually more than enough for most cooking chores. Likewise, the can's diameter easily supports most commonly used pot sizes while maintaining a high degree of efficiency.

The aluminum walls are likewise thin enough to efficiently conduct heat to the alcohol pool to keep it boiling, but are also thick enough to safely support the weight of a full pot of water (at least of the size range most likely to be used).

Over the years, I've experimented a variety of other cans types that have been larger, smaller, and constructed from metals such as steel and brass, and I have yet to find anything that works as well as

the 3 ounce aluminum can.

the question of pot width

One interesting thing I've learned from my development experiences is that the conventional wisdom about side-burner stoves and pot width is not necessarily correct. Many hikers believe that alcohol stoves like the Super Cat only work well with wide-bottom pots under the theory that narrow pots allow too much of the stove's heat to flow up the sides of the vessel, thereby significantly reducing efficiency. In truth, it's not that simple.

Somewhat to my amazement, the fastest boil times I've ever observed with the Super Cat have been with tall, narrow cook pots. More specifically, I'm referring to those that are constructed from 24 or 25 ounce aluminum beer cans sold by Heineken, Fosters and others. These cans, which are quite popular with ultralight backpackers, have bases that are only about 3¼ inches wide, compared with a pot like the Snow Peak Trek 1400 (my personal favorite) whose base is a bit over 5 inches wide.

With these beer can pots, I consistently clock boils times for two cups of cool, room temperature water at under 4 minutes with the Super Cat, while the best I've seen with the much wider Snow Peak 1400 is about 4½ minutes under the same conditions.



Beer can cook pots with Super Cat stoves (+)

The Foster's can on the left includes a silicone lip guard from [Ultralight Outfitters](#)

Much of the reason for the speedier beer can boil times is related, of course, to the material from which these vessels are made. The very thin aluminum walls of the cans conduct heat more efficiently than thicker titanium walls of the Snow Peak pot, partly offsetting the effects of their less-than-optimal shapes. And to be fair, in a titanium-to-titanium comparison, the Snow Peak 600 mug, whose base is about the same with as the beer can pots, requires 15% to 20% more time to boil two cups of water than does the wider Snow Peak 1400, whose walls are of about the same thickness.



**Snow Peak 1400 (L) and Snow Peak 600 (R)
with Super Cat stoves (+)**

But my point here is even when using fairly narrow pots, a significant amount of energy transfer occurs when a stove's flame wraps around the pot bottom and travels up the sides. Accordingly, I think you'll be happy with the performance with the standard 3 ounce can when used with just about any reasonably-sized cook pot.

Just to be sure, I've constructed stoves from narrower aluminum cans like those used for Red Bull energy drinks. Those cans are about 2 inches in diameter versus 2.4 inches for aluminum pet food cans (i.e., are about 83% as wide) and I have seen no significant difference in boil times.



Red Bull sized stove with Snow Peak 600 titanium mug (+)

Disclaimers and Safety Notes

Disclaimers

Before proceeding, I should point out that I am not a chemist, nor an expert in stove technology. I am just a backpacker who struck upon something interesting a few years ago that I felt was worth sharing with my fellow hikers.

If you decide to build your own Super Cat, you must assume all risks. I obviously can't guarantee your safety nor indemnify you against accidents.

While there are a number of hazards associated with any backpacking stove, an alcohol stove like the Super Cat probably has more than its fair share, as I discuss in the next section. That said, as long as you're careful, building alcohol stoves can be safe and a lot of fun, perhaps even bordering on addictive for some.

I should also mention that when researching existing stoves prior to developing the Super Cat, I found many clever and well-tested designs available. Nonetheless, I had an idea for a type of stove that didn't seem to be represented by any of the models I read about, though it's certainly possible that someone has employed this design before. If so, I apologize for the lack of attribution, but note that I did arrive independently at all of my conclusions.

Safety Notes

Experienced outdoors people already understand that any backcountry stove is potentially dangerous and should be handled with great care, especially when operated in the vicinity of a tent or tarp. Alcohol stoves like the Super Cat, however, are probably even more hazardous than some other types for reasons that are discussed below.

CARBON MONOXIDE

All backcountry stoves can emit fair amounts of carbon monoxide (CO) which can be deadly if concentrated in closed spaces. The best review I've seen of hiking stoves and CO was prepared by Roger Caffin, an expert who writes for backpackinglight.com.

In Part 4 of his excellent series of research articles, Roger studied the emissions of ten commercial alcohol stoves and concluded that:

"...each of these alcohol stoves emits more CO than the best canister stoves... all should be considered extremely dangerous in any confined space."

To my knowledge, the Super Cat has never been tested for CO emissions, a task that requires a unique laboratory setup. I have no reason to believe, however, that the carbon monoxide generated by the Super Cat would be much different from any of the stoves Roger tested. Accordingly, you need to be especially careful when operating the Super Cat indoors or inside a tent vestibule. Without plenty of fresh air ventilation, carbon monoxide can kill you.

By the way, Roger's article [can be found here](#). To read the full text, you'll need to be a BPL online subscriber (currently \$24.99 per year); otherwise, only the abstract will be available.

FIRE HAZARDS

Because fuel is burned in an open container, an alcohol stove like the Super Cat can present a significant fire hazard. Unless the stove is anchored to the ground or to a windscreen like the [Fire Bucket](#), it's fairly easy for the stove to tip or blow over during operation. And as you might imagine, spilling flaming alcohol on you and your gear is a great way to ruin your day.

Likewise, when using the Super Cat, make sure that all combustibles are positioned well away from

the vicinity of the stove and that there's a water source available if things go seriously wrong. Unlike grease or petroleum fires, which are often spread when water is applied, alcohol fires can usually be safely doused by drowning. Other less drastic methods of stopping the Super Cat, such as depriving it of oxygen, are discussed below.

Fires can sometimes also start with alcohol stoves because they operate so quietly and burn with a flame that's nearly invisible in daylight. You need to be especially careful to keep flammables (like synthetic clothing) away from your stove if there's any chance it could be running. Probably the best method to confirm operation if you're uncertain is to place your hand near the stove or its windscreen to feel for warmth.

Petroleum-Based Fuels

I would also counsel you not to use the Super Cat, or any alcohol stove, with petroleum-based fuels such as automotive gasoline, kerosene or white gas (Coleman fuel). With lower boiling points, these fuels are more volatile than most alcohols and are dangerous to burn in open containers. Because they're heavier than air, petroleum vapors can pool in low-lying areas and explode when exposed to flame.

And in case you're tempted to try a higher energy content fuel (like white gas) in the Super Cat, you should also know that I've already tried many of them and they just plain don't work. They typically burn with a low-temperature, yellowish, sooty flame that won't pressure in this stove. These liquid fuels only work effectively when vaporized under fairly high pressures and temperatures in stoves like the MSR WhisperLite.

Silnylon Shelters

Finally, a special reminder to ultralighters who might be using silnylon tarps or tents. Standard silnylon (i.e., the kind that's not additionally treated with polyurethane) is not a fire-retardant fabric and will burn fairly quickly if exposed to a flame.

FUEL TOXICITY

When compared with (iso)butane/propane canister stoves, liquid fuel stoves can present the additional hazard of direct exposure to toxic chemicals.

Denatured alcohol and yellow Heet are the most commonly burned fuels in alcohol stoves, at least here in the United States. While a more detailed discussion of these substances is included in the "[Super Cat Fuels](#)" section below, I'll just concentrate here on the potentially harmful effects of one of the key ingredients in these fuels: Methanol.

Most denatured alcohols contain some amount of methanol, which is a toxic form of alcohol that's intentionally added to ethanol to render it undrinkable. Methanol, which is used in a wide range of applications, is also known as methyl alcohol, wood alcohol, carbinol, wood naphtha and wood spirits.

Poisoning Hazards

The problem with methanol is that it's quite toxic to humans when ingested, inhaled, or absorbed through the skin. Historically, the most common form of methanol poisoning has occurred orally. Consumed in sufficient quantities, methanol can quickly lead to blindness and death, primarily through the formation of formaldehyde in the liver when the substance is metabolized inside the body.

This form of poisoning is perhaps best known in connection with drinking liquor (such as moonshine) that's produced under unsafe conditions. Unless properly distilled, methanol can be generated as a byproduct of whiskey production. Most backpackers probably don't need to worry about accidentally drinking methanol, however. Instead, exposure is more likely to occur through inhalation or absorption through the skin.

After plenty of Internet research, it's still not clear to me at what exposure levels methanol becomes dangerous through these two mechanisms. Perhaps the studies have been done, but I've not found them. There is universal agreement, however, that the risks are real. As noted in the [Wikipedia methanol article](#):

"...Dangerous doses will build up if a person is regularly exposed to vapors or handles liquid without skin protection."

The truth may be that nobody knows for sure at what point inhalation and skin exposure becomes unsafe. I would simply offer the following obvious advice to any backpacker who might elect to use methanol-based fuels:

- Avoid breathing alcohol vapors, whether burned or unburned.
- Use a fuel bottle and filling system that minimizes the chance that you'll spill alcohol on your hands or clothing. If spillage does occur, promptly wash the affected surfaces.
- Be especially careful not to allow alcohol fuel to leak into your water or food supply while you're on the trail. Most backpackers carry their fuel bottles in an external pack pocket in such a way so that if leakage were to happen, there would be little chance of contaminating food or water.

I will finally note that denatured alcohol products often contain other toxic ingredients besides methanol. Methyl isobutyl ketone, acetone, ethyl acetate, rubber solvent and other hydrocarbons are frequently added to ethanol as denaturants, each of which is potentially dangerous. Because their concentrations are usually small, however, these other ingredients may not represent quite the same magnitude of risk as does methanol.

SUPER CAT-SPECIFIC ISSUES

In addition to the general risks described above, the Super Cat presents a few unique challenges that are discussed in the "[Starting and Using the Stove](#)" section below. Fortunately, all of these Super Cat-specific risks can be easily minimized or eliminated by using either the techniques or accessories that are likewise discussed in that section.

LIVING HAPPILY IN SPITE OF THE ODDS

While I feel it's important to inform you about potential dangers, I hope I haven't discouraged you from building and using a Super Cat.

The truth is that alcohol-based stoves are generally accepted as safe by most knowledgeable backpackers, as long as the user exercises a fair measure of common sense. I've been working with and testing these stoves for many years without serious incident and accordingly, would encourage you to give the Super Cat a try.

Materials

CAN SELECTION

At the core of the Super Cat project, of course, is an empty, clean aluminum can. The 3 ounce size that's widely found at most grocery stores and used for products such as cat food and potted meat sandwich spreads is probably the best all-around choice for the reasons discussed above. Examples of this type of can are shown below.



Samples of products packaged in 3 ounce aluminum cans (+)

You'll find that even among similar can types, there will be some variations in dimensions and weights. For example, the Hormel potted meat can shown above is slightly taller than the Fancy Feast cat food can, even though both contain 3 ounces of product. Most of these minor variances will have little or no impact on stove performance, however.

Aluminum vs. Steel

One factor that will have a major impact on stove performance is the metal from which the can is stamped. It turns out that not all 3 ounce food cans that are made from aluminum. Some, such as those shown below, are constructed from steel.



Samples of 3 ounce steel cans (+)

While some of these steel cans are perhaps useable for Super Cat stoves, there are some noteworthy issues:

1. A 3 ounce steel can will probably weigh about $\frac{3}{4}$ ounce, or about three times as much as a comparable aluminum can.
2. Although perhaps more durable than similar aluminum cans, steel cans are more difficult with which to work. Most standard office hole punches won't be able to penetrate the sidewalls, so you'll either need to drill or use a sheet metal ("Whitney") punch such as that described in

the "Tools" section below.

3. The greater thermal inertia of steel stoves leads to longer cooling times, which extends the wait before they can be moved, packed or safely refilled after use.
4. The thicker walls of steel cans don't conduct heat as efficiently as the thinner aluminum, which creates very different burn characteristics. For example, the thermal feedback mechanism (discussed above) that's necessary to start and keep the pool of alcohol boiling takes much longer to work. Likewise, steel stoves tends to run cooler, which contributes to longer boil times.

The performance results from tests conducted recently in a head-to-head comparison of aluminum and steel stoves is shown below. Both stoves were fueled with one fluid ounce of SLX denatured alcohol and used to heat two cups of cool room temperature water in a Snow Peak Trek 1400 titanium cook pot to a rolling boil. The fuel in both stoves was also ignited without external priming mechanisms (such as a priming pan).

	Aluminum stove	Steel stove
Prime time *	25 sec	2 min
Time to rolling boil (incl prime time)	4 min, 30 sec	8 min, 45 sec
Total stove burn time (incl prime time)	6 min, 45 sec	12 min, 30 sec
* Prime time = the amount of time from ignition until the surface of the alcohol begins to boil, which also marks the point at which the cook pot can be lowered onto the stove.		

Bottom line: unless you have compelling reasons to use steel, I'd suggest sticking with aluminum. But when shopping for a suitable can, how does one distinguish between the two, since their appearances can be very similar?

One way to tell the difference is to gently press on the sidewall of the can with your thumb. Aluminum cans will flex fairly easily, while steel cans have much less "give".

Another way is to take a scale with you to the grocery store. An aluminum can that contains 3 ounces (net weight) of product will probably weigh about 3.3 ounces in total. A similar steel can will likely weigh over 4 ounces.

You can also, of course, select products that are known to be packaged in aluminum. The list below includes a few brands distributed regionally or nationally in the United States that I've verified (at least as of the date of publication) are sold in aluminum cans.

Product (3 ounce net weight size)	Manufacturer
Fancy Feast Gourmet cat foods	Nestlé Purina PetCare Co
Elegant Medleys cat foods	Nestlé Purina PetCare Co
Newman's Own Organic cat foods	Newman's Own Organics
Some Harmony Farms cat foods *	Harmony Farms Pet Products
Priority (Safeway store brand) cat foods	Safeway, Inc.
Companion (Giant Foods store brand) cat foods	Giant Food, LLC
Wegmans Gourmet (store brand) cat foods	Wegmans Food Markets, Inc

Hormel Potted Meat Food Product	Hormel Foods, LLC
Libby's Potted Meat Food Product	ConAgra Foods, Inc.
* The smaller cans are aluminum, the slightly larger cans are made from steel	

PREPARING THE CAN

Once a suitable can is obtained, you'll want to first remove the label and clean the interior. I'd also recommend that you remove the gummy label adhesive using a solvent such as Goo Gone or Goof Off (by the way, the lubricant WD-40 also does a great job of dissolving many adhesives and is probably less toxic than most other solvents).

While some of the residue will eventually burn away if you choose not to bother, the remainder will tend to stay somewhat sticky. If you build an optional stand (more below) that uses a "docking socket" to hold the stove, the residue will often melt between the stove and the holder, effectively gluing the two together. This remaining goop will also sometimes transfer to other items in your pack, so it's best to remove as much as possible.

Tools

The tools you'll need will depend on how you build your Super Cat, but are mostly quite simple. For the basic Super Cat described below, all you'll need are a flexible measuring tape and a felt tipped pen for measuring and marking ventilation hole positions, and a standard office punch for making those holes.



Simple Super Cat tools (+)

MAKING HOLES

There are many ways to create vent holes in the walls of the can, but one of the easiest (and neatest) is with a handheld office paper punch such as that shown above. Most standard punches are designed to make holes that are about ¼ inch in diameter, which is about the largest size you'll want to consider for the Super Cat. Available at most office supply stores, these punches are also inexpensive and can easily puncture the soft aluminum.

Not all of these punches are created equal, however. For example The \$0.97 punch I recently bought at Wal-Mart does not work very well, nor do any of the dollar store versions I've tried, all of which failed quickly. On the other hand, the [\\$1.29 model](#) from Staples that's shown in the photo above has performed very well.

Online craft stores are another source for quality paper punches in sizes other than ¼ inch. I actually prefer vent holes that are slightly smaller at 3/16 inch in diameter because the resultant stove flame seems to be a little less wind-sensitive than with ¼ inch holes. [Mister Art](#), for example, offers such punches in a range of sizes.

Another option is an inexpensive sheet metal punch that is much more durable than a paper punch. Also known as "Whitney" punches, they can be purchased for as little as \$20 plus shipping from online sources such as [Harbor Freight](#), that offers both [standard](#) and [deep-throated](#) models. These punch kits include multiple die sets that create holes in up to 16 or 20 gauge (depending on model) steel sheet metal in a variety of sizes. I own the standard Harbor Freight model and have found that it's ideal for building Super Cat stoves.



Sheet metal ("Whitney") punch
Shown is the deep-throated model with punches and dies

An electric drill is another obvious choice, though drilled holes tend to be a little messier than punched holes. One exception are those that are made with a variable width bit called a "Unibit" that allows for creating fairly smooth edges. Made by Irwin and Klein, these bits are available from a variety of online sources and sell for about \$20.00. I haven't tried a one myself, but some Super Cat builders have reported excellent results with Unibits.



Electric drill (+)



Unibit (+)

Finally, as described in the original Super Cat article, a sharp awl or similar tool works well and allows for easily making holes of multiple sizes. The downside is that the holes are not very pretty, but I still like this method in part because of its simplicity, but also because it can be easily improvised on the trail using a nail or pocket knife.



Alternative tools for punching holes and flattening collars (+)

If you employ the awl method, you'll probably also want a pair of pliers to flatten the ragged "collars" created by the punctures on the insides of the can. This process is described in more detail further below.

Super Cat Build Instructions

Note: There are many tools and techniques that can be used to build Super Cat stoves. The build

instructions below are designed to serve as a starting point, but I'd encourage you to experiment with alternative construction methods (some are discussed later on).

HOLE SIZES and PATTERNS

The number, sizes and positions of the vent holes will determine how well (or whether) your Super Cat works. They will control the fuel / air mixture, the burn intensity and will also affect how much weight the stove can support.

The good news is that a wide range of sizes and patterns will work to some degree, so the question is selecting the combination that will optimize the stove for a particular purpose.

Most of the time, backpackers want a stove that simply boils water quickly and efficiently. By varying the hole sizes and patterns, however, it's also possible to build a stove that burns with reduced heat output, useful perhaps for extended simmering.

Within limits, increasing the size and number of holes in the sidewall produces a stove that burns hotter, while smaller and fewer holes will cause the stove to burn cooler. The prototype stoves below show a few of the hole patterns with which I've experimented.



Stove samples show some of the hole patterns tested (+)

The first hole pattern discussed below will create a stove that burns hot and fast. The stove also burns with a mostly blue flame (with only occasional bursts of yellow) that flows smoothly from the vents without the "pumping" action that is sometimes observed when the hole pattern is not quite right.

The holes in this design are also made with a standard office paper punch and are $\frac{1}{4}$ inch in diameter. As noted above, slightly smaller holes (I like $\frac{3}{16}$ ") will produce a flame that seems a little less wind-sensitive, but $\frac{1}{4}$ inch hole punches are much more widely available and so will be used for these instructions.

I'd suggest proceeding as follows:

1. First, punch a single hole just under the top rim of the can so that its upper edge is about $\frac{1}{4}$ " below the top edge of the can
2. Next, using a felt tipped marker (Sharpies work well) and the first hole as a reference point, mark the centers of subsequent holes every $\frac{1}{2}$ inch around the can's circumference, inline with the center of the first hole. This pattern should produce a total of 15 holes. Now punch the remaining holes to complete the top row.

3. Punch a single hole in the bottom row that's equally spaced between two of the top row holes. The top of this new lower hole should be $\frac{1}{8}$ inch beneath the bottom edge of the hole above it. If positioned correctly the center of this new offset hole should also be about $\frac{1}{2}$ inch (diagonal measurement) from the centers of each of the two holes above it.
4. Finally, repeat Step 2 above, marking and punching the remaining bottom row holes spaced at $\frac{1}{2}$ inch intervals.

Note that the dimensions shown in the diagram below assume the use of a Fancy Feast gourmet cat food can and are delineated in English units (inches). If you'd prefer to work in metric units (millimeters), you can click on the link under the caption.

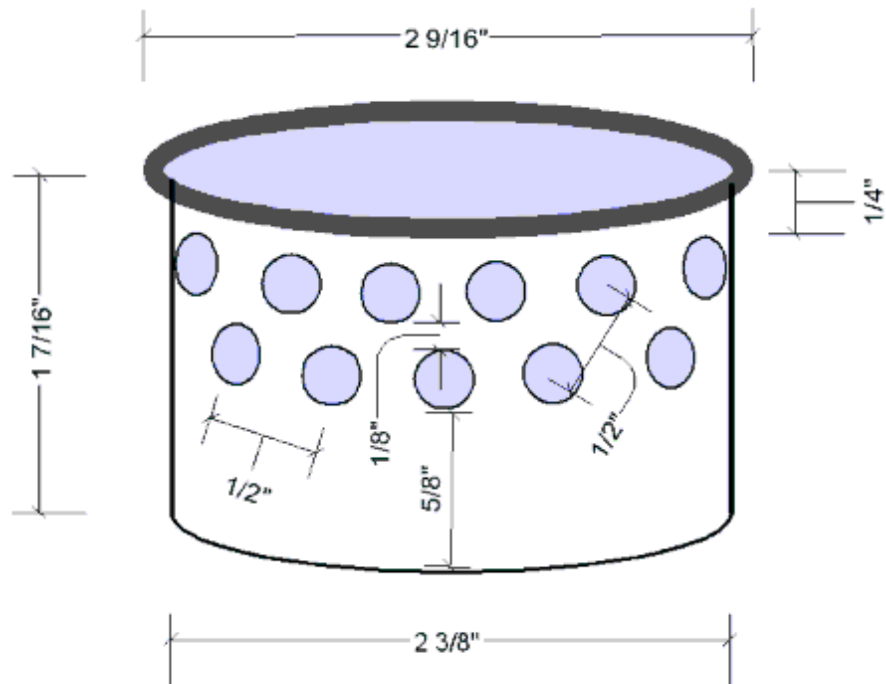

**Super Cat dimensions using a
Fancy Feast cat food can (+)**

[Click here to see dimensions in metric units](#)

When you've finished, your new Super Cat should look the the sample shown below.



**Start with a clean, empty
3 ounce aluminum can (+)**



Completed Super Cat (+)

Other Hole Creation Methods

If you make vent holes using an awl or most electric drill bits, you'll notice a ragged-edged "collar" around each hole inside the can. These collars can create turbulence in the flame jets, so it's best to flatten them in order to get the smoothest possible gas flow. Use a pair of pliers with curved pinchers (so that you don't also flatten the can rim), to gently "smash" down these edges. The photos below illustrate the process.



**Vent holes made with an awl
before flattening the collars (+)**



Flattening vent hole collars (+)



Completed stove (+)

ALTERNATIVE HOLE PATTERNS

Reducing Heat Output for Simmering

Most popular alcohol stove designs work well for boiling water but are notoriously difficult to throttle back for simmering. That's because there are only two ways to reduce the heat output of any stove and most alcohol heaters can use only the less efficient one.

The first way to reduce heat output, which offers the finer level of control, involves limiting the amount of fuel that reaches the flame. This technique is used, of course, in all canister and commercial liquid fuel stoves, usually by employing a screw-type fuel valve that's typically located either at the stove or on a remote fuel bottle. With almost all alcohol stoves, however, the entire fuel supply is always available for the duration of the burn, so there's no practical way to limit its exposure to the flame.

The second method, which is the only choice available for most alcohol stoves, involves reducing the amount of oxygen that reaches the flame. This option, however, is usually much more difficult to control since even a slight breeze can radically alter the airflow in and around the stove.

One technique that's used by a fair number of alcohol stove users is to add some type of air-restriction shield around either the vent holes of the windscreen or around the stove itself. Some Super Cat users have, for example, built "simmer rings" that can be temporarily attached to the stove in such a way as to block one row of vent holes in order to reduce heat output.

Creating airtight seals with these kinds of shields is difficult, however, and so they often don't work very well. In addition, most alcohol stove designs don't allow this type of airflow adjustment to be made in real time while the stove is operating.

Before proceeding, I should mention that one of the best approaches to simmering is not to simmer at all, but rather, to cook with retained heat using either single or double pot cozies as described in August, 2008 article "[Three Mods for Your Mug](#)". As many backpackers already know, this method can save a lot of fuel by preserving the energy that's already been added to a cook pot during the initial heating process. For meals that need extended cook times, I'd strongly suggest that you try this method first.

Building a "Simmer Cat"

Nonetheless, if you'd like to try simmering with a Super Cat, one way is to create a second version of the stove that's optimized for this purpose (let's call it a "Simmer Cat"). This dedicated simmer stove will likely offer a more reliable way to cook at reduced heat than by using an add-on that can leak air, and possibly fuel. In addition, a dedicated Simmer Cat, at least the one described below, will have a higher fuel capacity than a simmer ring-equipped main stove and thus can be operated for longer periods of time.

You can build a Simmer Cat in many ways, but probably the easiest is to construct the same stove that's described above, but without the bottom row of ventilation holes. Based upon my tests, this single-row stove will operate with a bit less than half the heat output as a comparable model that uses a double row of holes.



"Simmer Cat" with a single row of vent holes (+)

A performance comparison between similar Super Cat and Simmer Cat models is shown below. Both stoves were fueled with one fluid ounce of SLX denatured alcohol and used to heat two cups of cool room temperature water in a Snow Peak Trek 1400 titanium cook pot to a rolling boil. The fuel in both stoves was also ignited without external priming mechanisms (such as a priming pan).

Super Cat	Simmer Cat
-----------	------------

Prime time *	25 sec	25 sec
Time to rolling boil (incl prime time)	4 min, 30 sec	9 min, 45 sec
Total stove burn time (incl prime time)	6 min, 45 sec	15 min, 30 sec
* Prime time = the amount of time from ignition until the surface of the alcohol begins to boil, which also marks the point at which the cook pot can be lowered onto the stove.		

The heat output of a Simmer Cat can be further adjusted by either adding or deleting vent holes. Obviously, adding a hole is easy, while deleting a hole usually requires starting over with a new stove, so it's best to proceed slowly when experimenting. Likewise, hole sizes can be reduced, though I've found that when using a single row of vents, holes that are much smaller than 3/16" in diameter will probably lead to stove that doesn't work at all.

By the way, if you really think you need real-time control over your stove's heat output, a completely different approach to simmering is offered below in the "Accessories" section. Called the "[Swivel Cat](#)", this stove requires a separate pot stand, but allows you to make flame adjustments while the stove is operating.

Using a Simmer Cat on the Trail

When preparing a meal that requires a long cook time, most hikers will probably first want to use a standard Super Cat to bring the meal to a boil, then transfer the pot to the Simmer Cat for the remainder of the required time.

Other Hole Configurations

While the hole configuration discussed above in connection with the standard Super Cat should work fine under most conditions (including high altitudes and low temperatures), you might like to experiment with other sizes and patterns. If so, there are a few things that might be helpful to know.

The first is that the fuel capacity is (obviously) defined by the height of the bottom edge of the lower holes above the base of the can. The higher these holes are positioned up the wall of the can, the greater the potential fuel volume.

The tradeoff, however, is that if the flame jets that emanate from these bottom holes are too far away from the top surface of the alcohol, there may not be enough heat transferred to the alcohol pool to keep it boiling and the stove could extinguish itself, especially in chilly weather.

The range of distances, as measured from the bottom of the can to the bottom edge of the lowest hole, that seem to work are 1/2" to 5/8" (13mm to 16mm) for double row stoves and 7/8" (22 mm) for a single row Simmer Cat stove. The approximate fuel capacities of each of those hole heights is shown below.

Hole Height	Fuel Capacity (fl oz)
1/2" (13mm)	1.2
9/16" (14mm)	1.3
5/8" (16mm)	1.5
7/8" (22mm) Single row design	2.1

Another variable to keep in mind is that the larger the vent holes, the more wind-sensitive the stove is likely to be. The largest hole size I've found that works well is about ¼ inch in diameter. On the other hand, vent holes that are too small may not work at all. A couple of Super Cat builders have reported making stoves that use three rows of very small holes, but I've never been able to get this arrangement to work (perhaps I'm missing something).

It's also not mandatory that all vent holes be of the same size. Some of my earliest Super Cat prototypes (that worked very well) were constructed using a row of relatively large top holes, along with slightly smaller holes in the bottom row.

Also remember not to create so many holes that the structural integrity of the can is compromised. If you remove too much aluminum, the stove might not be able to safely support a pot full of water. While the stove may not actually collapse during operation, the walls might slowly warp under heat stresses, shortening the Super Cat's life.

Irrespective of the hole configuration you select, you'll want a mostly blue alcohol flame (a few short yellow bursts are OK) that flows smoothly from the vent holes without the "pumping" action that usually indicates that the fuel / air mixture is less than optimal.

Super Cat Fuels

Fuels that are appropriate for use in the Super Cat, as well as in most other alcohol stoves, have been widely discussed on the Internet, so I don't want to simply regurgitate what others have written. One of the best reviews is available on the [Zen Stove website](#).

Likewise, the names, availabilities and even colors of these fuels can vary from country to country. A good resource for international fuel information [can be found here](#).

The discussion below is a brief summary of the fuels that are either used, or might be considered for use, in alcohol stoves and reflects many of my own experiences.

DENATURED ALCOHOL

Over the years, I've tried a wide variety of fuels in the Super Cat. The best results have consistently come from [denatured alcohols](#), which usually burn hot and clean with virtually no odor or soot production. Denatured alcohols are widely available in the United States, though there is no standard formula for these products among its various manufacturers.

Ethanol

Denatured alcohol starts with [ethanol](#), also known as ethyl alcohol, which is the same type of alcohol that's found in adult beverages and which has received so much attention in recent years as an alternative automotive fuel.

To render the ethanol undrinkable (and therefore not subject to liquor taxes), a variety of "denaturants" or toxic chemicals are mixed into the ethanol to convert it into denatured alcohol. In some countries, dyes (often purple) are also added to help distinguish the product from clear nontoxic beverages such as water.

Methanol

One additive that's commonly used is a variety of alcohol called [methanol](#), also known as methyl alcohol, wood alcohol, wood spirit, wood naphtha, pyroligneous spirit and carbinol.

Aside from its use as an ethanol denaturant, methanol is also widely employed as an industrial and marine solvent, a paint remover, a car racing fuel, and as a component in shellacs, photocopying compounds and windshield-washing fluids.

The biggest problem for backpackers is that unlike ethanol, methanol is poisonous when ingested,

inhaled or absorbed through the skin (see the "[Safety Notes](#)" section above).

Methanol does, however, have combustion properties that are similar to ethanol. A comparison of ethanol and methanol, along with the petroleum-based Coleman fuel that's used in traditional backpacking stoves (like the MSR WhisperLite) is shown below.

	Ethanol	Methanol	Coleman Fuel (aka white gas, naphtha)
Energy content (Megajoules per liter)	23.5	17.9	35.5
Energy content (% of Coleman Fuel)	66%	50%	100%
Weight (ounces per fl-oz)	0.82	0.83	0.73
Weight (% of Coleman Fuel)	112%	114%	100%
Boiling point	173° F	148° F	117° F
Typical fuel weight * (7-day backpacking trip)	17.8 oz	23.9 oz	10.5 oz
* The 50% / 50% SLX blend would require about 21 ounces of fuel for this trip			

Many experienced alcohol stove users prefer denatured alcohol blends that contain as much ethanol as possible, since it has a higher energy content than methanol and is also less toxic.

On the other hand, the boiling point of methanol is lower than ethanol which means that it will vaporize more easily in cold weather (but still not as well as Coleman fuel). The brand of denatured alcohol I've used the most is SLX from WM Barr, which contains roughly 50% ethanol and 50% methanol.

At that mix, its blended energy content is about 20.7 megajoules per liter or 58% of the petroleum-based Coleman fuel. On a volume basis, that blend is also about 113% of the weight of Coleman fuel, which means that on a weight-for-weight basis, denatured alcohol contains about half the energy content of Coleman fuel.

In other words, to boil the same quantity of water on a backpacking trip, I'd need to carry twice the weight of denatured alcohol as I would Coleman fuel.

With priming, a little waste, and lots of morning coffee, I typically use about 1½ ounces (by weight) of petroleum-based fuels a day, so a 7-day trip generally would require a total of about 10½ ounces. If I carried SLX instead, I'd need roughly 21 ounces of denatured alcohol for the same trip. Of course, there are many other variables, like the weight differences of the associated stoves and accessories that must figure into a final weight-efficiency calculation.

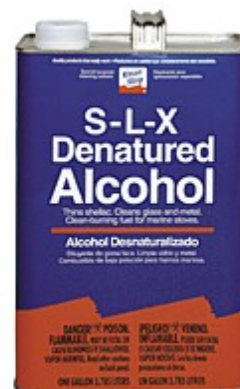

Determining the Ingredients

Processed foods sold in the United States are required to bear labels that specify their ingredients. There is, however, no such requirement for denatured alcohol products, so instead, one must turn to a document that the federal government requires be filed and regularly updated for every chemical

distributed in this country that contains hazardous components. Among the information required to be reported are the ingredients and their approximate percentage constituencies. I should also note that most other industrialized countries, especially Canada those in the European Union, have similar reporting laws.

The MSDS

Called a [Material Safety Data Sheet](#) (MSDS), one of these documents is available for every denatured alcohol product sold in the United States. They can sometimes be found in online MSDS databases, and sometimes on manufacturers' or retailers' websites. Probably the easiest way to locate an MSDS for a particular product is to simply perform an Internet query using "MSDS" and the product name as your search terms.

For your convenience, I've also collected the MSDS's for a few popular brands of denatured alcohol as well as for the two kinds of Heet that are discussed below. You can [find them here](#).

No Water, Please

When reviewing these documents, you may note that some brands of denatured alcohol contain water as an ingredient. It's been my experience—and apparently that of others as well—that even a little water can have a significantly negative impact on stove performance.

One example is Parks brand denatured alcohol. According to its 2002 MSDS, it contained 87% to 92% ethanol but also 5% to 10% water, a fact that might account for some of the negative backpacker comments that I've read about this product when used as a stove fuel. In fairness, I should also point out that in an updated MSDS released in December, 2006, water is longer listed as an ingredient, so perhaps their formula has changed.

HEET FUEL-LINE ANTIFREEZE

After denatured alcohol, the second most popular fuel for alcohol stoves is probably a product called Heet. Manufactured by Chicago-based [Gold Eagle Company](#), Heet is an automotive and small engine fuel additive that is marketed as a fuel-line antifreeze and water remover. I suspect that its popularity among hikers is largely related to its wide availability, especially in the northern U.S.

Sold in 12 fluid ounce plastic bottles at automotive stores, gas stations, and variety stores such as Wal-Mart, Heet is available in two varieties.

Regular Heet ("Yellow Heet")

The first variety is named just "Heet" and is packaged in a yellow bottle (and hence often called "Yellow Heet"). It consists, according to its MSDS, of 99% methanol, which was discussed above. If you're going to burn Heet in your Super Cat, this is the kind you want. It burns with a clean, blue flame similar to that seen with most denatured alcohols. A 12 fluid ounce bottle currently costs \$1.50 to \$2.50.

Compared with a denatured alcohol product like SLX (which contains about 50% each of ethanol and methanol), Yellow Heet has a slightly lower energy content, but also a slightly lower boiling point, so it should ignite a bit more easily in cold weather.

Because it's almost pure methanol, however, Yellow Heet is also more toxic than most denatured alcohol fuels. The toxicity of methanol is discussed at some length above in the "[Safety Notes](#)" section.



Methanol-based Heet (yellow) and isopropanol-based Iso-Heet (red) (+)

Iso-Heet ("Red Heet")

The second variety is called Iso-Heet, which is packaged in a red bottle (and hence often referred to as "Red Heet"), and consists, according to its MSDS, of 99% [isopropanol](#).

Also known as isopropyl alcohol, rubbing alcohol, 2-propanol or IPA, this is a third type of alcohol (after ethanol and methanol), that hikers sometimes burn in alcohol stoves. A 12 fluid ounce bottle usually costs \$2.00 to \$3.00.

Although it's an alcohol, isopropanol has about the same energy density as petroleum-based fuels like white gas at 30.4 megajoules per liter, yet weighs about the same as ethanol and methanol. Unfortunately, it also burns much like petroleum-based fuels in alcohol stoves, which is to say, not very well.

When ignited, Red Heet burns with a low temperature, yellow flame that will quickly deposit a coating of black soot on cook pots. If allowed to burn long enough, however, it will usually produce enough heat to bring a couple of cups of water to a boil. Most experienced users will chose Red Heet only if there's no better alcohol fuel available.



Red Iso-Heet burns with a yellow, sooty, low-temperature flame (+)

OTHER FUELS

Rubbing Alcohol

The term "[rubbing alcohol](#)" is somewhat ambiguous since it can be applied to products that are made either with ethanol or with isopropanol, both of which are discussed above.

The ethyl alcohol version is composed of mostly ethanol that's been denatured (made undrinkable) by adding a combination of acetone and methyl isobutyl ketone. Usually sold in concentrations of 70% by volume, the remaining 30% is primarily water. Because of its high water content, this version does not work very well in alcohol stoves. With the Super Cat, in particular, it's unlikely that the stove will pressurize with this fuel.

The isopropanol (or isopropyl) version of rubbing alcohol is the same compound chemically as the Red Heet discussed above, except just with more water. Usually sold in 70% and 91% (or sometimes even 99%) concentrations by volume, neither is a very good stove fuel. The 70% concentration, in fact, hardly burns at all, while the 90%+ concentrations will generally work, but with the sooty flame of Red Heet.

Distilled (Drinkable) Spirits



Distilled (drinkable) spirits are normally produced through a process that can produce a maximum ethanol concentration of 95.6% by weight. Commercial products containing this high level of ethanol are usually sold as "grain alcohol" and are available in most, but not all, jurisdictions within the United States.*

One of the most popular brands of grain alcohol is Everclear, which is sold in both 151-proof and 190-proof varieties ("proof" = 2 times the alcohol concentration by volume). A 750 milliliter bottle of 190-proof Everclear typically sells for \$18 to \$25 (usually plus sales tax), which makes it an expensive stove fuel.

One 750ml bottle would fuel approximately 25 normal burns in an alcohol stove. Or in other words, if you include sales tax, it would cost about \$1.00 every time you boiled two cups of water (I can think of better uses for Everclear).

Because Everclear is not available in my area, I've not tried it myself, but others have said that in spite of its ~5% water component, it burns well in most alcohol stoves.



During my early Super Cat testing, I did try Bacardi 151-proof rum as a fuel (75.5% ethanol by volume). The Bacardi burned cleanly, but probably because it still contains almost 25% water, the internal vapor pressure was not quite sufficient to allow the stove to pressurize (i.e., the flames could not switch to the outside of the stove). Bacardi 151 could therefore be used as a fuel for the Super Cat, but only in non-pressurized mode using a separate pot stand.

* According to the Wikipedia "...It is illegal to sell the 190-proof variety [of grain alcohol] in some states of the United States, viz.: California, Florida, Hawaii, Maine, Massachusetts, Michigan, Minnesota, Nevada, New York, Ohio, Pennsylvania, Virginia, and Washington. In some of these states, the 151-proof variety may be sold. In Canada, it is sold in Alberta but not in Saskatchewan, Manitoba and most other provinces.

Esbit Tablets

During my 2004 Super Cat testing efforts, I was curious to see if the stove would work when burning Esbit solid fuel tablets that are popular with many long-distance backpackers. Though the heat output from the tablets seemed to be about the same as with denatured alcohol, the combustion chamber would not pressurize at all. The tablets also left a gummy residue inside the stove and on the underside of the pot that caused the two to be temporarily "glued" together. Science project net result: doesn't work.



Some of the fuels tested during early development (+)

Laboratory (Reagent) Grade Ethanol

As noted above, high-concentration ethanol is normally produced through a fermentation and distillation process that is capable of producing a [maximum alcohol concentration](#) of 95.6% by weight, where the remaining 4.4% is mostly water.

To produce the kind of waterless ethanol that's required in many automotive and laboratory applications, the remaining H₂O must be removed through a chemical drying process that often involves the compound benzene.

The resultant "laboratory" or "reagent" grade product is a kind of denatured ethanol that contains virtually no water, but which is still not drinkable, either because there are trace amounts of toxic benzene remaining, or because small amounts of denaturants such as methyl isobutyl ketone or methanol have been intentionally added.

Nonetheless, this 95%+ pure, waterless ethanol is probably the best alcohol stove fuel available. Though it doesn't vaporize in cold weather quite as well as pure methanol, its high energy content (31% greater than methanol) and low toxicity (relatively speaking) make it very appealing. And at \$6.00 to \$7.00 per quart, the cost is also roughly comparable to many denatured alcohol products.



The bad news is that in the United States, distribution of laboratory grade ethanol is restricted to businesses, governments and educational institutions. However, if you're in a position to obtain some from your school or workplace, you might want to give it a try in your Super Cat.

Distilling Your Own Ethanol

The home production of ethanol in the United States is generally banned. One exception allows for the distillation of ethanol for use solely a fuel, though the current law does not specify exactly what the term "fuel" means.

The U.S. Department of the Treasury's [Alcohol and Tobacco Tax and Trade Bureau](#) (TTB), is charged with licensing private ethanol "plants", a process that starts by filing a [5-page form](#) with the agency. Once the no-fee document has been received, the TTB must make a determination about whether the

proposed use falls within the agency's interpretation of the term "fuel". While it might seem that use in an alcohol stove would qualify, my guess is that it probably does not. The following statement appears on the current TTB website:

"...TTB has received requests to use fuel alcohol in the manufacture of products such as charcoal lighter fluid, firelighter gel, and chafing dish "fuel." We must turn these requests down because these products are not within the intent of the law restricting the alcohol to "fuel use."

While it's unlikely that most backpackers would bother attempting to make their own alcohol fuel, there are almost certainly a hardcore few that have tried it (legally or not). There are a great many Internet resources available that offer both the instruction and the equipment necessary to distill ethanol at home.

Ethanol 85% ("E85")

Containing approximately 85% ethanol and 15% gasoline (or other hydrocarbons) by volume, E85 is sold as an automotive fuel in the United States and other countries primarily for use in "Flexible-Fuel" vehicles that have been modified to run on this high-octane, alternative to regular gasoline.

According to the [Wikipedia](#), there are currently "...1500 public E85 fueling stations available in the United States (out of 176,000 worldwide), at prices over 30% less than regular gasoline (when discounting the reduced fuel economy of E85), primarily in the corn-growing Midwest..."



I've not personally tried E85 in a Super Cat stove, but I've heard from those who have. They've reported that although the fuel contains only about 15% gasoline, it burns with substantially the same properties as regular gasoline. The resultant low-temperature, sooty flame apparently burns mostly yellow and fails to pressurize in the stove, making E85 largely unsuitable for use in a Super Cat. If you have any different experiences with E85, I'd very much like to hear from you.

Petroleum-Based Fuels

Petroleum-based fuels such as automotive gasoline, kerosene or white gas (Coleman fuel) are discussed about in the "[Safety Notes](#)" section above. Bottom line: they're more dangerous than alcohols fuels and they also just plain don't work.

CARRYING AND DISPENSING YOUR FUEL

Suitable Fuel Bottles

A question that comes up regularly on Internet backpacking forums relates to the kinds of containers that can be safely used to transport alcohol fuels on the trail.

The good news is that almost any plastic or metal container will work just fine. Soda or water bottles made from common high-density polyethylene (HDPE) or PET (polyethylene terephthalate) are chemically stable enough that they won't react with most alcohol fuels.

Some lightweight backpackers prefer collapsible plastic containers such as those made by [Platypus](#) or [Evernew](#), but I personally find it's more difficult to manage a "floppy", soft-sided container than one with rigid sidewalls.

Soda bottles (i.e., those used to package carbonated beverages) are a popular choice because they're lightweight, come in a large variety of capacities and are free. Because they're designed to contain beverages that are under a fair bit of internal pressure, they're also quite strong. One source, in fact, suggests that soda bottle manufacturers typically design their products to withstand internal pressures of at least 10 atmospheres (~150 psi) before bursting, even though the beverages themselves are normally packaged at only 2 atmospheres.

Most soda bottles made in the U.S. also have standard-size screw tops that are compatible with those used on the Platypus and Evernew soft-sided containers. Accordingly, they will accept accessories such as the [FireLite Red Spout caps](#) from [backpackinglight.com](#), or the [push-pull caps](#) from Platypus.

It's interesting to note that bottles used to package many non-carbonated water products have a

similar thread design (that's mostly standard among these types of bottles), but they're just different enough from soda bottles that the caps usually can't be interchanged.



Common PET soda bottles are great for transporting alcohol fuels

The middle bottle is equipped with a Platypus push-pull cap and the bottle on the right with a BPL FireLite Red Spout cap (+)

Whatever container you choose, you'll want to make sure that the cap is fully leak-proof. Fuel bottles can be subjected to several kinds of stresses on the trail, including those associated with internal pressures that can build significantly with altitude gains or temperature increases.

I've found that the push-pull or twist caps used on some disposal water bottles don't hold up very well (though others fare better). Likewise, certain flip-top caps, such as those used on most brands of hand sanitizers, will pop open fairly easily under only moderate pressure.



Some disposable water bottle caps tend to leak easily (+)

Flip-top caps can sometimes pop open under pressure (+)

On the other hand, my experience has been that folding-spigot caps of the type supplied with some sizes of the familiar [Campsuds](#) or on certain [plastic bottles](#) sold by REI, are quite durable and leak-resistant as are the tilt-top caps I've tried. Likewise, the Platypus push-pull and BPL FireLite red spout caps mentioned above are also recommended.



This tilt-type cap is quite leak and pop-open resistant (+)



A folding spigot is even more leak and pop-open resistant (+)

If you're taking a trip of more than a few days, you might want to consider carrying two fuel bottles. The larger, which would contain the majority of your alcohol, could have a standard, non-dispensing, leak-proof cap, while a second smaller (probably 4 to 8 ounces) "working" bottle could be used for actually fueling your stove. The smaller bottle, perhaps equipped with a spigot-type dispensing cap, will be much easier to handle around camp and can be refilled from the larger bottle as necessary.

By the way, there's a good summary of fuel bottle choices on the [Zen Stoves](#) website. And oh yes, it's also a good idea to mark your fuel bottle, especially if using a water or soda type, so that it indicates that the clear contents are flammable, poisonous, and are not to be confused with drinking water. Though you'll know the difference, someone else who might have need to access your pack (perhaps in an emergency) may not.

Measuring and Dispensing Fuel

There are several popular methods for measuring and dispensing fuel to your stove. One obvious way is to carry a lightweight kitchen measuring spoon that can be filled to an appropriate level from your fuel bottle. If you use a bottle with a wide enough mouth, you might even be able to dip the spoon into the bottle to scoop the fuel, rather than having to pour the fuel onto the spoon.

A one-tablespoon size measurer works well because 2 tablespoons = 1 fluid ounce, which is a normal fuel "load" for the Super Cat stove. If you need to measure quantities in other than ½ ounce increments, it's fairly easy to estimate the differences with this size spoon.



**One-tablespoon fuel measurer along with
8 fl-oz "working" fuel bottle with folding spigot cap (+)**

Weights: spoon = $\frac{1}{4}$ oz, bottle = 1 oz

If you like this idea, I'd suggest selecting a measuring spoon with a handle long enough to minimize the chance that you'll end up with alcohol on your hands, since as noted in the "Safety Notes" section, most alcohol fuels contain methanol, which can be toxic when absorbed through the skin.

Another measurement option is to mark the Super Cat with lines scratched into the inside walls using a nail or awl at $\frac{1}{2}$ fluid ounce fill increments. You can establish those increments using a one-tablespoon measuring spoon and water, marking the level each time you add a tablespoon ($\frac{1}{2}$ fluid ounce) of liquid.

A third option is to carry a bottle that includes a built-in measuring chamber. The bottles sold by [Brasslite](#) are inexpensive, use spigot-type dispensing caps, and are available in either 8 or 16 ounce sizes. Though I've not tried them myself, I understand they work well.

Similar dispensing-reservoir bottles are also used to package a variety of automotive fuel additives and are widely available in auto parts stores. Likewise, most of the [Coolbrew coffee](#) products are sold in similar bottles. I would still prefer the Brasslite models, however, because the discharge port is equipped with a cap that doesn't need to be removed when fuel is dispensed.

Starting and Using the Stove

SAFETY FIRST

As mentioned above in the "[Safety Notes](#)" section, all alcohol stoves emit some level of carbon monoxide, so you'll want to work in a well-ventilated room if you decide to test your Super Cat indoors. I've done a great deal of stove testing in my basement without problems, but I make sure to keep the door and windows open and as much air moving inside as possible.

You'll also want to work in an area that's clear of anything that could catch fire if something goes

wrong. I always keep my work area clear of combustibles and generally operate the stove inside of a 12" wide circular metal pan of the type used for automotive oil changing. If I somehow manage to tip the stove over during operation, the pan will confine the flames.

In addition, I also always have a "snuffer cup" (described below) handy to extinguish the stove through suffocation if necessary, as well as a source of water nearby should things really start to get out of hand. Note that unlike like petroleum-based fires that often spread when water is applied, alcohol-based flames can usually be quickly extinguished by drowning.

FUELING and LIGHTING

The exact manner in which you fuel and light your Super Cat will depend in part upon the accessories (if any) that you employ. For example, if using a windscreen like the [Fire Bucket](#), you'll need an ignition technique that's appropriate for this type of wind barrier. Likewise, if using an optional stand that has a built-in primer pan, ignition will be a bit different than that discussed below.

For purposes of simplification, I'll describe fueling and lighting a "naked" Super Cat stove that's set up in a wind-free environment. Specific recommendations about alternative techniques that might be appropriate when using certain Super Cat accessories are included in the same sections where the construction and use of those options is discussed.

Step 1: First, position the stove on a stable surface that won't be damaged by high temperatures. The bottom of the stove will get very hot during operation, so don't test it, for example, directly on your kitchen counter. Also be certain that the stove is sheltered from winds. The Super Cat is extremely lightweight and you don't want it to blow over while burning, possibly spilling flaming alcohol on you or your equipment.

Step 2: Next, measure one fluid ounce of alcohol fuel and pour it into the bottom of the stove. Never, of course, fill a stove that is still hot from a previous operation – it should be cool to the touch when adding fuel. Be sure to clean up any spills on your hands or other surfaces before proceeding. Also, place any flammable items (like matches or your fuel bottle) well away from the stove.

Step 3: Now ignite the fuel, probably most easily accomplished by extending a lighted match through one of the lower vent holes, or alternatively, into the stove from the top. Once the fuel has ignited, flames will emerge through the top, though they may be difficult to see in bright daylight. Placing your hand near the top of the stove will allow you to feel the warmth in order to confirm ignition.



Fuel ignited (+)

Step 4: Wait 20 to 30 seconds to allow the flames to warm both the stove and liquid alcohol, during which time you'll note an increase in heat output. This warm-up process is often referred to as "priming" and is usually complete when you can see the surface of the alcohol pool bubbling (boiling).

You can now place your pot directly on top of the stove, making sure that it both covers completely, and is centered over, the top stove opening. With the pot in place, the combustion chamber should now pressurize and the flames should shift from emanating from the top of the stove to emerging from the side vent holes.



The Super Cat in operation (+)

Note that if the flames are extinguished when you place your pot on the stove, then your Super Cat is probably starved for oxygen (i.e., it's running too "fuel rich"). To fix the problem, either add a few more vent holes or enlarge the existing ones slightly. Proceed slowly with this process, however. Too much oxygen will cause the flame to become "fuel lean" and turn yellow, significantly reducing the efficiency of the stove.

Now cook or boil for the desired time. You'll find that one fluid ounce of fuel will probably last for 7 or 8 minutes, which is usually plenty of time to bring two cups of water to a boil. Air and water temperatures, wind conditions, elevation, and other factors will affect your boil times, so you can adjust your fuel "load" as appropriate.

To maximize efficiency, it's best to use a tight-fitting lid on your pot and to surround the stove and pot with a windscreen if there's even the slightest breeze (more on windscreens below).

OPERATIONAL PRECAUTIONS

Be especially careful if you need to remove the pot from the Super Cat while the stove is in operation. Some of the things that can happen:

1. Lifting the pot quickly and vertically off the stove can create a momentary vacuum inside the combustion chamber. The flames on the sides of the stove will disappear, but an instant later, will likely re-appear with a "whoosh" back inside of the stove.

What's happening is that the expanding alcohol gases go unburned for a moment when the outside flames are extinguished, but then ignite again inside. I don't think this phenomenon is particularly dangerous, though it can be a bit startling the first time it happens. It's not nearly as significant, however, as the flare-ups that can sometimes occur with white gas stoves when they ignite.

The best way to prevent this from happening is to lift the pot slowly and move it sideways off the burner. This way, the transition cycle from outside flames to inside flames can occur smoothly, without a flame-out/re-ignition cycle. Should the flame extinguish, but not re-ignite on its own,

you'll need to manually re-light it.

2. Sometimes during operation, a little alcohol might collect on the underside of your pot. When you remove the pot from the stove, this alcohol can continue to burn for a few moments, making it appear as though the bottom of your pot is on fire. This small flame is easy to extinguish, however, by either blowing it out or by setting the pot on the ground to smother it.
3. If the bottom of your pot or the top rim of the stove becomes gummy with cooking residues, the stove could (because it's so lightweight) actually stick to the pot bottom. When you then lift the pot, the stove could lift along with it. A moment later, it could also "un-stick" and fall, spilling flaming alcohol everywhere. To avoid this problem, always keep the pot bottom and top stove rim free of sticky substances.

STOPPING THE STOVE

Most of the time, you'll probably just allow the Super Cat to burn itself out after a cooking operation. If you want to deliberately stop the stove before the fuel is spent, however, there are at least a couple of methods.

Before proceeding, I should emphasize that it's almost always a bad idea to attempt to blow out the flame in an operating Super Cat for at least two reasons: (1) It probably won't work, since you'll just be adding oxygen to make the flame burn hotter (the "blacksmith forge" effect); and (2) if you blow hard enough, you might accidentally cause flaming alcohol to splash outside the stove through a ventilation port, perhaps starting a fire nearby.

Instead, a Super Cat can be reliably stopped as follows:

1. In an emergency, you can douse the stove with water. As noted above, the flames can be extinguished in this way without concern about spreading them (as with a grease fire).
2. A more graceful technique is to simply deprive the flame of oxygen. One way to suffocate the burn is to use your empty cook pot as a "snuffer" by inverting it over the stove. The less air that's trapped under the pot, the more quickly the flames will extinguish. I normally use a Snow Peak Trek 1400 titanium cook set (shown in the photos above) whose top is also a 2-cup fry pan. When this fry pan is used as a snuffer, the flame is usually extinguished within a second or two.

Because an empty cook pot may not always be available, however, a more dependable method is to construct a dedicated "snuffer cup" from any lightweight aluminum can that's slightly larger than the stove. See the "[Accessories](#)" section below for more information about building and using a snuffer cup.



Super Cat stove with a "snuffer cup" (+)

See "[Accessories](#)" section below for build instructions

RECOVERING UNBURNED FUEL

If there's unburned fuel remaining in the stove after a "snuff-out", you'll have to decide whether or not to try to recover it. If the amount is small or if it contains debris or other contaminants that you'd rather not empty into your clean fuel supply, you might elect not to bother. In this case, any alcohol left inside the stove will quickly evaporate.

However, if the amount is significant, you'll probably want to salvage the leftovers. Because of the side vent holes, however, a Super Cat's unburned fuel usually can't just be poured back into the fuel bottle without spillage.

My preferred removal technique is to suction the remaining fuel using a plastic eye dropper such as that made by Nalgene and [sold by REI](#) for \$0.30. I've used this dropper for some time (which is so light that it doesn't register on my scale) and it works very well.



**A plastic Nalgene eye dropper
can quickly recover unburned fuel (+)**

Another option, if you carry a snuffer cup, is to quickly dump the stove into the snuffer cup so that the fuel can't leak through the side vent holes. A small notch that's either bent or cut into the inside rim edge of the snuffer cup will allow the fuel to be easily pored back into your alcohol bottle (more below on this idea in the "[Accessories](#)" section).

EXTENDING THE BURN TIME

The fuel reservoir capacity of the standard Super Cat described above is around 1½ fluid ounces, which if full, should provide a burn time of up to 12 minutes or so (depending on conditions). To increase the effective burn time, one choice is to use two stoves, moving the pot back and forth between them.

As stove #1 shows signs of burning out, stove #2 can be lighted and the pot transferred a few moments later. Stove #1 can be allowed to cool, then re-filled and re-lighted if desired. The total burn time in this case would be limited only by the available fuel supply. By the way, I refer to this technique as the "Super Cat shuttle" and while it works well in calm conditions, it also requires using two separate windscreens when it's windy.

Another obvious way is to increase the volume of the stoves, but there may be problems with getting the stove to pressurize as discussed above. One Super Cat builder, Jason Klass, has developed a higher capacity version of the Super Cat for use mostly in cold weather that he calls the "Snow Cat". You can [read more about it here](#).

HIGH ALTITUDES and LOW TEMPERATURES

The Super Cat has seen a lot of use in both high altitude and low temperature environments over the past few years. I regularly receive email reports from users that have tested the stoves under some fairly extreme conditions and they largely confirm my own experiences, which is to say that the Super Cat generally works just fine.

Increased altitude lowers water boiling temperatures, of course, but seems to have little effect on the performance of the Super Cat. In fact, because of the reduced air pressure, alcohol fuel often lights

more easily at higher elevations that it does at sea level.

Sub-freezing temperatures can make it a bit more difficult to light most alcohol fuels, however, so it's often useful to maintain a small "working" bottle of fuel in a coat pocket to keep it warm. Pre-warming the stove by holding it in your hands before fueling can also help. Likewise, using a high-methanol content fuel, which has a lower vaporization temperature than does ethanol, is another way to improve cold-weather performance, but you'll want to be especially careful with these fuels since higher methanol content also means higher toxicity.

The use of either a Fire Bucket windscreen, or of an [optional stand](#) such as those discussed below, can further improve winter operation. If the Super Cat is in direct contact with very cold ground, conductive heat losses can sap much of the stove's energy, perhaps even causing the alcohol to stop boiling, which will probably kill the flame. Insulating the stove from the ground in some manner will usually solve this problem.

Both the Fire Bucket and the optional stands do so by creating an insulating airspace under the stove, but in really low temperatures, you might also want to add a bit of home fiberglass insulation to these air spaces.

On the other hand, if you're backpacking in these kinds of temperatures, you'll may also need to regularly melt snow for drinking water, in which case an alcohol stove is probably not the best choice. Instead, you're likely better off using a stove that's optimized for winter use, such as a pressurized white gasoline model, or perhaps a liquid-feed butane/propane burner like the Coleman Powermax Xtreme.

LIGHTERS and MATCHES

There are, of course, many ways to ignite any stove and most experienced backpackers will usually have already settled upon a personal favorite. Nonetheless, I thought it might be useful to weigh in with a few Super Cat-specific comments. I'll also note that there's a good bit of useful information about fire starters available at the [Backpack Gear Test website](#).

Lighters

One of the more popular methods of lighting some kinds of backcountry stoves is with butane lighters such as those made by Bic, Ronson, Tokai, Calico and others. Aside from being inexpensive, these lighters are also lightweight and durable, but there are at least a couple of issues, especially when used with an alcohol stove like the Super Cat.

The first, of course, is that these lighters are designed primarily for use with tobacco products, so your hand ends up very close to the flame. That's perhaps OK for a cigarette, but not so good for starting a stove where accumulated flammable vapors can sometimes cause brief flare-ups during ignition. This design can also present a burn hazard when the lighter needs to be held horizontally, rather than vertically, in order to start a stove.

A second problem is that most of these lighters don't work very well, or perhaps at all, in cold weather. Most inexpensive lighters are fueled with regular butane (also known as n-butane), which has a boiling point of 31°F (-0.5°C). As soon as the air temperature drops much below freezing, the butane will simply refuse to vaporize and the lighter will cease to function. I've found this to be the case even if the lighter is stored in a warm jacket pocket because the moment the butane gas is exposed to the cold air, it immediately becomes uncooperative.

A few lighters, such as those made by Ronson, are fueled with isobutane, which has the same molecular formula (C₄H₁₀) as n-butane, but a different structural formula (i.e., it's a butane "isomer"). The boiling point of isobutane is 11°F (-11.7°C), which makes its cold weather performance better than n-butane, but even so, vaporization at temperatures below freezing can still be a bit sluggish. And when temperatures drop below isobutane's boiling point, these lighters will likewise cease to work at all.



Widely-available Bic lighter * (+)



Ronson lighters use isobutane for improved cold weather use (+)

* Bic and most other inexpensive butane lighters are probably filled with standard n-butane fuel, but because the ingredients are not listed on the packaging and because related MSDS documents are either not available or difficult to obtain (mostly from Chinese sources), I haven't been able to determine the precise fuel components. Ronson, in contrast, does make MSDS's for its products [readily available](#).

An alternative is a butane candle-style lighter, where the flame port is moved away from the hand via a metal extension tube. This design solves the hand-to-flame proximity problem, but not the cold weather performance issue. And at weights of 2 to 3 ounces, these kinds of lighters are also significantly heavier than the ½ ounce or less of standard models. They are, however, very handy for testing alcohol stoves in a home or laboratory setting.



Dollar-store candle lighter (+)



Solo brand candle lighter (+)

Most candle-style lighters use [piezoelectric](#) ignition where a small spark is generated at the end of the extension tube in order to ignite the butane gas. It turns out that even if the lighter's butane gas won't

ignite, this spark alone is sufficient to start some kinds of stoves, most notably butane/propane canister models.

Interestingly, I've discovered that the spark alone from some candle-style lighters can also be used to start a Super Cat. For this ignition method to work, however, the lighter's spark point must be located near the tip of the extension tube (rather than at some distance up the barrel) and the lighter's tube must usually be dipped into the alcohol pool for ignition to occur. If lighting the Super Cat inside a windscreen, this spark-only method still requires that the lighting hand usually be placed directly above the stove during the starting process (which makes the user susceptible to burns) and thus is not recommended.

If you perform a quick search on the web, you'll find that butane lighters are offered in a huge variety of styles and prices, with some supposedly "hardened" for use in outdoor survival situations. All told, however, I'd suggest passing on such products and sticking with the venerable wooden match that works in a much broader range of conditions.

Wooden Matches

While we tend to think of the common wooden friction match as pretty low tech these days, it was [first introduced in 1827](#). For lighting most backcountry stoves, however, it remains a great technology.

Today's wooden matches are generally reliable and safe, allowing the user to position his or her hand some distance from the flame. They also perform well under even extremely cold conditions, though dampness, of course, can sometimes cause problems. The heads of these matches will likewise usually burn long enough to start most stoves, even if the wooden splints don't catch fire (as might be the case when it's very windy).

There are specialty matches, of course, that are designed for use in extreme environments and that are usually coated with wax or similar substances to help make them waterproof. For everyday use with a Super Cat stove, however, these types of matches are probably overkill and unnecessarily expensively. They're also harder to light, and because more force is generally required while striking, I find that they also break fairly easily (at least that's the case with the Coghlan's waterproof matches pictured below).



Storm-proof matches from REI (+)



Coghlan's waterproof matches (+)

Instead, I normally use standard wooden matches in both the strike-anywhere and safety match varieties ("safety matches" require a compatible striking surface, normally located on the side of the box). Wooden matches are typically available in two sizes: (1) the larger "kitchen match" size which is 2.4 inches long and has a beefier splint and (2) the smaller "penny match" size, which is 1.7 inches long and has a thinner wooden splint.



I like both the strike-anywhere and the safety versions of wooden matches in both the kitchen and penny sizes (+)

Because these matches are not waterproof, it's important to store them in watertight zipper-bags or hard-sided containers. If you're a "belt-and-suspenders" kind of backpacker (such as myself), you may also wish to carry a separate supply of storm-proof matches for starting emergency campfires under particularly challenging conditions.

I will also note that a final advantage of wooden matches is that they can be easily used with Jim's simple wine cork "match extender" accessory when lighting a Super Cat that's positioned inside a windscreen. See the "[Accessories](#)" section below for more details.



Using a wine cork match extender (+)

Accessories

WINDSCREENS

As noted in the Super Cat companion article, [The Fire Bucket Stove System](#):

"...wind is public enemy #1 for any backpacking stove system, but because of their low flame velocities, alcohol and tablet-based stoves are particularly susceptible to the disruptive effects of air movement. Unprotected from even a slight breeze, these stoves can quickly become unusable."

Pretty much sums up the problem. Though I'm discussing this matter in the "Accessories" section, an effective windscreen is essentially mandatory if you actually intend to use your Super Cat (or most any alcohol stove) in the real world.

Traditional Windscreens

The Internet is replete with easy-to-build windscreen designs that are usually constructed from some variety of thin sheet metal and populated with a row of ventilation holes around the bottom. While these designs are certainly better than nothing, I would contend that there are better ways to solve the problem.

I won't address all the issues associated with traditional windscreens here, since I do so at some length in the [Fire Bucket article](#), but I will say that screen ventilation issues probably create the most compelling performance problems.

As I also note in the Fire Bucket article:

"...Unless fairly large in size, the ventilation holes used in most of these designs can offer a fair amount of resistance to air entering the windscreen, which can starve a flame for oxygen. If the holes are large enough to permit the free flow of air, then they probably also contribute to internal air turbulence when the wind blows."

The KiteScreen

One alternative approach to solving some of these problems, discussed in my [KiteScreen article](#), is a fabric or film-based screen that's anchored to the ground and that's large enough to protect the entire cooking setup. This design works particularly well for top-mounted canister stoves that are otherwise difficult to safely shield from the wind.



Tyvek-based KiteScreen (+)

KiteScreen made from Reynolds oven bags (+)

[The Fire Bucket Stove System](#)

Another approach, however, is the Fire Bucket itself. The Fire Bucket starts with a traditional windscreen design, but then incorporates two key changes that significantly improve wind protection for the Super Cat (or most any other alcohol stove).

The first change is to replace the traditional row of ventilation holes with a single, large ventilation port that's situated on the downwind side of the barrier. The second involves elevating the stove onto an open-grate burn platform so that it's much less affected by the supply air flowing into the screen.

The synergy of these two changes also allows for a design that can serve not only as a windscreen, but also as an efficient stand-alone stove for burning wood and solid fuel tablets all at a weight (in its lightest implementations) of about two ounces. It likewise permits the addition of a series of accessories (like the "wind shade") that can further enhance its functionality. The photos below show one of my favorite versions of the Fire Bucket that can be collapsed for transport on the trail.

The Super Cat and Fire Bucket together form an efficient, lightweight, integrated stove system that's easy to build and fun to use. For more information, please see the [Fire Bucket article](#).



Fire Bucket windscreen with Super Cat alcohol stove (+)

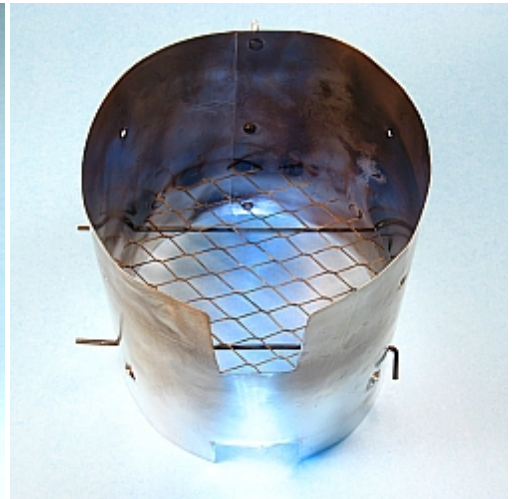

Top view shows burn platform (+)

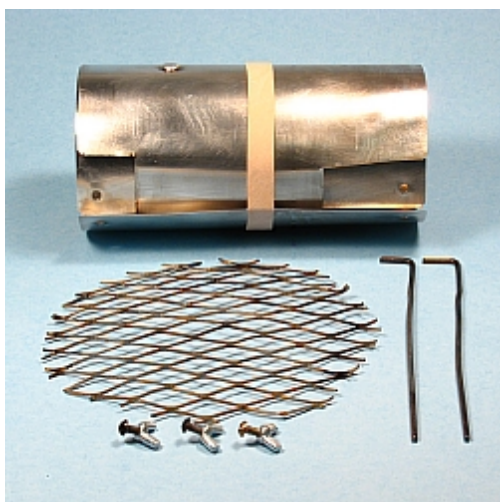

Disassembled for transport (+)



Shown with optional wind shade (+)

OPTIONAL STANDS

If you decide to build a Fire Bucket, you normally won't need a separate stand for the Super Cat, since the Fire Bucket includes a built-in, elevated stove platform. If you want to use a traditional windscreen, however, or if you'd like to build a handy test platform, an optional stand can make a lot of sense.

In April of 2005, I published plans for a stand that a fair number of Super Cat users constructed, but a year later, came up a design that I thought was superior. Below are summarized some of the advantages of using both a separate stand in general, and of the second-generation design in particular.

Why Build a Separate Stand?

- The Super Cat just might be an example of a piece of ultralight backpacking gear that's actually a little too light. A fair amount of caution must be exercised when using the stove on uneven ground or in windy environments, since its miniscule weight (0.2 oz) makes it prone to tipping or blowing over under those conditions. The small incremental weight of a stand by itself can help stabilize the stove.
- The stand creates a wider base with fewer ground contact points, improving stability.
- The second-generation design allows the stove to be further stabilized by staking it to the ground. I often insert a pair of slim tent stakes through the two holes in the base of the stand, then push them into the ground. This arrangement virtually eliminates any possibility of the stove tipping or blowing over.
- The docking socket feature allows different stoves to be used with the same stand since there's no permanent connection required between the two. The socket is tight enough, however, to hold the stove very securely.
- The stand protects the bottom of the stove from damage. If the stove alone, for example, is placed on a gravel surface, the weight of a pot filled with water can sometimes push the bottom's soft aluminum into the sharp edges of stones, causing dents and possibly even punctures. The stand eliminates this hazard.
- The airspace trapped under the stand base serves to insulate the stove from cold ground. Doing so solves pretty much eliminates the conductive heat losses to the ground that can otherwise ruin the performance of an alcohol stove when used in cold weather. For use at really low temperatures, it's also possible to fill the base with fiberglass insulation for even better performance.

- This same airspace also protects the surface under the Super Cat from the heat that's produced by the stove. I can now use the stove directly on my workbench without having to worry about cooking the surface. The airspace also protects the vegetation under the stove when used on the trail.
- The base allows the effective use of the "snuffer cup" that's described below. The snuffer cup seals well against the uniform surface of the base, permitting the stove to be easily and reliably extinguished at will. A great fuel-saving and safety feature.
- And finally, the top of the stand base can serve as a priming pan for the stove. Adding a few drops of alcohol primer to the base just outside the wall of the stove helps the stove come up to operating temperature faster and also makes it easier to light the stove, especially in cold weather.

Now, rather than having to reach over top edge of the stove with your match or lighter to ignite the alcohol fuel, it's possible to simply light the primer outside the stove (the flame quickly spreads inside). The outer ridges that are stamped into the base can's bottom conveniently keep the priming fuel from spilling over the edges.

The Fire Bucket, with its built-in, elevated stove platform, provides most of the same advantages as a separate stand, especially when used with its optional stove holder.

Nonetheless, if you'd like to build a stand, plans for both the first and second-generation models are included in separate documents, accessible using the links below. By the way, a note for stand fans: the first-generation plans include links to photos of several discarded design ideas that you might find interesting.



Second-generation stand (+)

[Click here for build instructions](#)

(Recommended version)



First-generation stand (+)

[Click here for build instructions](#)

THE SNUFFER CUP

If you happen to over-fuel the Super Cat, it's very nice to be able to extinguish the flame before the alcohol has burned itself out. You might want to stop the stove to in order to recover unburned fuel, or maybe for emergency reasons.

As discussed above, if you have an empty cook pot handy, you might be able to invert it over the stove to deprive it of oxygen, though because of the relatively large volume of air inside, that process could take a while. Alternatively, you can build a dedicated, low-volume vessel that can quickly smother the flame. I call this accessory a "snuffer cup".

In either case, the vessel you use to smother the Super Cat must form a reasonably airtight seal against the surface upon which the stove is positioned. If air can flow under the edges of the smother vessel, it won't work very well, since oxygen will continue to fuel the flame. For this reason, the snuffer cup's mating surface is as important as the cup itself.

Selecting a Can

Any metal can that's slightly larger than the Super Cat itself will usually work as a snuffer cup, though I've found that an empty 5½ or 6 ounce aluminum pet food can is about perfect for the task. If you also build the second-generation stand discussed above, it's probably best to use the same brand of can for both projects to ensure an optimal fit between the two.

Most of the pet food cans in this size range that I've examined appear to be almost identical in dimensions, though the bottom ridge pattern can vary from brand-to-brand. Any of these cans should be tall enough to cover a Super Cat that's made from the most common of the 3 ounce can sizes without air gaps.



Snuffer cup aluminum can possibilities (+)

Note that the 6 ounce Iams can (L) is slightly taller than another popular size

However, if you dock the stove with a stand (which raises the height a bit), or build the Super Cat from a slightly taller can, you'll probably also need a taller snuffer cup.

One option is just to search for a can with sufficient "head room". Among the pet food products inspected, I've noticed that the 5½ ounce Mighty Dog cans are a bit taller than most. Likewise, the 6 ounce size of Iams cat food (which may now be available only in the veterinary formulas) is about 1/8 inch taller than similar products.

Another option is to bend the bottom of the can outward a little by pressing firmly in the middle or alternatively, by working a blunt metal tool (such as a socket wrench extender) around the bottom's ridges in order to flatten and extend them.

Adding a Knob

Though not mandatory, a knob positioned at the top of the snuffer cup will make the cup easier to handle and can also help keep your fingers from being burned when the cup is lowered onto a flaming stove.

A small wooden knob can be purchased from a hardware store or easily constructed from portion of a wine cork (either plastic or natural) or a scrap of wood. The knob can then be attached to the snuffer cup by first punching a small hole in the middle of the bottom surface of the cup along with a similar hole in the middle of the bottom of the knob. A small diameter sheet metal screw, perhaps ½ inch long, can then be used to join the two.



This small wooden knob was found at Home Depot (+)



This knob was made from a wine cork (+)

Weights

A 5½ or 6 ounce aluminum pet food can will typically weigh about ½ ounce, while a comparably-sized steel can will probably weigh about 1½ ounces. A knob and screw will add about ¼ ounce to either for a total of ¾ ounce for aluminum and 1¾ ounces for steel.

Fuel Recovery

As noted above, a bonus use for the snuffer cup is to assist in the recovery of unburned fuel. Because of the Super Cat's side vent holes, it's difficult to pour unspent fuel directly from the stove back into a fuel bottle without spillage. Instead, you can quickly dump remaining the fuel from the stove into the snuffer cup first, and then pour that fuel from the cup into the bottle.

A small notch that's filed or bent into the inside rim of the snuffer cup, as shown in the photo below, can facilitate the pouring process without compromising the cup's air seal. Thanks to Ernie Priestley from Seattle for this great idea.



A small notch filed into the inside rim of a snuffer cup can assist with fuel recovery (+)

Using the Snuffer Cup with a Fire Bucket (or other Windscreen)

You can use a snuffer cup to stop a stove that's operating inside a windscreen such as the Fire

Bucket, but you'll need to modify both the cup and your technique. That's because lowering a snuffer cup into place holding its top-mounted knob (while the stove's flames are raging inside the bucket) is difficult to do without burns.

One solution is to remove the knob, then pass a thin hook or nail-type tent stake from inside up through the center hole to create a "handle" for the snuffer cup. Also, when lowering the cup into place over the Super Cat, it helps to tilt the cup towards the back of the windscreen as it descends in order to direct the flames away from you hand.

For more information about these modifications (including photos), please see the [snuffer cup section](#) of the Fire Bucket article.

JIM'S MATCH EXTENDER

If you'd like to increase the safety distance between your hand and the Super Cat when lighting the stove with a wooden match, you can make a simple extender from an ordinary wine cork (either a natural or a plastic cork works fine). Such an extender is particularly useful when it's necessary to reach over the top edge of a windscreen in order to light the stove. Because alcohol vapors can often accumulate inside the walls of a windscreen prior to ignition, it's best to keep your hand outside the screen in case there's a flare-up.

You can construct a match extender by boring a small hole into each end of the cork using an awl or a nail. These holes, which need be only about $\frac{1}{2}$ inch deep, can then be used to hold a wooden match at one end, and some sort of handle at the other. Most corks weigh less than $\frac{1}{4}$ ounce, and if you're a gram counter, you can even cut the cork in half to further reduce the weight.

The handle I generally prefer is a thin titanium tent stake (as shown below), though a slim wooden branch, a Fire Bucket pot support, another wooden match (preferably spent), Jim's [bagel toaster](#), or even a length of coat hanger wire all work well.

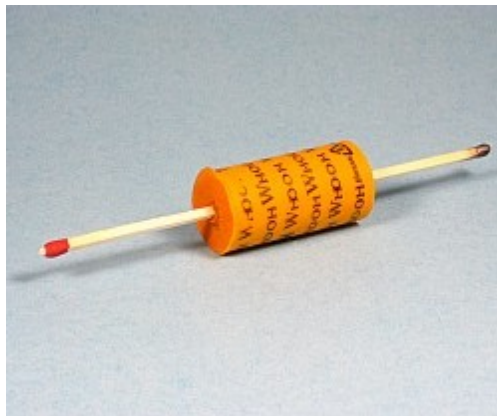

Using a spent match as a short handle (+)

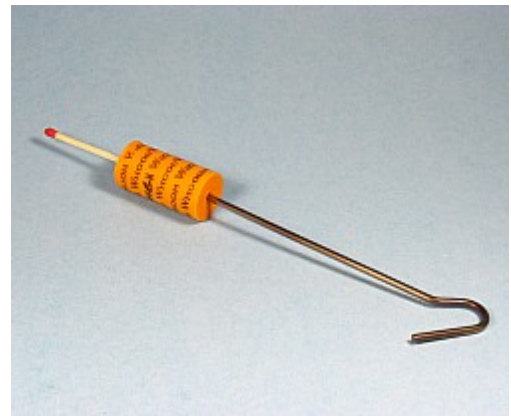

A thin titanium tent stake makes a longer handle (+)

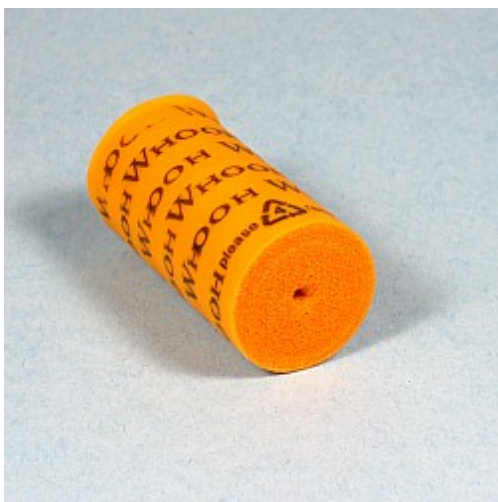

A small hole is bored into each end of the cork (+)



Positioning the match extender (+)

To use the extender, first insert the handle in one end of the cork, and an unburned match in the other. Then strike the match with the extender in place and move the match towards the stove while holding the handle end.

OTHER ACCESSORIES and MODIFICATIONS

Fiberglass Wicking

One modification that I've tried is lining the bottom of the Super Cat stove with a small amount of fiberglass insulation, held in place by a patch of aluminum screen. Some other alcohol stove designs use fiberglass as a wicking agent, so I was curious to see if there was any effect on performance. About the only impact it had was to slow the stove down a bit, with boil and total burn times both increasing by about 25%. The fiberglass did help keep the alcohol fuel from sloshing around quite as much (depended on fill level), but I ultimately concluded that the addition of fiberglass otherwise had little value.

Priming Cord

Some stove builders, such as Jason Klass, have done a good bit of experimentation with the Super Cat and its derivatives. One idea that Jason has promoted is wrapping a length of [thin Kevlar cord](#) around the base of the Super Cat a few times to absorb a bit of alcohol priming fuel. This idea, was I think, adapted from a design originated by Tinny at [minibulldesign.com](#).

This cord, which serves as an alternative to a priming pan, allows the stove to be ignited from the outside, while likewise reducing priming time. The cord would interfere with inserting the Super Cat into a holder or stand equipped with a docking socket, but if you like the idea, you could probably wrap the cord around the docking socket instead. Jason has developed a number of other innovative stove and windscreen concepts that can be [viewed on his website](#).

Priming Cap and Flame Column Compactor

Partially covering the top opening of the Super Cat with a metal disk that includes a center hole about 1" in diameter can reduce priming time from 25 or 30 seconds to perhaps 15 seconds or less without requiring (as most other priming methods do) any additional fuel.

This method works by absorbing more of the heat that's produced by the stove just after ignition and feeding it back into the alcohol pool to accelerate the fuel boiling process.

There are at least a couple of ways to restrict the top opening. One is to simply cut a disk from aluminum of the appropriate size, make a center hole, then rest the disk on top of the stove. Unless the disk is secured, however, it can sometimes "jump" off the stove with a pop when the accumulated alcohol fumes are ignited.

An alternative is to glue the disk permanently into position using a high-temperature epoxy such as [J-B Weld](#). I've tried this method myself, but found that even though the adhesive is rated for use up to 500°F, it tends to eventually fail with use. Nonetheless, it usually works well enough for as long as it lasts.

In either case, it's important that the top surface of the disk not extend above the upper lip of the Super Cat, otherwise, the stove might leak air around the rim and fail to pressurize.

The photos below show two disks cut from the bottoms of 3 ounce pet food cans. Either round or rectangular holes work fine, though rectangular holes are easier to make (the one below was carefully cut with a box opening knife). A metal file can be used after cutting to clean up the edges.

When in use, the cook pot can be lowered onto the Super Cat as usual after the priming process (which should now require less time) is complete.



These priming caps were made from the bottoms of 3 ounce pet food cans (+)



Priming cap in position atop the Super Cat (+)

Another interesting method, developed by [Zen Seeker](#), requires the use of an unopened 3 ounce aluminum can. Rather than opening the can from the top as usual, the user first cuts a hole about one inch in diameter in the bottom center of the can, then removes the can's contents through this hole.

The result is an "upside-down-Super Cat" whose side vent holes must be drilled, rather than punched, since most punches can't work through the restricted top opening. The principal disadvantage of this design is that the inverted Super Cat now won't fit into the docking socket used for the stands discussed above, nor into the optional stove holder that can keep the Super Cat centered inside of a Fire Bucket windscreen.

On the plus side, concentrating the open Super Cat flame into a more compact column allows the stove to be used more effectively in what I call "open burn mode". That is, positioning the cook pot above the stove on some manner of pot stand, rather than directly on top of the stove as one normally would. Raising the pot in this way offers another way to reduce heat output that might be useful for simmering.

The "Swivel Cat"

This final accessory is not actually directly related to the Super Cat itself, but rather, is a different kind of alcohol stove altogether.

Called the "Swivel Cat" for reasons that are probably apparent from the photos below, it offers an alternative way to cook at reduced heat levels. The idea is similar to that behind the "Simmer Cat"

discussed above, except that it allows heat output to be adjusted in real time while the stove is operating.

The Swivel Cat is not very hot-burning, though, so it's really only useful for simmering. And unlike the Super Cat or Simmer Cat, it doesn't include a built-in pot stand, so it requires some type of independent support (it works great in the Fire Bucket, however).

The Swivel Cat is made from the same kind of 3 ounce aluminum can used for the Super Cat, except there are no vent holes in the sides. Instead, a circular disk, slightly larger than the top opening of the can, needs to be cut from aluminum flashing and attached as a swiveling lid.

This lid connects to the stove via a small "L" bracket, which is also cut from aluminum flashing and is installed at the top edge of the stove as shown below. The lid attaches to the bracket using a single, loosely fitting rivet or machine screw connection. It also needs to be installed in such a way that it mates fairly closely with the top rim of the stove.



Low simmer lid position (+)



Moderate simmer position (+)



Fully-opened position reveals the "L" bracket inside (+)



Fully-closed position (+)
(Note the "L" bracket rivets on rear wall)

The Swivel Cat uses normal Super Cat fuels and is ignited over the top rim. Once it's burning robustly, a pot can be positioned at the desired height above the stove on separate supports. Assuming the stove is encased in a windscreen, heat output can be increased or decreased as follows:

- First, remove the cook pot from its supports. Then, using the end of a metal tent stake, rotate the swiveling disk so that it covers either more or less of the top stove opening. The more of the opening the lid covers, the lower the heat output will be. In fact, if the disk is closed all the way, the flame will be extinguished.
- Once the desired heat level has been obtained, the pot can be returned to the cooking position above the stove.

Because there are no ventilation holes, the Swivel Cat will hold almost 2½ fluid ounces of fuel. If filled to capacity and operated at a low simmer, the Swivel Cat will burn for a very long time before it needs to be replenished.

Resources

FURTHER READING

While the Internet abounds with information about alcohol stoves, there are three online resources that might be of particular value to you.

1. Backpackinglight.com describes itself as "The Magazine of Lightweight Hiking and Backcountry Travel". The staff at BPL, especially Will Rietveld and Roger Caffin—who have prepared most of the stove-related articles—have consistently conducted the most thoughtful, well-balanced and scholarly research that I've seen to date in the world of outdoor journalism.

Their high-quality, in-depth analyses of a wide range of backcountry-related subjects has made my \$24.99 annual subscription fee seem like a great bargain (by the way, I have no affiliation with BPL other than as a standard subscriber).

2. Jason Klass is a fellow backpacker who took an early interest in the Super Cat stove and has developed a number of his own modifications and enhancements. I'd encourage you to visit his [nicely-designed website](#).
3. Zen Seeker has volunteered a great deal of time and energy to develop one of the Internet's "go-to" sites for reliable information about backpacking stoves and related subjects. The [Zen Stoves website](#) is cited multiple times above and is a terrific resource for any do-it-yourself stove builder.

USER FEEDBACK

Ever since placing its design concepts into the public domain in 2005, I've considered the Super Cat to be a work in progress and have actively encouraged users to develop their own modifications and improvements.

Over the years, great numbers of Super Cat enthusiasts have been generous enough to provide feedback, primarily in the form of emails and online bulletin board postings. Many of these insights remain accessible through the Base Camp feedback forum (link below).

My hope now is that this updated article, along with the concurrent introduction of the companion Fire Bucket system, will stimulate a renewed wave of user-based development.

If you take an interest in the Super Cat, please report back through the feedback forum on your experiences and recommendations. This "open source collaboration" (to borrow a phrase from the software industry) will strengthen the design for all of us.

[You can submit or read comments about this article here.](#)

CONTACT ME

If you'd like to contact me directly, [please do so here](#).

[Top](#)

[Home](#)

Copyright © 2005 – 2008 James E. Wood. All Rights Reserved.