



A windscreen plus wood stove for about two ounces

The Fire Bucket Stove System

By Jim Wood

Published November 18, 2008

Last revision April 6, 2009

[Printable PDF version available here \(1.1mb\)](#)

[Submit or read comments about this article here](#)

[Home](#)

[Feedback forum](#)

This article discusses a new high-performance windscreen for alcohol stoves that can also serve as an efficient, stand-alone stove for burning wood and solid-fuel tablets. In its lightest implementations, it weighs only about two ounces. The Fire Bucket can be constructed from a variety of inexpensive, easily-obtained materials in either collapsible or permanently assembled models using simple tools.

Also of note is the concurrent publication of a new article about a companion product, the [Super Cat Alcohol Stove](#). First shared with the backpacking community in January, 2005, the original article has been completely rewritten to incorporate many of the design ideas that Super Cat users have contributed over the years, as well as to expand the scope to include new information about fuels, windscreens, stands and other accessories.

When used together, the Super Cat and Fire Bucket form an efficient, lightweight, integrated stove system that's easy to make and fun to operate.

You can navigate directly to each chapter using the links below.

<p>Background</p> <p>The Fire Bucket Design</p> <p>Disclaimers and Safety Notes</p> <p>Materials</p> <p>Tools</p>	<p>Build Instructions</p> <p>Usage Notes</p> <p>Accessories</p> <p>Tips and Tricks</p> <p>Resources and Feedback</p>
---	--

Background

Over the past decade or so, a great many backpackers, especially those who engage in long-distance hiking, have developed an affection for alcohol and tablet-based stoves because of their simplicity, light weight and availability of fuels at re-supply points.

As the developer of the [Super Cat alcohol stove](#)—which has become one of the most popular do-it-yourself alcohol stove designs among hikers worldwide—I find it curious, however, that so much of the online discussion about these devices seems to focus on the stoves themselves, rather than the larger issue of cooking system performance. I use the word "curious" since the advantages of one stove design over another, which are usually discussed in the context of laboratory-like conditions, are often completely lost when it comes to real-world trail use.

The biggest problem, of course, is the wind.

Wind is public enemy #1 for any backpacking stove system, but because of their low flame velocities, alcohol and tablet-based stoves are particularly susceptible to the disruptive effects of air movement. Unprotected from even a slight breeze, these stoves can quickly become unusable.

To date, the most widely adopted design that attempts to solve the wind problem is a sheet metal windscreen that includes a row of ventilation holes around the bottom.



Traditional aluminum windscreen (+)

It's been my experience, however, that most implementations of this windscreen design don't perform very well and that additionally, many are a hassle to use. So much so, that according to a fair number of the participants in the discussions noted above, windscreen issues have soured them on using alcohol or tablet-based stoves at all.

WINDSCREEN PROBLEMS

In my 2005 article (updated in 2008) entitled [Build Your Own KiteScreen](#), I highlighted some of the problems associated with traditional windscreens that I'll repeat here:

- Because they're not anchored to the ground, most windscreens can blow around in even moderate winds. If one side happens to get pushed too close to the stove's flame, a portion of the windscreen can melt.
- Most windscreens cover only part of the cook pot. As a result, some of the wind that strikes the pot from the sides is deflected downward towards the stove (inside the windscreen), causing turbulence in the flame below.
- Metal windscreens placed close enough to a stove to be really effective can get quite hot during operation, creating a burn hazard for the user. Because a pot's handle often ends up very near an edge of the windscreen, skin-to-windscreen contact is almost inevitable with some designs. Likewise, these hot windscreens are also great for melting the synthetic fabrics used in expensive outdoor clothing.
- Most traditional windscreens must be unrolled, or unfolded and flattened and

assembled before deployment, which can make them a hassle to use.

- Many windscreens, particularly those designed for use with alcohol stoves, must be populated with multiple ventilation holes in order to provide pathways for oxygen to reach the stove's flame. These same holes, however, can also allow the wind to create turbulence inside the combustion area, thereby reducing the stove's efficiency (sometimes by a lot).

This last point is the probably the most important, in my opinion. Unless fairly large in size, the ventilation holes used in most of these designs can offer a fair amount of resistance to air entering the windscreen, which can starve a flame for oxygen. If the holes are large enough to permit the free flow of air, then they probably also contribute to internal air turbulence when the wind blows.

SOLUTION ALTERNATIVES

One approach to solving some of these problems, discussed in my [KiteScreen article](#), is a fabric or film-based screen that's anchored to the ground and that's large enough to protect the entire cooking setup. This design works particularly well for top-mounted canister stoves that are otherwise difficult to safely shield from the wind.

Another is to integrate wind protection into the stove design, rather than treating it as an afterthought. Examples of products now available in the canister stove market include the Jet Boil and MSR Reactor systems, both of which work well but which are too heavy and expensive for many. In the commercial alcohol space, the Caldera Cone systems from Trail Designs seem to have gained a following, though the cones can be difficult to store, and the titanium version that permits cooking with wood is very expensive.

The purpose of this article to suggest an integrated, do-it-yourself alternative that overcomes many of the problems associated with traditional windscreens. I call the design the "Fire Bucket" since my early prototypes were made from coffee cans that were bucket-like in appearance.

And as a bonus, the Fire Bucket can serve not only as a high-performance windscreen for almost any kind of alcohol heater, but also as a stand-alone stove that can burn Esbit/Hexamine tablets, wood, coal or almost anything combustible, all at a weight of about two ounces (at least if constructed from aluminum as described below).

Disclaimers and Safety Notes

Before proceeding, I should point out that I am not a chemist, nor an expert in stove technology. I am just a backpacker who has struck upon something interesting that I feel is worth sharing with my fellow hikers.

All experienced outdoors people already understand that any stove is potentially dangerous and should be handled with care, especially when operated in the vicinity of a tent or tarp. Besides presenting a fire hazard, many stoves (including alcohol stoves) can also emit fair amounts of carbon monoxide which can be deadly if concentrated in closed spaces.

If you decide to build your own Fire Bucket, you must assume all risks. I obviously can't guarantee your safety nor indemnify you against accidents. I would, however, warn you not to attempt to use this design with petroleum-based fuels such as automotive gasoline, kerosene or white gas (Coleman fuel).

These fuels are much more volatile than are alcohol and are dangerous to burn in open containers. Petroleum vapors can quickly pool in low-lying areas, especially within the confines of the Fire Bucket walls, and can explode when exposed to flame. And besides,

these fuels work very poorly in unpressurized stoves.

I should also mention that while someone else in the backpacking community may have developed a similar design, I've not found it through the Internet searching I've done to date. Nonetheless, if you're out there and reading this article, I apologize for the lack of attribution, but note that I have arrived independently at all of my conclusions.

The Fire Bucket Design

When I recently began working on an update to the original Super Cat alcohol stove article (which was published almost four years ago), it became clear that developing a better solution to the wind problem was essential. The original article simply pointed users to the Internet for windscreen designs that were created by others, mostly ignoring the fact that wind protection was actually more important than many of the mechanical details of the stove itself.

Needed was the same kind of integrated approach that's been adopted over the past few years by the canister manufacturers mentioned above that would hopefully produce a system that would be lightweight and simple for backpackers to build and use.

DESIGN CHANGES

After a fair bit of trial-and-error, it occurred to me that making two simple changes to the traditional windscreen could not only satisfy my design criteria, but would also enable some interesting new capabilities.

Change #1

The first change would be to elevate the burn platform above ground level so that the stove flame would no longer be directly in line with the air that's entering the screen through ventilation holes. Doing so would help to isolate the stove in a quieter air space above the inbound air, thereby reducing internal turbulence.

If this elevated platform were also constructed of an open, grate-like material, incoming air could pass easily through it from below, allowing it to be evenly distributed around the outside of the stove, improving burn efficiency. In addition, raising the stove would also largely eliminate the performance-robbing conductive heat losses to the cold ground that can happen when an alcohol stove is used in chilly weather. Elevation also helps protect the vegetation or other surfaces beneath the stove.

Change #2

The second change would be to replace the multiple small ventilation holes found in traditional designs with a single large opening that could be positioned on the downwind (leeward) side of the stove. A single large port would virtually eliminate the incoming air resistance that's frequently discussed in connection with small vent holes. It would also make it easier to throttle airflow in order to control heat output, as well as to better manage turbulence inside the screen using the techniques discussed below.

Additionally, this large ventilation port could make it safer and more convenient to light wood, fuel tablets, and many types of alcohol stoves. Rather than having to reach over the top of the screen and into the burn chamber with a lighted match, a user could start the fire or light the stove from the bottom through this opening.

Change Produces Synergy

The combination of these two changes would also permit a design that could serve not only as a windscreen, but also as an efficient stand-alone stove for burning solid-fuel tablets and wood. It would do so largely by optimizing the "chimney effect", where cool air would enter the combustion chamber from below, pass freely up and around the burning fuel to infuse

the flame with oxygen, would be heated, and then would flow around the bottom and sides of the cook pot to help transfer thermal energy.

Without getting into implementation details quite yet, you can get a sense of the basic design idea by viewing the brief animation below, created using [Google SketchUp](#).

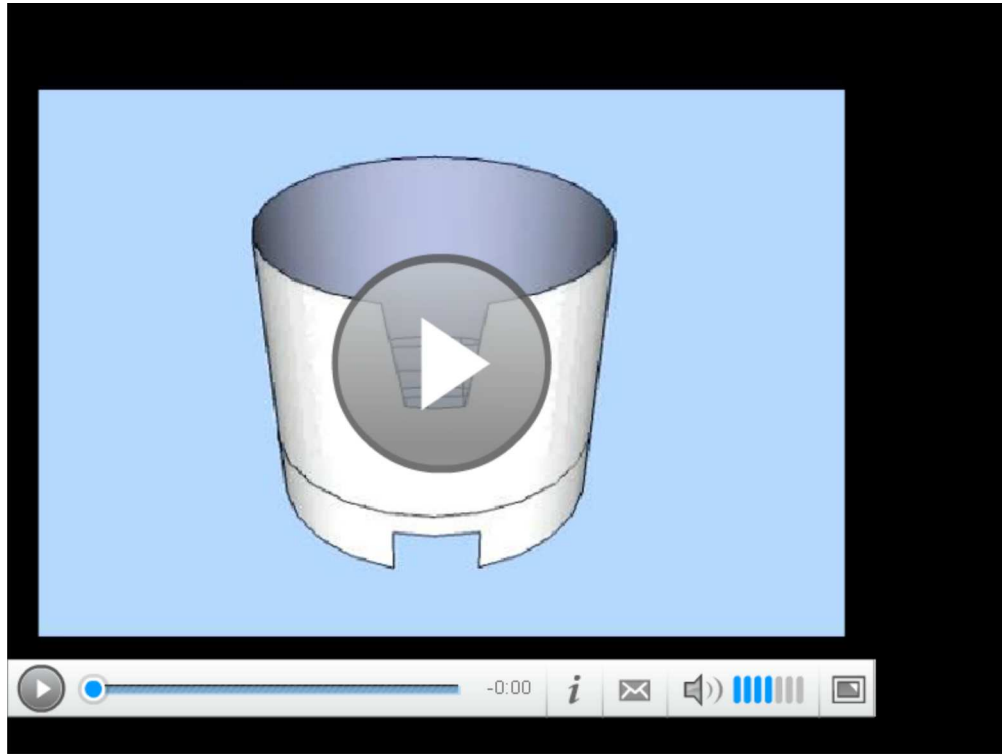

By the way, if the Flash player window above doesn't appear in your browser, or if you're otherwise unable to stream Internet video, you can download an [AVI version](#) of the animation. Likewise, if you're a SketchUp user, you're welcome to download a copy of the [SketchUp model](#) itself.

IMPLEMENTATION OPTIONS

It turns out that a windscreen / stove combination that incorporates these two design changes can be built using a wide variety of materials and construction techniques, allowing a builder to tune the design to precisely fit his or her needs.

For example, a Fire Bucket can be either permanently assembled or collapsible, can be constructed from several metals including aluminum, steel, titanium, brass or copper, and can employ burn platforms that are either attached, removable, or even that "float" independently inside the enclosure. It can also accommodate a number of optional accessories (discussed below) that allow for further customization.

For me, weight is important, so I want a unit that's as light as practical. I also want it to be constructed from widely available, inexpensive materials that are easy to work with. The ability to store it in either an assembled or in a collapsed configuration is also a plus.

Accordingly, the specific implementation that I'll use to illustrate the Fire Bucket design will be as pictured below. As I describe this unit, however, I'll suggest other many other build options that you might want to consider.

JIM'S FAVORITE

Jim's favorite Fire Bucket is of a collapsible design, sized to fit the rather large (at least for solo use) Snow Peak Trek 1400 cook pot, and weighs about 2½ ounces. The photos below are of a unit that's been well-used with alcohol stoves, Esbit tablets and wood.

It's made from 6" wide aluminum flashing that can be purchased from most home supply centers in rolls as short as 10 feet for about \$4.00. I like this material because it's lightweight, readily available, easy to work with, and is heat resistant enough for this task. For more about aluminum flashing, see the [Materials](#) section below.

The two ends of the flashing overlap 5/8" and are connected to form a cylinder using three small brass screws with wing nuts that pass through drilled holes, allowing the screen to be easily disassembled (it can be transported either assembled or collapsed).



Front view (+)



Rear shows assembly bolts (+)



Top view shows burn platform (+)

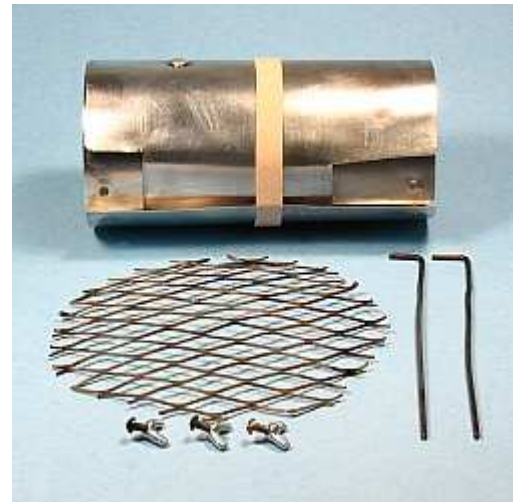

Disassembled for transport (+)



Shown with optional wind shade
(see [Accessories](#) section below) (+)



Shown with optional floor
(see [Accessories](#) section below) (+)

The burn platform is made from lightweight steel mesh cut with tin snips from a drip grate that's used on top of paint roller trays (available from Wal-Mart for about \$2.50). See the burn platform [Materials](#) section below for more info.

The platform is supported 1½ inches above ground level by two removable rods that are constructed from heavy-duty coat hangers and that run through four small holes punched in the sides of the screen. There are four other small holes near the top of the screen that will accept two thin titanium stakes that are used as pot supports when burning solid-fuel tablets or wood (coat hanger rods work just as well here too).



Pot on rests on Super Cat alcohol stove (not shown) (+)



Pot rests on upper supports for wood burning mode (+)

The single ventilation hole is 1 inch high and 1½ inches wide. Both this opening and the pot handle opening were cut into the flashing using ordinary household scissors.

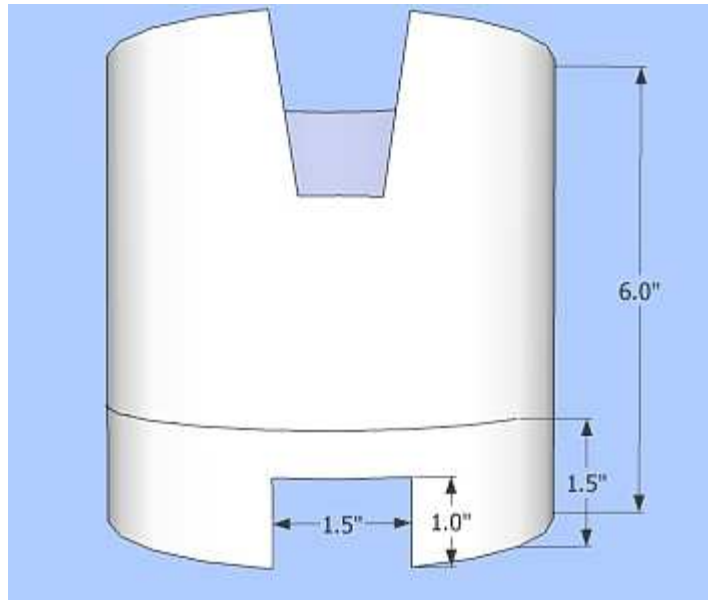

Jim's favorite Fire Bucket
key dimensions (+)

A similar unit built for the MSR Titan Kettle, is permanently assembled using aluminum pop rivets and incorporates a burn platform constructed from picture hanging wire (the technique is described below). It weighs 1.7 ounces. A slightly larger version of the same design built for the Snow Peak Trek 1400 weighs 2.0 ounces.



1.7 oz permanently assembled model for MSR Titan Kettle is fastened with flattened pop rivets (+)



The burn platform of this model is constructed from 22 gauge steel picture hanging wire (+)

Materials

WINDSCREEN PORTION

Aluminum Flashing

As noted above, aluminum roof flashing is a good all-around material for Fire Bucket screen

construction. In most cases, the 6" wide version of the widely available Amerimax product called "Economy Aluminum" (product #68306) should suit your needs.

It's about 9 mils thick when new and about 8 mils thick—according to my vintage micrometer—after the coatings have been removed (coatings are discussed below). Amerimax also offers similar flashing products in other thicknesses, widths and metals. See the [Amerimax website](#) for more information.



6" wide aluminum flashing



Also available in other widths, thicknesses and metals

While aluminum flashing generally offers a good mix of properties for use in Fire Buckets, there are a couple of issues.

The first is that both sides of the aluminum (at least with the Amerimax product) are coated with a polymer that's intended to protect the bare metal from weathering when installed in a roofing environment. The first few times you subject the windscreen to the heat of a stove or the flame of a wood fire, this coating will begin to burn away.

Because of the smoke and toxic smell, you'll want to make sure your first few burns are conducted outdoors and not inside your home. I learned this fact the hard way by filling my basement with acrid fumes and activating a smoke detector during an early burn.

Though it's possible to sand this coating off before initial use, doing so is difficult. So instead, I'd recommend subjecting the flashing to a couple of pilot burns, after which you'll note the coating will probably have turned brown or black and will also have cracked or flaked in spots. At this point, it will be fairly easy to remove using a steel wool soap pad, such as Brillo or SOS.

The photo below is of a sample of aluminum flashing that's been subjected to such heat exposures. The left side shows the burned coating, while the right shows the result of a brief cleaning with a steel wool pad.



Heated aluminum flashing (+)

Left side shows burned coating,
right side cleaned with steel wool.

The second issue is that 9 mil thick aluminum is pretty heat resistant, but is not completely immune to melting or warping. In exchange for the weight savings, you'll need to be somewhat careful with this material, especially when building wood fires. In my experience, small-to-moderate wood fires are fine and will easily boil a couple of cups of water without causing damage to the aluminum.

If you're inclined to make bonfires, however, or if you intend to use the unit primarily as a wood burner, you'll probably want to skip aluminum and build your Fire Bucket from a more heat resistant material such as steel or perhaps even titanium.

Steel Cans, Rolls and Sheets

Steel is a great material for Fire Buckets, though it can be a little heavy, especially when building for larger pot sizes. The steel that's used in many food cans, however, is often thin enough that you may find its weight acceptable.

Coffee or large fruit juice cans are a good way to start and were the basis for my early prototypes. Because a can is already assembled into a cylindrical shape, it makes construction somewhat easier if you're OK with a non-collapsible design. The metal used in most cans with which I've experimented ranges from 8 to 12 mils thick, which makes it pretty much melt-proof with normal use.

With a pre-formed can, of course, you'll not be able to adjust the Fire Bucket's diameter to fit around a particular cook pot with the precision that's possible with flashing or sheets cut to an exact length. On the other hand, it's usually possible to find cans that are sized close enough for the purpose.



For example, my local Safeway grocery store stocks steel coffee cans that are available in a 13 ounce size that fits the Snow Peak 600 titanium mug well, a 26 ounce size that fits the MSR Titan Kettle, and a 34.5 ounce size that works with the Snow Peak Trek 1400 pot.



Small coffee can model fits the Snow Peak 600 titanium mug and weighs 3.1 ounces (+)



This large coffee can model retains its steel bottom and fits the Snow Peak Trek 1400 (+)

The finished weights of Fire Buckets constructed from these cans will probably vary from about 3 ounces for the smaller sizes to over 9 ounces for the largest, depending on construction techniques and other materials used. The large model shown above retains the bottom and is the heaviest of my prototypes at 9.6 ounces and though somewhat hefty, makes a great full-time wood stove.

Compared with weights of 1½ to 2½ ounces for aluminum models, these numbers may seem high, but compared with the 8+ ounce base weight of a typical top-mounted canister stove system*, they don't seem so bad considering that you get a windscreen and a wood-burning stove included in the deal.

Steel is also available as flashing in rolls and as galvanized sheets for use in HVAC ductwork. It's usually about 12 mils thick in these forms, which would yield Fire Buckets of about the same weights as those made from large coffee cans.

One advantage of starting with rolls or sheets, however, is that the material can be cut to precisely the desired dimensions and be used to create either permanently assembled or collapsible Fire Buckets. One such prototype, made from galvanized sheet steel, and built again for the Snow Peak Trek 1400 pot is shown below and weighs 6.5 ounces, complete with burn platform.

Important Safety Note: Galvanized steel is coated with zinc, which can be vaporized at temperatures above its boiling point of 1665° F. If inhaled in sufficient quantities, the resulting zinc oxide vapors can induce flu-like symptoms that are associated with a condition sometimes called "metal fume fever".

This condition is usually discussed in the context of welders who regularly work with galvanized steel at high temperatures (typically, much above zinc's boiling point) and while the symptoms can be unpleasant in the short-term, the condition is generally thought to produce no long-term health problems.

Because most of the small wood fires built in Fire Bucket stoves are unlikely to produce

enough heat (perhaps reaching 800° to 900° F) to actually vaporize the zinc coating, I suspect that galvanized steel is probably OK for this application, even though there may be some melting of the zinc (which can occur at 787° F) as seen in the photo below.

The same appears to hold true for use with most alcohol stoves, which seem to produce even less of a heating effect on the walls of the Fire Bucket that do the wood fires I've built (I can, however, produce no hard data to confirm these observations).

Nonetheless, if you elect to construct a Fire Bucket from galvanized steel, I'd suggest that to be safe, you conduct your first few burns outdoors in a well-ventilated area and avoid breathing any of the smoke or fumes produced. I've found that after a few uses, there appears to be no continuing effect of the heat on the galvanized coating, though of course, I can make no guarantees about this material's long-term safety.

For more information, see the [U.S. Department of Labor's OSHA website](#) or conduct an Internet search for terms such as "zinc welding safety".



**Large galvanized steel model
for Snow Peak 1400 weighs 6.5 oz (+)**

* Assuming 3 ounces for the stove and 5 ounces for an empty 8 ounce fuel cartridge, without a windscreen.

Titanium Sheets and Pots

Titanium is also an excellent material for Fire Buckets, since it can be as light as aluminum, but as strong and heat resistant (or more so) than steel. In sheet form, however, it's hard to buy in small quantities and is very expensive.

Nonetheless, if the combination of durability and light weight were really important, one approach could be to purchase an existing titanium cook pot that was large enough to serve as a Fire Bucket for a smaller pot that fit inside, and modify it accordingly. Note, however, that titanium can sometimes be difficult to cut and drill.

Other Metals

Brass and copper sheet metal are also options, but both are fairly expensive and don't seem to offer any compelling advantages over the other materials discussed above, so I'd probably bypass them unless cosmetics are important to you.

MATERIALS: BURN PLATFORM PORTION

As used in Jim's Favorite Fire Bucket that's described above, a burn platform can be constructed by cutting an appropriately-sized section of steel mesh from a drip grate that's used on top of paint roller trays, widely available for \$2.00 to \$3.00 from sources such as Wal-Mart or Home Depot.

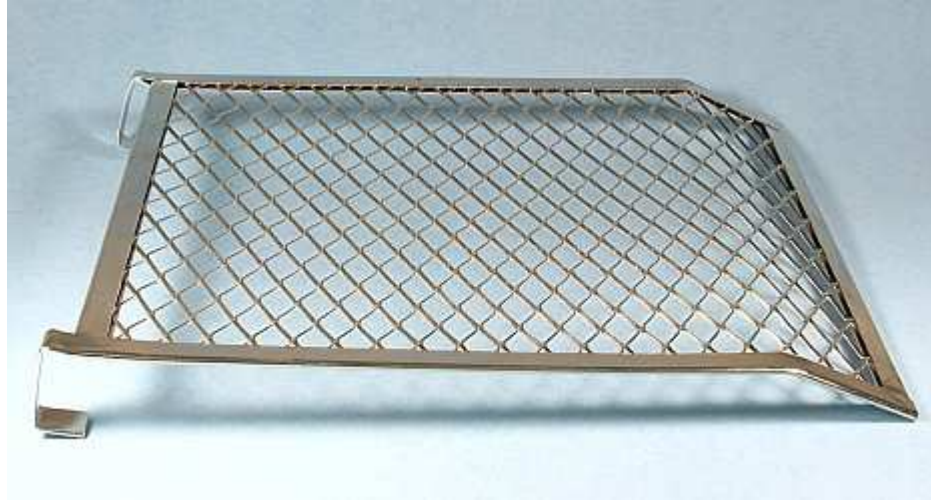

Paint roller drip grate from Wal-Mart (+)

One alternative is to use what's called "hardware cloth", which is really just another type of wire mesh that's available in a range of sizes and material types. The downside of hardware cloth is that you'll probably to purchase a larger quantity than you'd ever need for one (or even a few) Fire Bucket projects. I did find one [online vendor](#), however, that sells sample-sized quantities of many of its wire mesh products in 6" x 6" swatches.



Welded mesh from [TWP, Inc.](#) (+)

Another option I like for permanently assembled models is to create a burn platform using picture hanging wire. I'd suggest 22 gauge solid steel wire (rather than stranded, which is heavier and more difficult to work with) that's available in 100 foot reels from sources such as Home Depot for about \$2.50. The process for installing this wire to create a burn platform is described below.



Steel picture hanging wire (+)

Tools

The tools required to build a Fire Bucket will depend upon the design and materials you elect to use, but are mostly pretty simple.

Basic Tools

Aluminum flashing models are the easiest to build since the metal can be cut with a sturdy pair of household scissors. Also helpful are an awl for making holes, needle-nosed pliers, a felt-tipped pen for marking hole and cut positions, and a ruler for measuring.



Basic tools for aluminum flashing models (+)

Other Tools

If you cut the burn platform from a section of paint roller grate, or if you build your Fire Bucket from steel or titanium, you'll need a pair of tin snips and/or sturdy wire cutters.

Likewise, besides an awl, holes can also be made with an electric drill or a with handheld sheet metal punch. If you don't already own one, an inexpensive sheet metal punch is a

great investment for avid do-it-yourselfers. Also known as "Whitney" punches, they can be purchased for as little as \$20 plus shipping from online sources such as [Harbor Freight](#), that offers both [standard](#) and [deep throated](#) models. I'll note too that these punches are very handy for building Super Cat alcohol stoves.

If you build a permanently assembled Fire Bucket, a good way to join the ends is with short pop rivets (also known as "blind rivets"). You can use aluminum, steel or copper rivets but aluminum rivets are the easiest to hammer flat to reduce their profile as described below. Handheld rivet installers are also inexpensive, available from a wide range of sources (such as [Harbor Freight](#)) and are a great addition to any tool box.



Other useful tools might include an electric drill, a handheld sheet metal ("Whitney") punch, a pop riveter, a metal file, and a pair of tin snips (+)

And finally, in instances where you're cutting a ventilation hole in a steel can where the bottom has been left in place (more below on this option), it may be necessary to make the cut using a handheld jigsaw equipped with a metal cutting blade (not shown).

Build Instructions

Note: There are so many ways to build Fire Buckets that it's not practical to discuss each in detail. So instead, I'll describe a few basic materials and techniques, then allow you to exercise your creativity and fill in the gaps. You can skip directly to the desired subsection using the links below.

[Building the Screen \(Flashing or Sheet Method\)](#)

[Building the Screen \(Steel Can Method\)](#)

[Cutting the Pot Handle Opening](#)

[Building the Burn Platform](#)

[Building Pot Supports](#)

BUILDING THE SCREEN (Flashing or Sheet Method)

Material Width

If you construct your Fire Bucket from aluminum flashing, you'll probably find that the 6" width will adequately protect your cook pot while also allowing sufficient room for an elevated burn platform.

If you need more width, however, flashing is also available in 8", 10", 12" and 14" (or greater) sizes with, of course, correspondingly greater weights. Alternatively, you could join two pieces of 6" wide flashing lengthwise with machine screws or pop rivets to create (assuming about ½" overlap) a screen that's up to 11½" high.

Another choice, if you'd like more height only some of the time (perhaps only in very windy conditions), you might want to build an optional height extender, as discussed in the [Accessories](#) section below.

Fitting and Measuring

While it's possible to build a single Fire Bucket that can be used with pots of multiple sizes, it's usually most efficient to optimize the fit for a single vessel.

The easiest way to measure the length of the material you'll need is to cut a section slightly longer than necessary, then wrap it around the target pot to tune the fit. Normally, you'll want ¼ to ½ inch clearance between the pot and the screen, though in practice what usually happens (especially with aluminum flashing) is that the heat from the flame will distort the screen so that there will be little or no clearance in some spots and extra clearance in others.

Another factor to consider is how you'll transport your Fire Bucket when not in use. If you use a pot cozy, for example, you may want to allow for its width if you intend to nest your cook pot inside the cozy which will in turn, nest inside the Fire Bucket for carry purposes.



This unit has been sized to allow room for a pot cozy nested inside during transport (+)

Once you've established a diameter, you'll want to add approximately 5/8" to your total cut length for overlapping the two ends to make a cylinder. Once cut, you can then join the ends in several ways, depending upon whether you want to build a collapsible or a permanently assembled screen.

Joining the Ends

For collapsible models, I'd suggest bypassing most of the techniques you may have either

read about or employed in the past for joining aluminum windscreen ends, such as using paper clips, office binder clips, and the like. The problem is that most traditional windscreens are not weight bearing, so if they pop apart during use, no big deal.

Most implementations of the Fire Bucket, on the other hand, will be weight bearing since they'll need to support your stove (or wood fire) and a pot full of water while in operation. You will most definitely NOT want the unit to disassemble itself when subjected to heat and wind stresses during operation, possibly spilling burning fuel, scalding water or your dinner-in-progress on you and your surroundings.

Accordingly, I'd suggest a more robust approach and join the ends of collapsible models by first drilling or punching three small holes in the overlap zone (one in the middle and one near each end as shown below), then using three small machine screws with either standard nuts or wing nuts to complete the union.

The nuts need only be hand tightened when assembling and the use of additional hardware such as flat or lock washers is probably unnecessary. Even if the nuts happen to loosen a bit during operation, it's highly unlikely that the entire screen would ever pop open with this approach.

For permanently assembled models, either 3 or 5 small machine screws (this time well tightened perhaps installed with flat and lock washers) or pop rivets work well.



This collapsible model uses machine screws and wing nuts (+)



Permanently assembled model fastened with pop rivets (+)

If you'll be storing a pot cozy inside the Fire Bucket for transport, you'll want to minimize the profile of your chosen fasteners inside the screen to reduce the chance of snagging the side of the cozy when it's inserted. You'll therefore want to position the heads of small machine screws on the inside (rather than outside) of the screen. To further reduce their profile, you can also file the heads down, if desired.

If you use pop rivets as fasteners, one trick is to position the head on the outside surface, install the rivet, then flatten the inside portion using a hammer on the inside and a hard surface (such as the anvil portion of a bench vise) on the other.

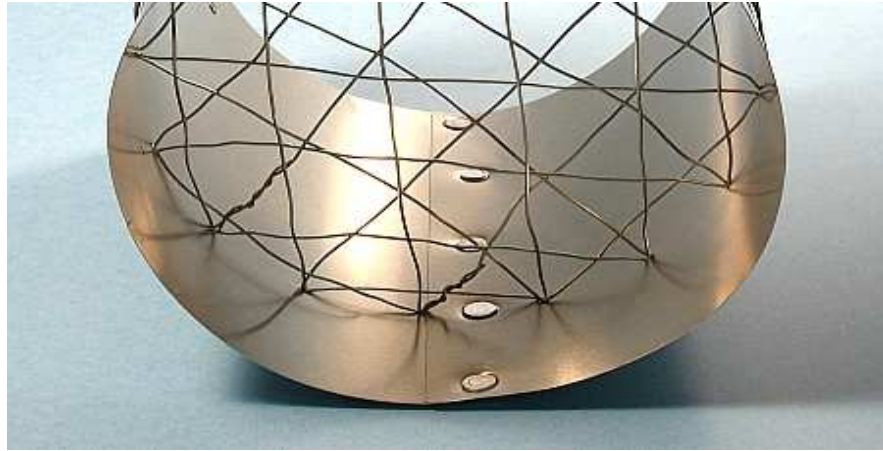

Inside shows rivets flattened with a hammer prior to installing the burn platform (+)

If you flatten the rivets (easiest with aluminum rivets, more difficult with copper or steel), you probably won't need backing washers. If you'd prefer not bothering with flattening the rivets, then you'll probably want to install the heads on the inside of the screen with backing washers on the outside surface (especially with aluminum flashing). In any case, I'd suggest testing your rivet technique on metal scraps before proceeding with your build.

BUILDING THE SCREEN (Steel Can Method)

Removing the Bottom (or Not)

Constructing your Fire Bucket from an empty steel can involves some of the same techniques as used for a screen made from flashing. One difference, however, is that you'll have to decide whether or not to remove the bottom from the can.

While doing so can save a bit of weight (perhaps $\frac{1}{2}$ to 1 ounce), leaving the bottom in place has some advantages. The bottom joins the can walls with an hermetic seal that can improve control over airflow inside the screen compared with open-bottom models. It can also serve as a heat reflector, bouncing much of the radiant energy that would otherwise be directed towards the ground back up towards the cook pot. Further, it can protect the surface under the Fire Bucket and serve as an ash collector for wood fires.

When the Fire Bucket is used with some types of alcohol stoves (like the Super Cat), the metal bottom can serve as a priming pan, which also allows stove ignition without having to reach over the top edge of the screen and into the interior with a lighted match. The technique, which is described in greater detail below, involves a dribbling a little of alcohol down one side of the stove and onto the bottom, where it can be ignited through the large ventilation opening. The alcohol that burns briefly on the bottom surface will warm the aluminum stove above, helping to accelerate the priming process.

I will note that some of these same advantages can be realized with open-bottom models simply by placing a few folded sheets of aluminum foil, or a lightweight aluminum disk (see the [Accessories](#) section below) under the Fire Bucket. In any case, should you elect to remove the can's bottom, you can usually do so with an ordinary household can opener. With cans that are sealed with foil tops, it may also be necessary to remove the inner ring (usually about $\frac{1}{2}$ " wide) using the same opener.

Cutting the Walls

As noted under the [Tools section](#) above, regular scissors probably won't be able to cut the pot handle and ventilation openings in a steel can, so you'll need either tin snips or a handheld electric jigsaw equipped with a metal cutting blade. Tin snips alone will probably suffice if you elect to remove the bottom, but if you decide to leave the can bottom intact,

you'll likely need a jigsaw to create the ventilation opening.

For this case, I'd suggest proceeding as follows: First, mark the desired position of the ventilation opening at the bottom of the can using a felt-tipped pen, then drill near each of the four corners of the rectangle with a bit large enough to accommodate the width of your jigsaw blade (see photo below).



3/8" holes drilled near the corners of the ventilation port (+)



Opening cut from hole-to-hole using a jigsaw equipped with a metal cutting blade (+)

Once the holes have been drilled, it should be fairly easy to cut the opening, moving from hole-to-hole with the jigsaw. While cutting, take care to keep the blade clear of the inside bottom surface, or you could accidentally cut through it.

Also, be sure to wear safety glasses and probably hearing protection, since cutting sheet metal with an electric saw can be rather noisy. When the cut is complete, rough edges can be smoothed with a metal file.

CUTTING THE POT HANDLE OPENING

Whether your screen is constructed from flashing, metal sheet or a steel can, you'll need to cut an opening to accommodate your pot handles. If you're building for a pot that doesn't use handles, such as the [FireLite SUL-1100](#) titanium cook pot from [backpackinglight.com](#), then congratulations, you're finished with the screen. Otherwise, you'll need to figure out how to size and position this opening.

I'm going to skip ahead here, because in order to determine the best dimensions and placement for this opening, you'll first need to decide what heating method you intend to use most of the time, and will also need to have completed both the burn platform and pot supports as described below.

To describe this simple process, I'll assume that you'll be using an alcohol stove as your primary heater. If you plan to use Esbit tablets or wood, then you'll need to adjust accordingly.

1. First place the stove in the center of the burn platform. If you'll be using an optional stove holder ([see below](#)), you'll probably want to include it as well, though its effect on pot height will likely be minimal.
2. Next, position your cook pot on top of the stove (or pot supports if appropriate) with the handles collapsed and observe where the pot handles, when extended, will

intersect the Fire Bucket walls.

3. Using a ruler and felt-tipped marker, measure and mark an appropriately size opening and make the cut. If working with flashing, the bottom corners should be easy to manage with scissors. If working with steel, however, it may help to drill holes in the bottom corners and to use the other steel-cutting techniques that are [described above](#) in connection with the ventilation opening.
4. Finally, snip off or file sharp corners and edges as necessary.

BUILDING THE BURN PLATFORM

Collapsible Models

For collapsible Fire Bucket designs, the elevated burn platform will need to be removable. Such platforms can either be attached to the Fire Bucket via some form of removable support (perhaps as shown below) or can be "free floating" and supported independently of the surrounding screen.

One example of a attached (but removable) platform is shown in connection with Jim's Favorite Fire Bucket [discussed above](#). It uses a section of wire grate that's been cut from a paint roller drip grate purchased from Wal-Mart.

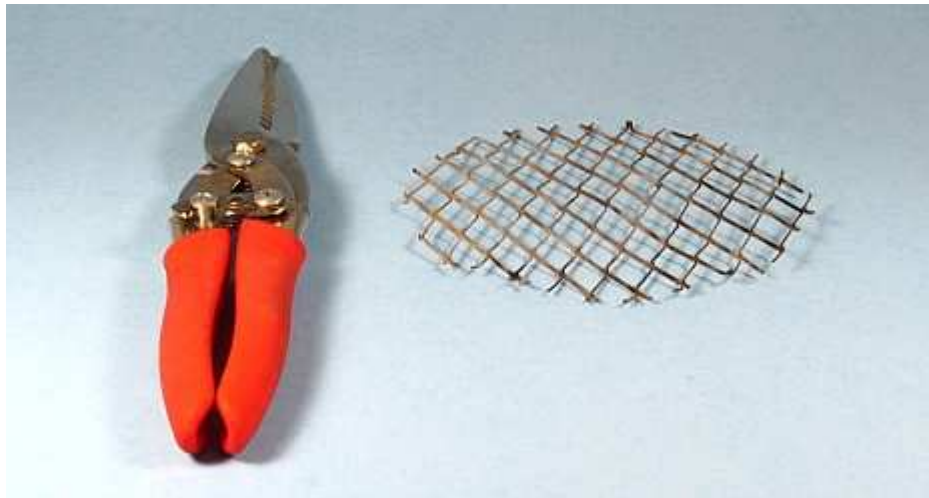

Paint roller grate section cut to size using tin snips (+)

For creating a free-floating platform, one option would be to plant three thin stakes into the ground as shown below, then simply rest the burn grate on top. This option might be appealing if you'd like to convert an existing windscreen into a Fire Bucket-like model.



**"Free floating" burn platform
supported by 3 titanium tent stakes (+)**

The stake approach obviously wouldn't work on a hard surface like a picnic table or rock slab, so some other type of stand would be needed for these situations. If using a stove like the Super Cat, that burn platform stand would also need to be fairly sturdy since it would have to support the weight of a pot full of water during operation.

Another option is to suspend the burn platform inside the screen using a sling that's constructed from stranded picture hanging wire. This technique is the same as that discussed below in connection with building a [sling-type pot support](#).

Permanently Assembled Models

If you're building a permanently assembled model, you can position a mesh grate on top of permanently installed support rods, perhaps attached to the rods by twisting small lengths of picture hanging wire around the two components in 3 or 4 locations. Permanently installed support rods can look just like the temporary rods shown above, except with the straight ends bent so that they can't slip back through the bucket.

Another lightweight approach is to construct the burn platform entirely from the 22 gauge, solid steel picture hanging wire that's described above. To do so, you can drill or punch tiny holes at 1 inch intervals around the perimeter of the screen at a distance of about 1½ inches above the ground, then run a length of wire from one hole to another, much like stringing a tennis racket.

The burn platform in the unit below was constructed in such a way by creating two independent grids: the first by running the wire in the vertical and horizontal directions; the second by adding an overlay of wire running at right and left diagonals.



**Burn platform created by stringing
22 gauge steel picture hanging wire
among tiny holes punched 1" apart (+)**

A hybrid method would be to first construct a minimal grid from picture hanging wire, then layer a paint-roller grate onto top of it, again perhaps securing it in place by twisting small lengths of picture hanging wire around the two components in three or four locations to keep them together. You'll just want to make sure that your minimal grid is sturdy enough to safely support the weight of a pot full of water when subjected to the heat of operation.

BUILDING POT SUPPORTS

If you use your Fire Bucket only as a windscreen for a Super Cat alcohol stove, then you won't need separate pot supports. However, if you'd like to use it either with stoves that require separate supports, or as a standalone stove for burning solid-fuel tablets or wood, then you'll need some type of support positioned at an appropriate height above the flame.

Fixed Position Pot Supports

Probably the easiest way to create pot supports is by using either a pair thin titanium tent stakes such as those shown in the photos below (which are about 7 inches long and that weigh $\frac{1}{4}$ ounce each), or heavy-duty coat hanger wires cut to size and with one of the ends bent at about 90 degrees to prevent slippage through the holes in the screen wall.

The supports can be installed through small holes drilled or punched in the walls of the Fire Bucket. It's best to orient these holes on the sides of the screen (relative to wind direction) so that when they're not in use, a minimum of air is forced through these openings. If you'd like to have the option of positioning your pot at more than one distance above the flame, then you'll need to create a set of four holes for each position when using this method.

I'd recommend locating the holes that are used to support the cook pot in wood burning mode near the top of the screen at a height that allows your pot handles to be oriented away from the normal handle opening.

That's because flames from a wood fire will normally exit the bucket through this opening, which would otherwise cause your pot handles, if positioned normally, to become extremely hot. Keeping this opening clear while burning wood also creates a convenient feed hole for additional fuel.



During this test burn, flames from a wood fire exit the top opening directly onto the pot handles (+)



Supports located at a height that allows pot handles to face away from the normal opening when burning wood (+)

If you'd prefer to support your cook pot using a method that allows for continuous up and down height adjustments without having to drill a lot of extra holes in the Fire Bucket walls, two such methods are discussed below.

Continuously Adjustable Pot Supports (Stake Method)

Rather than using 2 thin titanium tent stakes running horizontally through holes in the Fire Bucket walls, you can use 3 such stakes positioned inside the screen, oriented vertically in a tripod formation, planted into the ground through the burn grate.

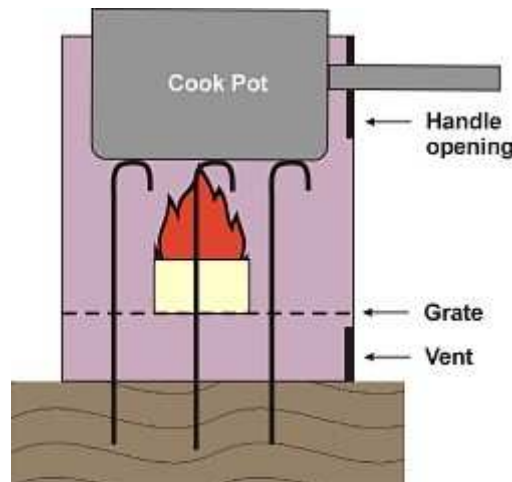

Side view shows pot supported by 3 tent stakes planted into the ground

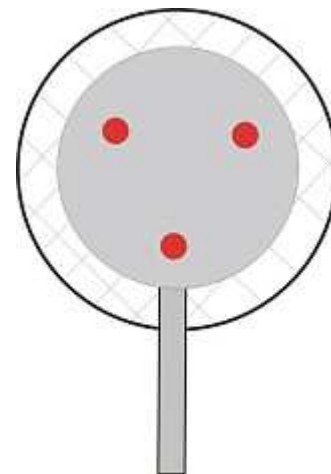

Top view shows stake positions (in red) relative to grate and pot

This method, of course, requires ground under the Fire Bucket that's firm enough to support the weight of a pot full of water on top of the three stakes, but assuming that condition is met, allows for continuous pot height adjustment through a range of about 3 inches without having to drill any additional holes in the bucket walls.

If your Fire Bucket has a floor of some type, you'd need to drill, punch, or poke 3 small

holes in that floor at the appropriate positions to allow the stakes to pass through in order to use this technique.

Continuously Adjustable Pot Supports (Sling Method)

Another way to position the cook pot at multiple heights above the flame is to suspend it inside the screen on a sling that's constructed from picture hanging wire. This method has the advantage of being usable anywhere since it's indifferent to the type of surface that's beneath the Fire Bucket.

To use this method, you'll need small four holes punched or drilled near the top edge of the screen in the same positions as those described above for use with the fixed supports positioned for wood burning. If these holes already exist, then the only other requirement is a piece of picture hanging wire 24" to 30" long.

For this purpose, I'd suggest using stranded wire, rather than the 22 gauge solid wire that's discussed above in connection building a burn platform. Because there will be only two segments of this wire supporting your pot full of water, and because this wire will be located above the flame (where it will be subjected to higher temperatures) rather than below it, you'll want the extra strength.

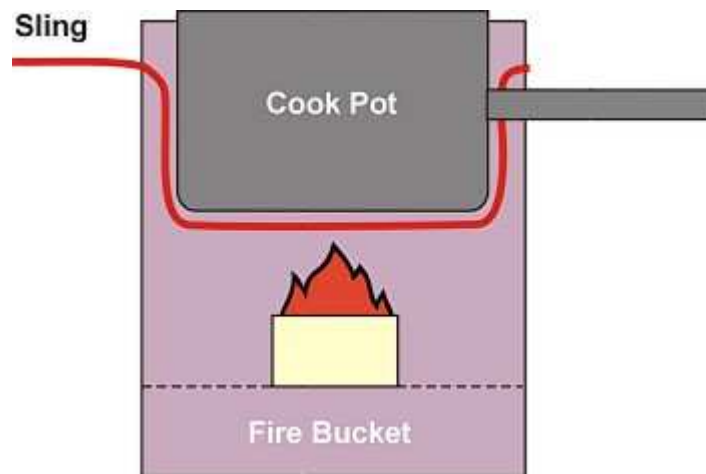

**Sling pot support (red line above)
made from stranded picture hanging wire**

When threading the wire through the holes as shown below, be sure to cross the wires in the center of the screen. If you don't, and the wires run in parallel to each other, the wires can (and probably will) slip from beneath the bottom of the pot to one side, allowing the pot to fall inside the bucket onto the flame.

To increase the depth of the sling, feed additional wire into the holes from the "working ends" of the wire (i.e., the loose ends shown at the bottom of the left diagram). You'll want to feed roughly equal amounts through each hole in order to keep the pot level inside. To decrease sling depth, just reverse the process.

Once the desired depth is reached, twist the loose ends of the wire together 2 or 3 times on the outside wall of the screen.

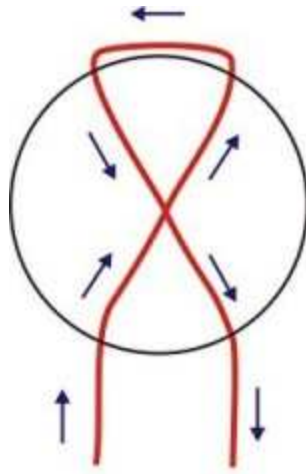

Thread the wire through the screen holes as shown in this top view

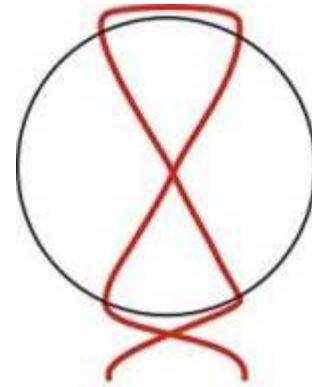

Once the desired sling depth is reached, twist the loose ends of the wires together 2 or 3 times

One issue with this type of support is that when a full pot is positioned near the top of the screen on the sling, the weight will tend to cause the sides of most aluminum flashing screens to bow inwards towards the pot. If the screen contacts the pot at too many points, very hot air can be trapped between the pot wall and screen, possibly causing the screen to warp or melt. The good news is that as the pot depth is increased, the weight forces become less horizontal and more vertical, which tends to mitigate this problem.

A more direct approach to the solving problem, which also improves the general stability of the sling support, is to layer a second grate of the same material used for the burn platform on top of the sling. The second grate should be large enough in diameter that it just fits inside the screen (as the burn platform probably already is). The uneven edges of this second grate will "lock into" the sling wires in a way that will both increase stability of this pot platform while also serving as a barrier to help keep the screen walls from bending inwards far enough to contact the walls of pot.



Top view shows sling suspended inside screen (+)



Side view shows twisted sling wires (+)



**Optional grate positioned
on top of sling to improve stability (+)**

The sling wire used in the examples above weighs about $\frac{1}{4}$ ounce, while the second grate adds another $\frac{1}{2}$ ounce. Since I mostly use a Super Cat alcohol stove (with perhaps some wood burning) I don't need additional supports very often. Even so, for the negligible weight, I usually carry the just the wire (and not the second grate) for those occasions where I might want to burn Esbit tablets and wish to support the pot at an optimal height.

Usage Notes

ALCOHOL STOVES

Filling and Lighting the Stove

It's probably easiest to fill most alcohol stoves outside of the Fire Bucket before lowering them into place inside the screen. I'll note here that a good way to keep the stove centered inside the screen is by using the [optional stove holder](#) that's discussed below.

After the filling operation is complete, you'll want to move your alcohol storage bottle and other flammables well away from the bucket before lighting the stove. Likewise, you'll want to use a safe ignition method (see below) that allows you to keep your face, hands and clothing well clear of any potential flare-ups.

Important Safety Note: One difference between the using an alcohol stove with the Fire Bucket when compared with using the same stove inside most traditional windscreens, is that with the Fire Bucket, the stove is started AFTER it's been lowered into the screen. With traditional windscreens, the stove is often placed on the ground first, primed and lighted, and then the windscreen is wrapped around the operating stove.

The significance is that with the Fire Bucket, alcohol vapors that evaporate normally from the stove in the time prior to ignition will often be contained inside the walls of the screen which can cause them to be more concentrated than they otherwise might be if allowed to freely disperse.

The result is that reaching your hand inside the Fire Bucket with a lighted match could trigger a flare-up that could singe hair or cause burns.

Therefore, when using alcohol stoves (or perhaps when using alcohol fuel to start help a wood fire), make sure that you use a safe ignition method.

One such method is to dribble a little alcohol down one side of the stove, allowing it to drip onto the bottom of the bucket. Having a piece of aluminum foil or an optional floor under open-bottom models, or the original bottom in place with steel can models is obviously desirable here. The stove can then be started through the ventilation opening by lighting the alcohol that's accumulated at the bottom of the bucket.

An alternative is to fill the stove, lower it into place inside the screen, then position a little tinder in the lower chamber of the bucket which can be ignited through the vent port. The flame from the tinder will rise to the stove, prime it, and in most cases, ignite the alcohol fuel (may not work for all stove types, but works well with the Super Cat).

Another choice is to use a long dry twig as a fireplace match. First light one end of the twig, then lower that end towards the stove through the pot handle opening or over the top edge of the bucket, keeping your hand outside of the screen wall at all times.

Finally, if you're using wooden matches, you might also want to try Jim's simple wine cork extender that's described in the "[Accessories](#)" section below. Likewise, for additional information about Fire Bucket ignition techniques in general, please refer to the "[Lighters and Matches](#)" discussion.

Lowering the Cook Pot

If you're using a Super Cat alcohol stove, you can lower your cook pot onto the lighted stove as soon as priming is complete and you can see bubbling on the surface of the hot fuel (usually 15 to 30 seconds after ignition). If you lower the pot straight down onto the stove, however, the flames may, for a moment, tend to be "squeezed" out through the pot handle opening directly toward your hand.

To avoid burns, simply tilt the handle side of the pot downward a bit as it's lowered. Doing so will cause the bottom of the pot to deflect the flames away from the handle opening and safely towards the back of the Fire Bucket during pot descent.

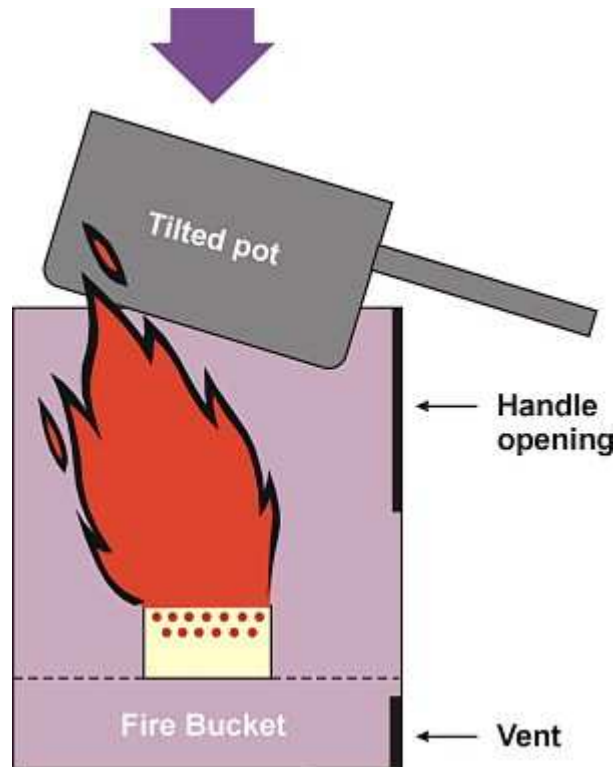

Tilting the pot slightly while lowering it onto the Super Cat will direct the flames away from the handle opening

If you're using an alcohol stove (or a wood / fuel-tablet fire) that requires separate pots supports, then you probably won't need to use this "tilt technique" and can probably lower the pot vertically into place.

Stopping the Stove

Most of the time, you'll just need to allow any alcohol remaining inside the stove after a cooking operation to burn itself out. In an emergency, however, you can use plain water to safely douse alcohol flames (unlike with petroleum-based fires, water won't just spread the flames around).

Because of the Fire Bucket's mesh burn platform, the use of a device like the snuffer cup (discussed in the Super Cat article) to smother the flames won't work without modifying the design. If stopping the stove by depriving it of oxygen is important to you, however, one solution would be to add a base around the stove holder that's wide enough to serve as a "smother platform" for the snuffer cup. See the [Accessories](#) section below for more discussion and construction details.

SOLID FUEL TABLETS

This one's pretty easy. Most of the time, you can just drop your Esbit or Hexamine tablet onto the center of the burn platform, make sure that your pot supports are securely in place, and then set the tablet ablaze.

You can light the tablet in several ways, but ignition from the bottom through the ventilation opening is probably easiest. If necessary, you can add a bit a kindling (such as a few dry pine needles or a little paper from your trash bag) to the lower chamber under the tablet to help get things going.

Pot Height

Esbite tablets seem to work most efficiently when the bottom of the pot is positioned only about an inch or so above the top of the burning tablet, so you may need to create a special set of support rod holes to accommodate this height if you regularly burn this fuel.

Alternatively, you can use one of the continuously adjustable pot support methods [described above](#) to position your stove at the optimal height above the tablet.

The Shrinking Tablet

Another issue is that, depending on the coarseness of your burn grate and the precise positioning of the tablet upon it, you may find that the tablet eventually falls through the grate and onto the ground beneath since it will shrink in size as it burns.

If this occurs, you can try placing the tablet on a second small piece of grate material turned sidewise relative to the first (effectively creating a less coarse grate) or on a piece of hardware cloth with a finer mesh. You don't want to use a solid platform made, for example, from aluminum foil or flashing, because the tablet will probably be much harder to light from the bottom. In addition, a solid platform, if cut too large, can also interfere with the supply of oxygen to the tablet.

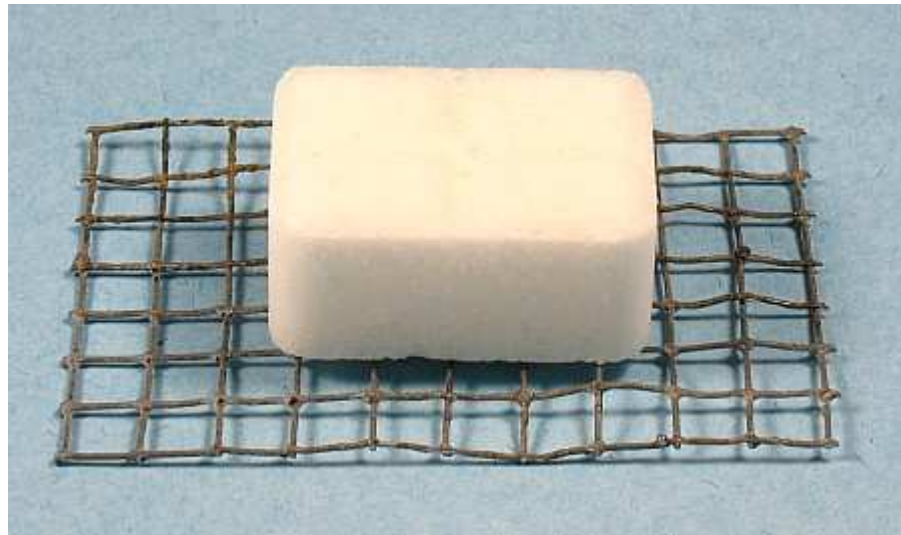

A section of finer mesh hardware cloth placed under an Esbrite tablet will prevent it from dropping through the main grate as it shrinks while burning (+)

Other Burn Platforms

While there are many ways to burn solid fuel tablets, I would specifically not recommend using a Super Cat alcohol stove, or the optional stove holder discussed below, as a tablet burn platform. The tablet will deposit a gummy residue on the stove or the holder and probably also melt a portion of the aluminum wall.

WOOD STOVE MODE

Using wood as a stove fuel has a lot of appeal for some folks, especially if hiking mostly below tree line. Though campfires have generally fallen into high disregard among leave-no-tracers (and are prohibited in many places) the tiny fires built in ultralight wood stoves are a different animal.

It turns out that very little wood is required to boil a couple of cups of water, a task that can often be accomplished within 10 minutes of lighting a fire if using dry fuel. The Fire Bucket is

a very efficient wood stove, primarily because the incoming oxygen flows easily through the large ventilation port, then is drawn upwards, directly through the burning fuel.



The small amount of wood fuel shown above is usually sufficient to boil 2 to 4 cups of water (+)

On the downside, the Fire Bucket, like most wood burners, has a couple of notable disadvantages: (1) it can deposit soot on the inside of the stove as well as on cook pots; and (2) it can infuse your hair and clothing with smoke odors if you linger near the fire for too long. Neither is a big deal for most backpackers, however, who often use simple techniques to work around these issues.

For example, it's not very difficult to remove loose soot from pots and stoves simply by wiping with a damp cloth or sponge. While the more persistent pot blackening that often occurs is more difficult to clean, it's also said to help cooking vessels absorb heat energy, so most hikers just leave it in place.

Regarding smoke, the amount that's produced by the Fire Bucket is partly a function of the species and moisture content of the wood used (hard, dry woods usually smoke the least), and partly a function of the phase of the burn.

As wood first starts burning, it tends to produce more smoke, but as the temperature of the fire increases, smoke production generally drops off significantly. In any event, if using the fire primarily to boil water rather than doing the kind of cooking that requires frequent pot tending, it's usually easy to maintain enough distance between you and the stove to minimize your exposure to smoke.



**Smoke is heavier
early in the burn (+)**



**Smoke production generally drops
as the temperature increases (+)**

As a point of clarification, I will also note that the Fire Bucket is not what's known as a wood gas or "inverted down-draft gassifier" stove. That type of stove, which may burn with even greater efficiency, is also more complex (requiring a double-skinned burn chamber) and is generally heavier. On the flip side, these stoves tend to produce less soot and smoke than do non-gassifier types.

If you're seriously interested in using wood as a fuel, you might want to construct a wood gas stove using instructions found on any number of Internet sites (they're fun to build and operate). For occasional use as a backcountry wood stove, however, I think you'll find that the Fire Bucket is an excellent, lightweight alternative.

Fueling and Lighting the Stove

To begin, remove your pot supports (if appropriate, depending on type), then load the burn chamber with pieces of small branches, perhaps pencil-sized in diameter and broken into lengths of 3 to 5 inches, until you have a pile about two inches high.

That modest amount of fuel may only burn for ten or fifteen minutes, but will probably produce enough heat for most cooking chores. If you need more fuel, you can always add wood either by removing the pot and dropping it in through the top, or by feeding it in through the pot handle opening.

Next, insert a charge of tinder into the bottom chamber under the burn platform. A little crumpled paper or a small pile of dry pine needles should be sufficient to get things rolling as long as your wood is dry.

Alternatively, a bit of alcohol fuel dripped over the fuel supply and allowed to pool at the bottom of the bucket should also work. I'll note that I actually prefer this method because it's cleaner and faster. Paper and similar tinder materials tend to produce more smoke while also creating a fair bit of ash that can fly about in a breeze.

And speaking of breezes, I'll further note that wood fires, unlike alcohol stoves or solid fuel tablets, are usually assisted, rather than disrupted, by a little air movement, so you needn't be quite as concerned about sheltering the stove from the wind when burning wood. In other words, you probably won't need to use your [optional wind shade](#).

Anyway, you can now replace your pot supports and light the tinder or the alcohol pool through the ventilation port.

Be advised again (see the [Safety Note](#) above) that if using alcohol fuel to help start a wood fire, its vapors will be circulating inside the Fire Bucket, which means that ignition will likely

[happen with a "whoosh" \(in other words, a potentially startling flare-up\)](#). There should be no problem, however, as long as your face, hands, clothing, and shelter are kept well clear of the stove during this ignition process.

I'd suggest that you wait a couple of minutes after ignition to allow the fire to come up to speed, then place your cook pot on the supports. The use of a lid will accelerate the heating process and will also help keep particulates generated by the fire out of your pot.

One tip I'll mention here is that if the flame begins to falter, it may help to lift the pot from the Fire Bucket for a few moments to help infuse it with oxygen. With more air, the fire should begin to burn hotter, which will in turn stoke the chimney effect by drawing more air through the ventilation port. This effect should persist, at least for a while, after the pot is placed back on the stove.

The video below demonstrates the use of a Fire Bucket in wood burning mode. If you're not able to stream Internet video, or if you'd just like to keep a local copy, you can also [download an MPG version](#) of the video (2 min, 5 sec length, 30mb file size).

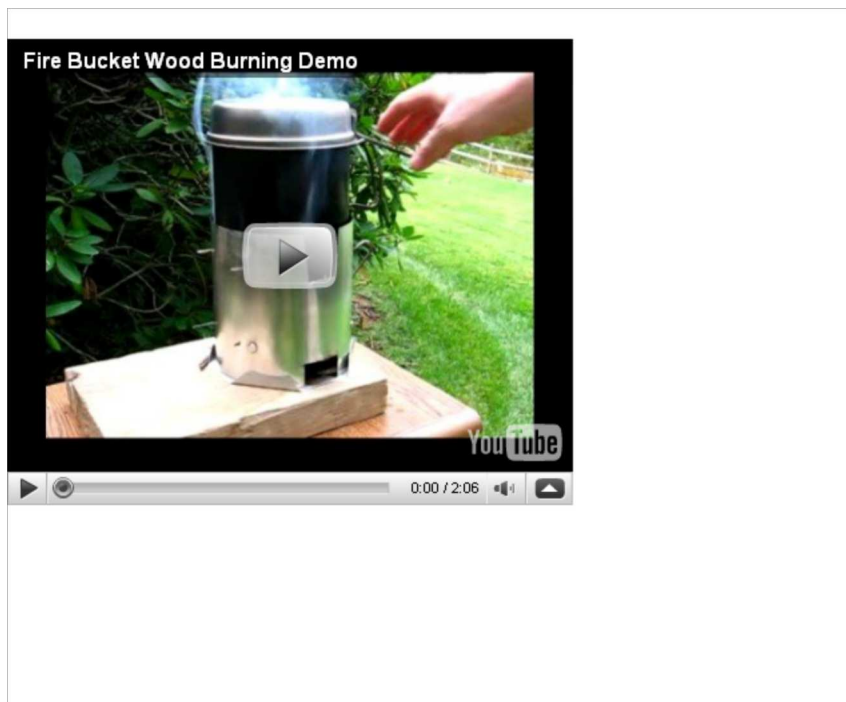

Fuel Strategies

Finally, as you consider fuel strategies for any given trip, I'll note that even if you prefer to use primarily wood, you'll probably also want to have a backup such as alcohol or solid-fuel tablets available for those times when you make camp in the pouring rain, you're bone cold, and the prospect of having to search around for dry wood is really unappealing.

LIGHTERS and MATCHES

There are, of course, many ways to ignite backcountry stoves and most experienced hikers will usually have already settled upon a personal favorite. Nonetheless, I thought it might be useful to weigh in with a few Fire Bucket-specific comments. I'll also note that there's a good bit of useful information available at the [Backpack Gear Test website](#).

Lighters

One of the more popular methods of lighting stoves is with butane lighters such as those

made by Bic, Ronson, Tokai, Calico and others. Aside from being inexpensive, these lighters are also lightweight and durable, but there are at least a couple of issues, especially when used with the Fire Bucket.

The first, of course, is that these lighters are designed primarily for use with tobacco products, so your hand ends up very close to the flame. That's perhaps OK for a cigarette, but not so good for starting a stove where accumulated flammable vapors can sometimes cause brief flare-ups during ignition. This design can also present a burn hazard when the lighter needs to be held horizontally, rather than vertically, in order to start a stove.

A second problem is that most of these lighters don't work very well, or perhaps at all, in cold weather. Most inexpensive lighters are fueled with regular butane (also known as n-butane), which has a boiling point of 31°F (-0.5°C). As soon as the air temperature drops much below freezing, the butane will simply refuse to vaporize and the lighter will cease to function. I've found this to be the case even if the lighter is stored in a warm jacket pocket because the moment the butane gas is exposed to the cold air, it immediately becomes uncooperative.

A few lighters, such as those made by Ronson, are fueled with isobutane, which has the same molecular formula (C₄H₁₀) as n-butane, but a different structural formula (i.e., it's a butane "isomer"). The boiling point of isobutane is 11°F (-11.7°C), which makes its cold weather performance better than n-butane, but even so, vaporization at temperatures below freezing can still be a bit sluggish. And when temperatures drop below isobutane's boiling point, these lighters will likewise cease to work at all.



Widely-available Bic lighter * (+)



Ronson lighters use isobutane for improved cold weather use (+)

* Bic and most other inexpensive butane lighters are probably filled with standard n-butane fuel, but because the ingredients are not listed on the packaging and because related MSDS documents are either not available or difficult to obtain (mostly from Chinese sources), I haven't been able to determine the precise fuel components. Ronson, in contrast, does make MSDS's for its products [readily available](#).

An alternative is a butane candle-style lighter, where the flame port is moved away from the hand via a metal extension tube. This design solves the hand-to-flame proximity problem, but not the cold weather performance issue. And at weights of 2 to 3 ounces, these kinds of lighters are also significantly heavier than the ½ ounce or less of standard models. They are, however, very handy for testing alcohol stoves in home or laboratory settings.



Dollar-store candle lighter (+)



Solo brand candle lighter (+)

Most candle-style lighters use [piezoelectric](#) ignition where a small spark is generated at the end of the extension tube in order to ignite the butane gas. It turns out that even if the lighter's butane gas won't ignite, this spark alone is sufficient to start some kinds of stoves, most notably butane/propane canister models.

Interestingly, I've discovered that the spark alone from some candle-style lighters can also be used to start an alcohol stove like the Super Cat. For this ignition method to work, however, the lighter's spark point must be located near the tip of the extension tube (rather than at some distance up the barrel) and the lighter's tube must usually be dipped into the alcohol pool for ignition to occur. When lighting the Super Cat inside the Fire Bucket, this spark-only method still requires that the hand usually be placed directly above the stove during the starting process (which makes the user susceptible to burns) and thus is not recommended.

If you perform a quick search on the web, you'll find that butane lighters are offered in a huge variety of styles and prices, with some supposedly "hardened" for use in outdoor survival situations. All told, however, I'd suggest passing on such products and sticking with the venerable wooden match that works in a much broader range of conditions.

Wooden Matches

While we tend to think of the common wooden friction match as pretty low tech these days, it was considered a marvel of engineering when it was [first introduced in 1827](#). For lighting most backcountry stoves, however, it remains a great technology.

Today's wooden matches are generally reliable and safe, allowing the user to position his or her hand some distance from the flame. They also perform well under even extremely cold conditions, though dampness, of course, can sometimes cause problems. The heads of these matches will likewise usually burn long enough to start most stoves, even if the wooden splints don't catch fire (as might be the case when it's very windy).

There are specialty matches, of course, that are designed for use in extreme environments and that are usually coated with wax or similar substances to help make them waterproof. For everyday use with the Fire Bucket, however, these types of matches are probably overkill and unnecessarily expensively. They're also harder to light, and because more force is generally required while striking, I find that they also break fairly easily (at least that's the case with the Coghlan's waterproof matches pictured below).



Storm-proof matches from REI (+)



Coghlan's waterproof matches (+)

Instead, I normally use standard wooden matches in both the strike-anywhere and safety match varieties ("safety matches" require a compatible striking surface, normally located on the side of the box). Wooden matches are typically available in two sizes: (1) the larger "kitchen match" size which is 2.4 inches long and has a beefier splint and (2) the smaller "penny match" size, which is 1.7 inches long and has a thinner wooden splint.



I like both the strike-anywhere and the safety versions of wooden matches in both the kitchen and penny sizes (+)

Because these matches are not waterproof, it's important to store them in watertight zipper-bags or hard-sided containers. If you're a "belt-and-suspenders" kind of backpacker (such as myself), you may also wish to carry a separate supply of storm-proof matches for starting emergency campfires under particularly challenging conditions.

I will also note that a final advantage of wooden matches is that they can be easily used with Jim's simple wine cork "match extender" accessory that's discussed in the ["Accessories"](#) section below.



Using a wine cork match extender (+)

Accessories

While one of the Fire Bucket's great attractions, at least for me, is the simplicity of design, there are a few optional accessories that you might want to consider.

THE WIND SHADE

The wind shade is a simple baffle that can be inserted into the ventilation port of the Fire Bucket to reduce air turbulence inside the screen under particularly windy conditions.

The one shown below, which is made from 9 mil thick aluminum flashing, is 5 inches long and weighs $\frac{1}{4}$ ounce.

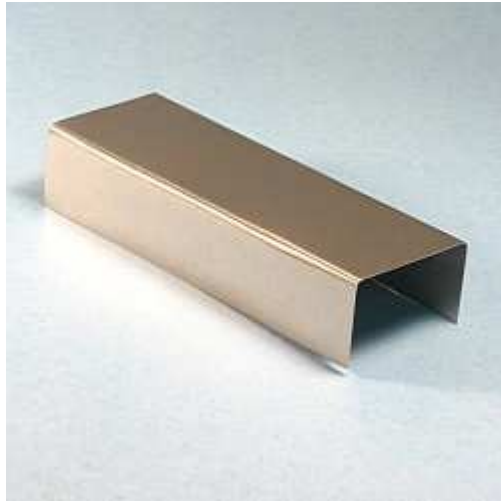

Wind shade (weight = ¼ oz) (+)



Positioned in ventilation port (+)

A couple of construction tips:

1. Because you'll want the wind shade to slide into the ventilation port with a reasonably tight fit, it's important to get the bends in the right positions. To do so, I'd suggest that you bend one edge first, then measure (or re-measure) before finalizing the location of the second bend line. If you end up with a wind shade that's slightly too wide, you can enlarge the port a bit by cutting or filing. If it's too narrow, however, you'll need to start over. If my experience is any indication, it may take two or three tries to get it right.
2. The use of a bench vise or sturdy straight edge held firmly against the metal at the appropriate position can help produce straight lines when bending the edges. It may also help with some materials (such as aluminum flashing) to lightly score the metal with an awl along the outside of the bend line. Just don't make the scores too deep, however, or the bends will be weakened and could break.

When the bends are complete, you can then trim the sidewalls of the wind shade if necessary to achieve an optimal fit. Finally, you'll want to snip off any sharp corners at the bottom edges.

In the field, you'll probably find that the wind shade is most valuable with alcohol and solid-fuel based burns. That's because wood fires can actually often benefit from a little air movement inside the screen which tends to help oxygenate the flame.

If you normally start your alcohol stove or solid-fuel tablet through ventilation port, you'll probably want to first set the wind shade aside, light the fuel, and then carefully slip the wind shade into the port after startup.

You may have to experiment to determine the best positioning, but inserting an inch or so of the shade into the Fire Bucket, and leaving about 4 inches outside works well for me. You may also find that placing a stone or two on the top of the wind shade will assist in keeping it in place. Likewise, piling a little dirt around its junction with the Fire Bucket can help to create an air-resistant seal.

THE SCREEN HEIGHT EXTENDER

Another accessory that might be helpful in windy conditions is a screen height extender. Whether or not this option will be of value to you depends largely upon how much your cook pot extends above the top edge of the screen when it's positioned normally.

With its lid is in place, my Snow Peak Trek 1400 pot rises about 3 inches above the screen

when resting atop a Super Cat alcohol stove. While this arrangement normally provides adequate protection for the flame, robust winds can sometimes strike the pot from the sides and deflect air downwards, creating flame turbulence. By extending the screen height 3½ inches or so, this turbulence can largely be eliminated.

The screen height extenders shown below are both cut from aluminum and attached to the Fire Bucket using ½" long machine screws and wing nuts. I was able to use existing holes for mounting, so no additional holes needed to be drilled. Likewise, I was also able to use the existing screw and nut at the top rear, so I only needed to add two more screws for attachment near the pot handle opening.

The extender on the left below is made from the same aluminum flashing as the screen and weighs 1.0 ounce. With another 0.2 ounces for the additional two screws and nuts, the total weight is 1.2 ounces.

Because the extender normally won't need to support your pot, you can save a bit of weight by using lighter aluminum. The extender on the right below, for example, is constructed from a disposable Hefty aluminum cookie sheet. With screws and nuts, it comes in at 0.7 ounces total, which saves about ½ ounce over the first model.



**Screen height extender
made from flashing
1.2 oz w/ attachment screws (+)**



**Screen height extender
made from a cookie sheet
0.7 oz w/ attachment screws (+)**

The extender can be easily constructed by measuring and cutting the aluminum to the desired dimensions, then drilling or punching screw holes where necessary. If fitting the extender to a permanently assembled Fire Bucket, you may need to add an extra hole or two in the screen wall if none already exist.

As a final note, I'd recommend that if you find that you're using your height extender most of the time in the field, you might want to consider just build a taller Fire Bucket using wider screen materials. Not only will it be more convenient to use, but you'll also save a little weight when compared with the extender approach.

THE ALCOHOL STOVE HOLDER

When using almost any alcohol stove with a windscreen, it's usually desirable to keep the stove positioned at or near the middle of the screen so that its flames heat the cook pot evenly. Centering the flame also helps assure that no one section of the screen becomes overheated, potentially causing a meltdown (at least with aluminum models).

One not-so-great method of centering the stove in the Fire Bucket is to press down gently

in the middle of the burn platform with a blunt object an inch or two wide, bending the platform slightly so the that stove will tend to gravitate towards this indentation.

A much better solution, however, is to build a holder for the stove which can be fitted with three small machine screws secured with nuts that can protrude through the burn grate to keep the stove from shifting about, while still allowing it to be easily inserted and extracted. This separate holder eliminates the need to make holes in the bottom of the stove itself which could otherwise cause fuel leakage.



**Holder for a
Super Cat alcohol stove (+)**
(weight = 0.2 oz)



**Similar holder for a
Pepsi can alcohol stove (+)**
(weight = 0.3 oz)



**Top view shows
screw positions (+)**



**Bottom view shows
screw "legs" (+)**

Such holders can be easily constructed for Super Cat stoves as well as for most Pepsi or Red Bull models using a technique that was first described in connection with the original Super Cat stand. The complete build instructions [can be found here](#).

Briefly, this holder, which is called a "docking socket" in that article, is constructed from a single aluminum can of the same type used for the stove. This second can is simply cut down with scissors to a height of about 5/8" above its base and outfitted with a single slit in the wall as shown above.

Once the holder is cut, three equally-spaced holes can be drilled or punched in the bottom

through which ½" long, #4 or #6 machine screws can be installed. The stove can be then be plugged into or removed from the holder with a twisting motion. The average weight of these holders is about ¼ ounce.

Not only will a holder-equipped alcohol stove stay where you want it once it's lowered onto the burn grate, but it will also be less prone to tipping over when in use. And if you really want to lock it down, you can anchor it to the burn grate simply by adding a flat washer and nut (standard or wing) to each machine screw on the underside of the mesh, tightening the nuts in place against the grate.



Super Cat alcohol stove docked with holder (+)

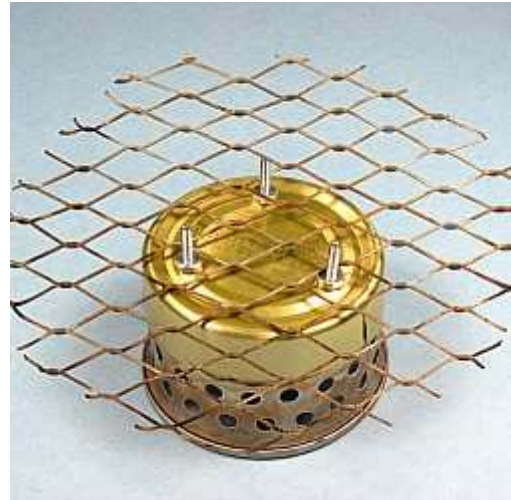

Holder legs protrude through the burn grate (+)

SMOTHER PLATFORM

Because of the Fire Bucket's open burn platform, the use of a device like the snuffer cup ([discussed in the Super Cat article](#)) to smother the flames won't work without modifying the design. If stopping the stove by depriving it of oxygen is important to you, however, one solution is to add a base around the stove holder described above that's wide enough to serve as a "smother platform" for the snuffer cup.

To create the base, just excise the bottom from a 5½ or 6 ounce pet food can of the same type used for the snuffer cup itself (to assure an optimal fit), or cut an appropriately-sized disk from aluminum flashing. I will note that because of the ridges stamped into its surface, the can bottom may maintain its shape better when heated than will a flat aluminum disk.

Next, drill or punch 3 small holes in positions that line up those in the the holder itself, then bolt the new platform into place beneath the holder as shown below.



Smother platform added to the bottom of a stove holder (+)



"Snuffer cup" covers the stove to extinguish the flame (+)

When the smother idea first occurred to me, I was concerned that the platform might block the flow of oxygen to the stove, but after a fair bit of testing, it became apparent that airflow was not a problem at all.

In fact, in a surprising development, it turned out that the platform actually caused the stove to burn faster and hotter, reducing boil times by 10 or 15%. I can only surmise that the slight added mass of the platform must somehow help the boiling alcohol pool to maintain its heat energy more effectively.

I will note, however, that it can be tricky to lower a standard snuffer cup that includes a top-mounted knob into place while the stove's flames are raging inside the screen without burning oneself. To solve the problem, I'd recommend a slight modification.

When using the cup with the Fire Bucket, simply remove the knob and pass an aluminum tent stake up through the center hole to create a handle. I've tried both hook and nail-type stakes, and both work well. When you want to extinguish the flame, lower the cup over the stove (holding the end of the stake) until the cup mates with the smother platform.



**Snuffer cup with hook-style titanium tent stake (+)
(hook end goes inside the cup)**



Lower the cup at an angle to direct flames away from your hand (+)

You'll find that it helps to lean the cup towards the back of the Fire Bucket as it descends (see photo above) to direct the flames away from your hand. You can then bring the stake to vertical just before the cup comes to rest on the smother platform. I've used this technique many times and it works beautifully, extinguishing the flame almost instantly.

It might also be handy to have a separate, dedicated Fire Bucket version of the snuffer cup that is knob-less and whose center hole's diameter is optimized for the size tent stake that you'll use most often. Note that if you also use your Fire Bucket-specific snuffer cup to assist in fuel recovery [as described](#) in the Super Cat article, you'll need to keep the center hole plugged (perhaps momentarily with your finger), in order to keep the dumped fuel from leaking out.

A BUCKET FLOOR

If your Fire Bucket has an open bottom, you can place a few layers of aluminum foil beneath the stove to enjoy some of the benefits of a "floor" as [discussed above](#).

If you'd like something a bit more durable, however, you can construct a simple removable floor from aluminum flashing, a piece of sheet metal or a section of oven liner.

Start by first cutting a square a little larger than the circular bottom of the stove, then bend the corners of the square upward at a 90° angle to create retainers that will keep the stove centered on the bottom. If desired, you can also trim these retainers so that they're about ½ inch high (you'll also want to snip off all sharp corners).

The bottom shown below is cut from 9 mil aluminum flashing and weighs ½ ounce.



Floor made from aluminum flashing (weight = ½ oz) (+)



Floor in place under Fire Bucket (+)

If your Fire Bucket is built with a removable burn platform, this type of bottom can also serve as a convenient carrier for that platform when it's not in use (I store the two nested together in a Ziploc bag). The oversize shape and bent corners of the bottom will help keep any sharp edges of the burn platform from puncturing neighboring items in your pack while being transported.

A BARBEQUE GRILL

When using your Fire Bucket as a wood burner, you can actually barbeque meat, fish, or vegetables with the addition of a small circular grill that can be positioned either on your pot supports or rested on the top edge of the screen. You'll need to be careful in your

selection of grill metals, however, since you won't want to ingest the toxins that are present in some metal coatings (like zinc-based galvanizing compounds, for example).

A clever choice is a [fan guard](#) that's designed for installation on a computer chassis to keep fingers and other objects from contacting the power supply fan. Some specialty companies that cater to enthusiasts who modify or custom-build computers sell a variety of metal fan guards that are constructed from materials like stainless or chrome-plated steel that are normally considered to be safe for grilling.

One example is shown below. With [this model](#), you can either remove the mounting flanges with wire cutters or not, depending on your Fire Bucket configuration. The grill that I use is of this design, is 4½ inches in diameter, and weighs 1½ ounces.



**Jim's grill: a computer fan guard
w/ mounting brackets removed (+)**



**Grill in place
on support rods (+)**

Another option for the grill is wire mesh constructed from a food-safe metal. I found one online vendor, [TWP, Inc.](#), sells many of its products (including stainless steel mesh in various sizes) in sample-sized 6" x 6" swatches.

By the way, I should note before leaving this topic that barbequing in bear country is probably not a great idea, since cooking odors can carry a long way, often serving to ring the dinner bell for local bruins. These odors can also penetrate deeply into clothing and shelter fabrics and make mandatory the fastidious cleanup of your stove as well as its overnight storage with your food bags.

JIM'S MATCH EXTENDER

If you'd like to increase the safety distance between your hand and the Fire Bucket when lighting a fire with a wooden match, you can make a simple extender from an ordinary wine cork (either a natural or a plastic cork works fine). Such an extender is particularly useful when it's necessary to reach over the top edge of the Fire Bucket in order to light a stove or a wood/tablet fire. In particular, when using an alcohol stove, vapors can often accumulate inside the walls of a windscreen prior to ignition, so it's best to keep your hand outside the screen (as noted above) in case there's a flare-up.

You can construct a match extender by boring a small hole into each end of the cork using an awl or a nail. These holes, which need be only about ½ inch deep, can then be used to hold a wooden match at one end, and some sort of handle at the other. Most corks weigh less than ¼ ounce, and if you're a gram counter, you can even cut the cork in half to further reduce the weight.

The handle I generally prefer is a thin titanium tent stake (as shown below), though a slim wooden branch, a Fire Bucket pot support, another wooden match (preferably spent), [Jim's bagel toaster](#), or even a short length of coat hanger wire all work well.

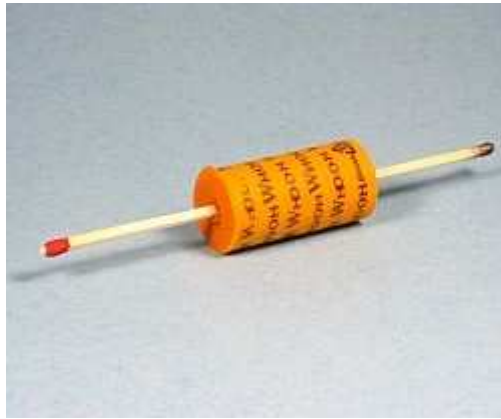

Using a spent match as a short handle (+)



A thin titanium tent stake makes a longer handle (+)



A small hole is bored into each end of the cork (+)



Positioning the match extender (+)

To use the extender, first insert the handle in one end of the cork, and an unburned match in the other. Then strike the match with the extender in place and move it towards the desired ignition point while holding the handle end.

Fire Bucket Tips and Tricks

- If operating your Fire Bucket in particularly windy conditions, you may want to use the wind shade described above. If you don't have one handy, however, it might help to create one or more baffles inside the bottom chamber in order to reduce air turbulence inside the stove.

One small rock about an inch high, placed a ½ inch or so inside the ventilation opening, and perhaps joined by two or three others deeper inside the chamber should help slow down reflections in the incoming air stream without significantly restricting flow volume.

You might also try building a small, roofed "porch" in front of the ventilation opening using small rocks for the sides, and a piece of bark as the top, all covered with dirt to reduce air leaks. When positioning any man-made material near the vent port, remember that the walls of the Fire Bucket can become hot enough to melt nylons and other synthetics.

In brisk winds, it may also help to seal the bottom edges of the Fire Bucket against the ground by piling up a little dirt around the edges of the walls and/or the wind shade, if present.

- If you anticipate really windy conditions, you could either cook (with great care) in the vestibule of your tent, or alternatively, you might want to supplement the Fire Bucket with a [KiteScreen](#) fabric-based barrier. In either case, cooking would need to be limited to alcohol or solid-fuel tablets since wood fires would be too dangerous in either of these two situations.
- If you'd like to slow down the burn rate of your stove, perhaps for simmering purposes, you can partially block the ventilation port. This task might be accomplished by folding up a bottom layer of aluminum foil partially over the opening, or maybe by partly covering the port with a pile of dirt pushed in front of it.
- If you'd like to stake your Fire Bucket to the ground to help prevent movement in the wind (which could result in a possible upending), one way is to drill or punch two small holes near the bottom edge of the screen, preferably on the same sides as the pot support holes to minimize air entry. You can then insert a thin titanium stake through each hole at an angle and into the ground to secure the screen.

Another method that doesn't require drilling holes is to simply plant two hook-style stakes into the ground inside the screen, right through the burn platform. You'll want to push the stakes until the hooks engage with the burn grate, which will, in turn secure the entire unit, even on removable support models.

- If you have a model that uses either removable burn grate or pot supports, and find that the straight ends of the support rods falls back through their holes too easily, you can clamp the straight end of each using a small office binder clip to keep them in place. These binder clips have two notches on each side of the clamp than can lock into the shafts of most thin support rods when installed as shown below.



Small binder clips
secure support rods (+)

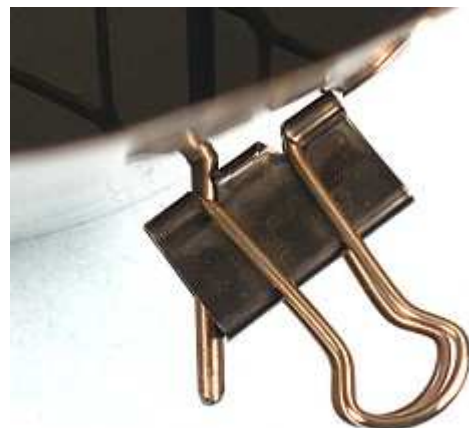

Close-up shows how notch in
clip locks into rod (+)

- While constructing your Fire Bucket, if you punch or drill holes that you later consider to be mistakes, you can plug those holes using flattened pop rivets, [JB-Weld](#) heat-resistant epoxy, or small screws.
- If you'd like to remove the hole or cut marks you created on the walls of the Fire Bucket with your permanent felt-tipped pen ("Sharpies" work well for the purpose, by the way) for cosmetic reasons, the task can usually be accomplished by wiping the marks with a cloth or paper towel that's been wet with a bit of a household solvent like Goo Gone or Goof-Off.

Resources and Feedback

FURTHER READING

By far the most thorough analysis I've seen to date regarding the effects that wind has on stove performance was prepared by Will Rietveld at [Backpackinglight.com](#) in 2006.

[Part I](#) of his review discusses primarily theory, while [Part II](#) deals with practical applications for the field. To read the full text of these articles, you'll need a BPL.com online subscription, which is currently \$24.99 per year (and well worth the cost, in my opinion); otherwise, only article abstracts will be available. By the way, I have no affiliation with BPL.com other than as a standard subscriber.

USER FEEDBACK

I consider the Fire Bucket to be a work in progress. By virtue of the the unrestricted release of this article, I am placing the Fire Bucket's design concepts into the public domain for users to modify or improve upon as they wish.

I'm sure, in fact, that there are aspects of the Fire Bucket that haven't even occurred to me, but that will be obvious to others. So if you take an interest in the design, please report back through the feedback forum (link below) on your experiences and recommendations. This "open source collaboration" (to borrow a phrase from the software industry) will strengthen the design for all of us.

[You can submit or read comments about this article here.](#)

CONTACT ME

If you'd like to contact me directly, [please do so here.](#)

[Top](#)
[Home](#)

Copyright © 2008-2009 James E. Wood. All Rights Reserved.