

CHAPTER 6
CALIBER .32 CARTRIDGES

CARTRIDGE, CALIBER .32, BALL

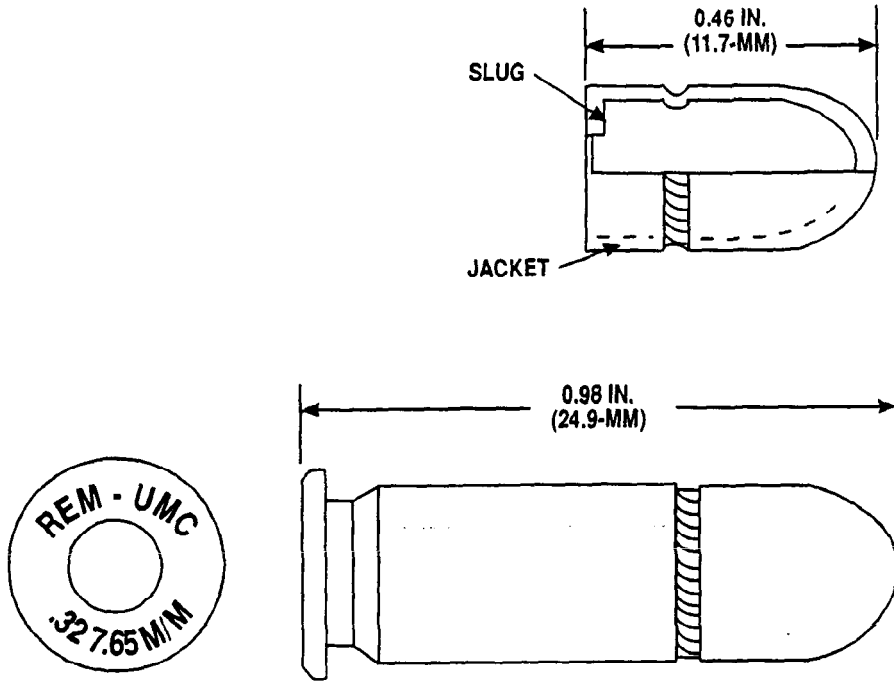

U
AR 5913

Type Classification:

Commercial.

Use:

Caliber .32 weapons. The cartridge is used in caliber .32 automatic pistols for defensive use against personnel.

Description:

BALL Cartridge.

Tabulated Data:

DODAC..... 1305-A350
 UNO serial number 0012
 UNO proper shipping name..... Cartridges for weapons, inert projectile
 Weight 115 gr
 Length..... 0.98 in. (24.9 mm)
 Tracer..... NA
 Primer..... Percussion
 Fuze..... NA
 Explosive:
 Type NA

Weight..... NA
 Incendiary:
 Type NA
 Weight..... NA
 Propellant:
 Type Smokeless powder
 Weight..... MBR

Performance:

Chamber pressure 15,000 psi
 Velocity 900 fps, 15 ft from muzzle

Shipping and Storage Data:

Quantity-distance class/
 SCG 1.4S
 Storage code Class V
 DOT shipping class C
 DOT designation SMALL ARMS AMMUNITION
 Drawing number 10524631

References:

SB 700-20
 TM 9-1005-206-14P/3
 TM 9-1300-206

CHAPTER 7
CALIBER .38 CARTRIDGES

CARTRIDGE, CALIBER .38, BALL

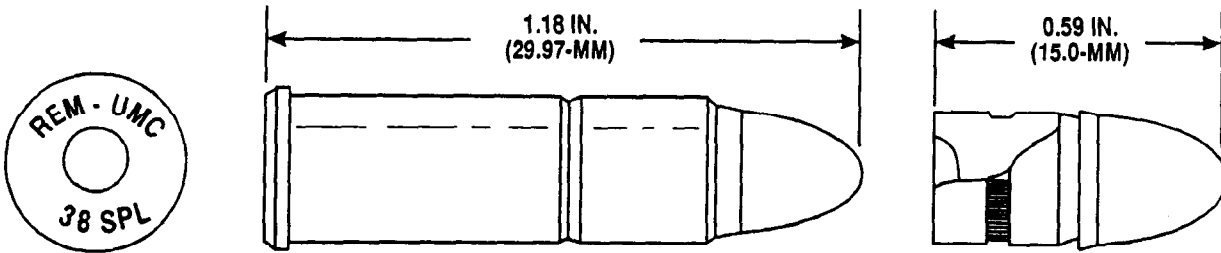

U
AR 5914

Type Classification:

OBS - MSR 11756003.

Use:

Caliber .38 weapons. The cartridge is for CONUS-guard or security use in caliber .38 weapons.

Description:

BALL Cartridge. The cartridge has an unjacketed lead bullet.

Tabulated Data:

DODAC----- 1305-A408
 UNO serial number ----- 0012
 UNO proper shipping
 name----- Cartridges for
 weapons, inert pro-
 jectile
 Weight ----- 196 gr
 Length----- 1.18 in. (29.97 mm)
 Tracer----- NA
 Primer----- Percussion
 Fuze ----- NA
 Explosive:
 Type ----- NA

Weight----- NA
 Incendiary:
 Type ----- NA
 Weight----- NA
 Propellant:
 Type ----- Smokeless powder
 Weight----- MBR

Performance:

Chamber pressure ----- 13,000 psi
 Velocity----- 725 fps, 15 ft from
 muzzle

Shipping and Storage Data:

Quantity-distance class/
 SCG ----- 1.4S
 Storage code ----- Class V
 DOT shipping class ----- C
 DOT designation ----- SMALL ARMS
 AMMUNITION
 Drawing number ----- 10524005

References:

SB 700-20
 TM 9-1005-206-14&P-1
 TM 9-1005-206-14P/3
 TM 9-1300-206

CARTRIDGE, CALIBER .38, BALL, SPECIAL, M41

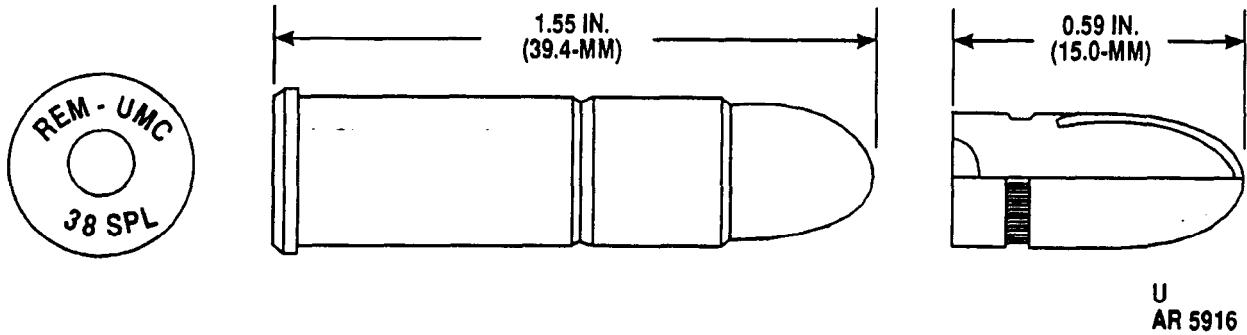

Type Classification:

OBS - MSR 08836015.

Use:

Revolver. The cartridge is intended for use in personal defense hand guns.

Description:

BALL Cartridge. The cartridge has a jacketed bullet.

Tabulated Data:

DODAC.....	1305-A400
UNO serial number	0012
UNO proper shipping name	Cartridges for weapons, inert projectile
Weight	203 gr
Length.....	1.55 in. (39.4 mm)
Tracer.....	NA
Primer	Percussion
Fuze	NA
Explosive:	
Type	NA
Weight.....	NA

Incendiary:

Type NA
 Weight..... NA

Propellant:

Type SR 7325
 Weight..... 4.8 gr

Performance:

Chamber pressure 16,000 psi
 Velocity..... 950 fps, 15 ft from muzzle

Shipping and Storage Data:

Quantity-distance class/SCG	1.4S
Storage code	Class V
DOT shipping class	C
DOT designation	SMALL ARMS AMMUNITION
Drawing number	7553580

References:

- SB 700-20
- TM 9-1005-206-14&P-1
- TM 9-1005-206-14P/3
- TM 9-1300-206

CARTRIDGE, CALIBER .38, WAD CUTTER

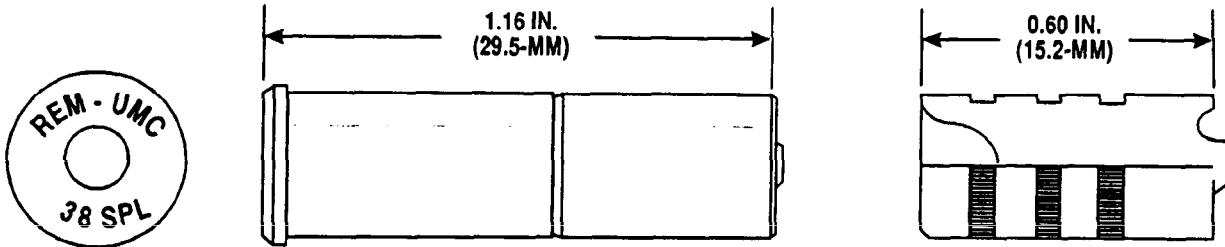

U
AR 5915

Type Classification:

Commercial.

Use:

Revolver, Special, S & W, K-38. The cartridge is used only in pistol competition firing and marksmanship training.

Description:

WAD CUTTER Cartridge.

Function:

The bullet is designed with a concave forward end to act as a paper punch cutting a clean hole in targets.

Tabulated Data:

DODAC----- 1305-A404
 UNO serial number ----- 0012
 UNO proper shipping
 name----- Cartridges for
 weapons, inert pro-
 jectile
 Weight ----- 220 gr
 Length----- 1.16 in. (29.5 mm)
 Tracer----- NA
 Primer----- Percussion
 Fuze ----- NA

Explosive:

Type ----- NA
 Weight----- NA

Incendiary:

Type ----- NA
 Weight----- NA

Propellant:

Type ----- Smokeless powder
 Weight----- MBR

Performance:

Chamber pressure ----- 16,000 psi
 Velocity----- 800 fps, 15 ft from
 muzzle

Shipping and Storage Data:

Quantity-distance class/
 SCG ----- 1.4S
 Storage code ----- Class V
 DOT shipping class ----- C
 DOT designation ----- SMALL ARMS
 AMMUNITION
 Drawing number ----- 10521459

References:

SB 700-20
 TM 9-1005-206-14&P-1
 TM 9-1005-206-14P/3
 TM 9-1300-206

CHAPTER 8
CALIBER .45 CARTRIDGES

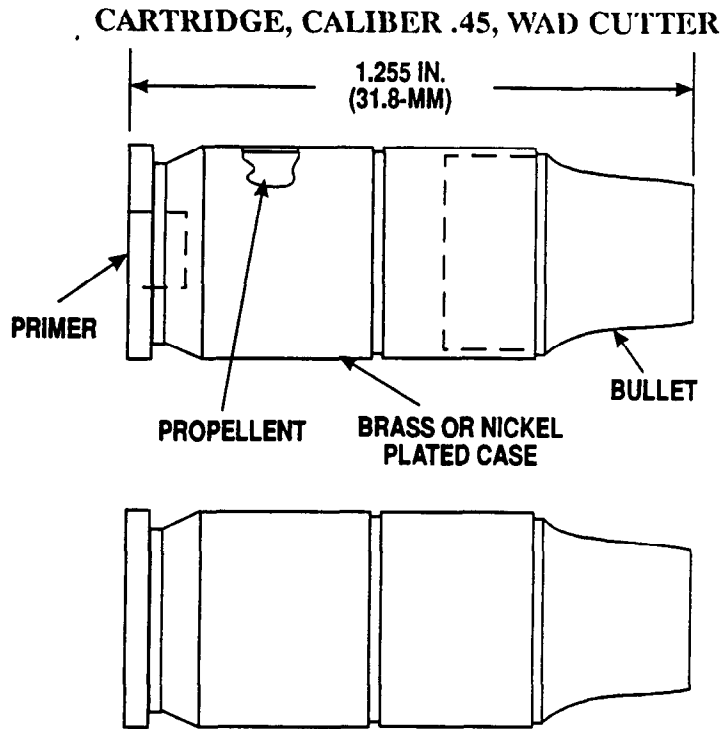

**U
AR 5924**

Type Classification:

OBS - MSR 08836015.

Use:

Pistol, Caliber .45, M1911A1; and Pistol, Caliber .45, National Match.

Description:

WAD CUTTER Cartridge. The cartridge is identified by the bullet shape which has the general appearance of a truncated cone.

Function:

The ogive of the bullet has a sharp shoulder that acts as a hole punch to cut a clean hole in the target.

Tabulated Data:

DODAC----- 1305-A482
 UNO serial number ----- 0012

UNO proper shipping name-----

Cartridges for weapons, inert projectile

Weight ----- 330 gr
 Length----- 1.255 in. (31.8 mm)
 Tracer----- NA
 Primer----- Percussion
 Fuze ----- NA
 Explosive:
 Type ----- NA
 Weight----- NA
 Incendiary:
 Type ----- NA
 Weight----- NA
 Propellant:
 Type ----- Smokeless powder
 Weight----- MBR

Performance:

Chamber pressure ----- 18,000 psi
 Velocity----- 765 fps, 15 ft from muzzle

Shipping and Storage Data:

Quantity-distance class/
 SCG ----- 1.4S
 Storage code ----- Class V

CARTRIDGE, CALIBER .45, BALL, HIGH PRESSURE TEST, M1

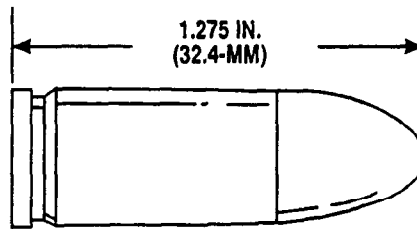
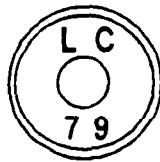
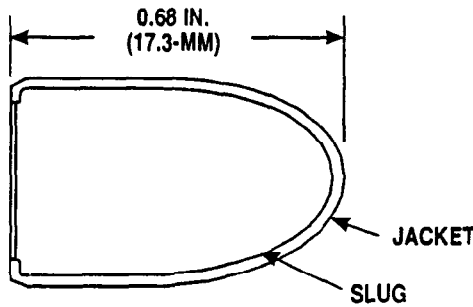

U
AR 5921

Type Classification:

STD - OTCM 36841.

Use:

Test of all caliber .45 weapons. The cartridge is for proof testing caliber .45 pistols and submachine guns during manufacture, test, or repair.

Description:

BALL Cartridge. The cartridge is identified by a stannic-stained (silvered) cartridge case.

Tabulated Data:

DODAC----- 1305-A480
 UNO serial number ----- 0012
 UNO proper shipping name----- Cartridges for weapons, inert projectile
 Weight ----- 332 gr
 Length----- 1.275 in. (32.4 mm)
 Tracer----- NA
 Primer----- Percussion
 Fuze----- NA

Explosive:

Type ----- NA
 Weight----- NA

Incendiary:

Type ----- NA
 Weight----- NA

Propellant:

Type ----- SR 7970
 Weight----- 7 gr

Performance:

Chamber pressure ----- 22,000 psi
 Velocity----- NA

Shipping and Storage Data:

Quantity-distance class/
 SCG ----- 1.4S
 Storage code ----- Class V
 DOT shipping class ----- C
 DOT designation ----- SMALL ARMS AMMUNITION
 Drawing number ----- C6000502

References:

SB 700-20
 TM 9-1005-211-12
 TM 9-1005-229-12
 TM 9-1300-206

CARTRIDGE, CALIBER .45, BLANK, M9

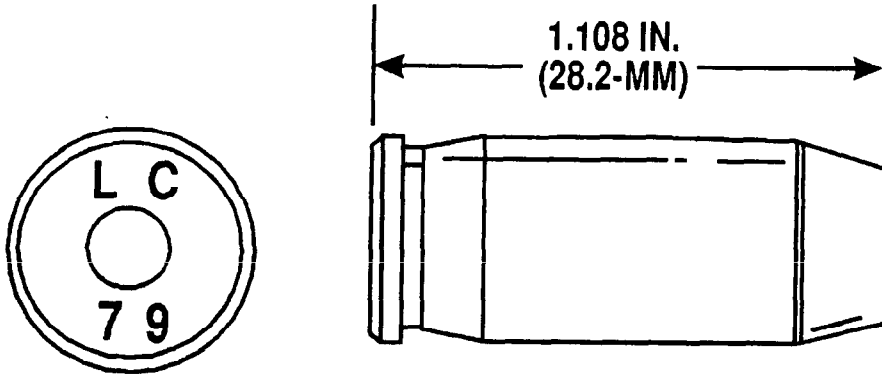

**U
AR 5918**

Type Classification:

STD - AMCTC 505.

Use:

Pistol, Automatic, Caliber .45, M1911A1. The cartridge is used for simulated firing in training manuevers and for saluting purposes.

Description:

BLANK Cartridge. The cartridge is identified by the absence of a bullet and the tapered mouth of the cartridge case.

Tabulated Data:

DODAC----- 1305-A476
 UNO serial number ----- 0014
 UNO proper shipping
 name----- Cartridges for
 weapons, blank
 Weight ----- 104 gr
 Length----- 1.108 in. (28.2 mm)
 Tracer----- NA
 Primer----- Percussion
 Fuze ----- NA

Explosive:

Type ----- NA
 Weight----- NA

Incendiary:

Type ----- NA
 Weight----- NA

Propellant:

Type ----- SR 4990
 Weight----- 10 gr

Performance:

Chamber pressure ----- NA
 Velocity ----- NA

Shipping and Storage Data:

Quantity-distance class/
 SCG ----- 1.4S
 Storage code ----- Class V
 DOT shipping class ----- C
 DOT designation ----- SMALL ARMS
 AMMUNITION
 Drawing number ----- 10523805

References:

SB 700-20
 TM 9-1005-211-12
 TM 9-1300-206

CARTRIDGE, CALIBER .45, TRACER, M26

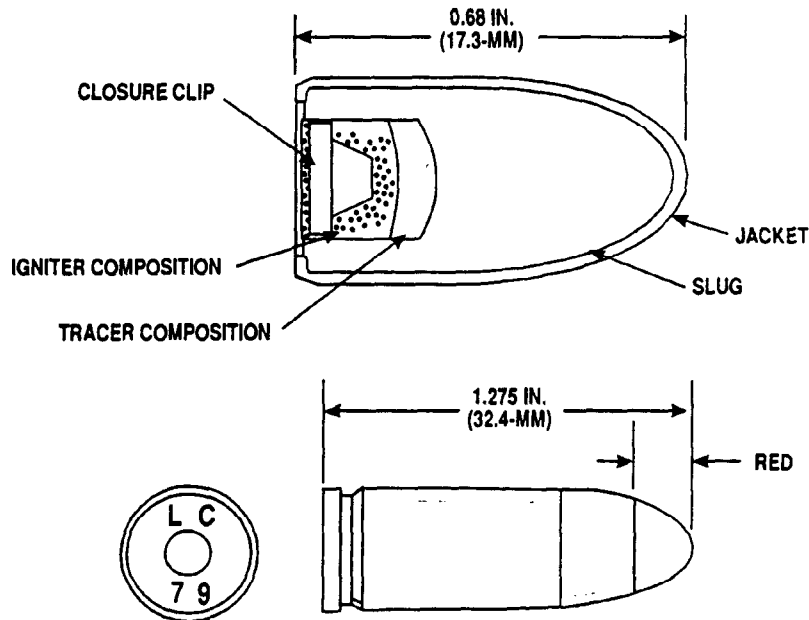

U
AR 5919

Type Classification:

CON - MSR 11756003.

Use:

Submachine Gun, Caliber .45, M3A1; and Pistol, Caliber .45, M1911A1. The tracer is intended to permit observation of the bullet's in-flight path or trajectory to the point of impact.

Description:

TRACER Cartridge. The cartridge is identified by a red bullet tip.

Tabulated Data:

DODAC..... 1305-A479
 UNO serial number 0012
 UNO proper shipping name..... Cartridges for weapons, inert projectile
 Weight 331 gr
 Length..... 1.275 in. (32.4 mm)
 Tracer..... R256
 Primer..... Percussion
 Fuze NA

Explosive:

Type NA
 Weight NA

Incendiary:

Type NA
 Weight NA

Propellant:

Type SR 7970
 Weight 6 gr

Performance:

Chamber pressure 19,000 psi
 Velocity 885 fps, 25.5 ft from muzzle

Shipping and Storage Data:

Quantity-distance class/
 SCG 1.4S
 Storage code Class V
 DOT shipping class C
 DOT designation SMALL ARMS AMMUNITION
 Drawing number 10534359

References:

SB 700-20
 TM 9-1005-211-12
 TM 9-1005-229-12
 TM 9-1300-206

CARTRIDGE, CALIBER .45, LINE THROWING, M32

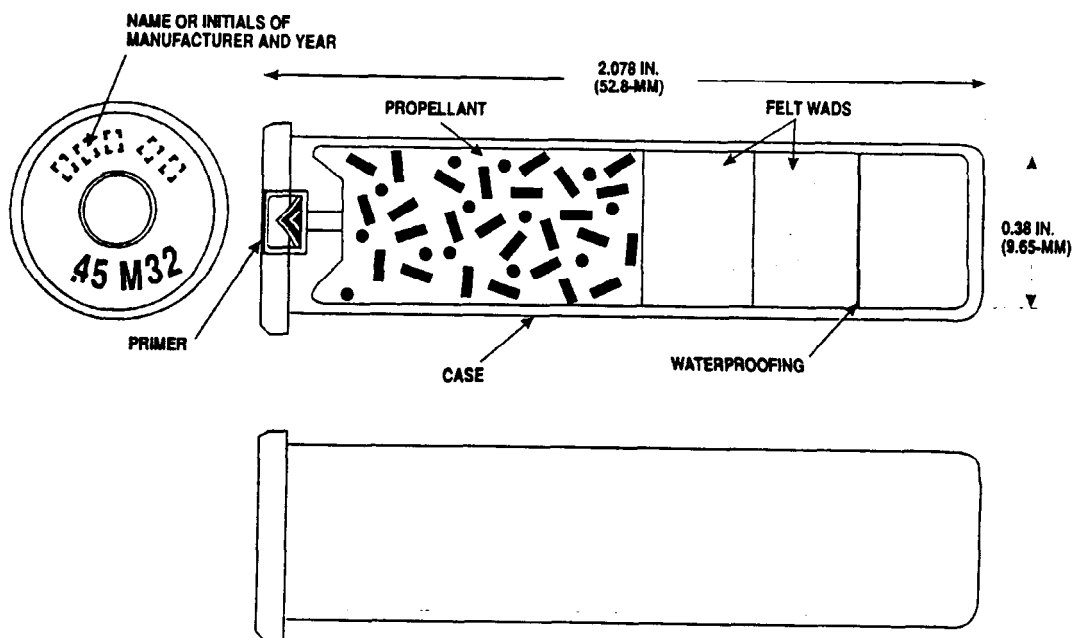

U
AR 5920

Type Classification:

STD A - OTCM 36841.

Use:

Line Throwing Gun, Caliber .45/.70.

Description:

LINE THROWING Cartridge. The cartridge is composed of a brass case, primer, commercial smokeless powder, and two felt wads coated on both sides with gummed paper. The wads are sealed with red lacquer. The cartridge case mouth is crimped to prevent entry of the line throwing rod.

Function:

The line throwing rod is placed in the weapon barrel. Cartridge initiation provides pressure to force the rod out of the barrel and propel the line to the target.

Tabulated Data:

DODAC----- 1305-A477
 UNO serial number ----- 0014

UNO proper shipping

name-----	Cartridges for weapons, blank
Weight-----	192 gr
Length-----	2.078 in. (52.8 mm)
Tracer-----	NA
Primer-----	Percussion
Fuze-----	NA
Explosive:	
Type-----	NA
Weight-----	NA
Incendiary:	
Type-----	NA
Weight-----	NA
Propellant:	
Type-----	Smokeless powder
Weight-----	MBR

Performance:

Chamber pressure ----- 20,000 psi
 Velocity----- NA

Shipping and Storage Data:

Quantity-distance class/
 SCG ----- 1.4S
 Storage code ----- Class V

CARTRIDGE, CALIBER .45, BALL, M1911

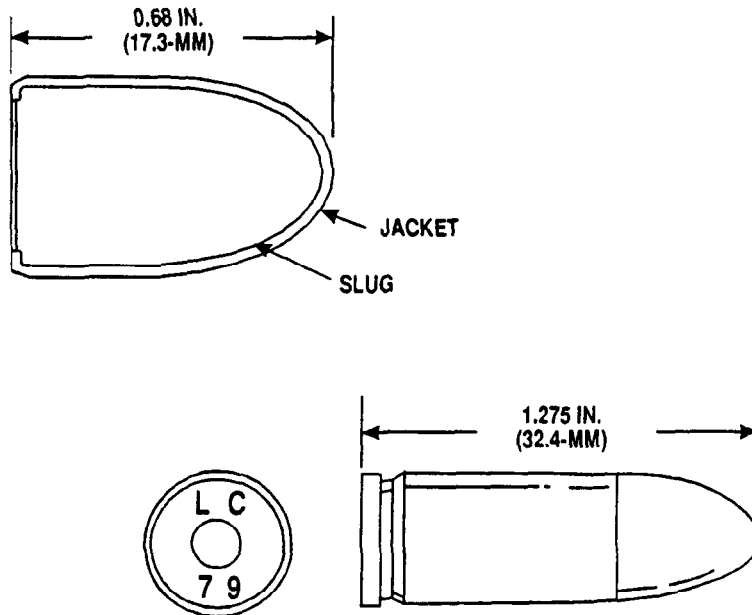

U
AR 5921

Type Classification:

STD - OTCM 36841.

Use:

Submachine Gun, Caliber .45, M3A1; and Pistol, Caliber .45, M1911A1. The cartridge is intended for use against personnel.

Description:

BALL Cartridge. The cartridge is identified by the plain bullet tip.

Tabulated Data:

DODAC-----	1305-A475
UNO serial number -----	0012
UNO proper shipping name-----	Cartridges for weapons, inert projectile
Weight -----	331 gr
Length-----	1.275 in. (32.4 mm)
Tracer-----	NA
Primer-----	Percussion
Fuze-----	NA

Explosive:

Type ----- NA
Weight----- NA

Incendiary:

Type ----- NA
Weight----- NA

Propellant:

Type ----- SR 7970
Weight----- 5 gr

Performance:

Chamber pressure ----- 19,000 psi
Velocity----- 885 ± 25 fps,
25.5 ft from muzzle

Shipping and Storage Data:

Quantity-distance class/ SCG -----	1.4S
Storage code -----	Class V
DOT shipping class -----	C
DOT designation -----	SMALL ARMS AMMUNITION
Drawing number -----	6000503

References:

SB 700-20
TM 9-1005-211-12
TM 9-1005-229-12
TM 9-1300-206

CARTRIDGE, CALIBER .45, BALL, MATCH, M1911

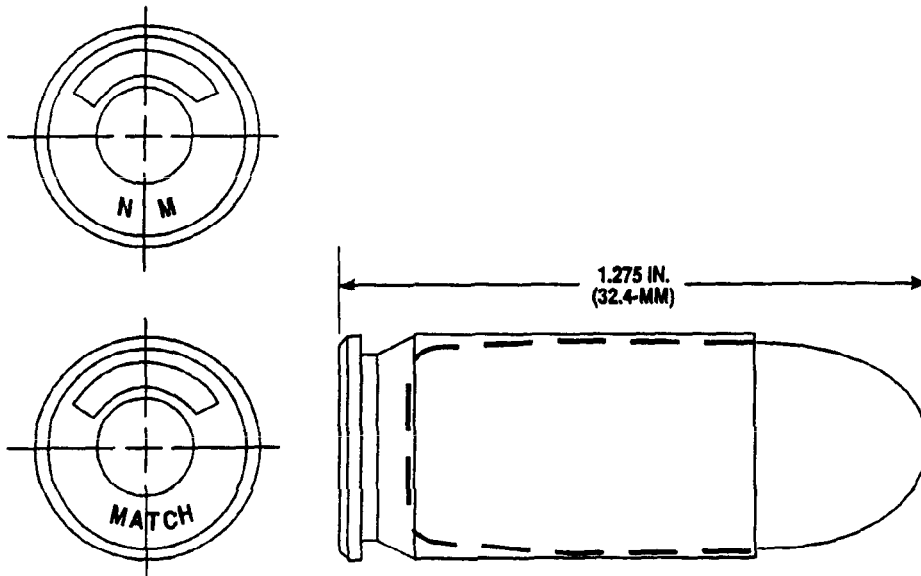

U
AR 5922

Type Classification:

STD - OTCM 36841.

Use:

Pistol, Caliber .45, M1911A1; and Pistol, Caliber .45, National Match. The cartridge is to be used only in those weapons designated as competition pistols.

Description:

BALL Cartridge. The cartridge is identified by head stampings, either NM (National Match) or MATCH, on the base of the cartridge case.

Tabulated Data:

DODAC----- 1305-A483
 UNO serial number ----- 0012
 UNO proper shipping name ----- Cartridges for weapons, inert projectile
 Weight ----- 334 gr
 Length ----- 1.275 in. (32.4 mm)
 Tracer ----- NA
 Primer ----- Percussion
 Fuze ----- NA

Explosive:

Type ----- NA
 Weight ----- NA

Incendiary:

Type ----- NA
 Weight ----- NA

Propellant:

Type ----- SR 7970
 Weight ----- 5 gr

Performance:

Chamber pressure ----- 19,000 psi
 Velocity ----- 885 ± 25 fps,
 25.5 ft from muzzle

Shipping and Storage Data:

Quantity-distance class/
 SCG ----- 1.4S
 Storage code ----- NA
 DOT shipping class ----- C
 DOT designation ----- SMALL ARMS
 AMMUNITION
 Drawing number ----- 8596136

References:

SB 700-20
 TM 9-1005-211-12
 TM 9-1300-206

