

# Improvised Apparatus

Every laboratory lacks some pieces of apparatus which are useful in conducting experiments in biology, chemistry or physics. And most laboratories do not have the equipment needed for student participation in these activities.

Since the science **curriculum** calls for a wide variety of pieces of apparatus which are not readily available to the teachers in the school, some teachers have taken it upon themselves to supply these articles temporarily until the supply can **catch** up with the demand. Necessity is the mother of invention and the **articles** presented here for your consideration are those which have sprung from such a **necessity**. In fact science has always been in this state,

and even in the most advanced countries science teachers are engaged in this type of work.

The articles given in this chapter are meant to introduce you to a wide variety of techniques which you will find useful when you strike out on your own to create a new piece of apparatus. But it is important to stress that this chapter in no way makes an attempt to exhaust all the ideas for apparatus which will be **useful** either to you in your teaching or for your students during **practicals**. The chapter was written, however, to give you an idea of the type and extent of things which **you** can do both easily and cheaply and which remain within the syllabus structure.

# STRAPPING BALANCE

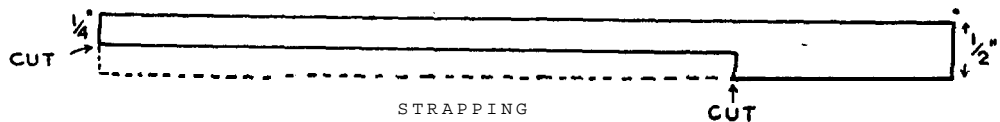
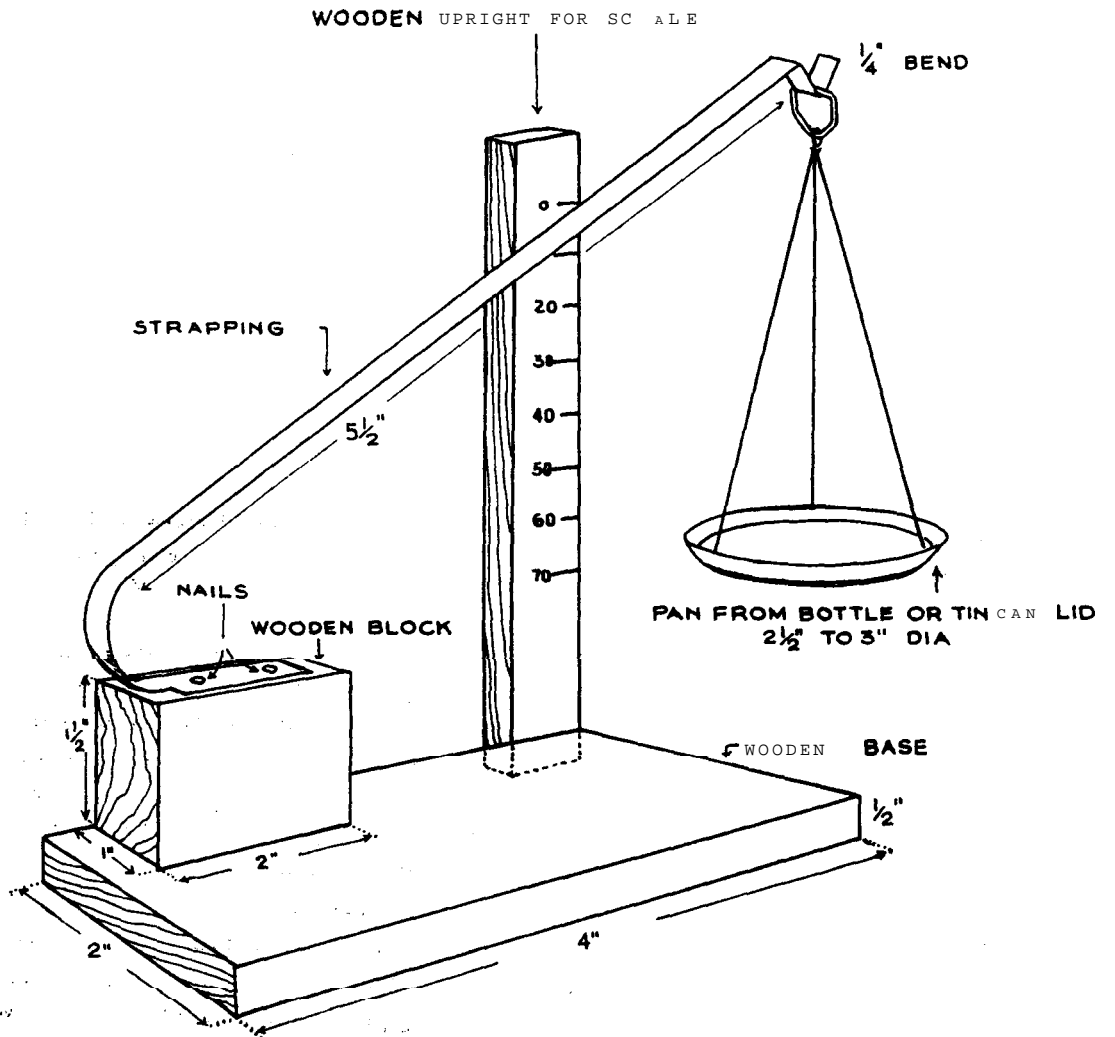

# STRAPPING BALANCE

## Materials required for construction

1.  $1\frac{1}{2}$ " X 2" X 4" wood base.
2.  $1\frac{1}{2}$ " X 1" X 2" wood block.
3.  $1\frac{1}{2}$ " X  $1\frac{1}{2}$ " X 5" wood scale.
4.  $\frac{1}{2}$ " wide strapping  $7\frac{1}{2}$ " long.
5. One tin can lid.
6. String.

## Procedure for construction

1. Nail the two wooden pieces (2 and 3 above) to the base as shown in the diagram. Attach a piece of graph paper to the wood scale.
2. Take the strapping and cut it in half for  $5\frac{1}{2}$ " of its length (see diagram).
3. Bend and fix it to the upper wood block as shown.
4. The last  $\frac{1}{4}$ " of its free end is to be bent in the form of a hook.
5. Make three holes in the lid equidistant from each other and tie the strings assembling as shown in the diagram.

## Calibration

1. Put a zero mark on the upright scale piece against the edge of the strapping.
2. Put 10 grams in the pan. Mark the position of the strapping.
3. Continue doing the same up to 70 grams.
4. If a graph paper is used on the scale piece, subdivisions can also be marked.

## Uses in practicals and demonstrations

This balance is useful only for rough measurements where accuracy is not absolutely essential. It can be useful in making quick measurements during

classroom demonstrations and **should** not be used where accuracy is required for a good demonstration or **experiment**.

# APPARATUS TO SHOW REFRACTION

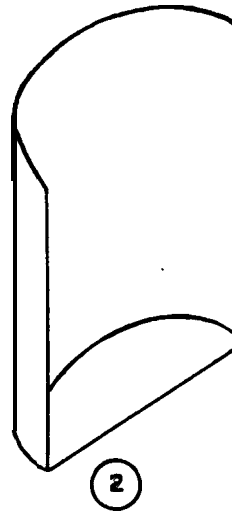
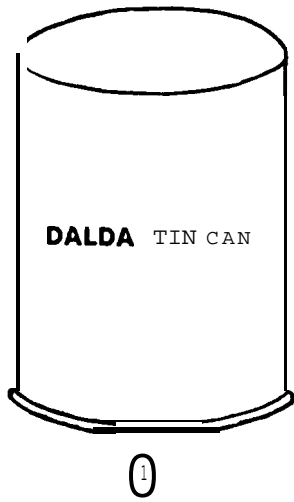

CUT THE TIN CAN IN HALF LENGTH-WISE

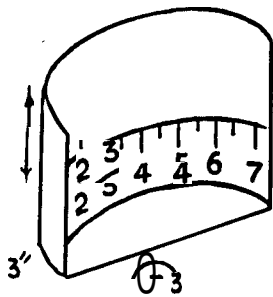

CUT THE HALF CAN TO 3" HEIGHT  
ATTACH A PAPER STRIP TO THE CURVED PART AND MARK **ARBITRARY DIVISION UNIT** AND COAT WITH WAX

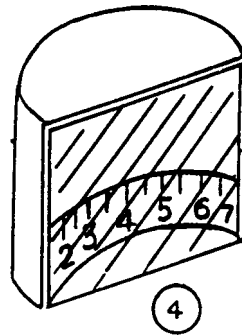

BEND THE EDGES TO HOLD A GLASS PLATE IN FRONT SEAL THE **JOINTS** INSIDE AND OUTSIDE WITH WAX

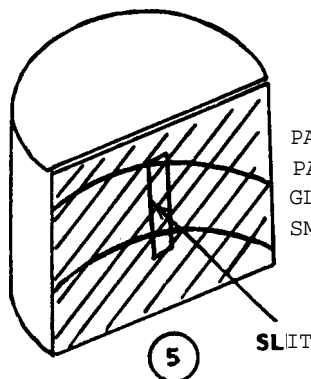

PASTE BLACK PAPER TO THE GLASS, LEAVING A SMALL SLIT IN FRONT

PATH OF THE RAY WHEN THERE IS NO WATER

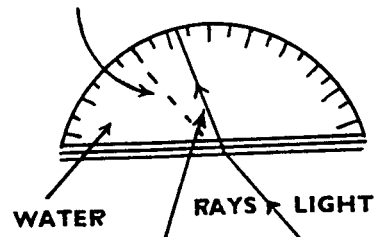

PATH OF THE RAY WHEN THERE IS WATER

TOP-VIEW

# APPARATUS TO SHOW REFRACTION

## Materials required for construction

1. One Dalda tin.
2. One glass plate.
3. Piece of black paper.
4. Graph paper.
5. Varnish.
6. Candle wax.

## Procedure for construction

1. Cut the tin in half lengthwise. Take one of these pieces and cut it so that it stands 3" high.
2. Attach a piece of graph paper marked in equal intervals to the inside wall of the tin along the bottom line. Varnish it.
3. Cut a glass piece to fit the front of the trough.
4. Bend the front edges of the trough slightly inwards to hold the glass piece.
5. Insert the glass piece and make waterproof by sealing it in place by using candle wax.
6. On the outside of the trough, cover the glass piece with a strip of black paper which has a vertical slit **along** its midline.

## Uses in practicals demonstrations

1. To demonstrate the refraction of light through various transparent substances.
2. To measure the refractive index of substances.

## Questions for further study

1. Take different transparent liquids in the trough and find their refractive index.
2. Is there any relationship between the refractive index and the density of the substance?
3. How can you demonstrate **differences** in refraction due to wavelength?
4. What procedures must the student go through to experimentally determine the refractive index of any transparent liquid?
5. Is there a relationship between the molarity of a solution and its refractive index?

## OPTICAL MICROMETER

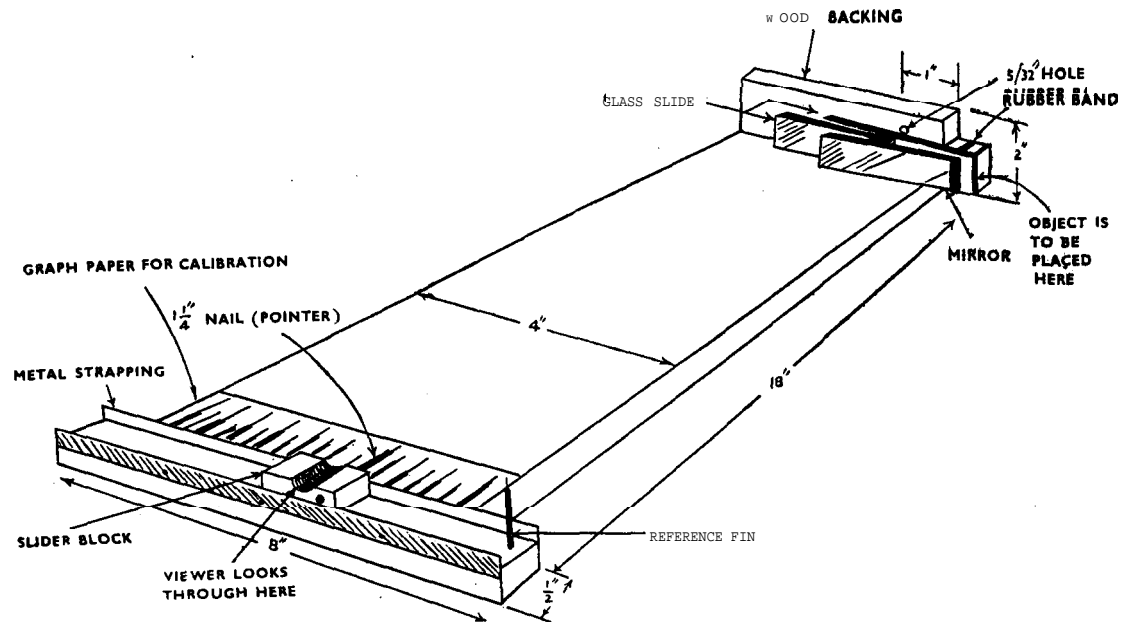

## OPTICAL MICROMETER

### Materials required for construction

1.  $1/2'' \times 1/2'' \times 2''$  wood piece.
2.  $1/2'' \times 1/2'' \times 8''$  wood piece.
3.  $1/2'' \times 4'' \times 18''$  wood piece.
4.  $1/4'' \times 2'' \times 4\frac{1}{2}''$  wood piece.
5. Graph paper.
6. Two thin glass slides  $1'' \times 3''$  each.
7. One small mirror  $1'' \times 2''$ .
8. Rubber band.
9.  $16''$  of metal strapping.
10. Nails  $1\frac{1}{4}''$  long for pointer on the slider block and reference pin. Smaller nails are used to attach wood pieces and strapping.

### Procedure for construction

1. Make the slider block from the  $1/2'' \times 1/2'' \times 2''$  wood piece. See diagram.
2. Nail the  $8''$  pieces of strapping to each side of the  $8''$  pieces of wood. Be sure about  $1/8$  of the strapping is above the wood to provide a groove for the slider block.
3. Attach this piece of wood to one of the  $4''$  sides of the  $18''$  piece of wood. See diagram.

4. Take the  $1/4'' \times 2'' \times 4\frac{1}{2}''$  piece and cut  $1/2''$  squares from both top and bottom of one of the 2'' sides leaving a  $1/2'' \times 1''$  "ear" in the middle of the side.
5. Line up glass slides on the top of "ear" even with edge. Drill a  $5/32''$  hole just above the glass slide. Locate this hole about 1'' to the left of the surface as shown in the diagram.
6. Attach this piece of wood to one end of the  $1/2'' \times 4'' \times 18''$  piece. Paint it black.
7. Fasten one of the slides to the wood with glue.
8. Fasten the second slide to the first. One end of the second slide should line up with the  $5/32''$  hole.
9. Then place the mirror on the slides with its reflecting **surface outside**. One end of the mirror should line up with the right hand edge of the first slide. Secure it with a rubber band.
10. Cut the head off a large nail and **fix** it on the right edge of the 8'' pieces of wood. See diagram.
11. Attach a strip of graph paper as shown in the diagram. Now the instrument is ready for calibration.

### Calibration

1. To find the zero point, look through the groove on the sliding block and move the block until the reflection of the reference pin is seen in the mirror exactly under the drilled hole which is above the glass slide. Mark this point on **the** graph paper.
2. Measure the thickness of a pad of paper. Then divide the thickness by the number of sheets of paper in the pad thus obtaining the thickness of one sheet.
3. Place one sheet between the mirror and glass slide. Move the slider and align the reference pin under the **hole** above the glass slide. Mark the **position** of the pointer on the graph paper.
4. Add sheets of paper one by one and mark the corresponding position of the slider on the graph paper.
5. Each division on the scale is subdivided suitably. This micrometer should be accurate to **0.002''**.

### Uses in **practicals** and demonstrations

1. To measure the thickness of **ex-**tremely thin objects.
2. To demonstrate a simple application of the laws of reflection.

## Notes on use and construction

After you demonstrate this piece, either in your science club or in **your class-room**, you may want to ask your student, questions like the following:

1. Explain the principles which govern the functioning of the optical **micro-meter**.
2. What operations must you perform to achieve good accuracy and sensitivity in the apparatus ?
3. The application of the same **principle** is used in some other experiments in physics. Can you mention them?

## OPTICAL BENCH

### Materials required for construction

1. Three  $1\frac{1}{2}$ " x 3" x 2" wood bases.
2. Scrap wood for lens height **adjustment**.
3. 3" x 10" cardboard.
4. Thin aluminium or tin.

### Procedure for construction

1. Cut the three wood bases and smooth with a rasp and sandpaper.
2. Screen **holder**: Apply two coats of varnish and allow to dry. Then attach the 3 x 10" cardboard screen with small tacks or nails.
3. **Candle holder** : With a tri-square and a ball point pen mark a centre line on the top and one side of the base as shown in the **diagram**.
4. **Lens holder** : From scrap wood make a small step on the base 1" high. To this, attach a "U" shaped lens **holder** bent from strapping as shown in the diagram. This holder should have a "V" shaped cross-section to prevent the lens from slipping. Put tape over the



# OPTICAL BENCH

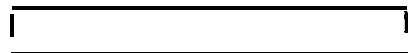
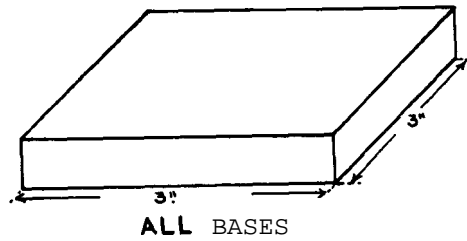
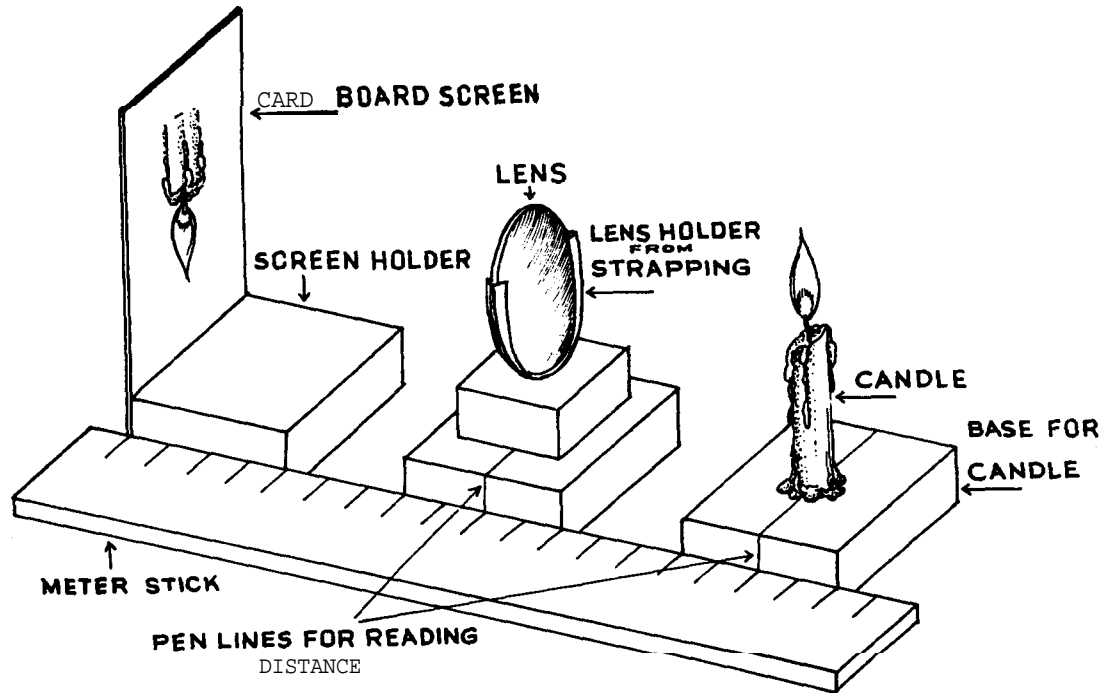

STRAPPING OR TIN



BEND THE STRAPPING AT THE ENDS IN TO V SHAPE

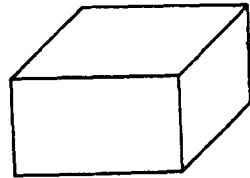

STAND FOR THE LENS HOLDER



BEND IT LIKE THIS

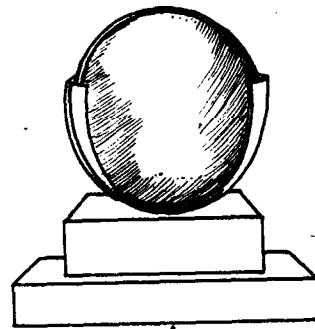

FRONT VIEW OF THE LENS STAND

strapping to prevent the lens from being scratched.

5. Mark the side of the base with a ball

pen to indicate the position of the centre of the lens and apply two coats of varnish.

### Uses **in practicals and demonstrations**

1. To find the focal lengths of small concave mirror and convex lenses.
2. To show the formation of different images when the lens is at different distances from the object.
3. To explore the relationship between “U” and “V”.

### Questions for further study

1. What improvement can you introduce in the apparatus to get a sharp image?
2. Can you explain the principle involved in a camera and a magic lantern by using the optical bench?
3. Given another lens and the optical bench, can you construct a telescope and a microscope? What are the conditions which are necessary? How can you find out the conditions using the simple optical bench?
4. Can you make the rays visible so that you can see how they converge and diverge?
5. How can you demonstrate magnification?
6. What is the relationship between the distance of the screen and the amount of magnification?
7. What is the relationship between the focal length of lenses and their magnification?

# S P R I N G   B A L A N C E

## Materials required for construction

1. **Four** feet of steel wire (weena string wire)
2. Bamboo piece 9" long.
3. Two tin pieces for top and bottom,
4. 14 gauge iron wire, **18"** long.
5. Test pan made from  $2\frac{1}{2}$ " diameter tin piece.

## Procedure for construction

1. **To** wind the wire spring, place the wire and a cylindrical metal object of a suitable diameter (about  $1/8$ " ) in the jaws of a drill machine. One person turns the drill winding the coils evenly while the other person keeps the wire under tension. When you are finished winding the wire, bend both ends into hooks.

2. Place the top end of the spring at the top of the bamboo tube and mark on the outside of the tube the position of the bottom of the unstretched spring. Then extend the spring to its maximum length without losing shape and mark

this position also. Connect these two points with a straight line.

3. Using the  $\frac{1}{4}$ " drill bit, drill holes at the first and second marks that you have just made. Continue drilling holes along the line at  $1\frac{1}{2}$ " intervals. By using a chisel, you can remove the remaining pieces between the holes being careful that you do not split the bamboo piece in two.

4. For the indicator, bend a **11"** piece of iron wire (14 gauge) in the shape illustrated. Tie the spring to the loop

JAWS OF THE VISE

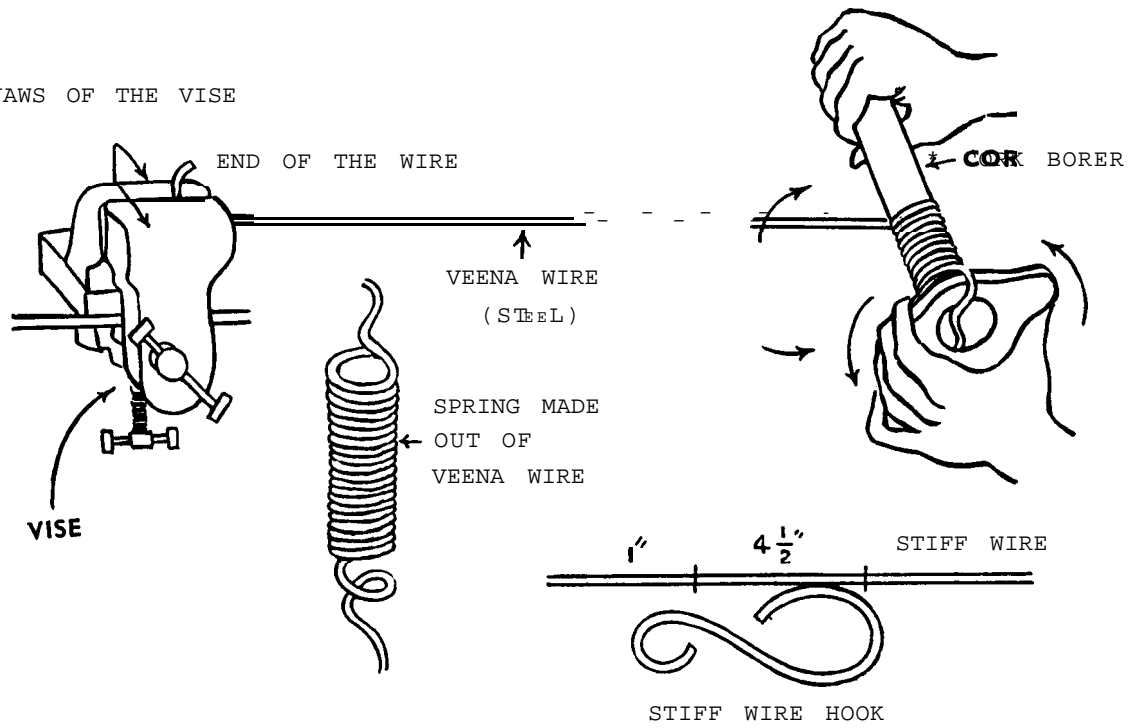

SPRING BALANCE

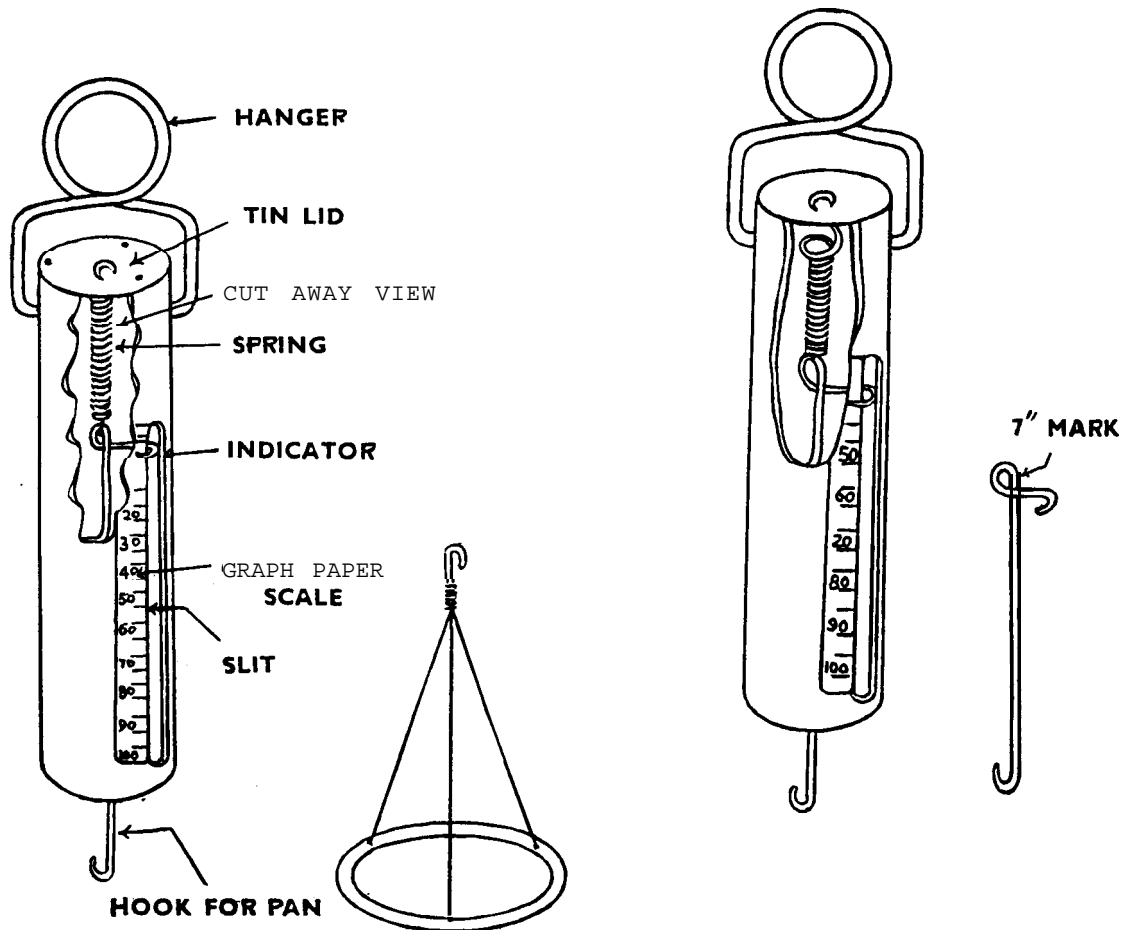

in the wire and insert the spring and wire into the bamboo tube. Tie the other end of the spring to the tin top and fix it to the bamboo tube with small nails. The **indicator** part of the wire should stick out of the slot. Bend it so that it is parallel to the top of the bamboo.

5. Drill a  $3/16$ " hole in the centre of the piece of tin that will be used for the base. Stick the wire through it and

fix the tin to the bamboo with pins. Bend the bottom of the wire into a hook.

6. Glue a strip of graph paper to the bamboo along the slit on the side to which the indicator points.

7. With standard weights, mark five gram divisions on the graph paper. Remember if you use a weighing pan, you must make the proper adjustments in your calculations.

### Uses in practicals and demonstrations

1. To illustrate Hook's Law.
2. To show the calibration of the spring balance.
3. To verify and apply **Archimedes'** principle
4. To measure forces while using the lever apparatus or the inclined plane.

### Questions for further study

1. By making springs from equal lengths of wire of different diameters, find the relationship between the distance of the extension and the amount of force required.

2. Take a rubber band equal in length to the spring balance and investigate how the extension varies in the spring and the rubber band for equal weights.

3. Since air is also an elastic material,

how can you design an "air spring **balance**" ?

4. Investigate the percentage error obtained in measuring weights with the "air" spring balance, the rubber band balance, the common balance and the spring balance.

5. By using wires of different materials but with equal diameters and lengths, investigate the nature of extension.

# SINGLE PAN BALANCE

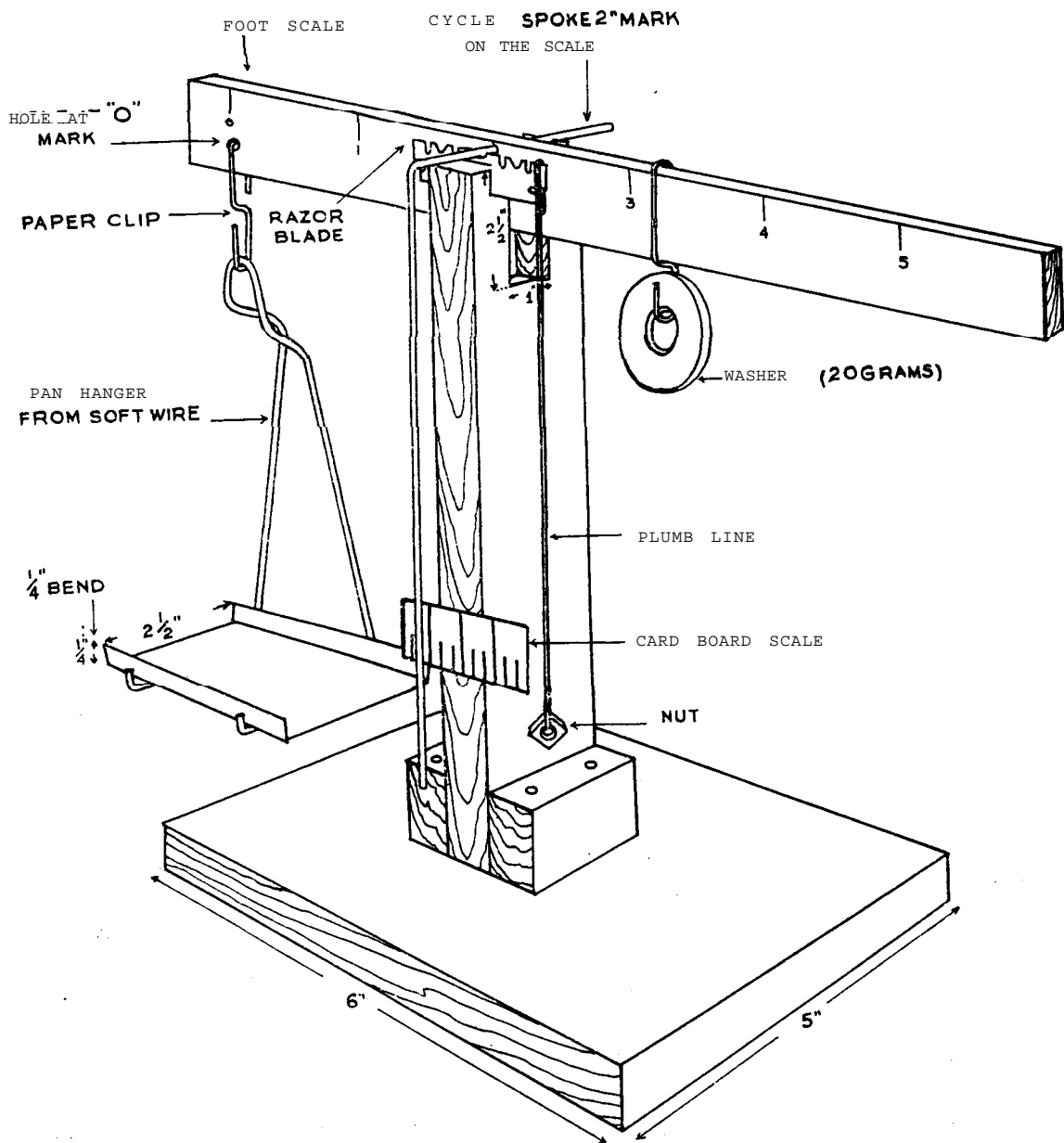

# SINGLE PAN BALANCE

## Material required for construction

1.  $1\frac{1}{2}'' \times 5'' \times 6''$  wood base.
2.  $1\frac{1}{2}'' \times 2\frac{1}{2}'' \times 7''$  wood upright.
3. One wooden foot scale.
4. Two  $1\frac{1}{2}'' \times 1\frac{1}{2}'' \times 2\frac{1}{2}''$  wood supports.
5. One cycle spoke.
6.  $12\frac{1}{2}''$  of heavy wire.
7. One razor blade.
8.  $3'' \times 3''$  tin piece.
9. Paper clips.
10. Washer or any other weight of 20 gms.
11. Thick broom stick.
12. Cardboard.

## Procedure for construction

1. Cut and sand all wood pieces.
2. Cut a notch  $2'' \times 1''$ ,  $1\frac{1}{4}''$  from either edge of the  $2\frac{1}{2}''$  side of the  $1\frac{1}{2}'' \times 2\frac{1}{2}'' \times 7''$  wood upright.
3. Varnish all wood pieces.
4. Drill a small hole at the  $2''$  mark of the foot scale just above the mid-longitudinal line.
5. Drill a  $1/10''$  hole at the zero mark just below the mid-longitudinal line of the foot scale.
6. Attach the upright to the base exactly at the base's centre. This is  $2\frac{3}{4}''$  from either edge of the  $5''$  side.
7. Nail the supports on each side of the bottom of the upright.
8. Push a  $4''$  piece of a cycle spoke through the hole at the  $2''$  mark on the foot scale. Secure it with sealing wax.
9. Attach the broomstick to the end of the cycle spoke which is at the front of the scaled part of the foot scale.
10. Cut notches in the two limbs of the upright about  $1.5''$  deep. See diagram.
11. Insert the razor blades into these slits and secure with sealing wax.
12. Straighten a paperclip, as shown in the diagram, to form a hook for the pan. Hang this hook from the hole at the zero mark on the foot scale.
13. Bend the heavy wire to form a pan hanger. See diagram.
14. From the tin piece, make a pan like that depicted in the diagram.
15. Attach the cardboard scale to the upright.
16. Balance the pan with a heavy washer kept at the  $4''$  mark on the free arm of the scale.
17. Suspend a small washer on a thread from the edge of the razor blade.

# SINGLEPAN BALANCE PARTS

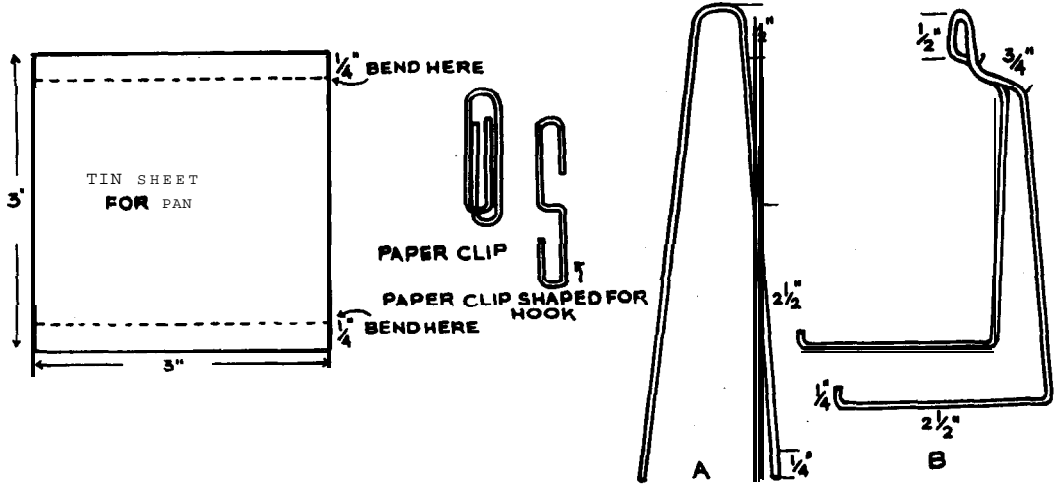
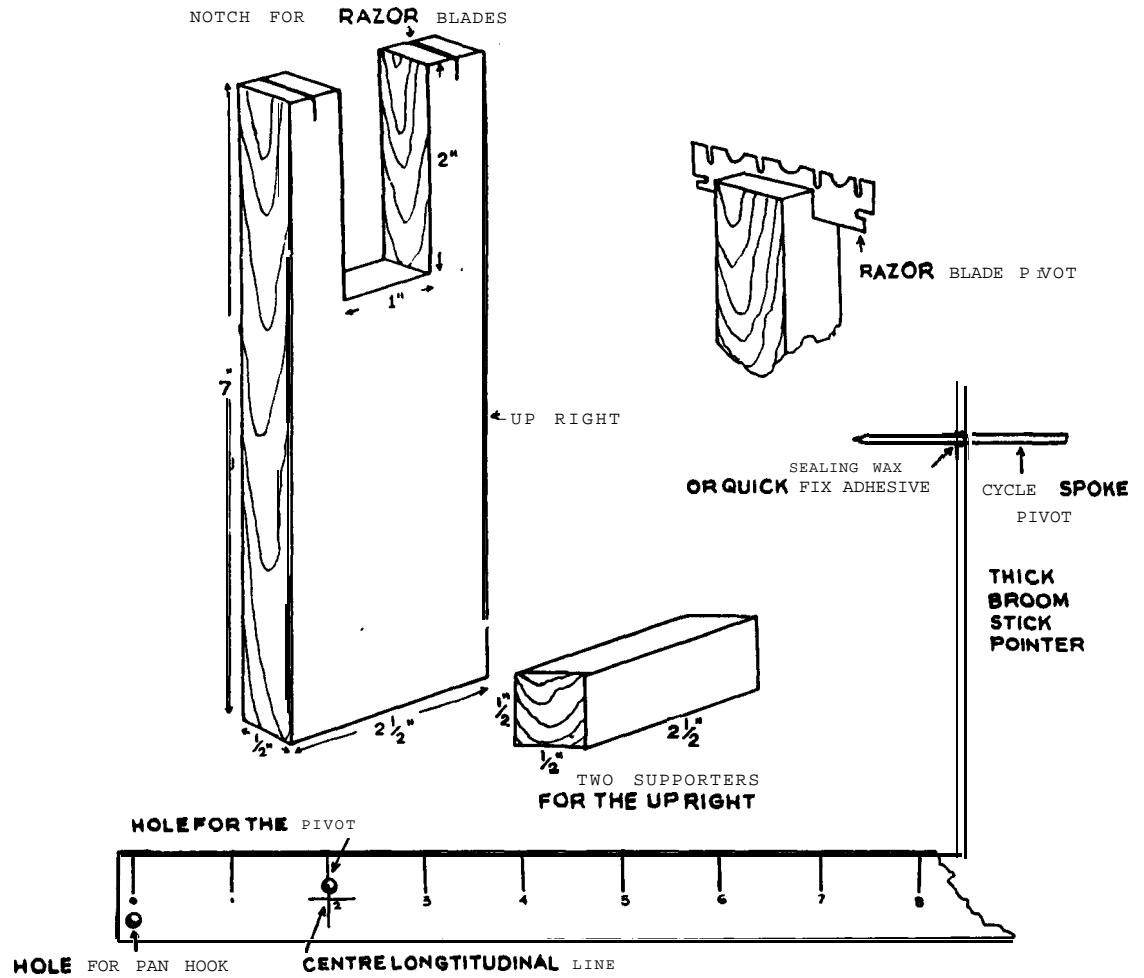



### Calibration

1. Glue a white slip of paper on the free arm of the scale.
2. Add 10 grams to the pan. Move the washer along the arm until it balances. Mark the position as "10".
3. Add 20 grams to the pan. Move the washer until the beam balances and mark it as "20".
4. Continue calibrating the rest of the beam in the same manner.

### Uses in **practicals** and demonstrations

This piece of apparatus is useful when weight boxes are not easily available or not available in sufficient number for a large group of students. It provides

cheap, quick and easy relief for such situations. It is also useful as a good exercise in using the principles of levers.

## LEVER APPARATUS

### Materials required for construction

1.  $1/2'' \times 1/2'' \times 24''$  wood bar.
2.  $1/2'' \times 3'' \times 4''$  wood base (from 3" stock).
3. Two  $1/2'' \times 1/2'' \times 6''$  wood uprights.
4.  $1/2'' \times 1/2''$  stock wood Brace piece (see 4 below).
5. One razor blade.

### Procedure for construction

1. Cut and sand the wooden pieces in 1, 2 and 3 above.
2. Make two cut-outs on the 4" sides of the base to receive the uprights. Make the cross-grain cuts with the saw and remove the remaining piece with the chisel.
3. From  $1/2'' \times 1/2''$  stock cut a brace piece of the proper length to fit between the uprights. Nail it in place approximately 1" from the top of the uprights.
4. Find the centre of the bar and drill a hole ABOVE the centre of gravity which will fit the 3" piece of wire. In-

# LEVER APPARATUS

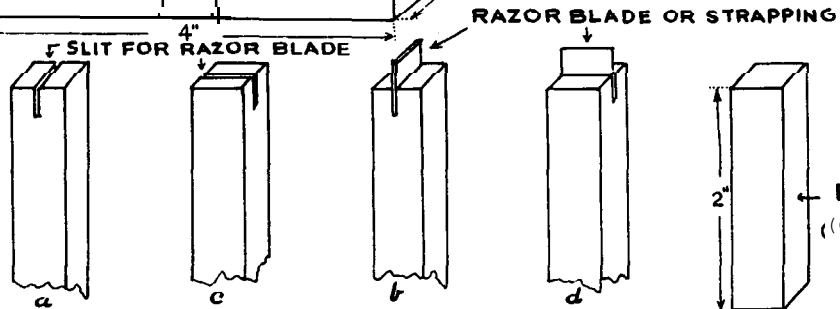
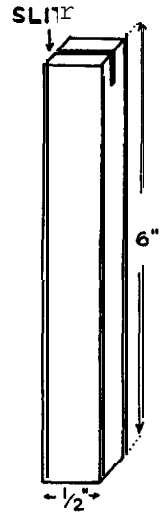
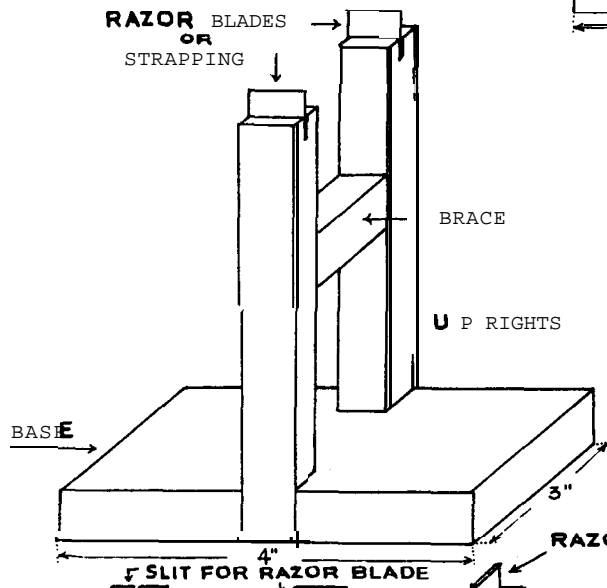
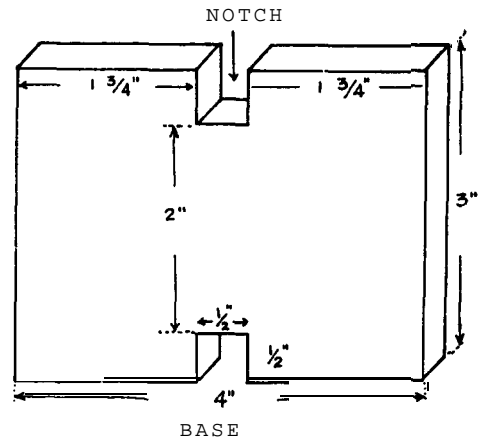
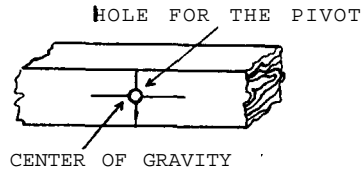
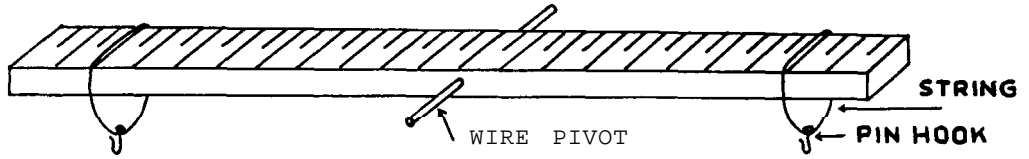

UP RIGHTS SHOWING HOW TO FIX RAZOR BLADE

**sert** the wire and make it fit tightly by using sealing wax.

5. Mark and number the bar in centimeters beginning from the **centre** and proceeding toward each end. The markings should be finished with a dark ball point pen.

6. Varnish **all** the wood pieces taking care that no varnish gets on the razor blade or the wire point. If, after varnishing, the bar does not balance exactly, attach a pin or a tack on the under-

neath side of the appropriate arm to make it level.

7. Weight holders may be made by attaching thread loops around the bar and hanging bent pin hooks from them.

8. Cut narrow slits in one end of each upright and insert the piece of razor blade into the slots fixing them to the upright with either glue or sealing wax and in such a **way** that they are both parallel and level. Nail the uprights to the base.

#### Uses in **practicals and demonstrations**

1. To demonstrate the principle of moments.
2. To demonstrate the three types of levers.
3. To do quantitative experiments on the lever.

#### **Questions for further study**

1. Why wouldn't the lever apparatus balance if the arm were placed upside down?

2. How can you use the apparatus as a equal arm balance?

3. How can you improve the sensitivity of such a balance?

4. How would you demonstrate the first law of levers? Draw a graph of

load vs. power arm. Draw conclusions.

5. How would you demonstrate the second law of levers? Draw a graph of load arm vs. power. What conclusions can you come to?

6. How would you demonstrate the third law of levers? Draw a graph of load arm vs. power. What conclusions can you draw?

# INCLINED PLANE

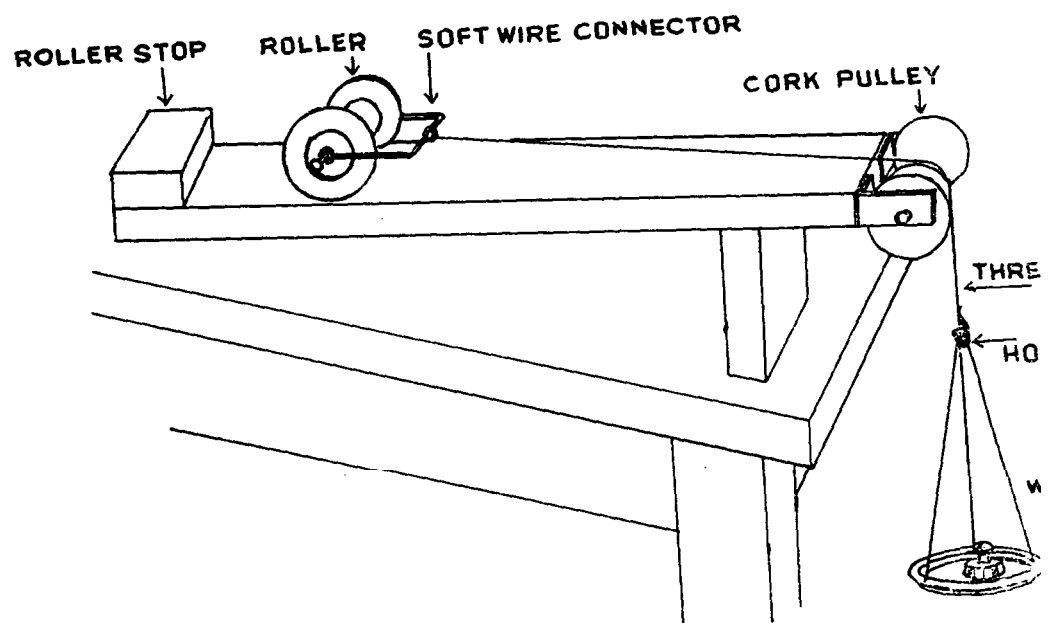
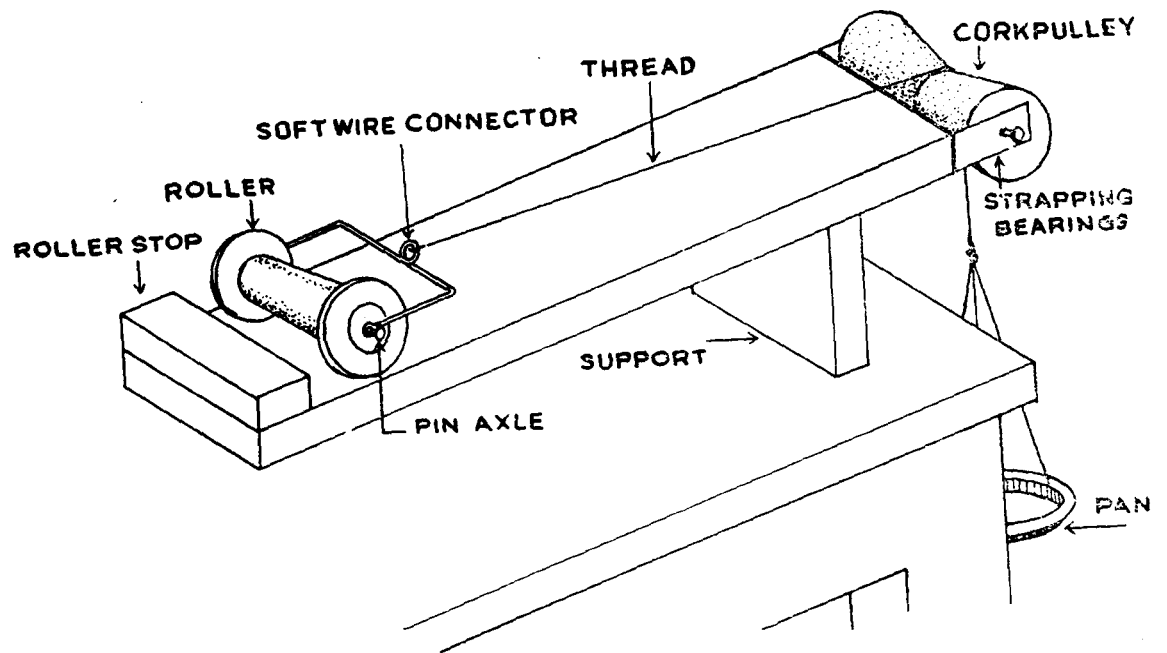

# INCLINED PLANE

## Materials required for construction

1.  $1/2'' \times 4'' \times 24''$  wood plane.
2.  $1/2'' \times 4'' \times 4''$  upright support.
3. Scrap  $4''$  stock  $1/2''$  to  $1''$  long for end stop.
4.  $8''$  of flexible copper wire,
5.  $2\frac{1}{2}''$  long pipe for roller.
6. Four  $1''$  corks.
7. Four straight pins.
8. Two  $2''$  pieces of strapping.

## Procedure for construction

1. Cut and sand carefully the  $24''$  wood plane.
2. Cut the upright support piece and nail it to the plane approximately  $1''$  from the end. Nail the roller stop piece at the other end. Apply two coats of varnish to this assembly and allow to dry.
3. *Roller:* Push corks into the ends of the  $2\frac{1}{2}''$  piece of pipe. Put straight pins into the centre of these corks leaving approximately  $1/4''$  sticking out. Make the connector for the roller from flexible copper wire and see the diagram for the proper shape. If the roller isn't heavy enough, you may fill the pipe with either lead shot or sand. Caution: If you fill the roller with sand, make sure that it is packed tightly leaving no empty spaces.
4. *Pulley:* Stick the small end of two corks together using sealing wax being careful to match the ends evenly. Push a straight pin into the centre of each cork leaving  $3/8''$  to  $1/2''$  sticking out. Cut-off the heads. Make two pulley holders from strapping, shaping them as shown in the diagram. Fix them to the centre of the end of the plane with just enough space between them to fit in the cork pulley. The cork pulley should rotate freely and not touch the pulley holders. For this reason, the cork ends of the cork pulley should be filed as illustrated.
5. A weight pan may be made from scrap tin (for instance from the top of a kerosene tin). Use light thread and a hook made from a straight pin to attach the weight pan to the roller assembly.

## Uses in practicals and demonstrations

1. To demonstrate the working principle of an inclined plane using the spring balance.
2. To find the relationship between the ratio of weight and power to the length and height of the plane.
3. To illustrate quantitatively and qualitatively the mechanical advantage of the inclined plane.

# DETAIL OF PULLEY & PULLEY HOLDER

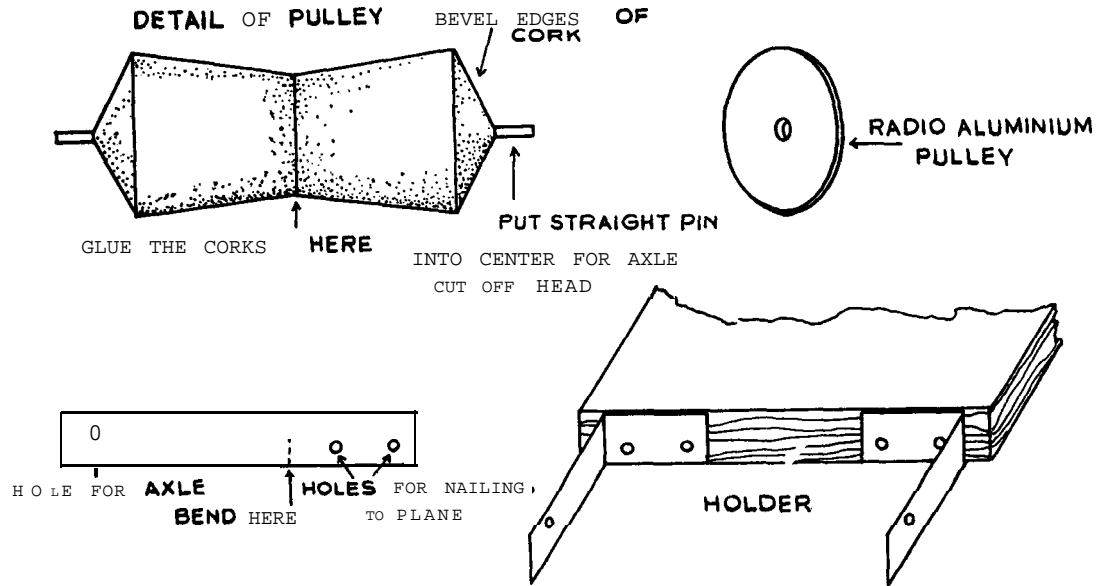

## ROLLERS

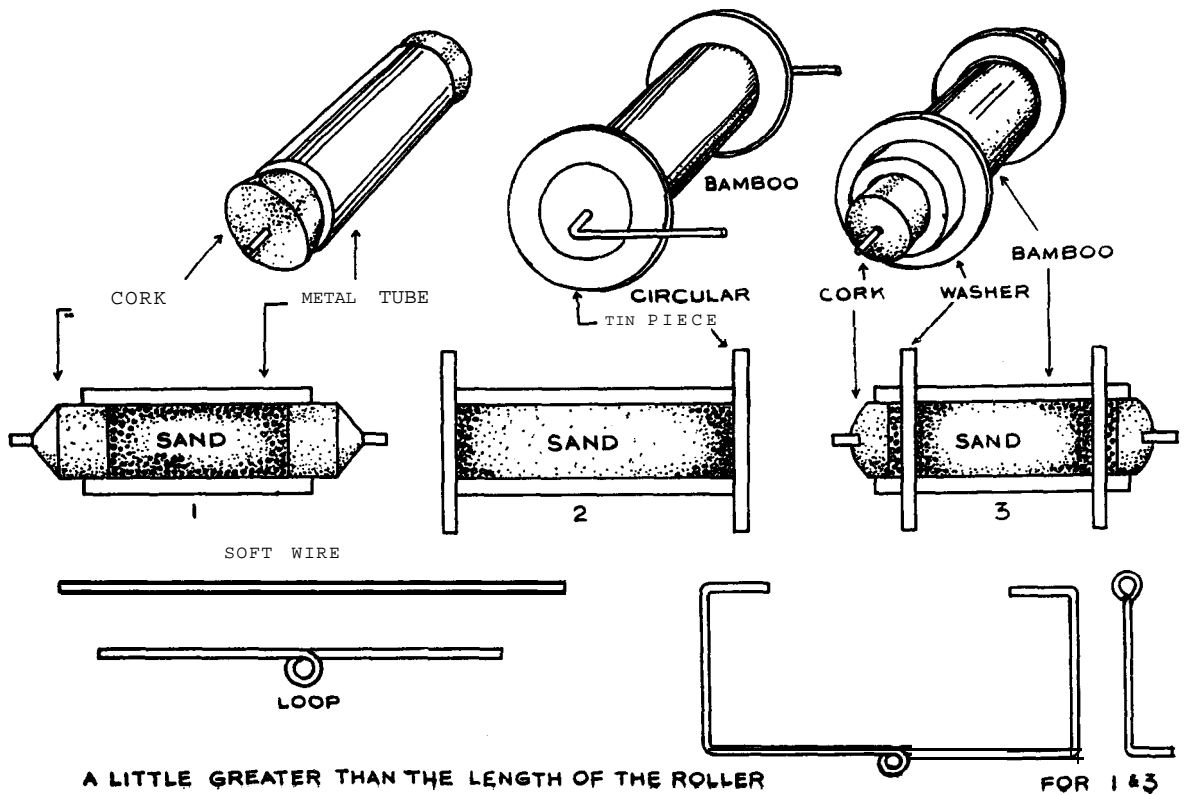

### Questions for further study

1. Derive experimentally the formula for the mechanical advantage of the inclined plane.
2. Find the relationship between the ratio of weight and power to the length and height of the plane.
3. Why should the pulley be made out of cork or light metal?
4. Where can you apply the principle of the inclined plane?
5. You will see sign boards by the side of the railway track— $1/100$  or  $1/1000$  or  $1/5$  etc. What do they signify?
6. How can you achieve maximum mechanical advantage in laying a road uphill?
7. What is the relationship between the angle of the plane and the acceleration of the pulley when it is falling?

## CELL HOLDER AND SWITCH

### Materials required for construction

1.  $1/2'' \times 3'' \times 10''$  wood base
2. Four  $2''$  pieces of metal strapping.
3. Three bolts with six nuts and six washers.
4.  $4\frac{1}{4}'' \times 5''$  piece of heavy paper.
5.  $4''$  piece of medium wire.

### Procedure for construction

1. Bend two of the pieces of metal strapping almost into right angles, with the apex of the angle at the centre.
2. Drill holes in one end of each to receive the small bolts.

# CELL HOLDER and SWITCH

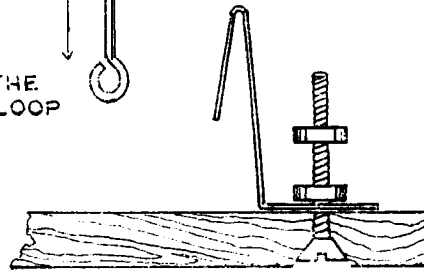
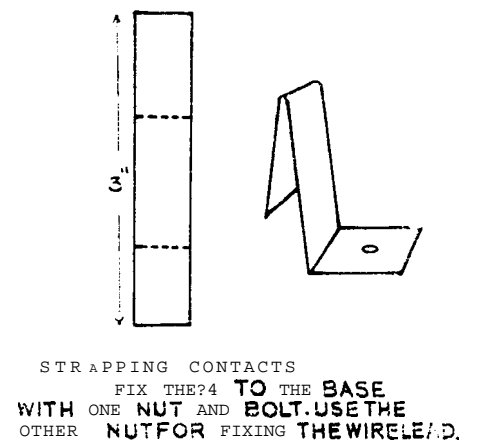
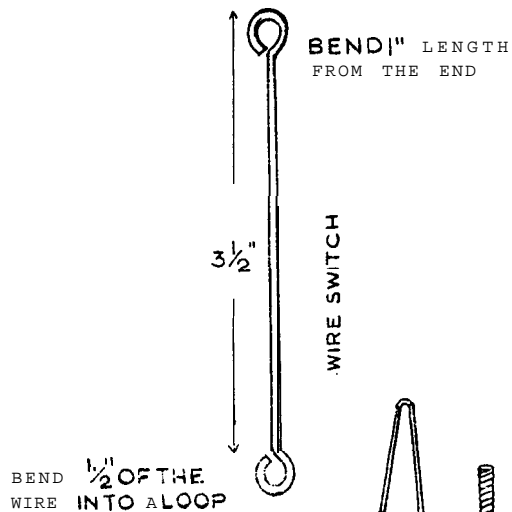
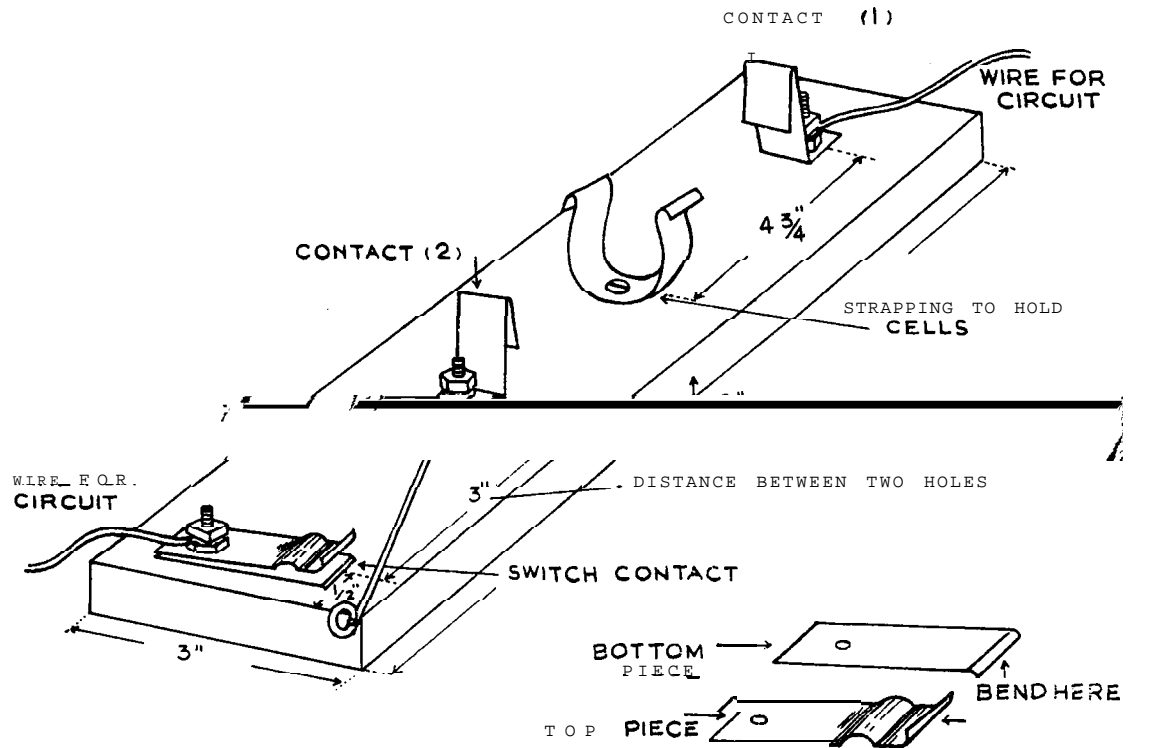

HOW TO FIX A CONTACT



3. Beginning at one end of the base, measure off  $\frac{3}{4}$ ". From this point measure off  $4\frac{3}{4}$ ", the length of two standard "D" size cells. Drill two holes in the base so that the two "L" shaped contacts may be attached by the holes leaving  $4\frac{3}{4}$ " between them.

4. Approximately 2" from the second contact, drill another hole in the base to attach the contact for the switch. This contact is made from a short, straight piece of strapping bent up at one end. It should be drilled to receive a small bolt.

5. Bend the switch handle from large, stiff wire. The fixed end of the switch is to be attached to the base with the same bolt used to hold the second "L" shaped contact.

6. Apply two coats of varnish to the base.

7. When dry, attach the metal pieces to the board with three small bolts. The heads of the bolts should be on the bottom side of the base and a large drill may be used to make a hole to counter-sink the bolt heads.

8. Wrap a heavy piece of paper around the two cells, making sure it does not come all the way to the ends. Secure the paper with a small piece of adhesive plaster. This tube will keep the cells from slipping out of the holder.

9. Slight adjustment of the "L" shaped contacts may be necessary to get a good connection.

### Uses in practicals and demonstrations

To provide convenient mounting and terminals for two standard torch cells

and a switch for connecting them in a circuit.

### Notes on use and construction

Be sure that you sand the contact surfaces before use. Rust will build up quickly and insulate these surfaces. It is best if after use you wipe all surfaces

clean. Rust will build up much less quickly if you keep these surfaces free from perspiration,

## OVERFLOW JAR

### Materials required for construction

1. One squash bottle.
2. One cork to fit the bottle's mouth.
3. 8" of glass tubing.

## OVERFLOW JAR

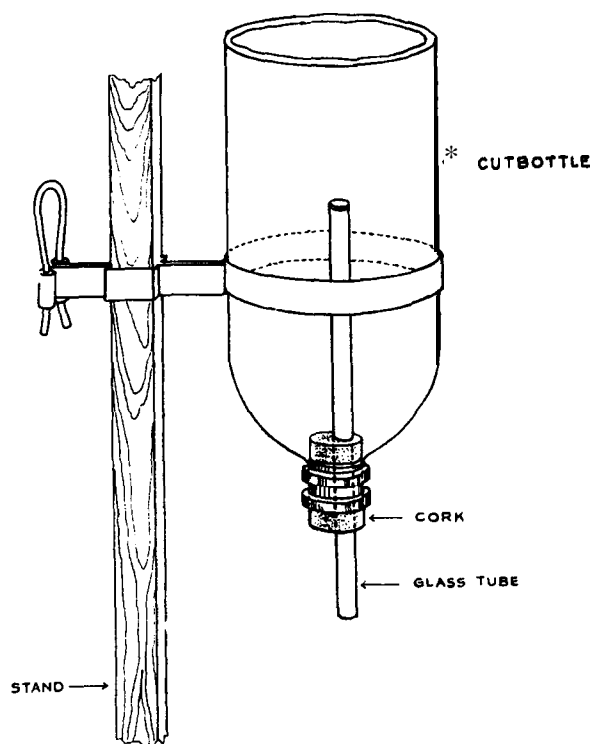

### Procedure for construction

1. Cut off the bottom of the bottle-
2. Bore a hole in the cork to one side, not at the centre.
3. Fit the cork to the neck of the bottle.
4. Introduce the glass tube in it. The end part of the tube that is inside the bottle should be  $\frac{1}{2}$ " below the cut bottom.

### Uses in practicals and demonstrations

1. To measure the volume of irregular bodies which don't fit into the graduated cylinder.
2. To collect the water displaced by bodies in experiments concerning the laws of flotation or Archimedes' principle.

# RAO'S BOTTLE

## Materials required for construction

1. A bottle with a narrow neck.
2. One-holed cork to fit the neck of the bottle.
3. One glass tube, longer than the height of the bottle.
4. Turpentine and camphor mixture.

## Procedure for construction

1. Mark three equidistant points in a line, parallel to the longitudinal axis of the bottle. See diagram.
2. Put a drop of turpentine camphor mixture on one mark.
3. Chip off the end of a triangular file.
4. Take the small piece and use one of its pointed corners to bore a hole where you placed the turpentine camphor mixture.
5. Slowly apply pressure and drill until a very **small** hole is made in the bottle. Its diameter should be **approximately** 1 mm.
6. Repeat the procedure for the other two holes.
7. Wash the bottle and put pieces of broomsticks in the holes to serve as **plugs**.

## Uses in practicals and demonstrations

1 This piece provides a constant flow of water and can be used in conjunction with the water timer.

2. It also is a useful demonstration when teaching pressure because when the three holes are unplugged simultaneously, water will flow out hole "C". There will be no flow out hole "B" and air will be taken in, bubbling through the water at hole "A".

### RAO'S BOTTLE

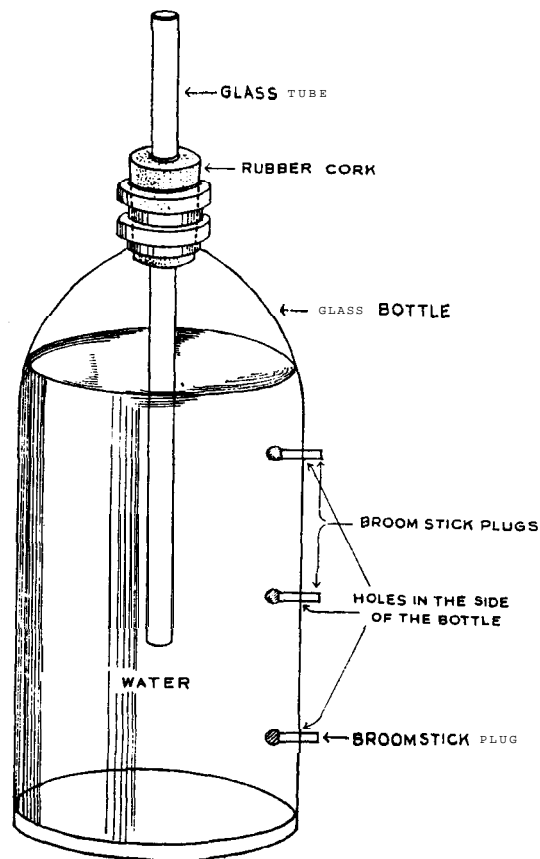

#### Notes on use and construction

Ask your students what will happen if you unplug hole "A", hole "B", and hole "C"? why? After you get their opinions and reasons, try the following experiment. If you unplug hole "C" water will flow out, due to the outward pressure of the column at point "C" (which is greater than the atmospheric pressure inwards). If you unplug only hole "B", there should be no motion; this is because water flowing out hole "B" must be replaced in the bottle by water from the glass tube. But if this happens, the column of water inside the glass tube is shorter than the column outside the tube. The upward pressure at the bottom of the tube (resulting from the column of water in the bottle) would be greater than the downward pressure from the column inside the tube, forcing the water in the tube back

up. Therefore, water cannot flow out "B". If you unplug only "A" there will also be no flow. This is for the same reason-any loss of water through "A" must force a drop of water level in the tube creating the loss of downward

pressure at the bottom of the tube. Since the upward water pressure at that point remains constant due to the column of water in the bottle, water cannot come out from the tube. Thus there is no leakage at "A".

## COMMON BALANCE

"EXPLODED" 3 DIMENSIONAL VIEW

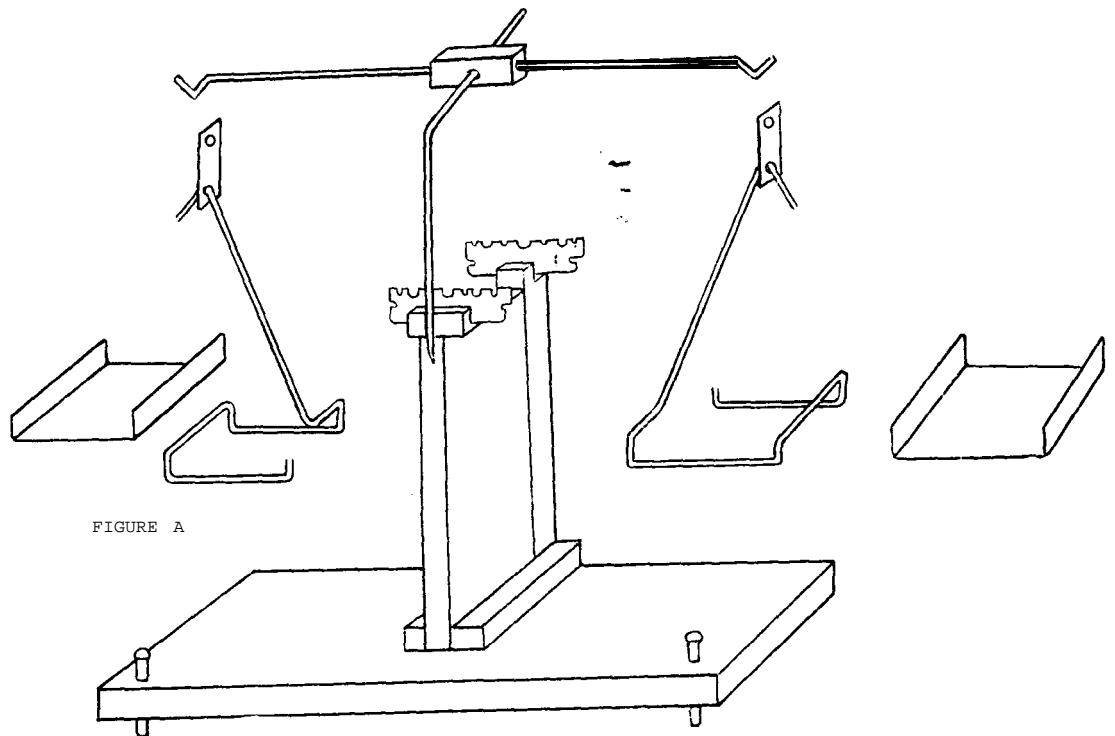

FIGURE A

## THE COMMON BALANCE

Materials required for construction

1. 1" x 4" x 10" wood piece.
2. 1" x 3 x 7½" wood piece.
3. Two 1" x 1" x 3" (approximate) wood pieces.
4. 1/2" x 1" x 2½" wood piece.
5. Two cycle spokes.
6. One large sewing needle.
7. One razor blade.
8. Tin.
9. 16 gauge iron wire.
10. Two 3/16" bolts 1½" long.
11. One broomstick.

COMMON BALANCE

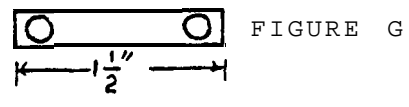
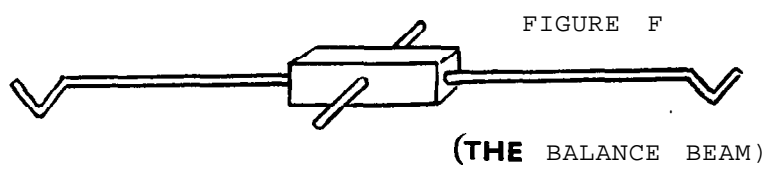
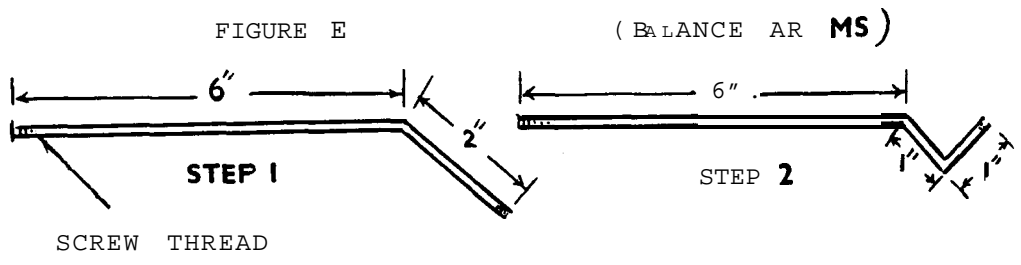
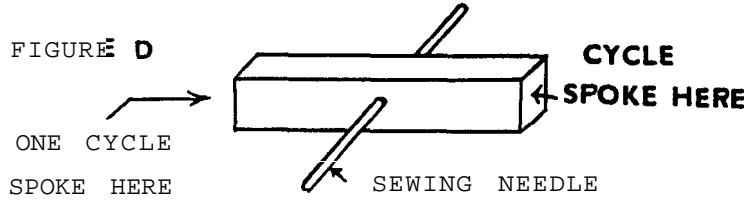
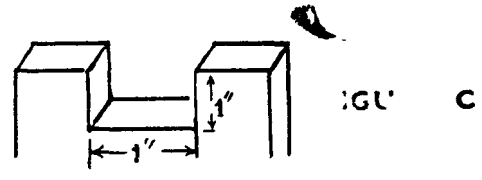
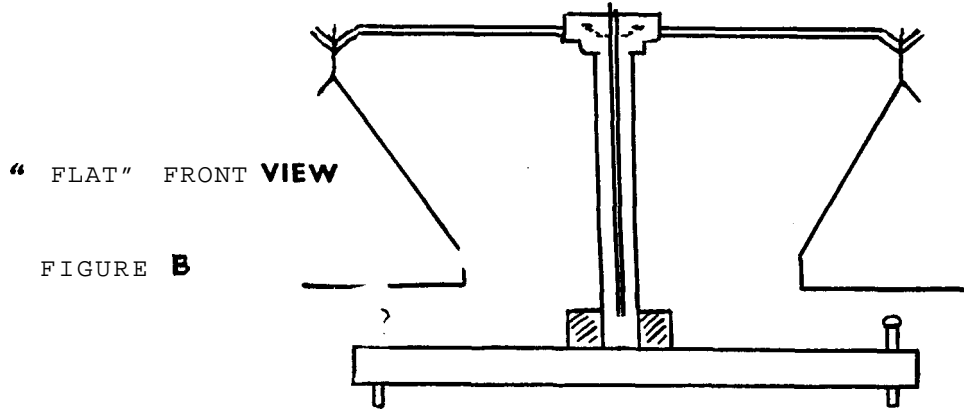

## Procedure for **construction**

1. Cut and sand the wood pieces. Take the upright piece ( $1'' \times 3'' \times 7\frac{1}{2}''$ ) and cut a notch in the centre of one end. The notch should be  $1''$  deep and  $1''$  wide.
2. Nail the upright across the centre of the base, such that the back edge of the upright meets the back edge of the base. This should leave about  $1''$  between the front of the upright and the front edge of the base.
3. Fasten the  $1'' \times 1'' \times 3''$  pieces as braces on each side of the upright. (See diagram and check the accuracy of your work to this point).
4. Varnish the assembly.
5. In the  $\frac{1}{2}'' \times 1'' \times 2\frac{1}{2}''$  piece, drill a hole the proper size to fit the sewing needle very tightly. This hole should be just above the centre of gravity of the wood **piece**. The closer the fulcrum (that is, the needle) is to the centre of gravity, the more sensitive will be the balance. This hole also must be exactly perpendicular (normal) to the  $1'' \times 2\frac{1}{2}''$  faces of the wood **piece**. (See diagram)
6. In the ends of this same piece in a line just slightly lower than the fulcrum, drill two holes with a pointed piece of cycle spoke (which can be sharpened with the triangular file). Make the holes each about  $\frac{3}{4}''$  deep. Into these holes you will screw the arms (the two cycle spokes) of the balance beam. (See diagram).
7. From each cycle spoke cut an  $8''$  length, making sure the threaded end of the spokes are part of this  $8''$  length. **Bend** each piece as shown in the diagram.
8. Screw these two "arms" into the holes in the ends of the fulcrum block. Make sure that the points of suspension of the weight pans are exactly equal lengths from the needle fulcrum. (You can test for this after the balance is completed.)
9. Cut two tin pieces into the "I" shape shown (see diagram). Make each one about  $1\frac{1}{2}''$  long and  $\frac{1}{2}''$  wide. Then drill two  $\frac{3}{16}''$  holes at each end of both pieces.
10. Bend two lengths of wire, each  $16$  long, as shown in the diagram. These bent wires will serve as weight pan holders.
11. Cut two  $3\frac{1}{2}''$  squares from a tin sheet. Bend each as shown in the diagram. These weight pans should fit snugly into the wire pan holders.
12. Cut a razor blade in half, lengthwise.
13. Fix each half blade into the top of the upright. Be sure the blades are no farther apart than the length of the needle fulcrum. Also the centre notch of each blade must be directly in line with the other across the  $1'' \times 11''$  notch in the upright.
14. Drill  $\frac{3}{16}''$  holes near the front left and front right corners of the base. Keep each hole about  $\frac{1}{2}''$  from the ends and front edge of the base. Widen the hole at the bottom allowing the nuts to be countersunk and held in place. These can be kept in place by nailing tin sheets over them. By turning the bolt in these two nuts you can adjust the balance so that it is level.

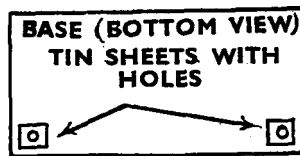
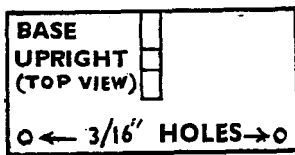
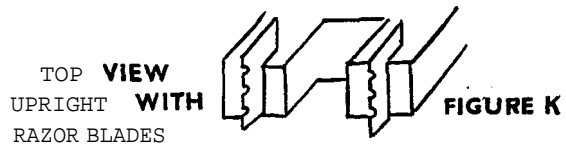
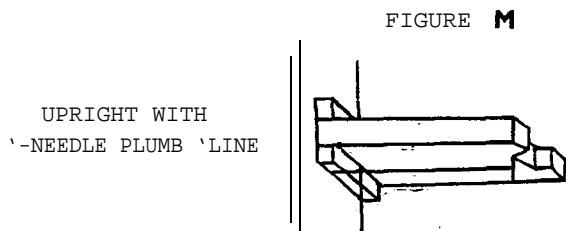
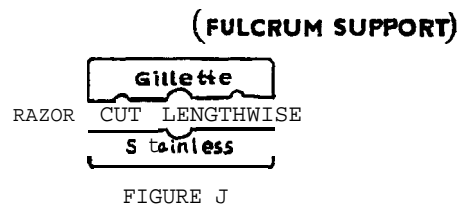
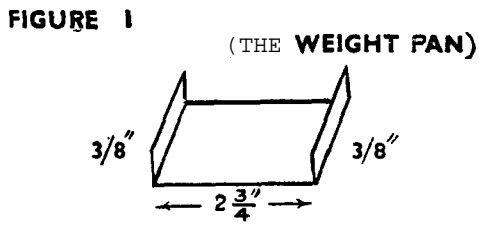
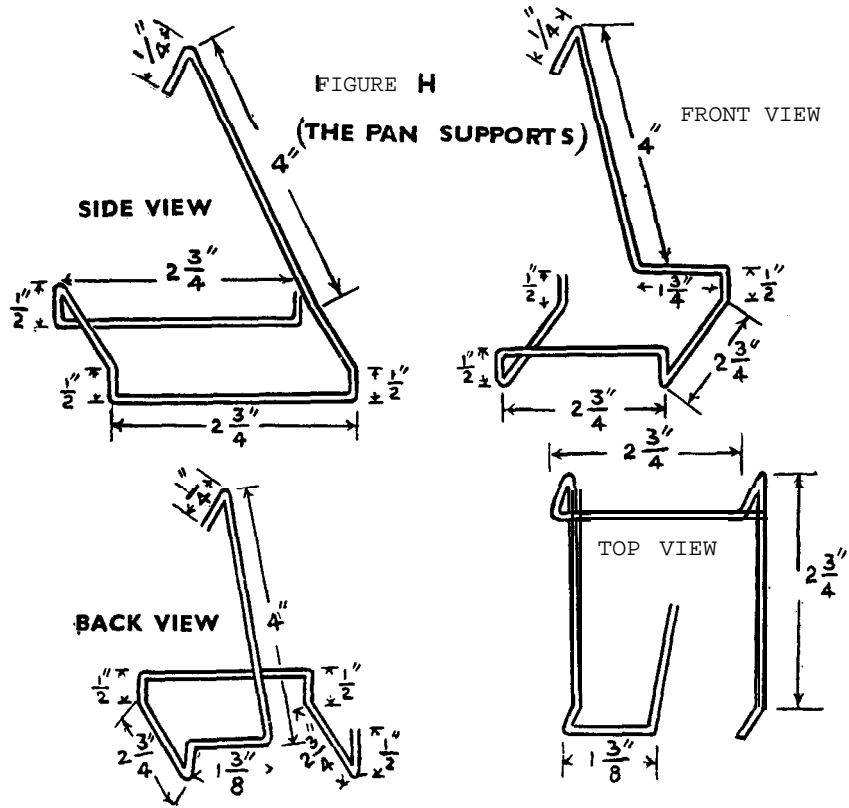

FIGURE L



**15.** For the third leg of the base, hammer a nail into the bottom of the base at the centre rear of the base. Leave about 1/2" of the nail free to act as a leg.

16. Near the front of the upright on the top right hand side, fix a nail that extends 3/4" from the upright surface. Hang a thread with a needle at its end from this nail. Find the exact length of the point of suspension of the thread from the right face of the upright and from the back of the balance. In the base of the balance at a point exactly the same lengths from the upright and from the back of the balance fix a nail up through the base pointing upwards. The nail should extend about 1/2" above the base.

When the needle hangs directly above this nail, the balance is level. This is done by turning the adjusting screws in the forward corners of the base.

**17.** The needle serving as the fulcrum should be long enough to extend somewhat past the front of the upright. Fix it such that the "eye" of the needle points to the front of the balance. Stick a pin through the needle eye and fix a broomstick to it. See that the needle is positioned such that the stick is exactly perpendicular to the arms of the common balance.

18. Fix a scale of the front of the upright near the broomstick point.

#### To insure proper balance

After suspending the weight pans from the balance arms and putting a scale at the base of the upright, you must see that the arms are of equal length. Temporarily balance the apparatus by addition of some weights to the lighter side. After temporarily balancing, put two exactly equal masses in each pan. If the pointer remains at zero, then the arms are equal. If not, the lower arm is too long and you can either (1) screw the longer arm further into the fulcrum block or (2) screw the shorter one out slightly. Then repeat the procedure with equal masses in each weight pan, **untill** the arms are equal. Then you can permanently balance it with empty weight pans by either (1) cutting some material from the heavier weight pan or (2) removing some wire from the heavier wire pan holder. Finally, hang a 2" or 3" piece of wire from one arm. It will serve as a fine balancing adjustment

#### Questions for further study

1. Why should the fulcrum for the balance arm be above the centre of gravity?

2. How can you make this balance more sensitive?

3. What function does the plumb line

serve? If this was ignored when adjusting the balance, how would error be introduced?

4. What is the purpose of free swinging pans?

# WATER TIMER

PERSPECTIVE VIEW

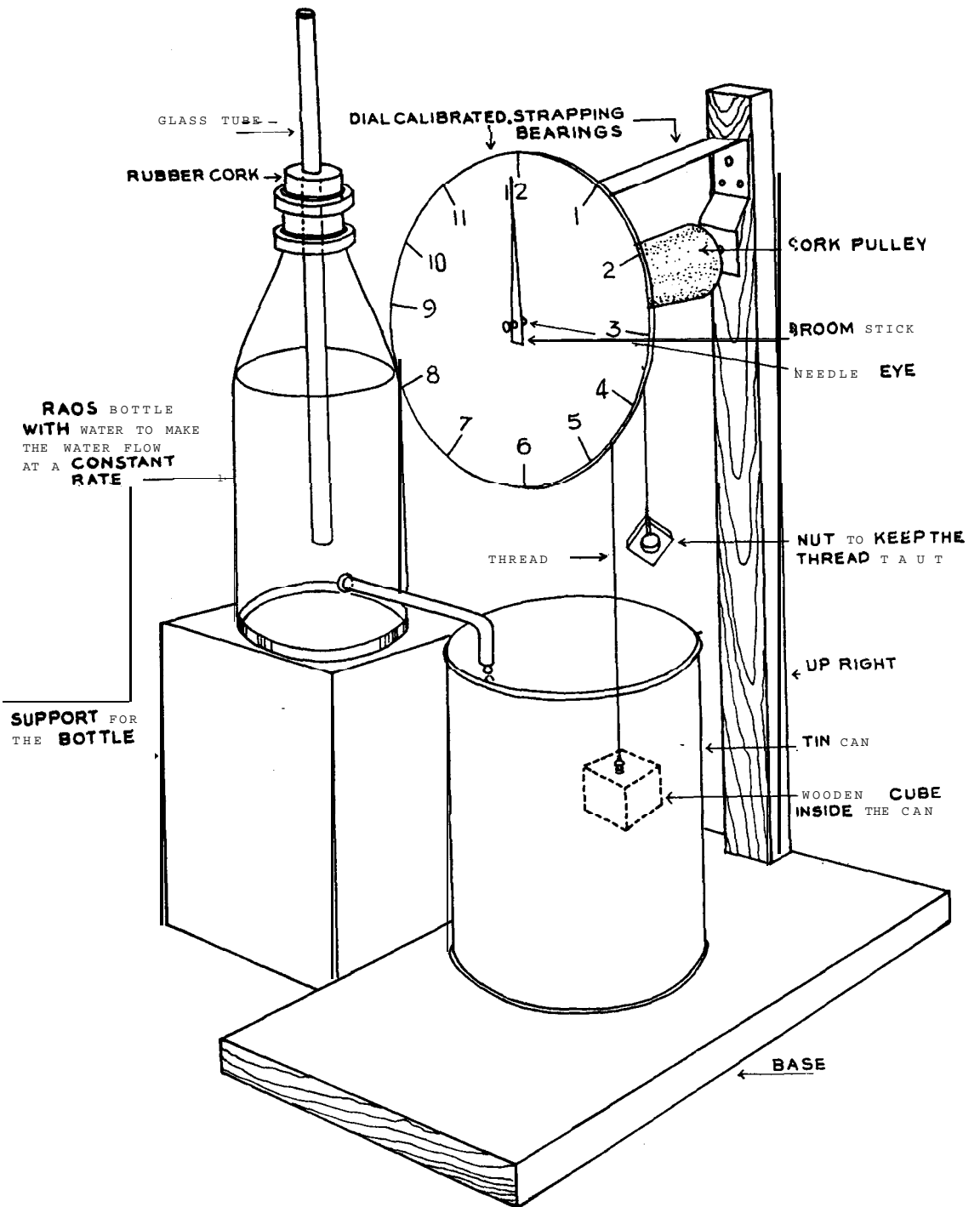

# W A T E R   T I M E R

## Materials required for construction

1. **One** small wooden cube.
2. One eye screw.
3. string.
- 4 Two **small** corks.
5. Cardboard.
6. 6" knitting needle.
7.  $1\frac{1}{2}$ " x 4" x 6" wooden base.
8.  $1\frac{1}{2}$ " x  $1\frac{1}{2}$ " x 24" **wooden** upright
9. Strapping.
10. Tin, 3" diameter and 12" high.
11. Rao's bottle.

## Procedure for construction

1. Cut and sand the base and upright and fix together as shown in the diagram.  
two corks. This serves as the axle of the cork pulley. Fix this pulley in the strapping.
2. Bend the piece of strapping in the shape of a "U". Punch holes  $\frac{3}{10}$ " away from the ends. Fix it to the upright.
3. Glue the narrow ends of the corks together (sealing wax may be used).
4. Drive the knitting needle right through the centre of the faces of the
5. Put the screw eye into the wooden cube and tie the string to the screw eye. Tie a nut to the other end of the string to keep the string taut when it is passed over the pulley.
6. Put the tin can on the base close to the upright and put the wooden cube on it.
7. Arrange **Rao's bottle** in such a way

# WATER TIMER

PERSPECTIVE VIEW

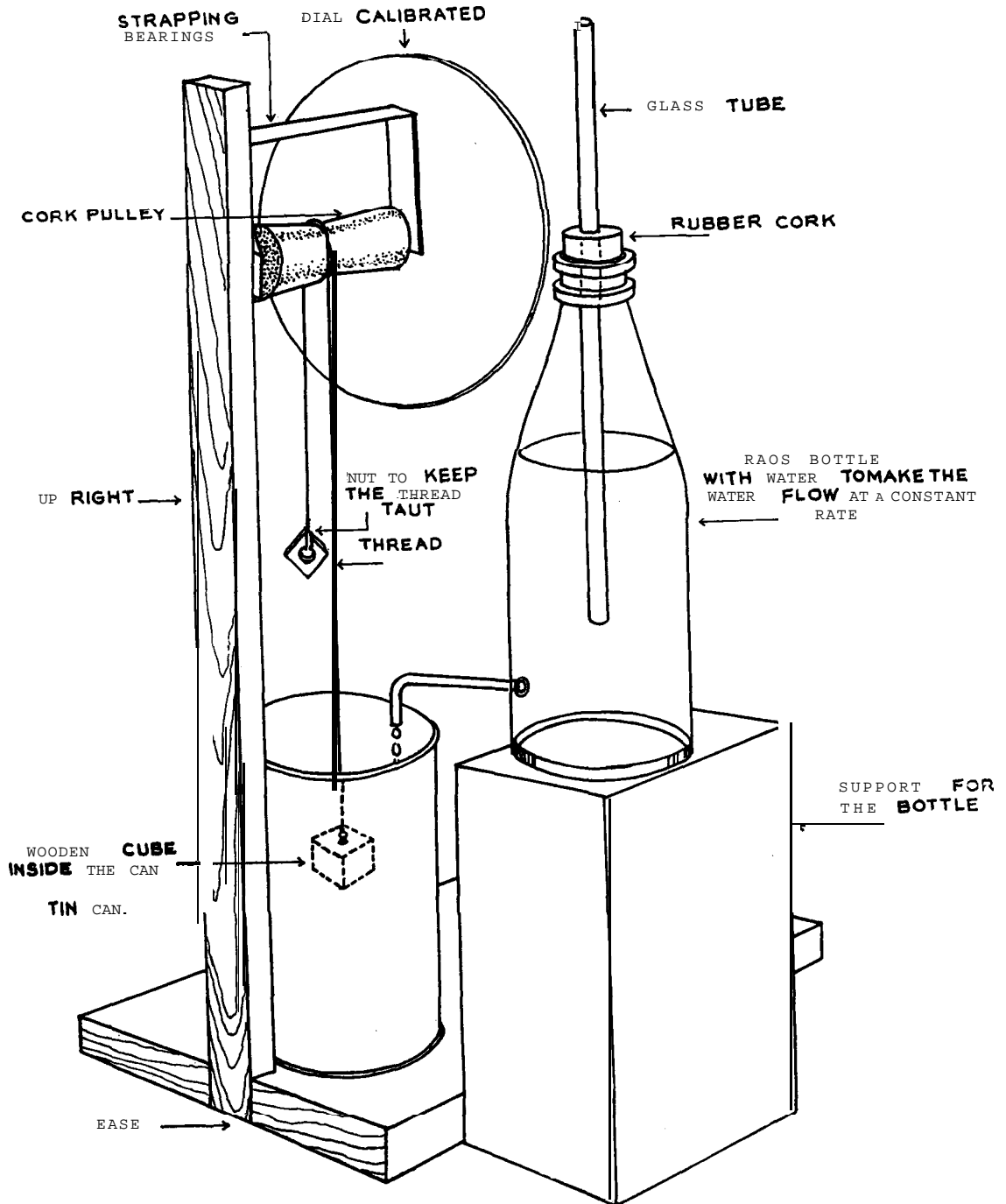

that the water from the bottle flows into the tin can.

8. Make a hole in the circular white cardboard and attach it to the strapping

9. Put a broomstick (a **little** less than the radius of the disk) in the eye of the knitting needle.

10. Mark the position of the **broom** stick as zero.

11. Release water from the bottle and measure the time for the pointer to make a complete circle. Divide the circle into equal parts. For example if the pointer takes 120 seconds to come to the zero mark again, then divide the disk into **120** equal divisions. Each division represents **1** second.

Uses in **practicals** and demonstrations

1. To measure accurately small intervals of time.
2. For use in simple pendulum experiments where a stop watch is needed and not available.

# CURRENT REVERSER

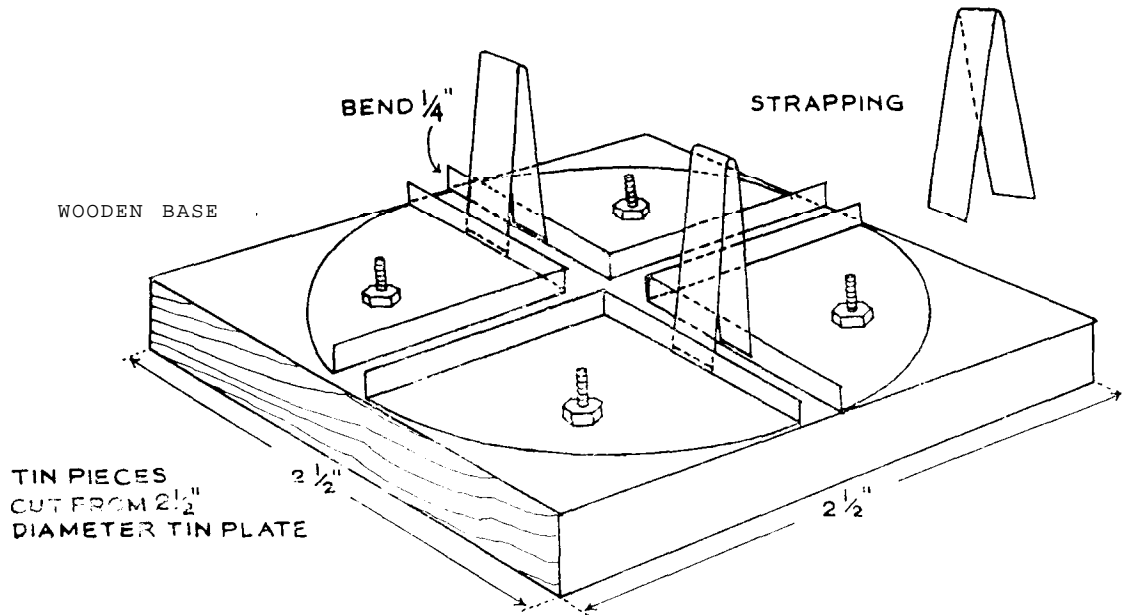

# SWITCH

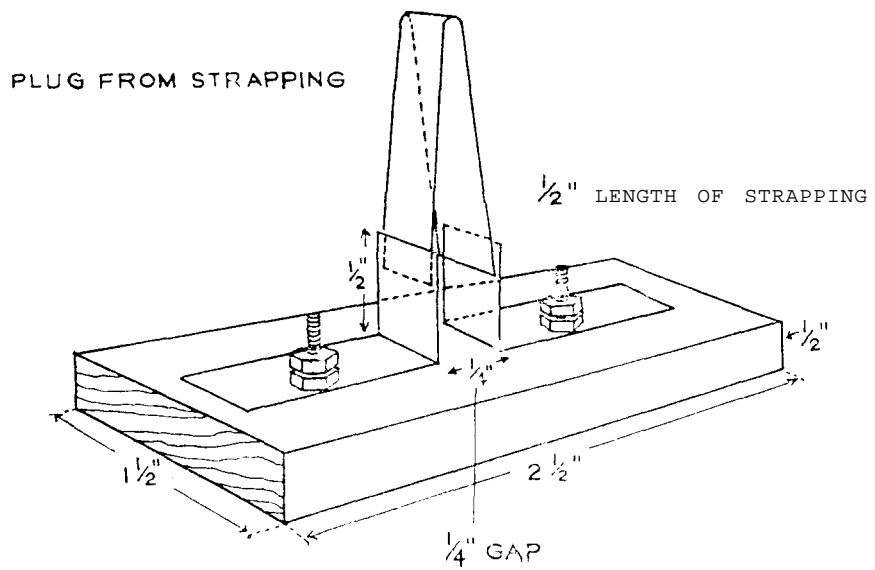

## CURRENT REVERSE

### Materials required for construction

1.  $1/2''$  x  $2\frac{1}{2}''$  wood base.
2. One circular tin piece of  $2\frac{1}{2}''$  diameter.
3. Four bolts and eight nuts.
4. 6'' of strapping.

### Procedure for construction

1. Cut, sand and varnish the wood base
2. Cut the circular tin piece into four sectors of equal size. This can be done by drawing two diameters at right angles to each other and cutting along them. cut out  $1/5''$  squares from the corners of the sectors. Bend the sides upwards (see diagram).
3. Arrange these pieces on the wood base with  $1/4''$  gap between any two of them.
4. Mark the locations for fixing the bolts. Drill the holes in the tin pieces as well as in the wood block.
5. Bolt the tin pieces to the wood base.
6. Cut 3'' pieces of strapping and bend each of them to a "V" shape.
7. Sand the surfaces of contact and assemble as shown.

## PLUG TYPE SWITCH

### Materials required for construction

1. 8'' strapping.
2. Two bolts with four washers and four nuts.
3.  $1/2''$  x  $1\frac{1}{2}''$  x  $2\frac{1}{2}''$  wood base.

### Procedure for construction

1. Cut, sand and varnish the wood base.
2. Take two 2" pieces of strapping bend  $1/2$ " part of each at right angles.
3. Drill two holes in the wooden base  $1\frac{3}{4}$ " apart.
4. Insert the bolts. Drill holes in the longer arm of the strapping  $3/4$ " away from the end. Bolt the strapping pieces to the base. The gap between the perpendicular ends of the strapping should be  $1/4$ ". Fix the washers and the other nuts to each of the bolts.
5. The remaining 4" length of strapping is bent in a "V" shape.
6. Sand the contacting surfaces until the metal shines.
7. Place the "V" shaped piece in the gap between the base's strapping pieces.

## L I N E A R   E X P A N S I O N   A P P A R A T U S

### Materials required for construction

1.  $1/2$ " x 4" x 48" wood upright.
2.  $1/2$ " x 4" x 6" wood base.
3. Two small glass tubes bent at right angles.
4. Iron rod about 1 meter long and 0.2" thick.
5. One worn-out tube light.
6. Broomstick.
7. One pin.
8. A small tin piece.
9. Meter scale,
10. Two corks.

### Procedure for construction

1. Cut and sand the base upright and nail them together. Apply two coats of varnish.
2. Open both ends of the tube light, breaking the bakelite and breaking the glass seals.
3. Make two holes in each cork, one in the centre for the rod and the other for the glass tubing.
4. Close both ends of the tube light with the corks. Push the rod through the centre holes of the corks so that it is along the centre axis of the tube and protruding out of the corks at both ends.
5. Put the glass tubes in the other holes.
6. Place the tube light against the upright and secure in place with either strapping brackets or tape.
7. Put the broomstick on top of the rod approximately 2" from its end. Keep the broomstick in place and at



# LINEAR EXPANSION APPARATUS

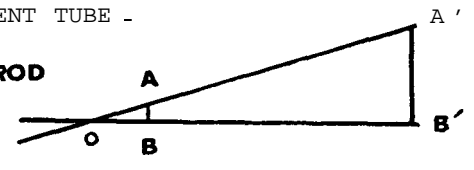
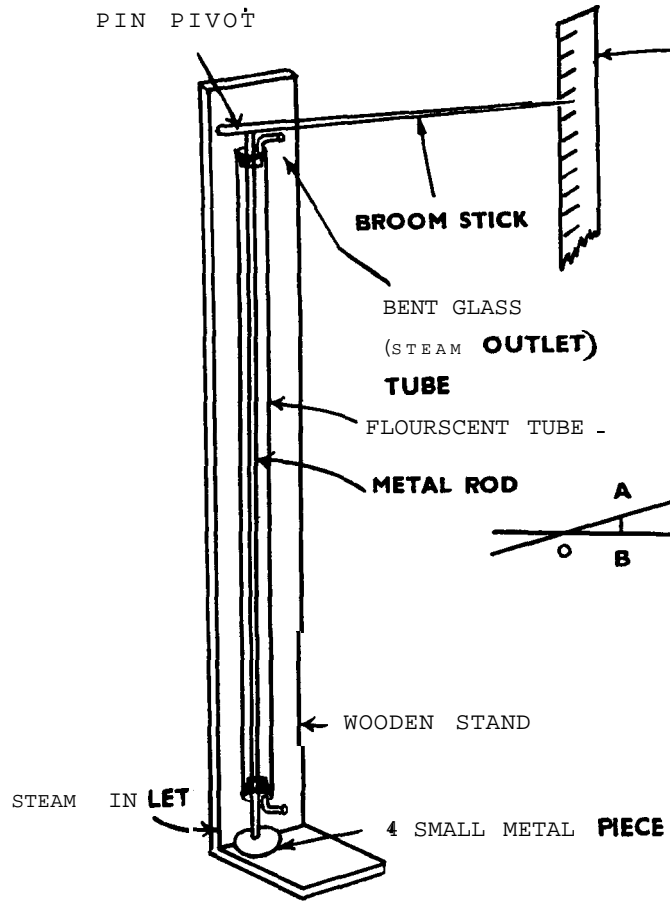

FIG. 2

**OBB'**-LENGTH OF BROOM STICK FROM THE PIVOT, 0  
**B'**= INITIAL POSITION  
**A'**= FINAL POSITION  
**AB**= REAL EXPANSION  
**A'B'**= MAGNIFIED EXPANSION

FIG 1

$$\alpha = \frac{OB \cdot A B'}{OB' \cdot XL (T_2 - T_1)}$$

the same time provide its pivot by sticking a pin through the broomstick and into the wooden upright.

8. The meter scale is fixed vertically to a stand and is placed just behind the other end of the broomstick.

### Questions for further study

1. Investigate the coefficient of linear expansion using rods of various metals.
2. How would you change the apparatus to find the coefficient of linear expansion of a wire ?

# HEATING SOURCE

## BLUE FLAME KEROSENE BURNER

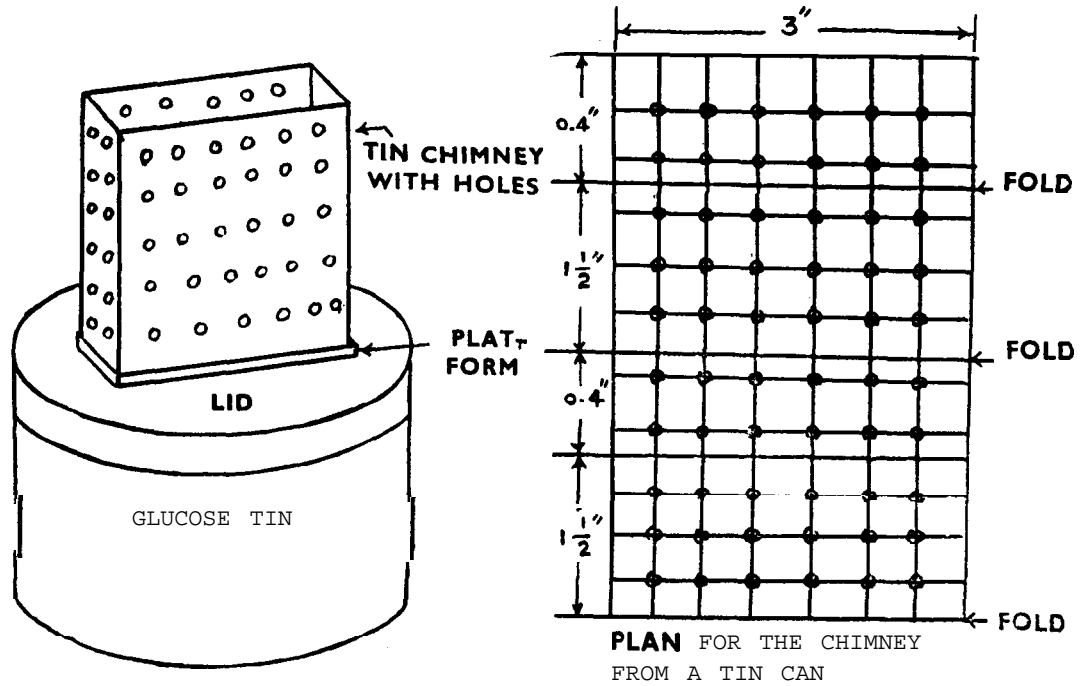

WE CAN GET **CYLINDRICAL CHIMNEY WITH HOLES,**  
 FROM THE JANATA STOVE THIS CAN BE CONVERTED  
 INTO THERECTANGULAR ONE

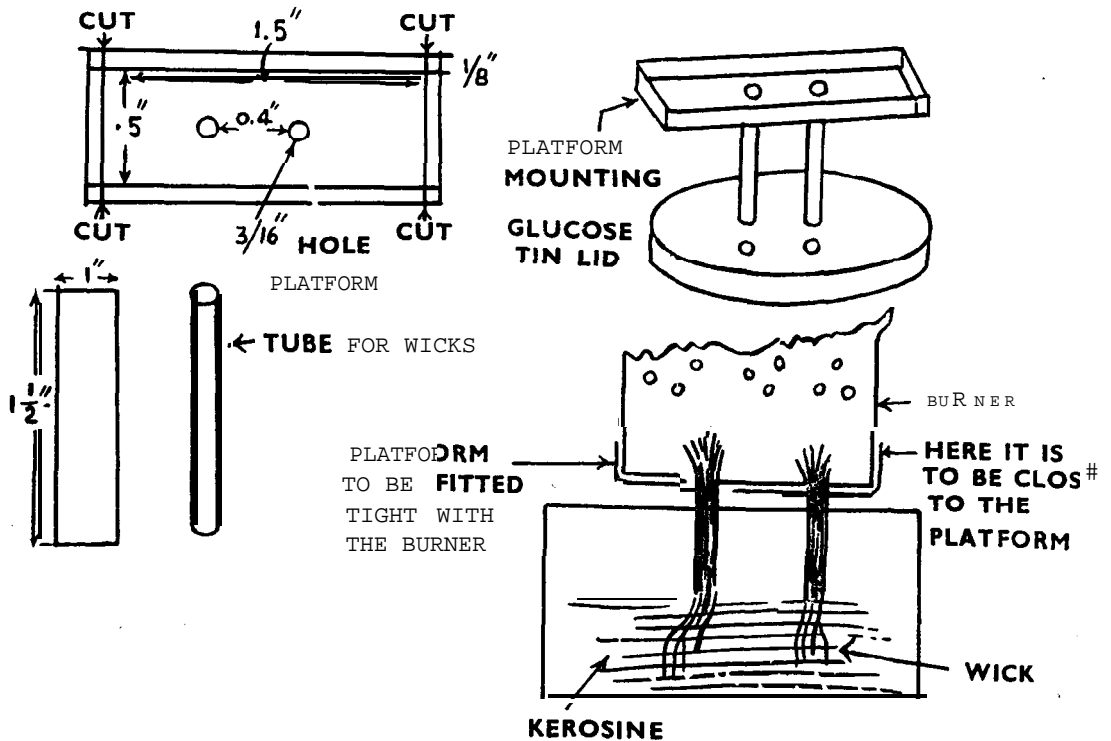

### Materials required for construction

1. One glucose tin with lid 3" diameter and  $2\frac{1}{2}$ " high
2. One 3" x 4" piece of tin.
3. One 1.7" x 0.7" piece of tin.
4. Two 0.5" x 1.5" pieces of tin.

### Procedure for construction

1. The chimney. Mark the tin piece ( see 2 above ) into five parts—0.4"—1.5"—0.4"—1.5"—0.2" as shown in the diagram.
2. Divide the surface of the tin piece into a squares of 0.3". With a sharp  $1/2$ " nail punch holes at the intersection of the lines Then fold the tin piece into a cuboid of 1.5" x 0.4" x 3". The extra 0.2" part serves as a fold to hold the other free edge in position.
3. Platform for the chimney. Take the tin piece mentioned in 3 above, and mark a 1.5" x 0.5" rectangle on it. Cut off the corner squares and fold the edges to form a box. Punch two holes 0.4" apart at bottom of the box.
4. Wick holders : Take tin pieces mentioned in 4 above and role them into tubes of 1.5" length.
5. Punch two holes in the lid of the glucose tin which are 0.4" apart. Align the holes of the platform with that of the lid and push the two wick holders through the holes (both the lid and platform). The holders should be just above the lid of the glucose can.
6. Prepare wicks from cotton thread and push them into the holders.
7. Fix the chimney to the platform.
8. A tin jacket around the chimney may be made to protect the flame from wind currents.
9. If the burner is working properly, there should be a smokeless blue flame hot enough to bend glass easily.

### Uses in practicals and demonstrations

This piece of apparatus can be used as a cheap replacement for your spirit lamps. The cost of running it is much

less and the heat produced is significantly greater.

### Notes on use and construction

It is important that you punch the holes exactly as indicated in the instructions. This is very crucial to its operation. If a blue flame doesn't come, check your work against the instructions very care-

fully and make the necessary corrections. The jacket with holes can also be made from the cylindrical jacket of an old Janata stove.

## GAS TANK FOR BUNSEN BURNER

### Materials required for construction

1. Two  $3/4" \times 3/4" \times 9"$  wood frame pieces.
2. Two  $3/4" \times 3/4" \times 7\frac{1}{2}"$  wood frame pieces.
3. Two  $3/4" \times 3/4" \times 6\frac{1}{4}"$  wood pieces.
4. Four  $3/4" \times 3/4" \times 26"$  wood uprights.
5. One "Deccan Sweet" tin,
6. One kerosene tin  $12\frac{1}{2}" \times 6\frac{1}{2}" \times 6\frac{1}{4}"$
7. Two turpentine tins 3 litre capacity.
8. Sixteen pieces of 14 gauge wire each  $3\frac{1}{4}"$  long.
9. 177" of polyethylene tubing  $1/4"$  exterior diameter.
10. Two two-holed stoppers.
11. 32" of glass tubing.

## Procedure for construction

1. Remove the tops of the two larger tins and smooth the sharp edges.
2. **Make** the square base frame from the two  $3/4" \times 3/4" \times 9"$  pieces and the two  $3/4" \times 3/4" \times 7\frac{1}{2}"$  pieces as shown in the diagram.
3. Drill eight small holes in a straight line halfway through the four  $3/4" \times 3/4" \times 26"$  uprights starting 4" from one end and keeping a 2" space between each **hole**.
4. Bend the 14 gauge wire pieces in the shape shown in the diagram and fix them in each pair of holes starting from one end. Be sure that they do not protrude more than  $1/2"$  from the uprights as shown in the diagram.
5. Nail the four uprights to the wooden base in the position shown.
6. Fit the whole frame inside the kerosene tin. Bolt the uprights to the top of the tin making sure that they are perpendicular to the base.
7. Drill two  $1/4"$  holes on opposite sides of the "Deccan Sweet" tin 1" from the top.
8. Drill a  $1/4"$  hole into the middle of the  $6\frac{1}{4}"$  piece of wood.
9. Take two pieces of polyethylene tubing 45" in length and put them through the holes in the "Deccan Sweet" tin. Then put the tubing through the holes in the  $6\frac{1}{4}"$  pieces of wood. Wedge one of these pieces 1" from the bottom of the "Deccan Sweet" tin and the other 1" from the top.
10. Attach the tubing that is in the piece of wood 1" from the top of the tin to a pump and the other to the first turpentine tin (gasoline tank) as shown in the diagram. Invert the "Deccan Sweet" tin and place inside the kerosene tin.
11. The gasoline tank should have a two-holed stopper. One long glass tube reaching to the bottom of this tank is inserted through this stopper. Another short glass tube is inserted so that it penetrates the can to a depth of only 1". The polyethylene tubing from the "Deccan Sweet" tin should be connected to the long glass tube in the gasoline tank.
12. The second turpentine can, the safety tank, should also have a two holed stopper with the same type of glass tubing in it. A 17" piece of polyethylene tubing is connected from the short tube in the gasoline tank to the long glass tube in the safety tank.
13. Polyethylene tubing, 70" in length, is connected from the short tube of the safety tank to the **bunsen** burner.
14. Fill the kerosene tin with water to  $4/5$ ths of its capacity. Place a 3 litre tin full of water on top of the "Deccan Sweet" tin to serve as a weight.
15. Fill the gasoline tank with a maximum of two litres of petrol.
16. The safety tank should be filled with water to  $4/5$ ths of its capacity. This tank is a safety measure to prevent any back-fire from the **bunsen** burner.

PARTS FOR GAS TANK AND  
BUNSEN BURNER

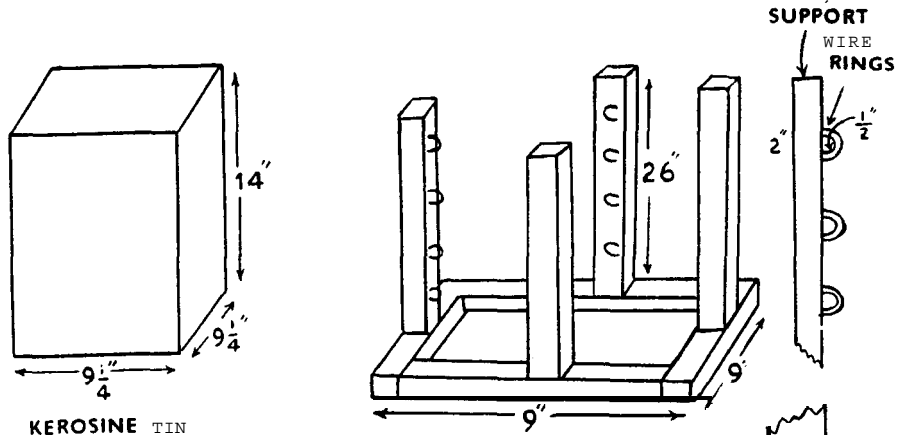

KEROSINE TIN

WOODEN SUPPORT FOR AIR  
RESERVOIR

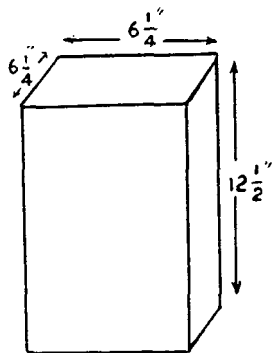

OIL TIN

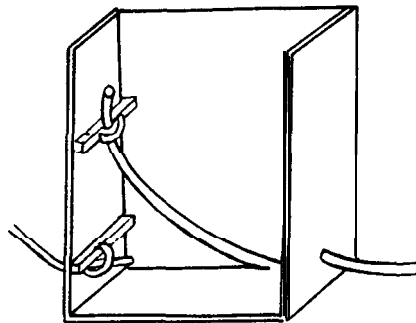

OIL TIN  
INSIDE VIEW

14 GAUGE WIRE

TIN TO CONTROL  
FLOW OF AIR

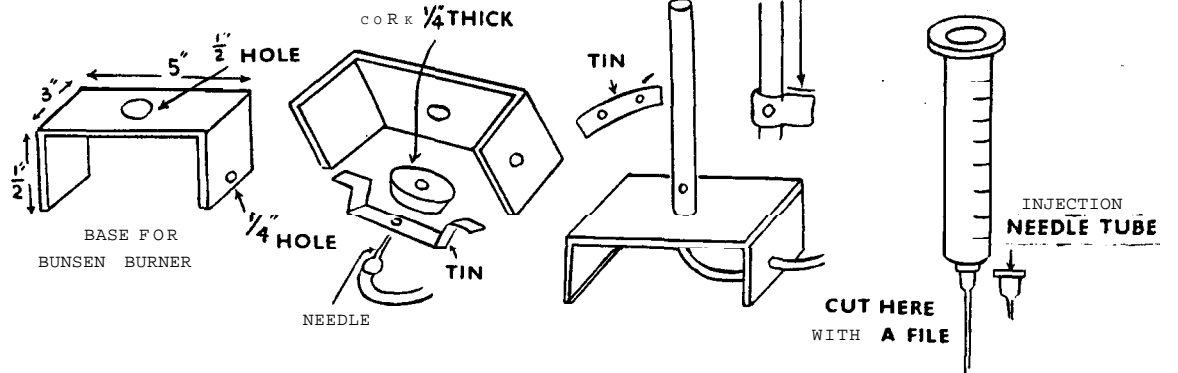

17. Pump air into the “Deccan Sweet” tin to its capacity.

18. Check to make sure that there are no leaks in the connections and then light your Bunsen burner.

### Uses in **practicals and demonstrations**

To provide an inexpensive and efficient heat source for student use.

### **Notes on use and construction**

The Bunsen burner and the gas plant have the capacity of working for fifteen minutes with one pumping.

If injection needles are hard to find, then a ball point pen cartridge may be used. Simply use a small file and remove the ball from the point. But try to keep the hole small and if neces-

sary place a piece of 32 gauge wire in the hole to slow down the flow of gas. Cut the cartridge to about 1” length and fit tightly in the copper tubing.

Another alternative to the injection needle would be to use a jet tube made from glass tubing.

### **Notes on how it works**

By forcing air through the fuel tank, petrol is vaporized, passed through a safety tank and finally to the Bunsen burner. The safety tank serves as a device to stop any back-fire through the polyethylene tubing before

it reaches the fuel tank. This **precaution** must be observed. Before **operating**, check and make sure that the tubing coming from the fuel tank is well beneath the surface of the water in the safety tank.

# GAS TANK AND BUNSEN BURNER

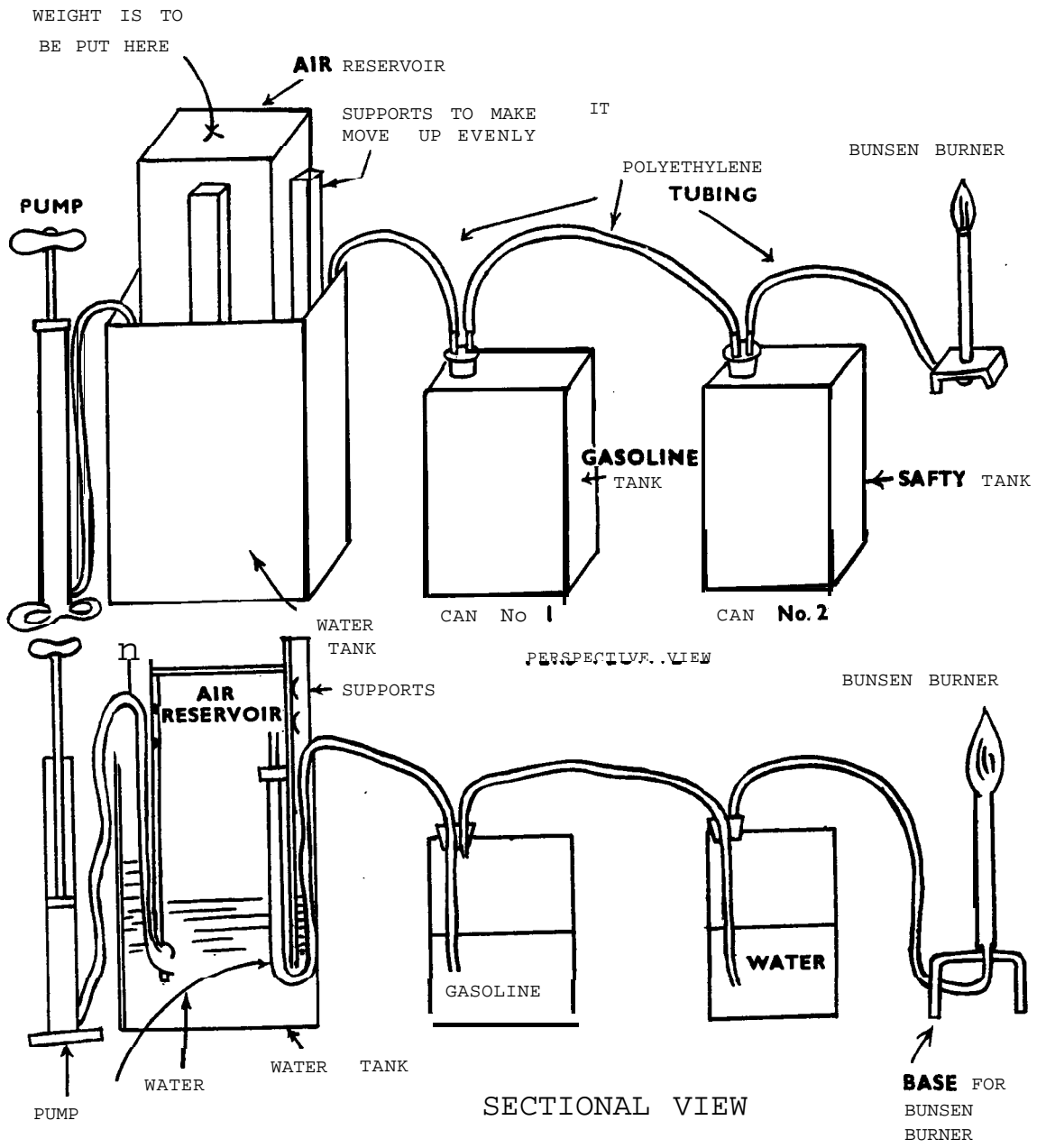



# BUNSEN BURNER

## Materials required for construction

1.  $5\frac{1}{2}$ " of copper tubing  $5/16$ " in diameter.
2. Injection needle.
3.  $3/4$ " x 3" x 5" wood piece,
4. Two  $3/4$ " x 3" x  $2\frac{1}{2}$ " wood pieces.

## Procedure for construction

1. Drill a  $1/2$ " diameter hole in the centre of the  $3/4$ " x 3" x 5" wood piece.
2. In one of the pieces mentioned in (2) above, drill a  $1/4$ " hole  $1/2$ " from the end at the middle of its 3" width as shown in the diagram.
3. Drill a  $3/16$ " hole completely through the copper tubing 1" from one end.
4. Make a stand for the burner by attaching the  $3/4$ " x 3" x  $2\frac{1}{2}$ " pieces to the base piece as shown in the diagram.
5. Cut the cork to  $1/4$ " thickness and drill a  $1/4$ " hole in the centre.
6. Drill a  $1/4$ " hole in the centre of a piece of strapping.
7. Attach the copper tubing to the  $1/4$ " hole in the base making sure that  $3/16$ " holes are just above the wood.
8. Break the end of an injection needle by cutting it with a small file. Insert the butt of the needle into the polyethylene tubing (from the safety tank) ; then put it in through the (1) strapping and the (2) cork. Pass the tubing through the hole in the platform and up into the copper tubing.
9. Nail the strapping and cork to the bottom of the platform. See diagram.
10. Have the tip of the needle come just up to the middle or bottom of the  $3/16$ " holes in the copper tubing.
11. Cut two  $3/16$ " holes in a piece of tin  $1\frac{1}{2}$ " long and  $5/16$ " wide such that they will be concentric with the holes in the copper tubing. Wrap the tin around the copper tube so that it fits fairly tightly. The air intake of the burner can be regulated by rotating this piece.
12. Take 10" of 32 gauge wire and roll it into a ball about  $1/2$ " in diameter. Put the ball half way down the copper tube. This helps to make an even flame for your burner.

# TELEGRAPH

3 DIMENSIONAL VIEW

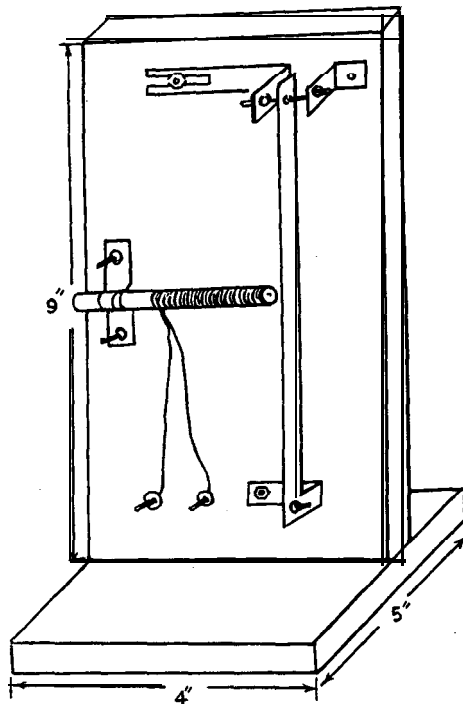

FLAT VIEW OF UPRIGHT FACE

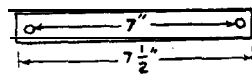
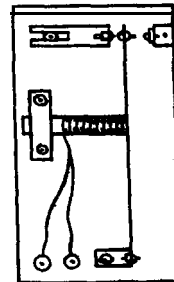

B  $\frac{3}{16}$ "  $\frac{1}{4}$ "  $\frac{3}{16}$ " HOLE :

BEND HERE

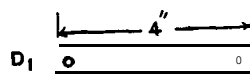

STRAIGHT PIECE WITH HOLES

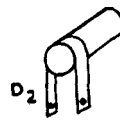

BEND ABOUT ROD LIKE THIS

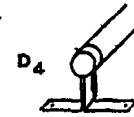
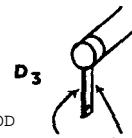

PINCH HERE WITH PLIERS TO GET STRAPPING COMPLETELY AND TIGHTLY ABOUT THE ROD

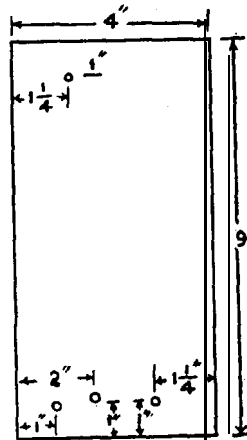

NAIL HOLE  $\frac{3}{16}$ " DRILL HOLE



BEND HERE ( $\frac{3}{4}$ " FROM DRILL HOLE)



DRILL  $\frac{3}{16}$ " HOLES HERE

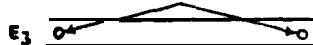

BEND HERE

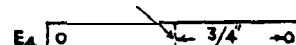

## TELEGRAPH

### Materials required for construction,

1. 1" x 4" 9" wood piece.
2. 1" x 4" x 5" wood piece.
3. 3 metres of 24 gauge enamelled copper wire.
4. One soft iron rod 1 cm diameter and 2½" in length.
5. Metal strapping.
6. Ten 3/16" bolts with nuts.

### Procedure for construction

1. Cut and sand the wood pieces given in 1 and 2 above.
2. Drill 3/16" holes in the upright as shown in the diagram.
3. Nail the upright to the centre of the base and varnish the pieces.
4. Cut five pieces of metal strapping to these exact lengths : one piece 7½", one piece 2½", two pieces 1¾" and one piece 4½".
5. In the 7½" piece, drill two 3/16" holes which are exactly 7" apart from centre to centre.
6. Drill a 3/16" hole in one end of the 2½" piece of strapping. At the other end cut a notch along the longitudinal axis of the strapping 1¼" long and 3/16" wide. At a point exactly 1¾" from the centre of the hole, bend the strapping up 90°.
7. Drill a 3/16" hole in each end of the 4½" piece of strapping. Bend this piece of strapping around the iron rod which you will use for the core of the electromagnet and pinch the strapping at the point where the bends meet. Thus the strapping should conform exactly to the shape of the rod and the ends of the strapping should meet and be pressed together with the end holes lined up. Bend the feet on this piece such that the center of the iron rod will be 3/4" above the upright.
8. Drill a 3/16" hole near either end of one of the 1¾" pieces. Make a nail hole 1/2" from the other end. Bend the piece making a 90° angle 3/4" from the center of the 3/16" hole.
9. In the other 1¾" piece, drill a 3/16" hole in each end. Make the 90° angle 3/4" from one of these holes.
10. Place the 4½" strapping piece holding the iron rod at the left hand side of the upright as shown in the drawing. Bolt the piece to the upright.
11. Fasten the 2½" piece in the hole at the upper left hand part of the upright as shown in the diagram. When the bolt is loose, the strapping should slide freely along the slot.
12. Nail 1¾" piece (the one with the nail hole) at the upper right hand corner of the upright. See diagram. This piece should be on a straight line with the piece on the top life. This piece is used for providing a rest for the moving piece of the telegraph.
13. Bolt the other 1¾" piece to the hole on the right bottom side of the upright. Bolt the shorter arm of this piece.

**14.** With a  $\frac{3}{8}$ " long  $\frac{3}{16}$ " bolt, fasten the  $7\frac{1}{2}$ " piece of strapping as shown in the diagram. Put a  $\frac{1}{4}$ " to  $\frac{3}{8}$ " long  $\frac{3}{16}$ " bolt through the hole at the other end and fasten with a nut. This will serve as the "hammer" of the moving piece.

**15.** Leaving about 5" free, wind all the copper wire around the iron rod neatly. Note : Leave about 1" of one

end of the rod free from the windings so that this end may be used in the metal strapping holder.

**16.** Remove the enamel insulation from the ends of the wire and attach them to the contact bolts at the bottom of the upright.

**17.** Connect one or at most two cells to the terminals and with a little adjusting your telegraph should work.

#### Uses in **practicals** and demonstrations

This piece of apparatus is useful in teaching an application of electromagnetism.

#### Notes on use and construction

It is most important that when constructing this piece of apparatus that the plans be followed precisely. Adjustment of the distance between the **move-**

able arm and the electromagnet will be necessary after you have completed **assembling** this piece. This may take some **time** and patience.

### A D J U S T A B L E      R I N G      S T A N D

#### Materials required for construction

1.  $\frac{1}{2}$ " x  $\frac{1}{2}$ " x 12" (or  $\frac{1}{2}$ " diameter dowel) wooden upright.
2.  $\frac{1}{2}$ " x 4" x 6" wood base.
3. 19" of strapping.
4. 2" of stiff wire.

#### Procedure for construction

1. Cut and sand the upright and base.
2. Cut a notch on the 4" side with the saw and chisel. The notch should conform to the dimensions of the upright and be located in the centre of one end. Nail the upright in this notch and varnish this assembly with two coats of **varnish**.
3. Bend the strapping so that a  $2\frac{1}{2}$ " to 3" diameter ring is formed in the middle.
4. Take two  $1\frac{1}{4}$ " pieces of strapping and bend them around the strapping arm between the ring and the upright.

# HEATING STAND OR FUNNEL STAND

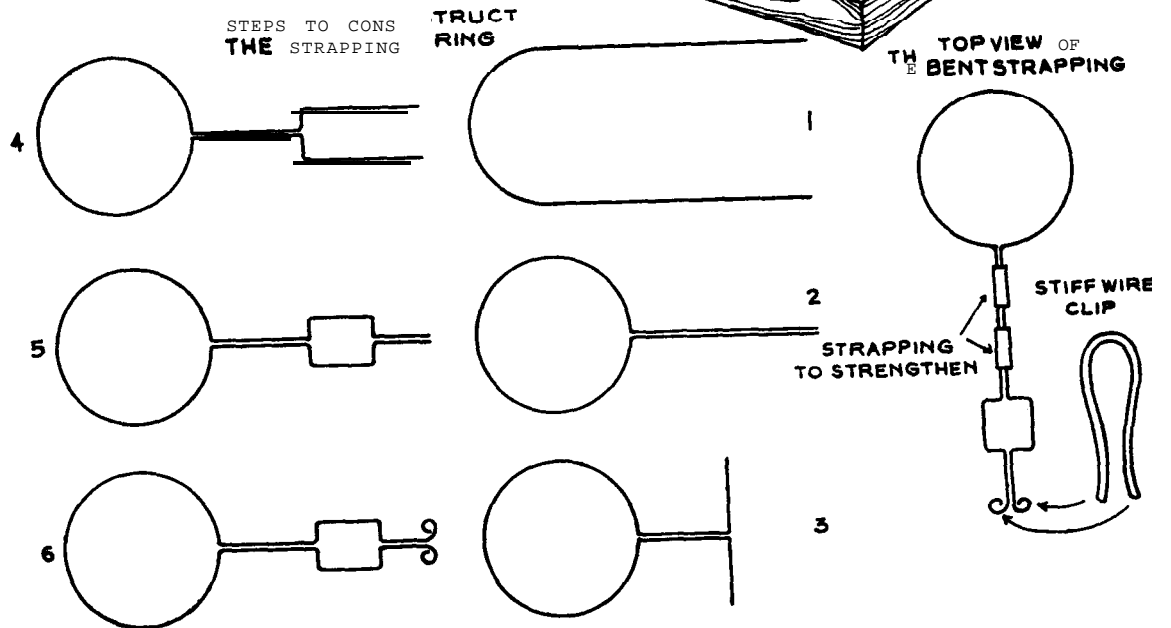
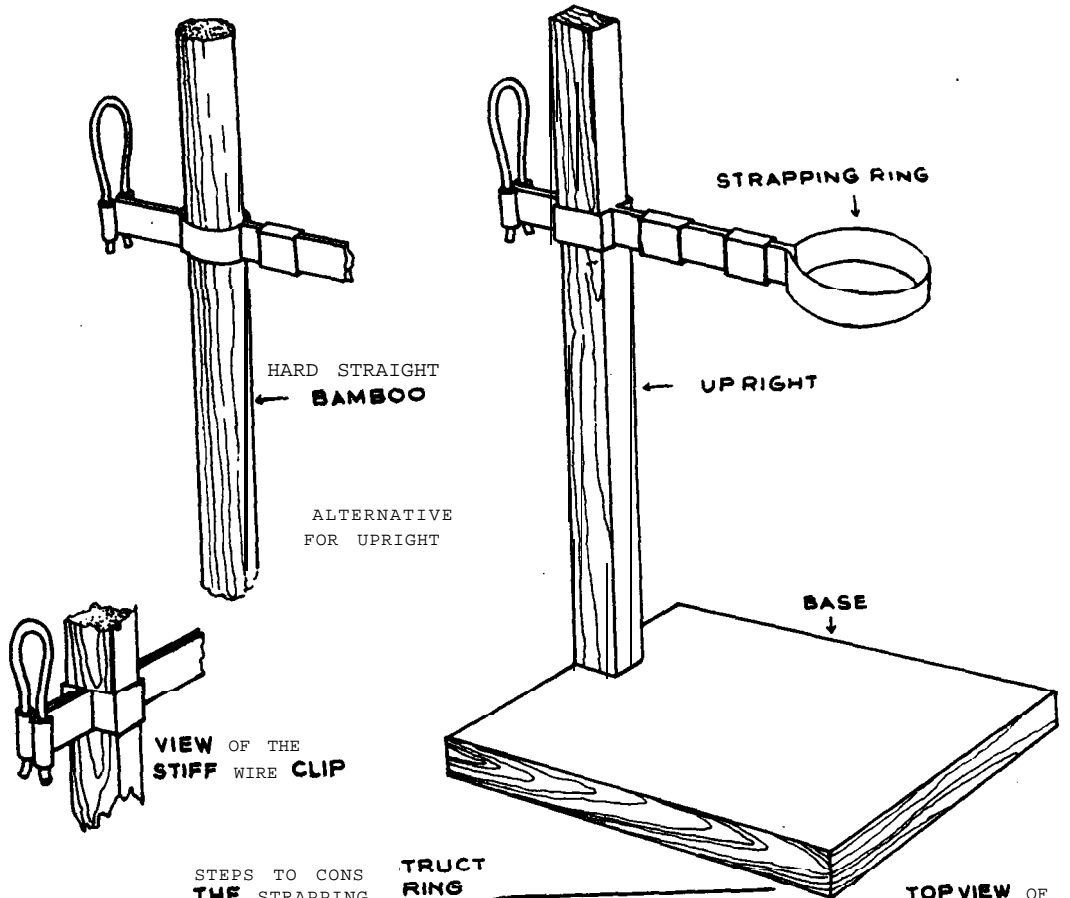

5. **2"** from the ring, bend the arms of the ring to form a square which will conform to the shape of the upright. See diagram.

6. Bend the ends of the strapping forming two cylindrical loops as shown in the diagram.

7. Bend the stiff wire into a "U" shape with the ends of the "U" being fairly close to each other.

8. Fix the ring to the upright and insert "U" shaped holder into the ends. The pressure exerted should be enough to fix in place.

## LIGHT BULB TEST TUBE OR FLASK

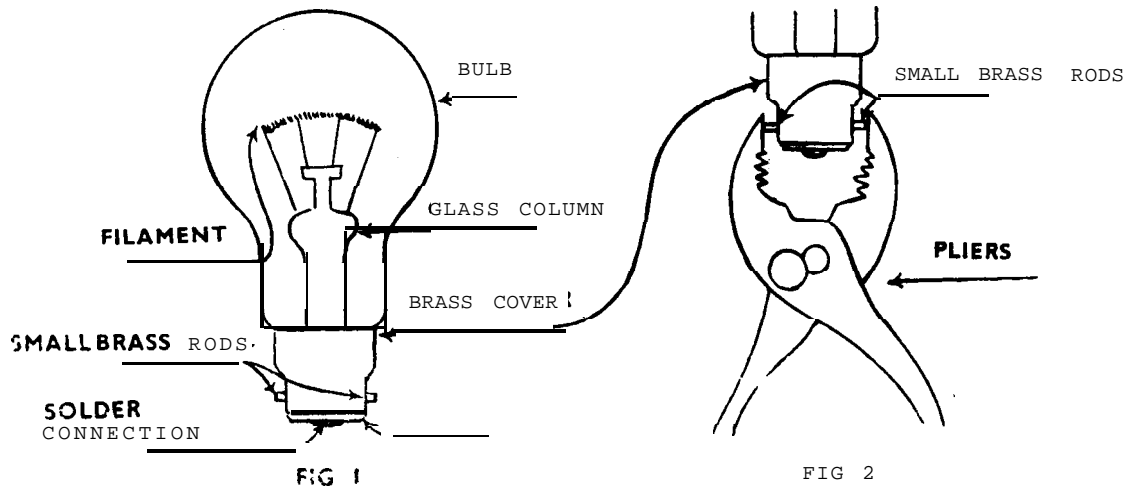

## LIGHT BULB TEST TUBE OR FLASK

### Materials required for construction

1. Burned out light bulbs.
2. Sharp pointed instrument.

### Procedure for construction

#### *Caution*

Hold **the** light bulb with a cloth **at** all stages. Wearing glasses is also recommended

#### *Note*

Empty light bulbs can be used as **test** tubes and flasks. They are made of **pyrex** glass and can withstand high temperatures.

1. Remove **the** two soldered connections at the base of the bulb by wedging under them **with** a pointed instrument. Lift them off, breaking the wires.

2. Next, break up the ceramic base by placing the pointed instrument in **the** wire holes uncovered in step 1, and twisting the instrument **until** the ceramic breaks up and falls **out**. This may **take** some patience.

3. Another way **to** initially crack the ceramic is to grip the small brass rods on the side of the brass cover with a pair of pliers and squeeze very hard.

4. When the ceramic base is removed you can see the inside of the hollow glass column which goes into the bulb. This must be broken off. Insert the screwdriver or the sharp end of the triangular file into the column and give it a sharp **tap** on **the** table top; the column will be broken off inside the bulb.

5. Using the screw driver or file, enlarge the hole in the glass enough so that the glass column can be removed. Continue to smooth out and enlarge the hole and remove most of **the** seating material.

6. Clean **the** bulb and it is ready for use.

# WIRE TEST TUBE HOLDER

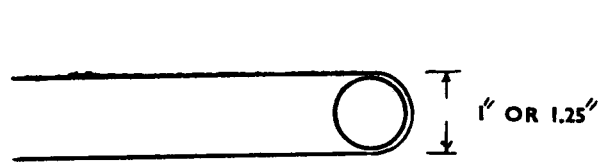

FIG. 1

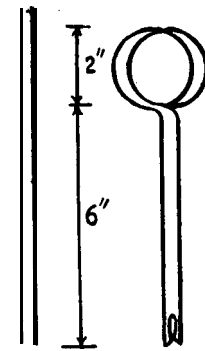

FIG. 1



FIG. 3



FIG. 4



FIG. 5

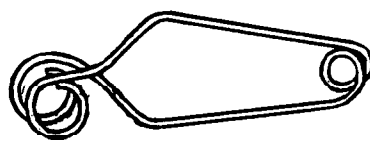

STRAPPING

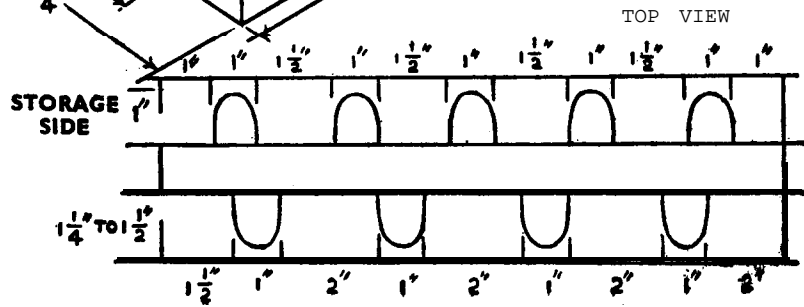
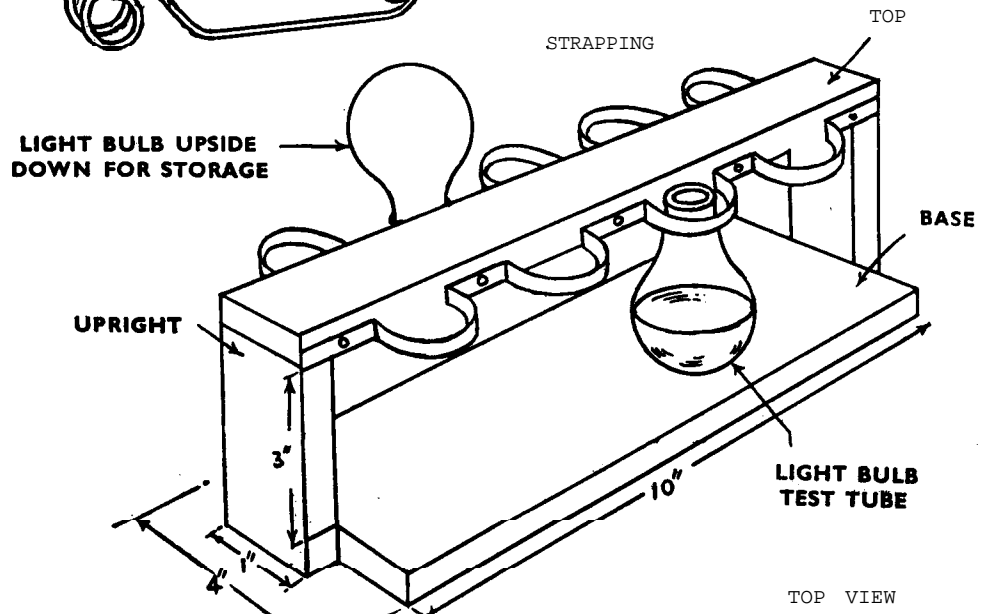



## WIRE HOLDER FOR LIGHT BULB TEST TUBES

### Materials required for construction

2½ to 3' of strong wire.

### Procedure for construction

1. Straighten the piece of wire. Place its ends together, and form a 1" circle at its mid-point. This may be done by wrapping the wire around an object of a suitable diameter.
2. At points about 6" from the circle, bend 2" diameter circles in the wire.
3. Shape the handles until the holder looks like the one in the diagram.

## LIGHT BULB TEST TUBE RACK

### Materials required for construction

1. 1/2" x 4" x 12" wood base.
2. 1/2" x 1" x approximately 13" wood top piece (see note).
3. Two pieces 1/2" x 1" x approximately 3½" uprights.
4. Three feet metal, strapping.

### Procedure for construction

**Note:** For most light bulbs the distance between the base and the top should be exactly 3" as you will notice on the diagram. Therefore, the length of the uprights should be 3" plus the thickness of the bottom piece. As the wood varies somewhat in thickness, it may not be exactly 1/2". Measure the wood and cut the uprights to the proper lengths. The length of the top piece should be adjusted in the same way, its length being the length of the base plus the thickness of the uprights.

1. Cut and sand the wood pieces.
2. Nail the two uprights to the base. Nail the top pieces to the uprights.
3. Varnish the entire piece.
4. Bend the strapping to the shape indicated in the diagram.
5. Be certain that the light bulbs will fit into the loops. Then punch holes in the strapping for attachment to the top piece. The holes may be punched with large 3/4" nails.

# HYDRO METER



FIG. 1



FIG. 2



DIP THIS IN MELTED CANDLE WAX



SECTIONAL VIEW

NAILS TO MAKE  
IT FLOAT IN WATER  
VERTICALLY  
SEALING WAX

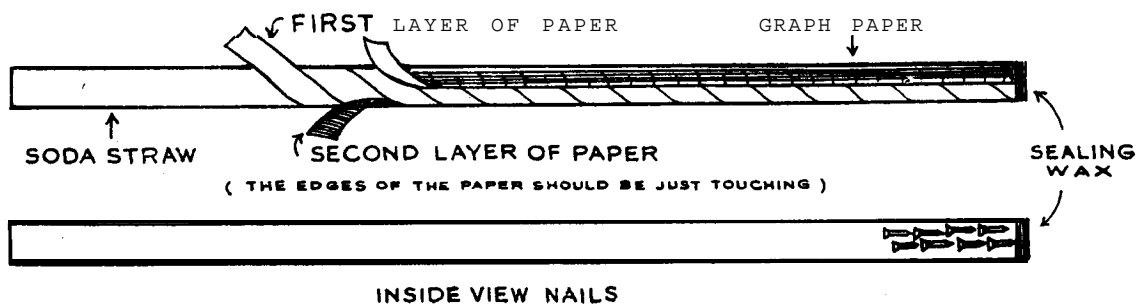

# S I M P L E H Y D R O M E T E R

## Materials required for construction

1. One soda straw.
2. Two pieces of strong wire.
3. Long 1/4" wide paper strips.
4. Candle wax or sealing wax.
5. Varnish.
6. Graph paper.
7. Flour paste.

## Procedure for construction

1. Cut long and uniform 1/4" wide strips from regular white paper. Apply thick flour paste to the strip and wrap it spirally around the straw such that each turn of the paper is adjacent to but not on top of the preceding turn. Cover the straw twice in this manner. A narrow piece of graph paper should be cut and applied at this time. It should be numbered beginning with 0.0 at the bottom,

2. While the paste is drying, insert the wire pieces into one end of the straw and seal that end with wax.

3. When the paste is dry, give the

hydrometer two coats of varnish-

4. Test the hydrometer. If it doesn't stand upright insert additional pieces of wire through the top and then seal with wax.

5. For a hydrometer of this type specific gravity of the liquid is equal to :

$$\frac{\text{scale reading in water}}{\text{scale reading in } g_x}$$

6. The dry stem of a maize plant or a wooden dowel of a uniform diameter can also be used to construct the hydrometer. To make the wood or maize float vertically, weight one of its ends.

## Uses in practicals demonstrations

1. To illustrate the laws of flotation.
2. To determine the specific gravity of liquids.

## Questions **further study**

1. Does the hydrometer displace the same volume of any liquid in which it floats? What is the reason for your answer?
2. How can convert the hydrometer into a lactometer, alcoholmeter or a sulfuric **acid meter** ?
3. Can you use any floating body to measure specific gravity ?
4. Why should **the** hydrometer float vertically only ?
5. **If** the cross section of the hydrometer were a square, rectangle, hexagon or the like, would it be useful for finding the specific gravity of liquids?
6. **Is** the cross sectional area a **relevant** variable when considering the proper functioning of the hydrometer? What are the reasons for your answer?
7. How can you **increase** the sensitivity of **the** hydrometer?

## **TRI-POD** S T A N D

Material **required for** construction

54" of heavy wire

### **Procedure** f o **construction**

1. Cut **the** wire **into** three equal **pieces** of 18".
2. Take two pieces and twist them together for the first 7".
3. Take the third piece and twist it in a similar manner but with the free ends of **the** first two pieces. See diagram.
4. The twisted portions should all be 7" in length.
5. The triangle formed at t h e **cent** should have equal sides of 4" in length.
6. Bend the finished parts at the corners of the triangle to form the legs.
7. The last inch of each leg is to be bent outwards (away from the triangle) to form "feet" for further support.

# TRIPOD STAND

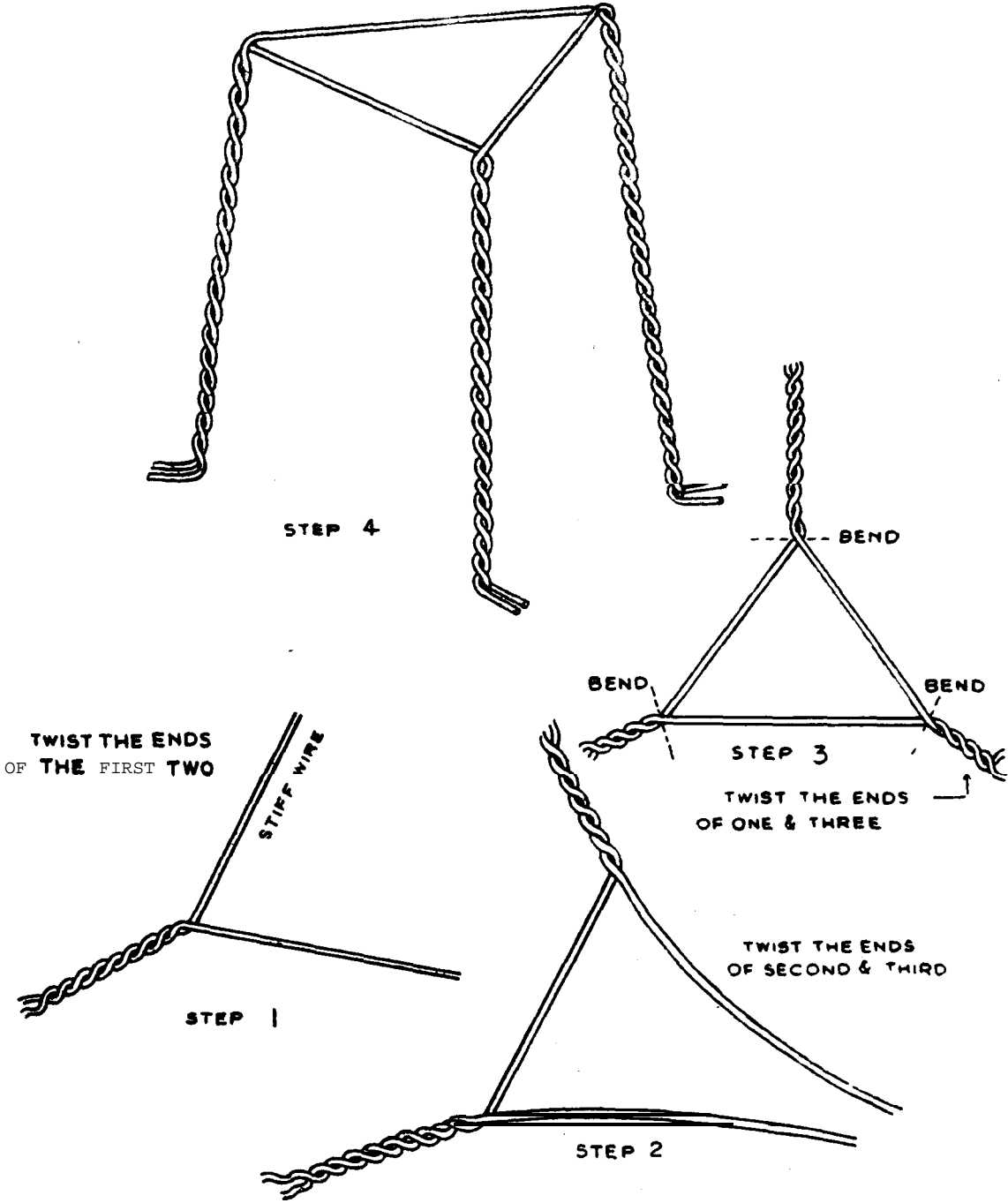

# DESICCATOR

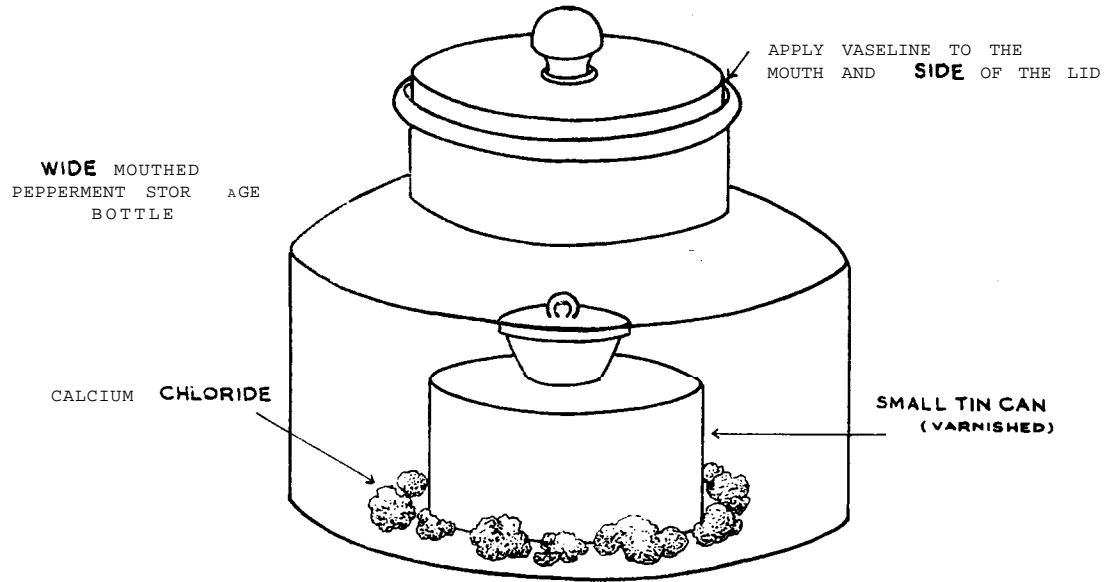

# BEEHIVE SHELF

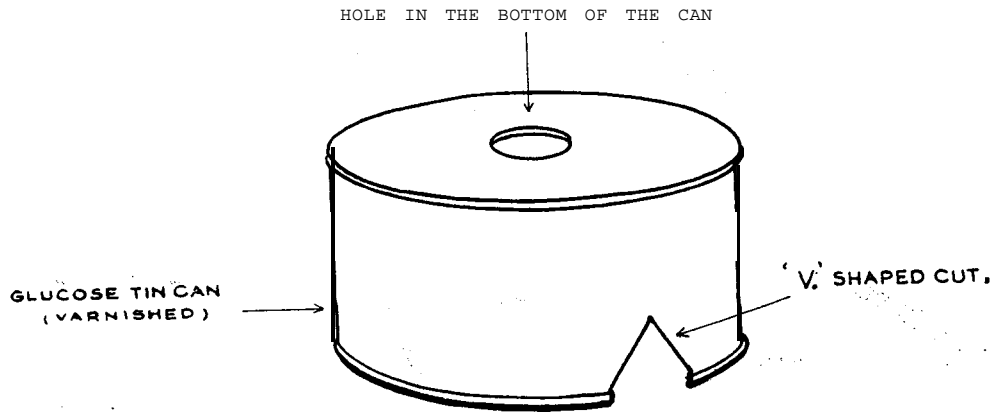

## **D E S S I C A T O R**

### **Materials required for construction**

1. One peppermint bottle of 6" diameter,
2. Four 1" cubes of wood.
- 3, One tin small enough to fit through the mouth of the bottle.

### **Procedure for construction**

1. Apply Vaseline to the mouth and side of the lid of the peppermint bottle.
2. Varnish the small tin.
3. Assemble as shown in the diagram.

## **B E E H I V E S H E L F**

### **Materials required for construction**

One small glucose tin.

### **Procedure for construction**

1. Cut a "V" shaped notch  $1/2$ " high on the side at the top of the can.
2. Invert the can **and** drill a hole  $3/8$ " to  $1/2$ " in diameter in the bottom.
3. Varnish the tin.

# VELOCITY OF SOUND APPARATUS

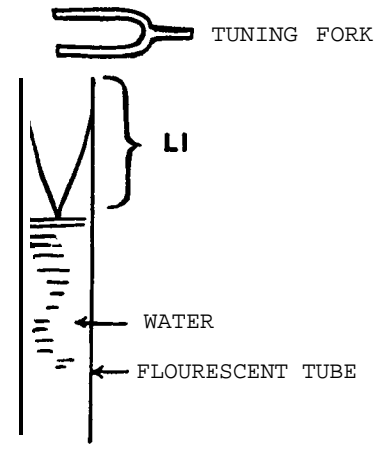
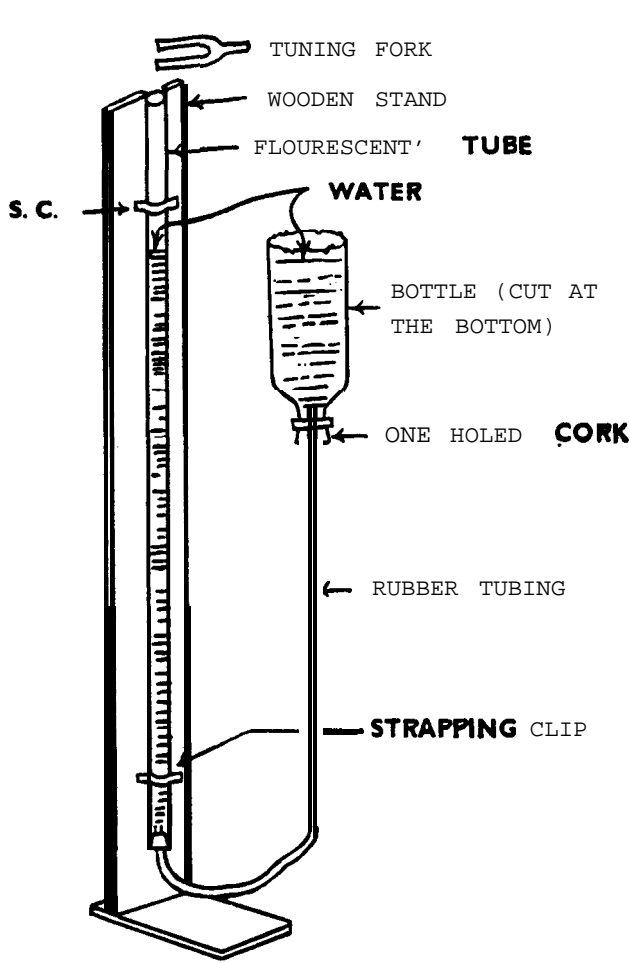

FIG. 1

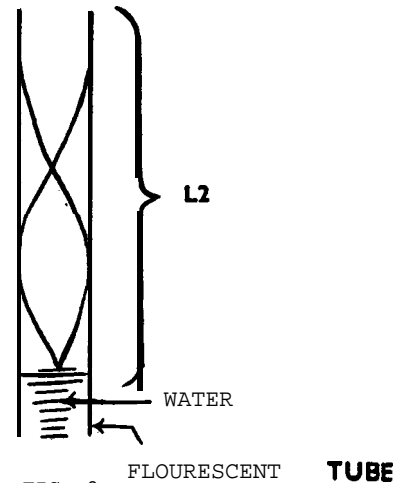

FIG. 2

# VELOCITY OF SOUND APPARATUS

## Materials required for construction

1. One tube light.
2. One 4 pound bottle.
3. Two one-holed rubber stoppers.
4.  $1/2" \times 4" \times 50"$  wooden upright.
5.  $1/2" \times 4" \times 12"$  wooden base.
6. Rubber tubing-
7. Glass tubing.



### Procedure for construction

1. Cut the base and upright to size. Attach them as shown in the diagram. Varnish.
2. Open both ends of the fluorescent tube (tube light) leaving the metal end pieces on, if possible. Wash the tube light by washing with water and a rag.
3. Secure the tube to the upright by using metal strapping brackets as shown in the diagram.
4. Put the one-holed stopper in the bottom of the tube and fix a small glass tube in the hole. Attach the rubber tubing.
5. Cut-off the bottom of the 4 pound bottle (see Chapter VII). Place the other one-holed stopper in its mouth.
6. Insert another glass tube in the bottle's stopper and attach the other end of the rubber tubing.

### Uses in practicals and demonstrations

1. To find the velocity of sound.
2. To find the wavelengths of sound waves.
3. To demonstrate resonance.

### Questions for further study

1. What is the relationship between the wavelengths of two sounds one octave apart ?
2. Does the distance between the tuning fork and the top of the cylinder make any difference in the results ?
3. Does the diameter of the tube affect the results? Does its length?
4. Does the temperature of the medium affect the length of time the sound can be heard ?
5. Does the height of the water column affect the length of time the sound can be heard?
6. Can you use any liquid other than water and obtain the same results ?
7. Can you think of any other way of finding the velocity of sound using the fluorescent tube and without using water any other liquid ?

# U -TUBE MANOMETER

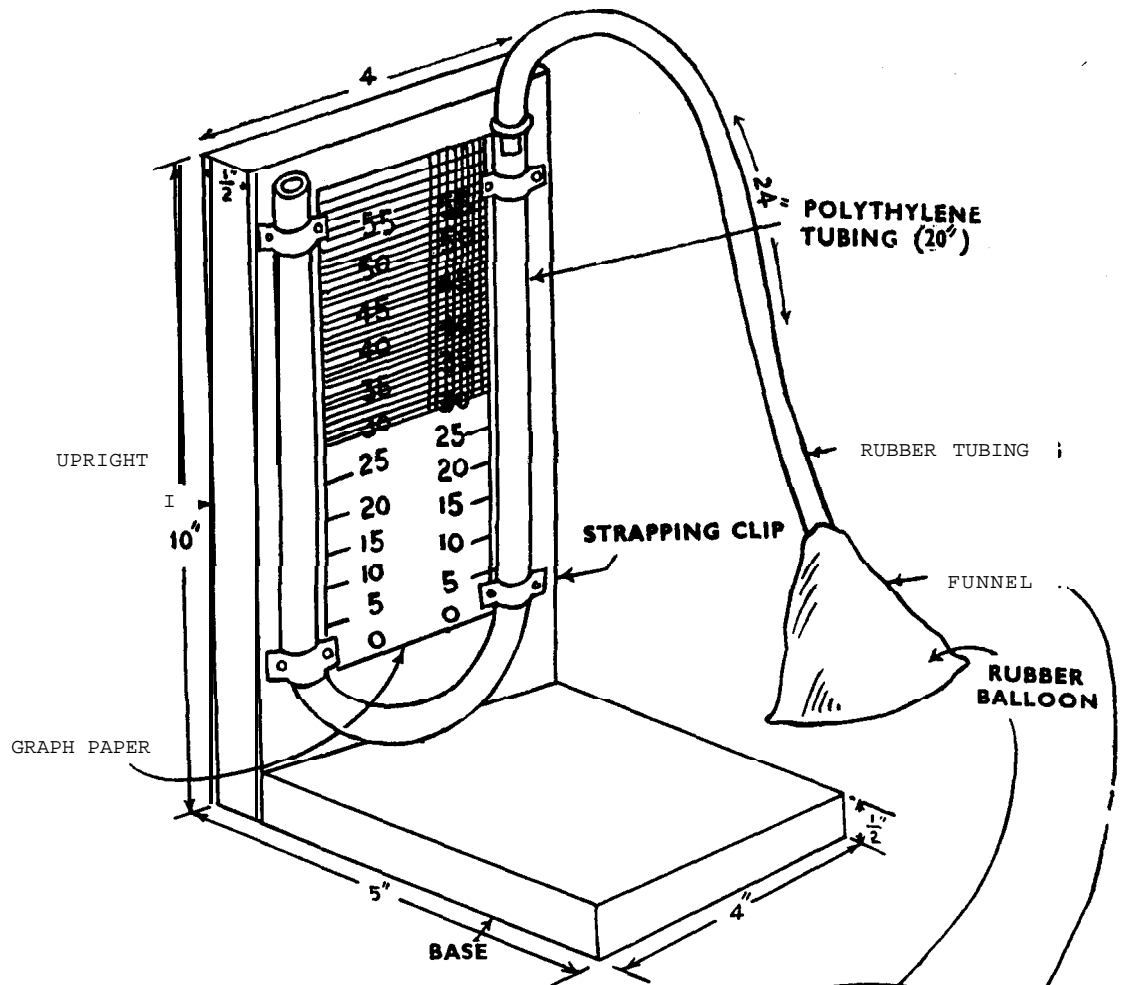

## METAL CLIP

METAL STRAPPING 1.5" LONG



FIG. 1

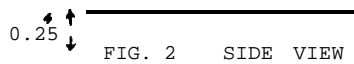

FIG. 2 SIDE VIEW



FIG. 3

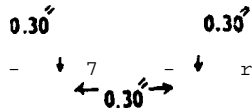
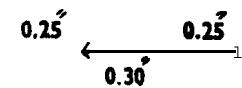

FIG. 4

# U - TUBE MANOMETER

## Materials required for construction

1.  $1\frac{1}{2}$ " x 4" x 5" wood base.
2.  $1\frac{1}{2}$ " x 4" x 10" wood upright.
3. 20" polyethylene tubing.
4. One large balloon.
5. 24" of rubber tubing.
6. Four pieces of metal strapping, each  $1\frac{1}{2}$ " long.
7. One funnel.

## Procedure for construction

1. Cut and sand the base and upright. Join them with nails.  
proper shape and punch holes in it for the nails. Be careful not to pinch the tubing with the strapping.
2. Apply two coats of varnish to the wood pieces and allow it to dry before attaching the tubing.
3. Mark guide lines along the upright  $\frac{3}{4}$ " from each edge and parallel to the edges.
4. Using these guidelines, attach the polyethylene tubing to the upright with the metal strapping as shown. Before attaching the strapping, bend it to the proper shape and punch holes in it for the nails. Be careful not to pinch the tubing with the strapping.
5. Make a graph paper scale wide enough to fit between the vertical parts of the tubing and attach to the upright.
6. To make a U-tube manometer, take a piece of rubber from a large balloon and place it over the mouth of a funnel such that it forms a tight diaphragm. Wrap a few turns of string around it to secure it in place on the funnel. Join the funnel apparatus to the U-tube with a 2' piece of rubber tubing.

## Uses in practicals and demonstrations

1. To demonstrate that pressure in a liquid is equal in all directions.
2. To find the specific gravity of liquids which do not mix with water.
3. To measure gas and liquid pressures quantitatively.

## Questions for further study

1. What difference would it make if you used mercury in the U-tube instead of water for measuring specific gravities?
2. Can you use the manometer to show that a gas, just like a liquid, transmits pressures exerted on it equally in all directions?
3. Do different liquids exert the same pressure at equal depths?
4. Can you find the pressure of flowing water?
5. Diffusion of gases can be demonstrated with the manometer. Using the manometer, investigate the pressure created by gas diffusion.
6. How would you use the U-tube to investigate the effect of different climates on the rate of transpiration?
7. Without any modifications, will the manometer act as a barometer. If not, how would you modify it so that it would do so?

## SHORT INTERVAL TIMER

### Materials required for construction

1.  $3/4" \times 3/4" \times 7"$  wood piece- A.
2.  $3/4" \times 3/4" \times 9\frac{1}{2}"$  wood piece- B.
3.  $3/4" \times 3/4" \times 3\frac{1}{4}"$  wood piece- C.
4.  $1/16" \times 1\frac{1}{2}" \times 1\frac{1}{2}"$  glass piece.
5. 6" of glass tubing 8 mm in diameter.
6.  $3/16"$  bolt  $1\frac{1}{2}"$  long.
7. Two corks 8 mm in diameter.

## Procedure for construction

1. Take the 6" piece of glass tubing and check it with the tri-square to make sure that one side is perfectly straight.
2. Filter, boil and refilter a cup of water. Then aerate it and allow it to stand for two days. This procedure is necessary to remove all organic matter from the water which might later produce either  $\text{CO}_2$  or  $\text{O}_2$  and to bring the dissolved gas level of the water or normal.
3. Soak the two corks in water for two days. At the end of this time insert one cork into the end of the glass tubing. Push it in  $1/8$ " past the edge of the tubing and seal the end with sealing wax.
4. Fill the tube with the "treated" water. Insert the second cork part way, remove and reinsert it so that a small bubble of air is captured in the tube. The bubble must be about  $1/8$ " to  $3/16$ " in diameter- If it is not, repeat the above steps.
5. After you have obtained a bubble of the proper size, seal the second end with sealing wax. This way the bubble will remain the same size and the accuracy is assured.
6. Take Block "A" (mentioned above) and carefully check it, making sure that its sides are parallel and straight. This piece must be perfectly square. From this piece remove a triangular piece  $1/4$ "  $\times$   $2\frac{7}{8}$ " from one side of the piece— see diagram. Be sure that these new surfaces are absolutely straight.
7. Take Block "B" and make sure that it is **perfectly** square. On one side (see diagram) cut small notches  $1/8$ " deep by using your hand saw at locations 2", 4",  $5\frac{1}{4}$ " and 7" from end. Drill a  $3/16$ " hole  $1/2$ " from the end where you started measuring. At the opposite end and on the same surface where you cut the notches, measure off  $1/2$  of the thickness and remove for  $3/4$ " length. See diagram. Thus you have a board which is  $1/4$ " thick for the last  $3/4$ " of its length. This piece is to fit in block "C".
8. Block "C" is to have a notch  $3/4$ " long and  $1/2$ " deep removed from the centre of one side. Blocks "B" and "C" must fit squarely and tightly. Nail them together.
9. Insert  $1\frac{1}{4}$ " long nails into the ends of block "C" so that the ends of the nails stick out of the bottom of this block forming two "feet".
10. Draw a line across the width of block "B", 4" from the end with the hole drilled in it. Mark this line with a heavy pencil so that it can be seen through a coat of varnish.
11. Varnish all the wooden pieces. When varnishing block "B", place one edge of the glass piece on the line (as shown in the diagram) with its other edges sticking out  $1/4$ " over the width

# SHORT INTERVAL TIMER

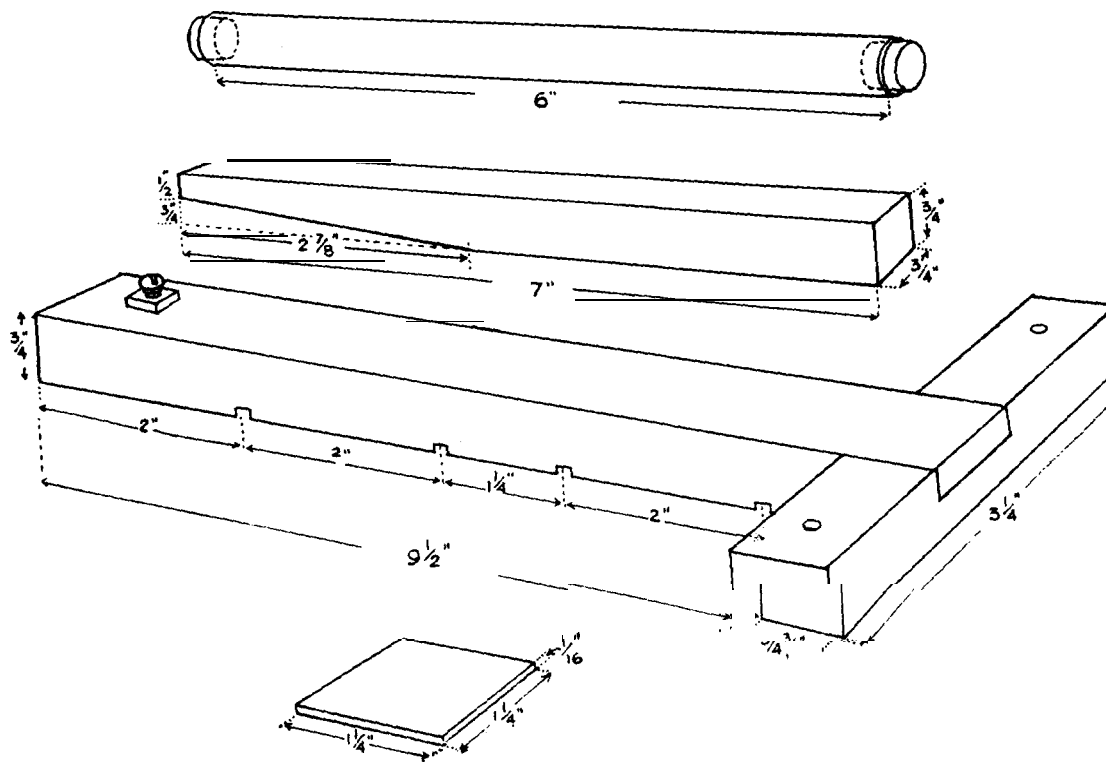
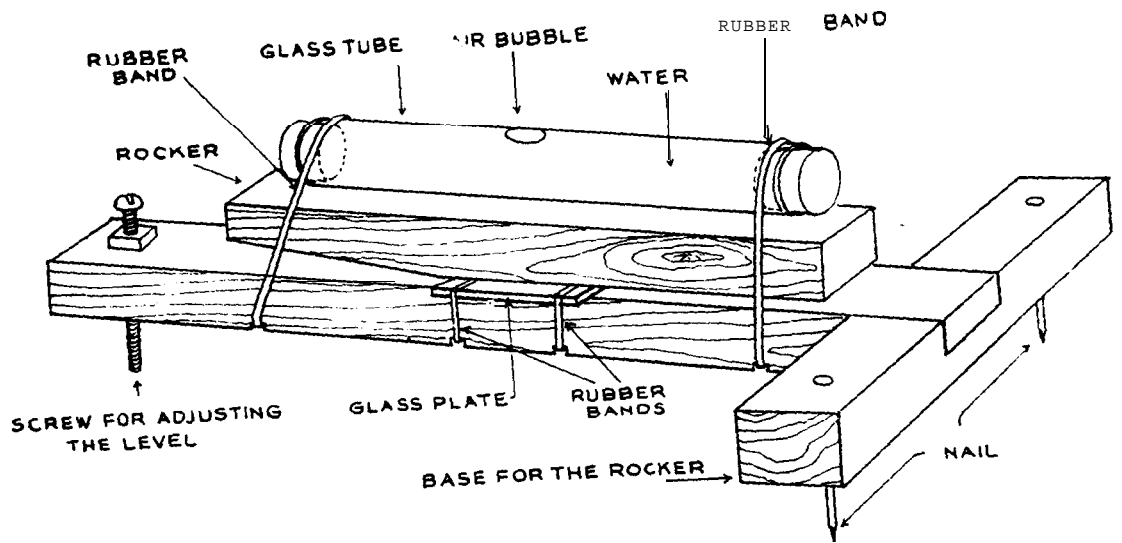

of block “**B**” on both sides. When the varnish dries, the glass piece should stick permanently.

**12.** Insert the bolt into the hole in block “**B**”.

**13.** Assemble the glass tubing as

shown in the diagram.

**14.** Add the rubber bands to the apparatus as shown in the diagram.

**15.** Check to make sure that the straight side of the glass tubing is on **top**.

### Calibration

**1.** Use a stop watch, clock with a second hand or a simple pendulum with 60 swings per minute.

**2.** Check to see that the tube is **level**—the bubble will not move in the level position. Check at different locations. Adjustment can be made by using the bolt on the end.

**3.** To calibrate the 0.1 second interval, move the bubble over to the side with the triangle removed, Mark the centre of the bubble’s resting point as “zero”, press down on that end for a period of two seconds—one must push quickly and evenly without jerking the apparatus. At the end of the two second interval carefully but quickly release the pressure on the block—the bubble will stop immediately. Mark this spot (the stopping point of the centre of the bubble) and repeat this ten times. The

average position of those obtained will be your two second mark. Divide the length between the two points into twenty equal intervals—thus each interval represents 0.1 of a second. Test for a short interval to check the accuracy.

**4.** To calibrate the **15** second interval again make sure that the tube is level. Bring the bubble to the end which didn’t have the triangle removed; mark the centre of the bubble’s resting point as “zero”. Press quickly and carefully on this end of the block and release after 15 seconds. Mark the **15** sec. spot and repeat this operation 10 times to find the average point. Mark the average point, which is your averaged **15** second mark, and divide the interval between 0 and **15** into 15 equal intervals — each division representing one second.

### Uses **ipracticals** demonstrations

This piece provides you with a timer capable of measuring tenths of seconds accurately up to 15 seconds, Of course, it is not meant to replace a stop-watch. Rather, it is meant to supplement the equipment which is available for student use.

# ELECTRIC MOTOR

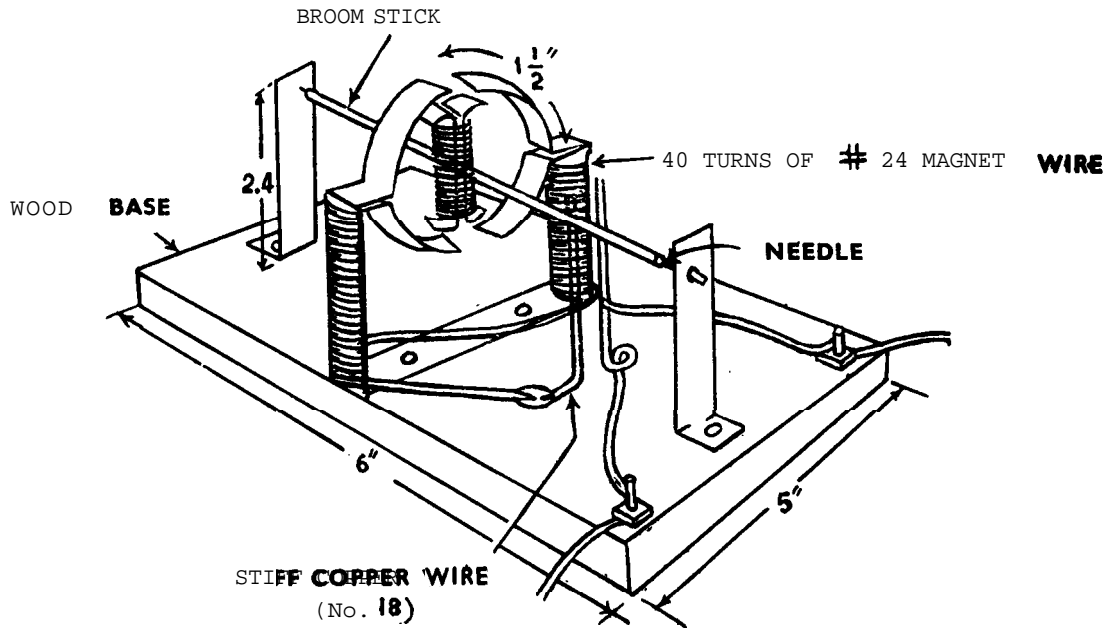

1 13" STRAPPING

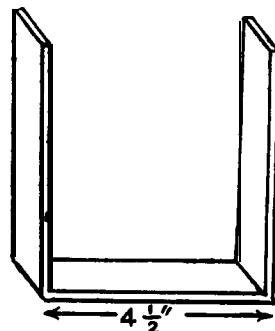

FOR ELECTROMAGNET

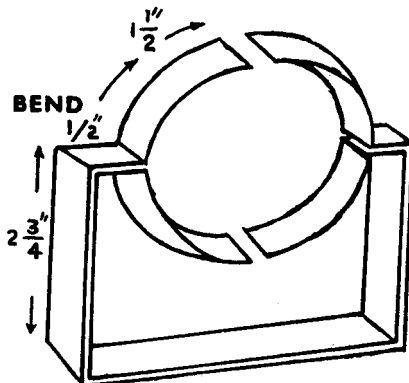
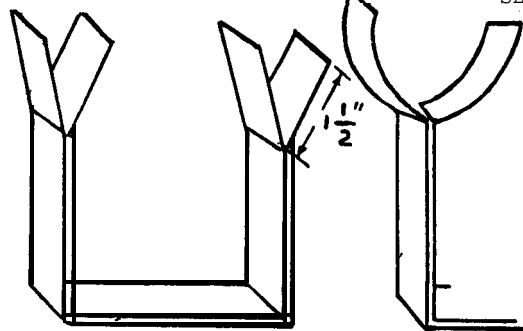

(II) 2" STRAPPING FOR ROTOR

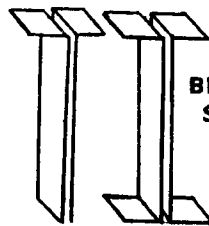

BROOM STICK



ADHESIVE PLASTER



# ELECTRIC MOTOR

## Materials required for construction

1. Two pieces of strapping **13"** long.
2. Two pieces of strapping **2"** long.
3. Two pieces of strapping **3½"** long.
4. One **3"** broomstick.
5. **24** gauge magnet wire.
6. One **1/2" x 5" x 6"** wood base,
7. Two bolts and four nuts.
8. Four screws.
9. **18** gauge **enamelled** copper wire for brushes.
10. Adhesive tape.
11. One dry cell to run motor.

## Procedure for construction

1. Cut, sand and varnish the base.
2. Take the two **13"** strapping pieces and bend them together into a "U" shape so that the arms are **4½"** each and the base **4½"**.
3. **Measure 1½"** from the free ends and then bend them apart like a "V".
4. Shape the parted ends to form a semicircle of **2"**diameter (Fig. B & C).
5. Measure **1/2"** down the semicircle and bend the two arms inside (Fig D).
6. Take the **2"** pieces **of** the rotor and and shape them as shown in **Fig.II**.
7. Put the broomstick in between them and keep it in position by means of adhesive tape.
8. Take the **3½"** pieces of **strapping**. Bend **2.7"** part of it at right angles to the remaining part, forming the up-rights
9. Drill small holes **2¼"** above the bend in the strapping.

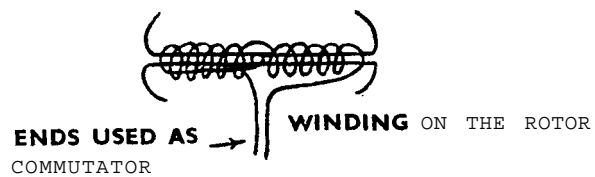
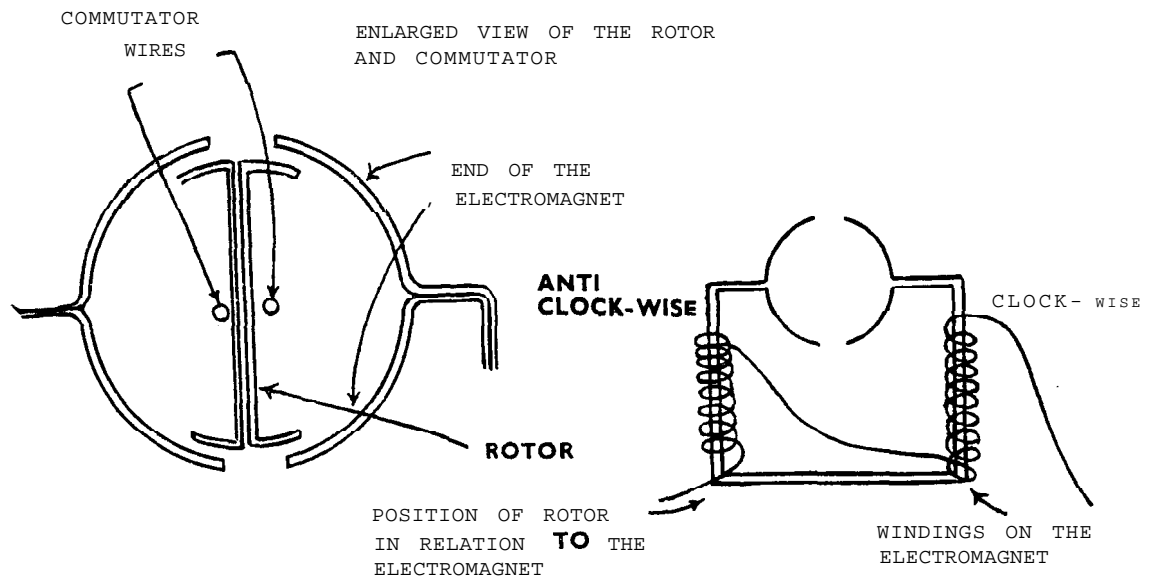
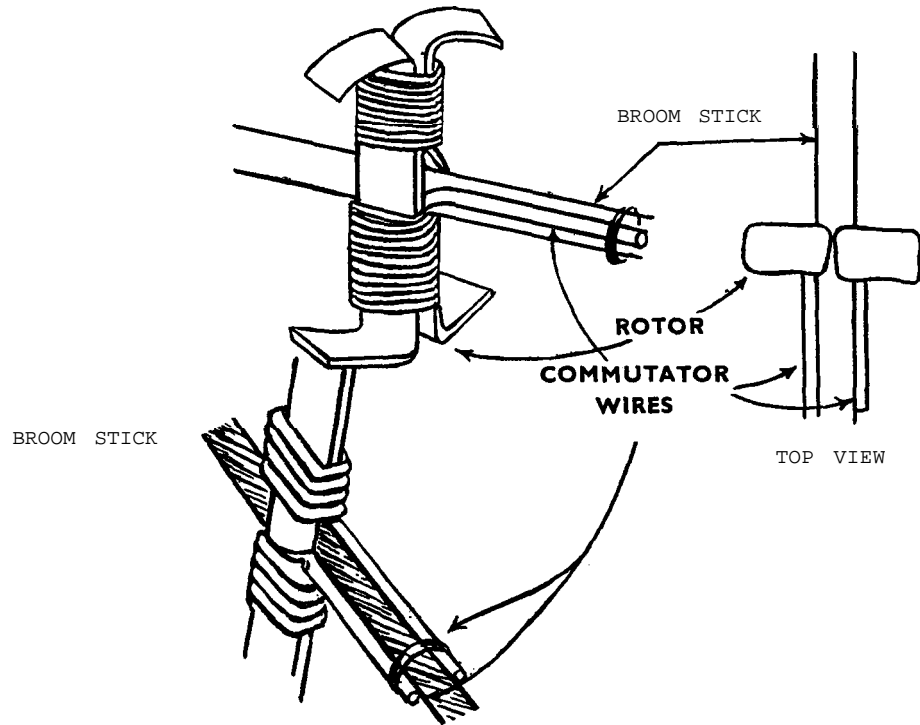

**10.** Wind 60 turns of No. 26 magnet wire on each arm on the electro-magnet. It should be clockwise on one arm and anti-clockwise on the other.

**11.** Wind 40 turns of No. 26 wire on the rotor leaving 1" ends of it free. Sand the ends to remove insulation.

**12.** Place the ends along and on opposite sides of the broomstick. Fix their ends with small pieces of adhesive tape. The plane of these two wires should be at right angles to that of the rotor blades (see diagram).

**13.** Stick a pin in each end of the broomstick.

**14.** Fix the electromagnet in the centre of the base parallel to the width. Use nails.

**15.** Fix the upright bearings as shown

in the figure. They must be in a line..

**16.** Assemble the rotor.

**17.** Cut two pieces of **18** gauge **enamelled** copper wire. Sand them to expose the metal. Bend and fix them to the base by means of screws. They must touch the bare copper ends of the rotor on the broomstick.

**18.** Connect one **brush to one end of the wire on the electoromagnet.**

**19.** Connect the second end of the wire on the electromagnet to one of the terminals on the base.

**20.** Connect the second terminal by means of a wire.

**21.** Connect the terminals to one good "D" size dry cell and your motor should run.

### Uses in practicals and demonstrations

This should be found useful when teaching about electromagnetism and **electric** motors. It provides a cheap and graphic demonstration of an electric

motor and is easy enough to construct that a student with no experience should be able to construct his own working model.

### Notes on use and construction

Trouble shooting your motor will, at times, be necessary. There are usually a few important things to be checked **before** attempting to run the motor. Make

sure that the brushes are free from **corrosion**, and before each demonstration they should be sanded to ensure the best performance. Of course, the connections

should be double checked before performing any demonstrations with this piece. If after these things have been done and the motor still doesn't work, check your battery or add another battery and see if **it** will work. If not, check the winding of your coils and re-read the plans to make sure that you followed them correctly. After the demonstration you may want to ask your students questions like these:

1. What should be the minimum distance between the rotor circle and the **stator** coil?
2. If the number of windings on the

rotor and **stator** are equal, what will happen?

3. What effects will the length of the broomstick have on the operation of this motor?
4. What happens if the commutator ends are kept in a plane parallel to the plane of the rotor?
5. State the conditions of the **stator** and the rotor when current is fed into the coils,

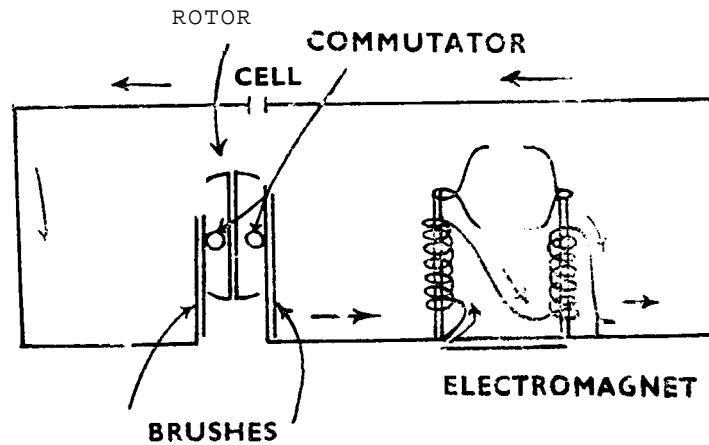

CIRCUIT DIAGRAMS

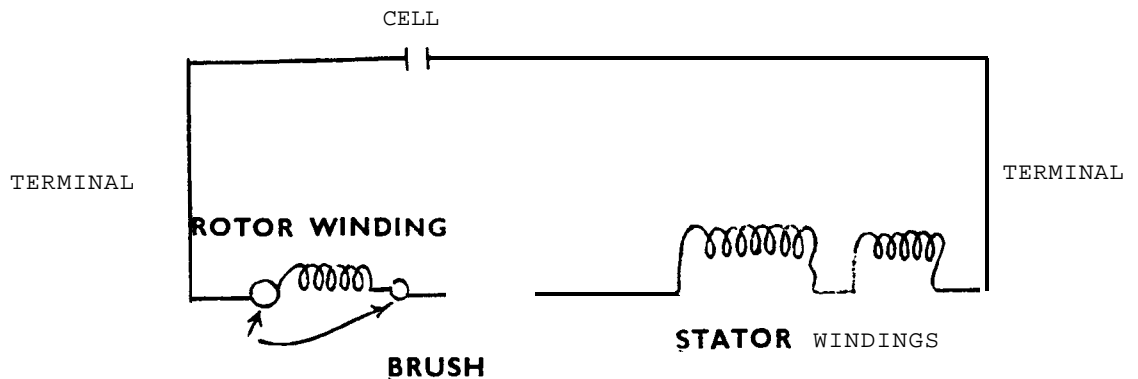

# DEFLAGRATING SPOON

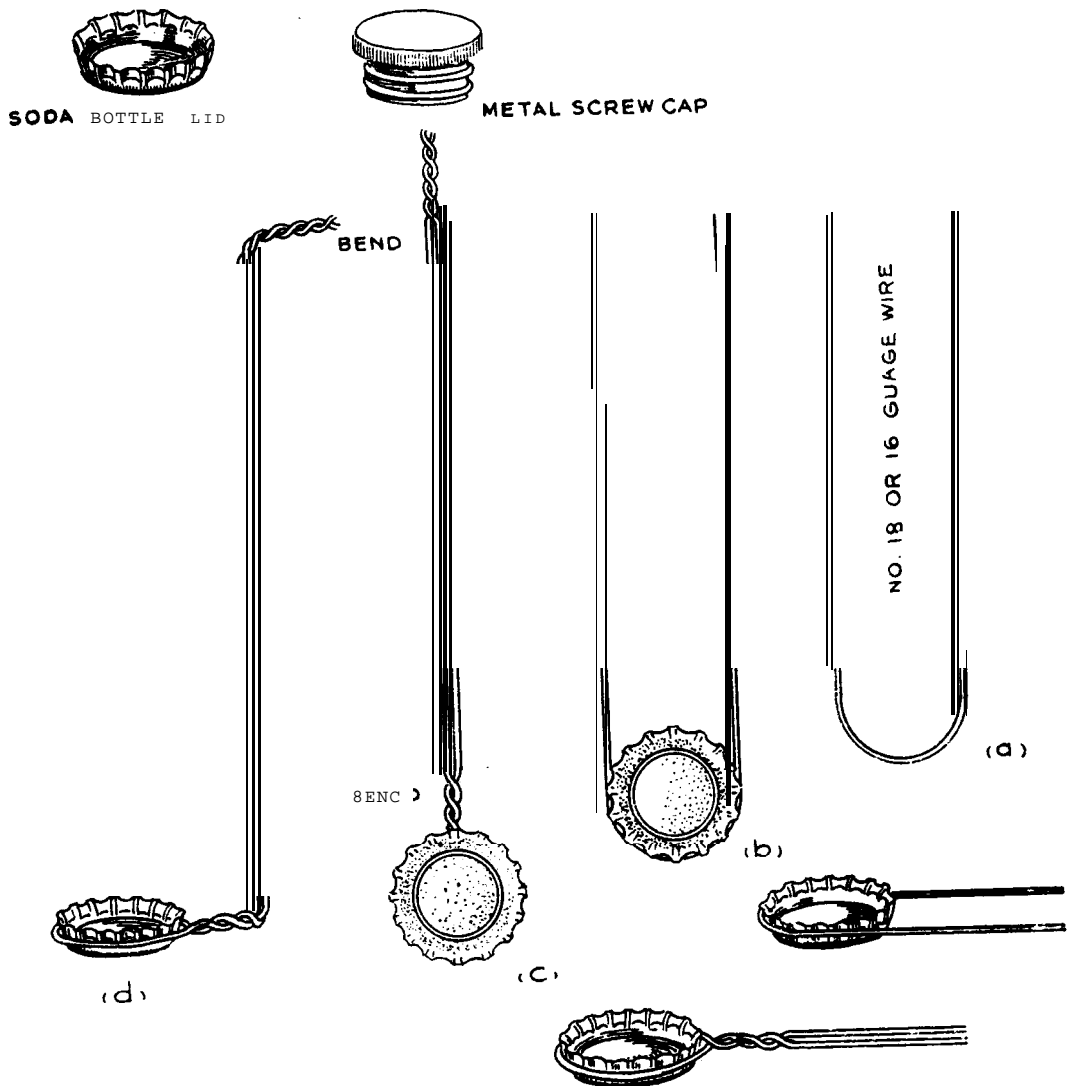

## DEFLAGRATING SPOON

### Materials required for construction

1. Soda bottle cap or metal bottle cap of 1" diameter.
2. One foot of **thin** wire.

### Procedure for construction

1. Make a circle at the middle of the wire to fit the soda lid.
2. Fix the lid in it and twist the end of the wire to the remaining part so that the lid is gripped tightly.
3. Bend the wire away from the bottom of the lid at right angles to the plane of the lid.
4. Bend the free end of the wire away from the bottle cap to serve as a handle.

# CARBON ARC FURNACE

## Materials required for construction

1. One earthen (clay) pot.
2. One drain tile.
3. Three  $1\frac{1}{2}$ " x  $3\frac{1}{2}$ " x 7" wood pieces.
4. Two large corks.
5. 16" of heavy wire.
6. Two used "D" size cells,
7. Water rheostat-see plans, this chapter.
8. Electrical wire.

## WATER RHEOSTAT

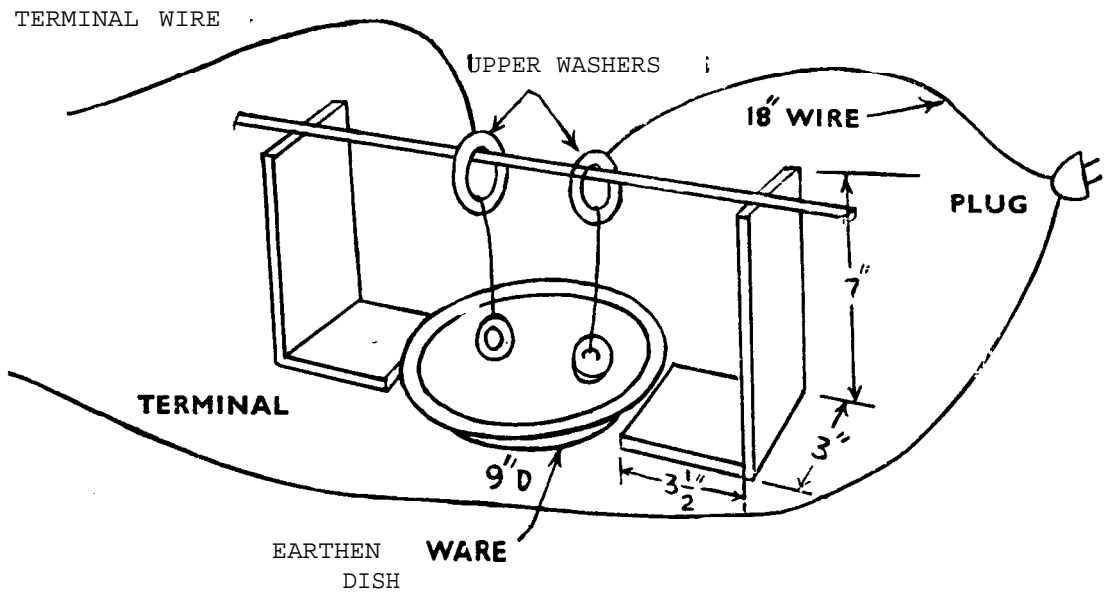

## CARBON ARC FURNACE

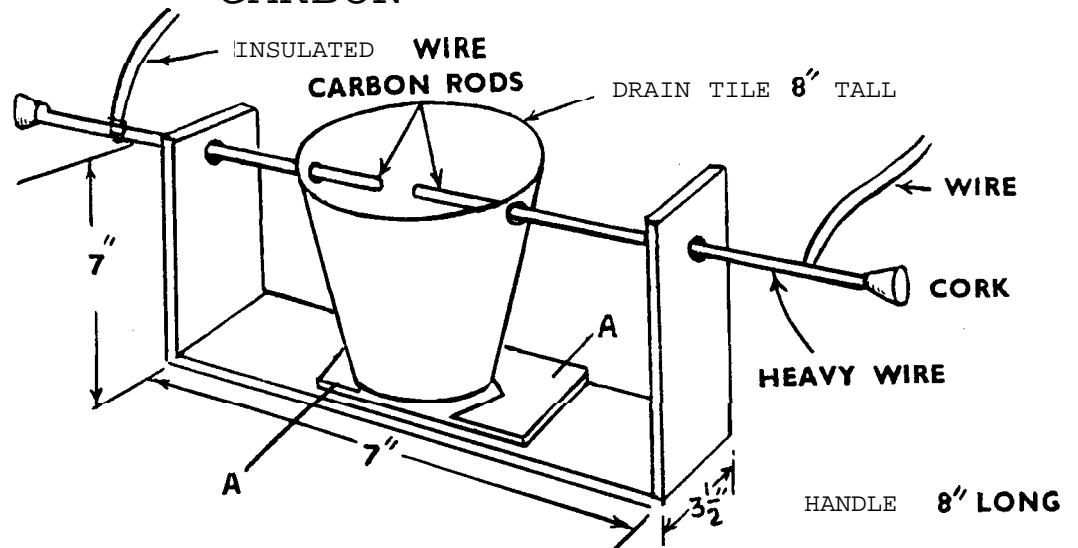

## Procedure for construction

1. The bottom dimension of the drain tile that we used was about 3", so we used  $3\frac{1}{2}$ " wide wood. Construct the wood stand as shown in the diagram.
2. The wood pieces "A" (see diagram) should be cut and nailed into place. They are to hold the tile into position.
3. Drill  $1/4$ " holes in both wood, up-rights and in the earthen pot.
4. Remove the carbon rods from two used "D" cells.
5. Cut two wire pieces each about 8" long. Attach one carbon rod to each wire by wrapping some light wire around the rod and heavy wire.
6. Fasten the corks securely to the heavy wires. They will serve as insulated handles. Secure the corks with glue or sealing wax.
7. The rod-wire-cork assemblies should be threaded into place and the apparatus should be connected to the wall current through the water rheostat.

### *Caution :*

When using the carbon arc, wear dark glasses. Do not touch the metal of the apparatus and be sure that anything that you may place in the arc is insulated and dry.

## Uses in practicals and demonstrations

The carbon arc is used to generate heat at temperatures which melt glass easily. It may be used for glass **working or** for other operations which require intense heat.

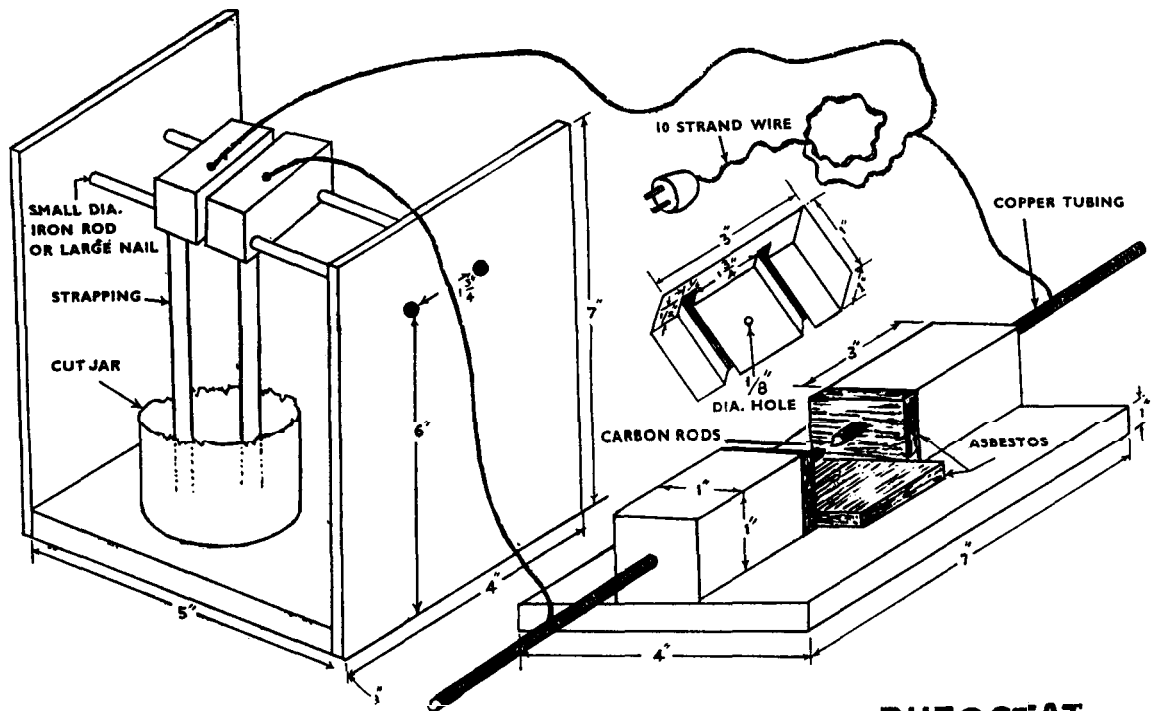

ALTERNATE **DESIGN FOR** CARBON ARC AND **RHEOSTAT**

## SALT WATER RHEOSTAT

### Materials required for construction

1. Two  $1\frac{1}{2}$ " x 3" x 7" wood uprights.
2.  $1\frac{1}{2}$ " x 3" x 12" wood base.
3. One earthen (clay) bowl.
4. One bamboo piece 14" in length.
5. Four large washers.
6. Insulated wire.



## Salt Water Rheostat Continued

### Procedure for construction

1. Cut and sand the wooden pieces given in 1 and 2 above.
2. Nail the uprights to the base as shown in the diagram.
3. Connect the washers with insulated wire as shown in the diagram.
4. Place the bamboo piece over the ends of the upright as illustrated and thread the washers on the bamboo as shown.
5. Place the connected washers in the earthen bowl and fill the bowl with water.
6. Connect the electrical terminals as shown.
7. Put a little salt in the water and plug-in the rheostat. Add more salt as needed and manipulate the amount of current desired by changing the distances between the two washers in the bowl.

### Uses in practicals and demonstrations

This rheostat is needed when used in conjunction with the carbon arc lamp or furnace. It provides enough resistance so that wall current may be used.

### Notes on use and construction

When using this piece of apparatus you should first adjust the washers so that they are fairly widely separated. Then add small amounts of salt to the water until current begins to flow. The

amount of current may be adjusted by manipulating the distances between the washers but try to avoid adding more salt to the solution after the current has begun to flow.

# KIPPS GAS GENERATOR

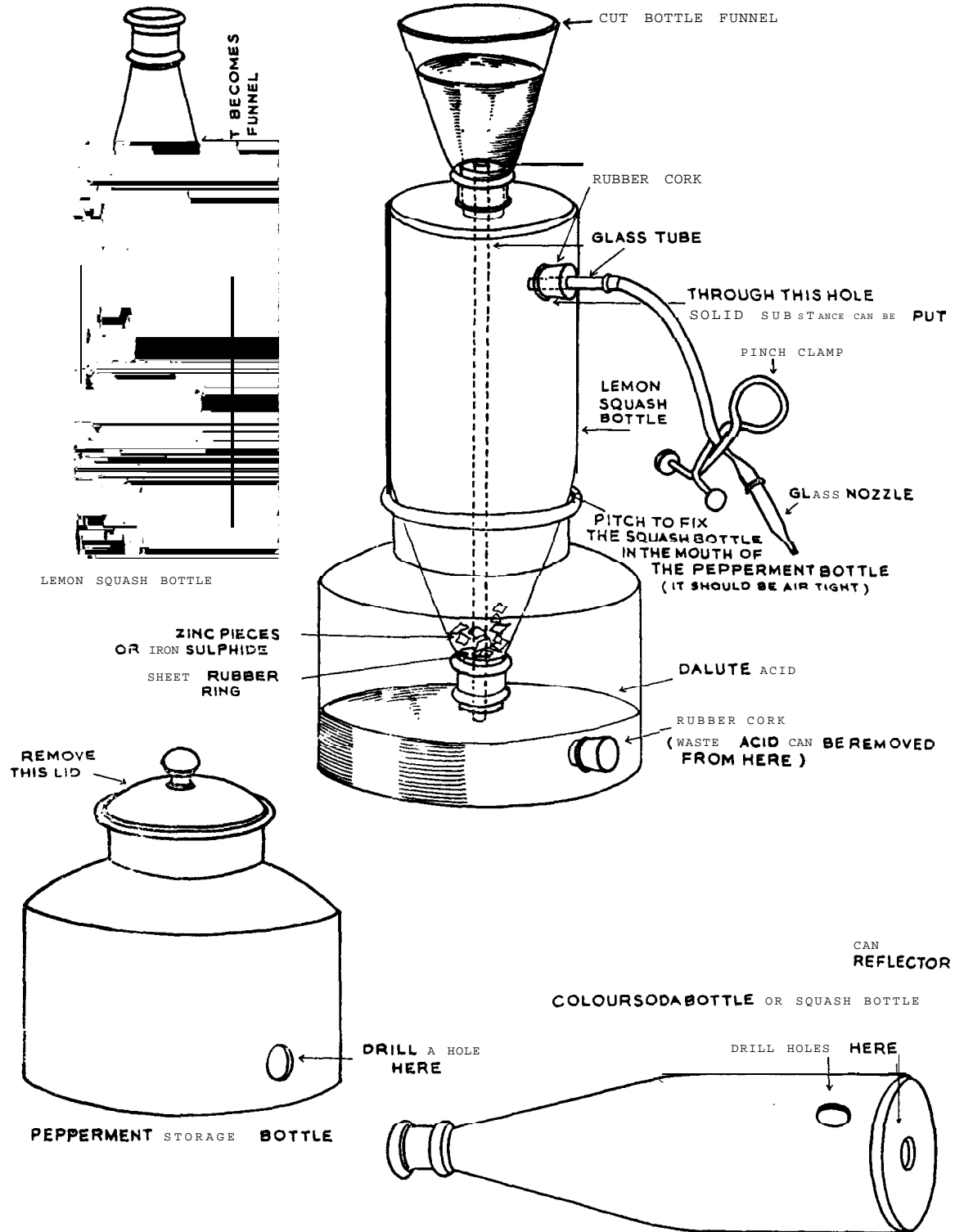

# KIPP'S GAS GENERATOR

## Materials required for construction

1. One peppermint bottle with wide mouth (bottom 6" diameter and the mouth 4" diameter).
2. One lemon squash bottle 8" high.
3. One bottle with conical neck.
4. 14" of glass tubing.
5. Two one-holed rubber stoppers.
6. One rubber stopper without a hole.
7. Rubber tubing.

## Procedure for construction

1. Make a hole in the side of the peppermint bottle just above the bottom.
2. Close it with the holeless rubber stopper.
3. Make a hole on the side of the squash bottle just above the bottom.
4. Drill another hole in the centre of the bottom.
5. Cut the bottle with the conical neck just below the cone. This conical part serves as a funnel.
6. Insert 12" of glass tubing in the one-holed rubber stopper and connect the bottom of the squash bottle and the funnel as shown in the diagram-
7. Fix the mouth of the squash bottle in the neck of the peppermint bottle (see diagram).
8. Seal the connection with the black pitch ("wadakilu") it is sold in the hardware shop. It is a black solid which melts on heating and the hot liquid looks like tar.
9. Assemble the other parts as shown in the figure. Take a rubber piece with a hole in its centre and insert it into the mouth of the squash bottle. It will serve as a "platform" for the solid chemical used (zinc, iron sulfide etc).
10. You may use a metal grip clip as the pinch cock or you may improvise one from heavy wire.

## Uses in practicals and demonstrations

This piece is a required piece of apparatus in your syllabus. However, by improvising one, the student should be better able to come to an understand-

ing of the principles involved in its operation. It will also serve adequately if you don't have this piece in your laboratory.

# DROPPING FUNNEL

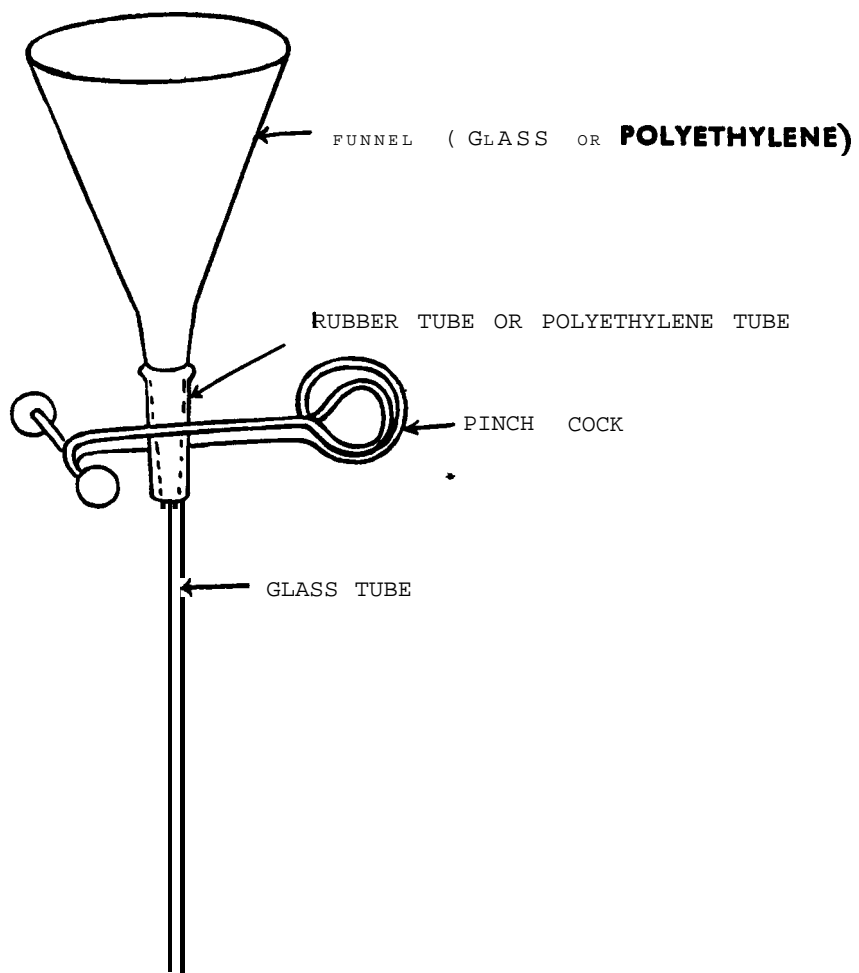

## SAND BATH

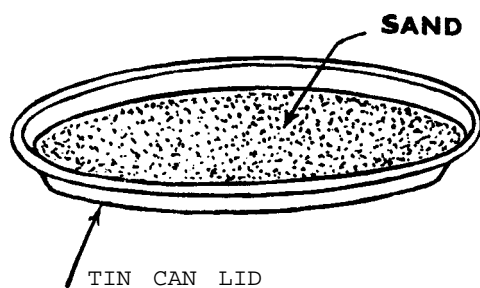

## WATER BATH

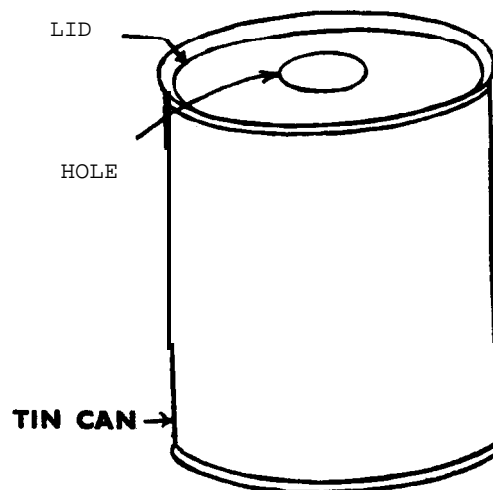

## **D R O P P I N G   F U N N E L**

### **Materials required for construction**

1. One glass or plastic funnel.
2. 6" to 8" length glass tube.
3. One pinch cock.
4. A few inches of rubber tubing.

### **Procedure for construction**

1. For construction see diagram.

## **S A N D   B A T H**

### **Materials required for construction**

One tin can lid of 4" to 6" in diameter.

### **Procedure for construction**

1. See diagram.

## **W A T E R   B A T H**

### **Materials required construction**

1. One tin can with lid.

### **Procedure for construction**

1. A hole of 1" diameter is made in the lid of the can.

# SIMPLE MICROSCOPE

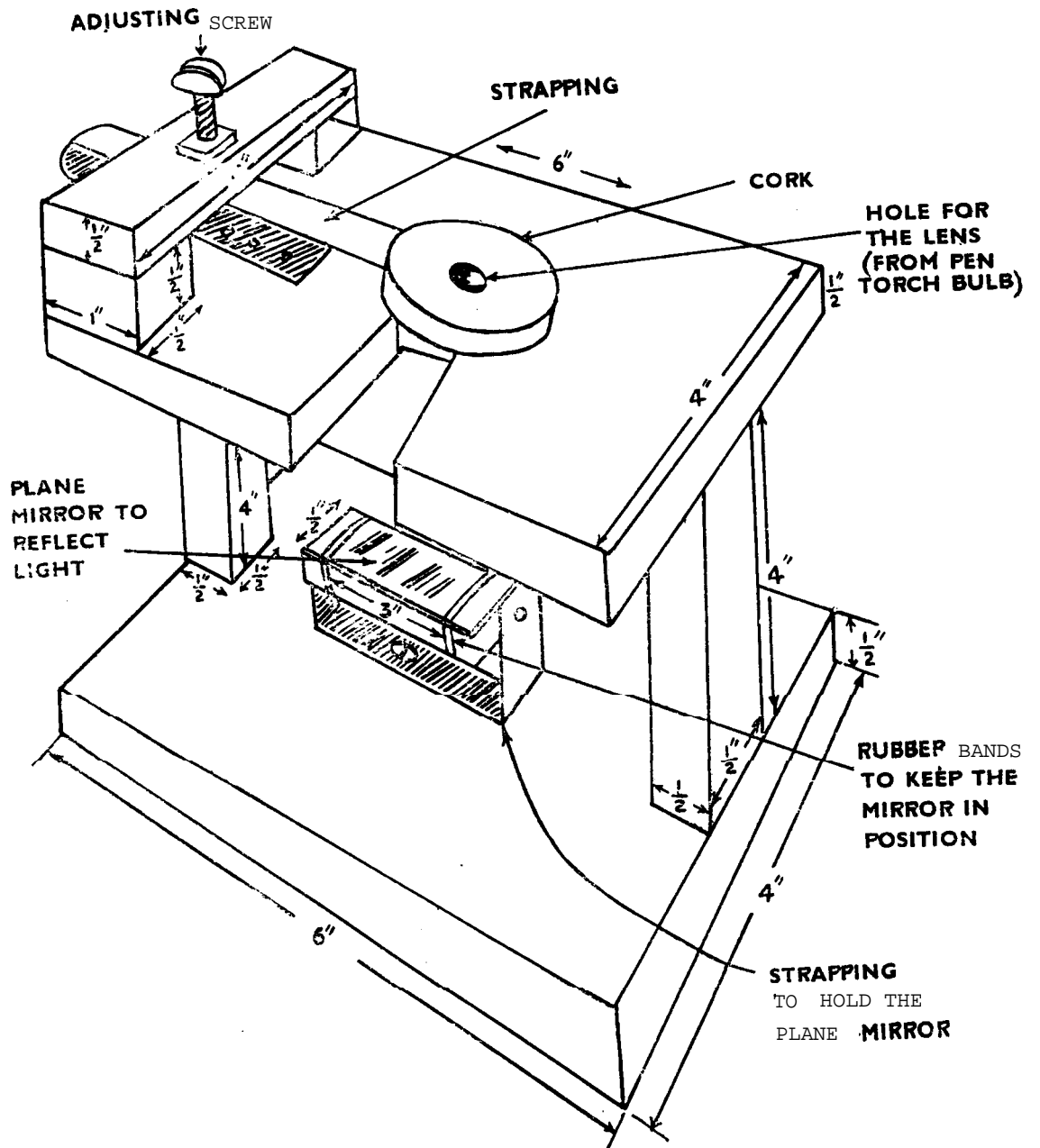

# S I M P L E    M I C R O S C O P E

## Materials required for construction

1. Two  $1/2'' \times 4'' \times 6''$  wood pieces.
2. Two  $1/2'' \times 1/2'' \times 4''$  wood pieces.
3.  $1/2'' \times 1/2'' \times 4''$  wood pieces.
4. One penlight bulb.
5. Two  $1/2'' \times 1/2'' \times 1''$  wood pieces.
6. One  $3/16''$  diameter bolt and nut  $3\frac{1}{2}''$  long.
7.  $8''$  of metal strapping.
8. Mirror piece  $1/2'' \times 3''$ .
9. Two rubber bands.

## Procedure for construction

1. Cut and sand wood pieces given in 1, 2, 3 and 6 above. place such that it can be rotated to get the best light.
2. Take five inches of strapping and bend up at  $90^\circ$  one inch from each end. Use a large nail to punch nail holes in the 3'' section of the bracket. Also, punch small holes on the 1'' sections which will later receive the mirror mounting. Nail the bracket to the centre of the 4'' x 6'' wood base as shown in the diagram.
3. Place the mirror strip on the  $1/2'' \times 1/2'' \times 3''$  wood piece and secure with rubber bands. Place this assembly between the uprights of the bracket which you just completed and tack it in
4. Nail the  $1/2'' \times 1/2'' \times 4''$  uprights to the base.
5. The  $1/2'' \times 4'' \times 6''$  wood piece is the stage. Cut a notch 1'' wide and 2'' deep as shown in the drawing.
6. Nail the  $1/2'' \times 1/2'' \times 1''$  blocks to the narrow (3'') end of the stage as in the drawing.
7. Nail this assembly to the  $1/2'' \times 1/2'' \times 4''$  wood uprights.

8. Drill a  $3/16$ " hole in the middle of the  $1/2$ "  $\times$   $1/2$ "  $\times$  4" piece. This is to hold the adjusting screw.

9. Place the metal strapping on the stage as shown. Nail it on to the stage and be sure that the part nailed down does not come outside to interfere with the slide. Nail the  $1/2$ "  $\times$   $1/2$ "  $\times$  4" piece for the hardening, heat the nut and place over the hole and allow the wax to **harden.Thread** in the bolt-the end of the bolt touching the strapping should be filed to a point.

10. Take the penlight bulb and remove the front portion by scratching around

the circumference and then breaking. This is your lens.

11. Make a 1" circle out of a block of wood and it no thicker than  $1/2$ ". Drill a  $3/16$ " hole in the centre and widen with a file until the penlight lens fits snugly.

12. Cut a slit into the 1" circle allowing it to fit onto the strapping. You may have to put tape on the end of the strapping to get a tight fit.

13. Put the lens into the 1" eyepiece, attach to strapping and your scope is ready for use.

### Questions for further study

1. How can the lens magnify the objects ?

2. What sort of image is formed by the simple microscope ?

3. Where should the slide be placed? Why ?

4. Glass beads can be used as lenses. Prepare different size glass beads making sure that they are perfectly round and do not contain air bubbles. The glass bead is placed between two pieces of strapping so that the two holes in the strapping come over and below the bead. How does the magnification vary with the size of the bead?



# MICRO PROJECTOR

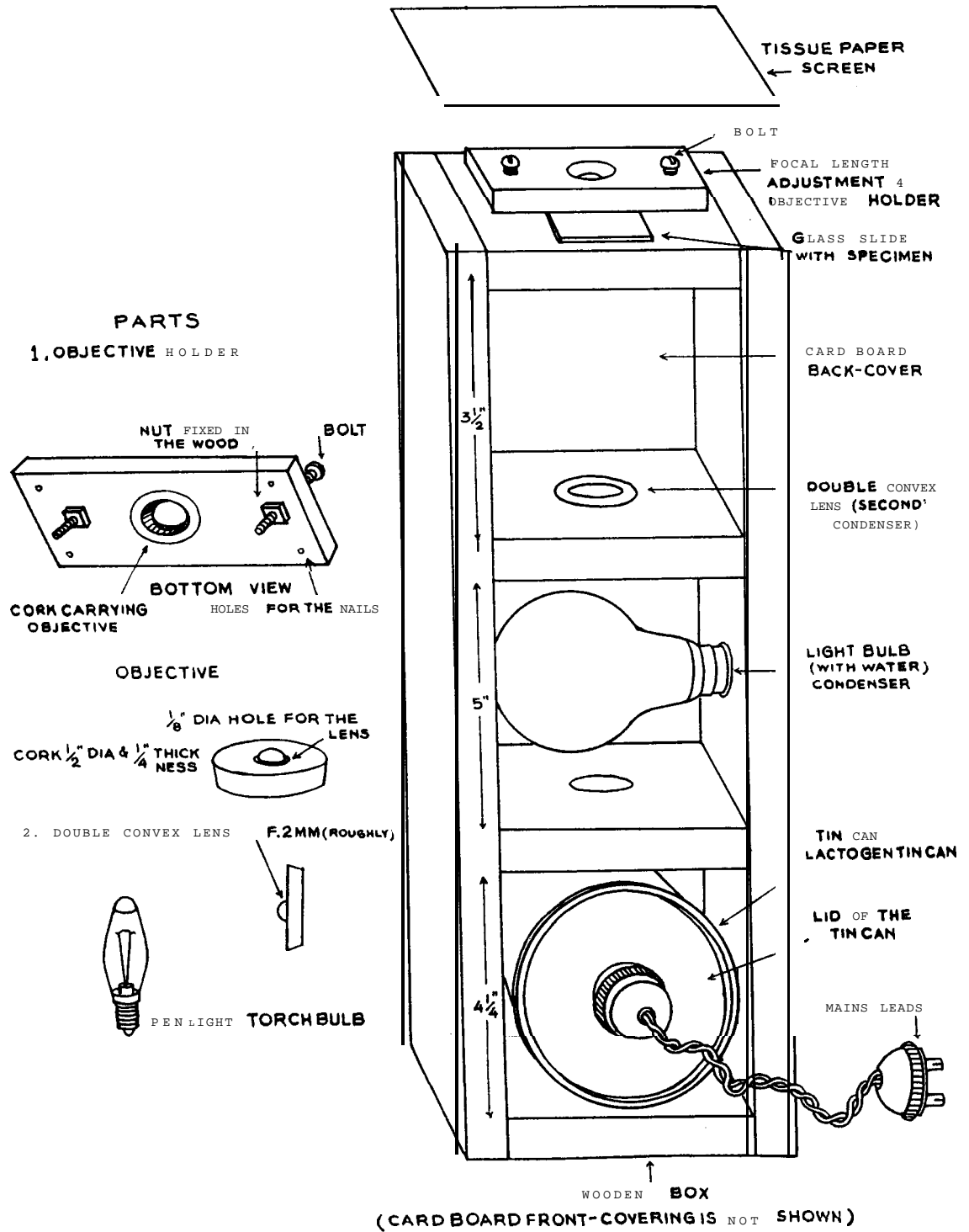

3. WOODEN BOX

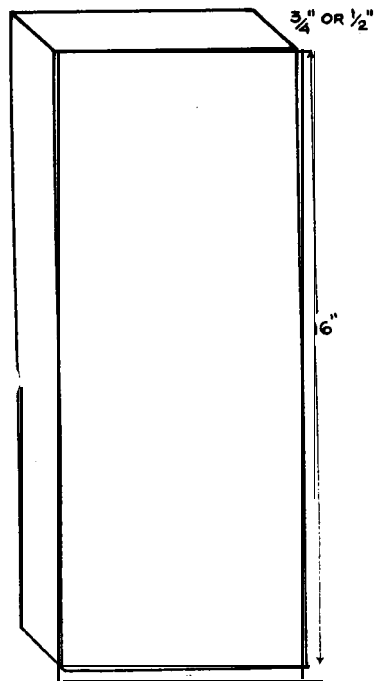

4. LIGHT SOURCE

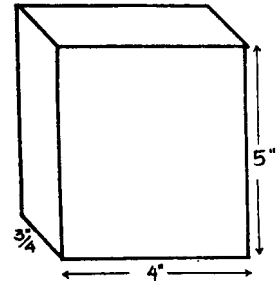

1 PIECE FOR THE BASE 3 PIECES FOR THE REST  
 THESE THREE MUST HAVE HOLES IN THE MIDDLE  
 (1/2" DIAMETER HOLES)

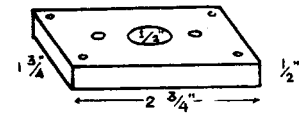

OBJECTIVE HOLDER  
 1 PIECE

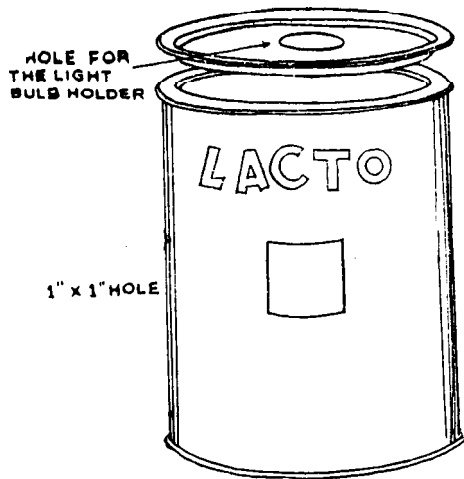

LID OF A LACTOGEN TIN  
 CAN (OR ANY OTHER SUITABLE  
 ONE)

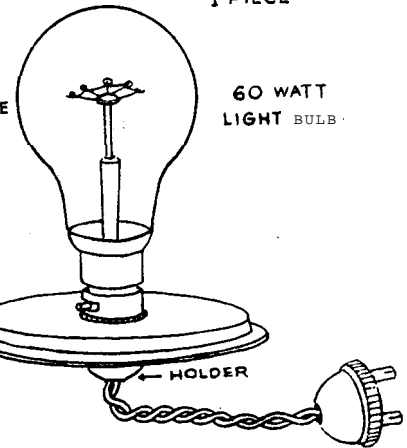

60 WATT  
 LIGHT BULB

FRONT CARDBOARD COVER

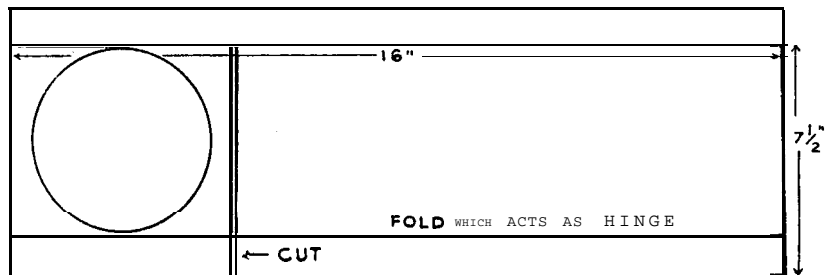

# MICROPROJECTOR

## Materials required for construction

1. Two  $3/4"$  x  $9\frac{1}{2}"$  x  $5\frac{1}{2}"$  wood sides.
2. Two  $3/4"$  x  $5\frac{1}{2}"$  x  $6"$  wood ends.
3.  $3/4"$  x  $6"$  x  $11"$  wood bottom.
4. One small "Champion Oats" tin.
5. One penlight bulb.
6. One 60 watt light bulb.
7. One light bulb socket.
8. Electrical wire.
9. One plug.
10. One burned out light bulb.
11. One rubber stopper.
12. One cork.
13. Strapping.
14. One piece cardboard  $4"$  x  $2"$ .
15. One piece light cardboard  $6"$  x  $2"$ .
16. Black paint.

## Procedure for construction

1. Cut a hole in the centre of one of the end pieces, and construct the box according to the diagram.
2. Cut the cardboard top, and cut a hole in it as shown.
3. Paint the inside black.
4. Cut a hole in the lid of the tin, so that the light bulb and socket will be held there (Figure 1). Cut a window in the side of the tin as shown in Figure 1. The light bulb should be just inside the window.
5. Clean the burned-out light bulb, fill with water, and cork it.
6. Make a stand for it by curving a piece of cardboard ( $6"$  x  $2"$ ) and fastening it as in Figure 2. The water filled bulb now sits on the stand, and may be placed in the box as shown in the main diagram. This bulb acts as a condensing lens for the light coming from the tin.
7. The botanical or zoological specimen slide is to be placed on the front end of the box. Fix pieces of strapping as shown in the diagram. The two flat pieces will hold a slide in place. The two bent pieces will hold the lens in place.
8. The lens is the same one or same type which is used for the simple micro-

# MICROPROJECTOR (DIFFERENT DESIGN)

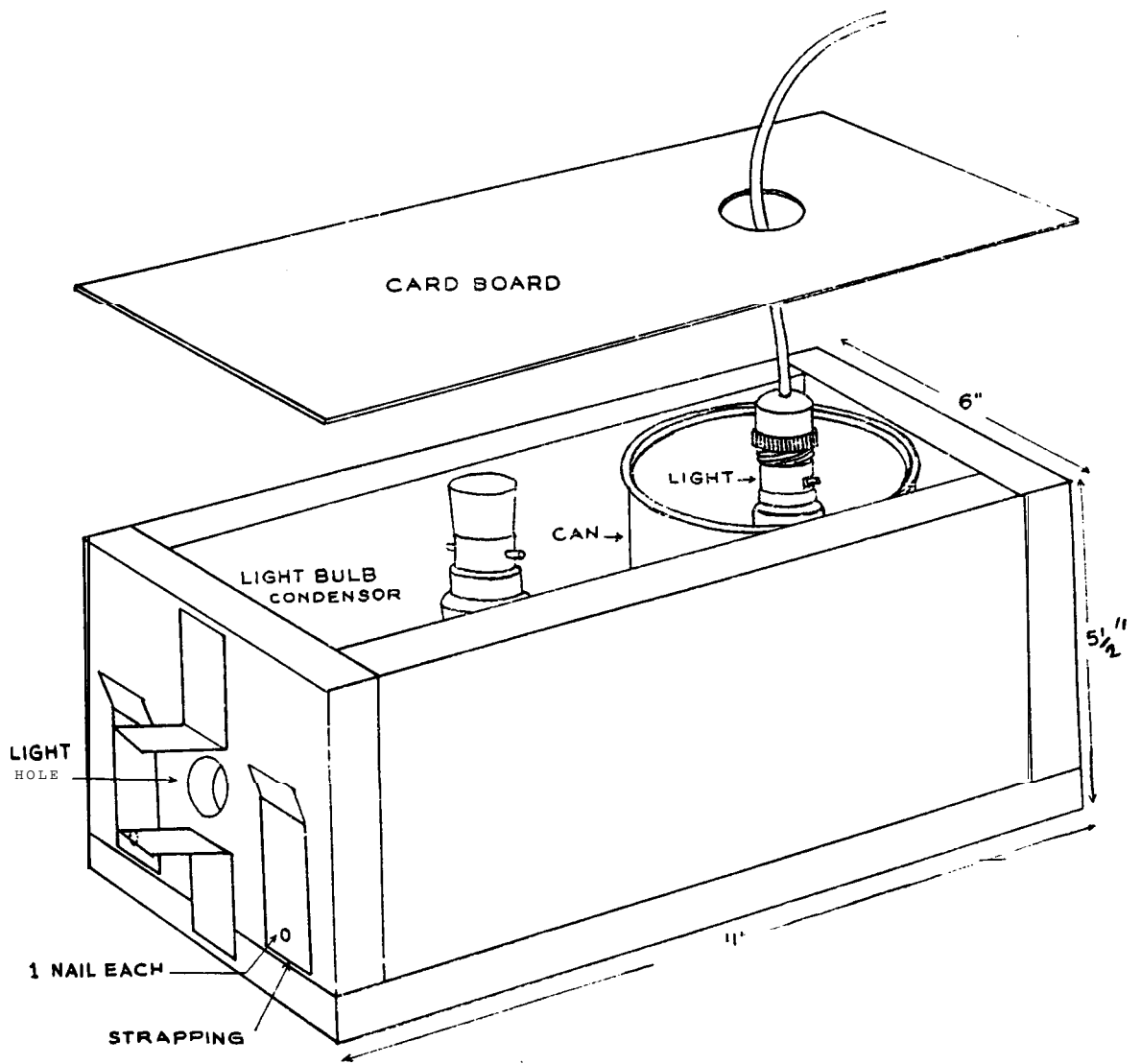

scope. It is taken from the tip of a penlight bulb. To mount it on the front of the box, **slice** a disk off one end of a cork (dark area, figure 3 ), mount it on a flat piece of cardboard (4" × 2") See Figure 4. Drill a small hole in the centre of the cork, through the cardboard, so that the lens may be placed there. Be sure that no light can escape around the edges of the lens.

9. With the lens mounted this way it may be attached to the front of the box.

**10.** Cut two slits in the cardboard (Figure 4), and slide the piece into the two bent pieces of strapping on the front of the box.

11. Prepare a screen by making a small wooden frame as shown in Figure 5, and by attaching a very thin **translucent**

paper as shown (we used the thin protective sheet of a stencil paper).

12. Place a glass slide underneath the strapping clips on the front of the projector. Now close all windows, turn out the lights, and darken the room. Place the screen a couple of feet in front of the box, and turn on the light.

13. A magnified image of the glass slide specimen will appear on the screen. For greater light concentration you may place a lens (optical bench lens holder) in front of the light bulb **condensor**. You must experiment with this projector in order to attain success with it. You must adjust the light source in the tin, you must adjust the light bulb condensing lens and the penlight lens, and you must adjust the slide specimen. However, with just a little practice **you** will be **able** to use this projector for class demonstrations.

### **Uses in practicals and demonstrations**

To project a magnified picture of cells, cross sections of leaves, roots, stems etc., on a screen allowing a large number of students to observe and participate in these types of demonstrations.

# MICRO PROJECTOR

( DIFFERENT DESIGN )

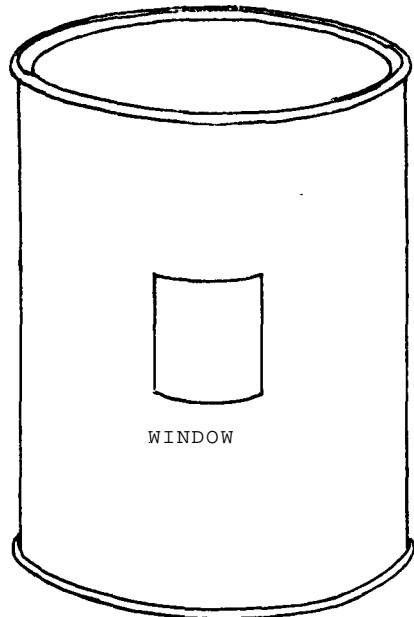

FIG. 1.

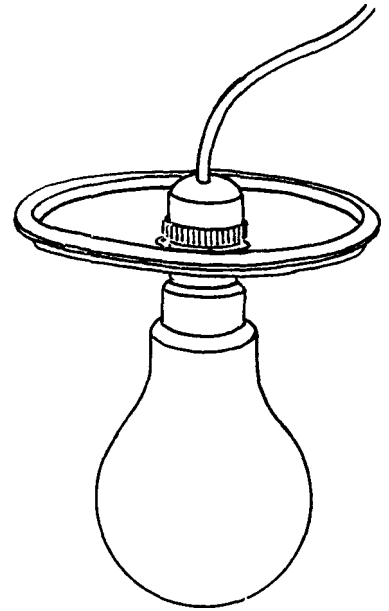

FIG. 2

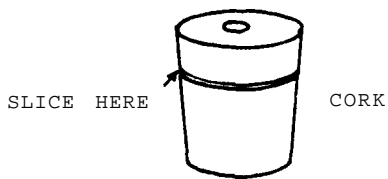
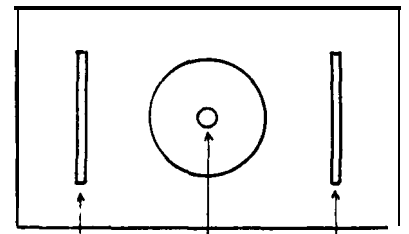

FIG. 3



SLIT LENS SLIT  
FIG. 4

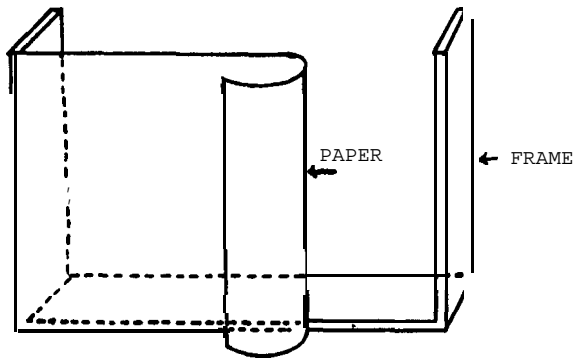
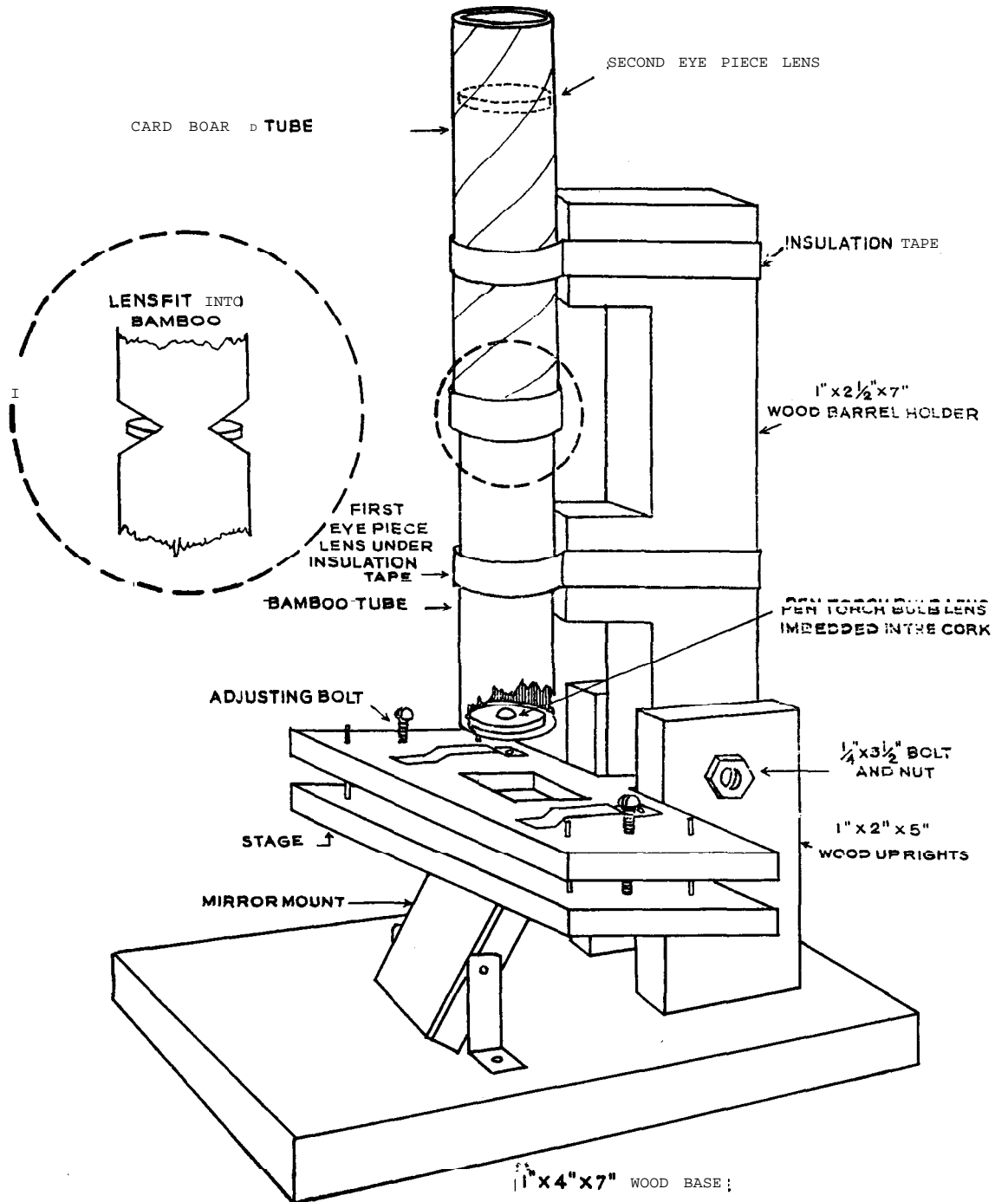

FIG. 5

# COMPOUND MICROSCOPE



# COMPOUND MICROSCOPE - PARTS

FIG. 2

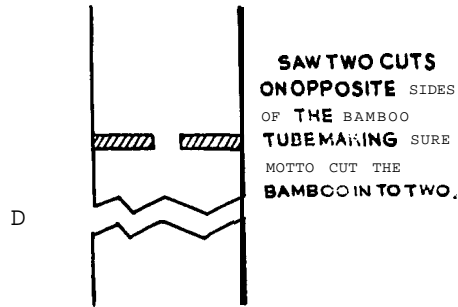

FIG. 3

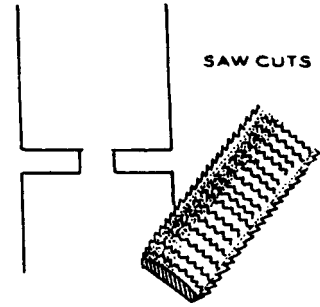

FIG. 5

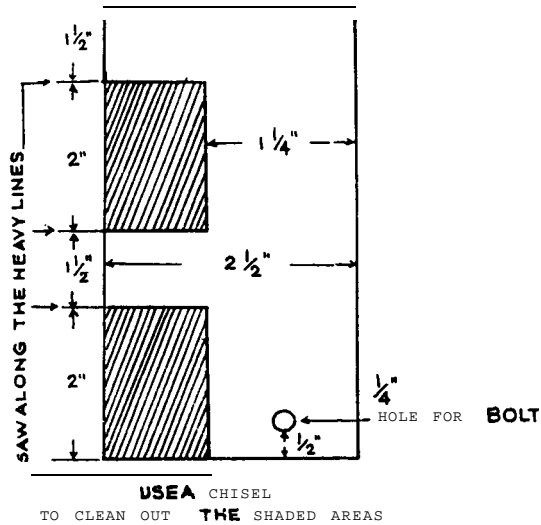
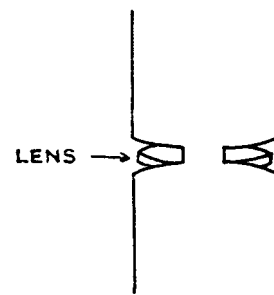

FIG. 4



BAMBOO TUBE WITH THE SAW CUTS ENLARGED AND THE EYE PIECE LENS FITTED IN TO PLACE.

FIG. 6

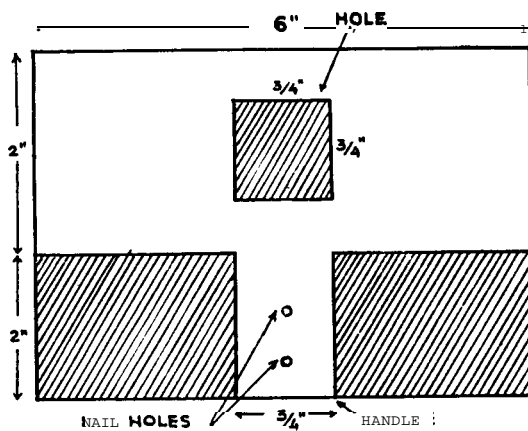
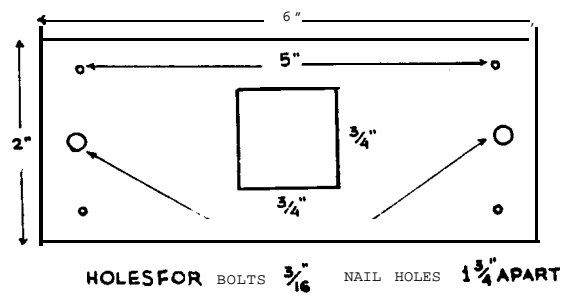

FIG. 7





# COMPOUND MICROSCOPE

## Materials required for construction

### Barrel.

1. One double convex lens from a pen torch bulb.
2. One 1" cork.
3. Two watchmaker's lenses with short focal lengths (5-10 cm).
4. One bamboo tube approximately 8" long and whose interior diameter is slightly less than the diameter of the eyepiece lenses.
5. Insulation tape.
6. Heavy cardboard.

### Barrel Holder

7. 1" x 2½" x 7" wood piece.

### Stage

8. 1/2" x 4" x 6" wood base piece.
9. 1/2" x 2" x 6" wood stage piece.
10. Two 2" pieces of metal strapping.
11. Two 3/16" nuts and bolts 1½" long.
12. Two 1" pieces of metal strapping.
13. 1½" thin wire nails.

### Stand

14. 1" x 4" x 7" wood base.
15. Two 1" x 2" x 5" wood uprights.
16. 1/2" x 1" x 2" wood mirror mount.
17. Two pieces of metal strapping 2½" long.
18. One 1" x 2" mirror.
19. 1/4" nut and bolt 3½" long.

## Procedure for construction

**Note:** The distance between the objective lens and the first eyepiece lens is a **definite unvarying** distance 'the length of which can be found with the formula  $D = S + F_e$  where is found in the formula :

$$\frac{1}{S} = \frac{-1}{(f + f_e)} + \frac{1}{f} \text{ or } S = lf,$$

where  $f$  is the focal length of the **objective** lens and  $F_e$  is the focal length of the first eyepiece lens.

The second **eyepiece** can be placed later without the **use** of a formula.

### 1. Fitting the eyepiece lens in the bamboo

At the distance '**D**' (see note above) from one end of the bamboo tube, make a saw cut less than halfway through the tube. Repeat this operation on the other side. Make sure not to **cut** all the way through.

2. Take the wood rasp and enlarge **the** cut on one side until it is large enough for the eyepiece lens to fit into the **tube** firmly.

It might also be necessary to enlarge the cut on the other side so that **the** lens will fit in such a way that **the exact centre** of lens is in the centre of the tube.

3. Make sure that the lens is in the centre of **the** tube and also that it is **perpendicular** to the longitudinal axis of the tube.

4. Insert the lens and cover the cuts with insulation tape.

**5. Fitting the objective :** Fit the cork into the bamboo tube. Cut-off any part of the cork which extends more than 5 millimeters out of the tube,

# COMPOUND MICROSCOPE PARTS

FIG. 8

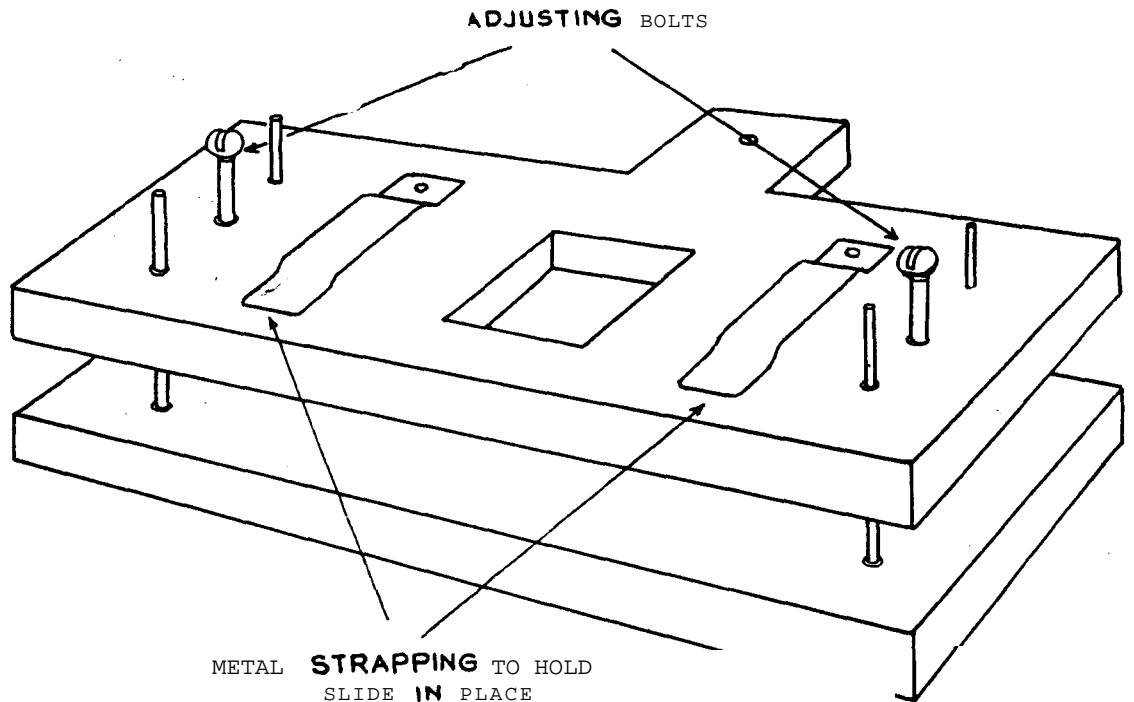
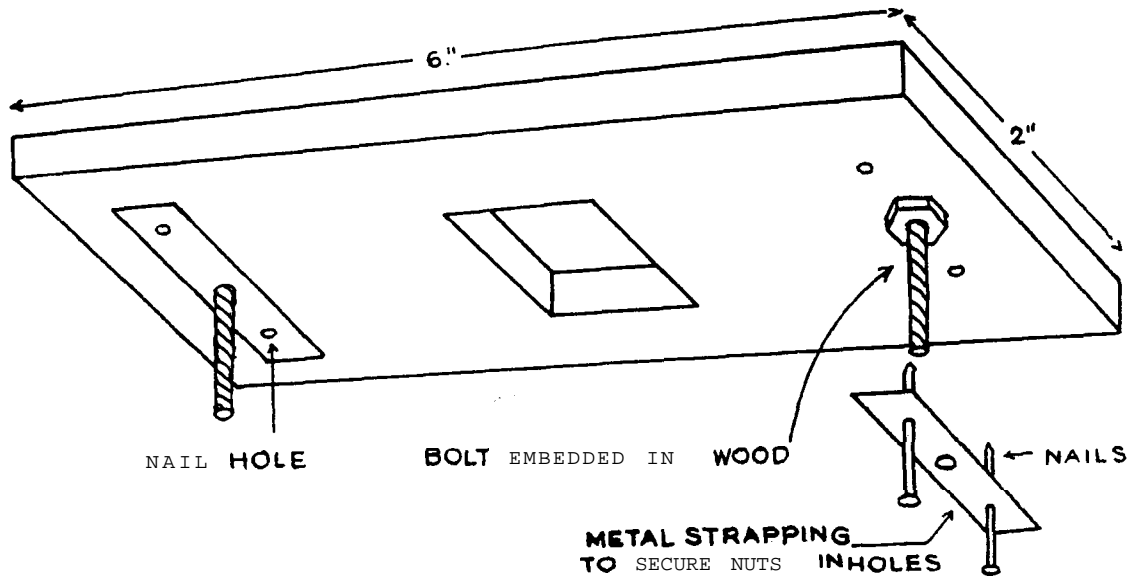

6. With a cork borer of diameter slightly less than the diameter of the pen-torch light bore a hole in the exact centre of the cork.
7. Force the lens into the hole so that it remains there firmly. Make sure that the eyepiece and the objective lenses are parallel.
8. Insert the cork into the bamboo so that the centres of the two lenses are exactly the distance "D" apart and that the cork fills the entire hole in the tube.
9. Cut and sand the 6"  $\times$  2½"  $\times$  7" wood piece.
10. With a saw, cut the lines indicated in Figure 5.
11. With a chisel, cut out the unnecessary wood as indicated.
12. Cut the base piece of the stage as indicated in Figure 6.
13. Using a nail as a drill bit, drill two holes in the handle of the base piece to attach it to the barrel holder.
14. Chisel a 3/5" square hole in the base piece so that the centre of that hole will be directly below the centre of the lenses.
15. *Moving Stage:* Chisel a 3/4" square hole in the centre of this piece checking to see that its centre is directly below centre of the lenses.
16. Using a 1½" thin wire nail as a drill bit, drill four holes in the moving stage in the positions indicated in Figure 7.
17. With a 3/16" drill bit, drill two holes in this piece in the positions indicated in the figure.
18. On the under side of moving stage, widen the 3/16" hole until the nut fits into it. Drill a hole through the 1" pieces of strapping and nail over the net. Make sure that the bolt turns freely in the nut (see Figure 8).
19. Bend the 9" pieces of strapping as shown in Figure 9 and nail them to the stage as indicated. These pieces are to hold the slide in place.
20. Using the four nail holes as guides, nail the four 1½" nails to the base piece. Cut-off the hands of these nails. See that the stage moves up and down freely as you turn the adjusting bolts.
21. *Stand:* Cut, square and smooth all the wooden pieces in 14, 15 and 16.
22. Drill a 1/4" hole through the two uprights and the barrel holder so that the 1/4" bolt will Et-through all three and barrel holder will turn on that axis (see Figure 12).
23. Nail the two uprights to the stand as indicated in Figure 11.
24. Assemble the mirror mount as shown in Figure 12.
25. Find the proper place for the mirror by temporarily mounting the barrel holder in the uprights and finding where the lens is. Place the mirror mount so that the centre of the mirror is directly beneath the centre of the objective lens.
26. Paint or varnish the entire apparatus.
27. Attach the mirror to the mirror mount with glue.
28. *Final Adjustments :* Nail the stage to the barrel holder as shown in Fig. 13.
29. Attach the barrel to the holder with insulation peat.

# COMPOUND MICROSCOPE PARTS

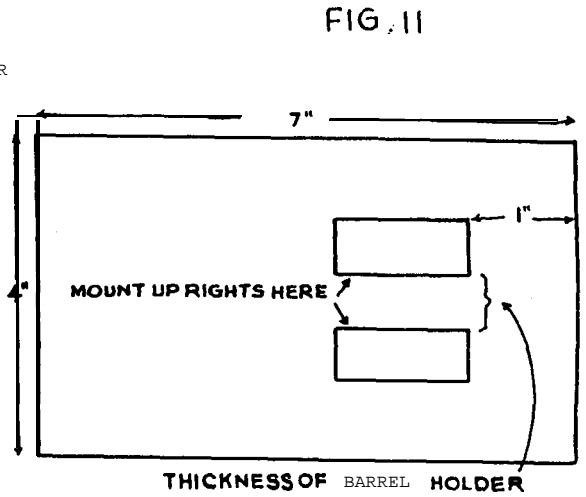
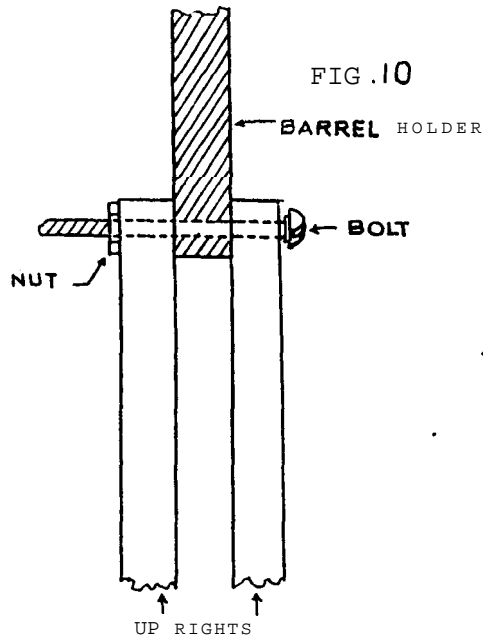

FIG. 12

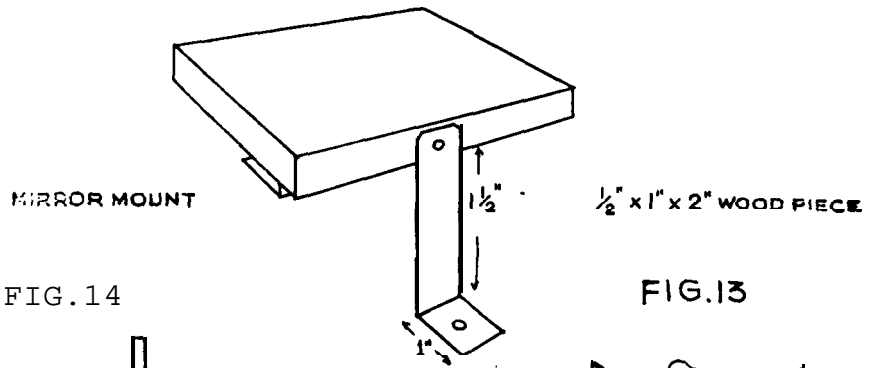

FIG. 14

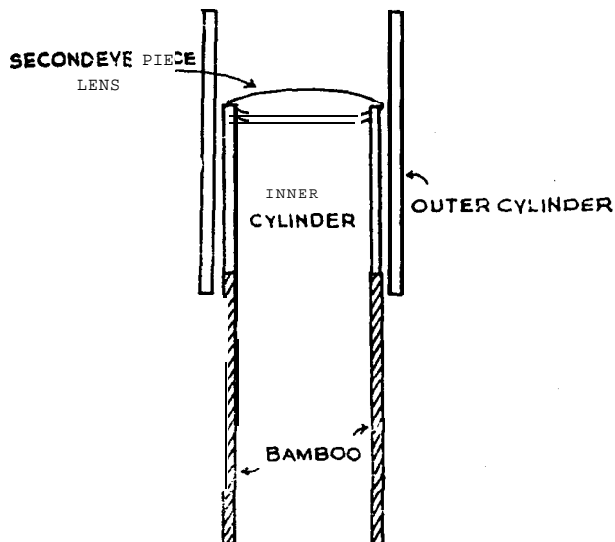
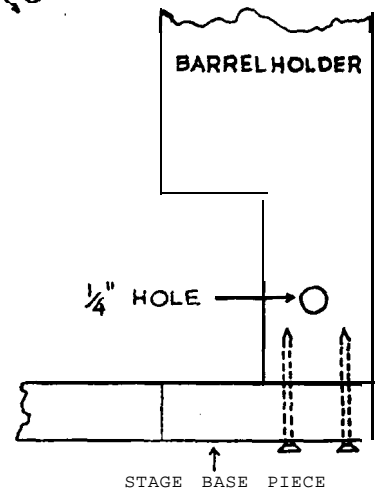

FIG. 13



30. **Focusing:** With a slide held securely on the stage, focus the image by adjusting the moving stage. Place your eye on the open top of the bamboo and adjust until you see a clear image of the slide. Move your eye back until the image fills the entire field and make more minor adjustments.

31. **The second eyepiece lens :** Take the other watchmaker's lens and place on top of the open bamboo tube. If the image **fills** the field, attach. However, if it does not fill the field, move the lens up and down until you find the place where the image is the largest.

32. The most important factor in the clearness of the image is the distance between the objective and the first eye-

piece lens. If the image is not perfectly clear, this distance may need final adjustment.

33. Roll some heavy cardboard into a cylinder the length of which should be the distance from the top of the bamboo to the lens at the correct position and whose diameter should be just less than the outside diameter of the bamboo tube. Place the lens on top of this cylinder.

34. Roll another cylinder which will fit snugly over the bamboo tube and the first cylinder. This cylinder will hold the smaller cylinder in place and also hold the lens on top of the small cylinder (see Figure 14).

### Uses in practicals and demonstrations

1. For use in examining micro-organisms.
2. To demonstrate the construction of a compound microscope.
3. To study the optics of the microscope.

### Questions for further study

1. What are the conditions governing the length of the microscope tube?
2. What should be done in order to reduce the length of the tube?
3. What kind of lenses must we use in order to achieve greater magnification?
4. Why is there a distortion in the image?
5. What is spherical aberration? Can you observe it? What is chromatic aberration? Can you observe it? **How** can you decrease these distortions?
6. Where do you think the image forms?
7. What would *you* suggest to get a brighter image?
8. Why should you keep your eye a bit higher than the top of the lens?

# SCALPEL

MAKE A, BLADE FOR  
THE SCALPEL BY  
BREAKING IT AS SHOWN

RAZOR BLADE

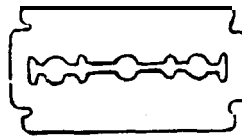

A

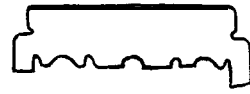

B



BAMBOO



C

SHAVE



THE EDGE



SLIT FOR THE BLADE



BLADE



SECURE WITH A THREAD OR THIN WIRE



BLADE MADE FROM HEAVY STRAPPING

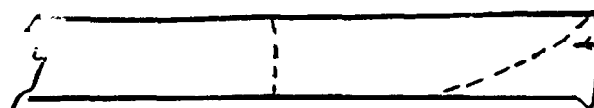

CUT AND SHARPEN

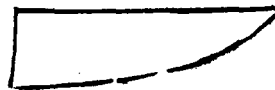

# DISSECTING KIT

## Materials required **construction**

1. Bamboo pieces.
2. One razor blade.
3. Strong thread.
4. Sewing needle.
5. Metal strapping.
6. Heavy wire.
7. 3 litre tin.
8. Candle wax.
9. Hinges.
10. Two  $1\frac{1}{2}$ " x 5" x 7" wood pieces.
11. Four  $1\frac{1}{2}$ " x 1" x 5" wood pieces.
12. Four  $1\frac{1}{2}$ " x 1" x 6" wood pieces.

## Procedure for construction

1. **Scalpel:** Take a bamboo piece 5" long and  $\frac{5}{16}$ " in diameter and carefully split one end about  $\frac{3}{8}$ ".
2. Shave the bamboo to form a slope on either side of the slit.
3. Break a discarded razor blade in half lengthwise and insert this piece into the slit. Secure the blade in position by wrapping strong thread of soft iron wire around the bamboo.
4. Note Strapping could also be useful in making a blade, A piece of thick strapping  $2\frac{1}{2}$ " in length can be **shaped** and sharpened to form the scalpel **blade**.
5. **Forceps:** Select a piece of dry bamboo about 5" long and  $\frac{1}{4}$ " thick.
6. Shave one side of the bamboo to a thickness of about  $\frac{1}{8}$ " leaving  $\frac{3}{4}$ " off at one end unshaved. See diagram.
7. Shape the shaved portion to look like one half of a pair of forceps.
8. Shave the  $\frac{3}{4}$ " end of the bamboo, making it slope towards the unpointed end.
9. Prepare another piece just like the first.

# FORCEPS

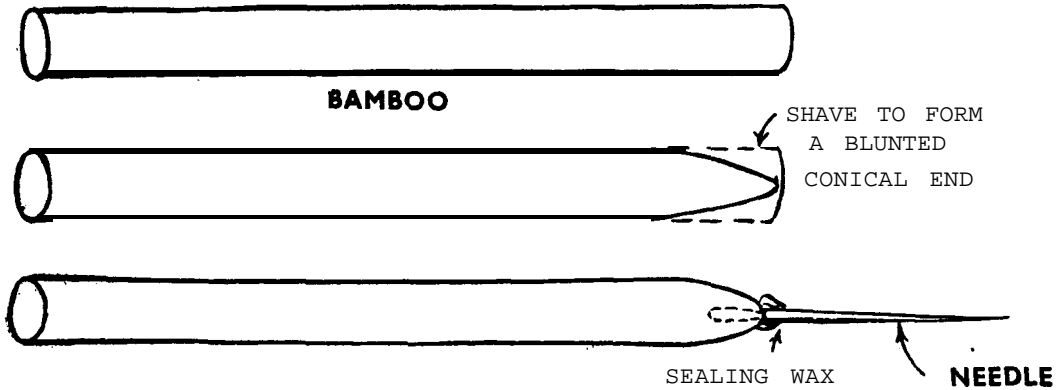
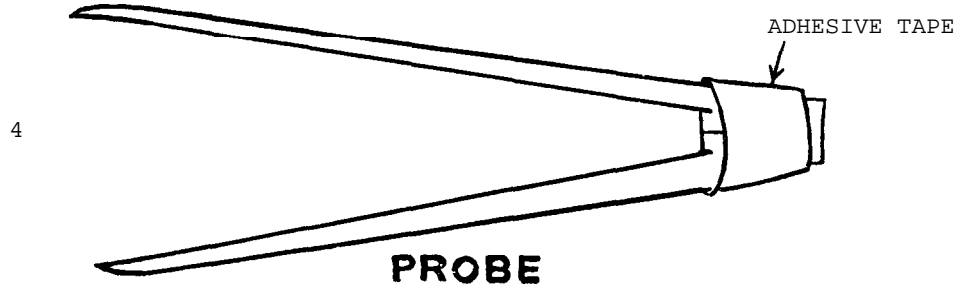
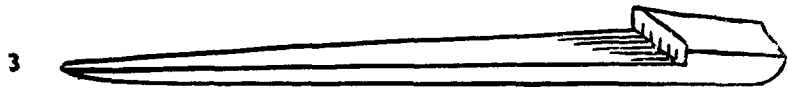
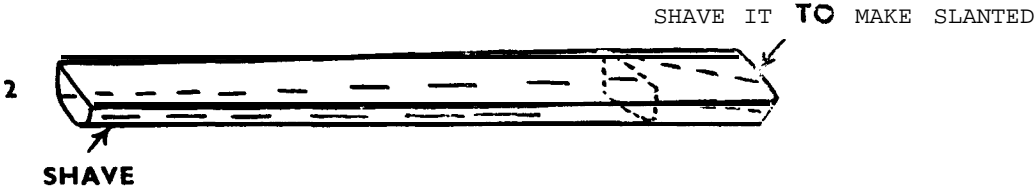
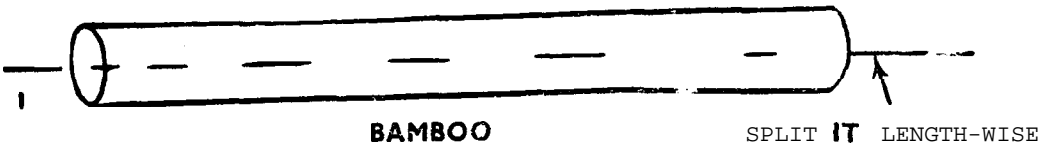



# SCISSORS



STRAPPING  
(TWO PIECES ARE REQUIRED)

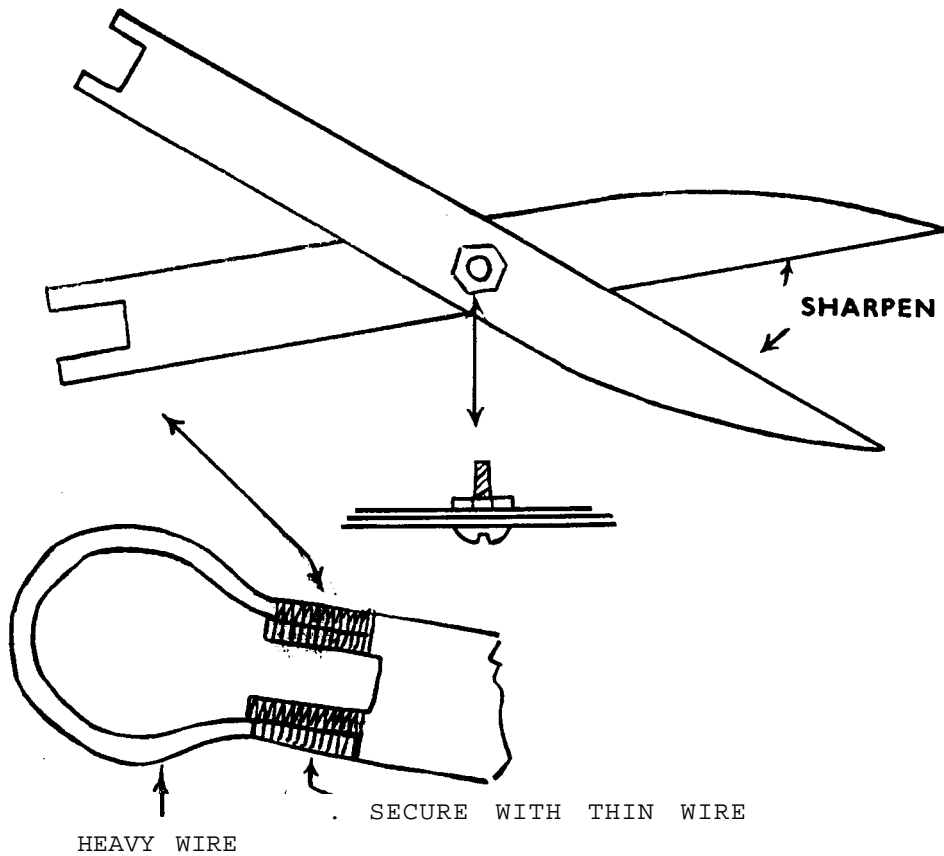
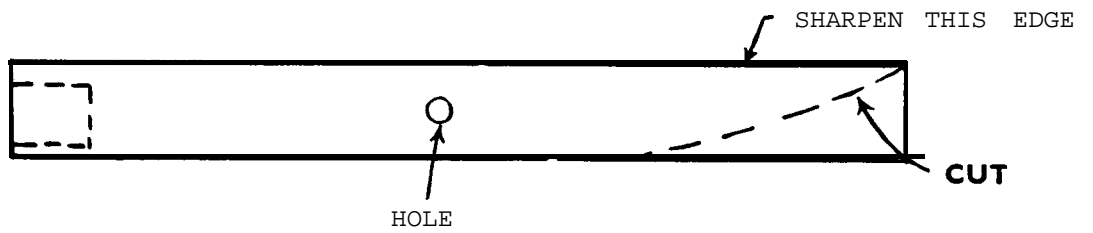

# THE BOX

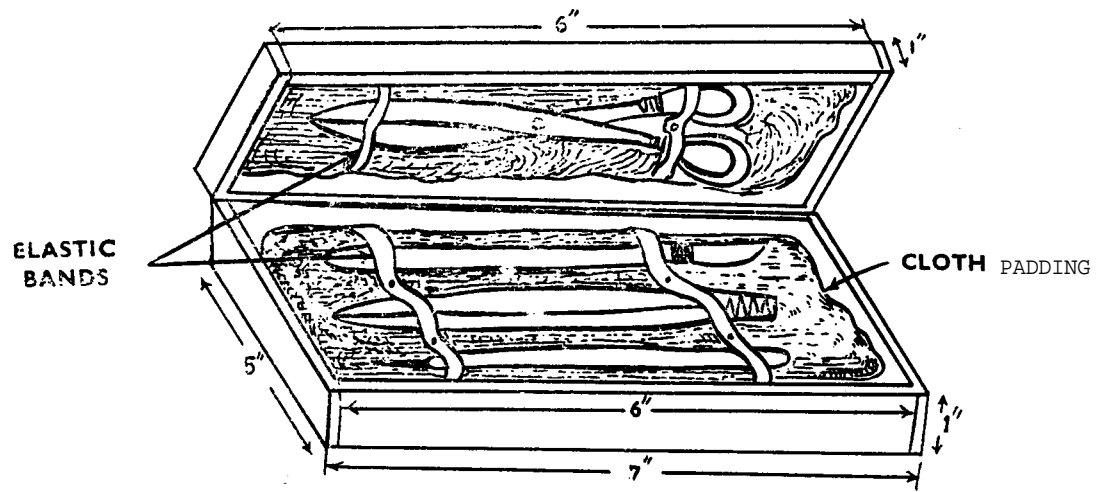

## DISSECTING PAN

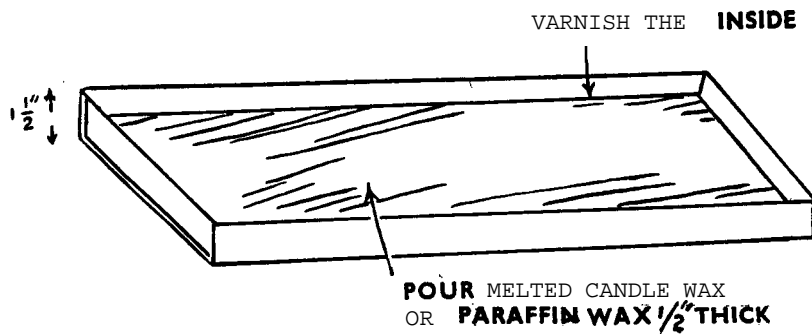
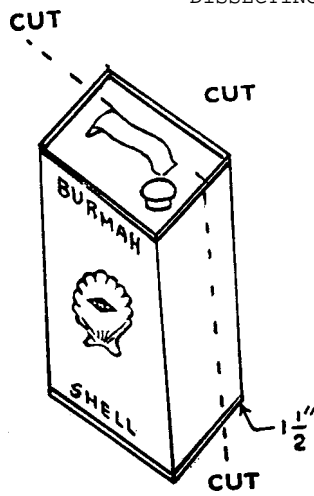

10. Put the thick ends together and tie them with strong thread. Wrap some adhesive plaster around the thick ends.
- 11. Dissecting Needle :** Take a bamboo piece about 5" long and 3/8" in diameter.
12. Shave one end to form a conical part. The end of the conical part is to be blunt.
13. Make a hole about 1/4" deep in the blunt end.
14. Take a needle and with the help of pliers force the blunt end of the needle into the hole. Secure it in the hole with sealing wax.
- 15. Scissors:** Take two pieces of strap-ping 1/2" wide and 6" long.
16. Make holes at the geometrical centre of the two pieces.
17. Shape them as shown in the diagram.
- 18.** Bolt the two pieces together.
19. Bend 2 1/2" to 3" of heavy wire to the shape shown in the diagram. Secure it to the ends of the scissors with thread and adhesive tape.
- 20. Dissecting Pan:** Cut the 3 litre tin as shown in the diagram to form a tray 1 1/2" deep.
21. Melt some candle wax and pour enough into the tray to form a layer 1/2" deep.
22. Varnish the exposed metal.
- 23. Box Container for Kit:** Assemble the wood pieces as shown in the diagram.
24. Varnish them.
- 25.** Attach the top to the box with hinges.
26. Put cloth padding inside.
27. Fix elastic bands inside the bottom and top parts as shown in the diagram.
28. Adjust to fit your dissecting tools.

#### Uses in **practicals** and demonstrations

This piece of apparatus is an emergency measure for biology classes where dissection by the entire class is advisable but the materials are not available.

With this kit the student can be expected to have a kit with which he can perform dissections in the classroom, at home or in the science club.

# RESPIROMETER

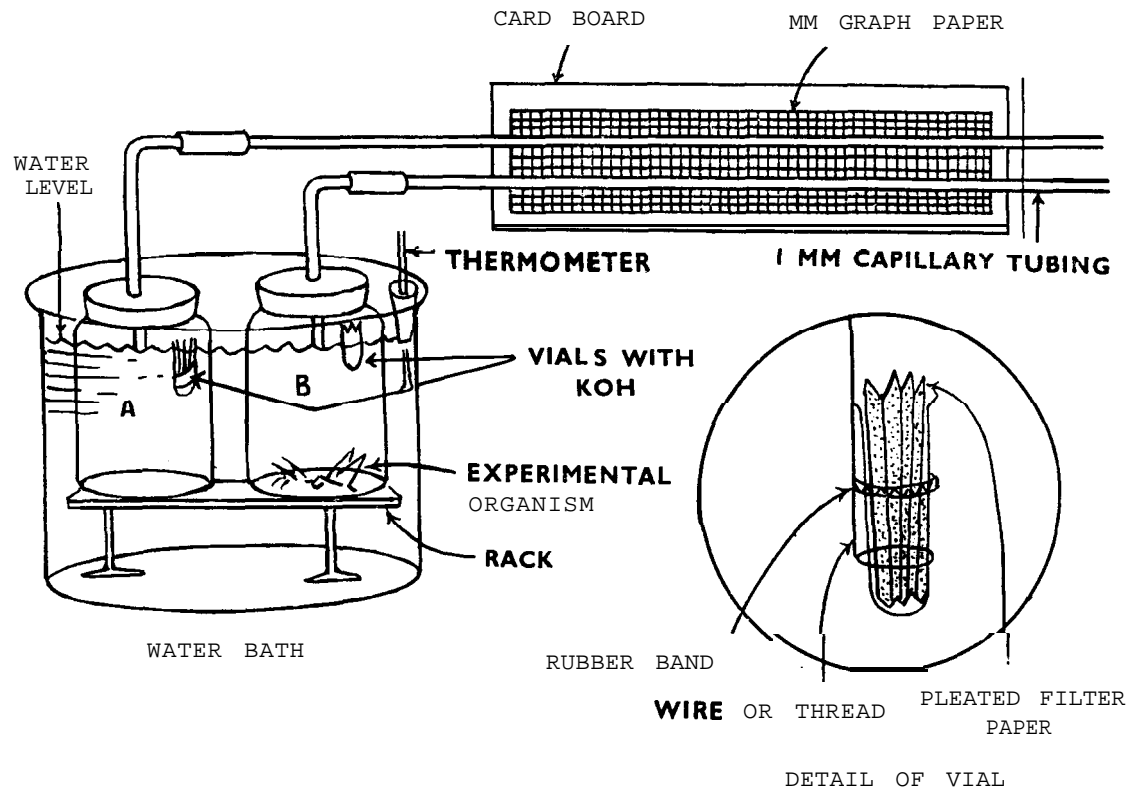

# RESPIROMETER

## Materials required for construction

1. Any large tin or glass container.
2. Two wide mouth bottles.
3. Two one-holed rubber stoppers.
4. 12" of 5 mm glass tubing.
5. Two 3" pieces of capillary tubing
6. Rubber tubing.
7. 24 gaugron wire.
8. Rubber bands.
9. Medicine dropper.
10. Graph paper.
11. 6" x 36" cardboard piece.
12. 15% solution of KOH or 40% solution of NaOH.
13. Filter paper.
14. Two small test tubes or injection bottles.
15. One small wooden stand
16. One thermometer,
17. One cork.

## Procedure for construction

1. Cut the 5 mm glass tubing into two 6" pieces and bend each 2" from one end to form a 90° angle.
2. Connect the 2" end of each glass tube to the capillary tubes by using a small piece of rubber tubing.
3. Fit the long ends of the 5 mm tubing to each of the one-holed stoppers.
4. Pleat two pieces of filter paper and dip them into the **KOH** solution. Put them into the small test tubes or the injection bottles. See diagram.
5. From the iron wire make a loop which fits the necks of the test tubes. Bend the rest of the wire upwards and into a hook which you will attach to the lip of the wide mouth bottles. Wrap a rubber band around the bottle to secure the wire to the side of the test tube. The test tubes should now, be suspended inside the wide mouth bottles.
6. Close the wide mouth bottles with the rubber stoppers mentioned in step 3 above.
7. Attach the graph paper to the cardboard piece and then fix this piece behind the capillary tubes. See diagram.
8. Place the stand in the large container and put the two wide mouth bottles on it. Secure in place with rubber bands.
9. Pour water into the large container until it comes to the necks of the bottles.
10. Fix a thermometer in a cork and float it in the water.
11. Put a small cockroach or any other insect, whose respiration you wish to measure, in one of the wide mouth bottles.
12. Introduce a drop of colored water into the capillary tubes and the apparatus is ready for **your** experiment.

## Uses in practicals and demonstrations

This piece will be found helpful in measuring the rate of respiration in living organisms, either in your science club projects or in your classroom demonstrations

## STEPS IN BUILDING SCIENCE APPARATUS

1. Read the plans (or draw up a set of plans). Take special note of the types and sizes of materials required and modify the plans if necessary to suit your needs. For instance, if certain materials are not available, you may substitute other materials in their place. Most important, thoroughly understand the plans or directions before beginning the construction. It is difficult and often unsatisfactory to correct construction mistakes which result from poorly understood directions.
2. If wood is to be used, select a type that is easy to work with; measure and mark-off the sizes required. Cut the pieces, making sure that they square, and use sandpaper to make them smooth. Such operations as chiseling and boring holes should be done during this step.
3. Fasten the sanded pieces of wood together with nails, screws, bolts or glue as specified in the plans. Proceed to step four before adding any other materials to the apparatus.
4. Apply the first coat of varnish and allow the assembly to dry. ( Refer to the technique headed "How to Varnish." ) After the first coat of varnish has dried, sand lightly with a piece of fine grade sandpaper and apply the second coat of varnish, which

should dry to a glossy finish. Set the piece aside and wait until it is completely dry. If it is handled while the varnish is wet or tacky, the finished surface will be marred.

5. The time required for the varnish to dry need not be wasted. During this time you can make the metal, plastic and glass pieces required for the apparatus. Follow the plans carefully in this regard so that these pieces will fit into place properly.
6. Assemble the apparatus as shown in the plans.
7. Calibrate the scales, if needed. Test the apparatus for precision, and repair the parts that are not working adequately. This step is the most important. The following are some common mistakes which you should recheck:
  - a. Excess friction may be caused by sticky varnish or rust.
  - b. Electric current will not flow through metal terminals which are coated with varnish or rust.
  - c. For a balance arm to operate properly, the fulcrum must be above the centre of gravity of the arm.

## LIST OF MATERIALS THAT ARE USEFUL FOR THE ACTIVITIES SUGGESTED IN THIS BOOK

1. Empty tin cans of various sizes.
2. Medicine bottles with rubber stoppers - like the penicillin injector bottle.
3. Empty injection vials.
4. Steel needles of different sizes.
5. Press buttons.
6. Empty bottles of different sizes.
7. Blown out light bulbs.
8. Blown out fluorescent tubes.
9. Soda bottle lids.
10. Horlicks bottles and any wide mouthed bottles.
11. Bamboo pieces.
12. Blown out pen torch bulbs.
13. Strapping.
14. Card boards from old cutnote books. **empty cardboard** boxes and the like.
15. Heavy wire pieces.
16. Copper wire from old dynamos, motors or transformers.
17. Corks.
18. Old injection syringes.
19. Wood from package boxes.
20. Old torch light cells.
21. Old razor blades.
22. Cigarette packs with cellophane paper and aluminium foil.
23. Metal strapping from deal wood crates.

### List of materials that are easily available

1. Bolt and nuts.
2. Washers.
3. Nails.
4. Glass tumblers.
5. Rubber bands.
6. Paper clips.
7. Adhesive tape.
8. Soda straws.
9. Wooden foot scale.
10. Pitch.
11. Plane mirrors.
12. Polyethylene tubing.
13. Rubber tubing.
14. Metal or plastic funnels.
15. Medicine measures marked in millilitres.
16. Radio aluminium pulleys.
17. **Earthenware** pots.
18. Enamelled basin etc.
19. Pad clips.
20. Cloth pins.
21. Graph paper.
22. Press buttons.
23. Glue.
24. Torch cells.
25. Quick fix.
26. Iron rods.

### List of chemicals **that** are available in the ordinary market or medicine stores

1. Spirit.
2. Silver nitrate.
3. Potassium permanganate.
4. Soda bicarbonate.
5. Potassium carbonate.
6. Sodium carbonate.

- |   |                       |
|---|-----------------------|
| 7. Yeast tablets.                         | 27. Iodine.           |
| 8. Sodium hydroxide.                      | 28. Bleaching powder. |
| 9. Slaked lime.                           | 29. Sealing wax.      |
| 10. Chalk.                                | 30. Candles.          |
| 11. Sulphuric acid dilute - petrol stand. | 31. Cane sugar.       |
| 12. Vaseline.                             | 32. Borax.            |
| 13. Lead metal.                           | 33. Boric acid.       |
| 14. Potassium chloride.                   | <b>34. Sulphur.</b>   |
| <b>15.</b> Potassium nitrate.             | <b>35. Aluminium.</b> |
| 16. Carboic acid (phenol).                | 36. Iron filings.     |
| <b>17.</b> Magnesium sulphate.            | 37. Magnesium ribbon. |
| 18. <b>Dyes.</b>                          | 38. Mercuric oxide.   |
| 19. Glycerine.                            | 39. Lead oxide.       |
| 20. Sodium chloride.                      | 40. Zinc oxide.       |
| 21. Ammonium chloride.                    | 41. Ferrous sulphate. |
| 22. Copper sulphate.                      | 42. Potassium iodide. |
| 23. Alum.                                 | 43. Oxalic acid.      |
| 24. Turpentine.                           | 44. Camphor.          |
| 25. Gasoline.                             | <b>45</b> Napthalene. |
| 26. Sodium thiosulphate.                  | 46. Menthol.          |
|   | 47. Indigo.           |

—:O:—