

---

## CHAPTER 6

# Scaffolds

Construction jobs may require several kinds of scaffolds to permit easy working procedures. Scaffolds may range from individual planks placed on structural members of the building to involved patent scaffolding. Scaffold planks are placed as a decking over—

- Swinging scaffolds.
- Suspended scaffolds.
- Needle-beam scaffolds.
- Double-pole, built-up, independent scaffolds.

Scaffold planks are of various sizes, including 2 inches by 9 inches by 13 feet, 2 inches by 10 inches by 16 feet, and 2 inches by 12 inches by 16 feet. You may need 3-inch-thick scaffold planks for platforms that must hold heavy loads or withstand movements. Planks with holes or splits are not suitable for scaffolding if the diameter of

the hole is more than 1 inch or if the split extends more than 3 inches in from the end. Use 3-inch planks to build the temporary floor used for constructing steel buildings because of the possibility that a heavy steel member might be rested temporarily on the planks. Lay single scaffold planks across beams of upper floors or roofs to form working areas or runways (see *Figure 6-1, page 6-2*). Run each plank from beam to beam, with not more than a few inches of any plank projecting beyond the end of the supporting beam. Overhangs are dangerous because people may step on them and overbalance the scaffold plank. When laying planking continuously, as in a runway, lay the planks so that their ends overlap. You can stagger single plank runs so that each plank is offset with reference to the next plank in the run. It is advisable to use two layers of planking on large working areas to increase the freedom of movement.

### SWINGING SCAFFOLDS

The swinging, single plank, or platform type of scaffold must always be secured to the building or structure to prevent it from moving away and causing someone to fall. When swinging scaffolds are suspended adjacent to each other, planks should never be placed so as to form a bridge between them.

#### SINGLE-PLANK SWINGING SCAFFOLDS

A single scaffold plank may be swung over the edge of a building with two ropes by using a scaffold hitch at each end (see *Figures 6-2, page 6-2, and 2-28, page 2-20*). A tackle may be inserted in place of ropes for lowering and hoisting. This type of swinging scaffold is suitable for one person.

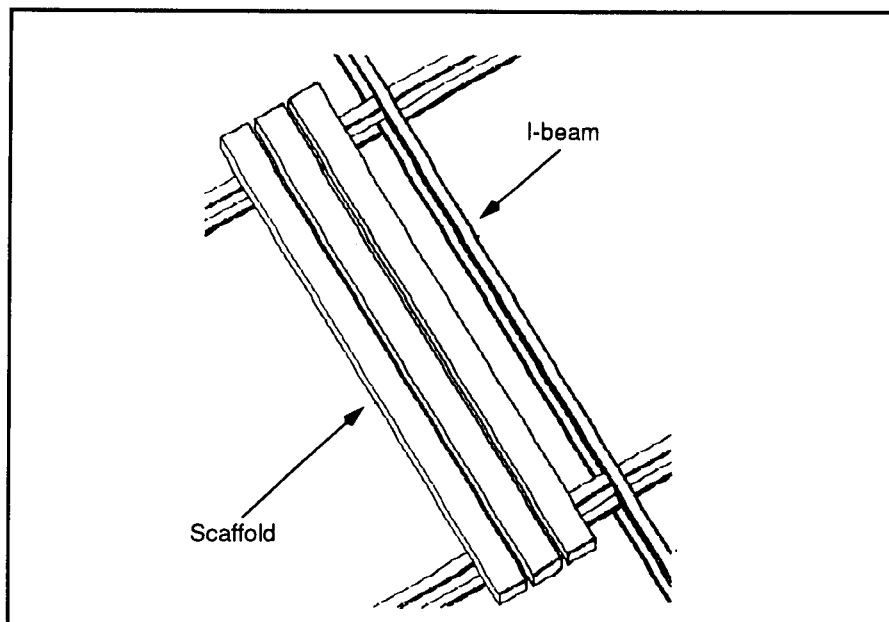

**Figure 6-1. Scaffold planks in place**

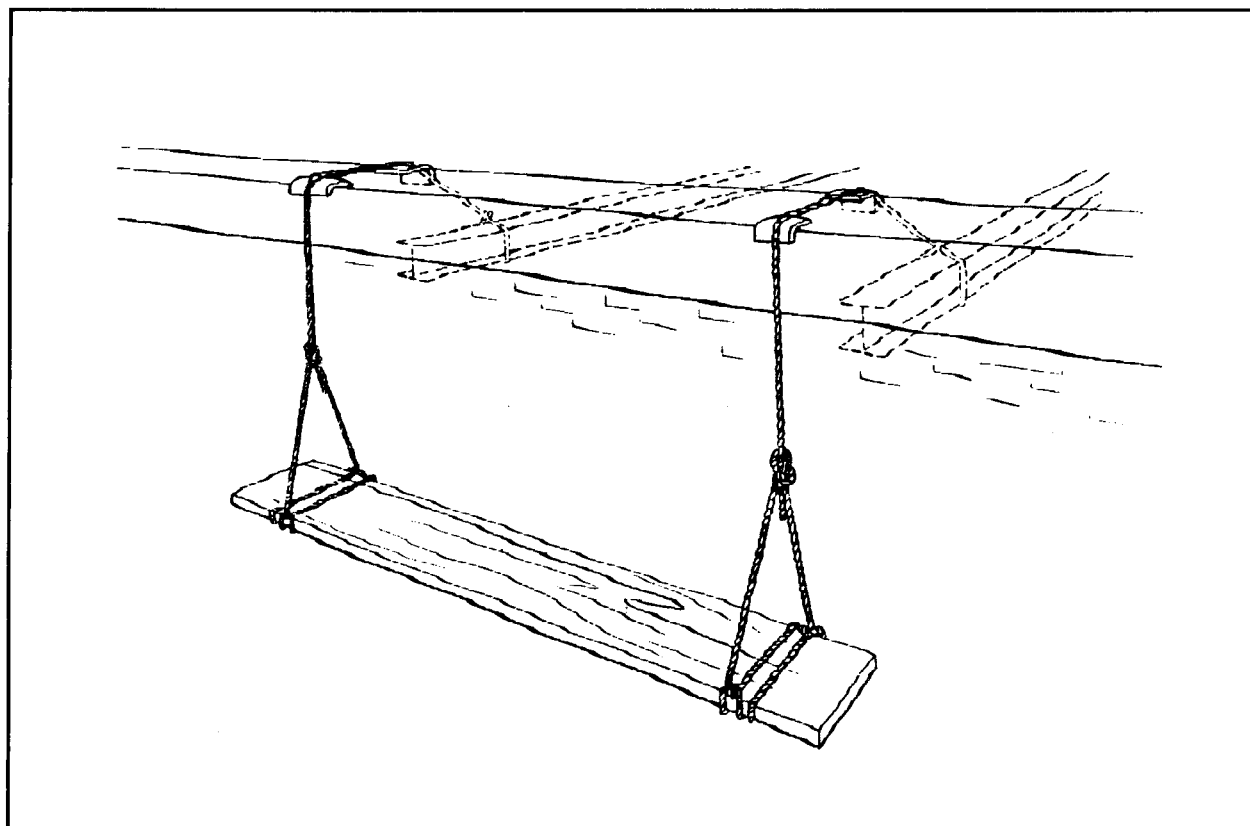

**Figure 6-2. Single-plank swinging scaffold**

### SWINGING PLATFORM SCAFFOLDS

The swinging platform scaffold consists of a frame similar in appearance to a ladder with a decking of wood slats (see *Figure 6-3*). It is supported near each end by a steel stirrup to

which the lower block of a set of manila rope falls is attached. The scaffold is supported by hooks or anchors on the roof of a structure. The fall line of the tackle must be secured to a member of the scaffold when in final position to prevent it from falling.

### SUSPENDED SCAFFOLDS

Suspended scaffolds are heavier than swinging scaffolds and are usually supported on outriggers at the roof. From each outrigger, cables lead to hand winches on the scaffold. This type of scaffold is raised or lowered by operating the hand winches, which must contain a locking device. The scaffold may

be made up in almost any width up to about 6 feet and may be 12 feet long, depending on the size of the putlogs, or longitudinal supports, under the scaffold. A light roof may be included on this type of scaffold to protect people from falling debris.

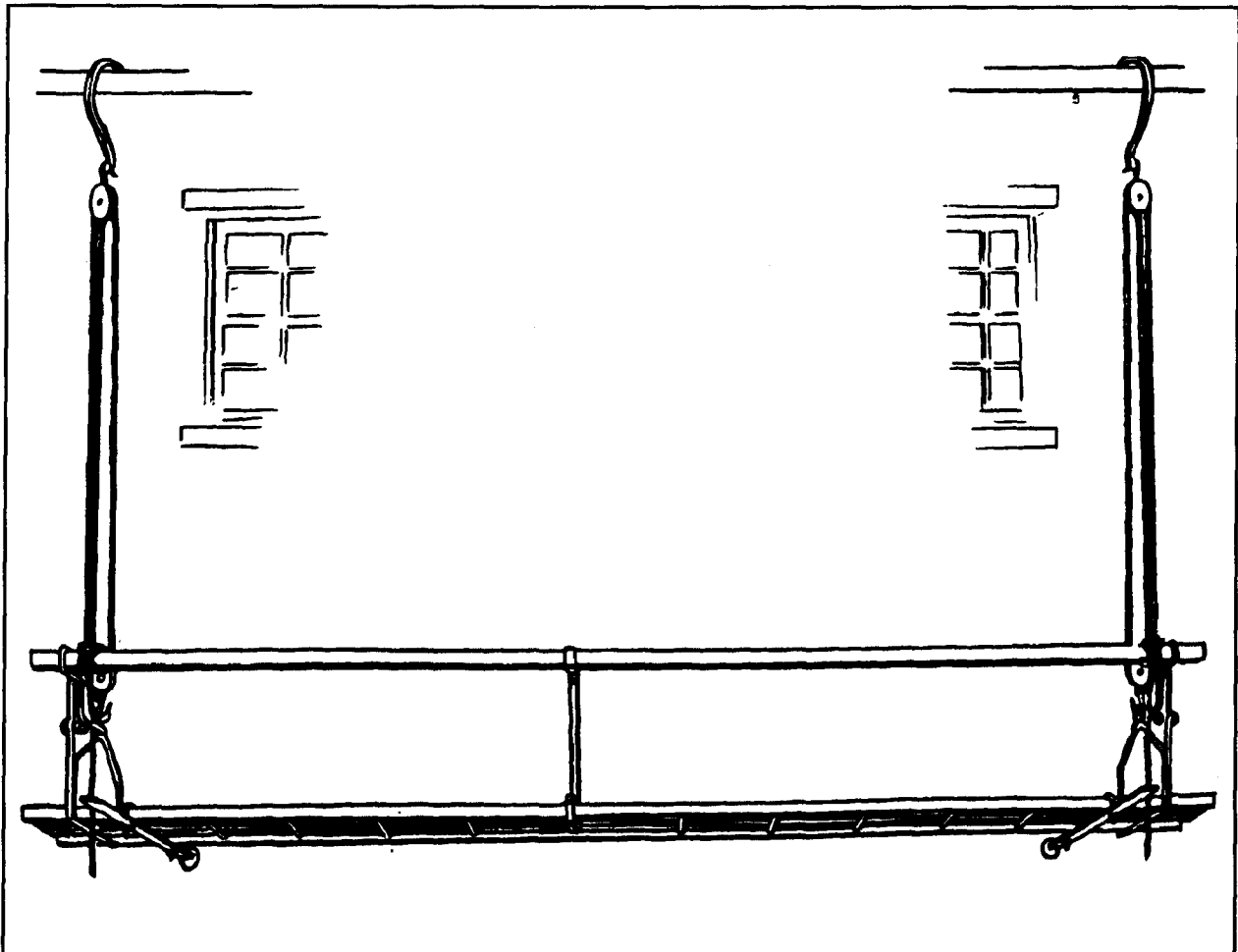

Figure 6-3. Swinging platform scaffold

## NEEDLE-BEAM SCAFFOLDS

This type of scaffold is used only for temporary jobs. No material should be stored on this scaffold. In needle-beam scaffolding, two 4- by 6-inch, or similar size, timbers are suspended by ropes. A decking of 2-inch scaffold plank is placed across the needle beams, which should be placed about 10 feet apart. Needle-beam scaffolding is often used by riveting gangs working on steel structures because of the necessity for frequent changes of location and because of its adaptability to different situations (see

*Figure 6-4*). A scaffold hitch is used in the rope supporting the needle beams to prevent them from rolling or turning over (see *Figure 2-28, page 2-20*). The hanging lines are usually of 1 1/4-inch manila rope. The rope is hitched to the needle beam, carried up over a structural beam or other support, and then down again under the needle beam so the latter has a complete loop of rope under it. The rope is then passed over the support again and fastened around itself by two half hitches.

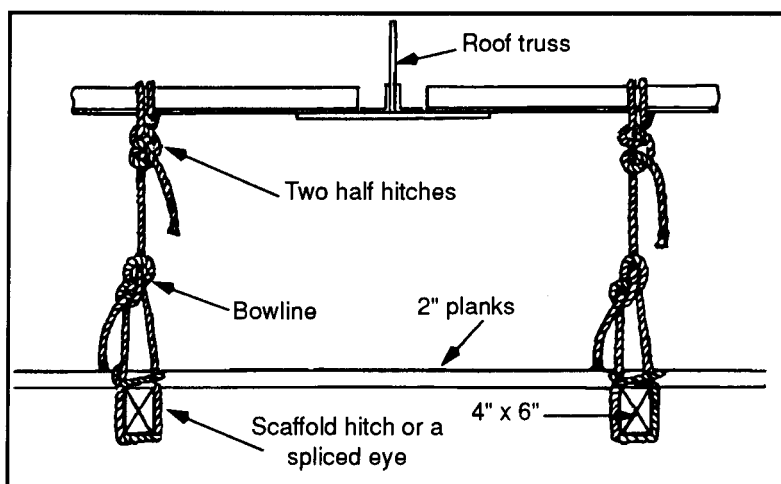

Figure 6-4. Needle-beam scaffold

## DOUBLE-POLE BUILT-UP SCAFFOLDS

The double-pole built-up scaffold (steel or wood), sometimes called the independent scaffold, is completely independent of the main structure. Several types of patent independent scaffolding are available for simple and rapid erection (see *Figure 6-5*). The scaffolding can be built from wood, if necessary. The scaffold uprights are braced with diagonal members, and the working level is covered with a platform of planks. All bracing must form triangles. The base of each column requires adequate footing plates for the bearing area on the ground. Patented steel scaffolding is usually erected

by placing the two uprights on the ground and inserting the diagonal members. The diagonal members have end fittings that permit rapid locking-in position. The first tier is set on steel bases on the ground. A second tier is placed in the same manner on the first tier, with the bottom of each upright locked to the top of the lower tier. A third and fourth upright can be placed on the ground level and locked to the first set with diagonal bracing. The scaffolding can be built as high as desired, but high scaffolding should be tied in to the main structure.

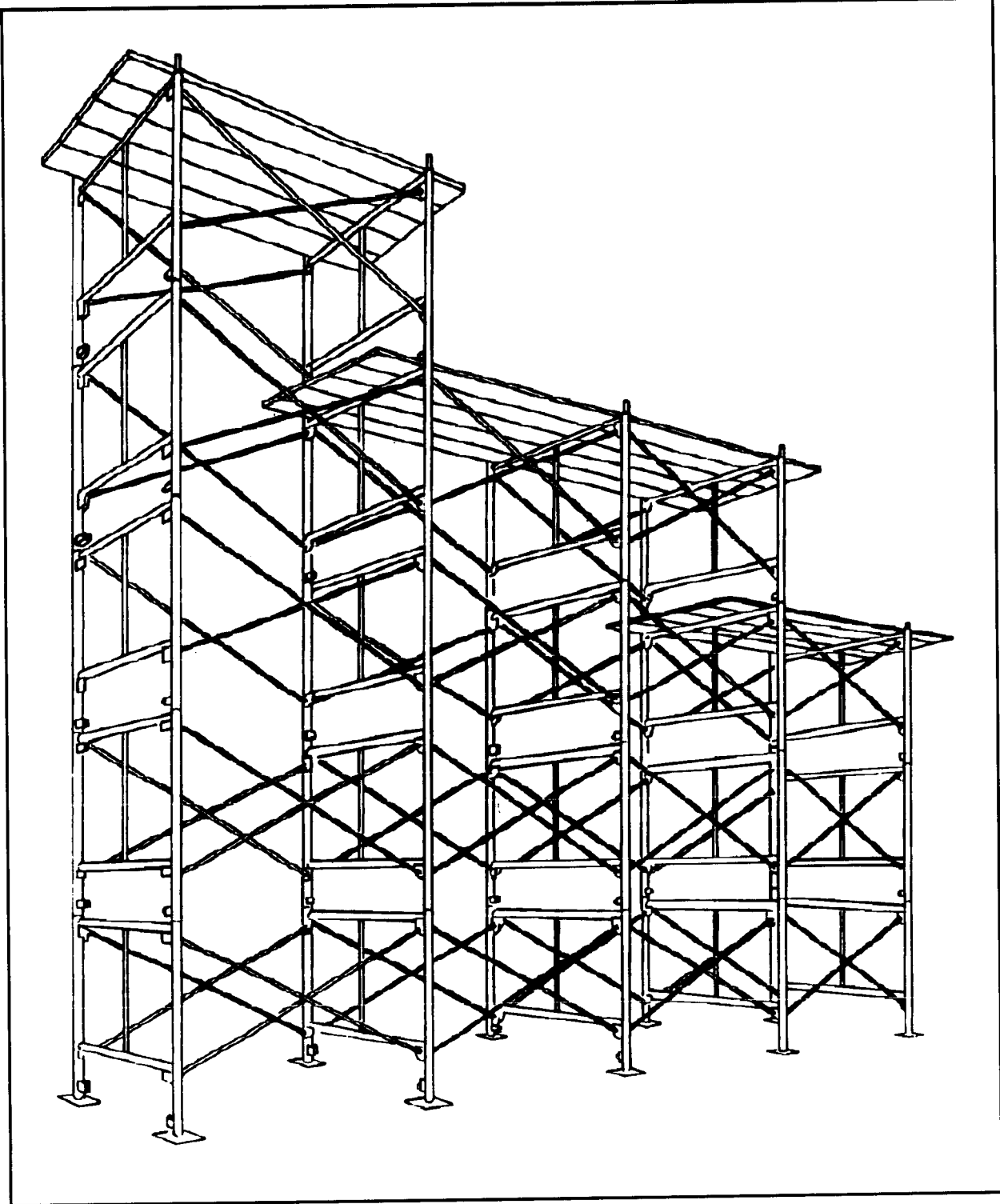

Figure 6-5. Independent scaffolding

## BOATSWAIN'S CHAIRS

Boatswain's chairs can be made several ways, but they usually consist of a sling for supporting one person.

### ROPE CHAIR

You can make a rope boatswain's chair by using a double bowline and a rolling hitch (see *Figure 6-6*). One person can operate the rope seat to lower himself by releasing the grip of the rolling hitch. A slight twist with the hand on the hitch permits the suspension line to slip through it, but when the hand pressure on the hitch is released, the hitch will hold firmly.

### ROPE CHAIR WITH SEAT

If the rope boatswain's chair must be used to support a person at work for some time, the rope may cause considerable discomfort. A

notched board inserted through the two leg loops will provide a comfortable seat (see *Figure 6-7*). The loop formed as the running end to make the double bowline will still provide a back support, and the rolling hitch can still be used to lower the boatswain's chair.

### ROPE CHAIR WITH TACKLE

The boatswain's chair is supported by a four part rope tackle (two double blocks [see *Figure 6-8*]). One person can raise or lower himself or can be assisted by a person on the ground. When working alone, the fall line is attached to the lines between the seat and the traveling block with a rolling hitch. As a safety precaution, a figure-eight knot should be tied after the rolling hitch to prevent accidental untying.

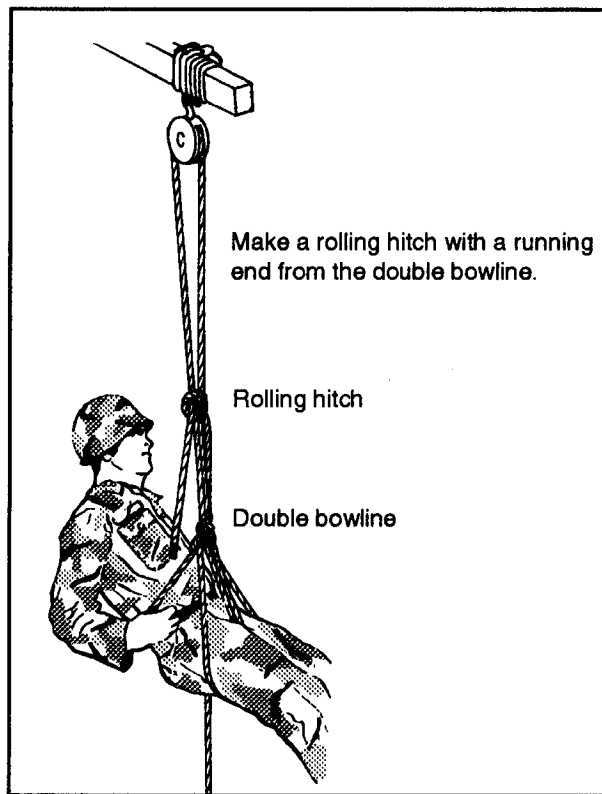

Figure 6-6. Boatswain's chair

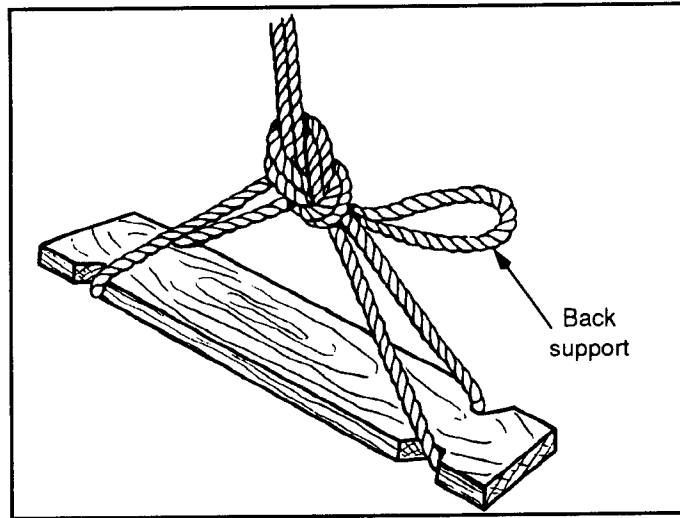

Figure 6-7. Boatswain's chair with seat

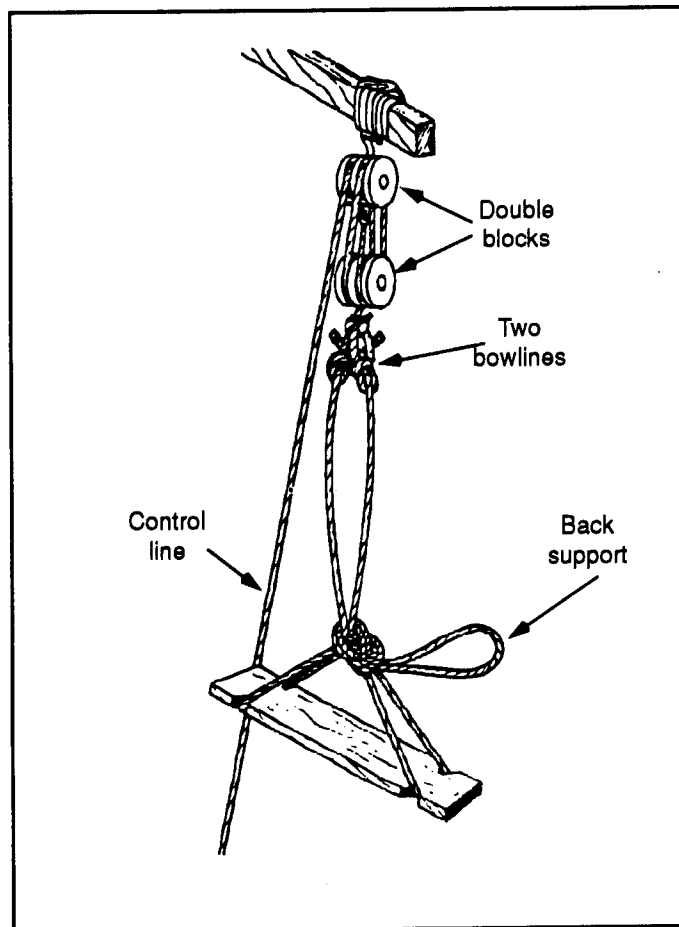

Figure 6-8. Boatswain's chair with tackle