

A Simple Five Component Crystal Detector Radio Receiver Set

OddMix.com - Crystal Radio Note - CRN0703 - Karl Nagy

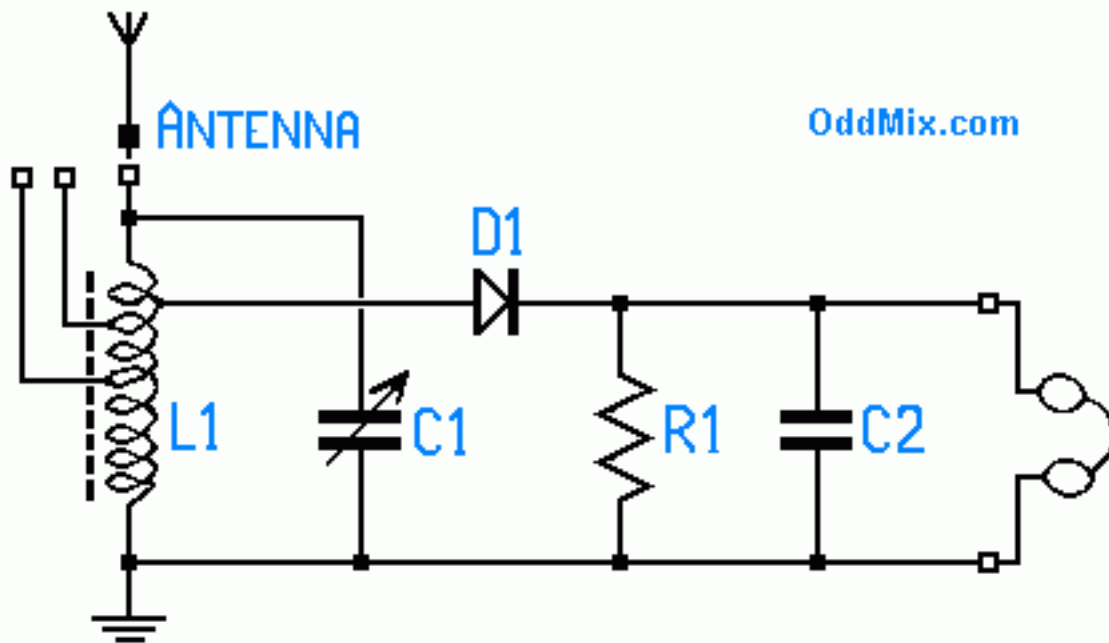

Figure 1. Simple crystal detector radio.

Figure 1 shows a basic crystal detector radio set. Beginners because of its inherent simplicity and ease of construction construct this radio most often. This radio has only five components as either R1 or C2 is not used. In spite of its simplicity it performs well if a high-strung long wire, well-insulated antenna is available, or if strong stations are nearby. A short-wave version works great almost everywhere when wave propagation is good.

Parts list for simple five component crystal detector radio:

- L1 - Antenna coil - 75 turns 180 uH (micro Henry)
- C1 - Rotary Capacitor - 500 pF (pico Farad)
- D1 - [Diode](#) - Germanium, point contact or Crystal Detector
- R1 - Load [resistor](#) - 200 K, used with crystal phones only
- C2 - [Filter Capacitor](#) - 1 nF, used with magnetic phones only



Picture 1.

Coil L1

Coil L1 on **Picture 1** is hand wound in cross or universal style to reduce coil capacitance. It is wound on a 1/4-inch diameter coil form, outfitted with a good (low loss) RF ferrite tuning screw. The antenna coil L1 is 75 turns preferably with 10x0.05 MM Litz wire, with taps at 15, 30 and 45 turns. These taps are useful for improved impedance matching. Coil inductance need to be around **180 uH** if a **500-pF capacitor** is used.

With a capacitor twice larger the coil inductance can be half or 100 uH.

Litz wire is a special insulated multi strand RF magnet wire, in this best case it has 10 strands, each 0.05-millimeter diameter. The more conductors a Litz wire has the merrier. It gets progressively harder to remove the enamel from all the tiny strands for soldering. There are several commercial preparations available for just such an occasion, they work well if not exactly fast. Litz wire with low temperature insulation can be tinned directly, as the enamel melts off during soldering.

Since multi strand wire increases the wire's surface area, it helps to reduce the coils impedance and to overcome the extra increase caused by the skin effects which force RF (Radio Frequency) currents to flow mostly on the conductor's surface. More than one fine wire may be used for the coil making with the same benefits. Any additional single conductor cuts the coil resistance proportionately and the skin effect will diminish too.

Picture 2 shows a good quality, ceramic insulated, sturdy, air dielectric rotary capacitor. It is used for C1, and its value is 500 pF (pico Farad) when closed. D1 is a germanium point contact (cat's whisker) diode, or a crystal detector. With a set of piezoelectric headphones, this radio provides near hi-fi (High Fidelity) sound as much as the AM bandwidth permits such quality reception. As these types of **crystal headphones provide only capacitive loading, the 200 Kohm R1 resistor is required, and the 1 nF (nano Farad) capacitor is unused.** When using magnetic headphones, resistor R1 is not necessary and the 1 nF capacitor C2 is required.



Picture 2. Rotary air capacitor

Carefully done solder connections with rosin core solder, made for electronic soldering, are helpful. Diode soldering is especially critical, as not only excessive heat, but also static electricity can damage point contact diodes. Start up of the completed radio should be easy. Tune in a station, then select the taps on L1 that give the strongest signal. The way to select the tap is by listening to a station and to experiment with different tap points. If a very strong, high-powered local station is in the area, a wave trap circuit may be required.

[Previous Page](#)



Web www.oddmix.com

 Hosted by 1&1

Copyright © 2008 K Nagy - <http://www.OddMix.com> - All Rights Reserved

Page Revised: - 081204 - [Privacy Policy](#) - [Site Map](#) - [Support](#)